

INDUSTRIAL POWER TRANSMISSION BELTS

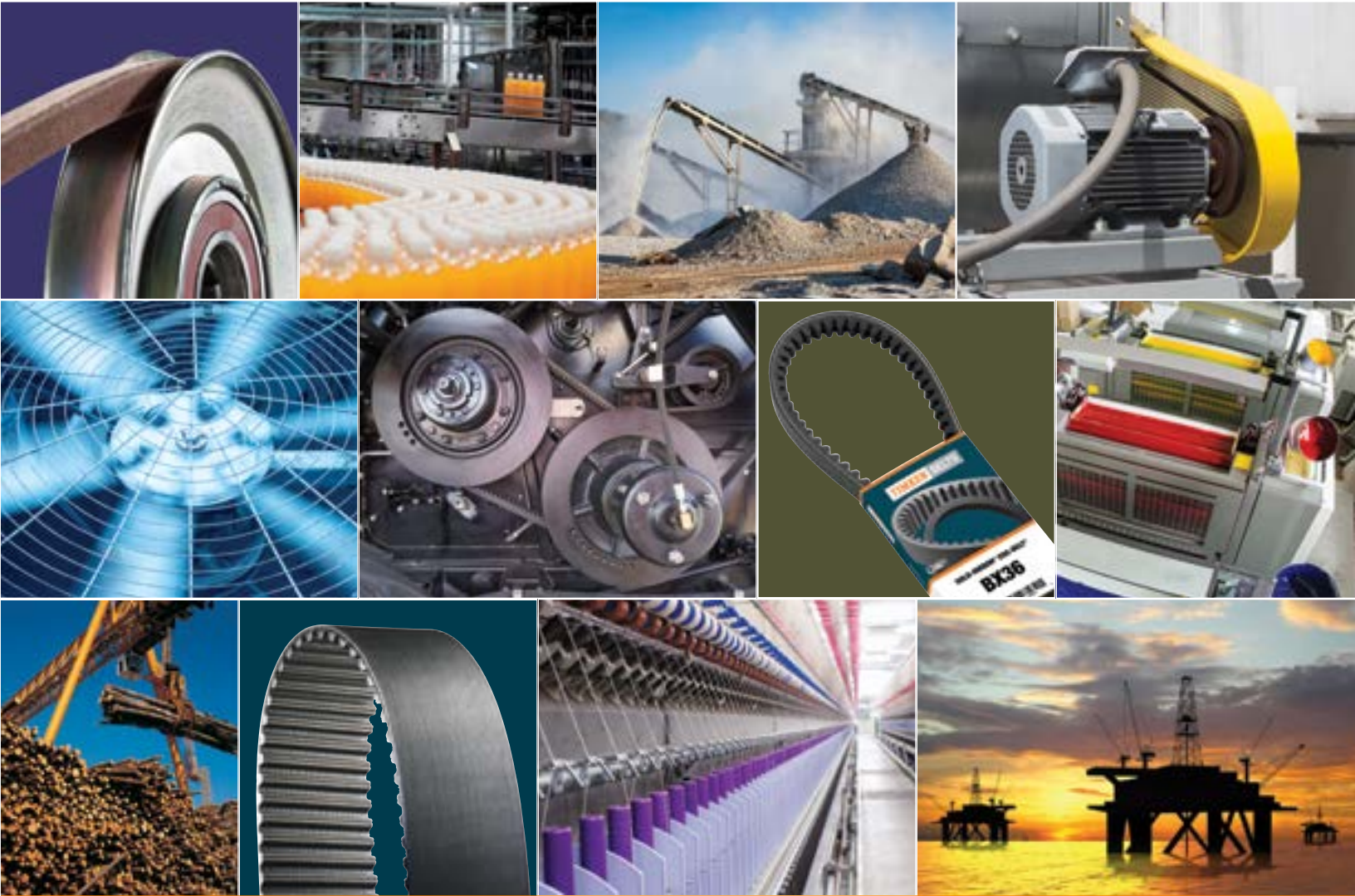

TIMKEN BELTS

Still and **always** Performance Driven. Performance Proven!

Meeting Timken's highest quality standards is no easy task.

Since the acquisition of Carlisle belts in 2015, everything about a Timken® belt has been weighed against the high expectations associated with the Timken brand.

From the science behind each individual component, to the final rounds of rigorous testing – every Timken belt is measured against the highest bar.

- Best-in-Class Engineering and Development
- Advanced Compound and Material Sciences
- Exacting Tolerances for Dimensional Criteria
- Stringent Testing Criteria
- State-of-the-Art Manufacturing
 - Repeatable Process and Control Methods
 - Timken Quality Management Systems
 - Strict Quality Assurance Measureables
 - ISO Certified Manufacturing Facilities

Join us in celebrating our new brand:

TIMKEN BELTS



Table of Contents

Timken Belts Catalog

Table of Contents	1
Introduction	3
Performance Driven. Performance Proven	4
Chek Mate® V-Belt Matching	5
Warnings	6
Trademarks	6
Static Conductive Belts	7
A History of Innovation. A Tradition of Excellence	8
PTplace	9
Catalog Features	9
The Right Belt for the Job®	10



	Cross-Section	Belt Type	Page
Synchronous Belts			12
Introduction to Synchronous Belts			13
Nomenclature			14
Panther® XT Synchronous Belt	8MXT, 14MXT	Extreme Torque Synchronous Belt	15
Panther® Synchronous Belt	8MPT, 14MPT, 20MPT	High Torque Curvilinear Synchronous Belt	21
Panther® Synchronous Sleeve	8MPT, 14MPT, 20MPT	Uncut Full Factory Width Sleeve	32
Synchro-Cog® HT Synchronous Belt	3M, 5M, 8M, 14M	Curvilinear Synchronous Belt	34
Synchro-Cog® HT Synchronous Sleeve	3M, 5M, 8M, 14M	Uncut Full Factory Width Sleeve	60
Dual RPP® Synchronous Belt	D8M, D14M	Double Sided Curvilinear Synchronous Belt	67
Dual RPP® Synchronous Sleeve	D8M, D14M	Uncut Full Factory Width Sleeve	73
Air-Cooled Heat Exchanger (ACHE) Synchronous Belt	14M-F	Z Twist Only Synchronous Belt	75
Air-Cooled Heat Exchanger (ACHE) Synchronous Sleeve	14M-SLF	Uncut Full Factory Width Sleeve	76
Synchro-Cog® Timing Belt	XL, L, H, XH, XXH	Trapezoidal Timing Belt	79
Synchro-Cog® Timing Sleeve	XL, L, H, XH, XXH	Uncut Full Factory Width Sleeve	88
Dual Synchro-Cog® Timing Belt	DXL, DL, DH	Double Sided Trapezoidal Timing Belt	90
Dual Synchro-Cog® Timing Sleeve	DXL, DL, DH	Uncut Full Factory Width Sleeve	95
V-Belts			98
Introduction to V-Belts			99
V-Belt Construction & Advantages			99
V-Belt Installation Check List & Selection Guide			100
Nomenclature			102
Wedge V-Belts			103
Power-Wedge® Cog-Belt®	3VX, 5VX, 8VX	Narrow Raw Edge Cog-Belt	103
Power-Wedge® Cog-Band®	R3VX, R5VX	Banded Version of Power-Wedge Cog-Belt	107
Metric Power-Wedge® Cog-Belt®	XPZ, XPA, XPB, XPC	Metric Narrow Raw Edge Cog-Belt	110
Super Power-Wedge® V-Belt	3V, 5V, 8V	Narrow Wrapped Molded V-Belt	115
Super Power-Wedge® Band	R3V, R5V, R8V	Banded Version of Super Power-Wedge V-Belt	119
Metric Super Power-Wedge® V-Belt	SPB, SPC	Metric Narrow Wrapped Molded V-Belt	123
Aramax® Super Power-Wedge® V-Belt	5VK, 8VK	Narrow V-Belt with Aramid Cord	125
Aramax® Super Power-Wedge® Band	R5VK, R8VK	Narrow Banded Belt with Aramid Cord	128
Metric Aramax® Super Power-Wedge® V-Belt	SPBK, SPCK	Metric Narrow V-Belt with Aramid Cord	132
Chipper Drive Wedge-Band®	R5VL	Laminated Banded Belt for Lumber Industry	133
Classical V-Belts			135
Gold-Ribbon® Cog-Belt®	AX, BX, CX, DX	Classical Raw Edge Cog-Belt	135
Gold-Ribbon® Cog-Band®	RBX, RCX	Banded Version of Gold-Ribbon Cog-Belt	143
Super II® V-Belt	A-R, B-R, C-R	Classical Raw Edge V-Belt	147
Super Blue Ribbon® V-Belt	A, B, C, D, E	Classical Wrapped Molded V-Belt	153
Super Blue Ribbon® Band	RB, RC, RD	Banded Version of Super Blue Ribbon V-Belt	165
Aramax® Xtra Duty V-Belt	3L-K, AK, BK	Extra Duty V-Belt with Aramid Cord	171

Table of Contents

Timken Belts Catalog

	Cross-Section	Belt Type	Page
Double Angle V-Belts			177
Double Angle V-Belt	AA, BB, CC	Double-V (Hexagonal) Belt	177
FHP V-Belts			181
Durapower® II FHP V-Belt	2L-R, 3L-R, 4L-R, 5L-R	Light Duty Fractional Horsepower V-Belt	181
Variable Speed V-Belts			187
Variable Speed Cog-Belt®	V	Variable Speed Belt	187
V-Ribbed Belts			195
Vee-Rib™ Belt	J	V-Ribbed Belt	195
Vee-Rib™ Sleeve	J	Uncut Full Factory Width Sleeve	206
Specialty Belts			207
Cotton Drive® Timing Belt	CCB	One Inch Pitch Timing Belts	209
Dry Can Belt	CC-S	Deep-Groove Double Angle Belt	211
Feather Picker Belt	AAX-FP, BBX-FP	Double Angle Cog-Belt	213
Flour Power™ Roller Mill Belt	8M/PVK, 14M/PVK	Dual Sided Belt	215
Round Belt	7/16, 9/16	Round Belt	217
Super Arc® Belt	B-SA, 9/16-SA	V-Belt and Round Belt	221
Thoro-Twist™ V-Belting	3L, A, B, C	Link Belting for Emergency Replacement	225
Tools			227
Drive Engineer® Web App		Drive design and analysis web app	227
PowerMiser™ Web App		Energy savings calculator web app	228
V-Belt Drives Service Manual	10997	V-Belt Service Manual	228
Tension-Finder® V-Belt Tensioning Tool	108039-A	V-Belt tensioning device	229
Tension-Finder Jr. V-Belt Tensioning Tool	109081	V-Belt tensioning device	229
Spring-Loaded Tensiometer - single stem	102761	Belt tensioning device	230
Spring-Loaded Tensiometer - double stem	105575	Belt tensioning device	230
Spring-Loaded Tensiometer - triple stem	105576	Belt tensioning device	230
Frequency-Finder™ Tensioning Tool	109061	Belt tensioning device	230
Laser-Align™ Tool	109083	Laser alignment device	231
Laser-Align™ Target	109083T	Extra target for Laser-Align	231
Sheave Gauges (Imperial)	102495	Set of templates to check sheave wear	231
Sheave Gauges (Metric)	102496	Set of templates to check sheave wear	231
Belt Finder Tool	93859	Belt measuring device	232
Wallboard Display	93899	Merchandising display system for belts	232
6 inch Hooks	93899-H6	Extra 6 inch hooks for wallboard	232
8 inch Hooks	93899-H8	Extra 8 inch hooks for wallboard	232
12 inch Hooks	93899-H12	Extra 12 inch hooks for wallboard	232
General Information			235
Synchronous Belt Drive Troubleshooting Guide			235
V-Belt Troubleshooting Guide			236
Recommended Sheave Diameters			237
Proper V-Belt Storage Guide			237
Brand Name Interchange			238
Glossary			241

Timken Belts

Introduction

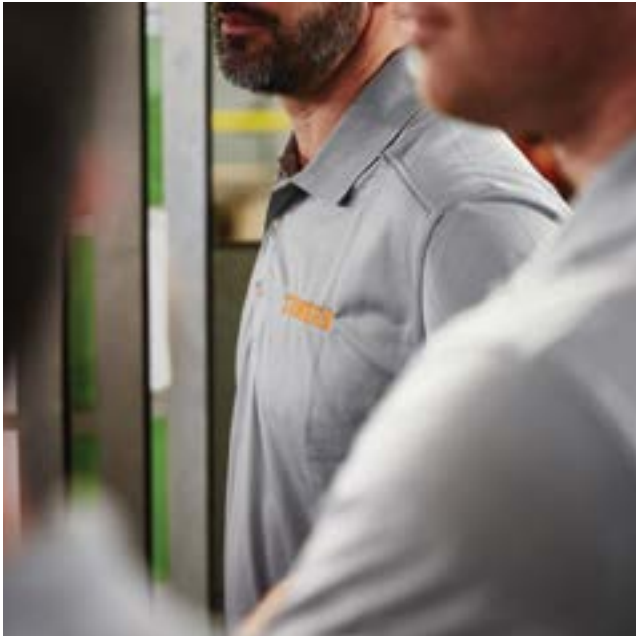

Timken Belts is proud to present this comprehensive product catalog. It provides easy access to the latest product information and technical specifications. We invite you to grow your business with our broad line of premium belts that deliver optimal performance.

Our People

The strength of Timken is its people. For over a century, Timken Belts has adhered to a philosophy of supplying innovative products, unrivaled quality, and superior customer service.

Our Service

Timken® belts are supplied to distributors and original equipment manufacturers who seek the optimum in quality and service. Every belt is backed by extraordinary engineering and technical support, and by our personal, knowledgeable, and attentive customer service team.

On-Time Delivery

Understanding the importance of on-time delivery and fast turnaround, Timken's flexible manufacturing model and short lead times provide responsive, reliable delivery that will meet or exceed your expectations.

Proudly Made in the USA

A comprehensive product line is made in ISO certified manufacturing facilities in the USA by a proud team of engineers, technicians, and craftsmen. The icon below is used throughout this catalog to identify each product line that is manufactured in Timken's Springfield, Missouri or Fort Scott, Kansas belt plants



Timken Belts

Performance Driven. Performance Proven

It's no accident that Timken belts are built to outlast and outperform competitor's belts. That's why recognized original equipment manufacturers turn to Timken to make belts for their products.

Every Timken belt is the result of science, engineering, and years of experience. Timken's innovative product development, specially formulated components, time-tested methods, and state-of-the-art manufacturing techniques set us apart from the competition.

The team of belt experts at the Technical Center in Springfield, Missouri is dedicated to the development and testing of new and existing products to assure that Timken belts provide outstanding performance in a multitude of the toughest, most demanding applications.



Timken Belts

Performance Driven. Performance Proven



Chek Mate® V-Belt Matching

Chek Mate® is a process that manufactures v-belts to meet or exceed the Association for Rubber Products Manufacturers (ARPM) tolerances for a matched set.

Matching numbers are not required on Timken belts which carry the distinctive Chek Mate logo or icon: Super Blue Ribbon®, Super II®, Super Power-Wedge®, Power-Wedge® Cog-Belt® and Gold-Ribbon® Cog-Belt®.



ISO Certification

Timken belt plants and Technical Center are registered as compliant with the International Standard ISO 9001:2015. ISO requirements include:

- Management that is committed, involved, focused and responsive
- People who are organized, responsible, authorized, competent, empowered and knowledgeable
- Processes that are visible, traceable, consistent, repeatable, measurable and documentable
- Documents that are appropriate, relevant, simple, understandable and consistent with processes in use

ISO 9001:2015 certification ensures that organizations take time to understand their key quality processes, that the processes are implemented and followed by everyone in the organization and that the processes are documented and maintained to a degree that can be demonstrated to an outside agency.



Timken is a proud member of:



 **WARNING**

Failure to observe the following warnings could create a risk of death or serious injury.

Static electricity created by a belt in operation can ignite an explosive atmosphere. Special care must be taken in the utilization of belts in or near locations which may contain explosive concentrations of combustible gases or accumulations of dust such as grain, coal, or other combustible materials. Proper dissipation of such potential static electricity discharge must be assured to prevent any such explosion.

 **CAUTION**

Failure to observe the following cautions could create a risk of serious physical injury or property damage.

Proper selection and installation of drive belts are critical tasks. Belts must be properly selected and installed to assure proper performance. Follow all of the equipment manufacturer's safety recommendations, installation procedures and specifications

AIRCRAFT POLICY – SAFETY WARNING

Timken® belts are not designed or intended for aircraft use. Do not use Timken belts or pulleys on aircraft or helicopter engines or propeller, rotor or accessory drives. Do not use Timken belts or pulleys on commercial, private, or ultralight aircraft or helicopters.

The following are registered trademarks of The Timken Company or its affiliates.

- | | |
|-----------------|-----------------------------|
| Aramax® | Super Ag-Drive® |
| Blue Label® | Super Arc® |
| Chek Mate® | Super Blue Ribbon® |
| Cog-Band® | Super II® |
| Cog-Belt® | Synchro-Cog® |
| Cotton Drive® | Super Vee-Band® |
| Drive Engineer® | Tension-Finder® |
| Durapower® | The Right Belt for the Job® |
| Gold-Ribbon® | Timken® |
| Panther® | Ultimax® |
| Power-Wedge® | Ultra-Cord® |
| RPP® | Wedge-Band® |

Contact Us:

Timken belts strives for accuracy in all publications. If you discover an error or need more information, please email belts@timken.com.

About The Timken Company:

The Timken Company is a global industrial leader with more than a century of knowledge and innovation. Timken Belts is part of the company's growing portfolio of engineered bearings and power transmission products. The portfolio is designed to address our customers wide-ranging needs and to fulfill our promise: to keep industry moving forward.

General Information

Static Conductive Belts

Under certain conditions of temperature and humidity, a belt drive may generate static electricity. Belts intended for operation in a potentially dangerous atmosphere should be constructed with a relatively low electrical resistance characteristic. It has become common practice to specify and refer to such belts as “static conductive,” “static dissipating,” or “anti-static.”

The accumulation of electro-static charges can be dangerous for different reasons:

- Generation of radio interference that can cause disturbance to electrical apparatus
- Risk of ignition and explosion in an atmosphere with high levels of combustible materials
- Risk of injury to workers in contact with the components

V-Belt Drives

Timken belts that are static conductive are shown on the chart. Timken belts are branded as “static dissipating” when they meet or exceed testing developed by the Association for Rubber Products Manufacturers (ARPM Bulletin IP3-3). These belts are branded as “static dissipating.”

Synchronous Belt Drives

Timken synchronous belts are not static dissipating.

Timken V-Belts	Cross Section	Static Dissipating
Power-Wedge® Cog-Belt®	3VX, 5VX, 8VX	Yes
Power-Wedge® Cog-Band®	R3VX, R5VX	Yes
Metric Power-Wedge® Cog-Belt®	XPZ, XPA, XPB, XPC	Yes
Super Power-Wedge® V-Belt	3V, 5V, 8V	Yes
Super Power-Wedge® Band	R3V, R5V, R8V	Yes
Metric Super Power-Wedge® V-Belt	SPZ, SPA, SPB, SPC	Yes
Metric Super Power-Wedge® Band	RSPZ, RSPA, RSPB, RSPC	Yes
Aramax® Super Power-Wedge® V-Belt	5VK	No
Aramax® Super Power-Wedge® V-Belt	8VK	Yes
Aramax® Super Power-Wedge® Band	R5VK	No
Aramax® Super Power-Wedge® Band	R8VK	Yes
Aramax® Metric Super Power-Wedge® V-Belt	SPBK, SPCK	Yes
Aramax® Metric Super Power-Wedge® Band	RSPBK, RSPCK	Yes
Chipper Drive Wedge-Band®	R5VL	Special Order Only
Gold-Ribbon® Cog-Belt®	AX, BX, CX, DX	Yes
Gold-Ribbon® Cog-Band®	RBX, RCX	Yes
Gold-Ribbon® Band	RBL, RCL, RDL	Yes
Super II® V-Belt	A-R, B-R, C-R	Yes
Super Blue Ribbon® V-Belt	AP, BP, CP, DP, EP	Yes
Super Blue Ribbon® Band	RBP, RCP, RDP	Yes
Aramax® XDV Belt	3L, AK, BK	No
Double Angle V-Belt	AA, BB, CC	Special Order Only
Durapower® II FHP V-Belt	2L-R, 3L-R, 4L-R, 5L-R	Yes
Variable Speed Cog-Belt®	V	Yes
Vee-Rib Belt	J	Yes
Timken Specialty Belts	Cross Section	Static Dissipating
Dry Can Belt	CC	Special Order Only
Feather Picker Belt	AAX-FP, BBX-FP	No
Flour Power™ Roller Mill Belt	8M/PVK, 14M/PVK	No
Round Belt	7/16, 9/16	Special Order Only
Super Arc® Belt	B-SA, 9/16-SA	No
Thoro-Twist Belting	3L, A, B, C	No
Timken Synchronous Belts	Cross Section	Static Dissipating
All Timken Synchronous Belts	All	No

Timken Belts

A History of Innovation. A Tradition of Excellence

A commitment to customers and to quality has remained steadfast throughout the long and rich history of the Timken Belts business.

Maintaining a tradition of excellence for more than 100 years, Timken belts continue to bring superior performance with unsurpassed reliability to the toughest industrial applications.



- 1905 Dayton Rubber Manufacturing Company (DRMC) founded in Dayton, Ohio
- 1921 DRMC invents first raw edge v-belt
- 1926 Patents raw edge cog-belt
- 1934 Pioneers use of synthetic rubber technology
- 1957 Develops arched cross section v-belts for agricultural applications
- 1959 new belt manufacturing plant opens in Springfield, Missouri
- 1960 DRMC becomes Dayco
- 1967 New technical center opens in Springfield, Missouri
- 1985 Introduces first chloroprene FHP v-belt
- 1986 new belt plant opens in Fort Scott, Kansas
- 1988 Introduces Ultimax, the first high performance CVT belt
- 1994 Introduces RPP® Panther® belts
- 1995 Introduces Super II® classical v-belt line
- 2001 Carlisle Companies Inc. acquires the industrial belt division of Dayco
- 2014 Introduces belts made out of EPDM
- 2015 The Timken Company acquires the Carlisle belts business
- 2015 Introduces Aramax Xtra Duty V-belts for outdoor power equipment
- 2015 One billionth belt sold
- 2015 Introduces Panther XT, a powerful alternative to chain and polyurethane belts
- 2017 Launches Drive Engineer web app to assist in the design and maintenance of belt drives
- 2018 Introduces Ultimax XP extreme performance ATV/UTV drive belt
- 2019 Introduces Super Arc® belt for improved performance on live roller conveyor drives
- 2020 Introduces Feather Picker belt for poultry processing
- 2020 Timken is recognized as one of the world's most ethical companies
- 2021 Timken named one of America's most responsible companies
- 2021 Introduces Flour Power™ roller mill belt

The tradition continues...

Timken Belts

The Right Belt for the Job®

PTplace

Check pricing, availability, place orders and check order status 24 hours a day in the Timken Store on PTplace at www.ptplace.com. If your business is already using the Timken Store, no change is required. Belts are visible for order entry. To gain access as a new user, please contact a belt customer service representative at 877-484-6536. (PTplace is only available in North America to authorized distributors.)

Catalog Features

This catalog is intended as a guide to the standard line of Timken belts. Special belt types and constructions not shown in this catalog may also be available by special order.

Made-To-Order Belts

We manufacture a wide variety of belts for OEM applications. For your unique needs, we can make made-to-order belts. Please contact belt customer service at 877-484-6536 for price, availability, minimum order quantity and lead time.

Standard Belt Sizes

Some non-stock sizes are not shown in the catalog but may be available. Please contact belt Customer Service for availability. Extended lead time and minimum order quantities may apply.

Belt Dimensions

Cross section dimensions and outside lengths are shown for most belts. Every Timken belt is built to exacting specifications that meet or exceed the industry standards of the Association for Rubber Products Manufacturers (ARPM), Mechanical Power Transmission Association (MPTA), International Organization for Standardization (ISO) or German Institute for Standardization (DIN). Dimensions shown in this catalog are for reference only.

Recommended Metal for each Belt Type

For quick reference, each belt section includes the recommended sheave or sprocket.

Belt Weights

Approximate product weight is indicated for each belt and may vary slightly from the actual weight.

Product Improvements

Timken may make changes to standard products to enhance their quality or to improve manufacturing processes. Timken will communicate any changes with Product Information Bulletins.

Troubleshooting Guide

If a belt fails prematurely, it is important to determine the cause of failure so corrective action can be taken. Common symptoms and possible causes are included for synchronous and v-belts.

Brand Interchange

The interchange helps convert other brands to the correct belt.

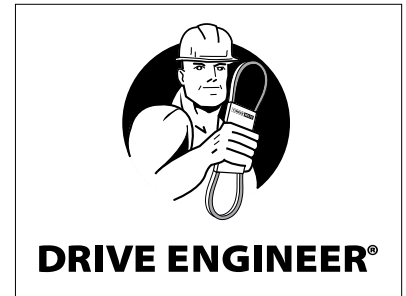

Drive Design and Analysis

Drive Engineer, a web based application for desktop and mobile use, puts drive design and analysis in the palm of your hand. Obtain technical information for v-belt or synchronous drives at: www.driveengineer.com.

Assistance

Some projects may require the expertise of our engineering team. A staff of specialists stands ready to assist with drive design, belt maintenance seminars, and any help needed with choosing the right belt for the application. Your authorized Timken distributor will also be an invaluable resource.

Timken Belts











The Right Belt for the Job®

You can depend on Timken belts for a wide range of applications. We've got you covered with the right belt for most any job. Timken manufactures belts in the USA from 3" to 900" for anything and everything – fans, mixers, pumps, conveyors, machine tools, centrifuges, robotics, and all types of industrial machines. Timken belts are purpose-built and designed for optimal performance on the most demanding applications. Key markets include::

- Agriculture
- Aggregates & Mining
- Energy (Oil & Gas)
- Food & Beverage
- Forest Products Machinery
- HVACR
- Industrial Machinery
- Outdoor Power Equipment
- Powersports



















We collaborate with customers from diversified markets around the globe. The world's leading manufacturers specify Timken belts to keep their equipment running.



Panther® XT Synchronous Belt (8MXT, 14MXT)	
	Alternative to chain or drop-in replacement for super high torque polyurethane belts. Made with carbon cord for enhanced performance and strength. Higher torque capacity than Panther.
Panther® Synchronous Belt (8MPT, 14MPT, 20MPT)	
	High torque synchronous belt with an RPP tooth profile. Designed to improve performance and drive life while reducing maintenance and downtime. Higher torque capacity than Synchro-Cog HT.
Synchro-Cog® HT Synchronous Belt (3M, 5M, 8M, 14M)	
	Curvilinear synchronous belt with HTD® profile. Delivers trouble-free power transmission with a smooth, quiet and efficient drive system.
Dual RPP® Synchronous Belt (D8M, D14M)	
	Double-sided curvilinear synchronous belt with RPP profile. Delivers 100% load capacity on both sides of the belt. Provides greater flexibility and efficiency in your drive design.
Air-Cooled Heat Exchanger Belt (14M-F)	
	ACHE synchronous belts are constructed using only "Z" twist cord. This construction provides an upward direction of lateral movement on vertical shaft drives to reduce wear on the bottom side of the belt.
Synchro-Cog® Timing Belt (XL, L, H, XH, XXH)	
	Synchronous belt with trapezoidal tooth profile for traditional synchronous applications.
Dual Synchro-Cog® Timing Belt (DXL, DL, DH, DXH, DXXH)	
	Double-sided timing belt with trapezoidal tooth profile. Provides synchronization and 100% load capacity from both sides of the belt.
Cotton Drive® Timing Belt (CCB)	
	1" pitch timing belt designed for use on cotton cleaning machines. Uniquely constructed to handle this harsh, abrasive application.
Power-Wedge® Cog-Belt® (3VX, 5VX, 8VX, XPZ, XPA, XPB, XPC)	
	Combines the advantages of the narrow wedge profile, EPDM and raw edge edge cog-belt performance for maximum operating efficiency in a compact drive package.
Power-Wedge® Cog-Band® (R3VX, R5VX)	
	Banded version of Power-Wedge Cog-Belt. Designed for pulsating, heavily shock loaded or drives with long center distances to minimize belt whip and rollover.

Timken Belts

The Right Belt for the Job®

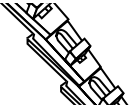
Super Power-Wedge® V-Belt (3V, 5V, 8V)	Double Angle V-Belt (AA, BB, CC)
 <p>Narrow wrapped molded v-belt enables design of a more compact belt drive. Ideal for heavy duty industrial drives with shock loads.</p>	 <p>Hexagonal belt designed for drives where power needs to be transmitted equally from both sides of the belt.</p>
Super Power-Wedge® Band (R3V, R5V, R8V, RSPZ, RSPA, RSPB, RSPC)	Durapower® II FHP V-Belt (2L-R, 3L-R, 4L-R, 5L-R)
 <p>Banded version of Super Power-Wedge v-belt. Designed for pulsating, heavily shock loaded or drives with long center distances to minimize belt whip and rollover.</p>	 <p>Light duty v-belt designed for fractional horsepower applications. EPDM, central cord placement and raw edge construction improves efficiency, performance and belt life.</p>
Aramax® Power-Wedge® V-Belt (5VK, 8VK, SPBK, SPCK)	Variable Speed Cog-Belt®
 <p>High performance narrow v-belt made with Aramid cord and designed for extraordinary belt strength on the toughest drives.</p>	 <p>Adjustable speed belt designed for use with industrial variable pitch pulleys to gain a wide range of driven speeds.</p>
Aramax® Power-Wedge® Band (R5VK, R8VK, RSPBK, RSPCK)	Vee-Rib™ Belt (J)
 <p>Designed for extraordinary banded belt strength on the toughest drives. Designed for pulsating, heavily shock loaded or drives with long center distances to minimize belt whip and rollover.</p>	 <p>Thin belt with v-shaped ribs running the length of the belt provide smooth, vibration-free performance in a compact drive. Designed for high speed drives where conventional v-belts cannot operate.</p>
Chipper Drive Wedge-Band® (R5VL)	Dry Can Belt (CC)
 <p>Laminated banded belt specially designed and constructed to meet the unique demands of the lumber industry. Banded belt construction minimizes belt whip and rollover.</p>	 <p>Designed with deep-groove notches specifically developed for double angle "CC" drives found in the textile industry. The deep groove minimizes belt rollover while the notches provide flexibility and long belt life.</p>
Gold-Ribbon® Cog-Belt® (AX, BX, CX, DX)	Feather Picker Belt (AAX-FP, BBX-FP)
 <p>The Energy Saver! Classical raw edge cog-belt combines EPDM, precision molded cogs and raw edge sidewalls to provide higher energy efficiency, increased power ratings and longer belt life than traditional wrapped v-belts.</p>	 <p>Double angle cog-belt provides superior performance on poultry processing equipment. Engineered for flexibility and enhanced grip in moist conditions.</p>
Gold-Ribbon® Cog-Band® (RBX, RCX)	Flour Power® Roller Mill Belt (8M/PVK, 14M/PVK)
 <p>Combines the superior characteristics of the Gold-Ribbon Cog-Belt with the stability of a banded belt. Designed for pulsating, heavily shock loaded or drives with long center distances to minimize belt whip and rollover.</p>	 <p>Specialty belt engineered for automated milling machines. Dual sided belt - one side is synchronous, the other v-ribbed.</p>
Super II® V-Belt (A-R, B-R, C-R)	Round Belt (7/16, 9/16)
 <p>The Problem Solver! Classical raw edge v-belt made with EPDM and central cord placement to create a flexible, stable and efficient v-belt.</p>	 <p>High performance solution for conveyors, quarterturn, twisted, and serpentine drives. Timken round belts feature a no-splice construction for added durability with minimal stretch.</p>
Super Blue Ribbon® V-Belt (A, B, C, D, E)	Super Arc® Belt (B-SA, 9/16-SA)
 <p>Premium wrapped molded v-belt built to the highest standards in the industry. Ideal for classical drives with shock loads.</p>	 <p>Specialty belt designed to provide improved flexibility, performance and extended belt life on live/power roller conveyor drives.</p>
Aramax® Xtra Duty V-Belt (3L-K, AK, BK)	Thoro-Twist™ V-Belting (3L, A, B, C)
 <p>Aramax XDV is a heavy-duty v-belt made with Aramid cord and a smooth clutching cover. Designed for outdoor power equipment and aggressive applications with heavy shock loads.</p>	 <p>Urethane belt designed for drives that have no take-up adjustment capability or for emergency replacement.</p>

Synchronous Belts

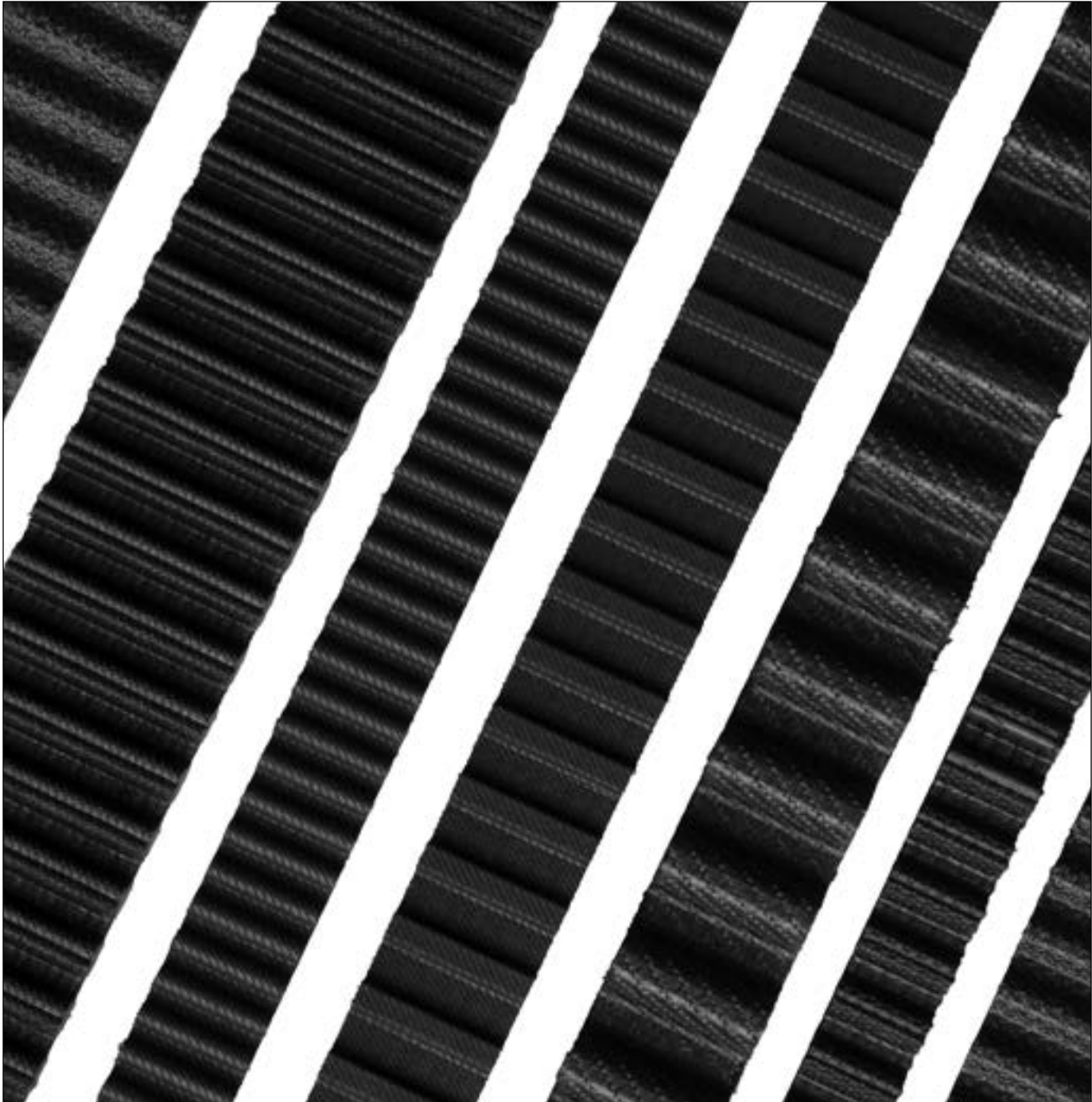



Synchronous (timing) belts are toothed belts in which power is transmitted through positive engagement between the belt teeth and a toothed sprocket (pulley). This positive engagement results in exact shaft synchronization while eliminating slippage and speed loss common to v-belts.

Trapezoidal, curvilinear, or modified curvilinear teeth mesh with matching grooves on sprockets to provide positive power transmission on high-torque applications with high and low speeds. A synchronous belt requires no re-tensioning, improves energy efficiency and reduces downtime.

Compared to chain, synchronous belts are more compact, lighter, quieter, require no lubrication and operate at higher speeds.

Timken synchronous drive systems offer quiet, efficient and maintenance free operation.

When to use a synchronous belt

- Synchronous transmission between shafts is a must
- High mechanical drive efficiency and energy savings required
- Precise relative positioning of shafts (non-slip and minimal backlash)
- Compact drive layout is necessary
- Low maintenance is required
- Combines power transmission and conveying needs
- Low noise requirements (compared to chain)
- Environmental or contamination concerns (no lubrication required)
- High torque, low RPM requirements

Synchronous Belts

Understanding Synchronous Belt Nomenclature

The part number for synchronous belts provides useful information – if you know how to look at it.

Example: **8MXT - 640 - 12**



Tooth Pitch in millimeters

- Spacing between two adjacent teeth on the belts
- Measured from the center of one tooth to the center of the next



Pitch Length

- Belt circumference in millimeters as measured along the pitch line
- Determined by multiplying the belt pitch by the number of teeth

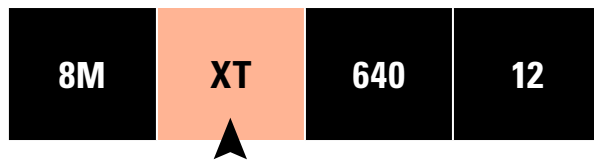

Belt Construction

- In this example XT represents Panther XT construction



Belt Width

- Width of belt in millimeters

Although different product lines will have different nomenclature, generally, throughout the industry, they all contain the same components. Refer to the handy chart below to assist in properly specifying the correct synchronous belt. Often times, these guidelines will be useful when crossing competitor belts to a Timken belt.

Synchronous Belt	Example Part Number				
Panther® XT	8MXT-640-12	8M	XT-	640-	12
Panther®	1400-8MPT-50	1400-	8M	PT-	50
Synchro-Cog® HT	144-3M-15	144-	3M-	15	
Dual Synchronous	D1200-8M-50	D	1200-	8M-	50
Synchro-Cog® Timing	210XL037	210	XL	37	
ACHE Belt	3150-14M-55F	3150-	14M-	55	F

■ Tooth Pitch
 ■ Belt Construction
 ■ Pitch Length
 ■ Belt Width

Please note: Different synchronous belt types must be used with the correct sprocket. Compatibility is critical for safety as well as optimum performance.

Panther[®]XT

Synchronous Drive Belt

PANTHER^{XT}

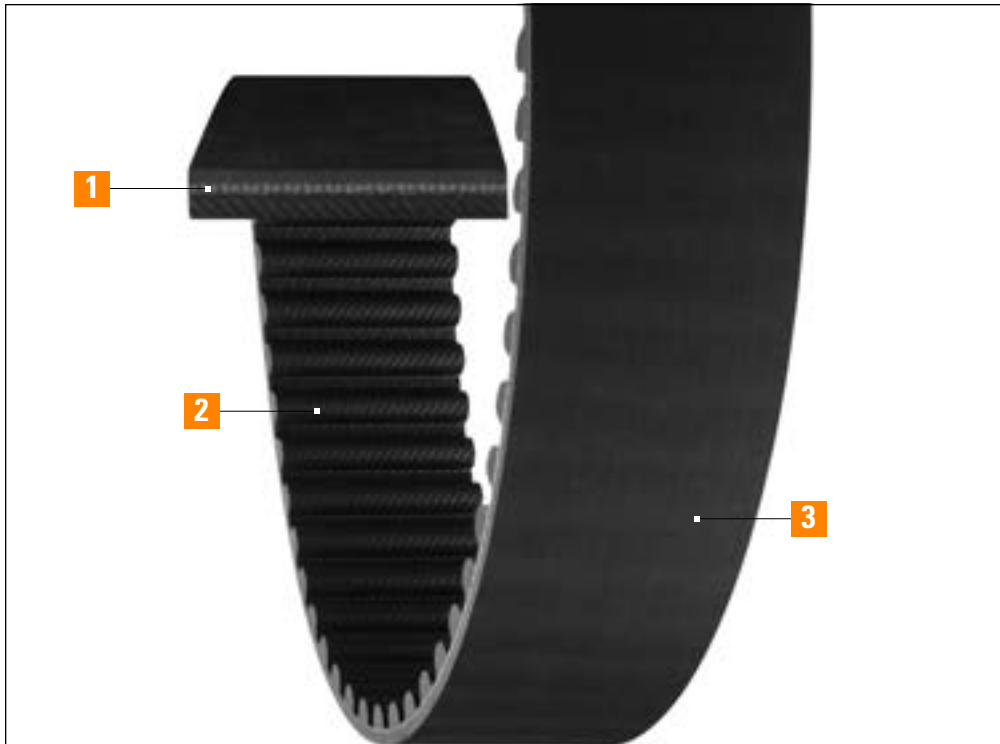

- 1 Carbon Cord Construction**
High-modulus carbon fiber cord
High tensile strength
Minimal stretch
Increased durability

- 2 Engineered Tooth Fabric**
Low-friction
Abrasion resistant
Extended belt life

- 3 Advanced Polymer Compound**
Reduced noise
High elasticity
Heat resistant (up to 120°C/248°F)
Oil resistant
High hardness
Improved performance in harsh conditions

Recommended Sprockets:
MPC Sprockets – MPB, Taper Bushed (8mm, 14mm)

Strong...
Like a Panther

Quiet...
Like a Panther

Runs...
Like a Panther

Purrs...
Like a Panther

Applications:
Printing machinery
Textile equipment
Packaging machinery
Compressors
Roller chain drives
Drop-in replacement for
polyurethane belts
& More

Synchronous Belts

V- Belts

Specialty Belts

Tools

General Information

Panther[®]XT

Synchronous Drive Belt

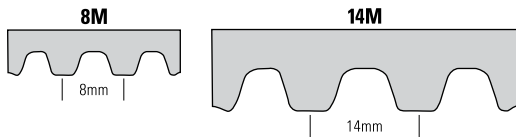

Our Panther[®]XT outlives the pack...by nine lives!

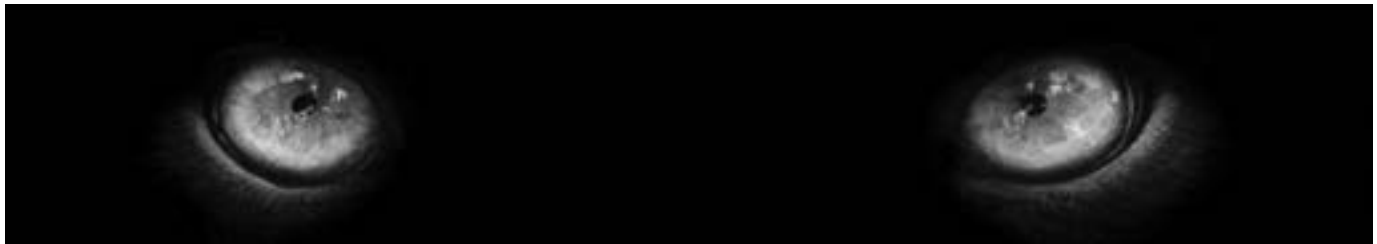

Panther[®]XT...PURRFECT TIMING

The strong, silent type, PantherXT is the extreme torque synchronous belt that purrrs.

A powerful alternative to chain or a drop-in replacement for polyurethane belts, Panther XT offers higher torque capacity than the Panther[®] RPP synchronous belt and is engineered to run quietly and efficiently in the harshest environments. Naturally agile, Panther XT moves quickly and easily to help achieve power ratings that meet or exceed the competition.

Carbon cord construction and abrasion-resistant, low friction tooth fabric promise the equivalent of nine lives of reduced downtime, maintenance, and noise levels.

RUNS like a panther

- Panther XT is engineered to achieve high power ratings
- Designed for efficiency, PantherXT minimizes drive widths resulting in more compact drive designs and reduced metal costs

STRONG like a panther

- Carbon cord construction with high tensile strength and minimal stretch increases durability
- Fabric is engineered to be low-friction and abrasion-resistant for extended belt life
- Oil/heat resistant up to 120°C/248°F
- An advanced polymer combines high elasticity and hardness for improved performance in harsh environments

QUIET like a panther

- Rubber construction and special fabric design reduce high frequency noise when compared to polyurethane belt construction

PANTHER[®]XT Break Strength Comparison

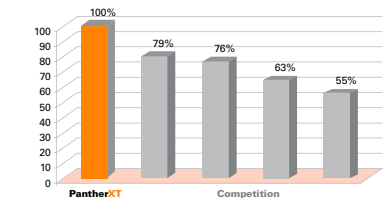

PANTHER[®]XT Belt Life Comparison

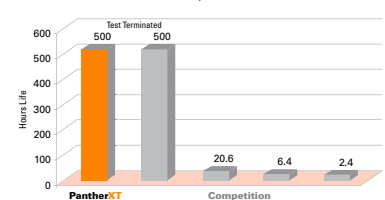

PANTHER[®]XT Maximum Operating Temperature

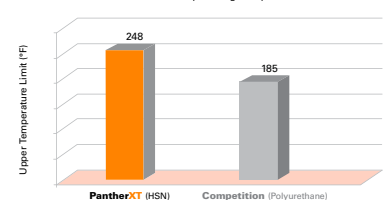

PANTHER[®]XT Tooth Shear Strength Comparison

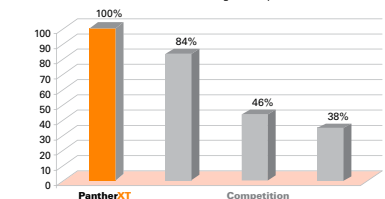

Panther[®]XT

Synchronous Drive Belt

Panther[®]XT Part Numbers

Part Number Example: **8MXT-640-12** = **8M** **XT** - **640** - **12**
Tooth Pitch PantherXT Construction Pitch Length (millimeters) Width (millimeters)

Part Number	Number Of Teeth	Pitch Length		Weight (lbs)
		(mm)	(in)	
8MXT Pitch – Recommended Sprockets: MPC Sprockets – MPB, Taper Bushed (8mm)				
8MXT-640-12	80	640	25.2	0.08
8MXT-640-21	80	640	25.2	0.14
8MXT-640-36	80	640	25.2	0.24
8MXT-640-62	80	640	25.2	0.41
8MXT-720-12	90	720	28.3	0.09
8MXT-720-21	90	720	28.3	0.16
8MXT-720-36	90	720	28.3	0.27
8MXT-720-62	90	720	28.3	0.46
8MXT-800-12	100	800	31.5	0.10
8MXT-800-21	100	800	31.5	0.17
8MXT-800-36	100	800	31.5	0.30
8MXT-800-62	100	800	31.5	0.51
8MXT-896-12	112	896	35.3	0.11
8MXT-896-21	112	896	35.3	0.19
8MXT-896-36	112	896	35.3	0.33
8MXT-896-62	112	896	35.3	0.57
8MXT-960-12	120	960	37.8	0.12
8MXT-960-21	120	960	37.8	0.21
8MXT-960-36	120	960	37.8	0.36
8MXT-960-62	120	960	37.8	0.62
8MXT-1000-12	125	1000	39.4	0.12
8MXT-1000-21	125	1000	39.4	0.22
8MXT-1000-36	125	1000	39.4	0.37
8MXT-1000-62	125	1000	39.4	0.64
8MXT-1040-12	130	1040	40.9	0.13
8MXT-1040-21	130	1040	40.9	0.23
8MXT-1040-36	130	1040	40.9	0.39
8MXT-1040-62	130	1040	40.9	0.67
8MXT-1120-12	140	1120	44.1	0.14
8MXT-1120-21	140	1120	44.1	0.24
8MXT-1120-36	140	1120	44.1	0.42
8MXT-1120-62	140	1120	44.1	0.72
8MXT-1200-12	150	1200	47.2	0.15

Part Number	Number Of Teeth	Pitch Length		Weight (lbs)
		(mm)	(in)	
8MXT Pitch – Recommended Sprockets: MPC Sprockets – MPB, Taper Bushed (8mm)				
8MXT-1200-21	150	1200	47.2	0.26
8MXT-1200-36	150	1200	47.2	0.45
8MXT-1200-62	150	1200	47.2	0.77
8MXT-1224-12	153	1224	48.2	0.15
8MXT-1224-21	153	1224	48.2	0.27
8MXT-1224-36	153	1224	48.2	0.46
8MXT-1224-62	153	1224	48.2	0.78
8MXT-1280-12	160	1280	50.4	0.16
8MXT-1280-21	160	1280	50.4	0.28
8MXT-1280-36	160	1280	50.4	0.48
8MXT-1280-62	160	1280	50.4	0.82
8MXT-1440-12	180	1440	56.7	0.18
8MXT-1440-21	180	1440	56.7	0.31
8MXT-1440-36	180	1440	56.7	0.54
8MXT-1440-62	180	1440	56.7	0.92
8MXT-1600-12	200	1600	63.0	0.20
8MXT-1600-21	200	1600	63.0	0.35
8MXT-1600-36	200	1600	63.0	0.60
8MXT-1600-62	200	1600	63.0	1.03
8MXT-1760-12	220	1760	69.3	0.22
8MXT-1760-21	220	1760	69.3	0.38
8MXT-1760-36	220	1760	69.3	0.66
8MXT-1760-62	220	1760	69.3	1.13
8MXT-1792-12	224	1792	70.6	0.22
8MXT-1792-21	224	1792	70.6	0.39
8MXT-1792-36	224	1792	70.6	0.67
8MXT-1792-62	224	1792	70.6	1.15
8MXT-2000-12	250	2000	78.7	0.25
8MXT-2000-21	250	2000	78.7	0.43
8MXT-2000-36	250	2000	78.7	0.74
8MXT-2000-62	250	2000	78.7	1.28
8MXT-2200-12	275	2200	86.6	0.27
8MXT-2200-21	275	2200	86.6	0.48

Panther[®]XT

Synchronous Drive Belt

Panther[®]XT Part Numbers

Part Number	Number Of Teeth	Pitch Length		Weight (lbs)
		(mm)	(in)	
8MXT Pitch – Recommended Sprockets: MPC Sprockets – MPB, Taper Bushed (8mm)				
8MXT-2200-36	275	2200	86.6	0.82
8MXT-2200-62	275	2200	86.6	1.41
8MXT-2240-12	280	2240	88.2	0.28
8MXT-2240-21	280	2240	88.2	0.49
8MXT-2240-36	280	2240	88.2	0.83
8MXT-2240-62	280	2240	88.2	1.44
8MXT-2400-12	300	2400	94.5	0.30
8MXT-2400-21	300	2400	94.5	0.52
8MXT-2400-36	300	2400	94.5	0.89
8MXT-2400-62	300	2400	94.5	1.54
8MXT-2520-12	315	2520	99.2	0.31
8MXT-2520-21	315	2520	99.2	0.55
8MXT-2520-36	315	2520	99.2	0.94
8MXT-2520-62	315	2520	99.2	1.62
8MXT-2600-12	325	2600	102.4	0.32
8MXT-2600-21	325	2600	102.4	0.56
8MXT-2600-36	325	2600	102.4	0.97
8MXT-2600-62	325	2600	102.4	1.67
8MXT-2800-12	350	2800	110.2	0.35
8MXT-2800-21	350	2800	110.2	0.61
8MXT-2800-36	350	2800	110.2	1.04
8MXT-2800-62	350	2800	110.2	1.79
8MXT-2840-12	355	2840	111.8	0.35
8MXT-2840-21	355	2840	111.8	0.62
8MXT-2840-36	355	2840	111.8	1.06
8MXT-2840-62	355	2840	111.8	1.82
8MXT-3048-12	381	3048	120.0	0.38
8MXT-3048-21	381	3048	120.0	0.66
8MXT-3048-36	381	3048	120.0	1.13
8MXT-3048-62	381	3048	120.0	1.95
8MXT-3200-12	400	3200	126.0	0.40
8MXT-3200-21	400	3200	126.0	0.69
8MXT-3200-36	400	3200	126.0	1.19

Part Number	Number Of Teeth	Pitch Length		Weight (lbs)
		(mm)	(in)	
8MXT Pitch – Recommended Sprockets: MPC Sprockets – MPB, Taper Bushed (8mm)				
8MXT-3200-62	400	3200	126.0	2.05
8MXT-3280-12	410	3280	129.1	0.41
8MXT-3280-21	410	3280	129.1	0.71
8MXT-3280-36	410	3280	129.1	1.22
8MXT-3280-62	410	3280	129.1	2.10
8MXT-3600-12	450	3600	141.7	0.45
8MXT-3600-21	450	3600	141.7	0.78
8MXT-3600-36	450	3600	141.7	1.34
8MXT-3600-62	450	3600	141.7	2.31
8MXT-4000-12	500	4000	157.5	0.50
8MXT-4000-21	500	4000	157.5	0.87
8MXT-4000-36	500	4000	157.5	1.49
8MXT-4000-62	500	4000	157.5	2.56
8MXT-4400-12	550	4400	173.2	0.55
8MXT-4400-21	550	4400	173.2	0.96
8MXT-4400-36	550	4400	173.2	1.64
8MXT-4400-62	550	4400	173.2	2.82
8MXT-4480-12	560	4480	176.4	0.56
8MXT-4480-21	560	4480	176.4	0.97
8MXT-4480-36	560	4480	176.4	1.67
8MXT-4480-62	560	4480	176.4	2.87
14MXT Pitch – Recommended Sprockets: MPC Sprockets – MPB, Taper Bushed (14mm)				
14MXT-994-20	71	994	39.1	0.36
14MXT-994-37	71	994	39.1	0.67
14MXT-994-68	71	994	39.1	1.24
14MXT-994-90	71	994	39.1	1.64
14MXT-994-125	71	994	39.1	2.28
14MXT-1120-20	80	1120	44.1	0.41
14MXT-1120-37	80	1120	44.1	0.76
14MXT-1120-68	80	1120	44.1	1.40
14MXT-1120-90	80	1120	44.1	1.85
14MXT-1120-125	80	1120	44.1	2.57

Panther[®]XT

Synchronous Drive Belt

Part Number Example: **14MXT-1400-90** = **14M** **XT** - **1400** - **90**

Tooth Pitch
PantherXT Construction
Pitch Length (millimeters)
Width (millimeters)

Part Number	Number Of Teeth	Pitch Length		Weight (lbs)
		(mm)	(in)	
14MXT Pitch – Recommended Sprockets: MPC Sprockets – MPB, Taper Bushed (14mm)				
14MXT-1190-20	85	1190	46.9	0.44
14MXT-1190-37	85	1190	46.9	0.81
14MXT-1190-68	85	1190	46.9	1.48
14MXT-1190-90	85	1190	46.9	1.96
14MXT-1190-125	85	1190	46.9	2.73
14MXT-1260-20	90	1260	49.6	0.46
14MXT-1260-37	90	1260	49.6	0.86
14MXT-1260-68	90	1260	49.6	1.57
14MXT-1260-90	90	1260	49.6	2.08
14MXT-1260-125	90	1260	49.6	2.89
14MXT-1400-20	100	1400	55.1	0.51
14MXT-1400-37	100	1400	55.1	0.95
14MXT-1400-68	100	1400	55.1	1.75
14MXT-1400-90	100	1400	55.1	2.31
14MXT-1400-125	100	1400	55.1	3.21
14MXT-1568-20	112	1568	61.7	0.58
14MXT-1568-37	112	1568	61.7	1.06
14MXT-1568-68	112	1568	61.7	1.96
14MXT-1568-90	112	1568	61.7	2.59
14MXT-1568-125	112	1568	61.7	3.60
14MXT-1610-20	115	1610	63.4	0.59
14MXT-1610-37	115	1610	63.4	1.09
14MXT-1610-68	115	1610	63.4	2.01
14MXT-1610-90	115	1610	63.4	2.66
14MXT-1610-125	115	1610	63.4	3.69
14MXT-1750-20	125	1750	68.9	0.64
14MXT-1750-37	125	1750	68.9	1.19
14MXT-1750-68	125	1750	68.9	2.18
14MXT-1750-90	125	1750	68.9	2.89
14MXT-1750-125	125	1750	68.9	4.01
14MXT-1890-20	135	1890	74.4	0.69
14MXT-1890-37	135	1890	74.4	1.28
14MXT-1890-68	135	1890	74.4	2.36

Part Number	Number Of Teeth	Pitch Length		Weight (lbs)
		(mm)	(in)	
14MXT Pitch – Recommended Sprockets: MPC Sprockets – MPB, Taper Bushed (14mm)				
14MXT-1890-90	135	1890	74.4	3.12
14MXT-1890-125	135	1890	74.4	4.33
14MXT-1960-20	140	1960	77.2	0.72
14MXT-1960-37	140	1960	77.2	1.33
14MXT-1960-68	140	1960	77.2	2.44
14MXT-1960-90	140	1960	77.2	3.24
14MXT-1960-125	140	1960	77.2	4.49
14MXT-2100-20	150	2100	82.7	0.77
14MXT-2100-37	150	2100	82.7	1.43
14MXT-2100-68	150	2100	82.7	2.62
14MXT-2100-90	150	2100	82.7	3.47
14MXT-2100-125	150	2100	82.7	4.81
14MXT-2240-20	160	2240	88.2	0.82
14MXT-2240-37	160	2240	88.2	1.52
14MXT-2240-68	160	2240	88.2	2.79
14MXT-2240-90	160	2240	88.2	3.70
14MXT-2240-125	160	2240	88.2	5.14
14MXT-2310-20	165	2310	90.9	0.85
14MXT-2310-37	165	2310	90.9	1.57
14MXT-2310-68	165	2310	90.9	2.88
14MXT-2310-90	165	2310	90.9	3.81
14MXT-2310-125	165	2310	90.9	5.30
14MXT-2380-20	170	2380	93.7	0.87
14MXT-2380-37	170	2380	93.7	1.62
14MXT-2380-68	170	2380	93.7	2.97
14MXT-2380-90	170	2380	93.7	3.93
14MXT-2380-125	170	2380	93.7	5.46
14MXT-2450-20	175	2450	96.5	0.90
14MXT-2450-37	175	2450	96.5	1.66
14MXT-2450-68	175	2450	96.5	3.06
14MXT-2450-90	175	2450	96.5	4.04
14MXT-2450-125	175	2450	96.5	5.62
14MXT-2520-20	180	2520	99.2	0.92

Panther[®]XT

Synchronous Drive Belt

Panther[®]XT Part Numbers

Part Number Example: **14MXT-2520-90** = **14M** **XT** - **2520** - **90**

Tooth Pitch
PantherXT Construction
Pitch Length (millimeters)
Width (millimeters)

Part Number	Number Of Teeth	Pitch Length		Weight (lbs)
		(mm)	(in)	
14MXT Pitch – Recommended Sprockets: MPC Sprockets – MPB, Taper Bushed (14mm)				
14MXT-2520-37	180	2520	99.2	1.71
14MXT-2520-68	180	2520	99.2	3.14
14MXT-2520-90	180	2520	99.2	4.16
14MXT-2520-125	180	2520	99.2	5.78
14MXT-2590-20	185	2590	102.0	0.95
14MXT-2590-37	185	2590	102.0	1.76
14MXT-2590-68	185	2590	102.0	3.23
14MXT-2590-90	185	2590	102.0	4.28
14MXT-2590-125	185	2590	102.0	5.94
14MXT-2660-20	190	2660	104.7	0.98
14MXT-2660-37	190	2660	104.7	1.81
14MXT-2660-68	190	2660	104.7	3.32
14MXT-2660-90	190	2660	104.7	4.39
14MXT-2660-125	190	2660	104.7	6.10
14MXT-2800-20	200	2800	110.2	1.03
14MXT-2800-37	200	2800	110.2	1.90
14MXT-2800-68	200	2800	110.2	3.49
14MXT-2800-90	200	2800	110.2	4.62
14MXT-2800-125	200	2800	110.2	6.42
14MXT-3136-20	224	3136	123.5	1.15
14MXT-3136-37	224	3136	123.5	2.13
14MXT-3136-68	224	3136	123.5	3.91
14MXT-3136-90	224	3136	123.5	5.18
14MXT-3136-125	224	3136	123.5	7.19
14MXT-3304-20	236	3304	130.1	1.21
14MXT-3304-37	236	3304	130.1	2.24
14MXT-3304-68	236	3304	130.1	4.12
14MXT-3304-90	236	3304	130.1	5.45
14MXT-3304-125	236	3304	130.1	7.58
14MXT-3360-20	240	3360	132.3	1.23
14MXT-3360-37	240	3360	132.3	2.28
14MXT-3360-68	240	3360	132.3	4.19
14MXT-3360-90	240	3360	132.3	5.55

Part Number	Number Of Teeth	Pitch Length		Weight (lbs)
		(mm)	(in)	
14MXT Pitch – Recommended Sprockets: MPC Sprockets – MPB, Taper Bushed (14mm)				
14MXT-3360-125	240	3360	132.3	7.70
14MXT-3500-20	250	3500	137.8	1.28
14MXT-3500-37	250	3500	137.8	2.38
14MXT-3500-68	250	3500	137.8	4.37
14MXT-3500-90	250	3500	137.8	5.78
14MXT-3500-125	250	3500	137.8	8.02
14MXT-3850-20	275	3850	151.6	1.41
14MXT-3850-37	275	3850	151.6	2.61
14MXT-3850-68	275	3850	151.6	4.80
14MXT-3850-90	275	3850	151.6	6.36
14MXT-3850-125	275	3850	151.6	8.83
14MXT-3920-20	280	3920	154.3	1.44
14MXT-3920-37	280	3920	154.3	2.66
14MXT-3920-68	280	3920	154.3	4.89
14MXT-3920-90	280	3920	154.3	6.47
14MXT-3920-125	280	3920	154.3	8.99
14MXT-4144-20	296	4144	163.1	1.51
14MXT-4144-37	296	4144	163.1	2.85
14MXT-4144-68	296	4144	163.1	5.10
14MXT-4144-90	296	4144	163.1	6.90
14MXT-4144-125	296	4144	163.1	9.51
14MXT-4326-20	309	4326	170.3	1.59
14MXT-4326-37	309	4326	170.3	2.94
14MXT-4326-68	309	4326	170.3	5.40
14MXT-4326-90	309	4326	170.3	7.14
14MXT-4326-125	309	4326	170.3	9.92
14MXT-4410-20	315	4410	173.6	1.62
14MXT-4410-37	315	4410	173.6	2.99
14MXT-4410-68	315	4410	173.6	5.50
14MXT-4410-90	315	4410	173.6	7.28
14MXT-4410-125	315	4410	173.6	10.11

Panther®

Synchronous Drive Belt



1 Ultra-Cord® Tensile Member
High strength
Low tension decay
Dimensional stability

2 Nylon Tooth Facing
Graphite-loaded
Self-lubricating
Wear resistant

3 RPP® Profile
Efficient transfer of power
Jump and shear resistant
Quiet

4 Rubber Backing
Precision-ground
Smooth operation with backside idler

5 Advanced Polymer Compound
Excellent performance
Long belt life

Recommended Sprockets:
High Torque Synchronous (HTS) Sprockets – MPB, OD, Taper Bushed (8mm, 14mm, 20mm)

Optimized tensile member

Advanced polymer compound

Maintenance-free

Energy efficient

Applications:

- Conveyors
- Blowers
- Packaging equipment
- Machine tools
- Industrial machinery & More

Panther®

Synchronous Drive Belt

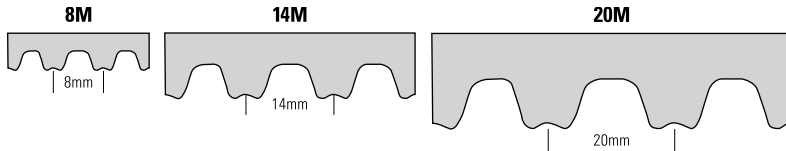

Panther® is designed to improve performance and drive life while reducing maintenance and downtime.

The energy efficient Panther® belt

offers higher torque capacity than Timken Synchro-Cog® HT belts..

- **Strong** – Panther belts shrugs off shock loads. Designed with Ultra-Cord, to deliver strength and dimensional stability.
- **Resilient** – Uniquely engineered teeth are made of an advanced polymer compound for high performance and long belt life. The tooth facing is graphite loaded, self-lubricating, and wear resistant. The RPP® profile offers superior performance in RPP, HTS and PGGT2® sprockets as well as HPPD, Hawk Pd® and HTD® sprockets.
- **Energy Efficient** – Panther belts perform at 98-99% operating efficiency for reduced energy consumption.
- **Panther Power** – Panther Panther belts are maintenance free while offering higher power ratings than conventional rubber synchronous belts. Available in 8, 14 and 20mm pitches.



Hawk Pd® is a registered trademark of Veyance Technologies, Inc. PGGT2® and HTD® are registered trademarks of Gates Corporation.

Panther® Synchronous Drive Belt

Panther® Part Numbers

Part Number Example: **1400-8MPT-50** = **1400** - **8M** **PT** - **50**
Pitch Length (millimeters) Tooth Pitch Panther Construction (RPP tooth profile) Width (millimeters)

Part Number	Number Of Teeth	Pitch Length		Weight (lbs)
		(mm)	(in)	
8M Pitch – High Torque Synchronous (HTS) Sprockets: MPB, QD, Taper Bushed (8mm)				
480-8MPT-12	60	480	18.9	0.07
480-8MPT-20	60	480	18.9	0.12
480-8MPT-22	60	480	18.9	0.13
480-8MPT-30	60	480	18.9	0.17
480-8MPT-35	60	480	18.9	0.20
480-8MPT-50	60	480	18.9	0.29
480-8MPT-60	60	480	18.9	0.35
480-8MPT-85	60	480	18.9	0.49
560-8MPT-12	70	560	22.0	0.08
560-8MPT-20	70	560	22.0	0.14
560-8MPT-22	70	560	22.0	0.15
560-8MPT-30	70	560	22.0	0.20
560-8MPT-35	70	560	22.0	0.24
560-8MPT-50	70	560	22.0	0.34
560-8MPT-60	70	560	22.0	0.41
560-8MPT-85	70	560	22.0	0.57
600-8MPT-12	75	600	23.6	0.09
600-8MPT-20	75	600	23.6	0.14
600-8MPT-22	75	600	23.6	0.16
600-8MPT-30	75	600	23.6	0.22
600-8MPT-35	75	600	23.6	0.25
600-8MPT-50	75	600	23.6	0.36
600-8MPT-60	75	600	23.6	0.43
600-8MPT-85	75	600	23.6	0.61
640-8MPT-12	80	640	25.2	0.09
640-8MPT-20	80	640	25.2	0.15
640-8MPT-22	80	640	25.2	0.17
640-8MPT-30	80	640	25.2	0.23
640-8MPT-35	80	640	25.2	0.27
640-8MPT-50	80	640	25.2	0.39
640-8MPT-60	80	640	25.2	0.46
640-8MPT-85	80	640	25.2	0.66
720-8MPT-12	90	720	28.3	0.10

Part Number	Number Of Teeth	Pitch Length		Weight (lbs)
		(mm)	(in)	
8M Pitch – High Torque Synchronous (HTS) Sprockets: MPB, QD, Taper Bushed (8mm)				
720-8MPT-20	90	720	28.3	0.17
720-8MPT-22	90	720	28.3	0.19
720-8MPT-30	90	720	28.3	0.26
720-8MPT-35	90	720	28.3	0.30
720-8MPT-50	90	720	28.3	0.43
720-8MPT-60	90	720	28.3	0.52
720-8MPT-85	90	720	28.3	0.74
800-8MPT-12	100	800	31.5	0.12
800-8MPT-20	100	800	31.5	0.19
800-8MPT-22	100	800	31.5	0.21
800-8MPT-30	100	800	31.5	0.29
800-8MPT-35	100	800	31.5	0.34
800-8MPT-50	100	800	31.5	0.48
800-8MPT-60	100	800	31.5	0.58
800-8MPT-85	100	800	31.5	0.82
880-8MPT-12	110	880	34.6	0.13
880-8MPT-20	110	880	34.6	0.21
880-8MPT-22	110	880	34.6	0.23
880-8MPT-30	110	880	34.6	0.32
880-8MPT-35	110	880	34.6	0.37
880-8MPT-50	110	880	34.6	0.53
880-8MPT-60	110	880	34.6	0.64
880-8MPT-85	110	880	34.6	0.90
896-8MPT-12	112	896	35.3	0.13
896-8MPT-20	112	896	35.3	0.22
896-8MPT-22	112	896	35.3	0.24
896-8MPT-30	112	896	35.3	0.32
896-8MPT-35	112	896	35.3	0.38
896-8MPT-50	112	896	35.3	0.54
896-8MPT-60	112	896	35.3	0.65
896-8MPT-85	112	896	35.3	0.92
920-8MPT-12	115	920	36.2	0.13
920-8MPT-20	115	920	36.2	0.22

Panther®

Synchronous Drive Belt

Panther®

Part Numbers

Part Number	Number Of Teeth	Pitch Length		Weight (lbs)
		(mm)	(in)	
8M Pitch – High Torque Synchronous (HTS) Sprockets: MPB, QD, Taper Bushed (8mm)				
920-8MPT-22	115	920	36.2	0.24
920-8MPT-30	115	920	36.2	0.33
920-8MPT-35	115	920	36.2	0.39
920-8MPT-50	115	920	36.2	0.55
920-8MPT-60	115	920	36.2	0.67
920-8MPT-85	115	920	36.2	0.94
960-8MPT-12	120	960	37.8	0.14
960-8MPT-20	120	960	37.8	0.23
960-8MPT-22	120	960	37.8	0.25
960-8MPT-30	120	960	37.8	0.35
960-8MPT-35	120	960	37.8	0.41
960-8MPT-50	120	960	37.8	0.58
960-8MPT-60	120	960	37.8	0.69
960-8MPT-85	120	960	37.8	0.98
1000-8MPT-12	125	1000	39.4	0.14
1000-8MPT-20	125	1000	39.4	0.24
1000-8MPT-22	125	1000	39.4	0.27
1000-8MPT-30	125	1000	39.4	0.36
1000-8MPT-35	125	1000	39.4	0.42
1000-8MPT-50	125	1000	39.4	0.60
1000-8MPT-60	125	1000	39.4	0.72
1000-8MPT-85	125	1000	39.4	1.02
1040-8MPT-12	130	1040	40.9	0.15
1040-8MPT-20	130	1040	40.9	0.25
1040-8MPT-22	130	1040	40.9	0.28
1040-8MPT-30	130	1040	40.9	0.38
1040-8MPT-35	130	1040	40.9	0.44
1040-8MPT-50	130	1040	40.9	0.63
1040-8MPT-60	130	1040	40.9	0.75
1040-8MPT-85	130	1040	40.9	1.07
1120-8MPT-12	140	1120	44.1	0.16
1120-8MPT-20	140	1120	44.1	0.27
1120-8MPT-22	140	1120	44.1	0.30

Part Number	Number Of Teeth	Pitch Length		Weight (lbs)
		(mm)	(in)	
8M Pitch – High Torque Synchronous (HTS) Sprockets: MPB, QD, Taper Bushed (8mm)				
1120-8MPT-30	140	1120	44.1	0.41
1120-8MPT-35	140	1120	44.1	0.47
1120-8MPT-50	140	1120	44.1	0.68
1120-8MPT-60	140	1120	44.1	0.81
1120-8MPT-85	140	1120	44.1	1.15
1152-8MPT-12	144	1152	45.4	0.17
1152-8MPT-20	144	1152	45.4	0.28
1152-8MPT-22	144	1152	45.4	0.31
1152-8MPT-30	144	1152	45.4	0.42
1152-8MPT-35	144	1152	45.4	0.49
1152-8MPT-50	144	1152	45.4	0.69
1152-8MPT-60	144	1152	45.4	0.83
1152-8MPT-85	144	1152	45.4	1.18
1200-8MPT-12	150	1200	47.2	0.17
1200-8MPT-20	150	1200	47.2	0.29
1200-8MPT-22	150	1200	47.2	0.32
1200-8MPT-30	150	1200	47.2	0.43
1200-8MPT-35	150	1200	47.2	0.51
1200-8MPT-50	150	1200	47.2	0.72
1200-8MPT-60	150	1200	47.2	0.87
1200-8MPT-85	150	1200	47.2	1.23
1224-8MPT-12	153	1224	48.2	0.18
1224-8MPT-20	153	1224	48.2	0.30
1224-8MPT-22	153	1224	48.2	0.32
1224-8MPT-30	153	1224	48.2	0.44
1224-8MPT-35	153	1224	48.2	0.52
1224-8MPT-50	153	1224	48.2	0.74
1224-8MPT-60	153	1224	48.2	0.89
1224-8MPT-85	153	1224	48.2	1.25
1248-8MPT-12	156	1248	49.1	0.18
1248-8MPT-20	156	1248	49.1	0.30
1248-8MPT-22	156	1248	49.1	0.33
1248-8MPT-30	156	1248	49.1	0.45

Panther® Synchronous Drive Belt

Part Number Example: **1400-8MPT-50** = **1400** - **8M** **PT** - **50**
Pitch Length (millimeters) Tooth Pitch Panther Construction (RPP tooth profile) Width (millimeters)

Part Number	Number Of Teeth	Pitch Length		Weight (lbs)
		(mm)	(in)	
8M Pitch – High Torque Synchronous (HTS) Sprockets: MPB, QD, Taper Bushed (8mm)				
1248-8MPT-35	156	1248	49.1	0.53
1248-8MPT-50	156	1248	49.1	0.75
1248-8MPT-60	156	1248	49.1	0.90
1248-8MPT-85	156	1248	49.1	1.28
1280-8MPT-12	160	1280	50.4	0.19
1280-8MPT-20	160	1280	50.4	0.31
1280-8MPT-22	160	1280	50.4	0.34
1280-8MPT-30	160	1280	50.4	0.46
1280-8MPT-35	160	1280	50.4	0.54
1280-8MPT-50	160	1280	50.4	0.77
1280-8MPT-60	160	1280	50.4	0.93
1280-8MPT-85	160	1280	50.4	1.31
1360-8MPT-12	170	1360	53.5	0.20
1360-8MPT-20	170	1360	53.5	0.33
1360-8MPT-22	170	1360	53.5	0.36
1360-8MPT-30	170	1360	53.5	0.49
1360-8MPT-35	170	1360	53.5	0.57
1360-8MPT-50	170	1360	53.5	0.82
1360-8MPT-60	170	1360	53.5	0.98
1360-8MPT-85	170	1360	53.5	1.39
1400-8MPT-12	175	1400	55.1	0.20
1400-8MPT-20	175	1400	55.1	0.34
1400-8MPT-22	175	1400	55.1	0.37
1400-8MPT-30	175	1400	55.1	0.51
1400-8MPT-35	175	1400	55.1	0.59
1400-8MPT-50	175	1400	55.1	0.84
1400-8MPT-60	175	1400	55.1	1.01
1400-8MPT-85	175	1400	55.1	1.43
1440-8MPT-12	180	1440	56.7	0.21
1440-8MPT-20	180	1440	56.7	0.35
1440-8MPT-22	180	1440	56.7	0.38
1440-8MPT-30	180	1440	56.7	0.52
1440-8MPT-35	180	1440	56.7	0.61

Part Number	Number Of Teeth	Pitch Length		Weight (lbs)
		(mm)	(in)	
8M Pitch – High Torque Synchronous (HTS) Sprockets: MPB, QD, Taper Bushed (8mm)				
1440-8MPT-50	180	1440	56.7	0.87
1440-8MPT-60	180	1440	56.7	1.04
1440-8MPT-85	180	1440	56.7	1.48
1600-8MPT-12	200	1600	63.0	0.23
1600-8MPT-20	200	1600	63.0	0.39
1600-8MPT-22	200	1600	63.0	0.42
1600-8MPT-30	200	1600	63.0	0.58
1600-8MPT-35	200	1600	63.0	0.68
1600-8MPT-50	200	1600	63.0	0.96
1600-8MPT-60	200	1600	63.0	1.16
1600-8MPT-85	200	1600	63.0	1.64
1760-8MPT-12	220	1760	69.3	0.25
1760-8MPT-20	220	1760	69.3	0.42
1760-8MPT-22	220	1760	69.3	0.47
1760-8MPT-30	220	1760	69.3	0.64
1760-8MPT-35	220	1760	69.3	0.74
1760-8MPT-50	220	1760	69.3	1.06
1760-8MPT-60	220	1760	69.3	1.27
1760-8MPT-85	220	1760	69.3	1.80
1800-8MPT-12	225	1800	70.9	0.26
1800-8MPT-20	225	1800	70.9	0.43
1800-8MPT-22	225	1800	70.9	0.48
1800-8MPT-30	225	1800	70.9	0.65
1800-8MPT-35	225	1800	70.9	0.76
1800-8MPT-50	225	1800	70.9	1.09
1800-8MPT-60	225	1800	70.9	1.30
1800-8MPT-85	225	1800	70.9	1.84
1904-8MPT-12	238	1904	75.0	0.28
1904-8MPT-20	238	1904	75.0	0.46
1904-8MPT-22	238	1904	75.0	0.51
1904-8MPT-30	238	1904	75.0	0.69
1904-8MPT-35	238	1904	75.0	0.80
1904-8MPT-50	238	1904	75.0	1.15

Panther®

Synchronous Drive Belt

Panther®

Part Numbers

Part Number	Number Of Teeth	Pitch Length		Weight (lbs)
		(mm)	(in)	
8M Pitch – High Torque Synchronous (HTS) Sprockets: MPB, QD, Taper Bushed (8mm)				
1904-8MPT-60	238	1904	75.0	1.38
1904-8MPT-85	238	1904	75.0	1.95
2000-8MPT-12	250	2000	78.7	0.29
2000-8MPT-20	250	2000	78.7	0.48
2000-8MPT-22	250	2000	78.7	0.53
2000-8MPT-30	250	2000	78.7	0.72
2000-8MPT-35	250	2000	78.7	0.84
2000-8MPT-50	250	2000	78.7	1.21
2000-8MPT-60	250	2000	78.7	1.45
2000-8MPT-85	250	2000	78.7	2.05
2104-8MPT-12	263	2104	82.8	0.30
2104-8MPT-20	263	2104	82.8	0.51
2104-8MPT-22	263	2104	82.8	0.56
2104-8MPT-30	263	2104	82.8	0.76
2104-8MPT-35	263	2104	82.8	0.89
2104-8MPT-50	263	2104	82.8	1.27
2104-8MPT-60	263	2104	82.8	1.52
2104-8MPT-85	263	2104	82.8	2.16
2200-8MPT-12	275	2200	86.6	0.32
2200-8MPT-20	275	2200	86.6	0.53
2200-8MPT-22	275	2200	86.6	0.58
2200-8MPT-30	275	2200	86.6	0.80
2200-8MPT-35	275	2200	86.6	0.93
2200-8MPT-50	275	2200	86.6	1.33
2200-8MPT-60	275	2200	86.6	1.59
2200-8MPT-85	275	2200	86.6	2.25
2240-8MPT-12	280	2240	88.2	0.32
2240-8MPT-20	280	2240	88.2	0.54
2240-8MPT-22	280	2240	88.2	0.59
2240-8MPT-30	280	2240	88.2	0.81
2240-8MPT-35	280	2240	88.2	0.95
2240-8MPT-50	280	2240	88.2	1.35
2240-8MPT-60	280	2240	88.2	1.62

Part Number	Number Of Teeth	Pitch Length		Weight (lbs)
		(mm)	(in)	
8M Pitch – High Torque Synchronous (HTS) Sprockets: MPB, QD, Taper Bushed (8mm)				
2240-8MPT-85	280	2240	88.2	2.30
2400-8MPT-12	300	2400	94.5	0.35
2400-8MPT-20	300	2400	94.5	0.58
2400-8MPT-22	300	2400	94.5	0.64
2400-8MPT-30	300	2400	94.5	0.87
2400-8MPT-35	300	2400	94.5	1.01
2400-8MPT-50	300	2400	94.5	1.45
2400-8MPT-60	300	2400	94.5	1.74
2400-8MPT-85	300	2400	94.5	2.46
2600-8MPT-12	325	2600	102.4	0.38
2600-8MPT-20	325	2600	102.4	0.63
2600-8MPT-22	325	2600	102.4	0.69
2600-8MPT-30	325	2600	102.4	0.94
2600-8MPT-35	325	2600	102.4	1.10
2600-8MPT-50	325	2600	102.4	1.57
2600-8MPT-60	325	2600	102.4	1.88
2600-8MPT-85	325	2600	102.4	2.66
2800-8MPT-12	350	2800	110.2	0.41
2800-8MPT-20	350	2800	110.2	0.68
2800-8MPT-22	350	2800	110.2	0.74
2800-8MPT-30	350	2800	110.2	1.01
2800-8MPT-35	350	2800	110.2	1.18
2800-8MPT-50	350	2800	110.2	1.69
2800-8MPT-60	350	2800	110.2	2.03
2800-8MPT-85	350	2800	110.2	2.87
3048-8MPT-12	381	3048	120.0	0.44
3048-8MPT-20	381	3048	120.0	0.74
3048-8MPT-22	381	3048	120.0	0.81
3048-8MPT-30	381	3048	120.0	1.10
3048-8MPT-35	381	3048	120.0	1.29
3048-8MPT-50	381	3048	120.0	1.84
3048-8MPT-60	381	3048	120.0	2.21
3048-8MPT-85	381	3048	120.0	3.12

Panther® Synchronous Drive Belt

Part Number Example: **2240-8MPT-85** = **2240** - **8M** **PT** - **85**
Pitch Length (millimeters) Tooth Pitch Panther Construction (RPP tooth profile) Width (millimeters)

Part Number	Number Of Teeth	Pitch Length		Weight (lbs)
		(mm)	(in)	
8M Pitch – High Torque Synchronous (HTS) Sprockets: MPB, QD, Taper Bushed (8mm)				
3280-8MPT-12	410	3280	129.1	0.47
3280-8MPT-20	410	3280	129.1	0.79
3280-8MPT-22	410	3280	129.1	0.87
3280-8MPT-30	410	3280	129.1	1.19
3280-8MPT-35	410	3280	129.1	1.38
3280-8MPT-50	410	3280	129.1	1.98
3280-8MPT-60	410	3280	129.1	2.37
3280-8MPT-85	410	3280	129.1	3.36
3600-8MPT-12	450	3600	141.7	0.52
3600-8MPT-20	450	3600	141.7	0.87
3600-8MPT-22	450	3600	141.7	0.96
3600-8MPT-30	450	3600	141.7	1.30
3600-8MPT-35	450	3600	141.7	1.52
3600-8MPT-50	450	3600	141.7	2.17
3600-8MPT-60	450	3600	141.7	2.60
3600-8MPT-85	450	3600	141.7	3.69
4400-8MPT-12	550	4400	173.2	0.64
4400-8MPT-20	550	4400	173.2	1.06
4400-8MPT-22	550	4400	173.2	1.17
4400-8MPT-30	550	4400	173.2	1.59
4400-8MPT-35	550	4400	173.2	1.86
4400-8MPT-50	550	4400	173.2	2.65
4400-8MPT-60	550	4400	173.2	3.18
4400-8MPT-85	550	4400	173.2	4.51
14M Pitch – High Torque Synchronous (HTS) Sprockets: MPB, QD, Taper Bushed (14mm)				
966-14MPT-20	69	966	38.0	0.39
966-14MPT-40	69	966	38.0	0.77
966-14MPT-42	69	966	38.0	0.81
966-14MPT-55	69	966	38.0	1.06
966-14MPT-65	69	966	38.0	1.26
966-14MPT-85	69	966	38.0	1.65
966-14MPT-90	69	966	38.0	1.74

Part Number	Number Of Teeth	Pitch Length		Weight (lbs)
		(mm)	(in)	
14M Pitch – High Torque Synchronous (HTS) Sprockets: MPB, QD, Taper Bushed (14mm)				
966-14MPT-115	69	966	38.0	2.23
966-14MPT-120	69	966	38.0	2.32
966-14MPT-170	69	966	38.0	3.29
1092-14MPT-20	78	1092	43.0	0.44
1092-14MPT-40	78	1092	43.0	0.88
1092-14MPT-42	78	1092	43.0	0.92
1092-14MPT-55	78	1092	43.0	1.20
1092-14MPT-65	78	1092	43.0	1.42
1092-14MPT-85	78	1092	43.0	1.86
1092-14MPT-90	78	1092	43.0	1.97
1092-14MPT-115	78	1092	43.0	2.52
1092-14MPT-120	78	1092	43.0	2.63
1092-14MPT-170	78	1092	43.0	3.72
1190-14MPT-20	85	1190	46.9	0.48
1190-14MPT-40	85	1190	46.9	0.95
1190-14MPT-42	85	1190	46.9	1.00
1190-14MPT-55	85	1190	46.9	1.31
1190-14MPT-65	85	1190	46.9	1.55
1190-14MPT-85	85	1190	46.9	2.03
1190-14MPT-90	85	1190	46.9	2.15
1190-14MPT-115	85	1190	46.9	2.74
1190-14MPT-120	85	1190	46.9	2.86
1190-14MPT-170	85	1190	46.9	4.05
1400-14MPT-20	100	1400	55.1	0.56
1400-14MPT-40	100	1400	55.1	1.12
1400-14MPT-42	100	1400	55.1	1.18
1400-14MPT-55	100	1400	55.1	1.54
1400-14MPT-65	100	1400	55.1	1.82
1400-14MPT-85	100	1400	55.1	2.38
1400-14MPT-90	100	1400	55.1	2.52
1400-14MPT-115	100	1400	55.1	3.23
1400-14MPT-120	100	1400	55.1	3.37
1400-14MPT-170	100	1400	55.1	4.77

Panther®

Synchronous Drive Belt

Panther® Part Numbers

Part Number	Number Of Teeth	Pitch Length		Weight (lbs)
		(mm)	(in)	
14M Pitch – High Torque Synchronous (HTS) Sprockets: MPB, OD, Taper Bushed (14mm)				
1610-14MPT-20	115	1610	63.4	0.65
1610-14MPT-40	115	1610	63.4	1.29
1610-14MPT-42	115	1610	63.4	1.35
1610-14MPT-55	115	1610	63.4	1.77
1610-14MPT-65	115	1610	63.4	2.10
1610-14MPT-85	115	1610	63.4	2.74
1610-14MPT-90	115	1610	63.4	2.90
1610-14MPT-115	115	1610	63.4	3.71
1610-14MPT-120	115	1610	63.4	3.87
1610-14MPT-170	115	1610	63.4	5.48
1750-14MPT-20	125	1750	68.9	0.70
1750-14MPT-40	125	1750	68.9	1.40
1750-14MPT-42	125	1750	68.9	1.47
1750-14MPT-55	125	1750	68.9	1.93
1750-14MPT-65	125	1750	68.9	2.28
1750-14MPT-85	125	1750	68.9	2.98
1750-14MPT-90	125	1750	68.9	3.16
1750-14MPT-115	125	1750	68.9	4.03
1750-14MPT-120	125	1750	68.9	4.21
1750-14MPT-170	125	1750	68.9	5.96
1764-14MPT-20	126	1764	69.4	0.71
1764-14MPT-40	126	1764	69.4	1.41
1764-14MPT-42	126	1764	69.4	1.48
1764-14MPT-55	126	1764	69.4	1.94
1764-14MPT-65	126	1764	69.4	2.30
1764-14MPT-85	126	1764	69.4	3.00
1764-14MPT-90	126	1764	69.4	3.18
1764-14MPT-115	126	1764	69.4	4.06
1764-14MPT-120	126	1764	69.4	4.24
1764-14MPT-170	126	1764	69.4	6.01
1778-14MPT-20	127	1778	70.0	0.71
1778-14MPT-40	127	1778	70.0	1.43
1778-14MPT-42	127	1778	70.0	1.50

Part Number	Number Of Teeth	Pitch Length		Weight (lbs)
		(mm)	(in)	
14M Pitch – High Torque Synchronous (HTS) Sprockets: MPB, OD, Taper Bushed (14mm)				
1778-14MPT-55	127	1778	70.0	1.96
1778-14MPT-65	127	1778	70.0	2.32
1778-14MPT-85	127	1778	70.0	3.03
1778-14MPT-90	127	1778	70.0	3.21
1778-14MPT-115	127	1778	70.0	4.10
1778-14MPT-120	127	1778	70.0	4.28
1778-14MPT-170	127	1778	70.0	6.06
1792-14MPT-20	128	1792	70.6	0.72
1792-14MPT-40	128	1792	70.6	1.44
1792-14MPT-42	128	1792	70.6	1.51
1792-14MPT-55	128	1792	70.6	1.97
1792-14MPT-65	128	1792	70.6	2.33
1792-14MPT-85	128	1792	70.6	3.05
1792-14MPT-90	128	1792	70.6	3.23
1792-14MPT-115	128	1792	70.6	4.13
1792-14MPT-120	128	1792	70.6	4.31
1792-14MPT-170	128	1792	70.6	6.10
1820-14MPT-20	130	1820	71.7	0.73
1820-14MPT-40	130	1820	71.7	1.46
1820-14MPT-42	130	1820	71.7	1.53
1820-14MPT-55	130	1820	71.7	2.01
1820-14MPT-65	130	1820	71.7	2.37
1820-14MPT-85	130	1820	71.7	3.10
1820-14MPT-90	130	1820	71.7	3.28
1820-14MPT-115	130	1820	71.7	4.19
1820-14MPT-120	130	1820	71.7	4.38
1820-14MPT-170	130	1820	71.7	6.20
1848-14MPT-20	132	1848	72.8	0.74
1848-14MPT-40	132	1848	72.8	1.48
1848-14MPT-42	132	1848	72.8	1.56
1848-14MPT-55	132	1848	72.8	2.04
1848-14MPT-65	132	1848	72.8	2.41
1848-14MPT-85	132	1848	72.8	3.15

Panther® Synchronous Drive Belt

Part Number Example: **1610-14MPT-20** = **1610** - **14M** **PT** - **20**
Pitch Length (millimeters) Tooth Pitch Panther Construction (RPP tooth profile) Width (millimeters)

Part Number	Number Of Teeth	Pitch Length		Weight (lbs)
		(mm)	(in)	
14M Pitch – High Torque Synchronous (HTS) Sprockets: MPB, QD, Taper Bushed (14mm)				
1848-14MPT-90	132	1848	72.8	3.33
1848-14MPT-115	132	1848	72.8	4.26
1848-14MPT-120	132	1848	72.8	4.44
1848-14MPT-170	132	1848	72.8	6.29
1862-14MPT-20	133	1862	73.3	0.75
1862-14MPT-40	133	1862	73.3	1.49
1862-14MPT-42	133	1862	73.3	1.57
1862-14MPT-55	133	1862	73.3	2.05
1862-14MPT-65	133	1862	73.3	2.43
1862-14MPT-85	133	1862	73.3	3.17
1862-14MPT-90	133	1862	73.3	3.36
1862-14MPT-115	133	1862	73.3	4.29
1862-14MPT-120	133	1862	73.3	4.48
1862-14MPT-170	133	1862	73.3	6.34
1890-14MPT-20	135	1890	74.4	0.76
1890-14MPT-40	135	1890	74.4	1.51
1890-14MPT-42	135	1890	74.4	1.59
1890-14MPT-55	135	1890	74.4	2.08
1890-14MPT-65	135	1890	74.4	2.46
1890-14MPT-85	135	1890	74.4	3.22
1890-14MPT-90	135	1890	74.4	3.41
1890-14MPT-115	135	1890	74.4	4.36
1890-14MPT-120	135	1890	74.4	4.54
1890-14MPT-170	135	1890	74.4	6.44
1904-14MPT-20	136	1904	75.0	0.76
1904-14MPT-40	136	1904	75.0	1.53
1904-14MPT-42	136	1904	75.0	1.60
1904-14MPT-55	136	1904	75.0	2.10
1904-14MPT-65	136	1904	75.0	2.48
1904-14MPT-85	136	1904	75.0	3.24
1904-14MPT-90	136	1904	75.0	3.43
1904-14MPT-115	136	1904	75.0	4.39
1904-14MPT-120	136	1904	75.0	4.58

Part Number	Number Of Teeth	Pitch Length		Weight (lbs)
		(mm)	(in)	
14M Pitch – High Torque Synchronous (HTS) Sprockets: MPB, QD, Taper Bushed (14mm)				
1904-14MPT-170	136	1904	75.0	6.49
1960-14MPT-20	140	1960	77.2	0.79
1960-14MPT-40	140	1960	77.2	1.57
1960-14MPT-42	140	1960	77.2	1.65
1960-14MPT-55	140	1960	77.2	2.16
1960-14MPT-65	140	1960	77.2	2.55
1960-14MPT-85	140	1960	77.2	3.34
1960-14MPT-90	140	1960	77.2	3.53
1960-14MPT-115	140	1960	77.2	4.52
1960-14MPT-120	140	1960	77.2	4.71
1960-14MPT-170	140	1960	77.2	6.68
2100-14MPT-20	150	2100	82.7	0.84
2100-14MPT-40	150	2100	82.7	1.68
2100-14MPT-42	150	2100	82.7	1.77
2100-14MPT-55	150	2100	82.7	2.31
2100-14MPT-65	150	2100	82.7	2.74
2100-14MPT-85	150	2100	82.7	3.58
2100-14MPT-90	150	2100	82.7	3.79
2100-14MPT-115	150	2100	82.7	4.84
2100-14MPT-120	150	2100	82.7	5.05
2100-14MPT-170	150	2100	82.7	7.15
2310-14MPT-20	165	2310	90.9	0.93
2310-14MPT-40	165	2310	90.9	1.85
2310-14MPT-42	165	2310	90.9	1.94
2310-14MPT-55	165	2310	90.9	2.55
2310-14MPT-65	165	2310	90.9	3.01
2310-14MPT-85	165	2310	90.9	3.93
2310-14MPT-90	165	2310	90.9	4.17
2310-14MPT-115	165	2310	90.9	5.32
2310-14MPT-120	165	2310	90.9	5.55
2310-14MPT-170	165	2310	90.9	7.87
2450-14MPT-20	175	2450	96.5	0.98
2450-14MPT-40	175	2450	96.5	1.96

Panther®

Synchronous Drive Belt

Panther®

Part Numbers

Part Number	Number Of Teeth	Pitch Length		Weight (lbs)
		(mm)	(in)	
14M Pitch – High Torque Synchronous (HTS) Sprockets: MPB, OD, Taper Bushed (14mm)				
2450-14MPT-42	175	2450	96.5	2.06
2450-14MPT-55	175	2450	96.5	2.70
2450-14MPT-65	175	2450	96.5	3.19
2450-14MPT-85	175	2450	96.5	4.17
2450-14MPT-90	175	2450	96.5	4.42
2450-14MPT-115	175	2450	96.5	5.65
2450-14MPT-120	175	2450	96.5	5.89
2450-14MPT-170	175	2450	96.5	8.35
2590-14MPT-20	185	2590	102.0	1.04
2590-14MPT-40	185	2590	102.0	2.08
2590-14MPT-42	185	2590	102.0	2.18
2590-14MPT-55	185	2590	102.0	2.85
2590-14MPT-65	185	2590	102.0	3.37
2590-14MPT-85	185	2590	102.0	4.41
2590-14MPT-90	185	2590	102.0	4.67
2590-14MPT-115	185	2590	102.0	5.97
2590-14MPT-120	185	2590	102.0	6.23
2590-14MPT-170	185	2590	102.0	8.82
2800-14MPT-20	200	2800	110.2	1.12
2800-14MPT-40	200	2800	110.2	2.24
2800-14MPT-42	200	2800	110.2	2.36
2800-14MPT-55	200	2800	110.2	3.09
2800-14MPT-65	200	2800	110.2	3.65
2800-14MPT-85	200	2800	110.2	4.77
2800-14MPT-90	200	2800	110.2	5.05
2800-14MPT-115	200	2800	110.2	6.45
2800-14MPT-120	200	2800	110.2	6.73
2800-14MPT-170	200	2800	110.2	9.54
3150-14MPT-20	225	3150	124.0	1.26
3150-14MPT-40	225	3150	124.0	2.52
3150-14MPT-42	225	3150	124.0	2.65
3150-14MPT-55	225	3150	124.0	3.47
3150-14MPT-65	225	3150	124.0	4.10

Part Number	Number Of Teeth	Pitch Length		Weight (lbs)
		(mm)	(in)	
14M Pitch – High Torque Synchronous (HTS) Sprockets: MPB, OD, Taper Bushed (14mm)				
3150-14MPT-85	225	3150	124.0	5.36
3150-14MPT-90	225	3150	124.0	5.68
3150-14MPT-115	225	3150	124.0	7.26
3150-14MPT-120	225	3150	124.0	7.57
3150-14MPT-170	225	3150	124.0	10.73
3360-14MPT-20	240	3360	132.3	1.35
3360-14MPT-40	240	3360	132.3	2.69
3360-14MPT-42	240	3360	132.3	2.83
3360-14MPT-55	240	3360	132.3	3.70
3360-14MPT-65	240	3360	132.3	4.38
3360-14MPT-85	240	3360	132.3	5.72
3360-14MPT-90	240	3360	132.3	6.06
3360-14MPT-115	240	3360	132.3	7.74
3360-14MPT-120	240	3360	132.3	8.08
3360-14MPT-170	240	3360	132.3	11.45
3500-14MPT-20	250	3500	137.8	1.40
3500-14MPT-40	250	3500	137.8	2.81
3500-14MPT-42	250	3500	137.8	2.95
3500-14MPT-55	250	3500	137.8	3.86
3500-14MPT-65	250	3500	137.8	4.56
3500-14MPT-85	250	3500	137.8	5.96
3500-14MPT-90	250	3500	137.8	6.31
3500-14MPT-115	250	3500	137.8	8.07
3500-14MPT-120	250	3500	137.8	8.42
3500-14MPT-170	250	3500	137.8	11.92
3850-14MPT-20	275	3850	151.6	1.54
3850-14MPT-40	275	3850	151.6	3.09
3850-14MPT-42	275	3850	151.6	3.24
3850-14MPT-55	275	3850	151.6	4.24
3850-14MPT-65	275	3850	151.6	5.01
3850-14MPT-85	275	3850	151.6	6.56
3850-14MPT-90	275	3850	151.6	6.94
3850-14MPT-115	275	3850	151.6	8.87

Panther® Synchronous Drive Belt

Part Number Example: **2450-14MPT-42** = **2450** - **14M** **PT** - **42**
Pitch Length (millimeters) Tooth Pitch Panther Construction (RPP tooth profile) Width (millimeters)

Part Number	Number Of Teeth	Pitch Length		Weight (lbs)
		(mm)	(in)	
14M Pitch – High Torque Synchronous (HTS) Sprockets: MPB, QD, Taper Bushed (14mm)				
3850-14MPT-120	275	3850	151.6	9.26
3850-14MPT-170	275	3850	151.6	13.11
4326-14MPT-20	309	4326	170.3	1.73
4326-14MPT-40	309	4326	170.3	3.47
4326-14MPT-42	309	4326	170.3	3.64
4326-14MPT-55	309	4326	170.3	4.77
4326-14MPT-65	309	4326	170.3	5.63
4326-14MPT-85	309	4326	170.3	7.37
4326-14MPT-90	309	4326	170.3	7.80
4326-14MPT-115	309	4326	170.3	9.97
4326-14MPT-120	309	4326	170.3	10.40
4326-14MPT-170	309	4326	170.3	14.74
4578-14MPT-20	327	4578	180.2	1.83
4578-14MPT-40	327	4578	180.2	3.67
4578-14MPT-42	327	4578	180.2	3.85
4578-14MPT-55	327	4578	180.2	5.05
4578-14MPT-65	327	4578	180.2	5.96
4578-14MPT-85	327	4578	180.2	7.80
4578-14MPT-90	327	4578	180.2	8.26
4578-14MPT-115	327	4578	180.2	10.55
4578-14MPT-120	327	4578	180.2	11.01
4578-14MPT-170	327	4578	180.2	15.59
4956-14MPT-20	354	4956	195.1	1.99
4956-14MPT-40	354	4956	195.1	3.97
4956-14MPT-42	354	4956	195.1	4.17
4956-14MPT-55	354	4956	195.1	5.46
4956-14MPT-65	354	4956	195.1	6.45
4956-14MPT-85	354	4956	195.1	8.44
4956-14MPT-90	354	4956	195.1	8.94
4956-14MPT-115	354	4956	195.1	11.42
4956-14MPT-120	354	4956	195.1	11.92
4956-14MPT-170	354	4956	195.1	16.88

Part Number	Number Of Teeth	Pitch Length		Weight (lbs)
		(mm)	(in)	
20M Pitch – High Torque Synchronous (HTS) Sprockets: MPB, QD, Taper Bushed (20mm)				
2000-20MPT-115	100	2000	78.7	7.46
2000-20MPT-170	100	2000	78.7	11.03
2000-20MPT-230	100	2000	78.7	14.92
2000-20MPT-290	100	2000	78.7	18.81
2000-20MPT-340	100	2000	78.7	22.06
2500-20MPT-115	125	2500	98.4	9.33
2500-20MPT-170	125	2500	98.4	13.79
2500-20MPT-230	125	2500	98.4	18.65
2500-20MPT-290	125	2500	98.4	23.52
2500-20MPT-340	125	2500	98.4	27.57
3400-20MPT-115	170	3400	133.9	12.68
3400-20MPT-170	170	3400	133.9	18.75
3400-20MPT-230	170	3400	133.9	25.37
3400-20MPT-290	170	3400	133.9	31.98
3400-20MPT-340	170	3400	133.9	37.50
3800-20MPT-115	190	3800	149.6	14.17
3800-20MPT-170	190	3800	149.6	20.95
3800-20MPT-230	190	3800	149.6	28.35
3800-20MPT-290	190	3800	149.6	35.75
3800-20MPT-340	190	3800	149.6	41.91
4200-20MPT-115	210	4200	165.4	15.67
4200-20MPT-170	210	4200	165.4	23.16
4200-20MPT-230	210	4200	165.4	31.33
4200-20MPT-290	210	4200	165.4	39.51
4200-20MPT-340	210	4200	165.4	46.32
4600-20MPT-115	230	4600	181.1	17.16
4600-20MPT-170	230	4600	181.1	25.37
4600-20MPT-230	230	4600	181.1	34.32
4600-20MPT-290	230	4600	181.1	43.27
4600-20MPT-340	230	4600	181.1	50.73

Panther® Sleeves



- Full factory width sleeves
- Sleeve edges are trimmed before shipment
- Sleeves cannot be accepted for return

Timken maintains inventory of most synchronous sleeve sizes. Contact customer service for availability. Minimum order quantity and/or lead times may apply.

Occasional production inconsistencies which may render a portion of the sleeve unusable can be present as a normal part of the production process.

Each sleeve is inspected to ensure that it contains 90% or more usable product. A full width sleeve with less than 10% unusable product is considered acceptable.

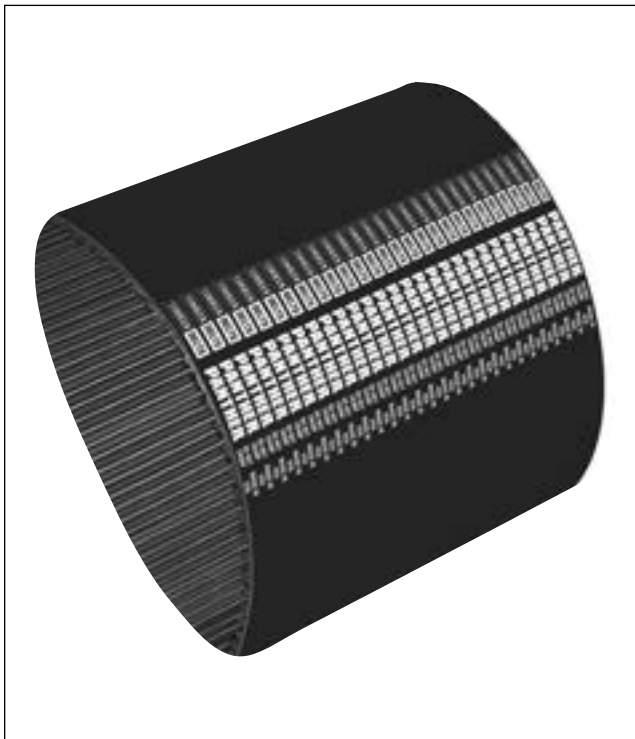

Panther® Sleeve Part Numbers

Part Number	Sleeve Width (mm)	Sleeve Weight (lbs)
8M Pitch – High Torque Synchronous (HTS) Sprockets: MPB, QD, Taper Bushed (8mm)		
480-8MPT-470SL	470	2.7
560-8MPT-470SL	470	3.2
600-8MPT-470SL	470	3.4
640-8MPT-470SL	470	3.6
720-8MPT-470SL	470	4.1
800-8MPT-470SL	470	4.5
880-8MPT-470SL	470	5.0
896-8MPT-470SL	470	5.1
920-8MPT-470SL	470	5.2
960-8MPT-470SL	470	5.4
1000-8MPT-470SL	470	5.7
1040-8MPT-470SL	470	5.9
1120-8MPT-470SL	470	6.4
1152-8MPT-470SL	470	6.5
1200-8MPT-470SL	470	6.8
1224-8MPT-470SL	470	6.9
1248-8MPT-470SL	470	7.1
1280-8MPT-470SL	470	7.3
1360-8MPT-470SL	470	7.7
1400-8MPT-470SL	470	7.9
1440-8MPT-470SL	470	8.2
1600-8MPT-470SL	470	9.1
1760-8MPT-470SL	470	10.0
1800-8MPT-470SL	470	10.2
1904-8MPT-470SL	470	10.8
2000-8MPT-470SL	470	11.3
2104-8MPT-470SL	470	11.9
2200-8MPT-470SL	470	12.5
2240-8MPT-470SL	470	12.7
2400-8MPT-470SL	470	13.6
2600-8MPT-470SL	470	14.7
2800-8MPT-470SL	470	15.9
3048-8MPT-470SL	470	17.3

Part Number Example: **1400-8MPT-470SL** = **1400** - **8M** **PT** - **470** **SL**
Pitch Length (millimeters) Tooth Pitch Panther Construction (RPP tooth profile) Width (millimeters) Sleeve

Part Number	Sleeve Width (mm)	Sleeve Weight (lbs)
8M Pitch – High Torque Synchronous (HTS) Sprockets: MPB, QD, Taper Bushed (8mm)		
3280-8MPT-470SL	470	18.6
3600-8MPT-470SL	470	20.4
4400-8MPT-470SL	470	24.9
14M Pitch – High Torque Synchronous (HTS) Sprockets: MPB, QD, Taper Bushed (14mm)		
966-14MPT-470SL	470	9.1
1092-14MPT-470SL	470	10.3
1190-14MPT-470SL	470	11.2
1400-14MPT-470SL	470	13.2
1610-14MPT-470SL	470	15.2
1750-14MPT-470SL	470	16.5
1764-14MPT-470SL	470	16.6
1778-14MPT-470SL	470	16.7
1792-14MPT-470SL	470	16.9
1820-14MPT-470SL	470	17.1
1848-14MPT-470SL	470	17.4
1862-14MPT-470SL	470	17.5
1890-14MPT-470SL	470	17.8
1904-14MPT-470SL	470	17.9
1960-14MPT-470SL	470	18.5
2100-14MPT-470SL	470	19.8
2310-14MPT-470SL	470	21.8
2450-14MPT-470SL	470	23.1
2590-14MPT-470SL	470	24.4
2800-14MPT-470SL	470	26.4
3150-14MPT-470SL	470	29.7
3360-14MPT-470SL	470	31.6
3500-14MPT-470SL	470	33.0
3850-14MPT-470SL	470	36.3
4326-14MPT-470SL	470	40.7
4578-14MPT-470SL	470	43.1
4956-14MPT-540SL	540	46.7

Part Number	Sleeve Width (mm)	Sleeve Weight (lbs)
20M Pitch – High Torque Synchronous (HTS) Sprockets: MPB, QD, Taper Bushed (20mm)		
2000-20MPT-570SL	570	30.5
2500-20MPT-570SL	570	38.1
3400-20MPT-570SL	570	51.8
3800-20MPT-570SL	570	57.9
4200-20MPT-570SL	570	64.0
4600-20MPT-570SL	570	70.1

Synchro-Cog[®] HT

Synchronous Drive Belt



Synchro-Cog® HT

Synchronous Drive Belt

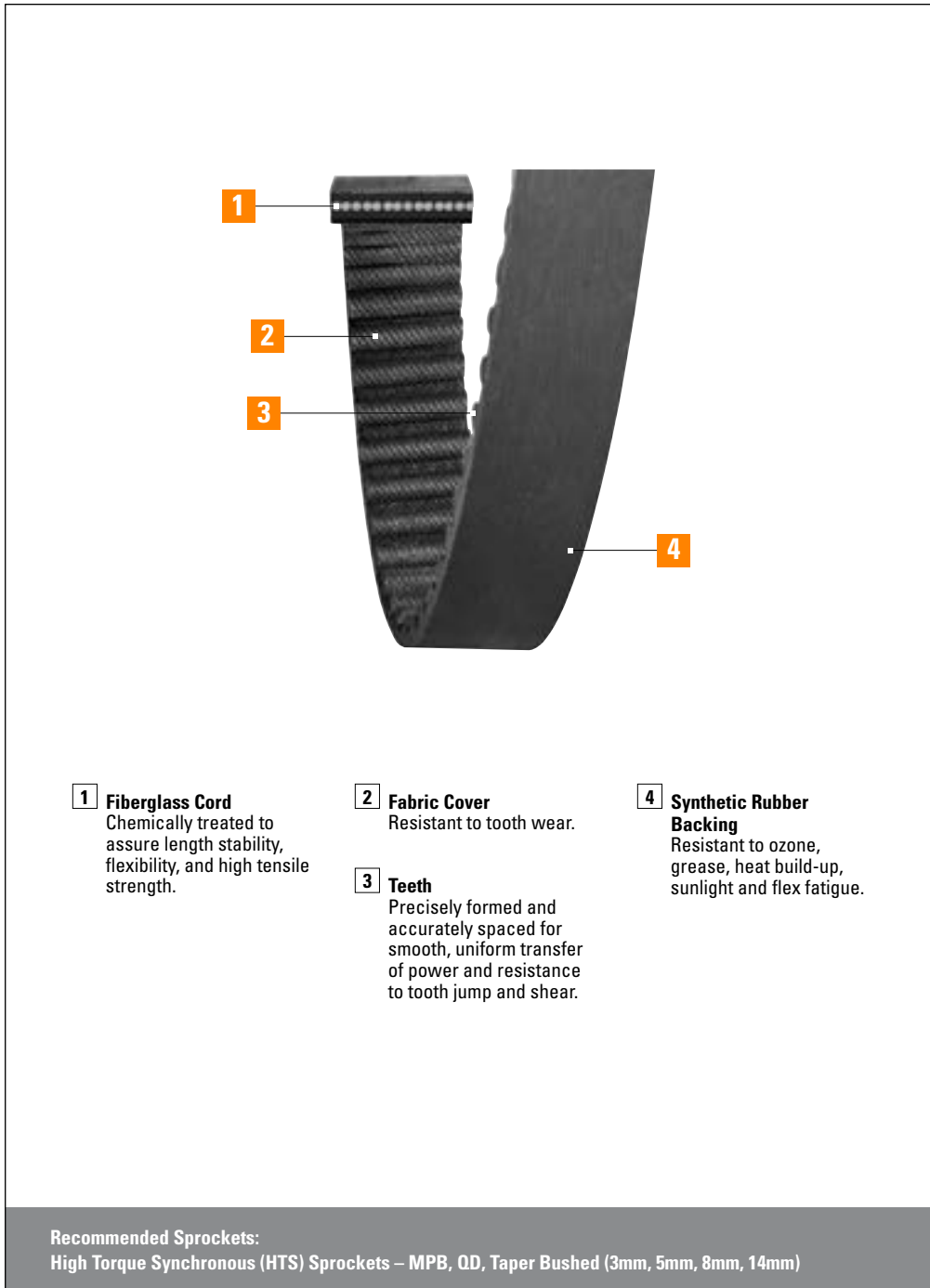

Medium torque capacity

Economical

Small, more compact drive packages

Maximum drive efficiency

HTD® tooth profile

Applications:

Blowers

Mixers

Machine tools

Sewing machines

Food processing

Paper processing

& More

Synchro-Cog® HT

Synchronous Drive Belt

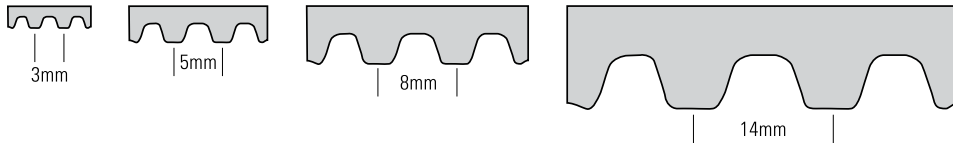

Synchro-Cog® HT delivers trouble-free power transmission with a smooth and quiet drive system.



Synchro-Cog® HT is a curvilinear synchronous belt with an HTD® profile. Although HT stands for high torque, the evolution of synchronous belts means Synchro-Cog HT is now more suitable for medium torque applications. Panther belts should be used for high torque and Panther XT for extreme torque applications.

Available in 3M, 5M, 8M and 14M cross sections in a wide variety of sizes, Synchro-Cog HT provides trouble free power transmission with a smooth and quiet drive system.

Synchro-Cog HT belts are made using fiberglass cord that is treated to assure length stability, flexibility, and high tensile strength. The rubber teeth are precisely formed and accurately spaced for smooth, uniform transfer of power.

A specially formulated rubber backing resists ozone, grease, heat build-up, sunlight and flex fatigue. The nylon fabric tooth cover is resistant to wear.

Synchro-Cog HT belts are compatible with RPP®, PowerGrip GT2® and HTD® sprockets.

PowerGrip GT2 and HTD are registered trademark of Gates Corporation

Synchro-Cog® HT

Synchronous Drive Belt

Synchro-Cog® HT Part Numbers

Part Number Example: **144-3M-15** = **144** - **3M** - **15**
Pitch Length (millimeters) Tooth Pitch (HTD profile) Width (millimeters)

Part Number	Number Of Teeth	Pitch Length		Weight (lbs)
		(mm)	(in)	
3M Pitch – High Torque Synchronous (HTS) Sprockets: MPB, QD, Taper Bushed (3mm)				
144-3M-6	48	144	5.7	0.01
144-3M-9	48	144	5.7	0.01
144-3M-15	48	144	5.7	0.01
150-3M-6	50	150	5.9	0.00
150-3M-9	50	150	5.9	0.01
150-3M-15	50	150	5.9	0.01
159-3M-6	53	159	6.3	0.01
159-3M-9	53	159	6.3	0.01
159-3M-15	53	159	6.3	0.01
168-3M-6	56	168	6.6	0.01
168-3M-9	56	168	6.6	0.01
168-3M-15	56	168	6.6	0.01
177-3M-6	59	177	7.0	0.01
177-3M-9	59	177	7.0	0.01
177-3M-15	59	177	7.0	0.01
180-3M-6	60	180	7.1	0.01
180-3M-9	60	180	7.1	0.01
180-3M-15	60	180	7.1	0.01
186-3M-6	62	186	7.3	0.01
186-3M-9	62	186	7.3	0.01
186-3M-15	62	186	7.3	0.02
189-3M-6	63	189	7.4	0.01
189-3M-9	63	189	7.4	0.01
189-3M-15	63	189	7.4	0.02
192-3M-6	64	192	7.6	0.01
192-3M-9	64	192	7.6	0.01
192-3M-15	64	192	7.6	0.02
201-3M-6	67	201	7.9	0.01
201-3M-9	67	201	7.9	0.01
201-3M-15	67	201	7.9	0.02
207-3M-6	69	207	8.1	0.01
207-3M-9	69	207	8.1	0.01
207-3M-15	69	207	8.1	0.02

Part Number	Number Of Teeth	Pitch Length		Weight (lbs)
		(mm)	(in)	
3M Pitch – High Torque Synchronous (HTS) Sprockets: MPB, QD, Taper Bushed (3mm)				
210-3M-6	70	210	8.3	0.01
210-3M-9	70	210	8.3	0.01
210-3M-15	70	210	8.3	0.02
213-3M-6	71	213	8.4	0.01
213-3M-9	71	213	8.4	0.01
213-3M-15	71	213	8.4	0.02
222-3M-6	74	222	8.7	0.01
222-3M-9	74	222	8.7	0.01
222-3M-15	74	222	8.7	0.02
225-3M-6	75	225	8.9	0.01
225-3M-9	75	225	8.9	0.01
225-3M-15	75	225	8.9	0.02
228-3M-6	76	228	9.0	0.01
228-3M-9	76	228	9.0	0.01
228-3M-15	76	228	9.0	0.02
234-3M-6	78	234	9.2	0.01
234-3M-9	78	234	9.2	0.01
234-3M-15	78	234	9.2	0.02
240-3M-6	80	240	9.4	0.01
240-3M-9	80	240	9.4	0.01
240-3M-15	80	240	9.4	0.02
252-3M-6	84	252	9.9	0.01
252-3M-9	84	252	9.9	0.01
252-3M-15	84	252	9.9	0.02
255-3M-6	85	255	10.0	0.01
255-3M-9	85	255	10.0	0.01
255-3M-15	85	255	10.0	0.02
264-3M-6	88	264	10.4	0.01
264-3M-9	88	264	10.4	0.01
264-3M-15	88	264	10.4	0.02
267-3M-6	89	267	10.5	0.01
267-3M-9	89	267	10.5	0.01
267-3M-15	89	267	10.5	0.02

Synchro-Cog® HT

Synchronous Drive Belt

Synchro-Cog® HT

Part Numbers

Part Number	Number Of Teeth	Pitch Length		Weight (lbs)
		(mm)	(in)	
3M Pitch – High Torque Synchronous (HTS) Sprockets: MPB, QD, Taper Bushed (3mm)				
276-3M-6	92	276	10.9	0.01
276-3M-9	92	276	10.9	0.01
276-3M-15	92	276	10.9	0.02
285-3M-6	95	285	11.2	0.01
285-3M-9	95	285	11.2	0.01
285-3M-15	95	285	11.2	0.02
300-3M-6	100	300	11.8	0.01
300-3M-9	100	300	11.8	0.01
300-3M-15	100	300	11.8	0.02
312-3M-6	104	312	12.3	0.01
312-3M-9	104	312	12.3	0.02
312-3M-15	104	312	12.3	0.03
318-3M-6	106	318	12.5	0.01
318-3M-9	106	318	12.5	0.02
318-3M-15	106	318	12.5	0.03
324-3M-6	108	324	12.8	0.01
324-3M-9	108	324	12.8	0.02
324-3M-15	108	324	12.8	0.03
330-3M-6	110	330	13.0	0.01
330-3M-9	110	330	13.0	0.02
330-3M-15	110	330	13.0	0.03
339-3M-6	113	339	13.3	0.01
339-3M-9	113	339	13.3	0.02
339-3M-15	113	339	13.3	0.03
357-3M-6	119	357	14.1	0.01
357-3M-9	119	357	14.1	0.02
357-3M-15	119	357	14.1	0.03
360-3M-6	120	360	14.2	0.01
360-3M-9	120	360	14.2	0.02
360-3M-15	120	360	14.2	0.03
363-3M-6	121	363	14.3	0.01
363-3M-9	121	363	14.3	0.02
363-3M-15	121	363	14.3	0.03

Part Number	Number Of Teeth	Pitch Length		Weight (lbs)
		(mm)	(in)	
3M Pitch – High Torque Synchronous (HTS) Sprockets: MPB, QD, Taper Bushed (3mm)				
375-3M-6	125	375	14.8	0.01
375-3M-9	125	375	14.8	0.02
375-3M-15	125	375	14.8	0.03
384-3M-6	128	384	15.1	0.01
384-3M-9	128	384	15.1	0.02
384-3M-15	128	384	15.1	0.03
390-3M-6	130	390	15.4	0.01
390-3M-9	130	390	15.4	0.02
390-3M-15	130	390	15.4	0.03
405-3M-6	135	405	15.9	0.01
405-3M-9	135	405	15.9	0.02
405-3M-15	135	405	15.9	0.03
420-3M-6	140	420	16.5	0.01
420-3M-9	140	420	16.5	0.02
420-3M-15	140	420	16.5	0.03
447-3M-6	149	447	17.6	0.01
447-3M-9	149	447	17.6	0.02
447-3M-15	149	447	17.6	0.04
456-3M-6	152	456	18.0	0.01
456-3M-9	152	456	18.0	0.02
456-3M-15	152	456	18.0	0.04
474-3M-6	158	474	18.7	0.02
474-3M-9	158	474	18.7	0.02
474-3M-15	158	474	18.7	0.04
483-3M-6	161	483	19.0	0.02
483-3M-9	161	483	19.0	0.02
483-3M-15	161	483	19.0	0.04
495-3M-6	165	495	19.5	0.02
495-3M-9	165	495	19.5	0.02
495-3M-15	165	495	19.5	0.04
501-3M-6	167	501	19.7	0.02
501-3M-9	167	501	19.7	0.02
501-3M-15	167	501	19.7	0.04

Synchro-Cog® HT

Synchronous Drive Belt

Part Number Example: **180-5M-25** = **180** - **5M** - **25**
Pitch Length (millimeters) Tooth Pitch (HTD profile) Width (millimeters)

Part Number	Number Of Teeth	Pitch Length		Weight (lbs)
		(mm)	(in)	
3M Pitch – High Torque Synchronous (HTS) Sprockets: MPB, QD, Taper Bushed (3mm)				
513-3M-6	171	513	20.2	0.02
513-3M-9	171	513	20.2	0.02
513-3M-15	171	513	20.2	0.04
522-3M-6	174	522	20.6	0.02
522-3M-9	174	522	20.6	0.03
522-3M-15	174	522	20.6	0.04
531-3M-6	177	531	20.9	0.02
531-3M-9	177	531	20.9	0.03
531-3M-15	177	531	20.9	0.04
564-3M-6	188	564	22.2	0.02
564-3M-9	188	564	22.2	0.03
564-3M-15	188	564	22.2	0.05
570-3M-6	190	570	22.4	0.02
570-3M-9	190	570	22.4	0.03
570-3M-15	190	570	22.4	0.05
582-3M-6	194	582	22.9	0.02
582-3M-9	194	582	22.9	0.03
582-3M-15	194	582	22.9	0.05
600-3M-6	200	600	23.6	0.02
600-3M-9	200	600	23.6	0.03
600-3M-15	200	600	23.6	0.05
633-3M-6	211	633	24.9	0.02
633-3M-9	211	633	24.9	0.03
633-3M-15	211	633	24.9	0.05
669-3M-6	223	669	26.3	0.02
669-3M-9	223	669	26.3	0.03
669-3M-15	223	669	26.3	0.05
711-3M-6	237	711	28.0	0.02
711-3M-9	237	711	28.0	0.03
711-3M-15	237	711	28.0	0.06
735-3M-6	245	735	28.9	0.02
735-3M-9	245	735	28.9	0.04
735-3M-15	245	735	28.9	0.06

Part Number	Number Of Teeth	Pitch Length		Weight (lbs)
		(mm)	(in)	
3M Pitch – High Torque Synchronous (HTS) Sprockets: MPB, QD, Taper Bushed (3mm)				
750-3M-6	250	750	29.5	0.02
750-3M-9	250	750	29.5	0.04
750-3M-15	250	750	29.5	0.06
804-3M-6	268	804	31.7	0.03
804-3M-9	268	804	31.7	0.04
804-3M-15	268	804	31.7	0.07
1026-3M-6	342	1026	40.4	0.03
1026-3M-9	342	1026	40.4	0.05
1026-3M-15	342	1026	40.4	0.08
1401-3M-6	467	1401	55.2	0.05
1401-3M-9	467	1401	55.2	0.07
1401-3M-15	467	1401	55.2	0.11
5M Pitch – High Torque Synchronous (HTS) Sprockets: MPB, QD, Taper Bushed (5mm)				
180-5M-9	36	180	7.1	0.01
180-5M-15	36	180	7.1	0.02
180-5M-25	36	180	7.1	0.04
200-5M-9	40	200	7.9	0.02
200-5M-15	40	200	7.9	0.03
200-5M-25	40	200	7.9	0.04
210-5M-9	42	210	8.3	0.02
210-5M-15	42	210	8.3	0.03
210-5M-25	42	210	8.3	0.05
215-5M-9	43	215	8.5	0.02
215-5M-15	43	215	8.5	0.03
215-5M-25	43	215	8.5	0.05
225-5M-9	45	225	8.9	0.02
225-5M-15	45	225	8.9	0.03
225-5M-25	45	225	8.9	0.05
230-5M-9	46	230	9.1	0.02
230-5M-15	46	230	9.1	0.03
230-5M-25	46	230	9.1	0.05
235-5M-9	47	235	9.3	0.02

Synchro-Cog® HT

Synchronous Drive Belt

Synchro-Cog® HT

Part Numbers

Part Number	Number Of Teeth	Pitch Length		Weight (lbs)
		(mm)	(in)	
5M Pitch – High Torque Synchronous (HTS) Sprockets: MPB, QD, Taper Bushed (5mm)				
235-5M-15	47	235	9.3	0.03
235-5M-25	47	235	9.3	0.05
245-5M-9	49	245	9.6	0.02
245-5M-15	49	245	9.6	0.03
245-5M-25	49	245	9.6	0.05
250-5M-9	50	250	9.8	0.02
250-5M-15	50	250	9.8	0.03
250-5M-25	50	250	9.8	0.06
255-5M-9	51	255	10.0	0.02
255-5M-15	51	255	10.0	0.03
255-5M-25	51	255	10.0	0.06
260-5M-9	52	260	10.2	0.02
260-5M-15	52	260	10.2	0.03
260-5M-25	52	260	10.2	0.06
265-5M-9	53	265	10.4	0.02
265-5M-15	53	265	10.4	0.04
265-5M-25	53	265	10.4	0.06
270-5M-9	54	270	10.6	0.02
270-5M-15	54	270	10.6	0.04
270-5M-25	54	270	10.6	0.06
275-5M-9	55	275	10.8	0.02
275-5M-15	55	275	10.8	0.04
275-5M-25	55	275	10.8	0.06
280-5M-9	56	280	11.0	0.02
280-5M-15	56	280	11.0	0.04
280-5M-25	56	280	11.0	0.06
285-5M-9	57	285	11.2	0.02
285-5M-15	57	285	11.2	0.04
285-5M-25	57	285	11.2	0.06
290-5M-9	58	290	11.4	0.02
290-5M-15	58	290	11.4	0.04
290-5M-25	58	290	11.4	0.06
295-5M-9	59	295	11.6	0.02

Part Number	Number Of Teeth	Pitch Length		Weight (lbs)
		(mm)	(in)	
5M Pitch – High Torque Synchronous (HTS) Sprockets: MPB, QD, Taper Bushed (5mm)				
295-5M-15	59	295	11.6	0.04
295-5M-25	59	295	11.6	0.07
300-5M-9	60	300	11.8	0.02
300-5M-15	60	300	11.8	0.04
300-5M-25	60	300	11.8	0.07
305-5M-9	61	305	12.0	0.02
305-5M-15	61	305	12.0	0.04
305-5M-25	61	305	12.0	0.07
310-5M-9	62	310	12.2	0.02
310-5M-15	62	310	12.2	0.04
310-5M-25	62	310	12.2	0.07
320-5M-9	64	320	12.6	0.03
320-5M-15	64	320	12.6	0.04
320-5M-25	64	320	12.6	0.07
325-5M-9	65	325	12.8	0.03
325-5M-15	65	325	12.8	0.04
325-5M-25	65	325	12.8	0.07
330-5M-9	66	330	13.0	0.03
330-5M-15	66	330	13.0	0.04
330-5M-25	66	330	13.0	0.07
340-5M-9	68	340	13.4	0.03
340-5M-15	68	340	13.4	0.05
340-5M-25	68	340	13.4	0.08
345-5M-9	69	345	13.6	0.03
345-5M-15	69	345	13.6	0.05
345-5M-25	69	345	13.6	0.08
350-5M-9	70	350	13.8	0.03
350-5M-15	70	350	13.8	0.05
350-5M-25	70	350	13.8	0.08
360-5M-9	72	360	14.2	0.03
360-5M-15	72	360	14.2	0.05
360-5M-25	72	360	14.2	0.08
365-5M-9	73	365	14.4	0.03

Synchro-Cog® HT

Synchronous Drive Belt

Part Number Example: **370-5M-15** = **370** - **5M** - **15**
Pitch Length (millimeters) Tooth Pitch (HTD profile) Width (millimeters)

Part Number	Number Of Teeth	Pitch Length		Weight (lbs)
		(mm)	(in)	
5M Pitch – High Torque Synchronous (HTS) Sprockets: MPB, QD, Taper Bushed (5mm)				
365-5M-15	73	365	14.4	0.05
365-5M-25	73	365	14.4	0.08
370-5M-9	74	370	14.6	0.03
370-5M-15	74	370	14.6	0.05
370-5M-25	74	370	14.6	0.08
375-5M-9	75	375	14.8	0.03
375-5M-15	75	375	14.8	0.05
375-5M-25	75	375	14.8	0.08
380-5M-9	76	380	15.0	0.03
380-5M-15	76	380	15.0	0.05
380-5M-25	76	380	15.0	0.08
385-5M-9	77	385	15.2	0.03
385-5M-15	77	385	15.2	0.05
385-5M-25	77	385	15.2	0.09
390-5M-9	78	390	15.4	0.03
390-5M-15	78	390	15.4	0.05
390-5M-25	78	390	15.4	0.09
395-5M-9	79	395	15.6	0.03
395-5M-15	79	395	15.6	0.05
395-5M-25	79	395	15.6	0.09
400-5M-9	80	400	15.7	0.03
400-5M-15	80	400	15.7	0.05
400-5M-25	80	400	15.7	0.09
405-5M-9	81	405	15.9	0.03
405-5M-15	81	405	15.9	0.05
405-5M-25	81	405	15.9	0.09
410-5M-9	82	410	16.1	0.03
410-5M-15	82	410	16.1	0.05
410-5M-25	82	410	16.1	0.09
420-5M-9	84	420	16.5	0.03
420-5M-15	84	420	16.5	0.06
420-5M-25	84	420	16.5	0.09
425-5M-9	85	425	16.7	0.03

Part Number	Number Of Teeth	Pitch Length		Weight (lbs)
		(mm)	(in)	
5M Pitch – High Torque Synchronous (HTS) Sprockets: MPB, QD, Taper Bushed (5mm)				
425-5M-15	85	425	16.7	0.06
425-5M-25	85	425	16.7	0.09
430-5M-9	86	430	16.9	0.03
430-5M-15	86	430	16.9	0.06
430-5M-25	86	430	16.9	0.10
435-5M-9	87	435	17.1	0.03
435-5M-15	87	435	17.1	0.06
435-5M-25	87	435	17.1	0.10
440-5M-9	88	440	17.3	0.04
440-5M-15	88	440	17.3	0.06
440-5M-25	88	440	17.3	0.10
445-5M-9	89	445	17.5	0.04
445-5M-15	89	445	17.5	0.06
445-5M-25	89	445	17.5	0.10
450-5M-9	90	450	17.7	0.04
450-5M-15	90	450	17.7	0.06
450-5M-25	90	450	17.7	0.10
460-5M-9	92	460	18.1	0.04
460-5M-15	92	460	18.1	0.06
460-5M-25	92	460	18.1	0.10
465-5M-9	93	465	18.3	0.04
465-5M-15	93	465	18.3	0.06
465-5M-25	93	465	18.3	0.10
470-5M-9	94	470	18.5	0.04
470-5M-15	94	470	18.5	0.06
470-5M-25	94	470	18.5	0.11
475-5M-9	95	475	18.7	0.04
475-5M-15	95	475	18.7	0.06
475-5M-25	95	475	18.7	0.11
480-5M-9	96	480	18.9	0.04
480-5M-15	96	480	18.9	0.06
480-5M-25	96	480	18.9	0.11
490-5M-9	98	490	19.3	0.04

Synchro-Cog® HT

Synchronous Drive Belt

Synchro-Cog® HT

Part Numbers

Part Number	Number Of Teeth	Pitch Length		Weight (lbs)
		(mm)	(in)	
5M Pitch – High Torque Synchronous (HTS) Sprockets: MPB, QD, Taper Bushed (5mm)				
490-5M-15	98	490	19.3	0.07
490-5M-25	98	490	19.3	0.11
500-5M-9	100	500	19.7	0.04
500-5M-15	100	500	19.7	0.07
500-5M-25	100	500	19.7	0.11
505-5M-9	101	505	19.9	0.04
505-5M-15	101	505	19.9	0.07
505-5M-25	101	505	19.9	0.11
510-5M-9	102	510	20.1	0.04
510-5M-15	102	510	20.1	0.07
510-5M-25	102	510	20.1	0.11
520-5M-9	104	520	20.5	0.04
520-5M-15	104	520	20.5	0.07
520-5M-25	104	520	20.5	0.12
525-5M-9	105	525	20.7	0.04
525-5M-15	105	525	20.7	0.07
525-5M-25	105	525	20.7	0.12
530-5M-9	106	530	20.9	0.04
530-5M-15	106	530	20.9	0.07
530-5M-25	106	530	20.9	0.12
535-5M-9	107	535	21.1	0.04
535-5M-15	107	535	21.1	0.07
535-5M-25	107	535	21.1	0.12
540-5M-9	108	540	21.3	0.04
540-5M-15	108	540	21.3	0.07
540-5M-25	108	540	21.3	0.12
550-5M-9	110	550	21.7	0.04
550-5M-15	110	550	21.7	0.07
550-5M-25	110	550	21.7	0.12
560-5M-9	112	560	22.0	0.05
560-5M-15	112	560	22.0	0.08
560-5M-25	112	560	22.0	0.13
565-5M-9	113	565	22.2	0.05

Part Number	Number Of Teeth	Pitch Length		Weight (lbs)
		(mm)	(in)	
5M Pitch – High Torque Synchronous (HTS) Sprockets: MPB, QD, Taper Bushed (5mm)				
565-5M-15	113	565	22.2	0.08
565-5M-25	113	565	22.2	0.13
570-5M-9	114	570	22.4	0.05
570-5M-15	114	570	22.4	0.08
570-5M-25	114	570	22.4	0.13
575-5M-9	115	575	22.6	0.05
575-5M-15	115	575	22.6	0.08
575-5M-25	115	575	22.6	0.13
580-5M-9	116	580	22.8	0.05
580-5M-15	116	580	22.8	0.08
580-5M-25	116	580	22.8	0.13
585-5M-9	117	585	23.0	0.05
585-5M-15	117	585	23.0	0.08
585-5M-25	117	585	23.0	0.13
590-5M-9	118	590	23.2	0.05
590-5M-15	118	590	23.2	0.08
590-5M-25	118	590	23.2	0.13
600-5M-9	120	600	23.6	0.05
600-5M-15	120	600	23.6	0.08
600-5M-25	120	600	23.6	0.13
605-5M-9	121	605	23.8	0.05
605-5M-15	121	605	23.8	0.08
605-5M-25	121	605	23.8	0.14
610-5M-9	122	610	24.0	0.05
610-5M-15	122	610	24.0	0.08
610-5M-25	122	610	24.0	0.14
615-5M-9	123	615	24.2	0.05
615-5M-15	123	615	24.2	0.08
615-5M-25	123	615	24.2	0.14
620-5M-9	124	620	24.4	0.05
620-5M-15	124	620	24.4	0.08
620-5M-25	124	620	24.4	0.14
625-5M-9	125	625	24.6	0.05

Synchro-Cog® HT

Synchronous Drive Belt

Part Number Example: **700-5M-15** = **700** - **5M** - **15**
Pitch Length (millimeters) Tooth Pitch (HTD profile) Width (millimeters)

Part Number	Number Of Teeth	Pitch Length		Weight (lbs)
		(mm)	(in)	
5M Pitch – High Torque Synchronous (HTS) Sprockets: MPB, QD, Taper Bushed (5mm)				
625-5M-15	125	625	24.6	0.08
625-5M-25	125	625	24.6	0.14
635-5M-9	127	635	25.0	0.05
635-5M-15	127	635	25.0	0.09
635-5M-25	127	635	25.0	0.14
640-5M-9	128	640	25.2	0.05
640-5M-15	128	640	25.2	0.09
640-5M-25	128	640	25.2	0.14
645-5M-9	129	645	25.4	0.05
645-5M-15	129	645	25.4	0.09
645-5M-25	129	645	25.4	0.14
650-5M-9	130	650	25.6	0.05
650-5M-15	130	650	25.6	0.09
650-5M-25	130	650	25.6	0.15
655-5M-9	131	655	25.8	0.05
655-5M-15	131	655	25.8	0.09
655-5M-25	131	655	25.8	0.15
665-5M-9	133	665	26.2	0.05
665-5M-15	133	665	26.2	0.09
665-5M-25	133	665	26.2	0.15
670-5M-9	134	670	26.4	0.05
670-5M-15	134	670	26.4	0.09
670-5M-25	134	670	26.4	0.15
675-5M-9	135	675	26.6	0.05
675-5M-15	135	675	26.6	0.09
675-5M-25	135	675	26.6	0.15
685-5M-9	137	685	27.0	0.06
685-5M-15	137	685	27.0	0.09
685-5M-25	137	685	27.0	0.15
690-5M-9	138	690	27.2	0.06
690-5M-15	138	690	27.2	0.09
690-5M-25	138	690	27.2	0.15
695-5M-9	139	695	27.4	0.06

Part Number	Number Of Teeth	Pitch Length		Weight (lbs)
		(mm)	(in)	
5M Pitch – High Torque Synchronous (HTS) Sprockets: MPB, QD, Taper Bushed (5mm)				
695-5M-15	139	695	27.4	0.09
695-5M-25	139	695	27.4	0.16
700-5M-9	140	700	27.6	0.06
700-5M-15	140	700	27.6	0.09
700-5M-25	140	700	27.6	0.16
710-5M-9	142	710	28.0	0.06
710-5M-15	142	710	28.0	0.10
710-5M-25	142	710	28.0	0.16
720-5M-9	144	720	28.3	0.06
720-5M-15	144	720	28.3	0.10
720-5M-25	144	720	28.3	0.16
725-5M-9	145	725	28.5	0.06
725-5M-15	145	725	28.5	0.10
725-5M-25	145	725	28.5	0.16
740-5M-9	148	740	29.1	0.06
740-5M-15	148	740	29.1	0.10
740-5M-25	148	740	29.1	0.17
750-5M-9	150	750	29.5	0.06
750-5M-15	150	750	29.5	0.10
750-5M-25	150	750	29.5	0.17
755-5M-9	151	755	29.7	0.06
755-5M-15	151	755	29.7	0.10
755-5M-25	151	755	29.7	0.17
770-5M-9	154	770	30.3	0.06
770-5M-15	154	770	30.3	0.10
770-5M-25	154	770	30.3	0.17
775-5M-9	155	775	30.5	0.06
775-5M-15	155	775	30.5	0.10
775-5M-25	155	775	30.5	0.17
780-5M-9	156	780	30.7	0.06
780-5M-15	156	780	30.7	0.10
780-5M-25	156	780	30.7	0.17
790-5M-9	158	790	31.1	0.06

Synchro-Cog® HT

Synchronous Drive Belt

Synchro-Cog® HT

Part Numbers

Part Number	Number Of Teeth	Pitch Length		Weight (lbs)
		(mm)	(in)	
5M Pitch – High Torque Synchronous (HTS) Sprockets: MPB, QD, Taper Bushed (5mm)				
790-5M-15	158	790	31.1	0.11
790-5M-25	158	790	31.1	0.18
800-5M-9	160	800	31.5	0.06
800-5M-15	160	800	31.5	0.11
800-5M-25	160	800	31.5	0.18
810-5M-9	162	810	31.9	0.06
810-5M-15	162	810	31.9	0.11
810-5M-25	162	810	31.9	0.18
825-5M-9	165	825	32.5	0.07
825-5M-15	165	825	32.5	0.11
825-5M-25	165	825	32.5	0.18
835-5M-9	167	835	32.9	0.07
835-5M-15	167	835	32.9	0.11
835-5M-25	167	835	32.9	0.19
850-5M-9	170	850	33.5	0.07
850-5M-15	170	850	33.5	0.11
850-5M-25	170	850	33.5	0.19
860-5M-9	172	860	33.9	0.07
860-5M-15	172	860	33.9	0.12
860-5M-25	172	860	33.9	0.19
870-5M-9	174	870	34.3	0.07
870-5M-15	174	870	34.3	0.12
870-5M-25	174	870	34.3	0.19
890-5M-9	178	890	35.0	0.07
890-5M-15	178	890	35.0	0.12
890-5M-25	178	890	35.0	0.20
900-5M-9	180	900	35.4	0.07
900-5M-15	180	900	35.4	0.12
900-5M-25	180	900	35.4	0.20
920-5M-9	184	920	36.2	0.07
920-5M-15	184	920	36.2	0.12
920-5M-25	184	920	36.2	0.21
925-5M-9	185	925	36.4	0.07

Part Number	Number Of Teeth	Pitch Length		Weight (lbs)
		(mm)	(in)	
5M Pitch – High Torque Synchronous (HTS) Sprockets: MPB, QD, Taper Bushed (5mm)				
925-5M-15	185	925	36.4	0.12
925-5M-25	185	925	36.4	0.21
935-5M-9	187	935	36.8	0.08
935-5M-15	187	935	36.8	0.13
935-5M-25	187	935	36.8	0.21
940-5M-9	188	940	37.0	0.08
940-5M-15	188	940	37.0	0.13
940-5M-25	188	940	37.0	0.21
950-5M-9	190	950	37.4	0.08
950-5M-15	190	950	37.4	0.13
950-5M-25	190	950	37.4	0.21
960-5M-9	192	960	37.8	0.08
960-5M-15	192	960	37.8	0.13
960-5M-25	192	960	37.8	0.21
965-5M-9	193	965	38.0	0.08
965-5M-15	193	965	38.0	0.13
965-5M-25	193	965	38.0	0.22
975-5M-9	195	975	38.4	0.08
975-5M-15	195	975	38.4	0.13
975-5M-25	195	975	38.4	0.22
980-5M-9	196	980	38.6	0.08
980-5M-15	196	980	38.6	0.13
980-5M-25	196	980	38.6	0.22
1000-5M-9	200	1000	39.4	0.08
1000-5M-15	200	1000	39.4	0.13
1000-5M-25	200	1000	39.4	0.22
1025-5M-9	205	1025	40.4	0.08
1025-5M-15	205	1025	40.4	0.14
1025-5M-25	205	1025	40.4	0.23
1050-5M-9	210	1050	41.3	0.08
1050-5M-15	210	1050	41.3	0.14
1050-5M-25	210	1050	41.3	0.23
1100-5M-9	220	1100	43.3	0.09

Synchro-Cog® HT

Synchronous Drive Belt

Part Number Example: **1300-5M-25** = **1300** - **5M** - **25**
Pitch Length (millimeters) Tooth Pitch (HTD profile) Width (millimeters)

Part Number	Number Of Teeth	Pitch Length		Weight (lbs)
		(mm)	(in)	
5M Pitch – High Torque Synchronous (HTS) Sprockets: MPB, QD, Taper Bushed (5mm)				
1100-5M-15	220	1100	43.3	0.15
1100-5M-25	220	1100	43.3	0.25
1115-5M-9	223	1115	43.9	0.09
1115-5M-15	223	1115	43.9	0.15
1115-5M-25	223	1115	43.9	0.25
1125-5M-9	225	1125	44.3	0.09
1125-5M-15	225	1125	44.3	0.15
1125-5M-25	225	1125	44.3	0.25
1145-5M-9	229	1145	45.1	0.09
1145-5M-15	229	1145	45.1	0.15
1145-5M-25	229	1145	45.1	0.26
1175-5M-9	235	1175	46.3	0.09
1175-5M-15	235	1175	46.3	0.16
1175-5M-25	235	1175	46.3	0.26
1180-5M-9	236	1180	46.5	0.09
1180-5M-15	236	1180	46.5	0.16
1180-5M-25	236	1180	46.5	0.26
1195-5M-9	239	1195	47.0	0.10
1195-5M-15	239	1195	47.0	0.16
1195-5M-25	239	1195	47.0	0.27
1200-5M-9	240	1200	47.2	0.10
1200-5M-15	240	1200	47.2	0.16
1200-5M-25	240	1200	47.2	0.27
1210-5M-9	242	1210	47.6	0.10
1210-5M-15	242	1210	47.6	0.16
1210-5M-25	242	1210	47.6	0.27
1250-5M-9	250	1250	49.2	0.10
1250-5M-15	250	1250	49.2	0.17
1250-5M-25	250	1250	49.2	0.28
1270-5M-9	254	1270	50.0	0.10
1270-5M-15	254	1270	50.0	0.17
1270-5M-25	254	1270	50.0	0.28
1290-5M-9	258	1290	50.8	0.10

Part Number	Number Of Teeth	Pitch Length		Weight (lbs)
		(mm)	(in)	
5M Pitch – High Torque Synchronous (HTS) Sprockets: MPB, QD, Taper Bushed (5mm)				
1290-5M-15	258	1290	50.8	0.17
1290-5M-25	258	1290	50.8	0.29
1295-5M-9	259	1295	51.0	0.10
1295-5M-15	259	1295	51.0	0.17
1295-5M-25	259	1295	51.0	0.29
1300-5M-9	260	1300	51.2	0.10
1300-5M-15	260	1300	51.2	0.17
1300-5M-25	260	1300	51.2	0.29
1340-5M-9	268	1340	52.8	0.11
1340-5M-15	268	1340	52.8	0.18
1340-5M-25	268	1340	52.8	0.30
1350-5M-9	270	1350	53.1	0.11
1350-5M-15	270	1350	53.1	0.18
1350-5M-25	270	1350	53.1	0.30
1375-5M-9	275	1375	54.1	0.11
1375-5M-15	275	1375	54.1	0.18
1375-5M-25	275	1375	54.1	0.31
1420-5M-9	284	1420	55.9	0.11
1420-5M-15	284	1420	55.9	0.19
1420-5M-25	284	1420	55.9	0.32
1450-5M-9	290	1450	57.1	0.12
1450-5M-15	290	1450	57.1	0.19
1450-5M-25	290	1450	57.1	0.32
1500-5M-9	300	1500	59.1	0.12
1500-5M-15	300	1500	59.1	0.20
1500-5M-25	300	1500	59.1	0.34
1595-5M-9	319	1595	62.8	0.13
1595-5M-15	319	1595	62.8	0.21
1595-5M-25	319	1595	62.8	0.36
1600-5M-9	320	1600	63.0	0.13
1600-5M-15	320	1600	63.0	0.21
1600-5M-25	320	1600	63.0	0.36
1685-5M-9	337	1685	66.3	0.14

Synchro-Cog® HT

Synchronous Drive Belt

Synchro-Cog® HT

Part Numbers

Part Number	Number Of Teeth	Pitch Length		Weight (lbs)
		(mm)	(in)	
5M Pitch – High Torque Synchronous (HTS) Sprockets: MPB, QD, Taper Bushed (5mm)				
1685-5M-15	337	1685	66.3	0.23
1685-5M-25	337	1685	66.3	0.38
1690-5M-9	338	1690	66.5	0.14
1690-5M-15	338	1690	66.5	0.23
1690-5M-25	338	1690	66.5	0.38
1790-5M-9	358	1790	70.5	0.14
1790-5M-15	358	1790	70.5	0.24
1790-5M-25	358	1790	70.5	0.40
1800-5M-9	360	1800	70.9	0.14
1800-5M-15	360	1800	70.9	0.24
1800-5M-25	360	1800	70.9	0.40
1895-5M-9	379	1895	74.6	0.15
1895-5M-15	379	1895	74.6	0.25
1895-5M-25	379	1895	74.6	0.42
2000-5M-9	400	2000	78.7	0.16
2000-5M-15	400	2000	78.7	0.27
2000-5M-25	400	2000	78.7	0.45
2100-5M-9	420	2100	82.7	0.17
2100-5M-15	420	2100	82.7	0.28
2100-5M-25	420	2100	82.7	0.47
2350-5M-9	470	2350	92.5	0.19
2350-5M-15	470	2350	92.5	0.32
2350-5M-25	470	2350	92.5	0.53
2525-5M-9	505	2525	99.4	0.20
2525-5M-15	505	2525	99.4	0.34
2525-5M-25	505	2525	99.4	0.56
2635-5M-9	527	2635	103.7	0.21
2635-5M-15	527	2635	103.7	0.35
2635-5M-25	527	2635	103.7	0.59
4260-5M-9	852	4260	167.7	0.34
4260-5M-15	852	4260	167.7	0.57
4260-5M-25	852	4260	167.7	0.95
288-8M-20	36	288	11.3	0.07

Part Number	Number Of Teeth	Pitch Length		Weight (lbs)
		(mm)	(in)	
5M Pitch – High Torque Synchronous (HTS) Sprockets: MPB, QD, Taper Bushed (5mm)				
288-8M-30	36	288	11.3	0.11
288-8M-50	36	288	11.3	0.18
288-8M-85	36	288	11.3	0.32
8M Pitch – High Torque Synchronous (HTS) Sprockets: MPB, QD, Taper Bushed (8mm)				
320-8M-20	40	320	12.6	0.08
320-8M-30	40	320	12.6	0.12
320-8M-50	40	320	12.6	0.19
320-8M-85	40	320	12.6	0.33
368-8M-20	46	368	14.5	0.09
368-8M-30	46	368	14.5	0.13
368-8M-50	46	368	14.5	0.22
368-8M-85	46	368	14.5	0.38
400-8M-20	50	400	15.7	0.10
400-8M-30	50	400	15.7	0.14
400-8M-50	50	400	15.7	0.24
400-8M-85	50	400	15.7	0.41
408-8M-20	51	408	16.1	0.10
408-8M-30	51	408	16.1	0.15
408-8M-50	51	408	16.1	0.25
408-8M-85	51	408	16.1	0.42
424-8M-20	53	424	16.7	0.10
424-8M-30	53	424	16.7	0.15
424-8M-50	53	424	16.7	0.26
424-8M-85	53	424	16.7	0.44
440-8M-20	55	440	17.3	0.11
440-8M-30	55	440	17.3	0.16
440-8M-50	55	440	17.3	0.27
440-8M-85	55	440	17.3	0.45
448-8M-20	56	448	17.6	0.11
448-8M-30	56	448	17.6	0.16
448-8M-50	56	448	17.6	0.27
448-8M-85	56	448	17.6	0.46

Synchro-Cog® HT

Synchronous Drive Belt

Part Number Example: **600-8M-85** = **600** - **8M** - **85**
Pitch Length (millimeters) Tooth Pitch (HTD profile) Width (millimeters)

Part Number	Number Of Teeth	Pitch Length		Weight (lbs)
		(mm)	(in)	
8M Pitch – High Torque Synchronous (HTS) Sprockets: MPB, QD, Taper Bushed (8mm)				
480-8M-20	60	480	18.9	0.12
480-8M-30	60	480	18.9	0.17
480-8M-50	60	480	18.9	0.29
480-8M-85	60	480	18.9	0.49
512-8M-20	64	512	20.2	0.12
512-8M-30	64	512	20.2	0.19
512-8M-50	64	512	20.2	0.31
512-8M-85	64	512	20.2	0.53
520-8M-20	65	520	20.5	0.13
520-8M-30	65	520	20.5	0.19
520-8M-50	65	520	20.5	0.31
520-8M-85	65	520	20.5	0.53
536-8M-20	67	536	21.1	0.13
536-8M-30	67	536	21.1	0.19
536-8M-50	67	536	21.1	0.32
536-8M-85	67	536	21.1	0.55
544-8M-20	68	544	21.4	0.13
544-8M-30	68	544	21.4	0.20
544-8M-50	68	544	21.4	0.33
544-8M-85	68	544	21.4	0.56
560-8M-20	70	560	22.0	0.14
560-8M-30	70	560	22.0	0.20
560-8M-50	70	560	22.0	0.34
560-8M-85	70	560	22.0	0.57
568-8M-20	71	568	22.4	0.14
568-8M-30	71	568	22.4	0.21
568-8M-50	71	568	22.4	0.34
568-8M-85	71	568	22.4	0.58
576-8M-20	72	576	22.7	0.14
576-8M-30	72	576	22.7	0.21
576-8M-50	72	576	22.7	0.35
576-8M-85	72	576	22.7	0.59
584-8M-20	73	584	23.0	0.14

Part Number	Number Of Teeth	Pitch Length		Weight (lbs)
		(mm)	(in)	
8M Pitch – High Torque Synchronous (HTS) Sprockets: MPB, QD, Taper Bushed (8mm)				
584-8M-30	73	584	23.0	0.21
584-8M-50	73	584	23.0	0.35
584-8M-85	73	584	23.0	0.60
592-8M-20	74	592	23.3	0.14
592-8M-30	74	592	23.3	0.21
592-8M-50	74	592	23.3	0.36
592-8M-85	74	592	23.3	0.61
600-8M-20	75	600	23.6	0.14
600-8M-30	75	600	23.6	0.22
600-8M-50	75	600	23.6	0.36
600-8M-85	75	600	23.6	0.62
608-8M-20	76	608	23.9	0.15
608-8M-30	76	608	23.9	0.22
608-8M-50	76	608	23.9	0.37
608-8M-85	76	608	23.9	0.62
624-8M-20	78	624	24.6	0.15
624-8M-30	78	624	24.6	0.23
624-8M-50	78	624	24.6	0.38
624-8M-85	78	624	24.6	0.64
632-8M-20	79	632	24.9	0.15
632-8M-30	79	632	24.9	0.23
632-8M-50	79	632	24.9	0.38
632-8M-85	79	632	24.9	0.65
640-8M-20	80	640	25.2	0.15
640-8M-30	80	640	25.2	0.23
640-8M-50	80	640	25.2	0.39
640-8M-85	80	640	25.2	0.66
648-8M-20	81	648	25.5	0.16
648-8M-30	81	648	25.5	0.23
648-8M-50	81	648	25.5	0.39
648-8M-85	81	648	25.5	0.67
656-8M-20	82	656	25.8	0.16
656-8M-30	82	656	25.8	0.24

Synchro-Cog® HT

Synchronous Drive Belt

Synchro-Cog® HT

Part Numbers

Part Number	Number Of Teeth	Pitch Length		Weight (lbs)
		(mm)	(in)	
8M Pitch – High Torque Synchronous (HTS) Sprockets: MPB, QD, Taper Bushed (8mm)				
656-8M-50	82	656	25.8	0.40
656-8M-85	82	656	25.8	0.67
680-8M-20	85	680	26.8	0.16
680-8M-30	85	680	26.8	0.25
680-8M-50	85	680	26.8	0.41
680-8M-85	85	680	26.8	0.70
688-8M-20	86	688	27.1	0.17
688-8M-30	86	688	27.1	0.25
688-8M-50	86	688	27.1	0.42
688-8M-85	86	688	27.1	0.71
696-8M-20	87	696	27.4	0.17
696-8M-30	87	696	27.4	0.25
696-8M-50	87	696	27.4	0.42
696-8M-85	87	696	27.4	0.71
712-8M-20	89	712	28.0	0.17
712-8M-30	89	712	28.0	0.26
712-8M-50	89	712	28.0	0.43
712-8M-85	89	712	28.0	0.73
720-8M-20	90	720	28.3	0.17
720-8M-30	90	720	28.3	0.26
720-8M-50	90	720	28.3	0.43
720-8M-85	90	720	28.3	0.74
760-8M-20	95	760	29.9	0.18
760-8M-30	95	760	29.9	0.28
760-8M-50	95	760	29.9	0.46
760-8M-85	95	760	29.9	0.78
768-8M-20	96	768	30.2	0.19
768-8M-30	96	768	30.2	0.28
768-8M-50	96	768	30.2	0.46
768-8M-85	96	768	30.2	0.79
776-8M-20	97	776	30.6	0.19
776-8M-30	97	776	30.6	0.28
776-8M-50	97	776	30.6	0.47

Part Number	Number Of Teeth	Pitch Length		Weight (lbs)
		(mm)	(in)	
8M Pitch – High Torque Synchronous (HTS) Sprockets: MPB, QD, Taper Bushed (8mm)				
776-8M-85	97	776	30.6	0.80
784-8M-20	98	784	30.9	0.19
784-8M-30	98	784	30.9	0.28
784-8M-50	98	784	30.9	0.47
784-8M-85	98	784	30.9	0.80
792-8M-20	99	792	31.2	0.19
792-8M-30	99	792	31.2	0.29
792-8M-50	99	792	31.2	0.48
792-8M-85	99	792	31.2	0.81
800-8M-20	100	800	31.5	0.19
800-8M-30	100	800	31.5	0.29
800-8M-50	100	800	31.5	0.48
800-8M-85	100	800	31.5	0.82
816-8M-20	102	816	32.1	0.20
816-8M-30	102	816	32.1	0.30
816-8M-50	102	816	32.1	0.49
816-8M-85	102	816	32.1	0.84
824-8M-20	103	824	32.4	0.20
824-8M-30	103	824	32.4	0.30
824-8M-50	103	824	32.4	0.50
824-8M-85	103	824	32.4	0.85
840-8M-20	105	840	33.1	0.20
840-8M-30	105	840	33.1	0.30
840-8M-50	105	840	33.1	0.51
840-8M-85	105	840	33.1	0.86
848-8M-20	106	848	33.4	0.20
848-8M-30	106	848	33.4	0.31
848-8M-50	106	848	33.4	0.51
848-8M-85	106	848	33.4	0.87
856-8M-20	107	856	33.7	0.21
856-8M-30	107	856	33.7	0.31
856-8M-50	107	856	33.7	0.52
856-8M-85	107	856	33.7	0.88

Synchro-Cog® HT

Synchronous Drive Belt

Part Number Example: **1000-8M-50** = **1000** - **8M** - **50**
Pitch Length (millimeters) Tooth Pitch (HTD profile) Width (millimeters)

Part Number	Number Of Teeth	Pitch Length		Weight (lbs)
		(mm)	(in)	
8M Pitch – High Torque Synchronous (HTS) Sprockets: MPB, QD, Taper Bushed (8mm)				
864-8M-20	108	864	34.0	0.21
864-8M-30	108	864	34.0	0.31
864-8M-50	108	864	34.0	0.52
864-8M-85	108	864	34.0	0.89
880-8M-20	110	880	34.6	0.21
880-8M-30	110	880	34.6	0.32
880-8M-50	110	880	34.6	0.53
880-8M-85	110	880	34.6	0.90
896-8M-20	112	896	35.3	0.22
896-8M-30	112	896	35.3	0.32
896-8M-50	112	896	35.3	0.54
896-8M-85	112	896	35.3	0.92
912-8M-20	114	912	35.9	0.22
912-8M-30	114	912	35.9	0.33
912-8M-50	114	912	35.9	0.55
912-8M-85	114	912	35.9	0.94
920-8M-20	115	920	36.2	0.22
920-8M-30	115	920	36.2	0.33
920-8M-50	115	920	36.2	0.56
920-8M-85	115	920	36.2	0.94
928-8M-20	116	928	36.5	0.22
928-8M-30	116	928	36.5	0.34
928-8M-50	116	928	36.5	0.56
928-8M-85	116	928	36.5	0.95
936-8M-20	117	936	36.9	0.23
936-8M-30	117	936	36.9	0.34
936-8M-50	117	936	36.9	0.57
936-8M-85	117	936	36.9	0.96
944-8M-20	118	944	37.2	0.23
944-8M-30	118	944	37.2	0.34
944-8M-50	118	944	37.2	0.57
944-8M-85	118	944	37.2	0.97
952-8M-20	119	952	37.5	0.23

Part Number	Number Of Teeth	Pitch Length		Weight (lbs)
		(mm)	(in)	
8M Pitch – High Torque Synchronous (HTS) Sprockets: MPB, QD, Taper Bushed (8mm)				
952-8M-30	119	952	37.5	0.34
952-8M-50	119	952	37.5	0.57
952-8M-85	119	952	37.5	0.98
960-8M-20	120	960	37.8	0.23
960-8M-30	120	960	37.8	0.35
960-8M-50	120	960	37.8	0.58
960-8M-85	120	960	37.8	0.99
968-8M-20	121	968	38.1	0.23
968-8M-30	121	968	38.1	0.35
968-8M-50	121	968	38.1	0.58
968-8M-85	121	968	38.1	0.99
976-8M-20	122	976	38.4	0.24
976-8M-30	122	976	38.4	0.35
976-8M-50	122	976	38.4	0.59
976-8M-85	122	976	38.4	1.00
1000-8M-20	125	1000	39.4	0.24
1000-8M-30	125	1000	39.4	0.36
1000-8M-50	125	1000	39.4	0.60
1000-8M-85	125	1000	39.4	1.03
1016-8M-20	127	1016	40.0	0.25
1016-8M-30	127	1016	40.0	0.37
1016-8M-50	127	1016	40.0	0.61
1016-8M-85	127	1016	40.0	1.04
1024-8M-20	128	1024	40.3	0.25
1024-8M-30	128	1024	40.3	0.37
1024-8M-50	128	1024	40.3	0.62
1024-8M-85	128	1024	40.3	1.05
1040-8M-20	130	1040	40.9	0.25
1040-8M-30	130	1040	40.9	0.38
1040-8M-50	130	1040	40.9	0.63
1040-8M-85	130	1040	40.9	1.07
1056-8M-20	132	1056	41.6	0.26
1056-8M-30	132	1056	41.6	0.38

Synchro-Cog® HT

Synchronous Drive Belt

Synchro-Cog® HT

Part Numbers

Part Number	Number Of Teeth	Pitch Length		Weight (lbs)
		(mm)	(in)	
8M Pitch – High Torque Synchronous (HTS) Sprockets: MPB, QD, Taper Bushed (8mm)				
1056-8M-50	132	1056	41.6	0.64
1056-8M-85	132	1056	41.6	1.08
1064-8M-20	133	1064	41.9	0.26
1064-8M-30	133	1064	41.9	0.39
1064-8M-50	133	1064	41.9	0.64
1064-8M-85	133	1064	41.9	1.09
1080-8M-20	135	1080	42.5	0.26
1080-8M-30	135	1080	42.5	0.39
1080-8M-50	135	1080	42.5	0.65
1080-8M-85	135	1080	42.5	1.11
1104-8M-20	138	1104	43.5	0.27
1104-8M-30	138	1104	43.5	0.40
1104-8M-50	138	1104	43.5	0.67
1104-8M-85	138	1104	43.5	1.13
1120-8M-20	140	1120	44.1	0.27
1120-8M-30	140	1120	44.1	0.41
1120-8M-50	140	1120	44.1	0.68
1120-8M-85	140	1120	44.1	1.15
1128-8M-20	141	1128	44.4	0.27
1128-8M-30	141	1128	44.4	0.41
1128-8M-50	141	1128	44.4	0.68
1128-8M-85	141	1128	44.4	1.16
1136-8M-20	142	1136	44.7	0.27
1136-8M-30	142	1136	44.7	0.41
1136-8M-50	142	1136	44.7	0.69
1136-8M-85	142	1136	44.7	1.17
1152-8M-20	144	1152	45.4	0.28
1152-8M-30	144	1152	45.4	0.42
1152-8M-50	144	1152	45.4	0.70
1152-8M-85	144	1152	45.4	1.18
1160-8M-20	145	1160	45.7	0.28
1160-8M-30	145	1160	45.7	0.42
1160-8M-50	145	1160	45.7	0.70

Part Number	Number Of Teeth	Pitch Length		Weight (lbs)
		(mm)	(in)	
8M Pitch – High Torque Synchronous (HTS) Sprockets: MPB, QD, Taper Bushed (8mm)				
1160-8M-85	145	1160	45.7	1.19
1168-8M-20	146	1168	46.0	0.28
1168-8M-30	146	1168	46.0	0.42
1168-8M-50	146	1168	46.0	0.71
1168-8M-85	146	1168	46.0	1.20
1184-8M-20	148	1184	46.6	0.29
1184-8M-30	148	1184	46.6	0.43
1184-8M-50	148	1184	46.6	0.71
1184-8M-85	148	1184	46.6	1.22
1200-8M-20	150	1200	47.2	0.29
1200-8M-30	150	1200	47.2	0.43
1200-8M-50	150	1200	47.2	0.72
1200-8M-85	150	1200	47.2	1.23
1208-8M-20	151	1208	47.6	0.29
1208-8M-30	151	1208	47.6	0.44
1208-8M-50	151	1208	47.6	0.73
1208-8M-85	151	1208	47.6	1.24
1216-8M-20	152	1216	47.9	0.29
1216-8M-30	152	1216	47.9	0.44
1216-8M-50	152	1216	47.9	0.73
1216-8M-85	152	1216	47.9	1.25
1224-8M-20	153	1224	48.2	0.30
1224-8M-30	153	1224	48.2	0.44
1224-8M-50	153	1224	48.2	0.74
1224-8M-85	153	1224	48.2	1.26
1240-8M-20	155	1240	48.8	0.30
1240-8M-30	155	1240	48.8	0.45
1240-8M-50	155	1240	48.8	0.75
1240-8M-85	155	1240	48.8	1.27
1248-8M-20	156	1248	49.1	0.30
1248-8M-30	156	1248	49.1	0.45
1248-8M-50	156	1248	49.1	0.75
1248-8M-85	156	1248	49.1	1.28

Synchro-Cog® HT

Synchronous Drive Belt

Part Number Example: **1400-8M-50** = **1400** - **8M** - **50**
Pitch Length (millimeters) Tooth Pitch (HTD profile) Width (millimeters)

Part Number	Number Of Teeth	Pitch Length		Weight (lbs)
		(mm)	(in)	
8M Pitch – High Torque Synchronous (HTS) Sprockets: MPB, QD, Taper Bushed (8mm)				
1256-8M-20	157	1256	49.4	0.30
1256-8M-30	157	1256	49.4	0.46
1256-8M-50	157	1256	49.4	0.76
1256-8M-85	157	1256	49.4	1.29
1264-8M-20	158	1264	49.8	0.31
1264-8M-30	158	1264	49.8	0.46
1264-8M-50	158	1264	49.8	0.76
1264-8M-85	158	1264	49.8	1.30
1272-8M-20	159	1272	50.1	0.31
1272-8M-30	159	1272	50.1	0.46
1272-8M-50	159	1272	50.1	0.77
1272-8M-85	159	1272	50.1	1.31
1280-8M-20	160	1280	50.4	0.31
1280-8M-30	160	1280	50.4	0.46
1280-8M-50	160	1280	50.4	0.77
1280-8M-85	160	1280	50.4	1.31
1304-8M-20	163	1304	51.3	0.31
1304-8M-30	163	1304	51.3	0.47
1304-8M-50	163	1304	51.3	0.79
1304-8M-85	163	1304	51.3	1.34
1312-8M-20	164	1312	51.7	0.32
1312-8M-30	164	1312	51.7	0.48
1312-8M-50	164	1312	51.7	0.79
1312-8M-85	164	1312	51.7	1.35
1320-8M-20	165	1320	52.0	0.32
1320-8M-30	165	1320	52.0	0.48
1320-8M-50	165	1320	52.0	0.80
1320-8M-85	165	1320	52.0	1.36
1328-8M-20	166	1328	52.3	0.32
1328-8M-30	166	1328	52.3	0.48
1328-8M-50	166	1328	52.3	0.80
1328-8M-85	166	1328	52.3	1.36
1344-8M-20	168	1344	52.9	0.32

Part Number	Number Of Teeth	Pitch Length		Weight (lbs)
		(mm)	(in)	
8M Pitch – High Torque Synchronous (HTS) Sprockets: MPB, QD, Taper Bushed (8mm)				
1344-8M-30	168	1344	52.9	0.49
1344-8M-50	168	1344	52.9	0.81
1344-8M-85	168	1344	52.9	1.38
1352-8M-20	169	1352	53.2	0.33
1352-8M-30	169	1352	53.2	0.49
1352-8M-50	169	1352	53.2	0.82
1352-8M-85	169	1352	53.2	1.39
1360-8M-20	170	1360	53.5	0.33
1360-8M-30	170	1360	53.5	0.49
1360-8M-50	170	1360	53.5	0.82
1360-8M-85	170	1360	53.5	1.40
1376-8M-20	172	1376	54.2	0.33
1376-8M-30	172	1376	54.2	0.50
1376-8M-50	172	1376	54.2	0.83
1376-8M-85	172	1376	54.2	1.41
1392-8M-20	174	1392	54.8	0.34
1392-8M-30	174	1392	54.8	0.50
1392-8M-50	174	1392	54.8	0.84
1392-8M-85	174	1392	54.8	1.43
1400-8M-20	175	1400	55.1	0.34
1400-8M-30	175	1400	55.1	0.51
1400-8M-50	175	1400	55.1	0.85
1400-8M-85	175	1400	55.1	1.44
1424-8M-20	178	1424	56.1	0.34
1424-8M-30	178	1424	56.1	0.52
1424-8M-50	178	1424	56.1	0.86
1424-8M-85	178	1424	56.1	1.46
1440-8M-20	180	1440	56.7	0.35
1440-8M-30	180	1440	56.7	0.52
1440-8M-50	180	1440	56.7	0.87
1440-8M-85	180	1440	56.7	1.48
1456-8M-20	182	1456	57.3	0.35
1456-8M-30	182	1456	57.3	0.53

Synchro-Cog® HT

Synchronous Drive Belt

Synchro-Cog® HT

Part Numbers

Part Number	Number Of Teeth	Pitch Length		Weight (lbs)
		(mm)	(in)	
8M Pitch – High Torque Synchronous (HTS) Sprockets: MPB, QD, Taper Bushed (8mm)				
1456-8M-50	182	1456	57.3	0.88
1456-8M-85	182	1456	57.3	1.49
1464-8M-20	183	1464	57.6	0.35
1464-8M-30	183	1464	57.6	0.53
1464-8M-50	183	1464	57.6	0.88
1464-8M-85	183	1464	57.6	1.50
1480-8M-20	185	1480	58.3	0.36
1480-8M-30	185	1480	58.3	0.54
1480-8M-50	185	1480	58.3	0.89
1480-8M-85	185	1480	58.3	1.52
1512-8M-20	189	1512	59.5	0.37
1512-8M-30	189	1512	59.5	0.55
1512-8M-50	189	1512	59.5	0.91
1512-8M-85	189	1512	59.5	1.55
1520-8M-20	190	1520	59.8	0.37
1520-8M-30	190	1520	59.8	0.55
1520-8M-50	190	1520	59.8	0.92
1520-8M-85	190	1520	59.8	1.56
1552-8M-20	194	1552	61.1	0.37
1552-8M-30	194	1552	61.1	0.56
1552-8M-50	194	1552	61.1	0.94
1552-8M-85	194	1552	61.1	1.59
1560-8M-20	195	1560	61.4	0.38
1560-8M-30	195	1560	61.4	0.57
1560-8M-50	195	1560	61.4	0.94
1560-8M-85	195	1560	61.4	1.60
1576-8M-20	197	1576	62.0	0.38
1576-8M-30	197	1576	62.0	0.57
1576-8M-50	197	1576	62.0	0.95
1576-8M-85	197	1576	62.0	1.62
1584-8M-20	198	1584	62.4	0.38
1584-8M-30	198	1584	62.4	0.57
1584-8M-50	198	1584	62.4	0.96

Part Number	Number Of Teeth	Pitch Length		Weight (lbs)
		(mm)	(in)	
8M Pitch – High Torque Synchronous (HTS) Sprockets: MPB, QD, Taper Bushed (8mm)				
1584-8M-85	198	1584	62.4	1.63
1600-8M-20	200	1600	63.0	0.39
1600-8M-30	200	1600	63.0	0.58
1600-8M-50	200	1600	63.0	0.97
1600-8M-85	200	1600	63.0	1.64
1640-8M-20	205	1640	64.6	0.40
1640-8M-30	205	1640	64.6	0.59
1640-8M-50	205	1640	64.6	0.99
1640-8M-85	205	1640	64.6	1.68
1648-8M-20	206	1648	64.9	0.40
1648-8M-30	206	1648	64.9	0.60
1648-8M-50	206	1648	64.9	1.00
1648-8M-85	206	1648	64.9	1.69
1680-8M-20	210	1680	66.1	0.41
1680-8M-30	210	1680	66.1	0.61
1680-8M-50	210	1680	66.1	1.01
1680-8M-85	210	1680	66.1	1.72
1696-8M-20	212	1696	66.8	0.41
1696-8M-30	212	1696	66.8	0.61
1696-8M-50	212	1696	66.8	1.02
1696-8M-85	212	1696	66.8	1.74
1728-8M-20	216	1728	68.0	0.42
1728-8M-30	216	1728	68.0	0.63
1728-8M-50	216	1728	68.0	1.04
1728-8M-85	216	1728	68.0	1.77
1744-8M-20	218	1744	68.7	0.42
1744-8M-30	218	1744	68.7	0.63
1744-8M-50	218	1744	68.7	1.05
1744-8M-85	218	1744	68.7	1.79
1752-8M-20	219	1752	69.0	0.42
1752-8M-30	219	1752	69.0	0.63
1752-8M-50	219	1752	69.0	1.06
1752-8M-85	219	1752	69.0	1.80

Synchro-Cog® HT

Synchronous Drive Belt

Part Number Example: **2000-8M-50** = **2000** - **8M** - **50**
Pitch Length (millimeters) Tooth Pitch (HTD profile) Width (millimeters)

Part Number	Number Of Teeth	Pitch Length		Weight (lbs)
		(mm)	(in)	
8M Pitch – High Torque Synchronous (HTS) Sprockets: MPB, QD, Taper Bushed (8mm)				
1760-8M-20	220	1760	69.3	0.43
1760-8M-30	220	1760	69.3	0.64
1760-8M-50	220	1760	69.3	1.06
1760-8M-85	220	1760	69.3	1.81
1784-8M-20	223	1784	70.2	0.43
1784-8M-30	223	1784	70.2	0.65
1784-8M-50	223	1784	70.2	1.08
1784-8M-85	223	1784	70.2	1.83
1792-8M-20	224	1792	70.6	0.43
1792-8M-30	224	1792	70.6	0.65
1792-8M-50	224	1792	70.6	1.08
1792-8M-85	224	1792	70.6	1.84
1800-8M-20	225	1800	70.9	0.43
1800-8M-30	225	1800	70.9	0.65
1800-8M-50	225	1800	70.9	1.09
1800-8M-85	225	1800	70.9	1.85
1840-8M-20	230	1840	72.4	0.44
1840-8M-30	230	1840	72.4	0.67
1840-8M-50	230	1840	72.4	1.11
1840-8M-85	230	1840	72.4	1.89
1856-8M-20	232	1856	73.1	0.45
1856-8M-30	232	1856	73.1	0.67
1856-8M-50	232	1856	73.1	1.12
1856-8M-85	232	1856	73.1	1.91
1896-8M-20	237	1896	74.6	0.46
1896-8M-30	237	1896	74.6	0.69
1896-8M-50	237	1896	74.6	1.14
1896-8M-85	237	1896	74.6	1.95
1904-8M-20	238	1904	75.0	0.46
1904-8M-30	238	1904	75.0	0.69
1904-8M-50	238	1904	75.0	1.15
1904-8M-85	238	1904	75.0	1.95
1920-8M-20	240	1920	75.6	0.46

Part Number	Number Of Teeth	Pitch Length		Weight (lbs)
		(mm)	(in)	
8M Pitch – High Torque Synchronous (HTS) Sprockets: MPB, QD, Taper Bushed (8mm)				
1920-8M-30	240	1920	75.6	0.70
1920-8M-50	240	1920	75.6	1.16
1920-8M-85	240	1920	75.6	1.97
1928-8M-20	241	1928	75.9	0.47
1928-8M-30	241	1928	75.9	0.70
1928-8M-50	241	1928	75.9	1.16
1928-8M-85	241	1928	75.9	1.98
1936-8M-20	242	1936	76.2	0.47
1936-8M-30	242	1936	76.2	0.70
1936-8M-50	242	1936	76.2	1.17
1936-8M-85	242	1936	76.2	1.99
1952-8M-20	244	1952	76.9	0.47
1952-8M-30	244	1952	76.9	0.71
1952-8M-50	244	1952	76.9	1.18
1952-8M-85	244	1952	76.9	2.00
1992-8M-20	249	1992	78.4	0.48
1992-8M-30	249	1992	78.4	0.72
1992-8M-50	249	1992	78.4	1.20
1992-8M-85	249	1992	78.4	2.04
2000-8M-20	250	2000	78.7	0.48
2000-8M-30	250	2000	78.7	0.72
2000-8M-50	250	2000	78.7	1.21
2000-8M-85	250	2000	78.7	2.05
2048-8M-20	256	2048	80.6	0.49
2048-8M-30	256	2048	80.6	0.73
2048-8M-50	256	2048	80.6	1.23
2048-8M-85	256	2048	80.6	2.09
2056-8M-20	257	2056	80.9	0.50
2056-8M-30	257	2056	80.9	0.74
2056-8M-50	257	2056	80.9	1.24
2056-8M-85	257	2056	80.9	2.11
2080-8M-20	260	2080	81.9	0.50
2080-8M-30	260	2080	81.9	0.75

Synchro-Cog® HT

Synchronous Drive Belt

Synchro-Cog® HT

Part Numbers

Part Number	Number Of Teeth	Pitch Length		Weight (lbs)
		(mm)	(in)	
8M Pitch – High Torque Synchronous (HTS) Sprockets: MPB, QD, Taper Bushed (8mm)				
2080-8M-50	260	2080	81.9	1.26
2080-8M-85	260	2080	81.9	2.14
2104-8M-20	263	2104	82.8	0.51
2104-8M-30	263	2104	82.8	0.76
2104-8M-50	263	2104	82.8	1.27
2104-8M-85	263	2104	82.8	2.16
2136-8M-20	267	2136	84.1	0.52
2136-8M-30	267	2136	84.1	0.77
2136-8M-50	267	2136	84.1	1.29
2136-8M-85	267	2136	84.1	2.19
2160-8M-20	270	2160	85.0	0.52
2160-8M-30	270	2160	85.0	0.78
2160-8M-50	270	2160	85.0	1.30
2160-8M-85	270	2160	85.0	2.22
2208-8M-20	276	2208	86.9	0.53
2208-8M-30	276	2208	86.9	0.80
2208-8M-50	276	2208	86.9	1.33
2208-8M-85	276	2208	86.9	2.27
2240-8M-20	280	2240	88.2	0.54
2240-8M-30	280	2240	88.2	0.81
2240-8M-50	280	2240	88.2	1.35
2240-8M-85	280	2240	88.2	2.30
2272-8M-20	284	2272	89.4	0.55
2272-8M-30	284	2272	89.4	0.82
2272-8M-50	284	2272	89.4	1.37
2272-8M-85	284	2272	89.4	2.33
2304-8M-20	288	2304	90.7	0.56
2304-8M-30	288	2304	90.7	0.83
2304-8M-50	288	2304	90.7	1.39
2304-8M-85	288	2304	90.7	2.37
2328-8M-20	291	2328	91.7	0.56
2328-8M-30	291	2328	91.7	0.84
2328-8M-50	291	2328	91.7	1.41

Part Number	Number Of Teeth	Pitch Length		Weight (lbs)
		(mm)	(in)	
8M Pitch – High Torque Synchronous (HTS) Sprockets: MPB, QD, Taper Bushed (8mm)				
2328-8M-85	291	2328	91.7	2.39
2392-8M-20	299	2392	94.2	0.58
2392-8M-30	299	2392	94.2	0.87
2392-8M-50	299	2392	94.2	1.44
2392-8M-85	299	2392	94.2	2.46
2400-8M-20	300	2400	94.5	0.58
2400-8M-30	300	2400	94.5	0.87
2400-8M-50	300	2400	94.5	1.45
2400-8M-85	300	2400	94.5	2.46
2504-8M-20	313	2504	98.6	0.60
2504-8M-30	313	2504	98.6	0.91
2504-8M-50	313	2504	98.6	1.51
2504-8M-85	313	2504	98.6	2.57
2584-8M-20	323	2584	101.7	0.62
2584-8M-30	323	2584	101.7	0.94
2584-8M-50	323	2584	101.7	1.56
2584-8M-85	323	2584	101.7	2.65
2600-8M-20	325	2600	102.4	0.63
2600-8M-30	325	2600	102.4	0.94
2600-8M-50	325	2600	102.4	1.57
2600-8M-85	325	2600	102.4	2.67
2656-8M-20	332	2656	104.6	0.64
2656-8M-30	332	2656	104.6	0.96
2656-8M-50	332	2656	104.6	1.60
2656-8M-85	332	2656	104.6	2.73
2736-8M-20	342	2736	107.7	0.66
2736-8M-30	342	2736	107.7	0.99
2736-8M-50	342	2736	107.7	1.65
2736-8M-85	342	2736	107.7	2.81
2800-8M-20	350	2800	110.2	0.68
2800-8M-30	350	2800	110.2	1.01
2800-8M-50	350	2800	110.2	1.69
2800-8M-85	350	2800	110.2	2.87

Synchro-Cog® HT

Synchronous Drive Belt

Part Number Example: **3200-8M-50** = **3200** - **8M** - **50**
Pitch Length (millimeters) Tooth Pitch (HTD profile) Width (millimeters)

Part Number	Number Of Teeth	Pitch Length		Weight (lbs)
		(mm)	(in)	
8M Pitch – High Torque Synchronous (HTS) Sprockets: MPB, QD, Taper Bushed (8mm)				
3048-8M-20	381	3048	120.0	0.74
3048-8M-30	381	3048	120.0	1.10
3048-8M-50	381	3048	120.0	1.84
3048-8M-85	381	3048	120.0	3.13
3120-8M-20	390	3120	122.8	0.75
3120-8M-30	390	3120	122.8	1.13
3120-8M-50	390	3120	122.8	1.88
3120-8M-85	390	3120	122.8	3.20
3168-8M-20	396	3168	124.7	0.77
3168-8M-30	396	3168	124.7	1.15
3168-8M-50	396	3168	124.7	1.91
3168-8M-85	396	3168	124.7	3.25
3200-8M-20	400	3200	126.0	0.77
3200-8M-30	400	3200	126.0	1.16
3200-8M-50	400	3200	126.0	1.93
3200-8M-85	400	3200	126.0	3.28
3280-8M-20	410	3280	129.1	0.79
3280-8M-30	410	3280	129.1	1.19
3280-8M-50	410	3280	129.1	1.98
3280-8M-85	410	3280	129.1	3.37
3400-8M-20	425	3400	133.9	0.82
3400-8M-30	425	3400	133.9	1.23
3400-8M-50	425	3400	133.9	2.05
3400-8M-85	425	3400	133.9	3.49
3600-8M-20	450	3600	141.7	0.87
3600-8M-30	450	3600	141.7	1.30
3600-8M-50	450	3600	141.7	2.17
3600-8M-85	450	3600	141.7	3.70
3824-8M-20	478	3824	150.6	0.92
3824-8M-30	478	3824	150.6	1.39
3824-8M-50	478	3824	150.6	2.31
3824-8M-85	478	3824	150.6	3.93
4000-8M-20	500	4000	157.5	0.97

Part Number	Number Of Teeth	Pitch Length		Weight (lbs)
		(mm)	(in)	
8M Pitch – High Torque Synchronous (HTS) Sprockets: MPB, QD, Taper Bushed (8mm)				
4000-8M-30	500	4000	157.5	1.45
4000-8M-50	500	4000	157.5	2.42
4000-8M-85	500	4000	157.5	4.11
4400-8M-20	550	4400	173.2	1.06
4400-8M-30	550	4400	173.2	1.59
4400-8M-50	550	4400	173.2	2.66
4400-8M-85	550	4400	173.2	4.52
5120-8M-20	640	5120	201.6	1.24
5120-8M-30	640	5120	201.6	1.86
5120-8M-50	640	5120	201.6	3.09
5120-8M-85	640	5120	201.6	5.26
5576-8M-20	697	5576	219.5	1.35
5576-8M-30	697	5576	219.5	2.02
5576-8M-50	697	5576	219.5	3.37
5576-8M-85	697	5576	219.5	5.72
5600-8M-20	700	5600	220.5	1.35
5600-8M-30	700	5600	220.5	2.03
5600-8M-50	700	5600	220.5	3.38
5600-8M-85	700	5600	220.5	5.75
5960-8M-20	745	5960	234.6	1.44
5960-8M-30	745	5960	234.6	2.16
5960-8M-50	745	5960	234.6	3.60
5960-8M-85	745	5960	234.6	6.12
14M Pitch – High Torque Synchronous (HTS) Sprockets: MPB, QD, Taper Bushed (14mm)				
966-14M-40	69	966	38.0	0.76
966-14M-55	69	966	38.0	1.04
966-14M-85	69	966	38.0	1.61
966-14M-115	69	966	38.0	2.18
966-14M-170	69	966	38.0	3.22
1036-14M-40	74	1036	40.8	0.81
1036-14M-55	74	1036	40.8	1.12
1036-14M-85	74	1036	40.8	1.72

Synchro-Cog® HT

Synchronous Drive Belt

Synchro-Cog® HT

Part Numbers

Part Number	Number Of Teeth	Pitch Length		Weight (lbs)
		(mm)	(in)	
14M Pitch – High Torque Synchronous (HTS) Sprockets: MPB, QD, Taper Bushed (14mm)				
1036-14M-115	74	1036	40.8	2.33
1036-14M-170	74	1036	40.8	3.45
1092-14M-40	78	1092	43.0	0.86
1092-14M-55	78	1092	43.0	1.18
1092-14M-85	78	1092	43.0	1.82
1092-14M-115	78	1092	43.0	2.46
1092-14M-170	78	1092	43.0	3.64
1120-14M-40	80	1120	44.1	0.88
1120-14M-55	80	1120	44.1	1.21
1120-14M-85	80	1120	44.1	1.86
1120-14M-115	80	1120	44.1	2.52
1120-14M-170	80	1120	44.1	3.73
1148-14M-40	82	1148	45.2	0.90
1148-14M-55	82	1148	45.2	1.24
1148-14M-85	82	1148	45.2	1.91
1148-14M-115	82	1148	45.2	2.59
1148-14M-170	82	1148	45.2	3.82
1190-14M-40	85	1190	46.9	0.93
1190-14M-55	85	1190	46.9	1.28
1190-14M-85	85	1190	46.9	1.98
1190-14M-115	85	1190	46.9	2.68
1190-14M-170	85	1190	46.9	3.96
1246-14M-40	89	1246	49.1	0.98
1246-14M-55	89	1246	49.1	1.34
1246-14M-85	89	1246	49.1	2.07
1246-14M-115	89	1246	49.1	2.81
1246-14M-170	89	1246	49.1	4.15
1260-14M-40	90	1260	49.6	0.99
1260-14M-55	90	1260	49.6	1.36
1260-14M-85	90	1260	49.6	2.10
1260-14M-115	90	1260	49.6	2.84
1260-14M-170	90	1260	49.6	4.19
1288-14M-40	92	1288	50.7	1.02

Part Number	Number Of Teeth	Pitch Length		Weight (lbs)
		(mm)	(in)	
14M Pitch – High Torque Synchronous (HTS) Sprockets: MPB, QD, Taper Bushed (14mm)				
1288-14M-55	92	1288	50.7	1.32
1288-14M-85	92	1288	50.7	2.14
1288-14M-115	92	1288	50.7	2.80
1288-14M-170	92	1288	50.7	4.20
1316-14M-40	94	1316	51.8	1.03
1316-14M-55	94	1316	51.8	1.42
1316-14M-85	94	1316	51.8	2.19
1316-14M-115	94	1316	51.8	2.96
1316-14M-170	94	1316	51.8	4.38
1344-14M-40	96	1344	52.9	1.05
1344-14M-55	96	1344	52.9	1.45
1344-14M-85	96	1344	52.9	2.24
1344-14M-115	96	1344	52.9	3.03
1344-14M-170	96	1344	52.9	4.47
1400-14M-40	100	1400	55.1	1.10
1400-14M-55	100	1400	55.1	1.51
1400-14M-85	100	1400	55.1	2.33
1400-14M-115	100	1400	55.1	3.15
1400-14M-170	100	1400	55.1	4.66
1442-14M-40	103	1442	56.8	1.13
1442-14M-55	103	1442	56.8	1.55
1442-14M-85	103	1442	56.8	2.40
1442-14M-115	103	1442	56.8	3.25
1442-14M-170	103	1442	56.8	4.80
1456-14M-40	104	1456	57.3	1.14
1456-14M-55	104	1456	57.3	1.57
1456-14M-85	104	1456	57.3	2.42
1456-14M-115	104	1456	57.3	3.28
1456-14M-170	104	1456	57.3	4.85
1470-14M-40	105	1470	57.9	1.15
1470-14M-55	105	1470	57.9	1.58
1470-14M-85	105	1470	57.9	2.45
1470-14M-115	105	1470	57.9	3.31

Synchro-Cog® HT

Synchronous Drive Belt

Part Number Example: **2100-14M-40** = **2100** - **14M** - **40**
Pitch Length (millimeters) Tooth Pitch (HTD profile) Width (millimeters)

Part Number	Number Of Teeth	Pitch Length		Weight (lbs)
		(mm)	(in)	
14M Pitch – High Torque Synchronous (HTS) Sprockets: MPB, QD, Taper Bushed (14mm)				
1470-14M-170	105	1470	57.9	4.89
1540-14M-40	110	1540	60.6	1.21
1540-14M-55	110	1540	60.6	1.66
1540-14M-85	110	1540	60.6	2.56
1540-14M-115	110	1540	60.6	3.47
1540-14M-170	110	1540	60.6	5.13
1568-14M-40	112	1568	61.7	1.23
1568-14M-55	112	1568	61.7	1.69
1568-14M-85	112	1568	61.7	2.61
1568-14M-115	112	1568	61.7	3.53
1568-14M-170	112	1568	61.7	5.22
1610-14M-40	115	1610	63.4	1.26
1610-14M-55	115	1610	63.4	1.73
1610-14M-85	115	1610	63.4	2.68
1610-14M-115	115	1610	63.4	3.63
1610-14M-170	115	1610	63.4	5.36
1652-14M-40	118	1652	65.0	1.29
1652-14M-55	118	1652	65.0	1.78
1652-14M-85	118	1652	65.0	2.75
1652-14M-115	118	1652	65.0	3.72
1652-14M-170	118	1652	65.0	5.50
1750-14M-40	125	1750	68.9	1.37
1750-14M-55	125	1750	68.9	1.88
1750-14M-85	125	1750	68.9	2.91
1750-14M-115	125	1750	68.9	3.94
1750-14M-170	125	1750	68.9	5.83
1764-14M-40	126	1764	69.4	1.38
1764-14M-55	126	1764	69.4	1.90
1764-14M-85	126	1764	69.4	2.94
1764-14M-115	126	1764	69.4	3.97
1764-14M-170	126	1764	69.4	5.87
1778-14M-40	127	1778	70.0	1.39
1778-14M-55	127	1778	70.0	1.91

Part Number	Number Of Teeth	Pitch Length		Weight (lbs)
		(mm)	(in)	
14M Pitch – High Torque Synchronous (HTS) Sprockets: MPB, QD, Taper Bushed (14mm)				
1778-14M-85	127	1778	70.0	2.96
1778-14M-115	127	1778	70.0	4.00
1778-14M-170	127	1778	70.0	5.92
1792-14M-40	128	1792	70.6	1.40
1792-14M-55	128	1792	70.6	1.93
1792-14M-85	128	1792	70.6	2.98
1792-14M-115	128	1792	70.6	4.04
1792-14M-170	128	1792	70.6	5.97
1806-14M-40	129	1806	71.1	1.41
1806-14M-55	129	1806	71.1	1.95
1806-14M-85	129	1806	71.1	3.01
1806-14M-115	129	1806	71.1	4.07
1806-14M-170	129	1806	71.1	6.01
1820-14M-40	130	1820	71.7	1.43
1820-14M-55	130	1820	71.7	1.96
1820-14M-85	130	1820	71.7	3.03
1820-14M-115	130	1820	71.7	4.10
1820-14M-170	130	1820	71.7	6.06
1890-14M-40	135	1890	74.4	1.48
1890-14M-55	135	1890	74.4	2.04
1890-14M-85	135	1890	74.4	3.15
1890-14M-115	135	1890	74.4	4.26
1890-14M-170	135	1890	74.4	6.29
1932-14M-40	138	1932	76.1	1.51
1932-14M-55	138	1932	76.1	2.08
1932-14M-85	138	1932	76.1	3.22
1932-14M-115	138	1932	76.1	4.35
1932-14M-170	138	1932	76.1	6.43
1960-14M-40	140	1960	77.2	1.54
1960-14M-55	140	1960	77.2	2.11
1960-14M-85	140	1960	77.2	3.26
1960-14M-115	140	1960	77.2	4.41
1960-14M-170	140	1960	77.2	6.52

Synchro-Cog® HT

Synchronous Drive Belt

Synchro-Cog® HT

Part Numbers

Part Number	Number Of Teeth	Pitch Length		Weight (lbs)
		(mm)	(in)	
14M Pitch – High Torque Synchronous (HTS) Sprockets: MPB, QD, Taper Bushed (14mm)				
2100-14M-40	150	2100	82.7	1.64
2100-14M-55	150	2100	82.7	2.26
2100-14M-85	150	2100	82.7	3.50
2100-14M-115	150	2100	82.7	4.73
2100-14M-170	150	2100	82.7	6.99
2240-14M-40	160	2240	88.2	1.75
2240-14M-55	160	2240	88.2	2.41
2240-14M-85	160	2240	88.2	3.73
2240-14M-115	160	2240	88.2	5.04
2240-14M-170	160	2240	88.2	7.46
2310-14M-40	165	2310	90.9	1.81
2310-14M-55	165	2310	90.9	2.49
2310-14M-85	165	2310	90.9	3.85
2310-14M-115	165	2310	90.9	5.20
2310-14M-170	165	2310	90.9	7.69
2450-14M-40	175	2450	96.5	1.92
2450-14M-55	175	2450	96.5	2.64
2450-14M-85	175	2450	96.5	4.08
2450-14M-115	175	2450	96.5	5.52
2450-14M-170	175	2450	96.5	8.16
2590-14M-40	185	2590	102.0	2.03
2590-14M-55	185	2590	102.0	2.79
2590-14M-85	185	2590	102.0	4.31
2590-14M-115	185	2590	102.0	5.83
2590-14M-170	185	2590	102.0	8.62
2660-14M-40	190	2660	104.7	2.08
2660-14M-55	190	2660	104.7	2.86
2660-14M-85	190	2660	104.7	4.43
2660-14M-115	190	2660	104.7	5.99
2660-14M-170	190	2660	104.7	8.86
2800-14M-40	200	2800	110.2	2.19
2800-14M-55	200	2800	110.2	3.02
2800-14M-85	200	2800	110.2	4.66

Part Number	Number Of Teeth	Pitch Length		Weight (lbs)
		(mm)	(in)	
14M Pitch – High Torque Synchronous (HTS) Sprockets: MPB, QD, Taper Bushed (14mm)				
2800-14M-115	200	2800	110.2	6.31
2800-14M-170	200	2800	110.2	9.32
3108-14M-40	222	3108	122.4	2.43
3108-14M-55	222	3108	122.4	3.35
3108-14M-85	222	3108	122.4	5.17
3108-14M-115	222	3108	122.4	7.00
3108-14M-170	222	3108	122.4	10.35
3150-14M-40	225	3150	124.0	2.47
3150-14M-55	225	3150	124.0	3.39
3150-14M-85	225	3150	124.0	5.24
3150-14M-115	225	3150	124.0	7.09
3150-14M-170	225	3150	124.0	10.49
3304-14M-40	236	3304	130.1	2.59
3304-14M-55	236	3304	130.1	3.56
3304-14M-85	236	3304	130.1	5.50
3304-14M-115	236	3304	130.1	7.44
3304-14M-170	236	3304	130.1	11.00
3360-14M-40	240	3360	132.3	2.63
3360-14M-55	240	3360	132.3	3.62
3360-14M-85	240	3360	132.3	5.59
3360-14M-115	240	3360	132.3	7.57
3360-14M-170	240	3360	132.3	11.19
3500-14M-40	250	3500	137.8	2.74
3500-14M-55	250	3500	137.8	3.77
3500-14M-85	250	3500	137.8	5.83
3500-14M-115	250	3500	137.8	7.88
3500-14M-170	250	3500	137.8	11.65
3668-14M-40	262	3668	144.4	2.87
3668-14M-55	262	3668	144.4	3.95
3668-14M-85	262	3668	144.4	6.11
3668-14M-115	262	3668	144.4	8.26
3668-14M-170	262	3668	144.4	12.21
3850-14M-40	275	3850	151.6	3.02

Synchro-Cog® HT

Synchronous Drive Belt

Part Number Example: **3500-14M-55** = **3500** - **14M** - **55**
Pitch Length (millimeters) Tooth Pitch (HTD profile) Width (millimeters)

Part Number	Number Of Teeth	Pitch Length		Weight (lbs)
		(mm)	(in)	
14M Pitch – High Torque Synchronous (HTS) Sprockets: MPB, QD, Taper Bushed (14mm)				
3850-14M-55	275	3850	151.6	4.15
3850-14M-85	275	3850	151.6	6.41
3850-14M-115	275	3850	151.6	8.67
3850-14M-170	275	3850	151.6	12.82
4326-14M-40	309	4326	170.3	3.39
4326-14M-55	309	4326	170.3	4.66
4326-14M-85	309	4326	170.3	7.20
4326-14M-115	309	4326	170.3	9.74
4326-14M-170	309	4326	170.3	14.40
4536-14M-40	324	4536	178.6	3.55
4536-14M-55	324	4536	178.6	4.89
4536-14M-85	324	4536	178.6	7.55
4536-14M-115	324	4536	178.6	10.22
4536-14M-170	324	4536	178.6	15.10
4578-14M-40	327	4578	180.2	3.59
4578-14M-55	327	4578	180.2	4.93
4578-14M-85	327	4578	180.2	7.62
4578-14M-115	327	4578	180.2	10.31
4578-14M-170	327	4578	180.2	15.24
4956-14M-40	354	4956	195.1	3.88
4956-14M-55	354	4956	195.1	5.34
4956-14M-85	354	4956	195.1	8.25
4956-14M-115	354	4956	195.1	11.16
4956-14M-170	354	4956	195.1	16.50
5320-14M-40	380	5320	209.4	4.17
5320-14M-55	380	5320	209.4	5.73
5320-14M-85	380	5320	209.4	8.86
5320-14M-115	380	5320	209.4	11.98
5320-14M-170	380	5320	209.4	17.71
5740-14M-40	410	5740	226.0	4.50
5740-14M-55	410	5740	226.0	6.18
5740-14M-85	410	5740	226.0	9.55
5740-14M-115	410	5740	226.0	12.93

Part Number	Number Of Teeth	Pitch Length		Weight (lbs)
		(mm)	(in)	
14M Pitch – High Torque Synchronous (HTS) Sprockets: MPB, QD, Taper Bushed (14mm)				
5740-14M-170	410	5740	226.0	19.11
6160-14M-40	440	6160	242.5	4.83
6160-14M-55	440	6160	242.5	6.63
6160-14M-85	440	6160	242.5	10.25
6160-14M-115	440	6160	242.5	13.87
6160-14M-170	440	6160	242.5	20.51
6860-14M-40	490	6860	270.1	5.37
6860-14M-55	490	6860	270.1	7.39
6860-14M-85	490	6860	270.1	11.42
6860-14M-115	490	6860	270.1	15.45
6860-14M-170	490	6860	270.1	22.84



Synchro-Cog® HT Sleeves



- Full factory width sleeves
- Sleeve edges are trimmed before shipment
- Sleeves cannot be accepted for return

Timken maintains inventory of most synchronous sleeve sizes. Contact customer service for availability. Minimum order quantity and/or lead times may apply.

Occasional production inconsistencies which may render a portion of the sleeve unusable can be present as a normal part of the production process.

Each sleeve is inspected to ensure that it contains 90% or more usable product. A full width sleeve with less than 10% unusable product is considered acceptable.



Synchro-Cog® HT Sleeve Part Numbers

Part Number	Sleeve Width (mm)	Sleeve Weight (lbs)
3M Pitch – High Torque Synchronous (HTS) Sprockets: MPB, QD, Taper Bushed (3mm)		
144-3M-100SL	100	0.1
150-3M-160SL	160	0.1
159-3M-200SL	200	0.2
168-3M-200SL	200	0.2
177-3M-200SL	200	0.2
180-3M-200SL	200	0.2
186-3M-160SL	160	0.2
189-3M-160SL	160	0.2
192-3M-160SL	160	0.2
201-3M-200SL	200	0.2
207-3M-200SL	200	0.2
210-3M-200SL	200	0.2
213-3M-200SL	200	0.2
222-3M-200SL	200	0.2
225-3M-200SL	200	0.2
228-3M-200SL	200	0.2
234-3M-200SL	200	0.3
240-3M-200SL	200	0.3
252-3M-450SL	450	0.6
255-3M-450SL	450	0.6
264-3M-450SL	450	0.6
267-3M-450SL	450	0.7
276-3M-450SL	450	0.7
285-3M-450SL	450	0.7
300-3M-450SL	450	0.7
312-3M-450SL	450	0.8
318-3M-450SL	450	0.8
324-3M-450SL	450	0.8
330-3M-450SL	450	0.8
339-3M-450SL	450	0.8
357-3M-450SL	450	0.9
360-3M-450SL	450	0.9
363-3M-450SL	450	0.9

Synchro-Cog® HT Sleeves

Part Number Example: **375-3M-450SL** = **375** - **3M** - **450** **SL**
Pitch Length (millimeters) Tooth Pitch (HTD profile) Width (millimeters) Sleeve

Part Number	Sleeve Width (mm)	Sleeve Weight (lbs)
3M Pitch – High Torque Synchronous (HTS) Sprockets: MPB, QD, Taper Bushed (3mm)		
375-3M-450SL	450	0.9
384-3M-450SL	450	0.9
390-3M-450SL	450	1.0
405-3M-450SL	450	1.0
420-3M-450SL	450	1.0
447-3M-450SL	450	1.1
456-3M-450SL	450	1.1
474-3M-450SL	450	1.2
483-3M-450SL	450	1.2
495-3M-450SL	450	1.2
501-3M-450SL	450	1.2
513-3M-450SL	450	1.2
522-3M-450SL	450	1.3
531-3M-450SL	450	1.3
564-3M-200SL	200	0.6
570-3M-450SL	450	1.4
582-3M-200SL	200	0.6
600-3M-450SL	450	1.5
669-3M-450SL	450	1.5
633-3M-450SL	450	1.5
711-3M-450SL	450	1.7
735-3M-450SL	450	1.8
750-3M-450SL	450	1.8
804-3M-450SL	450	2.0
1026-3M-450SL	450	2.5
1401-3M-200SL	200	1.5
5M Pitch – High Torque Synchronous (HTS) Sprockets: MPB, QD, Taper Bushed (5mm)		
180-5M-200SL	200	0.3
200-5M-200SL	200	0.4
210-5M-200SL	200	0.4
215-5M-200SL	200	0.4
225-5M-200SL	200	0.4

Part Number	Sleeve Width (mm)	Sleeve Weight (lbs)
5M Pitch – High Torque Synchronous (HTS) Sprockets: MPB, QD, Taper Bushed (5mm)		
230-5M-450SL	450	0.9
235-5M-200SL	200	0.4
245-5M-450SL	450	1.0
250-5M-450SL	450	1.0
255-5M-200SL	200	0.5
260-5M-450SL	450	1.0
265-5M-450SL	450	1.1
270-5M-450SL	450	1.1
275-5M-450SL	450	1.1
280-5M-450SL	450	1.1
285-5M-450SL	450	1.1
290-5M-450SL	450	1.2
295-5M-450SL	450	1.2
300-5M-450SL	450	1.2
305-5M-450SL	450	1.2
310-5M-450SL	450	1.2
320-5M-450SL	450	1.3
325-5M-450SL	450	1.3
330-5M-450SL	450	1.3
340-5M-450SL	450	1.4
345-5M-450SL	450	1.4
350-5M-450SL	450	1.4
360-5M-450SL	450	1.4
365-5M-450SL	450	1.5
370-5M-450SL	450	1.5
375-5M-450SL	450	1.5
380-5M-450SL	450	1.5
385-5M-450SL	450	1.5
390-5M-450SL	450	1.6
395-5M-450SL	450	1.6
400-5M-450SL	450	1.6
405-5M-450SL	450	1.6
410-5M-450SL	450	1.6

Synchro-Cog® HT

Sleeves

Synchro-Cog® HT Sleeve Part Numbers

Part Number	Sleeve Width (mm)	Sleeve Weight (lbs)
5M Pitch – High Torque Synchronous (HTS) Sprockets: MPB, OD, Taper Bushed (5mm)		
420-5M-450SL	450	1.7
425-5M-450SL	450	1.7
430-5M-450SL	450	1.7
435-5M-450SL	450	1.7
440-5M-450SL	450	1.8
445-5M-450SL	450	1.8
450-5M-450SL	450	1.8
460-5M-450SL	450	1.9
465-5M-450SL	450	1.9
470-5M-450SL	450	1.9
475-5M-450SL	450	1.9
480-5M-450SL	450	1.9
490-5M-450SL	450	2.0
500-5M-450SL	450	2.0
505-5M-450SL	450	2.0
510-5M-450SL	450	2.1
520-5M-450SL	450	2.1
525-5M-450SL	450	2.1
530-5M-450SL	450	2.1
535-5M-450SL	450	2.2
540-5M-450SL	450	2.2
550-5M-450SL	450	2.2
560-5M-450SL	450	2.3
565-5M-200SL	200	1.0
570-5M-450SL	450	2.3
575-5M-450SL	450	2.3
580-5M-450SL	450	2.3
585-5M-450SL	450	2.4
590-5M-450SL	450	2.4
600-5M-450SL	450	2.4
605-5M-450SL	450	2.4
610-5M-450SL	450	2.5
615-5M-450SL	450	2.5

Part Number	Sleeve Width (mm)	Sleeve Weight (lbs)
5M Pitch – High Torque Synchronous (HTS) Sprockets: MPB, OD, Taper Bushed (5mm)		
620-5M-450SL	450	2.5
625-5M-450SL	450	2.5
635-5M-450SL	450	2.6
640-5M-450SL	450	2.6
645-5M-450SL	450	2.6
650-5M-450SL	450	2.6
655-5M-450SL	450	2.6
665-5M-450SL	450	2.7
670-5M-450SL	450	2.7
675-5M-450SL	450	2.7
685-5M-450SL	450	2.8
690-5M-450SL	450	2.8
695-5M-450SL	450	2.8
700-5M-450SL	450	2.8
710-5M-450SL	450	2.9
720-5M-450SL	450	2.9
725-5M-450SL	450	2.9
740-5M-450SL	450	3.0
750-5M-450SL	450	3.0
755-5M-450SL	450	3.0
770-5M-450SL	450	3.1
775-5M-450SL	450	3.1
780-5M-450SL	450	3.1
790-5M-450SL	450	3.2
800-5M-450SL	450	3.2
810-5M-450SL	450	3.3
825-5M-450SL	450	3.3
835-5M-450SL	450	3.4
850-5M-450SL	450	3.4
860-5M-450SL	450	3.5
870-5M-450SL	450	3.5
890-5M-450SL	450	3.6
900-5M-450SL	450	3.6

Synchro-Cog® HT Sleeves

Part Number Example: **1000-5M-450SL** = **1000** - **5M** - **450** **SL**
Pitch Length (millimeters) Tooth Pitch (HTD profile) Width (millimeters) Sleeve

Part Number	Sleeve Width (mm)	Sleeve Weight (lbs)
5M Pitch – High Torque Synchronous (HTS) Sprockets: MPB, QD, Taper Bushed (5mm)		
920-5M-450SL	450	3.7
925-5M-450SL	450	3.7
935-5M-450SL	450	3.8
940-5M-450SL	450	3.8
950-5M-450SL	450	3.8
960-5M-450SL	450	3.9
965-5M-450SL	450	3.9
975-5M-450SL	450	3.9
980-5M-450SL	450	3.9
1000-5M-450SL	450	4.0
1025-5M-450SL	450	4.1
1050-5M-450SL	450	4.2
1100-5M-450SL	450	4.4
1115-5M-450SL	450	4.5
1125-5M-450SL	450	4.5
1145-5M-450SL	450	4.6
1175-5M-450SL	450	4.7
1180-5M-450SL	450	4.7
1195-5M-450SL	450	4.8
1200-5M-450SL	450	4.8
1210-5M-450SL	450	4.9
1250-5M-450SL	450	5.0
1270-5M-450SL	450	5.1
1290-5M-450SL	450	5.2
1295-5M-450SL	450	5.2
1300-5M-450SL	450	5.2
1340-5M-450SL	450	5.4
1350-5M-450SL	450	5.4
1375-5M-450SL	450	5.5
1420-5M-450SL	450	5.7
1450-5M-450SL	450	5.8
1500-5M-450SL	450	6.0
1595-5M-450SL	450	6.4

Part Number	Sleeve Width (mm)	Sleeve Weight (lbs)
5M Pitch – High Torque Synchronous (HTS) Sprockets: MPB, QD, Taper Bushed (5mm)		
1600-5M-450SL	450	6.4
1685-5M-450SL	450	6.8
1690-5M-450SL	450	6.8
1790-5M-450SL	450	7.2
1800-5M-450SL	450	7.2
1895-5M-440SL	440	7.5
2000-5M-450SL	450	8.0
2100-5M-450SL	450	8.4
2350-5M-450SL	450	9.5
2525-5M-450SL	450	10.2
2635-5M-450SL	450	10.6
4260-5M-440SL	440	16.8
288-8M-450SL	450	1.7
8M Pitch – High Torque Synchronous (HTS) Sprockets: MPB, QD, Taper Bushed (8mm)		
320-8M-450SL	450	1.7
368-8M-450SL	450	2.0
400-8M-450SL	450	2.2
408-8M-450SL	450	2.2
424-8M-450SL	450	2.3
440-8M-450SL	450	2.4
448-8M-450SL	450	2.4
480-8M-450SL	450	2.6
512-8M-450SL	450	2.8
520-8M-450SL	450	2.8
536-8M-450SL	450	2.9
544-8M-450SL	450	3.0
560-8M-450SL	450	3.0
568-8M-450SL	450	3.1
576-8M-450SL	450	3.1
584-8M-450SL	450	3.2
592-8M-450SL	450	3.2
600-8M-450SL	450	3.3

Synchro-Cog® HT

Sleeves

Synchro-Cog® HT Sleeve Part Numbers

Part Number	Sleeve Width (mm)	Sleeve Weight (lbs)
8M Pitch – High Torque Synchronous (HTS) Sprockets: MPB, OD, Taper Bushed (8mm)		
608-8M-450SL	450	3.3
624-8M-450SL	450	3.4
632-8M-450SL	450	3.4
640-8M-450SL	450	3.5
648-8M-450SL	450	3.5
656-8M-450SL	450	3.6
680-8M-450SL	450	3.7
688-8M-450SL	450	3.7
696-8M-450SL	450	3.8
712-8M-450SL	450	3.9
720-8M-450SL	450	3.9
760-8M-450SL	450	4.1
768-8M-450SL	450	4.2
776-8M-450SL	450	4.2
784-8M-450SL	450	4.3
792-8M-450SL	450	4.3
800-8M-450SL	450	4.3
816-8M-450SL	450	4.4
824-8M-450SL	450	4.5
840-8M-450SL	450	4.6
848-8M-450SL	450	4.6
856-8M-450SL	450	4.7
864-8M-450SL	450	4.7
880-8M-450SL	450	4.8
896-8M-450SL	450	4.9
912-8M-450SL	450	5.0
920-8M-450SL	450	5.0
928-8M-450SL	450	5.0
936-8M-450SL	450	5.1
944-8M-450SL	450	5.1
952-8M-450SL	450	5.2
960-8M-450SL	450	5.2
968-8M-450SL	450	5.3

Part Number	Sleeve Width (mm)	Sleeve Weight (lbs)
8M Pitch – High Torque Synchronous (HTS) Sprockets: MPB, OD, Taper Bushed (8mm)		
976-8M-450SL	450	5.3
1000-8M-450SL	450	5.4
1016-8M-450SL	450	5.5
1024-8M-450SL	450	5.6
1040-8M-450SL	450	5.7
1056-8M-450SL	450	5.7
1064-8M-450SL	450	5.8
1080-8M-450SL	450	5.9
1104-8M-450SL	450	6.0
1120-8M-450SL	450	6.1
1128-8M-450SL	450	6.1
1136-8M-450SL	450	6.2
1152-8M-450SL	450	6.3
1160-8M-450SL	450	6.3
1168-8M-450SL	450	6.3
1184-8M-450SL	450	6.4
1200-8M-450SL	450	6.5
1208-8M-450SL	450	6.6
1216-8M-450SL	450	6.6
1224-8M-450SL	450	6.7
1240-8M-450SL	450	6.7
1248-8M-450SL	450	6.8
1256-8M-450SL	450	6.8
1264-8M-450SL	450	6.9
1272-8M-450SL	450	6.9
1280-8M-450SL	450	7.0
1304-8M-450SL	450	7.1
1312-8M-450SL	450	7.1
1320-8M-450SL	450	7.2
1328-8M-450SL	450	7.2
1344-8M-450SL	450	7.3
1352-8M-450SL	450	7.3
1360-8M-450SL	450	7.4

Synchro-Cog® HT Sleeves

Part Number Example: **1600-8M-440SL** = **1600** - **8M** - **440** **SL**
Pitch Length (millimeters) Tooth Pitch (HTD profile) Width (millimeters) Sleeve

Part Number	Sleeve Width (mm)	Sleeve Weight (lbs)
8M Pitch – High Torque Synchronous (HTS) Sprockets: MPB, QD, Taper Bushed (8mm)		
1376-8M-450SL	450	7.5
1392-8M-450SL	450	7.6
1400-8M-440SL	440	7.4
1424-8M-440SL	440	7.6
1440-8M-440SL	440	7.7
1456-8M-440SL	440	7.7
1464-8M-440SL	440	7.8
1480-8M-440SL	440	7.9
1512-8M-440SL	440	8.0
1520-8M-440SL	440	8.1
1552-8M-440SL	440	8.2
1560-8M-440SL	440	8.3
1576-8M-440SL	440	8.4
1584-8M-440SL	440	8.4
1600-8M-440SL	440	8.5
1640-8M-440SL	440	8.7
1648-8M-440SL	440	8.8
1680-8M-440SL	440	8.9
1696-8M-400SL	400	8.2
1728-8M-440SL	440	9.2
1744-8M-440SL	440	9.3
1752-8M-440SL	440	9.3
1760-8M-440SL	440	9.4
1784-8M-440SL	440	9.5
1792-8M-440SL	440	9.5
1800-8M-440SL	440	9.6
1840-8M-440SL	440	9.8
1856-8M-440SL	440	9.9
1896-8M-440SL	440	10.1
1904-8M-440SL	440	10.1
1920-8M-440SL	440	10.2
1928-8M-440SL	440	10.2
1936-8M-440SL	440	10.3

Part Number	Sleeve Width (mm)	Sleeve Weight (lbs)
8M Pitch – High Torque Synchronous (HTS) Sprockets: MPB, QD, Taper Bushed (8mm)		
1952-8M-440SL	440	10.4
1992-8M-440SL	440	10.6
2000-8M-440SL	440	10.6
2056-8M-440SL	440	10.9
2080-8M-440SL	440	11.1
2104-8M-440SL	440	11.2
2136-8M-440SL	440	11.4
2160-8M-440SL	440	11.5
2208-8M-440SL	440	11.7
2240-8M-440SL	440	11.9
2272-8M-440SL	440	12.1
2304-8M-440SL	440	12.2
2328-8M-440SL	440	12.4
2392-8M-440SL	440	12.7
2400-8M-440SL	440	12.8
2504-8M-440SL	440	13.3
2584-8M-440SL	440	13.7
2600-8M-440SL	440	13.8
2656-8M-440SL	440	14.1
2736-8M-440SL	440	14.5
2800-8M-440SL	440	14.9
3048-8M-440SL	440	16.2
3120-8M-440SL	440	16.6
3168-8M-440SL	440	16.8
3200-8M-440SL	440	17.0
3280-8M-440SL	440	17.4
3400-8M-440SL	440	18.1
3600-8M-440SL	440	19.1
3824-8M-440SL	440	20.3
4000-8M-440SL	440	21.3
4400-8M-180SL	180	9.6
5120-8M-240SL	240	14.8
5576-8M-440SL	440	29.6

Synchro-Cog® HT

Sleeves

Synchro-Cog® HT Sleeve Part Numbers

Part Number Example: **1400-14M-440SL** = **1400** - **14M** - **440** **SL**
Pitch Length (millimeters) Tooth Pitch (HTD profile) Width (millimeters) Sleeve

Part Number	Sleeve Width (mm)	Sleeve Weight (lbs)
8M Pitch – High Torque Synchronous (HTS) Sprockets: MPB, OD, Taper Bushed (8mm)		
5600-8M-440SL	440	29.8
5960-8M-240SL	240	17.3
14M Pitch – High Torque Synchronous (HTS) Sprockets: MPB, OD, Taper Bushed (14mm)		
966-14M-440SL	440	8.3
1036-14M-440SL	440	8.9
1092-14M-440SL	440	9.4
1120-14M-440SL	440	9.7
1148-14M-440SL	440	9.9
1190-14M-440SL	440	10.3
1246-14M-440SL	440	10.7
1260-14M-440SL	440	10.9
1288-14M-440SL	440	11.0
1316-14M-440SL	440	11.3
1344-14M-440SL	440	11.6
1400-14M-440SL	440	12.1
1442-14M-440SL	440	12.4
1456-14M-440SL	440	12.5
1470-14M-440SL	440	12.7
1540-14M-440SL	440	13.3
1568-14M-440SL	440	13.5
1610-14M-440SL	440	13.9
1652-14M-440SL	440	14.2
1750-14M-440SL	440	15.1
1764-14M-440SL	440	15.2
1778-14M-440SL	440	15.3
1792-14M-440SL	440	15.4
1806-14M-440SL	440	15.6
1820-14M-440SL	440	15.7
1890-14M-440SL	440	16.3
1932-14M-440SL	440	16.6
1960-14M-440SL	440	16.9
2100-14M-440SL	440	18.1

Part Number	Sleeve Width (mm)	Sleeve Weight (lbs)
14M Pitch – High Torque Synchronous (HTS) Sprockets: MPB, OD, Taper Bushed (14mm)		
2240-14M-440SL	440	19.3
2310-14M-440SL	440	19.9
2450-14M-440SL	440	21.1
2590-14M-440SL	440	22.3
2660-14M-440SL	440	22.9
2800-14M-440SL	440	24.1
3108-14M-430SL	430	26.2
3150-14M-430SL	430	26.5
3304-14M-430SL	430	27.8
3360-14M-430SL	430	28.3
3500-14M-430SL	430	29.5
3668-14M-430SL	430	30.9
3850-14M-430SL	430	32.4
4326-14M-350SL	350	29.6
4536-14M-430SL	430	38.2
4578-14M-230SL	230	20.6
4956-14M-430SL	430	41.7
5320-14M-430SL	430	44.8
5740-14M-430SL	430	48.3
6160-14M-430SL	430	51.9
6860-14M-430SL	430	57.8

Dual RPP® Synchronous Drive Belt

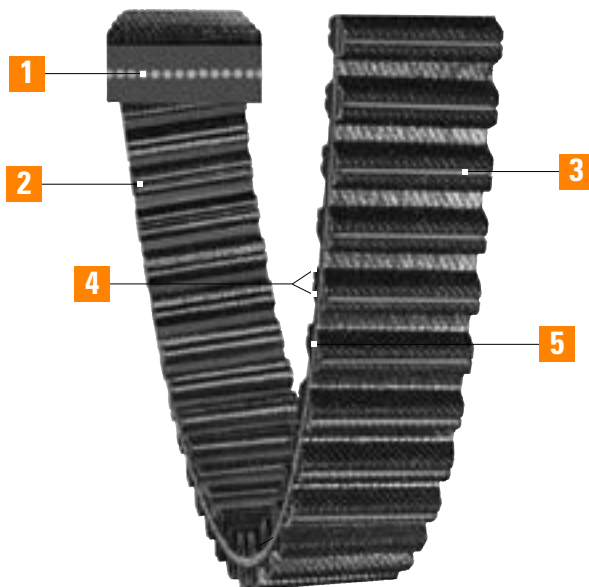

1 Ultra-Cord® Tensile Member
High strength
Low tension decay
Dimensional stability

2 Nylon Tooth Facing
Graphite-loaded
Self-lubricating
Wear resistant

3 RPP® Profile
Efficient transfer of power
Jump and shear resistant
Quiet

4 Load Capacity
100% on both side of the belt

5 Advanced Polymer Compound
Excellent performance
Long belt life

Recommended Sprockets:
High Torque Synchronous Sprockets – MPB, OD, Taper Bushed (8mm, 14mm)

Superior performance

Smaller, more compact system

Reduced drive weight and space

100% load capacity on both sides

Applications:

- Printing presses
- Mixers
- Agitators
- Machine tools
- Robotics
- Sewing machines
- Vending machines
- & More

Dual RPP®

Synchronous Drive Belt

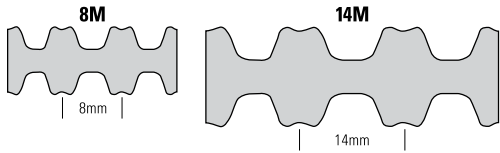

Proven performance from both sides of the belt for greater flexibility and efficiency in your drive design.

The Dual RPP® Synchronous Belt yields proven performance in a double sided curvilinear design providing maintenance-free synchronization that delivers 100% load capacity from both sides of the belt.

Molded teeth with RPP profile provide excellent resistance to tooth jump and shear.

The manufacturing process allows for equal load capacity on both sides of the belt, a feature not found in many dual sided belts on the market. Achieve greater drive design flexibility and efficiency with Timken Dual RPP Synchronous belts.

Choose Dual Synchronous Belts for a compact, efficient, quiet, and smooth running drive.

Available in 8M and 14M tooth profiles

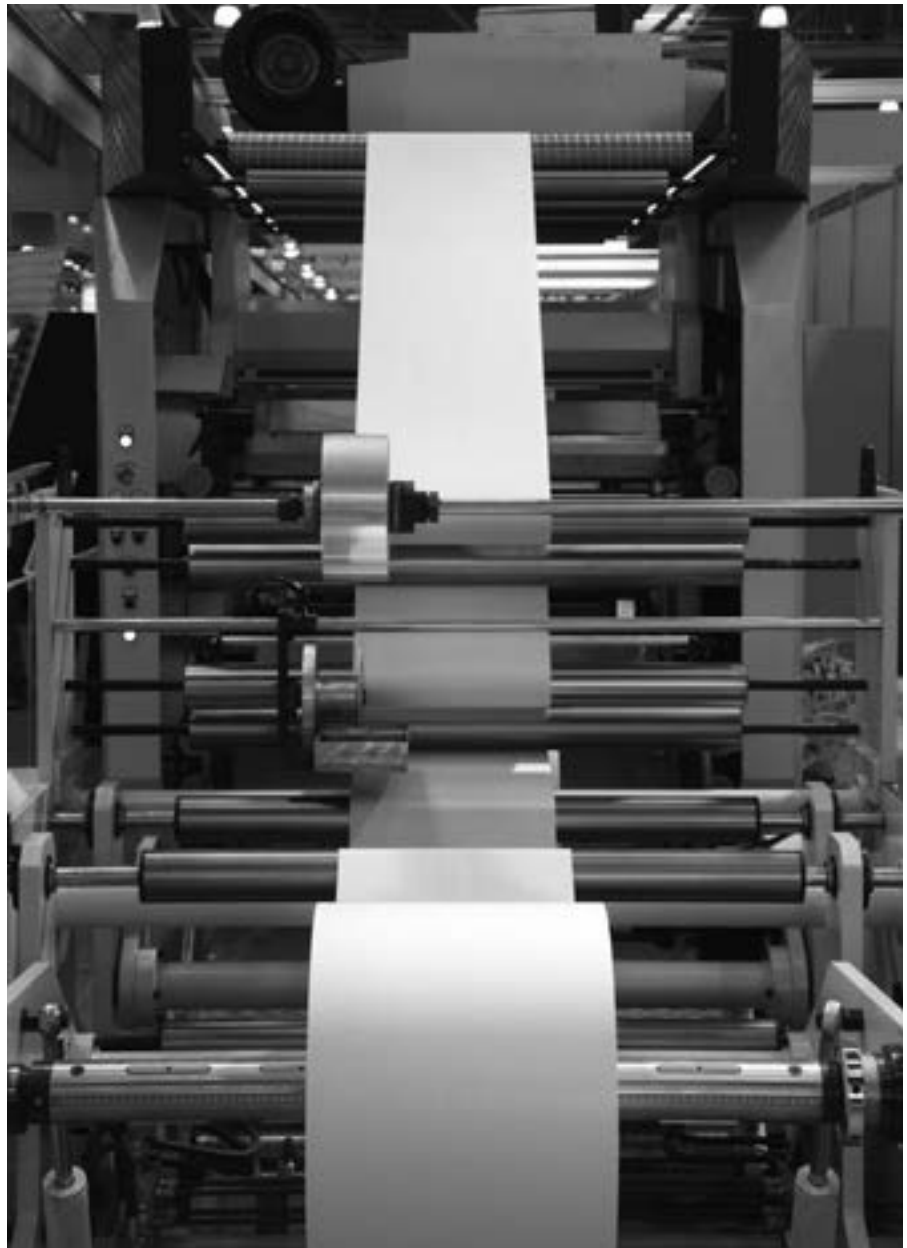
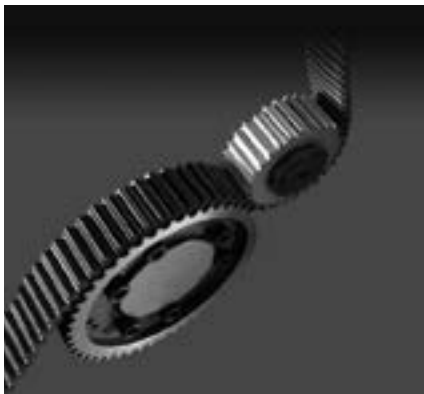

Dual RPP® Synchronous Drive Belt

Dual RPP Synchronous Part Numbers

Part Number	Number Of Teeth	Pitch Length		Weight (lbs)
		(mm)	(in)	
8M Pitch – High Torque Synchronous (HTS) Sprockets: MPB, QD, Taper Bushed (8mm)				
D720-8M-20	90	720	28.00	0.2
D720-8M-30	90	720	28.00	0.3
D720-8M-50	90	720	28.00	0.6
D720-8M-85	90	720	28.00	1.0
D800-8M-15	100	800	32.00	0.2
D800-8M-20	100	800	32.00	0.3
D800-8M-30	100	800	32.00	0.4
D800-8M-50	100	800	32.00	0.6
D800-8M-85	100	800	32.00	1.1
D840-8M-20	105	840	33.00	0.3
D840-8M-30	105	840	33.00	0.4
D840-8M-50	105	840	33.00	0.7
D840-8M-85	105	840	33.00	1.1
D880-8M-20	110	880	35.00	0.3
D880-8M-30	110	880	35.00	0.4
D880-8M-50	110	880	35.00	0.7
D880-8M-85	110	880	35.00	1.2
D920-8M-20	115	920	36.20	0.3
D920-8M-30	115	920	36.20	0.4
D920-8M-50	115	920	36.20	0.7
D920-8M-85	115	920	36.20	1.3
D960-8M-20	120	960	38.00	0.3
D960-8M-30	120	960	38.00	0.5
D960-8M-50	120	960	38.00	0.8
D960-8M-85	120	960	38.00	1.3
D1040-8M-20	130	1040	41	0.3
D1040-8M-30	130	1040	41	0.5
D1040-8M-50	130	1040	41	0.8
D1040-8M-85	130	1040	41	1.4
D1120-8M-12	140	1120	44	0.2
D1120-8M-15	140	1120	44	0.2
D1120-8M-20	140	1120	44	0.4
D1120-8M-30	140	1120	44	0.5

Part Number Example: **D1200-8M-50** =

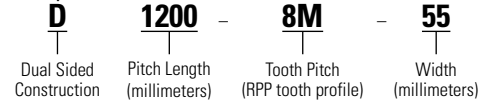

Part Number	Number Of Teeth	Pitch Length		Weight (lbs)
		(mm)	(in)	
8M Pitch – High Torque Synchronous (HTS) Sprockets: MPB, QD, Taper Bushed (8mm)				
D1120-8M-50	140	1120	44	0.9
D1120-8M-85	140	1120	44	1.5
D1200-8M-20	150	1200	47	0.4
D1200-8M-30	150	1200	47	0.6
D1200-8M-50	150	1200	47	1.0
D1200-8M-85	150	1200	47	1.6
D1224-8M-20	153	1224	48	0.4
D1224-8M-30	153	1224	48	0.6
D1224-8M-50	153	1224	48	1.0
D1224-8M-85	153	1224	48	1.7
D1280-8M-20	160	1280	50	0.4
D1280-8M-30	160	1280	50	0.6
D1280-8M-50	160	1280	50	1.0
D1280-8M-85	160	1280	50	1.7
D1440-8M-16.5	180	1440	57	0.4
D1440-8M-20	180	1440	57	0.5
D1440-8M-30	180	1440	57	0.7
D1440-8M-40	180	1440	57	1.7
D1440-8M-50	180	1440	57	1.2
D1440-8M-85	180	1440	57	2.0
D1600-8M-20	200	1600	63	0.5
D1600-8M-30	200	1600	63	0.6
D1600-8M-35	200	1600	63	0.7
D1600-8M-43	200	1600	63	0.8
D1600-8M-50	200	1600	63	1.3
D1600-8M-85	200	1600	63	2.2
D1760-8M-20	220	1760	69	0.6
D1760-8M-30	220	1760	69	0.8
D1760-8M-50	220	1760	69	1.4
D1760-8M-85	220	1760	69	2.4
D1760-8M-170	220	1760	69	2.5
D1800-8M-16	225	1800	71	0.6
D1800-8M-20	225	1800	71	0.7

Dual RPP®

Synchronous Drive Belt

Dual RPP Synchronous Part Numbers

Part Number	Number Of Teeth	Pitch Length		Weight (lbs)
		(mm)	(in)	
8M Pitch – High Torque Synchronous (HTS) Sprockets: MPB, OD, Taper Bushed (8mm)				
D1800-8M-25	225	1800	71	1.0
D1800-8M-30	225	1800	71	1.1
D1800-8M-32	225	1800	71	1.2
D1800-8M-42.5	225	1800	71	1.3
D1800-8M-50	225	1800	71	1.4
D1800-8M-85	225	1800	71	1.5
D2000-8M-16	250	2000	79	0.6
D2000-8M-19	250	2000	79	0.6
D2000-8M-20	250	2000	79	0.6
D2000-8M-30	250	2000	79	1.0
D2000-8M-50	250	2000	79	1.6
D2000-8M-85	250	2000	79	2.7
D2200-8M-15	275	2200	87	0.5
D2200-8M-20	275	2200	87	0.7
D2200-8M-30	275	2200	87	1.1
D2200-8M-50	275	2200	87	1.8
D2200-8M-85	275	2200	87	3.0
D2400-8M-20	300	2400	94	0.8
D2400-8M-30	300	2400	94	1.2
D2400-8M-50	300	2400	94	1.9
D2400-8M-85	300	2400	94	3.3
D2600-8M-20	325	2600	102	0.8
D2600-8M-30	325	2600	102	1.3
D2600-8M-35	325	2600	102	1.5
D2600-8M-50	325	2600	102	2.1
D2600-8M-85	325	2600	102	3.5
D2800-8M-20	350	2800	110	0.9
D2800-8M-30	350	2800	110	1.3
D2800-8M-50	350	2800	110	2.2
D2800-8M-85	350	2800	110	3.8
D3048-8M-20	381	3048	120	1.0
D3048-8M-30	381	3048	120	1.5
D3048-8M-50	381	3048	120	2.4

Part Number	Number Of Teeth	Pitch Length		Weight (lbs)
		(mm)	(in)	
8M Pitch – High Torque Synchronous (HTS) Sprockets: MPB, OD, Taper Bushed (8mm)				
D3048-8M-85	381	3048	120	4.2
D3280-8M-20	410	3280	129	1.1
D3280-8M-30	410	3280	129	1.6
D3280-8M-50	410	3280	129	2.6
D3280-8M-85	410	3280	129	4.5
D3600-8M-20	450	3600	142	1.2
D3600-8M-30	450	3600	142	1.7
D3600-8M-35	450	3600	142	1.9
D3600-8M-50	450	3600	142	2.9
D3600-8M-85	450	3600	142	4.9
D4400-8M-20	550	4400	173	1.4
D4400-8M-30	550	4400	173	2.1
D4400-8M-50	550	4400	173	3.5
D4400-8M-85	550	4400	173	6.0
14M Pitch – High Torque Synchronous Sprockets: MPB, OD, Taper Bushed (14mm)				
D966-14M-40	69	966	38	1.0
D966-14M-55	69	966	38	1.4
D966-14M-85	69	966	38	2.1
D966-14M-115	69	966	38	2.9
D966-14M-170	69	966	38	4.2
D1190-14M-35	85	1190	47	1.1
D1190-14M-40	85	1190	47	1.2
D1190-14M-55	85	1190	47	1.7
D1190-14M-85	85	1190	47	2.6
D1190-14M-115	85	1190	47	3.5
D1190-14M-170	85	1190	47	5.2
D1400-14M-35	100	1400	55	1.3
D1400-14M-40	100	1400	55	1.4
D1400-14M-55	100	1400	55	2.0
D1400-14M-85	100	1400	55	3.1
D1400-14M-115	100	1400	55	4.1
D1400-14M-170	100	1400	55	6.1

Dual RPP® Synchronous Drive Belt

Part Number Example: **D2400-8M-50** =

D **2400** **8M** **50**
 Dual Sided Pitch Length Tooth Pitch Width
 Construction (millimeters) (RPP tooth profile) (millimeters)

Part Number	Number Of Teeth	Pitch Length		Weight (lbs)
		(mm)	(in)	
14M Pitch – High Torque Synchronous (HTS) Sprockets: MPB, QD, Taper Bushed (14mm)				
D1610-14M-40	115	1610	63	1.7
D1610-14M-55	115	1610	63	2.3
D1610-14M-85	115	1610	63	3.5
D1610-14M-115	115	1610	63	4.8
D1610-14M-170	115	1610	63	7.0
D1764-14M-40	126	1764	69	1.8
D1778-14M-25	127	1778	70	1.1
D1778-14M-30	127	1778	70	1.4
D1778-14M-40	127	1778	70	1.8
D1778-14M-55	127	1778	70	2.5
D1778-14M-85	127	1778	70	3.9
D1778-14M-115	127	1778	70	5.3
D1778-14M-170	127	1778	70	7.8
D1890-14M-30	135	1890	74	1.5
D1890-14M-40	135	1890	74	1.9
D1890-14M-55	135	1890	74	2.7
D1890-14M-85	135	1890	74	4.1
D1890-14M-115	135	1890	74	5.6
D1890-14M-120	135	1890	74	6.6
D1890-14M-170	135	1890	74	8.3
D2100-14M-30	150	2100	83	2.0
D2100-14M-40	150	2100	83	2.2
D2100-14M-55	150	2100	83	3.0
D2100-14M-75	150	2100	83	4.5
D2100-14M-85	150	2100	83	4.6
D2100-14M-115	150	2100	83	6.2
D2100-14M-170	150	2100	83	9.2
D2310-14M-40	165	2310	91	2.4
D2310-14M-55	165	2310	91	3.3
D2310-14M-85	165	2310	91	5.0
D2310-14M-115	165	2310	91	6.8
D2310-14M-170	165	2310	91	10.1
D2450-14M-40	175	2450	96	2.5

Part Number	Number Of Teeth	Pitch Length		Weight (lbs)
		(mm)	(in)	
14M Pitch – High Torque Synchronous (HTS) Sprockets: MPB, QD, Taper Bushed (14mm)				
D2450-14M-55	175	2450	96	3.5
D2450-14M-85	175	2450	96	5.4
D2450-14M-115	175	2450	96	7.2
D2450-14M-170	175	2450	96	10.7
D2590-14M-40	185	2590	102	2.7
D2590-14M-55	185	2590	102	3.7
D2590-14M-85	185	2590	102	5.7
D2590-14M-115	185	2590	102	7.7
D2590-14M-170	185	2590	102	11.3
D2800-14M-40	200	2800	110	2.9
D2800-14M-55	200	2800	110	4.0
D2800-14M-85	200	2800	110	6.1
D2800-14M-100	200	2800	110	6.8
D2800-14M-115	200	2800	110	8.3
D2800-14M-170	200	3150	110	12.2
D3150-14M-40	225	3150	124	3.2
D3150-14M-55	225	3150	124	4.5
D3150-14M-85	225	3150	124	6.9
D3150-14M-115	225	3150	124	9.3
D3150-14M-170	225	3360	124	13.8
D3360-14M-40	240	3360	132	3.5
D3360-14M-55	240	3360	132	4.8
D3360-14M-85	240	3360	132	7.3
D3360-14M-115	240	3360	132	9.9
D3360-14M-170	240	3360	132	14.7
D3500-14M-20	250	3500	138	2.1
D3500-14M-40	250	3500	138	3.6
D3500-14M-55	250	3500	138	4.9
D3500-14M-68	250	3500	138	5.2
D3500-14M-85	250	3500	138	7.6
D3500-14M-115	250	3500	138	10.3
D3500-14M-170	250	3500	138	15.3
D3850-14M-40	275	3850	152	4.0

Dual RPP®

Synchronous Drive Belt

Dual RPP Synchronous Part Numbers

Part Number	Number Of Teeth	Pitch Length		Weight (lbs)
		(mm)	(in)	
14M Pitch – High Torque Synchronous (HTS) Sprockets: MPB, OD, Taper Bushed (14mm)				
D3850-14M-55	275	3850	152	5.4
D3850-14M-85	275	3850	152	8.4
D3850-14M-90	275	3850	152	11.2
D3850-14M-115	275	3850	152	11.4
D3850-14M-170	275	3850	152	16.8
D4326-14M-40	309	4326	170	4.4
D4326-14M-55	309	4326	170	6.1
D4326-14M-85	309	4326	170	9.5
D4326-14M-115	309	4326	170	12.8
D4326-14M-170	309	4326	170	18.9
D4578-14M-40	327	4578	180	0.5
D4578-14M-55	327	4578	180	6.5
D4578-14M-85	327	4578	180	10.0
D4578-14M-115	327	4578	180	13.5
D4578-14M-170	327	4578	180	20.0
D4956-14M-40	354	4956	195	5.1
D4956-14M-55	354	4956	195	7.0
D4956-14M-85	354	4956	195	10.8
D4956-14M-115	354	4956	195	14.7
D4956-14M-170	354	4956	195	21.7
D5320-14M-40	380	5320	209	6.1
D5320-14M-55	380	5320	209	7.5
D5320-14M-85	380	5320	209	11.6
D5320-14M-115	380	5320	209	15.7

Dual RPP® Synchronous Sleeves



- Full factory width sleeves
- Sleeve edges are trimmed before shipment
- Sleeves cannot be accepted for return

Timken maintains inventory of most sleeve sizes. Contact customer service for availability. Minimum order quantity and/or extended lead times may apply.

Occasional production inconsistencies which may render a portion of the sleeve unusable can be present as a normal part of the production process.

Each sleeve is inspected to ensure that it contains 90% or more usable product. A full width sleeve with less than 10% unusable product is considered acceptable.



Dual RPP Synchronous Sleeve Part Numbers

Part Number	Sleeve Width (mm)	Sleeve Weight (lbs)
8M Pitch – High Torque Synchronous (HTS) Sprockets: MPB, QD, Taper Bushed (8mm)		
D720-8M-150SL	150	1.7
D800-8M-150SL	150	1.9
D840-8M-150SL	150	2.0
D880-8M-150SL	150	2.1
D920-8M-150SL	150	2.2
D960-8M-215SL	215	3.3
D1040-8M-215SL	215	3.6
D1120-8M-215SL	215	3.9
D1200-8M-215SL	215	4.1
D1224-8M-150SL	150	4.2
D1280-8M-215SL	215	4.4
D1440-8M-215SL	215	5.0
D1600-8M-215SL	215	5.5
D1760-8M-215SL	215	6.0
D1800-8M-215SL	215	6.2
D2000-8M-215SL	215	6.9
D2200-8M-215SL	215	7.6
D2400-8M-215SL	215	8.3
D2600-8M-215SL	215	9.0
D2800-8M-215SL	215	9.7
D3048-8M-215SL	215	10.5
D3280-8M-215SL	215	11.3
D3600-8M-215SL	215	12.4
D4400-8M-215SL	215	15.2

Dual RPP® Synchronous Sleeves

Dual Synchronous Sleeve Part Numbers

Part Number Example: **D1200-8M-215SL**

D	1200	-	8M	-	215	SL
Dual Sided Construction	Pitch Length (millimeters)		Tooth Pitch (RPP tooth profile)		Width (millimeters)	Sleeve

Part Number	Sleeve Width (mm)	Sleeve Weight (lbs)
14M Pitch – High Torque Synchronous (HTS) Sprockets: MPB, OD, Taper Bushed (14mm)		
D966-14M-170SL	170	4.2
D1190-14M-170SL	170	5.2
D1400-14M-215SL	215	7.7
D1610-14M-215SL	215	8.9
D1778-14M-215SL	215	9.8
D1890-14M-215SL	215	10.5
D2100-14M-215SL	215	11.6
D2310-14M-215SL	215	12.8
D2450-14M-215SL	215	13.5
D2590-14M-215SL	215	14.3
D2800-14M-215SL	215	15.5
D3150-14M-215SL	215	17.4
D3360-14M-215SL	215	18.6
D3500-14M-215SL	215	19.3
D3850-14M-215SL	215	21.3
D4326-14M-215SL	215	23.9
D4578-14M-215SL	215	25.3
D4956-14M-215SL	215	27.4

Air-Cooled Heat Exchanger (ACHE) Synchronous Drive Belt

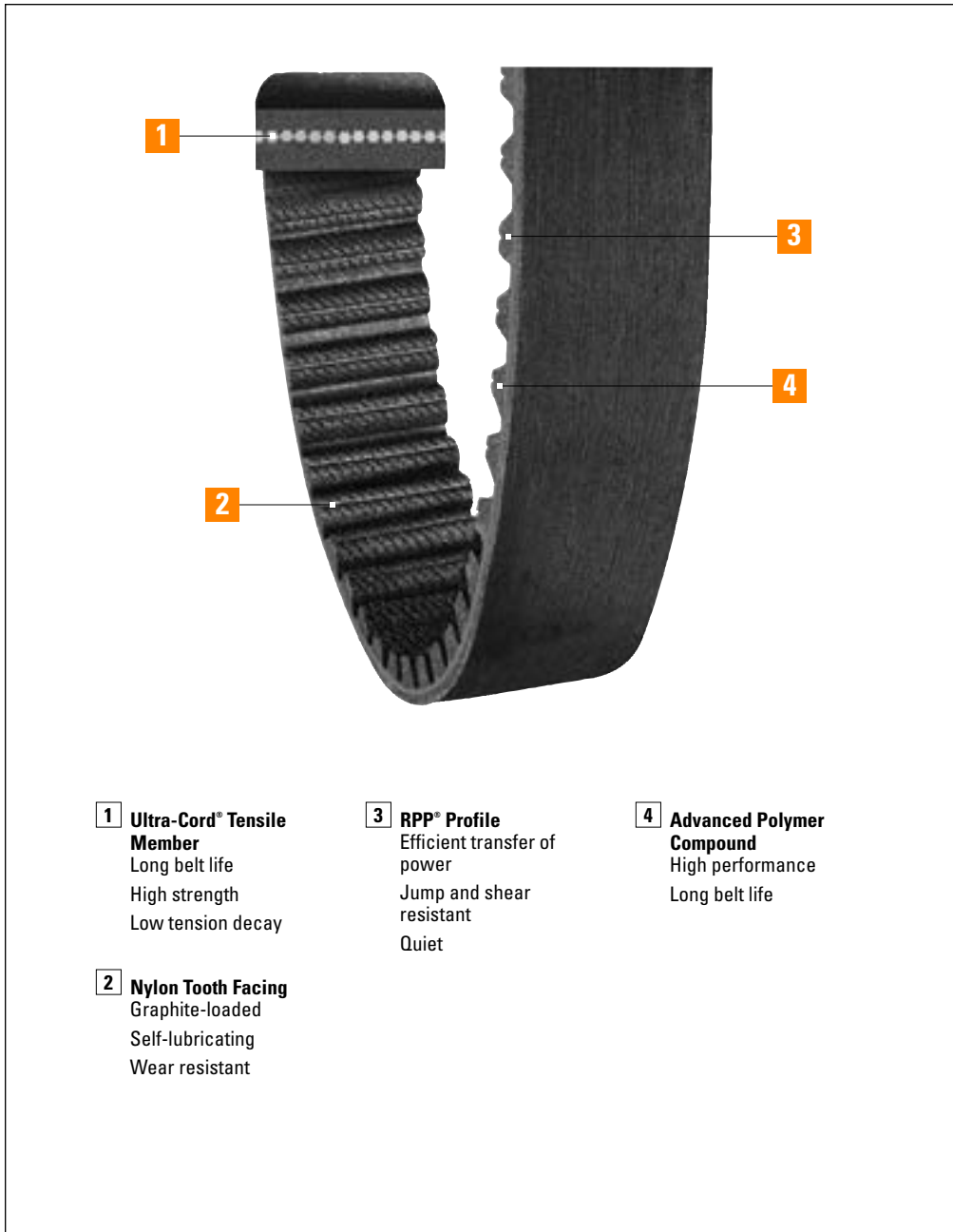

1 Ultra-Cord® Tensile Member
Long belt life
High strength
Low tension decay

2 Nylon Tooth Facing
Graphite-loaded
Self-lubricating
Wear resistant

3 RPP® Profile
Efficient transfer of power
Jump and shear resistant
Quiet

4 Advanced Polymer Compound
High performance
Long belt life

Recommended Sprockets:
High Torque Synchronous Sprockets – MPB, OD, Taper Bushed (14mm)

Special “Z” twist construction for air-cooled heat exchangers

Using “Z” twist cord only provides an upward direction of lateral movement which helps keep the belt off of the bottom flanges, reducing excessive wear on the bottom side of the belt

Applications:
Air-cooled heat exchangers

Air-Cooled Heat Exchanger (ACHE)

Synchronous Drive Belt

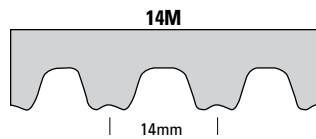

Special "Z" twist cord construction for air-cooled heat exchanger applications.

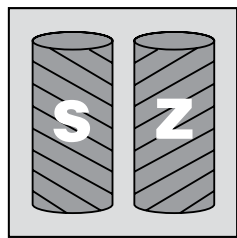

Timken ACHE (Air-Cooled Heat Exchanger) synchronous belts are manufactured using a special construction. Because the drive has a vertical shaft, the belt is built with "Z" twist cords only.

This gives the belt an upward direction of lateral movement which reduces excessive wear on the bottom side of the belt.

The cord in a synchronous belt is made up of a number of small fiber strands twisted together. These strands can be twisted either clockwise or counterclockwise. The two twist directions are referred to as "S" twist and "Z" twist. To reduce lateral movement, most synchronous belts are constructed by alternately spiraling "S" and "Z" type cords. Timken ACHE belts use only "Z" twist cords to predetermine the lateral movement of the belt.

Part Number Example: **3150-14M-55F =**

3150 - **1400** - **55** - **F**
 Pitch Length (millimeters) Tooth Pitch (RPP tooth profile) Width (millimeters) Z-Twist Cord Construction

Air-Cooled Heat Exchanger Belt Part Numbers

Note: Air-Cooled Heat Exchanger belts can be cut to different widths as needed

Part Number	Number of Teeth	Pitch Length (mm)	Pitch Length (inches)	Weight (lbs.)
14M Pitch – High Torque Synchronous (HTS) Sprockets: MPB, QD, Taper Bushed (14mm)				
2800-14M-55F	200	2800	110.2	3.1
2800-14M-85F	200	2800	110.2	4.8
3150-14M-55F	225	3150	124.0	3.5
3150-14M-85F	225	3150	124.0	5.4
3360-14M-42F	240	3360	132.6	2.8
3360-14M-55F	240	3360	132.6	3.7
3360-14M-85F	240	3360	132.6	5.7
3500-14M-25F	250	3500	137.8	1.8
3500-14M-37F	250	3500	137.8	2.6
3500-14M-40F	250	3500	137.8	2.8
3500-14M-55F	250	3500	137.8	3.9
3500-14M-85F	250	3500	137.8	6.0
3850-14M-30F	275	3850	151.6	2.3
3850-14M-40F	275	3850	151.6	3.1
3850-14M-55F	275	3850	151.6	4.2
3850-14M-85F	275	3850	151.6	6.6
4326-14M-40F	309	4326	170.3	3.5
4326-14M-55F	309	4326	170.3	4.8
4326-14M-85F	309	4326	170.3	7.4

Air-Cooled Heat Exchanger (ACHE) Sleeves



- Full factory width sleeves
- Sleeve edges are trimmed before shipment
- Sleeves cannot be accepted for return

Timken Belts maintains inventory of most sleeve sizes. Contact customer service for availability. Minimum order quantity and/or extended lead times may apply.

Occasional production inconsistencies which may render a portion of the sleeve unusable can be present as a normal part of the production process.

Each sleeve is inspected to ensure that it contains 90% or more usable product. A full width sleeve with less than 10% unusable product is considered acceptable.



Part Number Example: **3150-14M-570SF =**

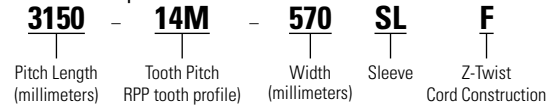

Air-Cooled Heat Exchanger Sleeve Part Numbers

Part Number	Top Width (mm)	Sleeve Weight (lbs)
14M Pitch – High Torque Synchronous (HTS) Sprockets: MPB, QD, Taper Bushed (14mm)		
2800-14M-570SLF	570	32.0
3150-14M-570SLF	570	36.0
3360-14M-570SLF	570	38.4
3500-14M-570SLF	570	40.0
3850-14M-570SLF	570	44.0
4326-14M-570SLF	570	49.4

Synchro-Cog® Timing Belt

Synchronous Drive Belt



Synchro-Cog® Timing Belt

Synchronous Drive Belt

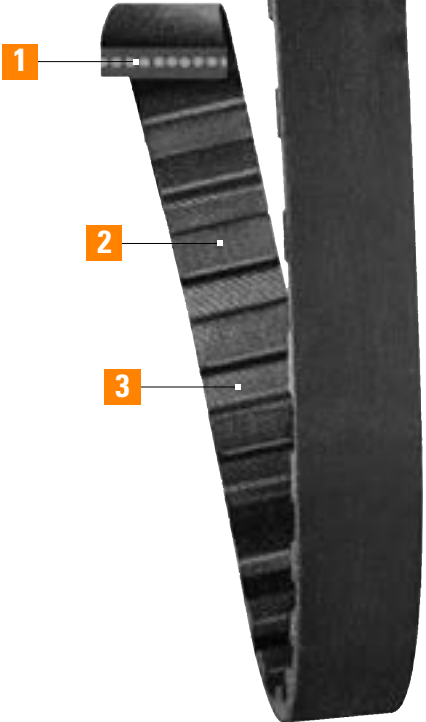

1 Tensile Cord
Specially treated to provide strength, added flex life and resistance to stretching.

2 Molded Teeth
Shear resistant. Designed to assure smooth, positive meshing with the sprocket.

3 Tooth Fabric
Provides maximum flexibility and wear resistance for extended belt life.

Recommended Pulleys:
Timing Pulleys – MPB, QD, Taper Bushed (XL, L, H, XH, XXH)

Trapezoidal tooth profile

Synchronization
between driver and
driven units

Low maintenance

Long life

Clean and quiet

Applications:

- Machine tools
- Sewing machines
- Packaging equipment
- Vending machines
- Food processing
equipment
- & More

Synchro-Cog® Timing Belt

Synchronous Drive Belt

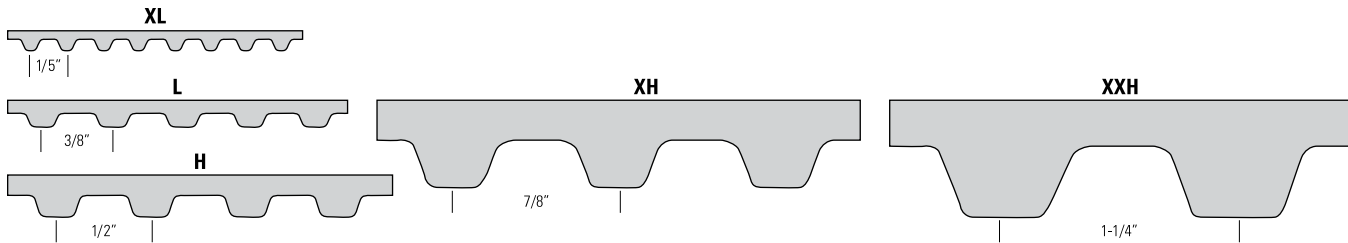

The Synchro-Cog® Timing Belt has a trapezoidal tooth profile for applications where synchronization between the driving and driven units is required.

The first synchronous belts had a trapezoidal tooth profile and are often called timing belts. Use a Synchro-Cog® timing belt for energy efficient, low maintenance performance on traditional positive drive applications.

Synchro-Cog timing belts provide a wide range of load capacities and speeds. Belts are oil, heat, and abrasion resistant. Molded teeth are sheer resistant and designed to assure smooth, positive meshing with the sprocket. A tough nylon tooth facing is wear resistant. High quality fiberglass cords are specially treated to provide strength, flex life and resistance to stretching.

Synchro-Cog belts are ideal for use in positioning applications or on inaccessible drives where maintenance is difficult. Synchro-Cog belts eliminate lubrication and re-tensioning, while providing a long service life.



Synchro-Cog trapezoidal timing belts are available in the following pitches:	XL	=	Extra Light	(0.200" pitch)
	L	=	Light	(0.375" pitch)
	H	=	Heavy	(0.500" pitch)
	XH	=	Extra Heavy	(0.875" pitch)
	XXH	=	Double Extra Heavy	(1.250" pitch)

Synchro-Cog® Timing Belt

Synchronous Drive Belt

Synchro-Cog® Timing Belt Part Numbers

Part Number	Number of Teeth	Pitch Length (in)	Weight (lbs)
XL (1/5") Pitch – Recommended Pulleys: Timing Pulleys – MPB, QD, Taper Bushed (XL)			
50XL025	25	5.0	0.01
50XL037	25	5.0	0.01
60XL025	30	6.0	0.05
60XL037	30	6.0	0.08
70XL025	35	7.0	0.01
70XL037	35	7.0	0.01
80XL025	40	8.0	0.01
80XL037	40	8.0	0.01
90XL025	45	9.0	0.01
90XL037	45	9.0	0.01
100XL025	50	10.0	0.01
100XL037	50	10.0	0.01
110XL025	55	11.0	0.01
110XL037	55	11.0	0.01
120XL025	60	12.0	0.01
120XL037	60	12.0	0.02
130XL025	65	13.0	0.01
130XL037	65	13.0	0.02
140XL025	70	14.0	0.01
140XL037	70	14.0	0.02
150XL025	75	15.0	0.01
150XL037	75	15.0	0.02
160XL025	80	16.0	0.01
160XL037	80	16.0	0.02
170XL025	85	17.0	0.02
170XL037	85	17.0	0.02
180XL025	90	18.0	0.02
180XL037	90	18.0	0.02
190XL025	95	19.0	0.02
190XL037	95	19.0	0.03
200XL025	100	20.0	0.02
200XL037	100	20.0	0.03
210XL025	105	21.0	0.02
210XL037	105	21.0	0.03
220XL025	110	22.0	0.02

Part Number Example: **210XL037** =
210 – **XL** – **037**
Pitch Length (inches in tenths: 21.0") Tooth Pitch (inches) Width (inches in tenths: 0.37")

Part Number	Number of Teeth	Pitch Length (in)	Weight (lbs)
XL (1/5") Pitch – Recommended Pulleys: Timing Pulleys – MPB, QD, Taper Bushed (XL)			
220XL037	110	22.0	0.01
230XL025	115	23.0	0.02
230XL037	115	23.0	0.03
240XL025	120	24.0	0.02
240XL037	120	24.0	0.03
250XL025	125	25.0	0.02
250XL037	125	25.0	0.03
260XL025	130	26.0	0.02
260XL037	130	26.0	0.03
270XL025	135	27.0	0.02
270XL037	135	27.0	0.03
280XL025	140	28.0	0.03
280XL037	140	28.0	0.04
290XL025	145	29.0	0.03
290XL037	145	29.0	0.04
300XL025	150	30.0	0.03
300XL037	150	30.0	0.04
310XL025	155	31.0	0.03
310XL037	155	31.0	0.04
330XL025	165	33.0	0.03
330XL037	165	33.0	0.04
340XL025	170	34.0	0.03
340XL037	170	34.0	0.04
350XL025	175	35.0	0.03
350XL037	175	35.0	0.05
370XL025	185	37.0	0.03
370XL037	185	37.0	0.05
380XL025	190	38.0	0.03
380XL037	190	38.0	0.05
390XL025	195	39.0	0.03
390XL037	195	39.0	0.05
400XL025	200	40.0	0.04
400XL037	200	40.0	0.05
420XL025	210	42.0	0.04
420XL037	210	42.0	0.06

Synchro-Cog® Timing Belt

Synchronous Drive Belt

Synchro-Cog® Timing Belt Part Numbers

Part Number	Number of Teeth	Pitch Length (in)	Weight (lbs)
XL (1/5") Pitch – Recommended Pulleys: Timing Pulleys – MPB, QD, Taper Bushed (XL)			
450XL025	225	45.0	0.04
450XL037	225	45.0	0.06
460XL025	230	46.0	0.04
460XL037	230	46.0	0.06
480XL025	240	48.0	0.10
480XL037	240	48.0	0.06
570XL025	285	57.0	0.05
570XL037	285	57.0	0.08
630XL025	315	63.0	0.06
630XL037	315	63.0	0.08
L (3/8") Pitch – Recommended Pulleys: Timing Pulleys – MPB, QD, Taper Bushed (L)			
124L050	33	12.4	0.03
124L075	33	12.4	0.05
124L100	33	12.4	0.06
135L050	36	13.5	0.03
135L075	36	13.5	0.05
135L100	36	13.5	0.07
150L050	40	15.0	0.04
150L075	40	15.0	0.06
150L100	40	15.0	0.08
165L050	44	16.5	0.04
165L075	44	16.5	0.06
165L100	44	16.5	0.08
187L050	50	18.8	0.05
187L075	50	18.8	0.07
187L100	50	18.8	0.09
195L050	52	19.5	0.05
195L075	52	19.5	0.07
195L100	52	19.5	0.10
210L050	56	21.0	0.05
210L075	56	21.0	0.08
210L100	56	21.0	0.11

Part Number	Number of Teeth	Pitch Length (in)	Weight (lbs)
L (3/8") Pitch – Recommended Pulleys: Timing Pulleys – MPB, QD, Taper Bushed (L)			
225L050	60	22.5	0.06
225L075	60	22.5	0.09
225L100	60	22.5	0.11
240L050	64	24.0	0.06
240L075	64	24.0	0.09
240L100	64	24.0	0.12
255L050	68	25.5	0.06
255L075	68	25.5	0.10
255L100	68	25.5	0.13
270L050	72	27.0	0.07
270L075	72	27.0	0.10
270L100	72	27.0	0.14
285L050	76	28.5	0.07
285L075	76	28.5	0.11
285L100	76	28.5	0.14
300L050	80	30.0	0.08
300L075	80	30.0	0.11
300L100	80	30.0	0.15
315L050	84	31.5	0.08
315L075	84	31.5	0.12
315L100	84	31.5	0.16
322L050	86	32.3	0.08
322L075	86	32.3	0.12
322L100	86	32.3	0.16
345L050	92	34.5	0.09
345L075	92	34.5	0.13
345L100	92	34.5	0.17
367L050	98	36.8	0.09
367L075	98	36.8	0.14
367L100	98	36.8	0.19
390L050	104	39.0	0.10
390L075	104	39.0	0.15
390L100	104	39.0	0.20

Synchro-Cog® Timing Belt

Synchronous Drive Belt

Part Number Example: **300H100** = **300** - **H** - **100**
Pitch Length (inches in tenths: 30.0") Tooth Pitch (inches) Width (inches in tenths: 1.00")

Part Number	Number of Teeth	Pitch Length (in)	Weight (lbs)
L (3/8") Pitch – Recommended Pulleys: Timing Pulleys – MPB, QD, Taper Bushed (L)			
420L050	112	42.0	0.11
420L075	112	42.0	0.16
420L100	112	42.0	0.21
450L050	120	45.0	0.11
450L075	120	45.0	0.17
450L100	120	45.0	0.23
480L050	128	48.0	0.12
480L075	128	48.0	0.18
480L100	128	48.0	0.24
510L050	136	51.0	0.13
510L075	136	51.0	0.19
510L100	136	51.0	0.26
540L050	144	54.0	0.14
540L075	144	54.0	0.20
540L100	144	54.0	0.27
600L050	160	60.0	0.15
600L075	160	60.0	0.23
600L100	160	60.0	0.30
660L050	176	66.0	0.15
660L075	176	66.0	0.25
660L100	176	66.0	0.33
817L050	218	81.8	0.21
817L075	218	81.8	0.31
817L100	218	81.8	0.41
900L050	240	90.0	0.23
900L075	240	90.0	0.34
900L100	240	90.0	0.46
H (1/2") Pitch – Recommended Pulleys: Timing Pulleys – MPB, QD, Taper Bushed (H)			
210H075	42	21.0	0.10
210H100	42	21.0	0.14
210H150	42	21.0	0.21
210H200	42	21.0	0.28

Part Number	Number of Teeth	Pitch Length (in)	Weight (lbs)
H (1/2") Pitch – Recommended Pulleys: Timing Pulleys – MPB, QD, Taper Bushed (H)			
210H300	42	21.0	0.42
220H075	44	22.0	0.11
220H100	44	22.0	0.15
220H150	44	22.0	0.22
220H200	44	22.0	0.29
220H300	44	22.0	0.44
230H075	46	23.0	0.11
230H100	46	23.0	0.15
230H150	46	23.0	0.23
230H200	46	23.0	0.31
230H300	46	23.0	0.46
240H075	48	24.0	0.12
240H100	48	24.0	0.16
240H150	48	24.0	0.24
240H200	48	24.0	0.32
240H300	48	24.0	0.48
270H075	54	27.0	0.13
270H100	54	27.0	0.18
270H150	54	27.0	0.27
270H200	54	27.0	0.36
270H300	54	27.0	0.54
300H075	60	30.0	0.15
300H100	60	30.0	0.20
300H150	60	30.0	0.30
300H200	60	30.0	0.40
300H300	60	30.0	0.60
320H075	64	32.0	0.16
320H100	64	32.0	0.21
320H150	64	32.0	0.32
320H200	64	32.0	0.42
320H300	64	32.0	0.64
330H075	66	33.0	0.16
330H100	66	33.0	0.22

Synchro-Cog® Timing Belt

Synchronous Drive Belt

Synchro-Cog® Timing Belt Part Numbers

Part Number	Number of Teeth	Pitch Length (in)	Weight (lbs)
H (1/2") Pitch – Recommended Pulleys: Timing Pulleys – MPB, QD, Taper Bushed (H)			
330H150	66	33.0	0.33
330H200	66	33.0	0.44
330H300	66	33.0	0.66
340H075	68	34.0	0.17
340H100	68	34.0	0.23
340H150	68	34.0	0.34
340H200	68	34.0	0.45
340H300	68	34.0	0.68
350H075	70	35.0	0.17
350H100	70	35.0	0.23
350H150	70	35.0	0.35
350H200	70	35.0	0.46
350H300	70	35.0	0.70
360H075	72	36.0	0.18
360H100	72	36.0	0.24
360H150	72	36.0	0.36
360H200	72	36.0	0.48
360H300	72	36.0	0.72
370H075	74	37.0	0.18
370H100	74	37.0	0.25
370H150	74	37.0	0.37
370H200	74	37.0	0.49
370H300	74	37.0	0.74
390H075	78	39.0	0.19
390H100	78	39.0	0.26
390H150	78	39.0	0.39
390H200	78	39.0	0.52
390H300	78	39.0	0.78
400H075	80	40.0	0.20
400H100	80	40.0	0.27
400H150	80	40.0	0.40
400H200	80	40.0	0.53
400H300	80	40.0	0.80

Part Number	Number of Teeth	Pitch Length (in)	Weight (lbs)
H (1/2") Pitch – Recommended Pulleys: Timing Pulleys – MPB, QD, Taper Bushed (H)			
410H075	82	41.0	0.20
410H100	82	41.0	0.27
410H150	82	41.0	0.41
410H200	82	41.0	0.54
410H300	82	41.0	0.82
420H075	84	42.0	0.21
420H100	84	42.0	0.28
420H150	84	42.0	0.42
420H200	84	42.0	0.56
420H300	84	42.0	0.84
450H075	90	45.0	0.22
450H100	90	45.0	0.30
450H150	90	45.0	0.45
450H200	90	45.0	0.60
450H300	90	45.0	0.90
480H075	96	48.0	0.24
480H100	96	48.0	0.32
480H150	96	48.0	0.48
480H200	96	48.0	0.64
480H300	96	48.0	0.96
490H075	98	49.0	0.24
490H100	98	49.0	0.33
490H150	98	49.0	0.49
490H200	98	49.0	0.65
490H300	98	49.0	0.98
510H075	102	51.0	0.25
510H100	102	51.0	0.34
510H150	102	51.0	0.51
510H200	102	51.0	0.68
510H300	102	51.0	1.02
540H075	108	54.0	0.27
540H100	108	54.0	0.36
540H150	108	54.0	0.54

Synchro-Cog® Timing Belt

Synchronous Drive Belt

Part Number Example: **645H300** = **645** – **H** – **300**
Pitch Length (inches in tenths: 64.5") Tooth Pitch (inches) Width (inches in tenths: 3.00")

Part Number	Number of Teeth	Pitch Length (in)	Weight (lbs)
H (1/2") Pitch – Recommended Pulleys: Timing Pulleys – MPB, QD, Taper Bushed (H)			
540H200	108	54.0	0.72
540H300	108	54.0	1.08
560H075	112	56.0	0.28
560H100	112	56.0	0.37
560H150	112	56.0	0.56
560H200	112	56.0	0.74
560H300	112	56.0	1.12
570H075	114	57.0	0.28
570H100	114	57.0	0.38
570H150	114	57.0	0.57
570H200	114	57.0	0.76
570H300	114	57.0	1.14
585H075	117	58.5	0.29
585H100	117	58.5	0.39
585H150	117	58.5	0.58
585H200	117	58.5	0.78
585H300	117	58.5	1.16
600H075	120	60.0	0.30
600H100	120	60.0	0.40
600H150	120	60.0	0.60
600H200	120	60.0	0.80
600H300	120	60.0	1.19
630H075	126	63.0	0.31
630H100	126	63.0	0.42
630H150	126	63.0	0.63
630H200	126	63.0	0.84
630H300	126	63.0	1.25
645H075	129	64.5	0.32
645H100	129	64.5	0.43
645H150	129	64.5	0.64
645H200	129	64.5	0.86
645H300	129	64.5	1.28
660H075	132	66.0	0.33

Part Number	Number of Teeth	Pitch Length (in)	Weight (lbs)
H (1/2") Pitch – Recommended Pulleys: Timing Pulleys – MPB, QD, Taper Bushed (H)			
660H100	132	66.0	0.44
660H150	132	66.0	0.66
660H200	132	66.0	0.88
660H300	132	66.0	1.31
700H075	140	70.0	0.35
700H100	140	70.0	0.46
700H150	140	70.0	0.70
700H200	140	70.0	0.93
700H300	140	70.0	1.39
730H075	146	73.0	0.36
730H100	146	73.0	0.48
730H150	146	73.0	0.73
730H200	146	73.0	0.97
730H300	146	73.0	1.45
750H075	150	75.0	0.37
750H100	150	75.0	0.50
750H150	150	75.0	0.75
750H200	150	75.0	1.00
750H300	150	75.0	1.49
780H075	156	78.0	0.39
780H100	156	78.0	0.52
780H150	156	78.0	0.78
780H200	156	78.0	1.04
780H300	156	78.0	1.55
800H075	160	80.0	0.40
800H100	160	80.0	0.53
800H150	160	80.0	0.80
800H200	160	80.0	1.06
800H300	160	80.0	1.59
820H075	164	82.0	0.41
820H100	164	82.0	0.54
820H150	164	82.0	0.82
820H200	164	82.0	1.09

Synchro-Cog® Timing Belt

Synchronous Drive Belt

Synchro-Cog® Timing Belt Part Numbers

Part Number	Number of Teeth	Pitch Length (in)	Weight (lbs)
H (1/2") Pitch – Recommended Pulleys: Timing Pulleys – MPB, QD, Taper Bushed (H)			
820H300	164	82.0	1.63
840H075	168	84.0	0.42
840H100	168	84.0	0.56
840H150	168	84.0	0.84
840H200	168	84.0	1.12
840H300	168	84.0	1.67
850H075	170	85.0	0.42
850H100	170	85.0	0.56
850H150	170	85.0	0.85
850H200	170	85.0	1.13
850H300	170	85.0	1.69
900H075	180	90.0	0.45
900H100	180	90.0	0.60
900H150	180	90.0	0.90
900H200	180	90.0	1.19
900H300	180	90.0	1.79
960H075	192	96.0	0.48
960H100	192	96.0	0.64
960H150	192	96.0	0.96
960H200	192	96.0	1.27
960H300	192	96.0	1.91
1000H075	200	100.0	0.50
1000H100	200	100.0	0.66
1000H150	200	100.0	1.00
1000H200	200	100.0	1.33
1000H300	200	100.0	1.99
1100H075	220	110.0	0.55
1100H100	220	110.0	0.73
1100H150	220	110.0	1.10
1100H200	220	110.0	1.46
1100H300	220	110.0	2.19
1140H075	228	114.0	0.57
1140H100	228	114.0	0.76

Part Number	Number of Teeth	Pitch Length (in)	Weight (lbs)
H (1/2") Pitch – Recommended Pulleys: Timing Pulleys – MPB, QD, Taper Bushed (H)			
1140H150	228	114.0	1.14
1140H200	228	114.0	1.51
1140H300	228	114.0	2.27
1150H075	230	115.0	0.60
1150H100	230	115.0	0.60
1150H150	230	115.0	1.60
1150H200	230	115.0	2.00
1150H300	230	115.0	2.50
1250H075	250	125.0	0.62
1250H100	250	125.0	0.83
1250H150	250	125.0	1.24
1250H200	250	125.0	1.66
1250H300	250	125.0	2.49
1400H075	280	140.0	0.70
1400H100	280	140.0	0.93
1400H150	280	140.0	1.39
1400H200	280	140.0	1.86
1400H300	280	140.0	2.79
1550H075	310	155.0	0.77
1550H100	310	155.0	1.03
1550H150	310	155.0	1.54
1550H200	310	155.0	2.06
1550H300	310	155.0	3.09
1700H075	340	170.0	0.85
1700H100	340	170.0	1.13
1700H150	340	170.0	1.69
1700H200	340	170.0	2.26
1700H300	340	170.0	3.39
XH (7/8") Pitch – Recommended Pulleys: Timing Pulleys – MPB, QD, Taper Bushed (XH)			
507XH200	58	50.8	1.65
507XH300	58	50.8	2.47
507XH400	58	50.8	3.30

Synchro-Cog® Timing Belt

Synchronous Drive Belt

Part Number Example: **630XH200** = **630** – **H** – **200**
Pitch Length (inches in tenths: 63.0") Tooth Pitch (inches) Width (inches in tenths: 2.00")

Part Number	Number of Teeth	Pitch Length (in)	Weight (lbs)
XH (7/8") Pitch – Recommended Pulleys: Timing Pulleys – MPB, QD, Taper Bushed (XH)			
560XH200	64	56.0	1.82
560XH300	64	56.0	2.73
560XH400	64	56.0	3.64
630XH200	72	63.0	2.05
630XH300	72	63.0	3.08
630XH400	72	63.0	4.10
700XH200	80	70.0	2.28
700XH300	80	70.0	3.42
700XH400	80	70.0	4.56
770XH200	88	77.0	2.51
770XH300	88	77.0	3.76
770XH400	88	77.0	5.01
840XH200	96	84.0	2.73
840XH300	96	84.0	4.10
840XH400	96	84.0	5.47
980XH200	112	98.0	3.19
980XH300	112	98.0	4.78
980XH400	112	98.0	6.38
1120XH200	128	112.0	3.64
1120XH300	128	112.0	5.47
1120XH400	128	112.0	7.29
1260XH200	144	126.0	4.10
1260XH300	144	126.0	6.15
1260XH400	144	126.0	8.20
1400XH200	160	140.0	4.56
1400XH300	160	140.0	6.83
1400XH400	160	140.0	9.11
1540XH200	176	154.0	5.01
1540XH300	176	154.0	7.52
1540XH400	176	154.0	10.02
1750XH200	200	175.0	5.69
1750XH300	200	175.0	8.54
1750XH400	200	175.0	11.39

Part Number	Number of Teeth	Pitch Length (in)	Weight (lbs)
XXH (1-1/4") Pitch - Recommended Pulleys: Timing Pulleys – MPB, QD, Taper Bushed (XXH)			
700XXH200	56	70.0	3.00
700XXH300	56	70.0	4.49
700XXH400	56	70.0	5.99
700XXH500	56	70.0	7.49
800XXH200	64	80.0	3.42
800XXH300	64	80.0	5.13
800XXH400	64	80.0	6.85
800XXH500	64	80.0	8.56
900XXH200	72	90.0	3.85
900XXH300	72	90.0	5.78
900XXH400	72	90.0	7.70
900XXH500	72	90.0	9.63
1000XXH200	80	100.0	4.28
1000XXH300	80	100.0	6.42
1000XXH400	80	100.0	8.56
1000XXH500	80	100.0	10.70
1200XXH200	96	120.0	5.13
1200XXH300	96	120.0	7.70
1200XXH400	96	120.0	10.27
1200XXH500	96	120.0	12.84
1400XXH200	112	140.0	5.99
1400XXH300	112	140.0	8.99
1400XXH400	112	140.0	11.98
1400XXH500	112	140.0	14.98
1600XXH200	128	160.0	6.85
1600XXH300	128	160.0	10.27
1600XXH400	128	160.0	13.69
1600XXH500	128	160.0	17.11
1800XXH200	144	180.0	7.70
1800XXH300	144	180.0	11.55
1800XXH400	144	180.0	15.40
1800XXH500	144	180.0	19.25

Synchro-Cog® Timing Belt Sleeves

- Full factory width sleeves
- Sleeve edges are trimmed before shipment
- Sleeves cannot be accepted for return

Timken Belts maintains inventory of most sleeve sizes. Contact customer service for availability. Minimum order quantity and/or extended lead times may apply.

Occasional production inconsistencies which may render a portion of the sleeve unusable can be present as a normal part of the production process.

Each sleeve is inspected to ensure that it contains 90% or more usable product. A full width sleeve with less than 10% unusable product is considered acceptable.



Synchro-Cog® Timing Belt Sleeve Part Numbers

Part Number	Sleeve Width (in)	Weight (lbs)
XL (1/5") Pitch – Recommended Pulleys: Timing Pulleys – MPB, QD, Taper Bushed (XL)		
60XL1600SL	16.0	0.34
70XL1600SL	16.0	0.40
80XL1600SL	16.0	0.46
90XL1600SL	16.0	0.90
100XL2800SL	28.0	1.00
110XL2800SL	28.0	1.10
120XL2800SL	28.0	1.20
130XL2800SL	28.0	1.30
140XL2800SL	28.0	1.40
150XL2800SL	28.0	1.50
160XL2800SL	28.0	1.60
170XL2800SL	28.0	1.70
180XL1600SL	16.0	1.03
190XL1600SL	16.0	1.09
200XL1600SL	16.0	1.14
210XL1600SL	16.0	1.20
220XL1600SL	16.0	1.26
230XL1600SL	16.0	1.31
240XL1600SL	16.0	1.37
250XL1600SL	16.0	1.43
260XL1600SL	16.0	1.49
270XL1800SL	18.0	1.6
290XL2126SL	21.3	2.20
310XL1850SL	18.5	2.05
330XL1850SL	18.5	2.18
380XL1850SL	18.5	2.20
390XL1850SL	18.5	2.58
L (3/8") Pitch – Recommended Pulleys: Timing Pulleys – MPB, QD, Taper Bushed (L)		
124L1600SL	16.0	1.00
135L1500SL	15.0	1.00
150L2800SL	28.0	2.12
165L1800SL	18.0	2.10
187L2800SL	28.0	2.65
210L1600SL	16.0	1.70

Synchro-Cog® Timing Belt Sleeves

Part Number Example: **200XL1600SL** = **200** **XL** **1600** **SL**
Pitch Length (inches in tenths: 20.0") Tooth Pitch (inches) Width (inches in hundredths: 16.00") Sleeve

Part Number	Sleeve Width (in)	Weight (lbs)
L (3/8") Pitch – Recommended Pulleys: Timing Pulleys – MPB, OD, Taper Bushed (L)		
225L3800SL	38.0	4.32
240L3800SL	38.0	4.61
255L3800SL	38.0	4.90
270L3800SL	38.0	5.19
285L3800SL	38.0	5.48
300L3800SL	38.0	5.77
322L3800SL	38.0	6.19
345L3800SL	38.0	6.63
367L3800SL	38.0	7.05
390L3800SL	38.0	7.50
420L3800SL	38.0	8.07
450L1850SL	18.5	4.21
480L1850SL	18.5	4.49
510L1850SL	18.5	4.77
540L1850SL	18.5	5.05
600L3800SL	38.0	11.53
817L1850SL	18.5	7.65
H (1/2") Pitch – Recommended Pulleys: Timing Pulleys – MPB, OD, Taper Bushed (H)		
240H3800SL	38.0	6.05
270H3800SL	38.0	6.81
300H3800SL	38.0	7.57
330H3800SL	38.0	8.32
360H3800SL	38.0	9.08
390H3800SL	38.0	9.84
420H3800SL	38.0	10.59
450H3800SL	38.0	11.35
480H3800SL	38.0	12.11
510H3800SL	38.0	12.86
540H3800SL	38.0	13.62
570H3800SL	38.0	14.38
600H3800SL	38.0	15.13
630H3800SL	38.0	15.89
660H3800SL	38.0	16.65
700H3800SL	38.0	17.66

Part Number	Sleeve Width (in)	Weight (lbs)
H (1/2") Pitch – Recommended Pulleys: Timing Pulleys – MPB, OD, Taper Bushed (H)		
750H3800SL	38.0	18.92
800H2200SL	22.0	11.68
850H2200SL	22.0	12.41
900H2200SL	22.0	1.19
1000H2200SL	22.0	14.60
1100H2200SL	22.0	15.52
1140H2126SL	21.3	13.62
1150H1800SL	18.0	13.8
1250H2200SL	22.0	18.25
1400H2200SL	22.0	20.44
1700H2200SL	22.0	23.99
XH (7/8") Pitch – Recommended Pulleys: Timing Pulleys – MPB, OD, Taper Bushed (XH)		
507XH2126SL	21.3	31.35
560XH3800SL	38.0	34.62
630XH3800SL	38.0	38.95
700XH3800SL	38.0	43.28
770XH3800SL	38.0	47.61
840XH2126SL	21.3	29.06
980XH2200SL	22.0	35.08
1120XH2126SL	21.3	38.74
1260XH2126SL	21.3	43.59
1400XH2126SL	21.3	48.43
1540XH2126SL	21.3	53.27
1750XH2126SL	21.3	60.54
XXH (1-1/4") Pitch - Recommended Pulleys: Timing Pulleys – MPB, OD, Taper Bushed (XXH)		
800XXH2126SL	21.3	36.39
900XXH2126SL	21.3	40.93
1000XXH2126SL	21.3	45.48
1200XXH2126SL	21.3	54.58
1400XXH2126SL	21.3	63.68
1600XXH2126SL	21.3	72.77
1800XXH2126SL	21.3	81.87

Dual Synchro-Cog® Timing Belt

Synchronous Drive Belt



Dual Synchro-Cog® Timing Belt

Synchronous Drive Belt



Recommended Sprockets:
Timing Pulleys – MPB, QD, Taper Bushed (XL, L, H)

Double-sided
trapezoidal tooth profile

100% load capacity from
both sides of the belt

Greater flexibility in
drive design

Optimum drive
efficiency

Maintenance-free,
clean and quiet

Applications:

Machine tools
Packaging equipment
Industrial Machinery
& More

Dual Synchro-Cog® Timing Belt

Synchronous Drive Belt

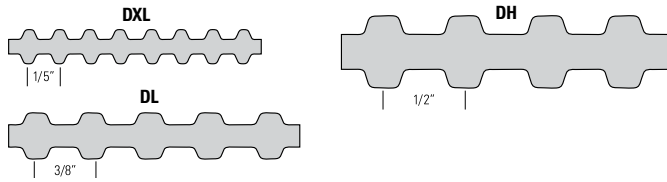

Double-sided timing belt with a trapezoidal tooth profile provides synchronization and 100% load capacity from both sides of the belt

Trapezoidal tooth profile provides maintenance-free synchronization with equal load capacity from both sides of the belt. This feature is not found in every dual-sided belt on the market.

The Synchro-Cog Dual Timing Belt allows greater flexibility and efficiency in drive design. The freedom to use a single belt for a series of pulleys results in a more efficient use of available space with decreased overall drive weight and cost. The non-slip positive drive provides smooth, clean, quiet performance with optimum efficiency.

The belt features an advanced polymer construction with molded teeth that are sheer resistant and designed to assure smooth, positive meshing with the sprocket. A tough nylon tooth facing is wear resistant. High quality fiberglass cords are specially treated to provide strength, flex life and resistance to stretching. The belt resists oil, heat, ozone, grease, and moisture for maximum belt life.

Part Number Example: **D-770-XL-025** =

D	-	770	-	XL	-	025
Dual Sided		Pitch Length (in Tenths of an Inch)		Tooth Pitch		1/4-Inch Belt Width

Dual Synchro-Cog® Timing Belt Part Numbers

Part Number	Number of Teeth	Pitch Length (in)	Weight (lbs)
Dual Sided XL (1/5" pitch)			
Recommended Pulleys: – MPB, QD, Taper Bushed (XL)			
D130XL037	65	13.0	0.02
D170XL037	85	17.0	0.02
D180XL025	90	18.0	0.03
D210XL037	105	21.0	0.03
D260XL037	130	26.0	0.04
D280XL037	140	28.0	1.65
D380XL037	190	38.0	0.19
Dual Sided L (3/8" pitch)			
Recommended Pulleys: – MPB, QD, Taper Bushed (L)			
D150L050	40	15.0	0.04
D187L050	50	18.8	0.56
D210L050	56	21.0	0.05
D225L050	60	22.5	0.05
D240L050	64	24.0	0.06
D240L100	64	24.0	0.11
D270L050	72	27.0	0.06
D270L100	72	27.0	0.11
D322L050	86	32.2	0.69
D322L100	86	32.2	0.23
D345L100	92	34.5	0.16
D390L050	104	39.0	0.15
D390L075	104	39.0	0.26
D420L050	112	42.0	0.10
D420L100	112	42.0	0.19
D450L050	120	45.0	0.10
D450L100	120	45.0	0.21
D480L050	128	48.0	0.11
D480L100	128	48.0	0.22
D510L050	136	51.0	0.12
D510L075	136	51.0	0.02

Dual Synchro-Cog® Timing Belt

Synchronous Drive Belt

Part Number	Number of Teeth	Pitch Length (in)	Weight (lbs)
Dual Sided L (3/8" pitch)			
Recommended Pulleys: – MPB, QD, Taper Bushed (L)			
D510L100	136	51.0	0.24
D540L050	144	54.0	0.13
D540L100	144	54.0	0.25
D600L050	160	60.0	0.14
D600L075	160	60.0	0.21
D600L100	160	60.0	0.28
Dual Sided H (1/2" pitch)			
Recommended Pulleys: – MPB, QD, Taper Bushed (H)			
D240H150	48	24.0	0.80
D270H100	54	27.0	0.20
D270H200	54	27.0	0.39
D390H100	78	39.0	0.28
D420H100	84	42.0	0.30
D450H075	90	45.0	0.24
D450H100	90	45.0	0.33
D450H300	90	45.0	2.54
D480H075	96	48.0	0.03
D480H100	96	48.0	0.35
D480H150	96	48.0	0.52
D480H200	96	48.0	3.05
D480H300	96	48.0	0.33
D510H100	102	51.0	0.37
D510H150	102	51.0	0.55
D510H300	102	51.0	2.72
D540H100	108	54.0	0.39
D540H150	108	54.0	0.58
D540H300	108	54.0	2.46
D570H075	114	57.0	0.03
D570H100	114	57.0	0.41
D570H150	114	57.0	0.62
D600H100	120	60.0	0.43
D600H150	120	60.0	0.65
D600H200	120	60.0	0.87
D600H300	120	60.0	1.30

Part Number	Number of Teeth	Pitch Length (in)	Weight (lbs)
Dual Sided H (1/2" pitch)			
Recommended Pulleys: – MPB, QD, Taper Bushed (H)			
D630H100	126	63.0	0.45
D630H150	126	63.0	0.68
D660H075	132	66.0	0.69
D660H100	132	66.0	0.48
D660H200	132	66.0	0.95
D660H300	132	66.0	1.43
D700H100	140	70.0	0.51
D700H150	140	70.0	0.70
D700H200	140	70.0	0.85
D700H300	140	70.0	0.62
D750H100	150	75.0	0.54
D750H150	150	75.0	0.77
D750H200	150	75.0	1.08
D750H300	150	75.0	1.12
D800H075	160	80.0	0.04
D800H100	160	80.0	0.78
D800H150	160	80.0	0.80
D800H200	160	80.0	1.15
D800H300	160	80.0	0.45
D850H075	170	85.0	0.67
D850H100	170	85.0	0.61
D850H200	170	85.0	1.23
D850H300	170	85.0	1.13
D900H100	180	90.0	0.65
D900H150	180	90.0	0.82
D900H200	180	90.0	0.13
D900H300	180	90.0	0.70
D1000H100	200	100.0	0.66
D1000H200	200	100.0	1.44
D1000H300	200	100.0	0.81
D1100H100	220	110.0	0.79
D1100H150	220	110.0	0.98
D1100H200	220	110.0	1.59
D1100H300	220	110.0	0.47

Dual Synchro-Cog® Timing Belt

Synchronous Drive Belt

Dual Synchro-Cog® Timing Belt Part Numbers

Part Number	Number of Teeth	Pitch Length (in)	Weight (lbs)
Dual Sided H (1/2" pitch) Recommended Pulleys: – MPB, OD, Taper Bushed (H)			
D1250H100	250	125.0	0.90
D1250H200	250	125.0	0.18
D1250H300	250	125.0	2.71
D1400H100	280	140.0	1.01
D1400H150	280	140.0	1.51
D1400H200	280	140.0	2.02
D1400H300	280	140.0	3.03
D1700H100	340	170.0	1.23
D1700H200	340	170.0	2.45



Dual Synchro-Cog® Timing Belts

Sleeves

- Full factory width sleeves
- Sleeve edges are trimmed before shipment
- Sleeves cannot be accepted for return

Timken Belts maintains inventory of most sleeve sizes. Contact customer service for availability. Minimum order quantity and/or extended lead times may apply.

Occasional production inconsistencies which may render a portion of the sleeve unusable can be present as a normal part of the production process.

Each sleeve is inspected to ensure that it contains 90% or more usable product. A full width sleeve with less than 10% unusable product is considered acceptable.

Dual Synchro-Cog® Timing Belt Sleeve Part Numbers

Part Number	Sleeve Width (in)	Weight (lbs)
Dual Sided XL (1/5" pitch)		
Recommended Pulleys: – MPB, QD, Taper Bushed (XL)		
D200XL180SL	180	0.6
D210XL180SL	180	0.5
D220XL180SL	180	0.7
D230XL180SL	180	0.6
D234XL180SL	180	0.7
D234XL200SL	200	0.6
D240XL180SL	180	0.6
D250XL180SL	180	0.6
D260XL180SL	180	0.6
D260XL600SL	600	0.4
D270XL180SL	180	0.7
D280XL180SL	180	0.7
D290XL180SL	180	0.9
D300XL180SL	180	0.7
D310XL180SL	180	1.0
D320XL180SL	180	0.8
D330XL180SL	180	1.0
D340XL180SL	180	0.8
D352XL180SL	180	0.9
D356XL180SL	180	0.2
D360XL180SL	180	1.1
D380XL180SL	180	0.9
D384XL180SL	180	1.2
D492XL180SL	180	1.5
D514XL180SL	180	1.6
D580XL180SL	180	1.8
Dual Sided L (3/8" pitch)		
Recommended Pulleys: – MPB, QD, Taper Bushed (L)		
D180L200SL	200	0.7
D187L180SL	180	0.8
D187L200SL	200	0.7
D195L200SL	200	0.7
D210L200SL	200	0.8
D217L200SL	200	0.8

Dual Synchro-Cog® Timing Belts

Sleeves

Dual Synchro-Cog® Timing Belt Sleeve Part Numbers

Part Number	Sleeve Width (in)	Weight (lbs)
Dual Sided L (3/8" pitch) Recommended Pulleys: – MPB, QD, Taper Bushed (L)		
D225L180SL	180	1.0
D240L180SL	180	1.1
D240L200SL	200	0.9
D244L200SL	200	0.9
D255L180SL	180	1.1
D255L200SL	200	0.9
D277L200SL	200	1.2
D281L200SL	200	1.2
D285L180SL	180	1.3
D285L200SL	200	1.0
D300L200SL	200	1.1
D315L180SL	180	1.0
D315L200SL	200	0.5
D322L200SL	200	4.6
D334L200SL	200	0.3
D337L200SL	200	0.3
D345L180SL	180	1.5
D345L200SL	200	1.3
D352L200SL	200	12.8
D367L200SL	200	1.6
D375L180SL	180	1.2
D375L200SL	200	1.4
D390L180SL	180	1.3
D390L200SL	200	1.9
D405L180SL	180	1.3
D420L200SL	200	3.9
D427L200SL	200	1.6
D435L180SL	180	1.4
D435L200SL	200	0.4
D450L200SL	200	1.6
D453L200SL	200	16.4
D465L200SL	200	1.7
D480L200SL	200	1.7
D500L200SL	200	0.5

Part Number	Sleeve Width (in)	Weight (lbs)
Dual Sided L (3/8" pitch) Recommended Pulleys: – MPB, QD, Taper Bushed (L)		
D510L200SL	200	1.9
D525L200SL	200	4.8
D540L200SL	200	0.5
D581L200SL	200	2.1
D585L200SL	200	0.5
D600L200SL	200	2.2
D619L180SL	180	0.6
D619L200SL	200	2.2
D630L200SL	200	2.3
D660L200SL	200	2.4
D697L200SL	200	0.6
D915L200SL	200	0.8
Dual Sided H (1/2" pitch) Recommended Pulleys: – MPB, QD, Taper Bushed (H)		
D205H200SL	200	1.3
D225H200SL	200	1.3
D240H200SL	200	1.5
D240H600SL	600	1.2
D245H200SL	200	3.5
D270H200SL	200	1.7
D280H200SL	200	1.6
D300H200SL	200	1.9
D310H200SL	200	1.8
D315H200SL	200	2.0
D320H200SL	200	2.0
D340H200SL	200	1.9
D350H200SL	200	2.0
D360H200SL	200	2.3
D370H200SL	200	0.5
D380H200SL	200	2.4
D390H200SL	200	2.5
D400H200SL	200	2.5
D410H200SL	200	2.6
D420H200SL	200	2.7

Dual Synchro-Cog® Timing Belts

Sleeves

Part Number	Sleeve Width (in)	Weight (lbs)
Dual Sided H (1/2" pitch) Recommended Pulleys: – MPB, OD, Taper Bushed (H)		
D425H200SL	200	2.7
D445H200SL	200	2.8
D450H200SL	200	2.9
D460H200SL	200	2.9
D465H200SL	200	2.6
D470H200SL	200	0.7
D480H200SL	200	2.7
D490H200SL	200	3.1
D500H200SL	200	3.2
D530H200SL	200	3.0
D540H200SL	200	3.1
D550H200SL	200	3.1
D560H200SL	200	3.2
D570H200SL	200	3.6
D580H200SL	200	3.3
D590H200SL	200	3.4
D600H200SL	200	3.8
D605H200SL	200	3.4
D625H200SL	200	4.0
D630H200SL	200	4.0
D630H600SL	600	0.6
D640H200SL	200	3.6
D650H200SL	200	4.1
D660H200SL	200	3.7
D670H200SL	200	3.8
D680H200SL	200	3.9
D690H200SL	200	4.4
D700H200SL	200	4.5
D720H200SL	200	4.6
D725H200SL	200	4.1
D730H200SL	200	4.1
D740H200SL	200	1.1
D750H200SL	200	4.8
D770H200SL	200	4.9

Part Number	Sleeve Width (in)	Weight (lbs)
Dual Sided H (1/2" pitch) Recommended Pulleys: – MPB, OD, Taper Bushed (H)		
D780H200SL	200	4.4
D800H200SL	200	4.5
D820H200SL	200	4.7
D840H200SL	200	7.7
D850H200SL	200	4.8
D860H200SL	200	4.9
D880H200SL	200	1.3
D900H200SL	200	5.7
D920H200SL	200	1.3
D950H200SL	200	6.0
D1000H200SL	200	6.4
D1020H200SL	200	9.2
D1030H200SL	200	5.9
D1050H200SL	200	6.0
D1100H200SL	200	6.2
D1140H200SL	200	6.5
D1150H200SL	200	7.3
D1250H200SL	200	7.1
D1270H200SL	200	7.2
D1350H200SL	200	7.7
D1400H200SL	200	8.0
D1500H200SL	200	9.5
D1560H200SL	200	8.9
D1600H200SL	200	10.2
D1700H200SL	200	9.7

V-Belts

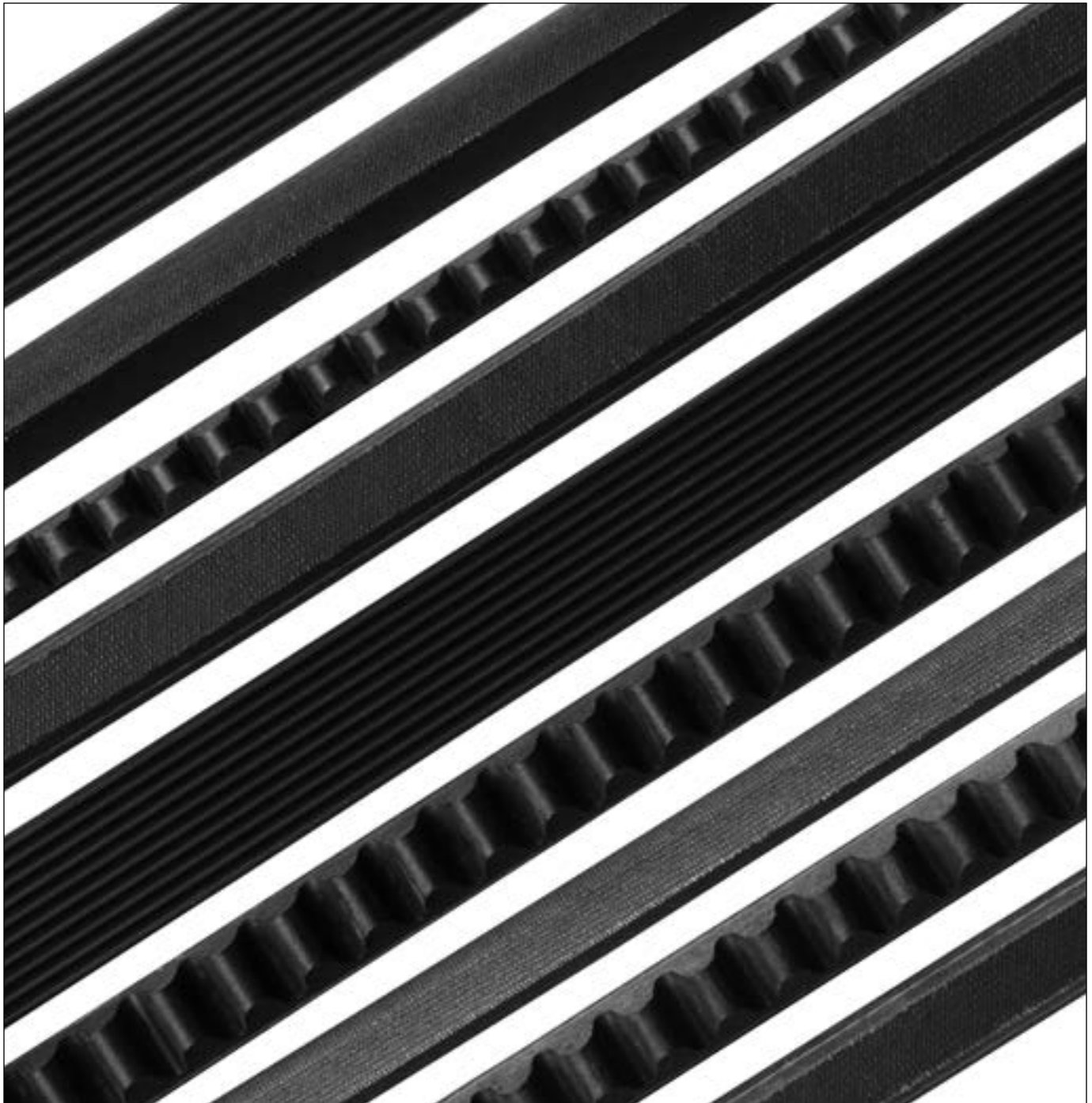

V-Belts

Construction & Drive Advantages

The function of a v-belt is to transmit power from one shaft to another through a driver to a driven pulley (sheaves). The belts must transfer this power efficiently and reliably. V-belts work on the principle of the wedge and rely on proper tension to create friction or grip on the sidewall of the sheave to transmit power. V-belt drive systems are easy to install, require no lubrication, and dampen shock load.

You can depend on Timken belts for a wide range of applications. We've got you covered with the right belt for most any job. Timken belts are purpose-built and designed for optimal performance on the most demanding applications.

V-Belt Construction

There are two major types of v-belt construction, wrapped and raw edge. Wrapped Molded belts are molded into a "V" shape and have a fabric cover. Raw Edge Cog-Belts are cured and then cut into a "V" shape.

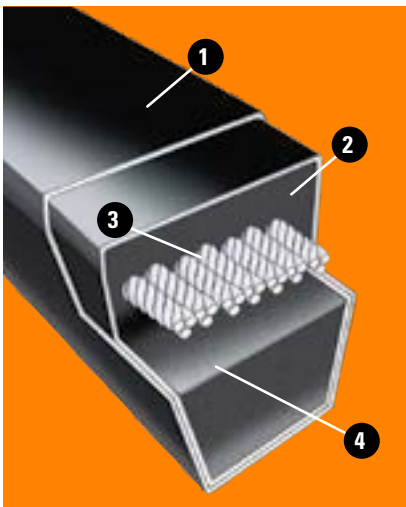

Wrapped Belt

- 1. Cover** – Heavy-duty fabric impregnated with engineered rubber compounds protects the core
- 2. Tension Section** – Synthetic rubber specially formulated to stretch as belt bends around sheaves
- 3. Cord** – High-modulus cord carries the horsepower load with minimum stretch
- 4. Compression Section** – Synthetic rubber compound designed to support cords evenly and compress while bending around the sheaves

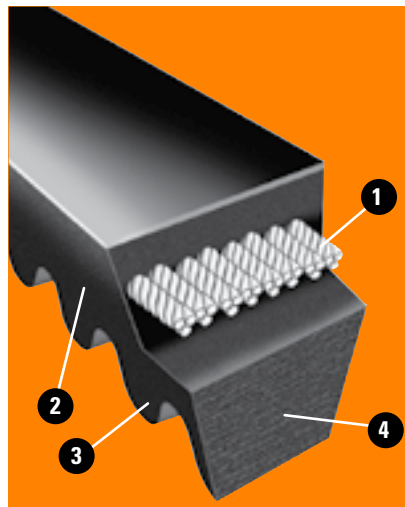

Raw Edge Cog-Belt

- 1. Cord** – High-modulus cord carries the horsepower load with minimum stretch
- 2. Raw Edge Sidewalls** – Provide uniform, anti-slip surface, increase efficiency and reduce vibration
- 3. Cogs** – Precision molded cogs improve belt flex and reduce bending stress
- 4. EPDM** – Offers superior flex and load carrying capacity, resistant to heat and cracking

V-Belt Drive Advantages

V-belt drives provide many advantages that help to reduce equipment repairs and to hold downtime to a minimum.

- V-belts are rugged – they will give years of trouble-free performance when given minimal attention, even under adverse conditions
- V-belts are clean – they require no lubrication
- V-belts are efficient – performing with an average of 93% efficiency; Raw Edge cog-belts are 95% efficient
- V-belts start, stop and run smoothly
- V-belts cover extremely wide horsepower ranges
- V-belts permit a wide range of driven speeds, using standard electric motors
- V-belts dampen vibration between driving and driven machines
- V-belts are quiet
- V-belts act as a mechanical fuse for the system
- V-belts and sheaves wear gradually – so preventive and corrective maintenance is easy
- V-belts are less expensive than other forms of power transmission
- V-belts are relatively unaffected by moisture, dust and variations in temperature

V-Belts

V-Belt Installation Check List & Selection Guide

V-Belt Installation Check List

- 1. Disconnect and lock out power source
- 2. Observe all safety procedures
- 3. Follow the recommendations of the original equipment manufacturer
- 4. Remove belt guard
- 5. Loosen motor mounts
- 6. Shorten center distance
- 7. Remove old belts
- 8. Inspect belt wear patterns for possible troubleshooting
- 9. Inspect drive elements – bearings, shaft, etc
- 10. Inspect sheaves for wear and clean
- 11. Check sheave alignment (preliminary)
- 12. Select proper replacement belts
- 13. Install new belts
- 14. Properly tension belts
- 15. Re-check sheave alignment and tension
- 16. Replace guard
- 17. Start drive (look and listen)
- 18. Check tension after 24 hours

Timken Belts	Chek Mate® Matching	Generic Belt Type (Cross Sections)	Normal Horsepower Range
Gold-Ribbon® Cog-Belt®		Classical Cogged Multiple (AX, BX, CX, DX)	1-500
Super II® V-Belt		Classical Multiple (A, B, C)	1-500
Super Blue Ribbon® V-Belt		Classical Multiple (A, B, C, D)	1-500
Aramax® Xtra Duty V-Belt		Classical Multiple (3L, AK, BK)	1-500
Power-Wedge® Cog-Belt®		Narrow Cogged Multiple (3VX, 5VX, 8VX)	1-600
Metric Power-Wedge® Cog-Belt®		Narrow Cogged Multiple (XPZ, XPA, XPB, XPC)	1-600
Super Power-Wedge®		Narrow Multiple (3V, 5V, 8V)	1-1000
Double Angle V-Belt		Double V-Belts (AA, BB, CC)	1-200
Vee-Rib™		V-Ribbed (J)	4-500
Gold-Ribbon® Cog-Band®		Classical Cogged Banded (RBX, RCX)	1-500
Power-Wedge® Cog-Band®		Narrow Cogged Banded (R3VX, R5VX)	1-1000
Super Power-Wedge® Band		Narrow Banded (R3V, R5V, R8V)	1-1000
Aramax® Power-Wedge® Band		Narrow Banded (R5VK, R8VK)	1-2000
Chipper Drive Wedge-Band®		Narrow Banded (R5VL)	1-600
Super Blue Ribbon® Band		Classical Banded (RB, RC, RD)	1-500
Durapower®II		FHP (2L, 3L, 4L, 5L)	Light Duty
Dry-Can Belt		Double Angle (CC-S)	1-500
Thoro-Twist™		Link (3L, A, B, C)	1-300
Round Belts		Round (716R, 916R)	1-200

 This symbol indicates product manufactured to **chekmate** tolerances.

V-Belt Installation Check List & Selection Guide

Maximum Belt Speed (FT/Min) ⁽¹⁾	Normal Temperature Range (°F) ⁽²⁾		Oil/Heat Resistance	Static Dissipating	General Application
	Min.	Max.			
6500	-50	250	Good	✓	Longer life, high efficiency, small diameters
6500	-50	250	Good	✓	General purpose heavy duty industrial drives
6500	-35	120	Good	✓	General purpose heavy duty industrial drives
6500	-35	120	Good	No	General purpose heavy duty industrial drives
6500	-50	250	Good	✓	High-performance, compact industrial drives
6500	-50	250	Good	✓	High-performance, compact industrial drives
6500	-35	130	Very Good	✓	High-performance, compact industrial drives
6500	-35	120	Good	Special Order Only	Serpentine drives
6500	-35	130	Very Good	No	Small diameters, high speed ratios, compact
6500	-35	130	Good	✓	Longer life, high efficiency, reduces belt whip, turnover on pulsating surge loads
6500	-35	130	Good	✓	Eliminates belt whip and turnover
6500	-35	130	Very Good	✓	Eliminates belt whip and turnover
6500	-35	130	Very Good	✓	Heavy duty, high load machinery
6500	-35	130	Very Good	Special Order Only	Chipper drives
6500	-35	120	Good	✓	Eliminates belt whip and turnover
6500	-50	250	Fair	✓	Using a single belt/low load/small HVAC
6500	-35	120	Good	Special Order Only	Dry-Can applications
5000 (1000 min.)	-35	130	Excellent	No	Emergency replacement, fixed center distance
6500	-35	130	Good	Special Order Only	Conveyor applications

Notes: (1) Normally limited by sheave materials. (2) Expect moderate life loss due to heat.

V-Belts

Nomenclature

Timken V-Belts Nomenclature

Cross Section	Timken Belts	Part # Example	Part Number Explanation
Wedge V-Belts			
3VX, 5VX, 8VX	Power-Wedge® Cog-Belt®	5VX850	5V = cross section, X = cogged construction, 850 = effective length in tenths of an inch
XPZ, XPA, XPB, XPC	Metric Power-Wedge® Cog-Belt®	XPB2000	X = cogged construction, PB = cross section, 2000 = pitch length in millimeters
3V, 5V, 8V	Super Power-Wedge® V-Belt	5V850	5V = cross section, 850 = effective length in tenths of an inch
SPB, SPC	Metric Super Power-Wedge® V-Belt	SPB2000	SPB = cross section, 2000 = pitch length in millimeters
5VK, 8VK	Aramax® Super Power-Wedge® V-Belt	5VK850	5V = cross section, K = aramid cord, 850 = effective length in tenths of an inch
SPBK, SPCK	Metric Aramax® Super Power-Wedge® V-Belt	SPBK2000	SPB = cross section, K = aramid cord, 2000 = pitch length in millimeters
Classical V-Belts			
AX, BX, CX, DX	Gold-Ribbon® Cog-Belt®	BX85	B = cross section, X = cogged construction, 85 = inside circumference in inches
A-R, B-R, C-R	Super II® V-Belt	B85R	B = cross section, 85 = inside circumference in inches, R = raw edge construction
A, B, C, D, E	Super Blue Ribbon® V-Belt	B85	B = cross section, 85 = inside circumference in inches
3L-K, AK, BK	Aramax® Xtra Duty V-Belt	BK95	B = cross section, K = aramid cord construction, 85 = inside circumference in inches
Double Angle V-Belts			
AA, BB, CC	Double Angle V-Belt	BB85	BB = cross section, 85 = inside circumference in inches
FHP V-Belts			
2L-R, 3L-R, 4L-R, 5L-R	Durapower® II FHP V-Belt	4L400R	4L = cross section, 400 = outside length in tenths of inch, R = raw edge construction
Variable Speed V-Belts			
V	Variable Speed Cog-Belt®	1228V255	12 = top width in 16th of an inch, 28 = pulley angle, V = variable speed, 255 = pitch length in 10th of an inch
V-Ribbed Belts			
J	Vee-Rib™ Belt	490J8	490 = effective length in inches, J = cross section, 8 = number of ribs

Power-Wedge® Cog-Belt®

V-Belt



- 1 Oversized Polyester Cord**
High-modulus cord carries the horsepower load with minimum stretch. Specially treated to produce a long-lasting bond with the surrounding rubber assuring longer belt life. Adds belt strength and stability during peak shock loads.
- 2 Precision Molded Cogs**
Improves flexibility and reduces stress that enables the belt to bend more easily around the pulley. It runs cooler – less heat equals longer belt life. Smaller pulley diameters mean lower cost and space savings.

- 3 EPDM Construction**
Offers superior flex and load carrying capacity at high and low temperatures. EPDM is durable, static conductive and resistant to heat, hardening and glazing.
- 4 Raw Edge Side Walls**
Produce a higher coefficient of friction and minimizes slippage. The gripping power provides higher energy efficiency and reduces vibration for extended component life. The raw edge construction also allows more cord width for increased horsepower capacity.

Recommended Sheaves:
Hi-Cap Wedge – QD, Taper Bushed, or MST (3V, 5V, 8V)

Energy efficient

Smooth running

Design flexibility

High performance
EPDM construction:

- High HP ratings
- Long belt life
- Oil and heat resistant
- Resists hardening and glazing
- Broad operating temperature range (-50°F to +250°F)

chekmate®

Static conductive

Imperial and metric cross-sections

Applications:

- Fans
- Pumps
- HVAC
- Compressors & More

Power-Wedge® Cog-Belt®

V-Belt

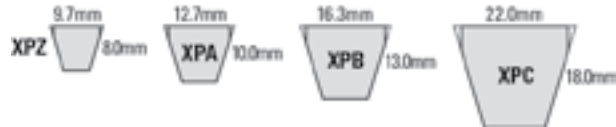
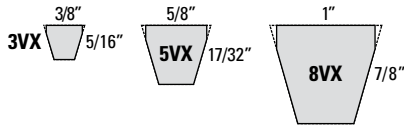

The Power-Wedge® Cog-Belt® combines the advantages of EPDM, the narrow belt wedge design and raw edge performance for maximum operating efficiency in a compact drive package.

More Grip... Less Slip

Our Power-Wedge® Cog-Belt® provides more torque with little or no slippage. The result is savings – in time, in belt life and in energy costs.

The narrow profile permits reduced drive widths and a smaller drive envelope. Higher horsepower ratings translate into greater design flexibility – reducing drive cost, space and weight.

Belts are made of Ethylene Propylene Diene Monomer (EPDM), a synthetic rubber that is durable and resistant to oil, heat, hardening and glazing. Timken belts made of EPDM have superior flex and load carrying capacity with a broad operating temperature range of -50°F to +250°F.

The Power-Wedge Cog-Belt is available in 3VX, 5VX, and 8VX cross sections as well as metric sizes XPZ, XPA, XPB, and XPC. Where applicable, belts are dual branded with imperial and metric part numbers.



Horsepower Ratings Comparison

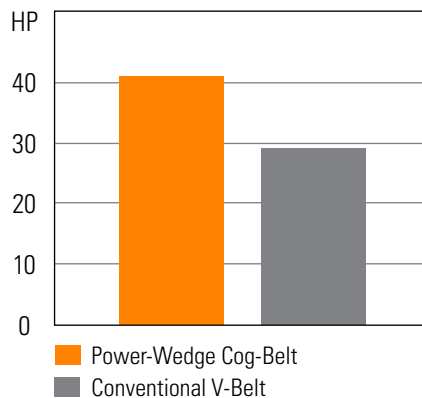

5V Section Drive
1750 RPM
1.5:1 Belt Drive Ratio

Power-Wedge® Cog-Belt®

V-Belt

Power-Wedge® Cog-Belt® Part Numbers

Part Number Example: **5VX500** = **5V** **X** **500**
Cross Section Cogged Construction Effective Length (inches in tenths: 50.0")

Part Number	Outside Circumference (inches)	Outside Circumference (mm)	Weight (lbs.)
3V Section – Recommended Sheaves: Hi-Cap Wedge – QD, Taper Bushed, or MST (3V)			
3VX250	25.4	645	0.1
3VX265	27	686	0.1
3VX280	28.5	724	0.1
3VX300	30.4	772	0.1
3VX310	31.7	805	0.1
3VX315	32	813	0.1
3VX335	33.8	859	0.1
3VX355	36.1	917	0.1
3VX365	37	940	0.1
3VX375	38	965	0.1
3VX400	40.5	1029	0.1
3VX425	43	1092	0.1
3VX450	45.6	1158	0.1
3VX475	48	1219	0.1
3VX500	50.5	1283	0.2
3VX530	53.4	1356	0.2
3VX540	54.1	1374	0.2
3VX550	55.9	1420	0.2
3VX560	56.5	1435	0.2
3VX580	58.4	1483	0.2
3VX590	59.6	1514	0.2
3VX600	60.6	1539	0.2
3VX630	63.4	1610	0.2
3VX650	65.6	1666	0.2
3VX670	67.5	1715	0.2
3VX690	69.4	1763	0.2
3VX710	71.6	1819	0.2
3VX750	75.3	1913	0.2
3VX800	80.4	2042	0.3
3VX820	82.6	2098	0.4
3VX850	85.4	2169	0.3
3VX900	90.4	2296	0.3

Part Number	Outside Circumference (inches)	Outside Circumference (mm)	Weight (lbs.)
3V Section – Recommended Sheaves: Hi-Cap Wedge – QD, Taper Bushed, or MST (3V)			
3VX950	95.5	2426	0.3
3VX1000	100.5	2553	0.3
3VX1027	103	2616	0.3
3VX1060	106.4	2703	0.3
3VX1120	112.4	2855	0.4
3VX1180	118.4	3007	0.4
3VX1250	125.5	3188	0.4
3VX1280	128.5	3264	0.4
3VX1320	132.5	3366	0.4
3VX1360	136.5	3467	0.4
3VX1400	140.5	3569	0.4
3VX1500	150.5	3823	0.5
5V Section – Recommended Sheaves: Hi-Cap Wedge – QD, Taper Bushed, or MST (5V)			
5VX450	45.5	1156	0.4
5VX470	47.4	1204	0.4
5VX490	49.5	1257	0.4
5VX500	50.5	1283	0.4
5VX510	51.5	1308	0.4
5VX530	53.6	1361	0.4
5VX540	54.4	1382	0.4
5VX550	55.5	1410	0.4
5VX560	56.5	1435	0.5
5VX570	57.4	1458	0.5
5VX580	58.4	1483	0.5
5VX590	59.6	1514	0.5
5VX600	60.6	1539	0.6
5VX610	61.5	1562	0.5
5VX630	63.4	1610	0.5
5VX650	65.5	1664	0.5
5VX660	66.5	1689	0.5
5VX670	67.5	1715	0.5

Power-Wedge® Cog-Belt®

V-Belt

Power-Wedge® Cog-Belt® Part Numbers

Part Number Example: **5VX1000** = **5V** **X** **1000**
Cross Section Cogged Construction Effective Length (inches in tenths: 100.0")

Part Number	Outside Circumference (inches)	Outside Circumference (mm)	Weight (lbs.)
5V Section – Recommended Sheaves: Hi-Cap Wedge – QD, Taper Bushed, or MST (5V)			
5VX680	68.4	1737	0.5
5VX690	69.4	1763	0.6
5VX710	71.6	1819	0.6
5VX730	73.5	1867	0.6
5VX740	74.4	1890	0.6
5VX750	75.6	1920	0.6
5VX770	77.5	1969	0.6
5VX780	78.5	1994	0.6
5VX790	79.4	2017	0.6
5VX800	80.4	2042	0.6
5VX810	81.3	2065	0.6
5VX830	83.5	2121	0.7
5VX840	84.4	2144	0.7
5VX850	85.4	2169	0.7
5VX860	86.3	2192	0.7
5VX880	88.5	2248	0.7
5VX900	90.4	2296	0.7
5VX930	93.5	2375	0.7
5VX950	95.4	2423	0.8
5VX960	96.3	2446	0.8
5VX990	99.5	2527	0.8
5VX1000	100.5	2553	0.8
5VX1030	103.3	2624	0.8
5VX1060	106.4	2703	0.9
5VX1080	108.6	2758	0.9
5VX1120	112.4	2855	0.9
5VX1150	115.5	2934	0.9
5VX1160	116.8	2967	0.9
5VX1180	118.6	3012	0.9
5VX1200	120.5	3061	1.0
5VX1230	123.5	3137	1.0
5VX1250	125.5	3188	1.0

Part Number	Outside Circumference (inches)	Outside Circumference (mm)	Weight (lbs.)
5V Section – Recommended Sheaves: Hi-Cap Wedge – QD, Taper Bushed, or MST (5V)			
5VX1320	132.5	3366	1.1
5VX1400	140.5	3569	1.1
5VX1500	150.5	3823	1.2
5VX1600	160.5	4077	1.3
5VX1700	170.5	4331	1.4
5VX1800	180.5	4585	1.4
5VX1900	190.5	4839	1.5
5VX2000	200.5	5093	1.6
8V Section – Recommended Sheaves: Hi-Cap Wedge – QD, Taper Bushed, or MST (8V)			
8VX1000	100.5	2553	2.3
8VX1060	106.5	2705	2.5
8VX1120	112.5	2858	2.6
8VX1180	118.5	3010	2.8
8VX1250	125.5	3188	2.9
8VX1320	132.5	3366	3.1
8VX1400	140.5	3569	3.3
8VX1500	150.5	3823	3.5
8VX1600	160.5	4077	3.7
8VX1700	170.5	4331	4.0
8VX1800	180.5	4585	4.2
8VX1900	190.5	4839	4.4
8VX2000	200.5	5093	4.5

Power-Wedge® Cog-Band® Banded Belt



1 Oversized Polyester Cord
High-modulus cord carries the horsepower load with minimum stretch. Specially treated to produce a long-lasting bond with the surrounding rubber assuring longer belt life. Adds belt strength and stability during peak shock loads.

2 Raw Edge Sidewalls
Produce a higher coefficient of friction and minimizes slippage. The gripping power provides higher energy efficiency and reduces vibration for extended component life.

3 Precision Molded Cogs
Superior flexibility with reduced bending stress helps dissipate heat providing significantly longer belt life. Uses smaller pulley diameters. A cost and space saver.

4 Reinforced Tie-Band
Highly engineered tie-band permanently bonds or "ties" multiple belts together. This assures smooth operation enabling the belts to function as a single unit, with even load distribution and wear. Vibration is dampened. Heavy shock loads are absorbed. Belt whip and turnover are minimized.

5 EPDM
Ethylene Propylene Diene Monomer is a synthetic rubber that is durable and resistant to heat, oil, hardening and glazing. EPDM has superior flex and load carrying capacity with a broad operating temperature range of -50°F to +250°F.

Recommended Pulleys:
Hi-Cap Wedge – QD, Taper Bushed, or MST (3V, 5V)

Banded version of
Power-Wedge Cog-Belt

EPDM raw edge
construction

Minimizes belt whip and
turnover

Higher horsepower than
wrapped belts

Longer belt life than
wrapped belts

Oil and heat resistant

Static dissipating

Applications:

- Fans
- Pumps
- Compressors
& More

Power-Wedge[®] Cog-Band[®]

Banded Belt



Two or more Power-Wedge Cog-Belts are permanently joined together at the top with a reinforced tie-band. Ideally suited for pulsating or heavily shock loaded drives and drives with long center distances to minimize belt whip and rollover.

The Power-Wedge Cog-Band combines the longer life and superior performance of the Power-Wedge Cog-Belt with the stability of a banded belt. The unique construction of Ethylene Propylene Diene Monomer (EPDM) and the superior flexing of precision molded cogs with the tenacious gripping power of raw edge sidewalls provides significantly longer belt life, improved efficiency and higher horsepower ratings than wrapped belts.

EPDM is static conductive, durable, and resistant to heat, hardening, and glazing.

Banded belts assure that each rib is sharing the load equally to achieve the full horsepower capacity of the drive. The reinforced band across the top greatly enhances stability by minimizing belt whip and turnover.

For complete part number, add the number of ribs required. For example: R5VX1000-3.



Horsepower Per Rib Comparison

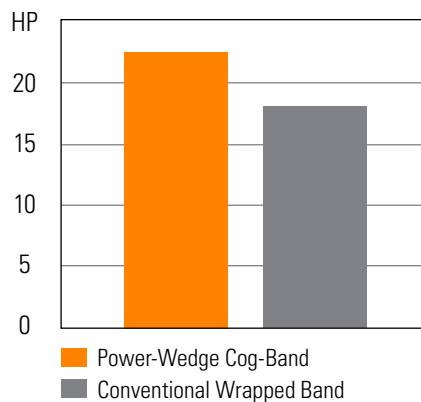

Power-Wedge Cog-Band Matching Limits

Matching limits for Power-Wedge Cog-Band are shown in the table. If the number is 1, the bands must all have the same "sag" number. If the number is 2, a matched set may consist of any 2 adjacent matching numbers, etc.

Product Type and Length Code	Match Limit
Power-Wedge[®] Cog Band	
R3VX250 – R3VX630	1
R3VX670 – R3VX1400	2
R5VX500 – R5VX630	1
R5VX670 – R5VX1500	2
R5VX1600 and up	3

Power-Wedge® Cog-Band® Banded Belt

Power-Wedge® Cog-Band® Part Numbers

Part Number Example: **R5VX1000-3** =

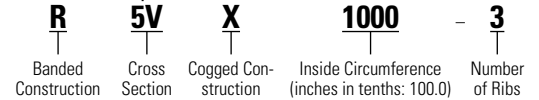

Part Number	Outside Circumference (inches) per rib	Outside Circumference (mm) per rib	Weight (lbs.) per rib
R3VX – Banded 3VX Section Recommended Pulleys: Hi-Cap Wedge – QD, Taper Bushed, or MST (3V)			
R3VX250	26.1	26	0.13
R3VX265	27.6	701	0.14
R3VX280	29.1	739	0.15
R3VX300	31.1	790	0.16
R3VX315	32.6	828	0.16
R3VX335	34.6	879	0.17
R3VX355	36.6	930	0.18
R3VX375	38.6	980	0.19
R3VX400	40.8	1036	0.20
R3VX415	42.3	1074	0.20
R3VX425	43.3	1100	0.21
R3VX440	44.8	1138	0.21
R3VX450	45.8	1163	0.22
R3VX465	47.3	1201	0.23
R3VX475	48.3	1227	0.24
R3VX485	49.3	1252	0.24
R3VX500	50.8	1290	0.25
R3VX530	53.8	1367	0.26
R3VX560	56.8	1443	0.28
R3VX600	60.8	1544	0.30
R3VX630	63.8	1621	0.32
R3VX670	67.8	1722	0.34
R3VX710	71.8	1824	0.36
R3VX750	75.8	1925	0.38
R3VX770	77.8	1976	0.39
R3VX800	80.8	2052	0.40
R3VX820	82.8	2103	0.41
R3VX830	83.8	2129	0.42
R3VX850	85.8	2179	0.43
R3VX900	90.8	2306	0.45
R3VX950	95.8	2433	0.48
R3VX1000	100.8	2560	0.51
R3VX1060	106.8	2713	0.54
R3VX1120	112.8	2865	0.57
R3VX1180	118.8	3018	0.60

Part Number	Outside Circumference (inches) per rib	Outside Circumference (mm) per rib	Weight (lbs.) per rib
R3VX – Banded 3VX Section Recommended Pulleys: Hi-Cap Wedge – QD, Taper Bushed, or MST (3V)			
R3VX1250	125.8	3195	0.63
R3VX1320	132.8	3373	0.67
R3VX1400	140.8	3576	0.71
R5VX – Banded 5VX Section Recommended Pulleys: Hi-Cap Wedge – QD, Taper Bushed, or MST (5V)			
R5VX500	50.8	1290	0.63
R5VX530	53.8	1367	0.66
R5VX560	56.8	1443	0.70
R5VX600	60.8	1544	0.76
R5VX630	63.8	1621	0.80
R5VX670	67.8	1722	0.85
R5VX710	71.8	1824	0.90
R5VX750	75.8	1925	0.95
R5VX800	80.8	2052	1.02
R5VX850	85.8	2179	1.08
R5VX900	90.8	2306	1.15
R5VX950	95.8	2433	1.22
R5VX1000	100.8	2560	1.28
R5VX1030	104.1	2644	1.30
R5VX1060	106.8	2713	1.36
R5VX1120	112.8	2865	1.44
R5VX1180	118.8	3018	1.52
R5VX1200	121.1	3076	1.58
R5VX1250	125.8	3195	1.61
R5VX1320	132.8	3373	1.70
R5VX1400	140.8	3576	1.80
R5VX1460	147.1	3736	1.90
R5VX1500	150.8	3830	1.94
R5VX1600	160.8	4084	2.07
R5VX1700	170.8	4338	2.20
R5VX1800	180.8	4592	2.33
R5VX1900	190.8	4846	2.46
R5VX2000	200.8	5100	2.59

For complete part number, add number of ribs required as indicated in example above.

Metric Power-Wedge® Cog-Belt®

V-Belt

Metric Power-Wedge® Cog-Belt® Part Numbers

Part Number Example: **XPZ1000** = **X** **PZ** **1000**
Cogged Construction Cross Section Pitch Length (millimeters)

Part Number	Legacy Part Number	Outside Circumference (inches)	Outside Circumference (mm)	Weight (lbs.)
XPZ Section – Recommended Sheaves: Hi-Cap Wedge – OD, Taper Bushed, or MST (3V)				
XPZ1000	SPZX1000	39.8	1011	0.2
XPZ1010	SPZX1010	40.5	1029	0.2
XPZ1030	SPZX1030	41.1	1044	0.2
XPZ1060	SPZX1060	42.4	1077	0.2
XPZ1080	SPZX1080	43	1092	0.2
XPZ1090	SPZX1090	43.6	1107	0.2
XPZ1120	SPZX1120	44.9	1141	0.2
XPZ1140	SPZX1140	45.6	1158	0.2
XPZ1150	SPZX1150	45.8	1163	0.2
XPZ1180	SPZX1180	47.1	1196	0.2
XPZ1200	SPZX1200	48	1219	0.2
XPZ1220	SPZX1220	48.6	1234	0.2
XPZ1250	SPZX1250	49.9	1268	0.2
XPZ1270	SPZX1270	50.5	1283	0.2
XPZ1280	SPZX1280	51.2	1301	0.2
XPZ1312	SPZX1312	52.1	1323	0.2
XPZ1320	SPZX1320	52.7	1339	0.2
XPZ1340	SPZX1340	53.4	1356	0.2
XPZ1360	SPZX1360	54.1	1374	0.2
XPZ1400	SPZX1400	55.9	1420	0.2
XPZ1420	SPZX1420	56.5	1435	0.3
XPZ1450	SPZX1450	57.8	1468	0.3
XPZ1470	SPZX1470	58.4	1483	0.3
XPZ1500	SPZX1500	59.6	1514	0.3
XPZ1520	SPZX1520	60.6	1539	0.2
XPZ1537	SPZX1537	61.2	1555	0.2
XPZ1560	SPZX1560	62.2	1580	0.3
XPZ1587	SPZX1587	63.1	1603	0.2
XPZ1600	SPZX1600	63.4	1610	0.3
XPZ1612	SPZX1612	64	1626	0.2
XPZ1650	SPZX1650	65.6	1666	0.3
XPZ1662	SPZX1662	65.9	1674	0.2
XPZ1700	SPZX1700	67.5	1715	0.3

Part Number	Legacy Part Number	Outside Circumference (inches)	Outside Circumference (mm)	Weight (lbs.)
XPZ Section – Recommended Sheaves: Hi-Cap Wedge – OD, Taper Bushed, or MST (3V)				
XPZ1750	SPZX1750	69.4	1763	0.3
XPZ1800	SPZX1800	71.6	1819	0.3
XPZ1850	SPZX1850	73.5	1867	0.2
XPZ1862	SPZX1862	73.8	1875	0.2
XPZ1900	SPZX1900	75.3	1913	0.3
XPZ1950	SPZX1950	77.2	1961	0.3
XPZ2000	SPZX2000	79.4	2017	0.2
XPZ2030	SPZX2030	80.4	2042	0.4
XPZ2120	SPZX2120	84.1	2136	0.3
XPZ2160	SPZX2160	85.4	2169	0.4
XPZ2240	SPZX2240	88.9	2258	0.3
XPZ2280	SPZX2280	90.4	2296	0.4
XPZ2360	SPZX2360	93.6	2377	0.3
XPZ2410	SPZX2410	95.5	2426	0.4
XPZ2500	SPZX2500	99.1	2517	0.3
XPZ2540	SPZX2540	100.5	2553	0.4
XPZ2650	SPZX2650	105	2667	0.3
XPZ2670	SPZX2670	105.8	2687	0.3
XPZ2690	SPZX2690	106.4	2703	0.5
XPZ2800	SPZX2800	110.9	2817	0.3
XPZ2840	SPZX2840	112.4	2855	0.5
XPZ3000	SPZX3000	118.4	3007	0.5
XPZ3150	SPZX3150	124.7	3167	0.4
XPZ3170	SPZX3170	125.5	3188	0.4
XPZ3350	SPZX3350	132.5	3366	0.4
XPZ3550	SPZX3550	140.5	3569	0.4
XPZ3810	SPZX3810	150.5	3823	0.5
XPZ630	SPZX630	25.4	645	0.1
XPZ670	SPZX670	27	686	0.1
XPZ710	SPZX710	28.5	724	0.1
XPZ750	SPZX750	30.1	765	0.1
XPZ760	SPZX760	30.4	772	0.1
XPZ787	SPZX787	31.7	805	0.1

Metric Power-Wedge® Cog-Belt®

V-Belt

Metric Power-Wedge® Cog-Belt® Part Numbers

Part Number Example: **XPA2000** = **X** **PA** **2000**
Cogged Construction Cross Section Pitch Length (millimeters)

Part Number	Legacy Part Number	Outside Circumference (inches)	Outside Circumference (mm)	Weight (lbs.)
XPZ Section – Recommended Sheaves: Hi-Cap Wedge – QD, Taper Bushed, or MST (3V)				
XPZ800	SPZX800	32	813	0.1
XPZ850	SPZX850	33.8	859	0.1
XPZ875	SPZX875	35.1	892	0.2
XPZ900	SPZX900	36.1	917	0.2
XPZ925	SPZX925	37	940	0.2
XPZ940	SPZX940	37.6	955	0.2
XPZ950	SPZX950	38	965	0.2
XPA Section – Recommended Sheaves: Hi-Cap Wedge – QD, Taper Bushed, or MST (3V, 5V, 8V)				
XPA1000	SPAX1000	40.2	1021	0.3
XPA1030	SPAX1030	41.1	1044	0.3
XPA1060	SPAX1060	42.4	1077	0.3
XPA1090	SPAX1090	43.6	1107	0.3
XPA1120	SPAX1120	44.9	1141	0.3
XPA1150	SPAX1150	45.8	1163	0.3
XPA1157	SPAX1157	46.1	1171	0.3
XPA1180	SPAX1180	47.1	1196	0.3
XPA1220	SPAX1220	48.6	1234	0.4
XPA1232	SPAX1232	49.2	1250	0.3
XPA1250	SPAX1250	49.9	1268	0.4
XPA1280	SPAX1280	51.2	1301	0.4
XPA1307	SPAX1307	52.1	1323	0.3
XPA1320	SPAX1320	52.7	1339	0.4
XPA1357	SPAX1357	54.1	1374	0.3
XPA1360	SPAX1360	54.3	1379	0.4
XPA1400	SPAX1400	55.9	1420	0.4
XPA1450	SPAX1450	57.8	1468	0.4
XPA1457	SPAX1457	58.1	1476	0.3
XPA1500	SPAX1500	59.6	1514	0.4
XPA1532	SPAX1532	60.9	1547	0.4
XPA1550	SPAX1550	61.8	1570	0.4
XPA1557	SPAX1557	61.8	1570	0.4
XPA1600	SPAX1600	63.7	1618	0.5

Part Number	Legacy Part Number	Outside Circumference (inches)	Outside Circumference (mm)	Weight (lbs.)
XPA Section – Recommended Sheaves: Hi-Cap Wedge – QD, Taper Bushed, or MST (3V, 5V, 8V)				
XPA1650	SPAX1650	65.6	1666	0.5
XPA1700	SPAX1700	67.5	1715	0.5
XPA1750	SPAX1750	69.7	1770	0.5
XPA1757	SPAX1757	70	1778	0.3
XPA1782	SPAX1782	70.9	1801	0.3
XPA1800	SPAX1800	71.6	1819	0.4
XPA1832	SPAX1832	72.8	1849	0.4
XPA1850	SPAX1850	73.5	1867	0.4
XPA1900	SPAX1900	75.3	1913	0.4
XPA1932	SPAX1932	76.6	1946	0.4
XPA1950	SPAX1950	77.5	1969	0.4
XPA1957	SPAX1957	77.9	1979	0.4
XPA1982	SPAX1982	78.8	2002	0.4
XPA2000	SPAX2000	79.4	2017	0.4
XPA2032	SPAX2032	80.7	2050	0.4
XPA2057	SPAX2057	81.6	2073	0.4
XPA2060	SPAX2060	81.8	2078	0.4
XPA2082	SPAX2082	82.6	2098	0.5
XPA2120	SPAX2120	84.1	2136	0.4
XPA2160	SPAX2160	85.7	2177	0.4
XPA2180	SPAX2180	86.5	2197	0.4
XPA2182	SPAX2182	86.7	2202	0.4
XPA2240	SPAX2240	88.9	2258	0.4
XPA2282	SPAX2282	90.6	2301	0.4
XPA2300	SPAX2300	91.4	2322	0.4
XPA2307	SPAX2307	91.4	2322	0.6
XPA2360	SPAX2360	93.6	2377	0.5
XPA2430	SPAX2430	96.4	2449	0.6
XPA2432	SPAX2432	96.4	2449	0.5
XPA2482	SPAX2482	98.3	2497	0.5
XPA2500	SPAX2500	99.2	2520	0.5
XPA2532	SPAX2532	100.5	2553	0.5
XPA2582	SPAX2582	102.4	2601	0.5

Metric Power-Wedge® Cog-Belt®

V-Belt

Part Number Example: **XPB2000** = **X** **PB** **2000**
Cogged Construction Cross Section Pitch Length (millimeters)

Part Number	Legacy Part Number	Outside Circumference (inches)	Outside Circumference (mm)	Weight (lbs.)
XPA Section – Recommended Sheaves: Hi-Cap Wedge – OD, Taper Bushed, or MST (3V, 5V, 8V)				
XPA2607	SPAX2607	103.3	2624	0.5
XPA2632	SPAX2632	104.3	2649	0.5
XPA2650	SPAX2650	105	2667	0.5
XPA2682	SPAX2682	106.1	2695	0.5
XPA2732	SPAX2732	108.3	2751	0.5
XPA2782	SPAX2782	110.2	2799	0.5
XPA2800	SPAX2800	110.9	2817	0.5
XPA3000	SPAX3000	118.7	3015	0.6
XPA3150	SPAX3150	124.7	3167	0.6
XPA3185	SPAX3185	126.1	3203	0.6
XPA3350	SPAX3350	132.6	3368	0.7
XPA3550	SPAX3550	140.5	3569	0.7
XPA3750	SPAX3750	148.3	3767	0.7
XPA4000	SPAX4000	158.2	4018	0.8
XPA4250	SPAX4250	168	4267	0.8
XPA4500	SPAX4500	177.9	4519	0.9
XPA800	SPAX800	32.3	820	0.2
XPA850	SPAX850	34.2	869	0.2
XPA900	SPAX900	36.1	917	0.3
XPA925	SPAX925	37	940	0.3
XPA950	SPAX950	38	965	0.3
XPA975	SPAX975	39.2	996	0.3
XPB Section – Recommended Sheaves: Hi-Cap Wedge – OD, Taper Bushed, or MST (5V)				
XPB1150	SPBX1150	46.1	1171	0.5
XPB1200	SPBX1200	48.2	1224	0.4
XPB1230	SPBX1230	49.5	1257	0.4
XPB1250	SPBX1250	50.2	1275	0.5
XPB1260	SPBX1260	50.5	1283	0.4
XPB1320	SPBX1320	53	1346	0.6
XPB1340	SPBX1340	53.6	1361	0.6
XPB1360	SPBX1360	54.4	1382	0.6
XPB1370	SPBX1370	54.9	1395	0.6

Part Number	Legacy Part Number	Outside Circumference (inches)	Outside Circumference (mm)	Weight (lbs.)
XPB Section – Recommended Sheaves: Hi-Cap Wedge – OD, Taper Bushed, or MST (3V, 5V, 8V)				
XPB1400	SPBX1400	55.5	1410	0.6
XPB1410	SPBX1410	56.5	1435	0.5
XPB1430	SPBX1430	57.4	1458	0.5
XPB1450	SPBX1450	58.1	1476	0.5
XPB1500	SPBX1500	59.9	1522	0.7
XPB1510	SPBX1510	60.6	1539	0.7
XPB1525	SPBX1525	60.9	1547	0.5
XPB1550	SPBX1550	61.8	1570	0.5
XPB1590	SPBX1590	63.4	1610	0.5
XPB1600	SPBX1600	64	1626	0.7
XPB1650	SPBX1650	65.9	1674	0.7
XPB1700	SPBX1700	67.8	1722	0.8
XPB1750	SPBX1750	69.4	1763	0.8
XPB1800	SPBX1800	71.6	1819	0.8
XPB1850	SPBX1850	73.8	1875	0.6
XPB1900	SPBX1900	75.6	1920	0.8
XPB1970	SPBX1970	78.5	1994	0.9
XPB2000	SPBX2000	79.4	2017	0.9
XPB2020	SPBX2020	80.4	2042	0.9
XPB2040	SPBX2040	81.3	2065	0.7
XPB2060	SPBX2060	81.9	2080	0.7
XPB2120	SPBX2120	84.4	2144	0.9
XPB2150	SPBX2150	85.4	2169	1.0
XPB2180	SPBX2180	86.6	2200	0.7
XPB2240	SPBX2240	89.2	2266	0.7
XPB2280	SPBX2280	90.4	2296	1.0
XPB2360	SPBX2360	93.9	2385	0.7
XPB2410	SPBX2410	95.4	2423	1.1
XPB2440	SPBX2440	97.1	2466	0.8
XPB2500	SPBX2500	99.5	2527	1.1
XPB2530	SPBX2530	100.5	2553	1.1
XPB2600	SPBX2600	103.3	2624	1.2
XPB2610	SPBX2610	103.6	2631	0.8

Metric Power-Wedge® Cog-Belt®

V-Belt

Metric Power-Wedge® Cog-Belt® Part Numbers

Part Number Example: **XPC2000** = **X** **PC** **2000**
Cogged Construction Cross Section Pitch Length (millimeters)

Part Number	Legacy Part Number	Outside Circumference (inches)	Outside Circumference (mm)	Weight (lbs.)
XPB Section – Recommended Sheaves: Hi-Cap Wedge – QD, Taper Bushed, or MST (3V, 5V, 8V)				
XPB2650	SPBX2650	105.3	2675	0.8
XPB2680	SPBX2680	106.4	2703	0.9
XPB2730	SPBX2730	108.6	2758	1.3
XPB2740	SPBX2740	108.9	2766	0.9
XPB2800	SPBX2800	111.2	2825	0.9
XPB2840	SPBX2840	112.4	2855	1.3
XPB2900	SPBX2900	115.2	2926	0.9
XPB2910	SPBX2910	115.5	2934	1.3
XPB2920	SPBX2920	116	2946	0.9
XPB2990	SPBX2990	118.7	3015	1.4
XPB3000	SPBX3000	119	3023	1.0
XPB3150	SPBX3150	125	3175	1.0
XPB3170	SPBX3170	125.5	3188	1.0
XPB3250	SPBX3250	128.9	3274	1.0
XPB3350	SPBX3350	132.5	3366	1.1
XPB3550	SPBX3550	140.5	3569	1.1
XPB3650	SPBX3650	144.7	3675	1.6
XPB3750	SPBX3750	148.6	3774	1.2
XPB3800	SPBX3800	150.5	3823	1.2
XPB3870	SPBX3870	153.4	3896	1.2
XPB4000	SPBX4000	158.5	4026	1.3
XPB4060	SPBX4060	160.5	4077	1.3
XPB4250	SPBX4250	168.3	4275	1.3
XPB4310	SPBX4310	170.5	4331	1.4
XPB4500	SPBX4500	178.2	4526	1.4
XPB4560	SPBX4560	180.5	4585	1.4
XPB4750	SPBX4750	188	4775	1.5
XPB4820	SPBX4820	190.5	4839	1.5
XPB5000	SPBX5000	197.8	5024	1.6
XPB5070	SPBX5070	200.5	5093	1.6

Part Number	Legacy Part Number	Outside Circumference (inches)	Outside Circumference (mm)	Weight (lbs.)
XPC Section – Recommended Sheaves: Hi-Cap Wedge – QD, Taper Bushed, or MST (3V, 5V, 8V)				
XPC2000	SPCX2000	80.4	2042	1.4
XPC2120	SPCX2120	85.1	2162	1.5
XPC2240	SPCX2240	89.8	2281	1.6
XPC2360	SPCX2360	94.6	2403	1.7
XPC2500	SPCX2500	100.1	2543	1.8
XPC2650	SPCX2650	106	2692	1.9
XPC2800	SPCX2800	111.9	2842	2.0
XPC3000	SPCX3000	119.8	3043	2.1
XPC3150	SPCX3150	125.7	3193	2.2
XPC3350	SPCX3350	133.5	3391	2.4
XPC3550	SPCX3550	141.4	3592	2.5
XPC3750	SPCX3750	149.3	3792	2.6
XPC4000	SPCX4000	159.1	4041	2.8
XPC4250	SPCX4250	169	4293	3.0
XPC4500	SPCX4500	178.8	4542	3.2
XPC4650	SPCX4650	184.7	4691	3.3
XPC4750	SPCX4750	188.6	4790	3.3
XPC5000	SPCX5000	198.5	5042	3.5

Super Power-Wedge®

V-Belt



Super Power-Wedge® V-Belt



1 Oversized Polyester Cord
High-modulus cord carries the horsepower load with minimum stretch. Specially treated to produce a long-lasting bond with the surrounding rubber assuring longer belt life. Adds belt strength and stability during peak shock loads.

2 Tension Section
Synthetic rubber specially formulated to stretch as the belt bends around the sheaves.

3 Compression Section
Synthetic rubber compound designed to support the cords evenly and compress while bending around the sheaves.

4 Heavy Duty Cover
Stress-relieved fabric impregnated with engineered rubber compounds protects the core and assures a smooth transfer of power. Resistant to oil, heat, and environmental conditions.

Recommended Sheaves:
Hi-Cap Wedge – QD, Taper Bushed, or MST (3V, 5V, 8V)

Smooth transfer of power

Design flexibility

Long belt life

Wear resistant

checkmate®

Applications:

Pumps

Mixers

& More

Synchronous Belts

V-Belts

Specialty Belts

Tools

General Information

Super Power-Wedge®

V-Belt

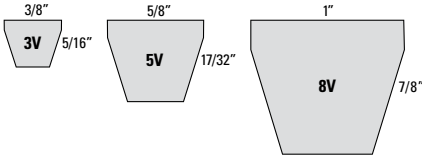

Super Power-Wedge® v-belts enables the design of a more compact belt drive with controlled power transfer. The cover provides superior wear resistance and is ideal for heavy duty industrial drives with shock loads.

The narrow wrapped molded v-belt is perfect for use in applications where cog-belts are too aggressive. It also allows more compact design on multiple belt drives. The stress-relieved fabric-wrapped cover provides outstanding resistance to oil, heat, grease and ozone. Oversized high-modulus cord carries the horsepower load with minimum stretch. Adds belt strength and stability during peak shock loads.

- Made of specially formulated rubber compounds
- Heavy duty cover protects against harsh environmental conditions
- Provides excellent static dissipation
- Proven wedge cross section assures stability when heavy shock loads are encountered
- Delivers an ideal balance between controlled power transfer and slippage
- Reduces cost and space on multiple belt drives
- Ideal for clutching applications
- Long belt life
- Built to Chek Mate belt tolerances for a matched set



Super Power-Wedge® V-Belt

Super Power-Wedge® Part Numbers

Part Number Example: **3V1000** = **3V** **1000**
Cross Section Effective Length
 (inches in tenths: 100.0")

Part Number	Outside Circumference (inches)	Outside Circumference (mm)	Weight (lbs.)
3V Section – Recommended Sheaves: Hi-Cap Wedge – QD, Taper Bushed, or MST (3V)			
3V265	26.8	680	0.1
3V335	33.8	858	0.1
3V355	35.8	909	0.1
3V375	37.8	960	0.1
3V450	45.3	1150	0.2
3V475	47.8	1213	0.2
3V560	56.2	1428	0.2
3V630	63.2	1606	0.2
3V800	80.2	2036	0.3
3V850	85.2	2163	0.3
3V900	90.2	2290	0.3
3V1000	100.1	2543	0.4
3V1060	106.1	2695	0.4
3V1250	125	3176	0.5
3V1320	132.4	3362	0.5
3V1400	140.4	3566	0.5



Super Power-Wedge®

V-Belt

Super Power-Wedge® Part Numbers

Part Number Example: **5V1000** = **5V** **1000**
Cross Section Effective Length (inches in tenths: 100.0")

Part Number	Outside Circumference (inches)	Outside Circumference (mm)	Weight (lbs.)
5V Section – Recommended Sheaves: Hi-Cap Wedge – OD, Taper Bushed, or MST (5V)			
5V500	50.5	1283	0.6
5V530	53.6	1361	0.6
5V560	56.6	1438	0.7
5V600	60.6	1539	0.7
5V630	63.5	1613	0.7
5V670	67.5	1715	0.8
5V710	71.6	1819	0.8
5V750	75.5	1918	0.9
5V800	80.5	2045	0.9
5V850	85.5	2172	1.0
5V900	90.5	2299	1.1
5V950	95.5	2426	1.1
5V1000	100.4	2550	1.2
5V1060	106.6	2708	1.3
5V1120	112.5	2858	1.3
5V1180	118.3	3005	1.4
5V1250	125.7	3193	1.5
5V1320	132.5	3366	1.6
5V1400	140.4	3566	1.7
5V1500	150.5	3823	1.7
5V1600	160.5	4077	1.8
5V1700	170.5	4331	2.0
5V1800	180.5	4585	2.1
5V1900	190.5	4839	2.2
5V2000	200.5	5093	2.3
5V2090	209.5	5321	2.3
5V2120	212.5	5398	2.4
5V2200	221	5613	2.5
5V2210	221.5	5626	2.5
5V2240	224.5	5702	2.6
5V2360	236.5	6007	2.7
5V2365	237	6020	2.7
5V2485	249	6325	2.8
5V2500	250.5	6363	2.9
5V2640	264.5	6718	3.0
5V2650	265.5	6744	3.0
5V2800	280.5	7125	3.2

Part Number	Outside Circumference (inches)	Outside Circumference (mm)	Weight (lbs.)
5V Section – Recommended Sheaves: Hi-Cap Wedge – OD, Taper Bushed, or MST (5V)			
5V3000	300.5	7633	3.5
5V3150	315.5	8014	3.6
5V3350	335.5	8522	3.9
5V3550	355.5	9030	4.1
8V Section – Recommended Sheaves: Hi-Cap Wedge – OD, Taper Bushed, or MST (8V)			
8V1000	100.5	2553	3.1
8V1060	106.5	2705	3.3
8V1120	112.5	2858	3.4
8V1180	118.5	3010	3.6
8V1250	125.5	3188	3.8
8V1320	132.5	3366	4.1
8V1400	140.5	3569	4.3
8V1500	150.5	3823	4.6
8V1600	160.5	4077	4.9
8V1700	170.5	4331	5.2
8V1800	180.5	4585	5.5
8V1900	190.5	4839	5.8
8V2000	200.5	5093	6.1
8V2120	212.5	5398	6.5
8V2240	224.5	5702	6.9
8V2360	236.5	6007	7.2
8V2500	250.5	6363	7.7
8V2650	265.5	6744	8.1
8V2800	280.5	7125	8.6
8V3000	300.5	7633	9.2
8V3150	315.5	8014	9.7
8V3350	335.5	8522	10.3
8V3550	355.5	9030	10.9
8V3750	375.5	9538	11.9
8V4000	400.5	10173	12.8
8V4250	425.5	10808	13.6
8V4500	450.5	11443	14.4
8V4750	475.5	12078	15.2
8V5000	500.5	12713	16.0

Super Power-Wedge® Band Banded Belt



1 Oversized Polyester Cord
High-modulus cord carries the horsepower load with minimum stretch. Specially treated to produce a long-lasting bond with the surrounding rubber assuring longer belt life. Adds belt strength and stability during peak shock loads.

2 Heavy Duty Cover
Stress-relieved fabric impregnated with engineered rubber compounds protects the core and assures a smooth transfer of power. Resistant to oil, heat, and environmental conditions.

3 Reinforced Tie-Band
Highly engineered tie-band permanently bonds or "ties" multiple belts together. This assures smooth operation enabling the belts to function as a single unit, with even load distribution and wear. Vibration is dampened. Heavy shock loads are absorbed. Belt whip and turnover are minimized.

Recommended Pulleys:
Hi-Cap Wedge – QD, Taper Bushed, or MST (3V, 5V, 8V)

Banded version of Super Power-Wedge V-Belt

Wrapped construction

Minimizes whip and turnover on narrow drives

Smooth transfer of power

Space and weight saver

Design flexibility

Long belt life

Wear resistant

Applications:

Pumping units
Rock crushers
Stump grinders
& More

Synchronous Belts

V-Belts

Specialty Belts

Tools

General Information

Super Power-Wedge® Band

Banded Belt

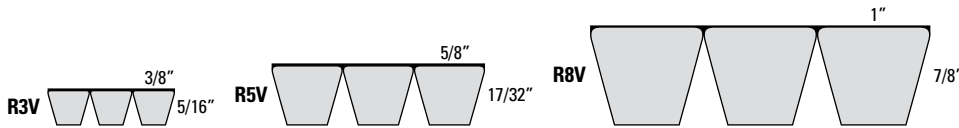

Super Power-Wedge Band is the banded version of the hard-working Super Power-Wedge v-belt. The specially compounded wrapped construction is ideal for clutching operations. Super Power-Wedge Band is oil and heat resistant, staticdissipating, and it won't turn over or jump off the drive.

Two or more Super Power-Wedge belts are permanently joined together at the top with a reinforced tie-band. Banded belts are ideally suited for pulsating or heavily shock loaded drives and drives with long center distances to minimize belt whip and rollover.

Super Power-Wedge Band belts combine the long life and superior performance of the Super Power-Wedge v-belt with the stability of a banded belt. The narrow wedge design saves space and reduces weight.

Banded belts assure that each rib is sharing the load equally to achieve the full horsepower capacity of the drive. The reinforced band across the top greatly enhances stability by minimizing belt whip and turnover.



Features/Advantages

- Minimizes belt whip and rollover on long center distance drives
- Smooth clutching
- Space and weight saver
- Oversized polyester cord provides added belt strength and stability
- Cord is chemically treated for resistance to belt stretch
- Tie-band is highly engineered to permanently bond multiple belts together enabling the belts to function as a single unit with even load distribution and wear
- Vibration is dampened
- Heavy shock loads are absorbed

For complete part number, add the number of ribs required. For example: R5V670-3

Super Power-Wedge Band Matching Limits

Matching limits for Super Power-Wedge Bands are shown in the table. If the number is 1, the bands must all have the same "sag" number. If the number is 2, a matched set may consist of any 2 adjacent matching numbers, etc.

Product Type and Length Code	Match Limit
Super Power-Wedge® Band	
R3V335 – R3V630	1
R3V670 – R3V1400	2
R5V500 – R5V630	1
R5V670 – R5V1500	2
R5VX1600 R5V1600 and up	3
R8V1000 - R8V1500	2
R8V1600 and up	3

Super Power-Wedge® Band Banded Belt

Super Power-Wedge® Band Part Numbers

Part Number Example:

R5V670-3 = **R** **5V** **670** - **3**

Banded Construction
Cross Section
Inside Circumference (inches in tenths: 67.0)
Number of Ribs

Part Number	Outside Circumference (inches)	Outside Circumference (mm)	Weight per Rib (lbs.)
R3V – Banded 3V Section Recommended Pulleys: Hi-Cap Wedge – QD, Taper Bushed, or MST (3V)			
R3V335	34.6	879	0.4
R3V355	36.6	930	0.4
R3V375	38.6	980	0.4
R3V400	41.1	1044	0.5
R3V425	43.6	1107	0.5
R3V450	46.1	1171	0.5
R3V475	48.6	1234	0.6
R3V500	51.1	1298	0.6
R3V530	54.1	1374	0.6
R3V560	57.1	1450	0.7
R3V580	59.1	1501	0.7
R3V600	61.1	1552	0.7
R3V630	64.1	1628	0.7
R3V670	68.1	1730	0.8
R3V700	71.1	1806	1.2
R3V710	72.1	1831	0.8
R3V740	75.1	1908	1.3
R3V750	76.1	1933	0.9
R3V800	81.1	2060	0.9
R3V850	86.1	2187	1.0
R3V900	91.1	2314	1.1
R3V950	96.1	2441	1.1
R3V1000	101.1	2568	1.1
R3V1060	107.1	2720	1.2
R3V1120	113.1	2873	1.3
R3V1180	119.1	3025	1.3
R3V1250	126.1	3203	1.4
R3V1320	133.1	3381	1.5
R3V1400	141.1	3584	1.6

Part Number	Outside Circumference (inches)	Outside Circumference (mm)	Weight per Rib (lbs.)
R5V – Banded 5V Section Recommended Pulleys: Hi-Cap Wedge – QD, Taper Bushed, or MST (5V)			
R5V560	57.1	1450	1.5
R5V600	61.1	1552	1.6
R5V630	64.1	1628	1.7
R5V670	68.1	1730	1.8
R5V670	68.1	1730	9.2
R5V710	72.1	1831	1.9
R5V750	76.1	1933	2.1
R5V800	81.1	2060	2.2
R5V850	86.1	2187	2.3
R5V900	91.1	2314	2.5
R5V950	96.1	2441	2.6
R5V1000	101.1	2568	2.8
R5V1060	107.1	2720	2.9
R5V1120	113.1	2873	3.1
R5V1180	119.1	3025	3.3
R5V1220	123.1	3127	10.4
R5V1250	126.1	3203	3.5
R5V1320	133.1	3381	3.6
R5V1400	141.1	3584	3.9
R5V1500	151.1	3838	4.1
R5V1600	161.1	4092	4.4
R5V1700	171.1	4346	4.7
R5V1800	181.1	4600	5.0
R5V1900	191.1	4854	5.3
R5V2000	201.1	5108	5.5
R5V2120	213.1	5413	5.9
R5V2240	225.1	5718	6.2
R5V2360	237.1	6022	6.5
R5V2480	249.1	6327	17.9
R5V2500	251.1	6378	6.9
R5V2650	266.1	6759	7.3
R5V2800	281.1	7140	7.7
R5V2990	300.3	7628	21.6
R5V3000	301.1	7648	8.3
R5V3150	316.1	8029	8.7
R5V3350	336.1	8537	9.3
R5V3550	356.1	9045	9.8

Super Power-Wedge® Band

Banded Belt

Super Power-Wedge® Band Part Numbers

Part Number	Outside Circumference (inches)	Outside Circumference (mm)	Weight per Rib (lbs.)
R8V – Banded 8V Section Recommended Pulleys: Hi-Cap Wedge – OD, Taper Bushed, or MST (8V)			
R8V1000	101.1	2568	7.1
R8V1060	107.1	2720	7.6
R8V1120	113.1	2873	8.0
R8V1180	119.1	3025	8.4
R8V1250	126.1	3203	9.0
R8V1320	133.1	3381	9.5
R8V1400	141.1	3584	10.0
R8V1500	151.1	3838	10.8
R8V1600	161.1	4092	11.5
R8V1700	171.1	4346	12.2
R8V1800	181.1	4600	12.9
R8V1900	191.1	4854	13.7
R8V2000	201.1	5108	14.4
R8V2120	213.1	5413	15.3
R8V2240	225.1	5718	16.1
R8V2360	237.1	6022	17.0
R8V2500	251.1	6378	18.0
R8V2650	266.1	6759	19.1
R8V2800	281.1	7140	20.2
R8V3000	301.1	7648	21.7
R8V3150	316.1	8029	22.8
R8V3350	336.1	8537	24.2
R8V3550	356.1	9045	25.7
R8V3750	376.1	9553	28.1
R8V4000	401.1	10188	30.0
R8V4250	426.1	10823	31.9
R8V4500	451.1	11458	33.8
R8V4750	476.1	12093	35.7
R8V5000	501.1	12728	37.5
R8V6000	601.1	15268	45.1

Part Number Example:

R8V1000-3 = **R** **8V** **1000** - **3**
 Banded Construction Cross Section Inside Circumference (inches in tenths: 100.0) Number of Ribs



For complete part number, add number of ribs required as indicated in example above.

Metric Super Power-Wedge® V-Belt

Metric Super Power-Wedge® V-Belt Part Numbers

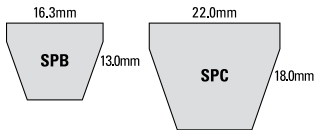

Part Number Example: **SPB3000** = **SPB** **3000**
Cross Section Effective Length (millimeters)

Part Number Example: **SPC4000** = **SPC** **4000**
Cross Section Effective Length (millimeters)

Part Number	Outside Circumference (inches)	Outside Circumference (mm)	Weight (lbs.)
SPB			
SPB2500	99.5	2527	1.1
SPB3000	119	3023	1.5
SPB3150	125	3175	1.5
SPB3350	132.5	3366	1.6
SPB3550	140.5	3569	1.7
SPB3750	148.6	3774	1.8
SPB4000	158.5	4026	2.0
SPB4250	168.3	4275	2.1
SPB4500	178.2	4526	2.2
SPB4750	188	4775	2.3
SPB5000	198.4	5040	2.5
SPB5300	222.9	5663	2.4
SPB5600	249.8	6344	2.6
SPB6000	283.0	7189	2.7
SPB6300	317.0	8052	2.9
SPB6700	358.0	9092	3.1
SPB7100	401.7	10202	3.3
SPB7500	447.6	11370	3.4
SPB8000	503.9	12799	3.7

Part Number	Outside Circumference (inches)	Outside Circumference (mm)	Weight (lbs.)
SPC			
SPC3150	125.7	3193	2.8
SPC3350	133.5	3391	2.9
SPC3550	141.4	3592	3.1
SPC3750	149.3	3792	3.3
SPC4000	159.1	4041	3.5
SPC4250	169	4293	3.7
SPC4500	178.8	4542	3.9
SPC4750	188.6	4790	4.2
SPC5000	198.5	5042	4.4
SPC5300	210.8	5353	4.6
SPC6300	265.0	6732	5.5
SPC6700	297.3	7552	5.9
SPC7100	331.6	8423	6.2
SPC7500	371.9	9447	6.6
SPC8000	498.9	12672	7.0
SPC8500	594.6	15104	7.4
SPC9000	702.2	17837	7.9

Aramax[®] Super Power-Wedge[®]

V-Belt



Aramax® Super Power-Wedge® V-Belt

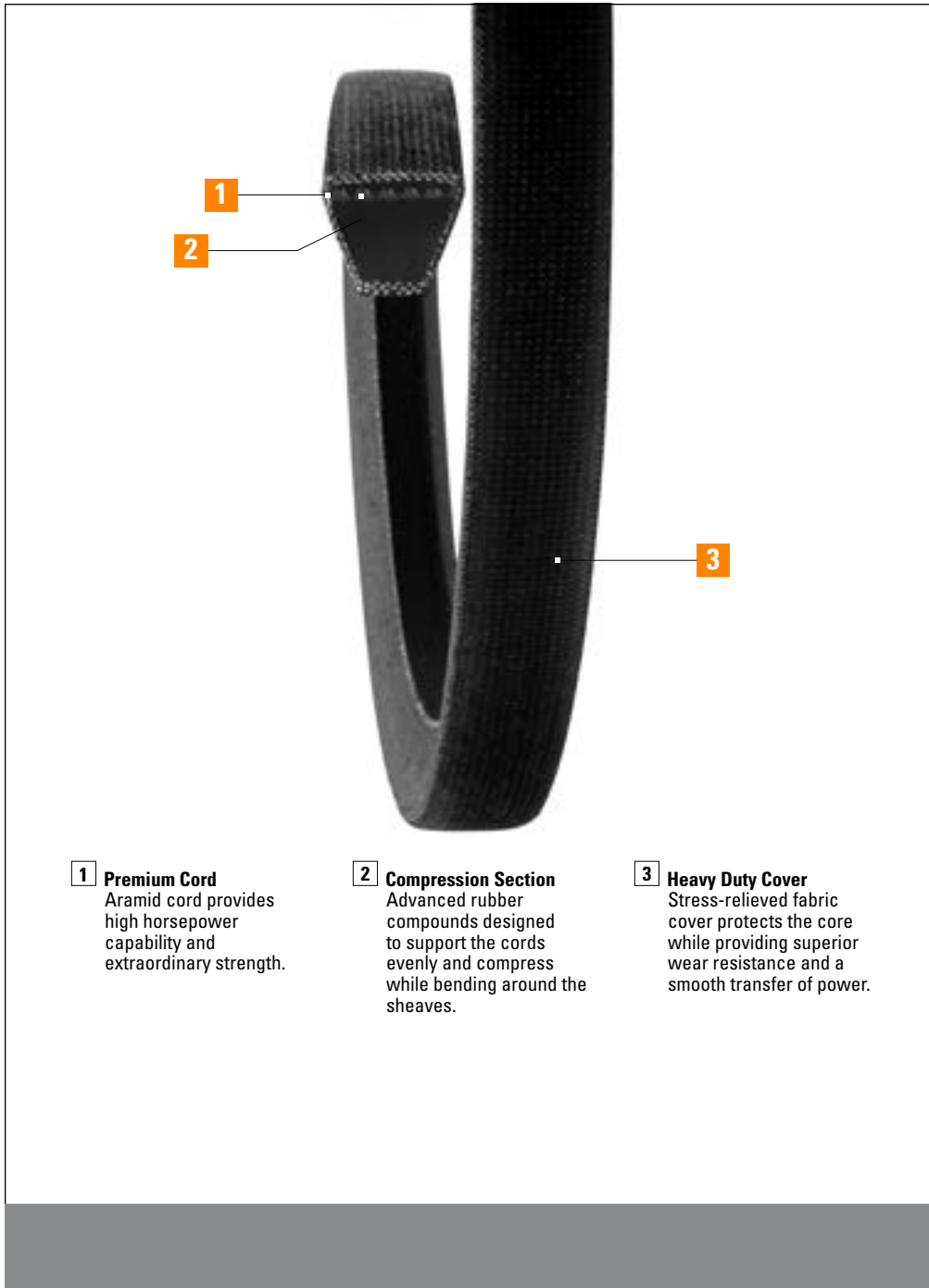

1 Premium Cord
Aramid cord provides high horsepower capability and extraordinary strength.

2 Compression Section
Advanced rubber compounds designed to support the cords evenly and compress while bending around the sheaves.

3 Heavy Duty Cover
Stress-relieved fabric cover protects the core while providing superior wear resistance and a smooth transfer of power.

Controlled power transfer

Extraordinary strength

Long belt life

Static dissipating

Wear resistant

Applications:

Designed for harsh environments like

Aggregates

Oil field

Construction

& More

Aramax[®] Super Power-Wedge[®]

V-Belt

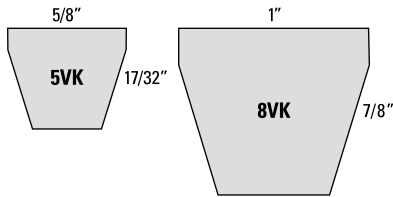

Designed for drives that require super high performance, the Aramax family of Timken belts feature aramid cord for extraordinary strength, durability and high horsepower capability.

The proven deeper cross section provides controlled power transfer in a more compact drive. Aramax Power-Wedge v-belts are ideal for heavy duty industrial drives with shock loads. The stress-relieved fabric cover provides superior wear characteristics and resistance to oil, heat, ozone and other environmental factors. Manufactured to exacting standards for dependability and long life, Aramax Power-Wedge v-belts are made in the USA.

Available in 5VK and 8VK cross sections.

Features/Advantages

- The proven deeper cross-section provides controlled power transfer
- Aramid cord provides high horsepower capability and extraordinary strength on the toughest drives
- Stress-relieved fabric cover provides superior resistance to wear and protects the core
- Meets or exceeds the Association for Rubber Products Manufacturers (ARPM) standards for oil and heat resistance
- Vibration is dampened



Note:

- 5VK has a brown clutching cover and is not static dissipating.
- 8VK has a black cover and is static dissipating.
- When Aramax belts are used as a matched set, all belts in the set must have the same sag number. These high modulus aramid cord belts require closer matching than standard belts in order to tension properly as a set.

Aramax[®] Super Power-Wedge[®] V-Belt

Aramax[®] Super Power-Wedge[®] Part Numbers

Part Number Example:
5VK1000 = **5V** **K** **1000**
Cross Section Aramid Cord Construction Effective Length (inches in tenths: 100.0")

Part Number	Outside Circumference (in)	Outside Circumference (mm)	Weight (lbs.)
5VK			
5VK800	80.5	2044.7	0.9
5VK850	85.5	2171.7	0.9
5VK900	90.5	2298.7	1.0
5VK950	95.5	2425.7	1.1
5VK1000	100.4	2550.2	1.1
5VK1060	106.6	2707.6	1.2
5VK1120	112.5	2857.5	1.2
5VK1180	118.3	3004.8	1.3
5VK1250	112.4	2855.0	1.4
5VK1320	132.5	3365.5	1.5
5VK1400	140.4	3566.2	1.6
5VK1500	150.6	3825.2	1.7
5VK1600	160.6	4079.2	1.8
5VK1700	170.6	4333.2	1.9
5VK1800	180.6	4587.2	2.0
5VK1900	190.6	4841.2	2.1
5VK2000	200.6	5095.2	2.2
5VK2120	212.5	5397.5	2.3
5VK2240	224.6	5704.8	2.5
5VK2360	236.6	6009.6	2.6
5VK2500	250.6	6365.2	2.8
5VK2650	265.6	6746.2	2.9
5VK2800	280.6	7127.2	3.1
5VK3000	300.6	7635.2	3.3
5VK3150	315.6	8016.2	3.5
5VK3350	335.6	8524.2	3.7
5VK3550	355.6	9032.2	3.9
8VK			
8VK2000	200.0	5080.0	6.1
8VK2360	236.0	5994.4	7.3
8VK2500	250.0	6350.0	7.7

Other sizes are available. Please contact customer service.

Aramax[®] Super Power-Wedge[®] Band Banded Belt

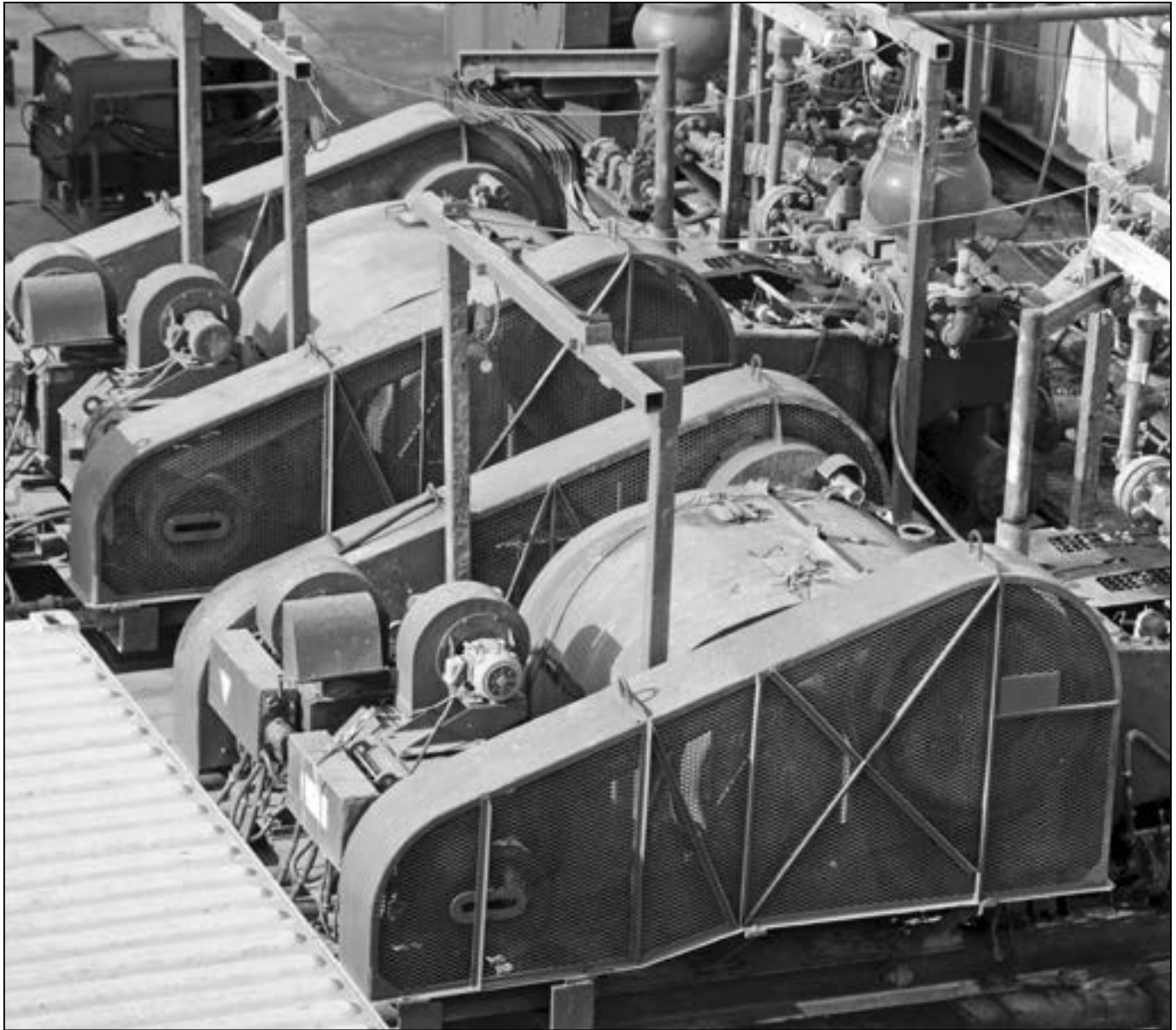

Aramax[®] Super Power-Wedge[®] Band

Banded Belt

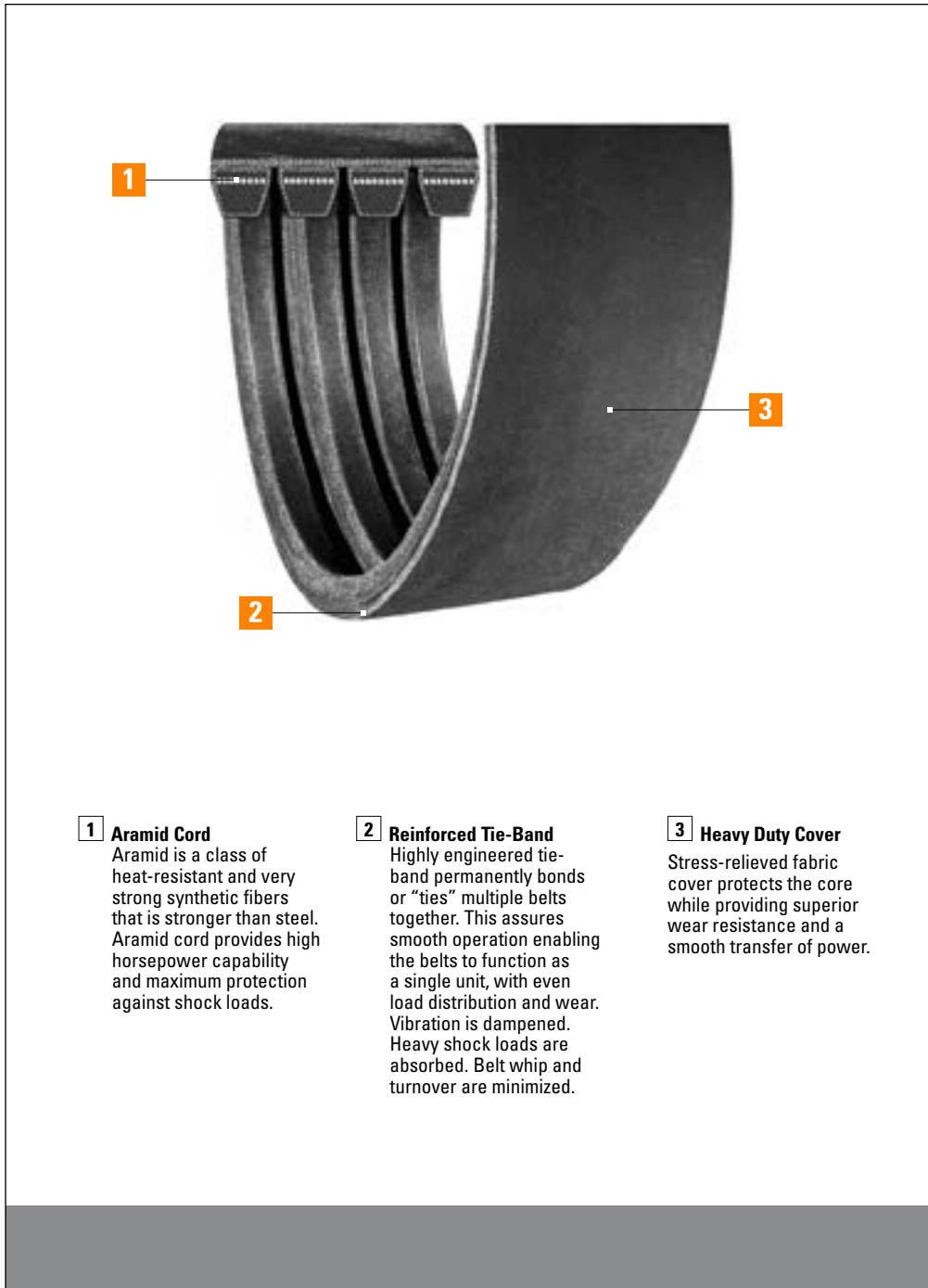

1 Aramid Cord
Aramid is a class of heat-resistant and very strong synthetic fibers that is stronger than steel. Aramid cord provides high horsepower capability and maximum protection against shock loads.

2 Reinforced Tie-Band
Highly engineered tie-band permanently bonds or “ties” multiple belts together. This assures smooth operation enabling the belts to function as a single unit, with even load distribution and wear. Vibration is dampened. Heavy shock loads are absorbed. Belt whip and turnover are minimized.

3 Heavy Duty Cover
Stress-relieved fabric cover protects the core while providing superior wear resistance and a smooth transfer of power.

Super high performance banded belt

Tough aramid cord construction

High horsepower capability

Maximum protection against shock loads

Highly engineered tie-band

Excels in harsh oil field and industrial applications

Applications:

- Oil field mud pumps
- Lumber industry drives
- Heavy construction machinery
- & More

Aramax[®] Super Power-Wedge[®] Band

Banded Belt

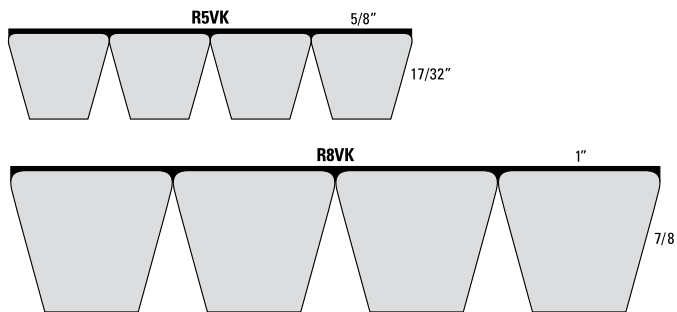

Aramax[®] Super Power-Wedge[®] Band belts are designed for extraordinary strength on the toughest drives.

Aramax[®] Super Power-Wedge[®] Band belts are ideally suited for oil field equipment, rock and quarry applications, forestry industry applications and heavy construction machinery. Aramid cord provides maximum protection against belt breakage due to shock loads.

The horsepower capacity per rib is significantly higher and provides substantial cost savings in belts and metal. Overhung load is also reduced and extends equipment service life when compared with 5V and 8V belts.

Because of the high horsepower loads involved, standard 5V and 8V cast iron Q-D[®] pulleys typically DO NOT have sufficient horsepower capacity to operate with the Aramax Super Power-Wedge Band at the belt's rated horsepower. As a result, special pulleys are frequently required as well.

Due to the unique nature of these "super high performance" banded belts, no drive design literature is available.

Use Drive Engineer to run an existing drive analysis. When designing a new drive, we suggest working with a Timken Belts application engineer.

Note: R5VK has a brown clutching cover and is not static dissipating. R8VK has a black cover and is static dissipating.

When these R5VK and R8VK belts are used as a matched set, all belts in the set must have the same sag number. These high modulus aramid cord belts require closer matching than standard R5V and R8V belts in order to tension properly as a set.

Maximum number of ribs available is 12.

Q-D[®] is a registered trademark of Regal Beloit America, Inc.

Aramax[®] Super Power-Wedge[®] Band Part Numbers

Part Number	Outside Circumference (inches)	Outside Circumference (mm)	Weight per Rib (lbs.)
R5VK Cross Section			
R5VK600	61.1	1552	1.6
R5VK630	64.1	1628	1.7
R5VK670	68.1	1730	1.8
R5VK710	72.1	1831	1.9
R5VK730	74.1	1882	1.9
R5VK750	76.1	1933	2.0
R5VK800	81.1	2060	11.5
R5VK850	86.1	2187	2.3
R5VK870	88.1	2238	2.3
R5VK900	91.1	2314	2.4
R5VK950	96.1	2441	2.5
R5VK1000	101.1	2568	2.6
R5VK1060	107.1	2720	2.8
R5VK1120	113.1	2873	2.9
R5VK1180	119.1	3025	3.1
R5VK1250	126.1	3203	3.3
R5VK1320	133.1	3381	3.5
R5VK1400	141.1	3584	15.3
R5VK1500	151.1	3838	6.2
R5VK1600	161.1	4092	4.2
R5VK1700	171.1	4346	4.4
R5VK1800	181.1	4600	4.7
R5VK1900	191.1	4854	5.0
R5VK2000	201.1	5108	12.9
R5VK2120	213.1	5413	5.5
R5VK2240	225.1	5718	5.9
R5VK2360	237.1	6022	6.2
R5VK2500	251.1	6378	6.5
R5VK2650	266.1	6759	7.3
R5VK2800	281.1	7140	7.3
R5VK3000	301.1	7648	7.8
R5VK3150	316.1	8029	8.2
R5VK3350	336.1	8537	8.8
R5VK3550	336.1	8537	18.4

Aramax[®] Super Power-Wedge[®] Band

Banded Belt

Part Number Example: **R8VK1500-4** =

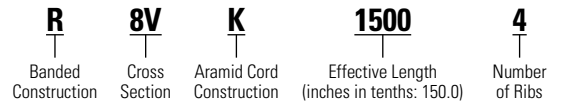

Part Number	Outside Circumference (inches)	Outside Circumference (mm)	Weight per Rib (lbs.)
R8VK Cross Section			
R8VK1500	151.5	3848	21.4
R8VK1600	161.5	4102	22.9
R8VK1700	171.5	4356	24.3
R8VK1800	181.5	4610	12.9
R8VK1900	191.5	4864	13.6
R8VK2000	201.5	5118	21.5
R8VK2120	213.5	5423	22.8
R8VK2160	217.5	5525	32.1
R8VK2240	225.5	5728	21.1
R8VK2360	237.5	6033	25.4
R8VK2500	251.5	6388	35.9
R8VK2600	261.5	6642	36.1
R8VK2650	266.5	6769	28.6
R8VK2780	279.5	7099	137.9
R8VK2800	281.5	7150	30.2
R8VK3000	301.5	7658	32.3
R8VK3150	316.5	8039	45.3
R8VK3350	336.5	8547	36.1
R8VK3550	356.5	9055	38.3
R8VK3750	376.5	9563	40.5
R8VK4000	401.1	10188	57.1
R8VK4250	426.1	10823	59.9
R8VK4500	451.1	11458	62.7
R8VK4750	476.1	12093	65.5
R8VK5000	501.1	12728	68.3
R8VK5600	561.1	14252	76.7



For complete part number, add the number of ribs required.

Metric Aramax® Super Power-Wedge®

V-Belt

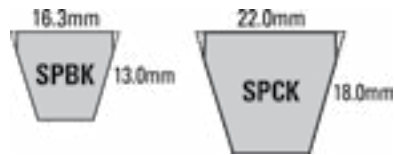

Part Number Example: **SPBK3000** = **SPB** **K** **3000**
Cross Section Aramid Cord Construction Pitch Length in millimeters

Metric Aramax® Super Power-Wedge® V-Belt Part Numbers

Part Number	Outside Circumference (inches)	Outside Circumference (mm)	Weight (lbs.)
SPBK Cross Section			
SPBK1900	75.4	1915.2	0.8
SPBK2500	99.5	2527.3	1.1
SPBK2650	105.1	2669.5	1.2
SPBK3000	119.0	3022.6	1.4
SPBK3150	125.0	3175.0	1.5
SPBK3350	132.5	3365.5	1.6
SPBK3550	140.5	3568.7	1.7
SPBK3750	148.6	3774.4	1.8
SPBK4000	158.5	4025.9	2.0
SPBK4250	168.3	4274.8	2.1
SPBK4500	178.2	4526.3	2.2
SPBK4750	188.0	4775.2	2.3
SPBK5000	198.4	5039.7	2.5
SPBK5300	222.9	5662.6	2.6
SPBK5600	249.8	6344.4	2.8
SPBK6000	283.0	7189.4	3.0
SPBK6300	317.0	8051.8	3.1
SPBK6700	358.0	9092.5	3.3
SPBK7100	401.7	10202.1	3.5
SPBK7500	447.6	11369.5	3.7
SPBK8000	503.9	12799.2	3.9

SPCK sizes are available. Please contact customer service.

Chipper Drive Wedge-Band® Banded Belt

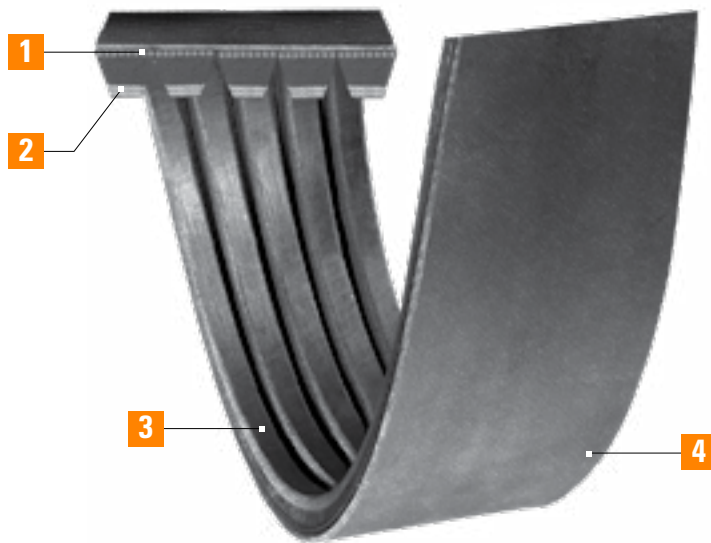

1 Oversized Polyester Cord

High-modulus cord carries the horsepower load with minimum stretch. Specially treated to produce a long-lasting bond with the surrounding rubber assuring longer belt life. Adds belt strength and stability during peak shock loads.

2 Multiple Plies of Laminated Fabric and Rubber

Multiple plies of rubber and fabric are bonded together in the compression section of the belt. While the raw edge laminated construction provides drive efficiency, the plies of the lower section reduce belt aggressiveness – a combination that provides the key to controlled slippage under peak loads.

3 EPDM

(Ethylene Propylene Diene Monomer) is static conductive, durable, and resistant to heat, hardening, and glazing.

4 Reinforced Tie-Band

Highly engineered tie-band permanently bonds multiple belts together. This assures smooth operation enabling the belts to function as a single unit, with even load-distribution and wear. The tie-band helps prevent wood chips from lodging in the drive. Vibration is dampened. Heavy shock loads are absorbed. Belt whip and turnover are minimized.

Recommended Pulleys:

Hi-Cap Wedge – QD, Taper Bushed, or MST (5V)

Laminated banded belt built tough for forestry applications

Oversized polyester cord provides added belt strength and stability

EPDM has a broad operating temperature range (-50° to +250°F)

Multiple layers of fabric provide controlled slippage under peak loads

Long belt life

Durable

Oil and heat resistant

Static conductive

Resists hardening and glazing

Minimizes belt whip and rollover

Vibration is dampened

Heavy shock loads are absorbed

Applications:

- Chipper saws
- De-barker drives
- Head rigs
- Hogs
- & More

Chipper Drive Wedge-Band®

Banded Belt

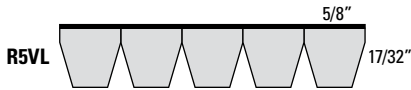

Part Number Example: **R5VL1000-5** =

R Banded Construction
5V Cross Section
L Non-Cogged Construction
1000 Effective Length (inches in tenths: 100.0)
5 Number of Ribs

Chipper Drive Wedge-Band® belts are specially designed and constructed to meet the unique demands of the forestry products industry

The laminated belt is made of Ethylene Propylene Diene Monomer (EPDM), a synthetic rubber that is durable, heat resistant, static conductive and resistant to hardening and glazing. EPDM offers superior flex and load carrying capacity and a broad operating temperature range of -50°F to +250°F.

Instead of using sets of individual belts, this banded belt is engineered with a special raw edge laminated construction that provides perfect balance between the controlled transfer of power and slippage.

It is designed to slip during “overload” or drive stall conditions. By allowing the belt to have controlled slippage less heat is generated, which results in longer belt life.

The tie-band is highly engineered to permanently bond multiple belts together enabling the belts to function as a single unit with even load distribution and wear. The banded belt construction minimizes belt whip and rollover.

For complete part number, add the number of ribs required. For example: R5VL1000-5



Chipper Drive Wedge-Band® Part Numbers

Part Number	Top Width (inches)	Thickness (inches)	Outside Circumference (inches)	Outside Circumference (mm)	Weight per Rib (lbs.)
5VL – Banded Section Recommended Pulleys: Hi-Cap Wedge – OD, Taper Bushed, or MST (5V)					
R5VL800	5/8"	17/32"	81.1	2060	5.7
R5VL850	5/8"	17/32"	86.1	2187	6.0
R5VL900	5/8"	17/32"	91.1	2314	2.6
R5VL950	5/8"	17/32"	96.1	2441	6.7
R5VL1000	5/8"	17/32"	101.1	2568	4.3
R5VL1060	5/8"	17/32"	107.1	2720	107.1
R5VL1120	5/8"	17/32"	113.1	2873	7.9
R5VL1180	5/8"	17/32"	119.1	3025	119.1
R5VL1320	5/8"	17/32"	133.1	3381	5.6
R5VL1320	5/8"	17/32"	133.1	3381	9.4
R5VL1700	5/8"	17/32"	171.1	4346	12.1

Gold-Ribbon® Cog-Belt®

V-Belt

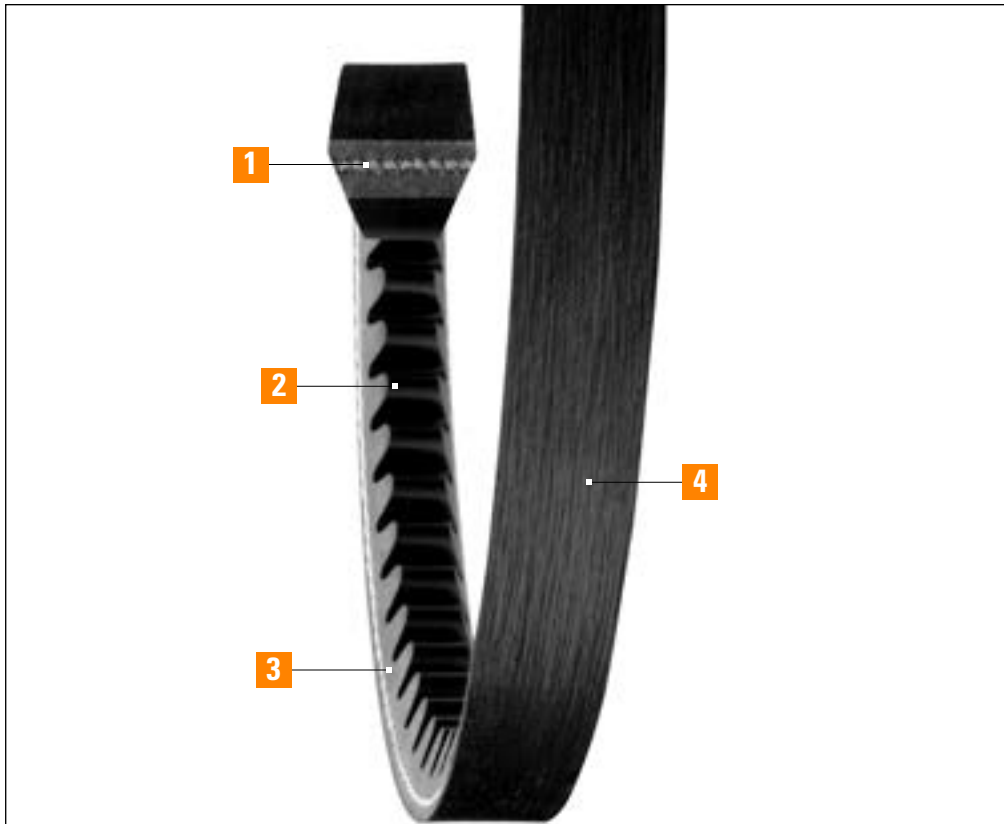

1 Oversized Polyester Cord
High-modulus cord carries the horsepower load with minimum stretch. Specially treated to produce a long-lasting bond with the surrounding rubber assuring longer belt life. Adds belt strength and stability during peak shock loads.

2 Precision Molded Cogs
Improves flexibility and reduces stress that enables the belt to bend more easily around the pulley. It runs cooler – less heat equals longer belt life. Smaller pulley diameters mean lower cost and space savings.

3 Raw Edge Sidewalls
Produces a higher coefficient of friction and minimizes slippage. The gripping power provides higher energy efficiency and reduces vibration for extended component life. The raw edge construction also allows more cord width for increased horsepower capacity.

4 EPDM Construction
Offers superior flex and load carrying capacity at high and low temperatures. EPDM is durable, static conductive and resistant to heat, hardening and glazing.

Recommended Sheaves:
Conventional – OD, Taper Bushed, or MST (A-B, C, D)

The energy saver

High performance
EPDM construction:

Broader temperature
operating range
(-50° – +250°)

50% longer life

30% higher horsepower

Static conductive

Greater design flexibility

chekmate®

Applications:

Blowers
Pumps
HVAC
High ambient temperature
exhaust fans
& More

Gold-Ribbon® Cog-Belt®

V-Belt

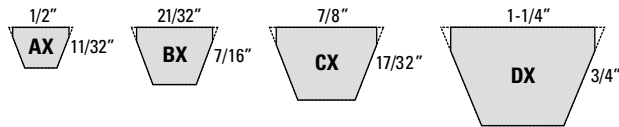

The gold standard! Gold-Ribbon® Cog-Belt® sets the benchmark for classical v-belt performance. Reduce downtime and save energy with increased power ratings and longer belt life than wrapped v-belts.

The Energy Saver! Unique Gold-Ribbon® Cog-Belt® construction combines the superior flexing capability of precision molded cogs with the tenacious gripping power of raw-edge sidewalls to provide significantly longer belt life, higher efficiency, and greater horsepower ratings than conventional wrapped belts

Made with Ethylene Propylene Diene Monomer (EPDM), a synthetic rubber with outstanding properties, the Gold-Ribbon® Cog-Belt® is static conductive durable, and resistant to heat, hardening, and glazing. Ordinary wrapped belts waste energy, time, and money. The Gold-Ribbon Cog-Belt has been engineered to take advantage of countless developments in materials and technology.

More reasons to switch to the Gold-Ribbon Cog-Belt:

- Specially formulated EPDM withstands heat, dirt, grease, chemicals and environmental conditions
- Design flexibility – Gold-Ribbon Cog-Belts transmit up to 30% more horsepower than conventional belts utilizing the same drive space – or pack the same horsepower into a space one-half to two-thirds the size
- No excessive heat build-up or wear problems even under adverse operating conditions such as reverse bends, backside idlers and constant starts and stops
- Save space with narrower sheaves
- Reduced weight and overhang decreases bearing loads
- Broad operating temperature (-50° to +250°F)
- Belt sidewalls reduce vibration for extended component life
- Cog profile reduces bending stress
- Built to Chek Mate belt tolerances for a matched set

Performance and savings in one package.

The Gold-Ribbon Cog-Belt gets the job done anywhere there are space, weight or pulley limitations– or where increased horsepower capacity and/or higher speeds are necessary. Using smaller pulleys, the Gold-Ribbon Cog-Belt provides a higher horsepower rating than conventional wrapped v-belts. This enables the design of a more efficient, more compact, and ultimately more profitable drives.

Horsepower Rating Comparison

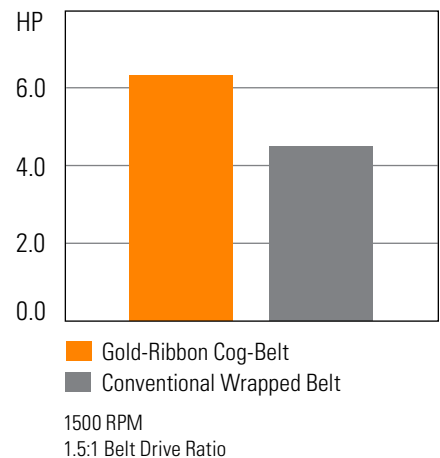

Gold-Ribbon® Cog-Belt®

V-Belt

Gold-Ribbon® Cog-Belt® Part Numbers

Part Number Example: **AX50** = **A** **X** **50**
↓ ↓ ↓
Cross Cogged Inside
Section Construction Circumference
(inches)

Part Number	Outside Circumference (inches)	Outside Circumference (mm)	Weight (lbs.)
AX Section – Recommended Sheaves: Conventional – QD, Taper Bushed, or MST (A-B)			
AX20	22.5	572	0.1
AX21	23.4	594	0.1
AX22	24.5	622	0.1
AX23	25.3	643	0.1
AX24	26.6	676	0.1
AX25	27.5	699	0.2
AX26	28.4	721	0.2
AX27	29.4	747	0.2
AX28	30.3	770	0.2
AX29	31.6	803	0.2
AX30	32.5	826	0.2
AX31	33.5	851	0.2
AX32	34.4	874	0.2
AX33	35.3	897	0.2
AX34	36.6	930	0.2
AX35	37.5	953	0.2
AX36	38.3	973	0.2
AX37	39.4	1001	0.2
AX38	40.2	1021	0.2
AX39	41.3	1049	0.2
AX40	42.4	1077	0.2
AX41	43.5	1105	0.2
AX42	44.4	1128	0.2
AX43	45.4	1153	0.3
AX44	46.2	1174	0.3
AX45	47.5	1207	0.3
AX46	48.5	1232	0.3
AX47	49.3	1252	0.3
AX48	50.2	1275	0.2
AX49	51.2	1301	0.2
AX50	52.4	1331	0.3
AX51	53.4	1356	0.3
AX52	54.4	1382	0.3
AX53	55.3	1405	0.3

Part Number	Outside Circumference (inches)	Outside Circumference (mm)	Weight (lbs.)
AX Section – Recommended Sheaves: Conventional – QD, Taper Bushed, or MST (A-B)			
AX54	56.2	1428	0.3
AX55	57.4	1458	0.3
AX56	58.3	1481	0.3
AX57	59.3	1506	0.3
AX58	60.5	1537	0.4
AX59	61.4	1560	0.4
AX60	62.6	1590	0.3
AX61	63.6	1615	0.4
AX62	64.5	1638	0.4
AX63	65.4	1661	0.4
AX64	66.4	1687	0.4
AX65	67.3	1709	0.4
AX66	68.6	1742	0.3
AX67	69.5	1765	0.4
AX68	70.4	1788	0.3
AX69	71.4	1814	0.4
AX70	72.3	1836	0.4
AX71	73.6	1869	0.4
AX72	74.5	1892	0.3
AX73	75.5	1918	0.4
AX74	76.4	1941	0.4
AX75	77.3	1963	0.4
AX76	78.6	1996	0.5
AX77	79.5	2019	0.5
AX78	80.5	2045	0.5
AX79	81.4	2068	0.5
AX80	82.4	2093	0.5
AX81	83.1	2111	0.4
AX82	84.3	2141	0.4
AX83	85.2	2164	0.4
AX84	86.4	2195	0.4
AX85	87.4	2220	0.5
AX86	88.3	2243	0.5
AX87	89.6	2276	0.4

Gold-Ribbon® Cog-Belt®

V-Belt

Gold-Ribbon® Cog-Belt® Part Numbers

Part Number	Outside Circumference (inches)	Outside Circumference (mm)	Weight (lbs.)
AX Section – Recommended Sheaves: Conventional – QD, Taper Bushed, or MST (A-B)			
AX88	90.5	2299	0.5
AX89	91.4	2322	0.4
AX90	92.1	2339	0.4
AX91	93.3	2370	0.5
AX92	94.4	2398	0.4
AX93	95.5	2426	0.4
AX94	96.4	2449	0.4
AX95	97.4	2474	0.4
AX96	98.3	2497	0.6
AX97	99.6	2530	0.6
AX98	100.3	2548	0.5
AX99	101.3	2573	0.6
AX100	102.4	2601	0.5
AX103	105.5	2680	0.6
AX105	107.4	2728	0.6
AX110	112.4	2855	0.6
AX112	114.6	2911	0.6
AX120	122.4	3109	0.6
AX128	130.4	3312	0.6
AX136	138.4	3515	0.6
AX144	146.4	3719	0.7
AX158	160.4	4074	0.7
AX173	175.4	4455	0.8
AX180	182.4	4633	0.8
BX Section – Recommended Sheaves: Conventional – QD, Taper Bushed, or MST (A-B)			
BX23	26.4	671	0.2
BX240	242.4	6157	2.5
BX255	257.4	6538	3.1
BX26	29.2	742	0.3
BX27	30.1	765	0.3
BX270	272.4	6919	3.1
BX28	31.4	798	0.3

Part Number	Outside Circumference (inches)	Outside Circumference (mm)	Weight (lbs.)
BX Section – Recommended Sheaves: Conventional – QD, Taper Bushed, or MST (A-B)			
BX29	32.3	820	0.2
BX30	33.3	846	0.3
BX300	302.4	7681	3.1
BX31	34.2	869	0.3
BX32	35.2	894	0.3
BX33	36.3	922	0.3
BX34	37.4	950	0.3
BX35	38.3	973	0.3
BX36	39.2	996	0.3
BX37	40.2	1021	0.4
BX38	41.4	1052	0.4
BX39	42.4	1077	0.3
BX40	43.3	1100	0.4
BX41	44.3	1125	0.3
BX42	45.2	1148	0.4
BX43	46.1	1171	0.4
BX44	47.4	1204	0.4
BX45	48.3	1227	0.4
BX46	49.2	1250	0.4
BX47	50.2	1275	0.5
BX48	51.2	1301	0.5
BX49	52.2	1326	0.5
BX50	53.4	1356	0.5
BX51	54.3	1379	0.5
BX52	55.3	1405	0.5
BX53	56.1	1425	0.5
BX54	57.1	1450	0.5
BX55	58.4	1483	0.5
BX56	59.3	1506	0.5
BX57	60.3	1532	0.6
BX58	61.2	1555	0.5
BX59	62.2	1580	0.6
BX60	63.4	1610	0.5

Gold-Ribbon® Cog-Belt®

V-Belt

Gold-Ribbon® Cog-Belt® Part Numbers

Part Number Example: **CX120** =

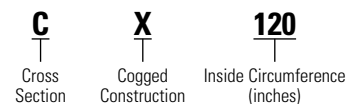

Part Number	Outside Circumference (inches)	Outside Circumference (mm)	Weight (lbs.)
BX Section – Recommended Sheaves: Conventional – QD, Taper Bushed, or MST (A-B)			
BX162	165.3	4199	1.3
BX169	172.3	4376	1.3
BX173	176.3	4478	1.4
BX180	183.3	4656	1.4
BX191	194.3	4935	1.5
BX195	198.3	5037	1.5
BX205	208.9	5306	1.8
BX210	213.9	5433	2.2
BX225	227.4	5776	2.4
CX Section – Recommended Sheaves: Conventional – QD, Taper Bushed, or MST (C)			
CX47	51.6	1311	0.7
CX49	53.6	1361	0.7
CX51	55.6	1412	0.8
CX52	56.6	1438	0.8
CX55	59.6	1514	0.8
CX60	64.6	1641	0.9
CX61	65.6	1666	0.9
CX62	66.6	1692	0.9
CX65	69.6	1768	0.9
CX66	70.6	1793	1.0
CX68	72.6	1844	1.0
CX71	75.6	1920	1.0
CX72	76.6	1946	1.1
CX75	79.6	2022	1.1
CX78	82.6	2098	1.1
CX79	83.6	2123	1.1
CX81	85.6	2174	1.2
CX85	89.6	2276	1.2
CX90	94.6	2403	1.3
CX96	100.6	2555	1.4
CX98	102.6	2606	1.4
CX100	104.6	2657	1.5

Part Number	Outside Circumference (inches)	Outside Circumference (mm)	Weight (lbs.)
CX Section – Recommended Sheaves: Conventional – QD, Taper Bushed, or MST (C)			
CX101	105.6	2682	1.5
CX103	107.6	2733	1.5
CX105	109.6	2784	1.5
CX106	110.6	2809	1.5
CX109	113.6	2885	1.6
CX111	115.6	2936	1.6
CX112	116.6	2962	1.6
CX114	118.6	3012	1.6
CX115	119.6	3038	1.7
CX120	124.6	3165	1.7
CX124	128.6	3266	1.8
CX128	132.6	3368	1.8
CX133	137.6	3495	1.9
CX136	140.6	3571	1.9
CX144	148.6	3774	2.1
CX148	152.6	3876	2.1
CX150	154.6	3927	2.1
CX158	162.6	4130	2.3
CX162	166.6	4232	2.3
CX173	177.6	4511	2.5
CX180	184.6	4689	2.6
CX187	191.6	4867	2.6
CX190	194.6	4943	2.6
CX195	199.6	5070	2.8
CX210	215.1	5464	3.3
CX225	228.1	5794	3.8
CX240	243.1	6175	4.1
CX255	258.1	6556	4.5
CX270	273.1	6937	3.9
CX300	303.1	7699	5.0
CX330	333.1	8461	5.4

Gold-Ribbon® Cog-Belt®

V-Belt

Part Number Example: **DX270** = **D** **X** **270**
Cross Section Cogged Construction Inside Circumference (inches)

Part Number	Outside Circumference (inches)	Outside Circumference (mm)	Weight (lbs.)
DX Section – Recommended Sheaves: Conventional – QD, Taper Bushed, or MST (D)			
DX71	76.3	1938	2.2
DX100	105.5	2680	3.0
DX120	125.5	3188	4.3
DX128	133.5	3391	3.7
DX144	149.5	3797	4.2
DX158	163.5	4153	4.6
DX162	167.5	4255	4.7
DX173	178.5	4534	5.0
DX180	185.5	4712	5.2
DX195	200.5	5093	5.6
DX210	216.1	5489	7.2
DX225	228.6	5806	7.7
DX240	243.6	6187	8.2
DX255	258.6	6568	7.5
DX270	273.6	6949	9.6
DX300	303.6	7711	9.5
DX330	333.6	8473	10.9



Synchronous Belts

V-Belts

Specialty Belts

Tools

General Information

Gold-Ribbon® Cog-Band®

Banded Belt

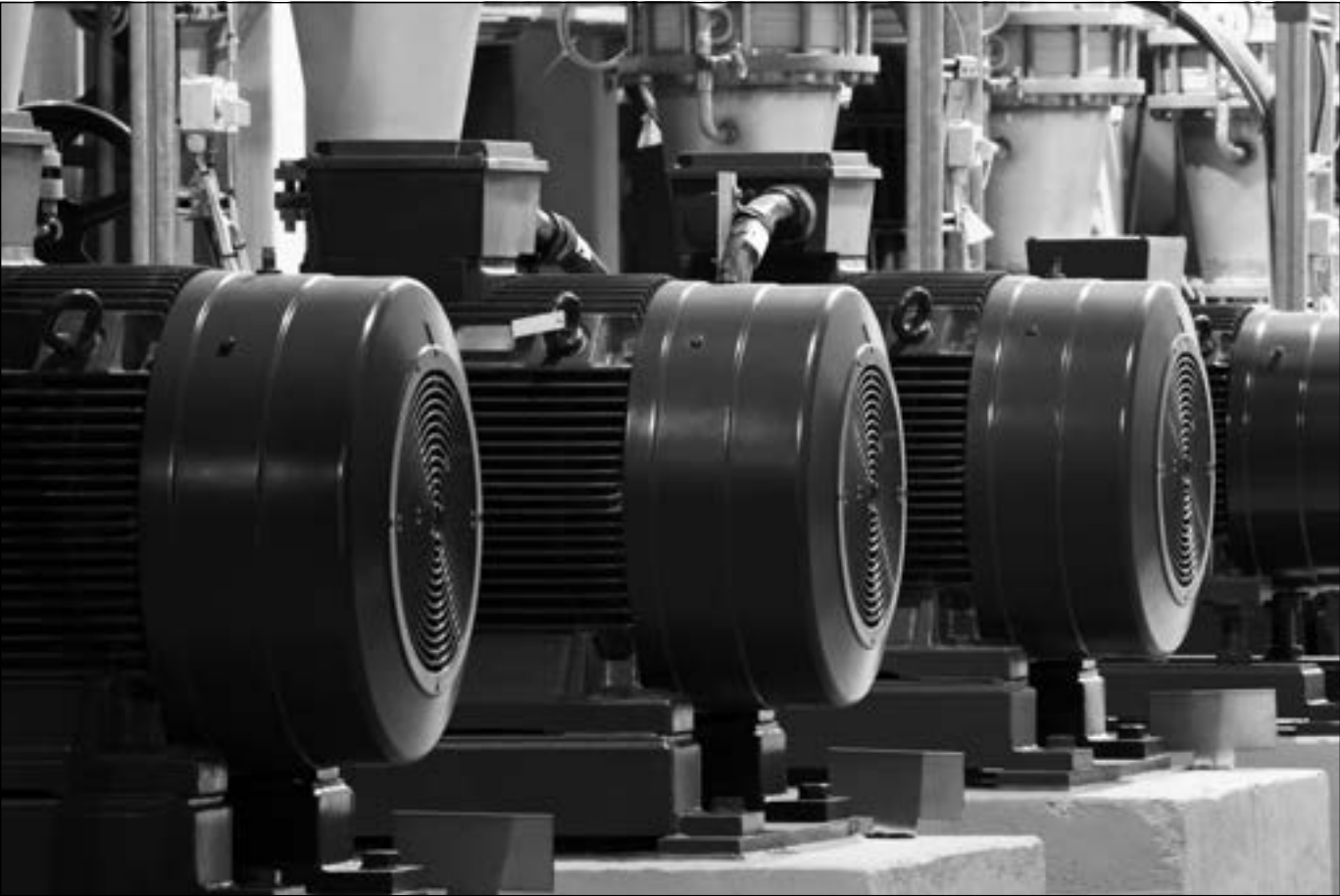

Gold-Ribbon® Cog-Band® Banded Belt



1 Oversized Polyester Cord
High-modulus cord carries the horsepower load with minimum stretch. Specially treated to produce a long-lasting bond with the surrounding rubber assuring longer belt life. Adds belt strength and stability during peak shock loads.

2 Precision Molded Cogs
Superior flexibility with reduced bending stress helps dissipate heat providing significantly longer belt life. Allows use of smaller pulley diameters. A cost and space saver.

3 Raw Edge Sidewalls
Produces a higher coefficient of friction and minimizes slippage. The gripping power provides higher energy efficiency and reduces vibration for extended component life.

4 EPDM
Ethylene Propylene Diene Monomer (EPDM) is a synthetic rubber that is durable and resistant to heat, oil, hardening and glazing. EPDM has superior flex and load carrying capacity with a broad operating temperature range of -50°F to +250°F.

5 Reinforced Tie-Band
Highly engineered tie-band permanently bonds or “ties” multiple belts together. This assures smooth operation enabling the belts to function as a single unit, with even load distribution and wear. Vibration is dampened. Heavy shock loads are absorbed. Belt whip and turnover are minimized.

Recommended Pulleys:
Conventional – OD, Taper Bushed, or MST (A-B, C, D)

Banded version of
Gold-Ribbon Cog-Belt

Minimizes belt
whip and turnover

EPDM raw edge
construction

Long belt life

High horsepower

Static dissipating

Applications:

- Blowers
- Fans
- Pumps
- & More

Synchronous Belts

V- Belts

Specialty Belts

Tools

General Information

Gold-Ribbon® Cog-Band®

Banded Belt

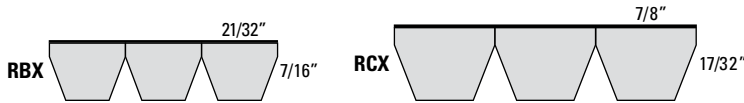

Two or more Gold-Ribbon Cog-Belts are permanently joined together at the top with a reinforced tie-band. Ideally suited for pulsating or heavily shock loaded drives and drives with long center distances to minimize belt whip and rollover.

This banded version of “The Energy Saver” combines the longer life and superior performance of the Gold-Ribbon® Cog-Belt® with the stability of a banded belt.

The unique construction features Ethylene Propylene Diene Monomer (EPDM), with the superior flexing of precision molded cogs and the tenacious gripping power of raw edge sidewalls to provide significantly longer belt life, improved efficiency and higher horsepower ratings.

EPDM is static conductive, durable, and resistant to heat, hardening, and glazing.

Banded belts assure that each rib is sharing the load equally to achieve the full horsepower capacity of the drive. The reinforced band across the top greatly enhances stability by minimizing belt whip and turnover.

For complete part number, add the number of ribs required For example: RBX100-3.



Product Type and Length Code	Match Limit
Gold-Ribbon® Cog-Band®	
RBX51 – RBX61	1
RBX62 – RBX144	2
RBX158 and longer	3
RCX68 – RCX144	2
RCX158 and longer	3
RDX120 – RDX144	2
RDX158 and longer	3

Horsepower Rating Comparison

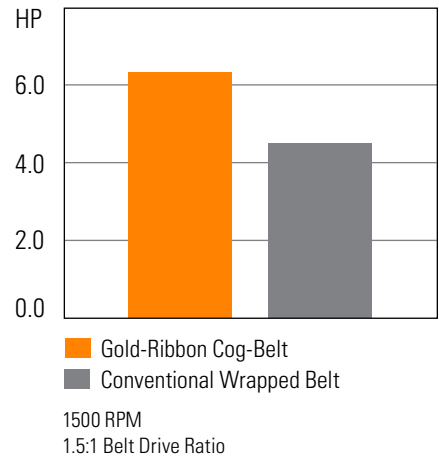

Energy Efficiency Comparison

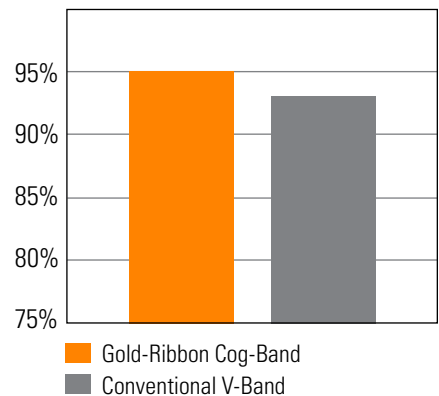

Gold-Ribbon® Cog-Band® Banded Belts

Gold-Ribbon® Cog-Band® Part Numbers

Part Number	Outside Circumference (inches)	Outside Circumference (mm)	Weight per Rib (lbs.)
RBX – Banded BX Section; Recommended Pulleys: Conventional – QD, Taper Bushed, or MST (A-B)			
RBX37	41	1041	0.9
RBX51	55	1397	1.3
RBX53	57	1448	1.3
RBX55	59	1499	1.4
RBX56	60	1524	1.4
RBX58	62	1575	1.4
RBX59	63	1600	1.4
RBX60	64	1626	1.5
RBX61	65	1651	1.5
RBX62	66	1676	1.5
RBX63	67	1702	1.5
RBX64	68	1727	1.6
RBX65	69	1753	1.6
RBX66	70	1778	1.6
RBX67	71	1803	1.6
RBX68	72	1829	1.7
RBX70	74	1880	1.7
RBX71	75	1905	1.7
RBX73	77	1956	1.8
RBX75	79	2007	1.8
RBX77	81	2057	1.9
RBX78	82	2083	1.9
RBX79	83	2108	1.9
RBX80	84	2134	2.0
RBX81	85	2159	2.0
RBX83	87	2210	2.0
RBX85	89	2261	2.1
RBX90	94	2388	2.2
RBX93	97	2464	2.3
RBX95	99	2515	2.3
RBX97	101	2565	2.4
RBX100	104	2642	2.4

Part Number Example: **RBX100 =**

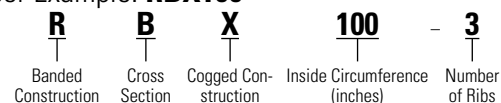

Part Number	Outside Circumference (inches)	Outside Circumference (mm)	Weight per Rib (lbs.)
RBX – Banded BX Section; Recommended Pulleys: Conventional – QD, Taper Bushed, or MST (A-B)			
RBX102	106	2692	2.5
RBX103	107	2718	2.5
RBX105	109	2769	2.6
RBX108	112	2845	2.6
RBX110	114	2896	4.0
RBX112	116	2946	2.7
RBX116	120	3048	2.8
RBX120	124	3150	2.9
RBX128	132	3353	3.1
RBX136	140	3556	3.3
RBX144	148	3759	3.5
RBX158	161.3	4097	3.8
RBX160	163.3	4148	3.9
RBX173	176.3	4478	4.2
RBX180	183.3	4656	4.4
RBX195	198.3	5037	4.7
RCX – Banded CX Section Recommended Pulleys: Conventional – QD, Taper Bushed, or MST (C)			
RCX68	73.3	1862	2.8
RCX75	80.3	2040	3.0
RCX78	83.3	2116	3.1
RCX81	86.3	2192	3.3
RCX85	90.3	2294	3.4
RCX90	94.9	2411	3.6
RCX96	100.9	2563	3.8
RCX105	109.9	2792	4.2
RCX112	116.9	2969	4.5
RCX120	124.9	3173	4.8
RCX128	132.9	3376	5.1
RCX131	135.9	3452	5.2
RCX136	140.9	3579	5.4
RCX137	141.9	3604	5.5

Gold-Ribbon® Cog-Band®

Banded Belts

Gold-Ribbon® Cog-Band® Part Numbers

Part Number	Outside Circumference (inches)	Outside Circumference (mm)	Weight per Rib (lbs.)
RCX – Banded CX Section Recommended Pulleys: Conventional – OD, Taper Bushed, or MST (C)			
RCX144	148.9	3782	5.7
RCX158	162.9	4138	6.3
RCX162	166.9	4239	6.5
RCX173	177.9	4519	6.9
RCX180	184.9	4697	7.2
RCX190	194.9	4951	7.6
RCX195	199.9	5078	7.8

Part Number Example: **RCX190-3 =**

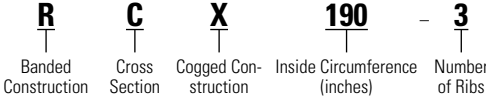



1 Oversized Polyester Cord
High-modulus cord located in the belt mid-section is specially treated to withstand extreme belt loads and shock without stretching. The central position contributes to greater flexibility and stability.

2 Premium Fabric
Multiple fabric plies, top and bottom, relieve stress on the load-carrying center cord for added flexibility.

3 Raw Edge Sidewalls
Produces a higher coefficient of friction and minimizes slippage. The gripping power provides higher energy efficiency and reduces vibration for extended component life.

4 EPDM Construction
Offers superior flex and load carrying capacity at high and low temperatures. EPDM is durable, static conductive and resistant to heat, hardening and glazing.

Recommended Sheaves:
Conventional – OD, Taper Bushed, or MST (A-B, C)

The “Problem Solver”

For classical v-belt applications

Unique CNA design

Flexible

Stable

Static conductive

Energy efficient

Resistant to hardening and glazing

Broad operating temperature range

chekmate®

Applications:

Shaker screens

Debarkers

HVAC

Industrial washers and
dryers

& More

Super II® V-Belt

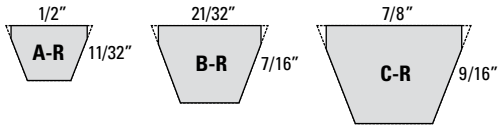

The Problem Solver! Super II v-belts are the solution to the constant and costly problem of replacing ordinary v-belts on troublesome drives.

Classical laminated raw edge v-belt made of Ethylene Propylene Diene Monomer (EPDM) with Central Neutral Axis (CNA) cord placement that creates a flexible, stable and efficient v-belt.

Specially formulated fiber-loaded EPDM rubber compounds, engineered fabrics and high-modulus polyester cord offer greater strength, longer life, better heat dissipation and higher efficiencies than best-in-class wrapped v-belts.

EPDM is durable, heat resistant, static conductive and resistant to hardening and glazing. The unique CNA (central neutral axis) cord placement positions the strength of the belt lower on the pulleys to maintain stability and prevent roll-over. The raw edge construction results in more efficient power transmission and reduced energy loss.

Multiple fabric plies, top and bottom, relieve stress on the load-carrying center cord for added flexibility. The quantity of fabric plies varies per cross section, with an equal number of plies above and below the cord.



Look what the Super II® v-belt has to offer:

- High performance alternative to wrapped v-belts
- Unique design for long belt life
- Grip with controlled slippage
- Low maintenance and downtime
- More energy efficient than wrapped v-belts
- Static conductive
- Resistant to hardening and glazing
- Broad operating temperature range (-50°F to +250°F)

Don't take our word for it! Compare Super II to the belt you are now using on your heavy torque, high horsepower and extreme shock-load applications.

Tensile Strength

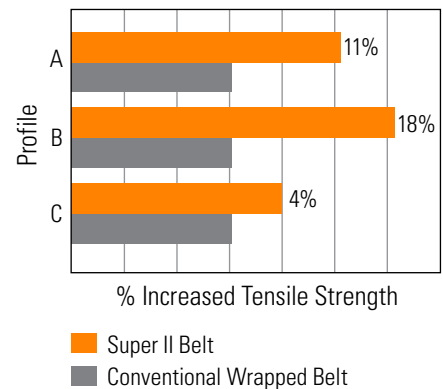

Accelerated Life Test (Laboratory)

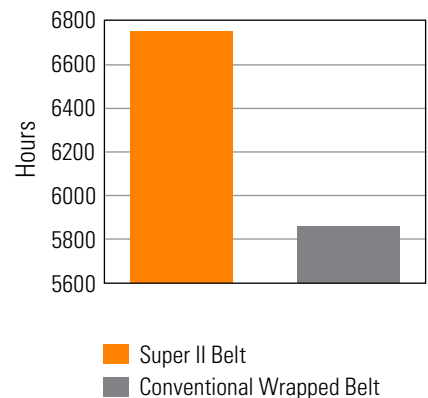

Super II® V-Belt Part Numbers

Part Number Example: **A50R** =

A
↓
Cross Section

50
↓
Inside Circumference (inches)

R
↓
Raw Edge Construction

Part Number	Outside Circumference (inches)	Outside Circumference (mm)	Weight (lbs.)
A-R Section – Recommended Sheaves: Conventional – QD, Taper Bushed, or MST (A-B)			
A21R	23.2	589	0.2
A22R	24.1	612	0.2
A23R	25.3	643	0.2
A24R	26.3	668	0.2
A25R	27.2	691	0.2
A26R	28.2	716	0.2
A27R	29.1	739	0.2
A28R	30.4	772	0.2
A29R	31.3	795	0.2
A30R	32.2	818	0.2
A31R	33.2	843	0.2
A32R	34.4	874	0.2
A33R	35.4	899	0.2
A34R	36.3	922	0.2
A35R	37.3	947	0.2
A36R	38.2	970	0.3
A37R	39.3	998	0.3
A38R	40.5	1029	0.3
A39R	41.3	1049	0.3
A40R	42.3	1074	0.3
A41R	43.2	1097	0.3
A42R	44.3	1125	0.3
A43R	45.4	1153	0.3
A44R	46.4	1179	0.3
A45R	47.3	1201	0.3
A46R	48.2	1224	0.3
A47R	49.2	1250	0.3
A48R	50.5	1283	0.3
A49R	51.4	1306	0.3
A50R	52.3	1328	0.3
A51R	53.3	1354	0.4
A52R	54.2	1377	0.4
A53R	55.4	1407	0.4

Part Number	Outside Circumference (inches)	Outside Circumference (mm)	Weight (lbs.)
A-R Section – Recommended Sheaves: Conventional – QD, Taper Bushed, or MST (A-B)			
A54R	56.4	1433	0.4
A55R	57.3	1455	0.4
A56R	58.2	1478	0.4
A57R	59.2	1504	0.4
A58R	60.4	1534	0.4
A59R	61.4	1560	0.4
A60R	62.3	1582	0.4
A61R	63.3	1608	0.4
A62R	64.2	1631	0.4
A63R	65.2	1656	0.4
A64R	66.5	1689	0.4
A65R	67.3	1709	0.5
A66R	68.3	1735	0.5
A67R	69.2	1758	0.5
A68R	70.5	1791	0.5
A69R	71.4	1814	0.5
A70R	72.4	1839	0.5
A71R	73.3	1862	0.5
A72R	74.2	1885	0.5
A73R	75.4	1915	0.5
A74R	76.4	1941	0.5
A75R	77.1	1958	0.5
A76R	78.3	1989	0.5
A77R	79.2	2012	0.5
A78R	80.1	2035	0.5
A79R	81.5	2070	0.5
A80R	82.3	2090	0.5
A81R	83.3	2116	0.6
A82R	84.3	2141	0.6
A83R	85.1	2162	0.6
A84R	86.4	2195	0.6
A85R	87.4	2220	0.6
A86R	88.3	2243	0.6

Super II® V-Belt

Super II® V-Belt Part Numbers

Part Number	Outside Circumference (inches)	Outside Circumference (mm)	Weight (lbs.)
A-R Section – Recommended Sheaves: Conventional – QD, Taper Bushed, or MST (A-B)			
A87R	89.3	2268	0.6
A88R	90.2	2291	0.6
A89R	91.4	2322	0.6
A90R	92	2337	0.6
A91R	93.4	2372	0.6
A92R	94.3	2395	0.6
A93R	95.3	2421	0.6
A94R	96.4	2449	0.6
A95R	97.4	2474	0.7
A96R	98.4	2499	0.7
A97R	99.2	2520	0.7
A98R	100.2	2545	0.7
A100R	102.4	2601	0.7
A103R	105.2	2672	0.7
A105R	107.2	2723	0.7
A110R	112.1	2847	0.8
A112R	114.2	2901	0.8
A120R	122.2	3104	0.8
A128R	130.2	3307	0.9
A136R	138.2	3510	0.9
A144R	146.2	3714	1.0
A158R	160.2	4069	1.1
A173R	175.2	4450	1.2
A180R	182.2	4628	1.2
B-R Section – Recommended Sheaves: Conventional – QD, Taper Bushed, or MST (A-B)			
B24R	27.3	693	0.3
B26R	28.9	734	0.3
B27R	30.1	765	0.3
B28R	31	787	0.3
B29R	32	813	0.3
B30R	33.3	846	0.3

Part Number	Outside Circumference (inches)	Outside Circumference (mm)	Weight (lbs.)
B-R Section – Recommended Sheaves: Conventional – QD, Taper Bushed, or MST (A-B)			
B31R	34.2	869	0.4
B32R	35.2	894	0.4
B33R	36.1	917	0.4
B34R	37	940	0.4
B35R	38.1	968	0.4
B36R	39.1	993	0.4
B37R	40.2	1021	0.4
B38R	41.1	1044	0.4
B39R	42.1	1069	0.4
B40R	43	1092	0.5
B41R	43.9	1115	0.5
B42R	45.2	1148	0.5
B43R	46.1	1171	0.5
B44R	47.1	1196	0.5
B45R	48	1219	0.5
B46R	49	1245	0.5
B47R	50.2	1275	0.5
B48R	51.2	1301	0.5
B49R	52.1	1323	0.5
B50R	53	1346	0.6
B51R	54.1	1374	0.6
B52R	54.9	1395	0.6
B53R	56.2	1428	0.6
B54R	57.1	1450	0.6
B55R	58.1	1476	0.6
B56R	59	1499	0.6
B57R	60	1524	0.6
B58R	60.9	1547	0.6
B59R	62.2	1580	0.7
B60R	63.1	1603	0.7
B61R	64	1626	0.7
B62R	65	1651	0.7

Part Number Example: **B70R** = **B** **70** **R**
Cross Section Inside Circumference (inches) Raw Edge Construction

Part Number	Outside Circumference (inches)	Outside Circumference (mm)	Weight (lbs.)
B-R Section – Recommended Sheaves: Conventional – QD, Taper Bushed, or MST (A-B)			
B63R	65.9	1674	0.7
B64R	67.2	1707	0.7
B65R	68.1	1730	0.7
B66R	69.1	1755	0.7
B67R	70	1778	0.7
B68R	70.9	1801	0.7
B69R	71.9	1826	0.7
B70R	73.1	1857	0.8
B71R	74.1	1882	0.8
B72R	75	1905	0.8
B73R	76	1930	0.8
B74R	76.9	1953	0.8
B75R	77.9	1979	0.8
B76R	79.1	2009	0.8
B77R	80.1	2035	0.9
B78R	81	2057	0.9
B79R	81.9	2080	0.8
B80R	83.1	2111	0.9
B81R	83.8	2129	0.9
B82R	85.3	2167	0.9
B83R	86.2	2190	0.9
B84R	87.1	2212	0.9
B85R	88.1	2238	0.9
B86R	89	2261	1.0
B87R	90.3	2294	1.0
B88R	91.2	2317	1.0
B89R	92.2	2342	1.0
B90R	93.1	2365	1.0
B91R	94.1	2390	1.0
B92R	95	2413	1.0
B93R	95.9	2436	1.0
B94R	97.2	2469	1.0
B95R	98.1	2492	1.0

Part Number	Outside Circumference (inches)	Outside Circumference (mm)	Weight (lbs.)
B-R Section – Recommended Sheaves: Conventional – QD, Taper Bushed, or MST (A-B)			
B96R	99.4	2525	1.1
B97R	100	2540	1.1
B98R	101	2565	1.1
B99R	102.2	2596	1.1
B100R	103	2616	1.1
B101R	104.1	2644	1.1
B103R	106.3	2700	1.1
B105R	108.2	2748	1.2
B106R	109.1	2771	1.2
B108R	111	2819	1.2
B112R	115	2921	1.2
B115R	117.9	2995	1.3
B116R	119.2	3028	1.3
B118R	121	3073	1.3
B120R	123.1	3127	1.3
B123R	126.1	3203	1.4
B124R	127.1	3228	1.4
B126R	129.1	3279	1.4
B128R	131.1	3330	1.4
B130R	133.1	3381	1.4
B133R	136.1	3457	1.5
B136R	139.1	3533	1.5
B140R	143.1	3635	1.5
B142R	145.1	3686	1.6
B143R	146.1	3711	1.6
B144R	147.1	3736	1.6
B148R	151.1	3838	1.6
B150R	153.1	3889	1.6
B154R	157.1	3990	1.7
B156R	159.1	4041	1.7
B158R	161.1	4092	1.7
B162R	165.1	4194	1.8
B173R	176.1	4473	1.9

Super II® V-Belt

Super II® V-Belt Part Numbers

Part Number Example: **C100R** = **C** **100** **R**
Cross Section Inside Circumference (inches) Raw Edge Construction

Part Number	Outside Circumference (inches)	Outside Circumference (mm)	Weight (lbs.)
B-R Section – Recommended Sheaves: Conventional – QD, Taper Bushed, or MST (A-B)			
B180R	183.1	4651	2.0
B188R	191.1	4854	2.1
B191R	194.1	4930	2.1
B195R	198.1	5032	2.1
C-R Section – Recommended Sheaves: Conventional – QD, Taper Bushed, or MST (C)			
C51R	55.2	1402	1.1
C55R	59.3	1506	1.2
C59R	63	1600	1.2
C60R	64.3	1633	1.3
C68R	72.1	1831	1.4
C72R	76.2	1936	1.5
C75R	79	2007	1.6
C78R	82.2	2088	1.6
C81R	85.3	2167	1.7
C85R	89.1	2263	1.8
C90R	94.2	2393	1.9
C93R	97.2	2469	1.5
C96R	100.2	2545	2.0
C97R	101.1	2568	2.0
C100R	104.3	2649	2.1
C101R	105.2	2672	2.1
C105R	109	2769	2.2
C108R	112.2	2850	1.8
C109R	113.4	2880	2.2
C111R	115.3	2929	2.3
C112R	116.2	2952	2.3
C115R	119.2	3028	2.4
C120R	124.2	3155	2.5
C124R	128.2	3256	2.5
C128R	132.2	3358	2.6
C136R	140.2	3561	2.8

Part Number	Outside Circumference (inches)	Outside Circumference (mm)	Weight (lbs.)
C-R Section – Recommended Sheaves: Conventional – QD, Taper Bushed, or MST (C)			
C144R	148.2	3764	2.9
C148R	152.2	3866	3.0
C150R	154.2	3917	3.1
C152R	156.2	3968	3.1
C158R	162.2	4120	3.2
C160R	164.2	4171	3.3
C162R	166.2	4222	3.3
C173R	177.2	4501	3.5
C180R	184.2	4679	3.7
C195R	199.2	5060	4.0

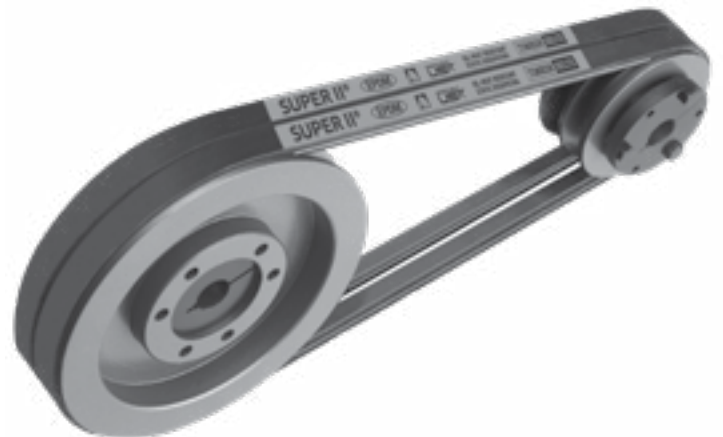

Super Blue Ribbon® V-Belt

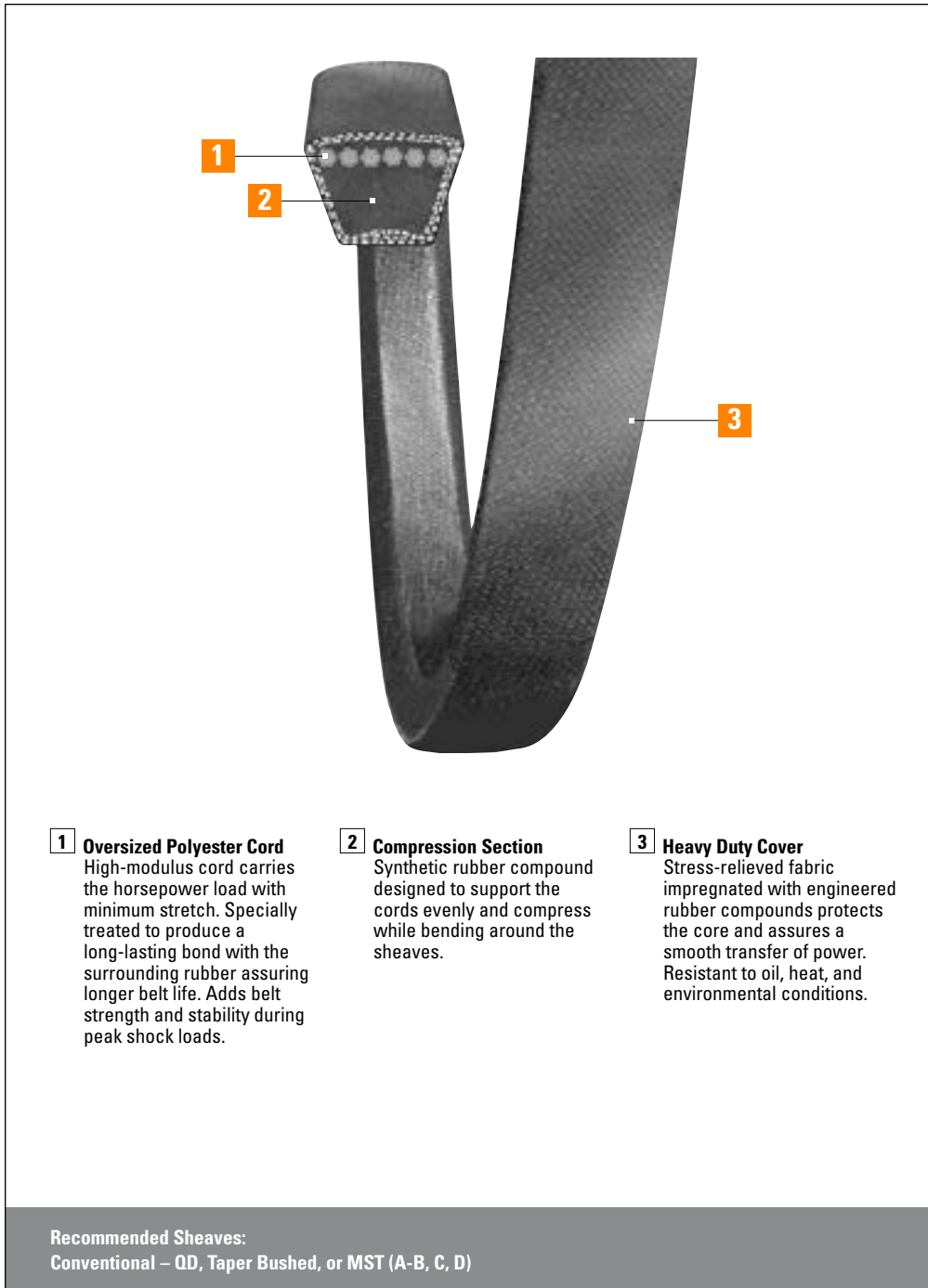

1 Oversized Polyester Cord
High-modulus cord carries the horsepower load with minimum stretch. Specially treated to produce a long-lasting bond with the surrounding rubber assuring longer belt life. Adds belt strength and stability during peak shock loads.

2 Compression Section
Synthetic rubber compound designed to support the cords evenly and compress while bending around the sheaves.

3 Heavy Duty Cover
Stress-relieved fabric impregnated with engineered rubber compounds protects the core and assures a smooth transfer of power. Resistant to oil, heat, and environmental conditions.

Recommended Sheaves:
Conventional – OD, Taper Bushed, or MST (A-B, C, D)

Dependable performance on classical v-belt drives

Long life

chekmate®

Heavy duty cover

Oil and heat resistant

Smooth running

Applications:

- Mixers
- Pumps
- Conveyors
- HVAC
- Anything and everything & More

Super Blue Ribbon®

V-Belt

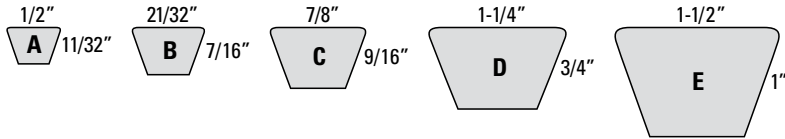

Premium wrapped molded v-belt built to the highest standards in the industry. Ideal for classical drives with shock loads.

Super Blue Ribbon v-belts assure dependable length stability and require less re-tensioning and take-up. The cord is coated with a special compound that produces a secure, long-lasting bond with the surrounding rubber. The heavy-duty stress-relieved fabric cover protects the core and assures a smooth transfer of power. Its extra flexibility permits the belt to bend more easily around the smallest pulleys with less strain on the fabric. Long belt life results in less frequent replacement, less downtime and lower maintenance costs.

Super Blue Ribbon v-belts operate within a wide range of load capacities and speeds – with rated performance from 100 to 8,000 RPM and horsepower capability from 1 to 1,100 horsepower.

Super Blue Ribbon is the ideal choice for dependable performance on an extremely wide range of applications – A, B, C, D, and E cross sections – single or multiple belt drives.



Super Blue Ribbon® V-Belt

Super Blue Ribbon® V-Belt Part Numbers

Part Number Example: **A50** = **A** **50**
↑ Cross Section ↑ Inside Circumference (inches)

Part Number	Legacy Part Number	Outside Circumference (inches)	Outside Circumference (mm)	Weight (lbs.)
A Section – Recommended Sheaves: Conventional – QD, Taper Bushed, or MST (A-B)				
A20	AP20	22.3	566	0.1
A21	AP21	23.6	599	0.1
A22	AP22	24.4	620	0.1
A23	AP23	25.5	648	0.2
A24	AP24	26.5	673	0.2
A25	AP25	27.5	699	0.2
A26	AP26	28.6	726	0.2
A27	AP27	29.7	754	0.2
A28	AP28	30.6	777	0.2
A29	AP29	31.5	800	0.2
A30	AP30	32.6	828	0.2
A31	AP31	33.6	853	0.2
A32	AP32	34.5	876	0.2
A33	AP33	35.6	904	0.2
A34	AP34	36.5	927	0.2
A35	AP35	37.6	955	0.2
A36	AP36	38.6	980	0.2
A37	AP37	39.5	1003	0.2
A38	AP38	40.4	1026	0.2
A39	AP39	41.6	1057	0.3
A40	AP40	42.6	1082	0.3
A41	AP41	43.5	1105	0.3
A42	AP42	44.5	1130	0.3
A43	AP43	45.5	1156	0.3
A44	AP44	46.6	1184	0.3
A45	AP45	47.4	1204	0.3
A46	AP46	48.5	1232	0.3
A47	AP47	49.5	1257	0.3
A48	AP48	50.5	1283	0.3
A49	AP49	51.5	1308	0.3
A50	AP50	52.3	1328	0.3
A51	AP51	53.6	1361	0.3
A52	AP52	54.6	1387	0.3

Part Number	Legacy Part Number	Outside Circumference (inches)	Outside Circumference (mm)	Weight (lbs.)
A Section – Recommended Sheaves: Conventional – QD, Taper Bushed, or MST (A-B)				
A53	AP53	55.6	1412	0.3
A54	AP54	56.6	1438	0.3
A55	AP55	57.6	1463	0.4
A56	AP56	58.6	1488	0.4
A57	AP57	59.5	1511	0.4
A58	AP58	60.3	1532	0.4
A59	AP59	61.5	1562	0.4
A60	AP60	62.5	1588	0.4
A61	AP61	63.6	1615	0.4
A62	AP62	64.6	1641	0.4
A63	AP63	65.6	1666	0.4
A64	AP64	66.6	1692	0.4
A65	AP65	67.6	1717	0.4
A66	AP66	68.5	1740	0.4
A67	AP67	69.6	1768	0.4
A68	AP68	70.5	1791	0.4
A69	AP69	71.4	1814	0.4
A70	AP70	72.6	1844	0.4
A71	AP71	73.6	1869	0.5
A72	AP72	74.5	1892	0.5
A73	AP73	75.5	1918	0.5
A74	AP74	76.6	1946	0.5
A75	AP75	77.7	1974	0.5
A76	AP76	78.4	1991	0.5
A77	AP77	79.5	2019	0.5
A78	AP78	80.5	2045	0.5
A79	AP79	81.7	2075	0.5
A80	AP80	82.5	2096	0.5
A81	AP81	83.7	2126	0.5
A82	AP82	84.6	2149	0.5
A83	AP83	85.4	2169	0.5
A84	AP84	86.5	2197	0.5
A84.5	AP84.5	87	2210	0.5

Super Blue Ribbon®

V-Belt

Super Blue Ribbon® V-Belt Part Numbers

Part Number	Legacy Part Number	Outside Circumference (inches)	Outside Circumference (mm)	Weight (lbs.)
A Section – Recommended Sheaves: Conventional – QD, Taper Bushed, or MST (A-B)				
A85	AP85	87.7	2228	0.5
A86	AP86	88.5	2248	0.5
A87	AP87	89.6	2276	0.5
A88	AP88	90.5	2299	0.6
A89	AP89	91.5	2324	0.6
A90	AP90	92.7	2355	0.6
A91	AP91	93.6	2377	0.6
A92	AP92	94.6	2403	0.6
A93	AP93	95.6	2428	0.6
A94	AP94	96.6	2454	0.6
A95	AP95	97.6	2479	0.6
A96	AP96	98.6	2504	0.6
A97	AP97	99.6	2530	0.6
A98	AP98	100.6	2555	0.6
A99	AP99	101.3	2573	0.6
A100	AP100	102.5	2604	0.6
A101	AP101	103.5	2629	0.6
A102	AP102	104.7	2659	0.6
A103	AP103	105.5	2680	0.6
A104	AP104	106.4	2703	0.7
A105	AP105	107.6	2733	0.7
A108	AP108	110.3	2802	0.7
A110	AP110	112.5	2858	0.7
A112	AP112	114.5	2908	0.7
A114	AP114	116.4	2957	0.7
A115	AP115	117.4	2982	0.7
A116	AP116	118.4	3007	0.7
A118	AP118	120.4	3058	0.7
A120	AP120	122.7	3117	0.8
A124	AP124	126.4	3211	0.8
A125	AP125	127.3	3233	0.8
A126	AP126	128.3	3259	0.8

Part Number	Legacy Part Number	Outside Circumference (inches)	Outside Circumference (mm)	Weight (lbs.)
A Section – Recommended Sheaves: Conventional – QD, Taper Bushed, or MST (A-B)				
A127	AP127	129.3	3284	0.8
A128	AP128	130.4	3312	0.8
A130	AP130	132.3	3360	0.8
A133	AP133	135.4	3439	0.8
A134	AP134	136.4	3465	0.8
A136	AP136	138.3	3513	0.9
A140	AP140	142.4	3617	0.9
A141	AP141	143.1	3635	0.9
A144	AP144	146.4	3719	0.9
A148	AP148	150.2	3815	0.9
A158	AP158	160.2	4069	1.0
A162	AP162	164.2	4171	1.0
A173	AP173	175.2	4450	1.1
A180	AP180	182.2	4628	1.1
A220	AP220	222.2	5644	1.4
A237	AP237	239.4	6081	1.5
B Section – Recommended Sheaves: Conventional – QD, Taper Bushed, or MST (A-B)				
B23	BP23	26.4	671	0.2
B24	BP24	27.4	696	0.2
B25	BP25	28.4	721	0.2
B26	BP26	29.5	749	0.2
B27	BP27	30.3	770	0.2
B28	BP28	31.3	795	0.3
B29	BP29	32.4	823	0.3
B30	BP30	33.4	848	0.3
B31	BP31	34.5	876	0.3
B32	BP32	35.4	899	0.3
B33	BP33	36.2	920	0.4
B34	BP34	37	940	0.3
B35	BP35	38.4	975	0.4
B36	BP36	39.3	998	0.4

Super Blue Ribbon®

V-Belt

Part Number Example: **B50** = **B** **50**
Cross Section Inside Circumference (inches)

Part Number	Legacy Part Number	Outside Circumference (inches)	Outside Circumference (mm)	Weight (lbs.)
B Section – Recommended Sheaves: Conventional – QD, Taper Bushed, or MST (A-B)				
B37	BP37	40.4	1026	0.4
B38	BP38	41.4	1052	0.4
B39	BP39	42.4	1077	0.4
B40	BP40	43.3	1100	0.4
B41	BP41	43.8	1113	0.4
B42	BP42	44.9	1141	0.4
B43	BP43	46.4	1179	0.5
B44	BP44	47.2	1199	0.5
B45	BP45	48.3	1227	0.5
B46	BP46	49.3	1252	0.5
B47	BP47	49.8	1265	0.5
B48	BP48	51.1	1298	0.5
B49	BP49	52.1	1323	0.5
B50	BP50	53	1346	0.5
B51	BP51	54.2	1377	0.5
B52	BP52	54.8	1392	0.5
B53	BP53	56	1422	0.6
B54	BP54	57.1	1450	0.5
B55	BP55	58	1473	0.6
B56	BP56	59.3	1506	0.6
B57	BP57	60.3	1532	0.6
B58	BP58	61.3	1557	0.6
B59	BP59	61.9	1572	0.6
B60	BP60	63.3	1608	0.6
B61	BP61	63.9	1623	0.6
B62	BP62	65	1651	0.7
B63	BP63	66	1676	0.6
B64	BP64	67.3	1709	0.7
B65	BP65	68.3	1735	0.7
B66	BP66	69.2	1758	0.7
B67	BP67	70.4	1788	0.7
B68	BP68	71.1	1806	0.7

Part Number	Legacy Part Number	Outside Circumference (inches)	Outside Circumference (mm)	Weight (lbs.)
B Section – Recommended Sheaves: Conventional – QD, Taper Bushed, or MST (A-B)				
B69	BP69	72.5	1842	0.7
B70	BP70	73.1	1857	0.7
B71	BP71	74.2	1885	0.7
B72	BP72	75.4	1915	0.8
B73	BP73	76.2	1936	0.8
B74	BP74	77.3	1963	0.8
B75	BP75	78.3	1989	0.8
B76	BP76	79.2	2012	0.8
B77	BP77	80.4	2042	0.8
B78	BP78	81.4	2068	0.8
B79	BP79	82.4	2093	0.8
B80	BP80	83.4	2118	0.8
B81	BP81	84.4	2144	0.8
B82	BP82	85.3	2167	0.9
B83	BP83	86.3	2192	0.9
B84	BP84	87.3	2217	0.9
B85	BP85	88.3	2243	0.9
B86	BP86	89.4	2271	0.9
B87	BP87	90.4	2296	0.9
B88	BP88	91.4	2322	0.9
B89	BP89	92.4	2347	0.9
B90	BP90	93.4	2372	0.9
B91	BP91	94	2388	0.9
B92	BP92	95.3	2421	1.0
B93	BP93	96.3	2446	1.0
B94	BP94	97.1	2466	1.0
B95	BP95	98.3	2497	1.0
B96	BP96	99.3	2522	1.0
B97	BP97	100.2	2545	1.0
B98	BP98	100.9	2563	1.0
B99	BP99	102	2591	1.0
B100	BP100	103.3	2624	1.0

Super Blue Ribbon®

V-Belt

Super Blue Ribbon® V-Belt Part Numbers

Part Number	Legacy Part Number	Outside Circumference (inches)	Outside Circumference (mm)	Weight (lbs.)
B Section – Recommended Sheaves: Conventional – QD, Taper Bushed, or MST (A-B)				
B101	BP101	104	2642	1.0
B102	BP102	105.2	2672	1.0
B103	BP103	106.2	2698	1.1
B104	BP104	107	2718	1.1
B105	BP105	108.1	2746	1.1
B106	BP106	109	2769	1.1
B107	BP107	110	2794	1.1
B108	BP108	111.5	2832	1.1
B109	BP109	112	2845	1.1
B110	BP110	112.8	2865	1.1
B111	BP111	114.2	2901	1.1
B112	BP112	115.2	2926	1.2
B113	BP113	116	2946	1.2
B114	BP114	117	2972	1.2
B115	BP115	118.1	3000	1.2
B116	BP116	119.1	3025	1.2
B117	BP117	120	3048	1.2
B118	BP118	121	3073	1.2
B119	BP119	122	3099	1.2
B120	BP120	123.1	3127	1.2
B122	BP122	125	3175	1.2
B123	BP123	126	3200	1.3
B124	BP124	126.9	3223	1.3
B125	BP125	128	3251	1.3
B126	BP126	129	3277	1.3
B128	BP128	130.9	3325	1.3
B130	BP130	133	3378	1.3
B131	BP131	134	3404	1.3
B132	BP132	135	3429	1.3
B133	BP133	136	3454	1.4
B134	BP134	137	3480	1.4
B135	BP135	138	3505	1.4

Part Number	Legacy Part Number	Outside Circumference (inches)	Outside Circumference (mm)	Weight (lbs.)
B Section – Recommended Sheaves: Conventional – QD, Taper Bushed, or MST (A-B)				
B136	BP136	139	3531	1.4
B138	BP138	141	3581	1.4
B140	BP140	143.2	3637	1.4
B141	BP141	143.6	3647	1.4
B142	BP142	145	3683	1.4
B144	BP144	147.1	3736	1.5
B146	BP146	149	3785	1.5
B148	BP148	151	3835	1.5
B150	BP150	153	3886	1.5
B151	BP151	154	3912	1.5
B152	BP152	155	3937	1.5
B154	BP154	157	3988	1.6
B156	BP156	159	4039	1.6
B157	BP157	160	4064	1.6
B158	BP158	161	4089	1.6
B160	BP160	163	4140	1.6
B161	BP161	164	4166	1.6
B162	BP162	165	4191	1.6
B164	BP164	167	4242	1.7
B165	BP165	168	4267	1.7
B168	BP168	171	4343	1.7
B170	BP170	173	4394	1.7
B172	BP172	175	4445	1.7
B173	BP173	176	4470	1.8
B175	BP175	178	4521	1.8
B176	BP176	179	4547	1.8
B177	BP177	180	4572	1.8
B180	BP180	183	4648	1.8
B182	BP182	185	4699	1.8
B184	BP184	187	4750	1.9
B190	BP190	193	4902	1.9
B191	BP191	194	4928	1.9

Super Blue Ribbon®

V-Belt

Part Number Example: **C50** = $\begin{matrix} \text{C} \\ \downarrow \\ \text{Cross} \\ \text{Section} \end{matrix}$ $\begin{matrix} 50 \\ \downarrow \\ \text{Inside Circumference} \\ \text{(inches)} \end{matrix}$

Part Number	Legacy Part Number	Outside Circumference (inches)	Outside Circumference (mm)	Weight (lbs.)
B Section – Recommended Sheaves: Conventional – QD, Taper Bushed, or MST (A-B)				
B195	BP195	198	5029	2.0
B197	BP197	200	5080	2.0
B198	BP198	201	5105	2.0
B202	BP202	205	5207	2.0
B203	BP203	206	5232	2.1
B205	BP205	208	5283	2.1
B210	BP210	213	5410	2.1
B214	BP214	217	5512	2.2
B215	BP215	218	5537	2.2
B217	BP217	220	5588	2.2
B220	BP220	223	5664	2.2
B221	BP221	224	5690	2.2
B223	BP223	224.5	5702	2.2
B224	BP224	225.5	5728	2.2
B225	BP225	226.5	5753	2.3
B228	BP228	231	5867	2.3
B240	BP240	241.5	6134	2.4
B244	BP244	245.5	6236	2.4
B250	BP250	253	6426	2.5
B253	BP253	256	6502	2.6
B255	BP255	256.5	6515	2.6
B265	BP265	268	6807	2.7
B270	BP270	271.5	6896	2.7
B275	BP275	276.5	7023	2.8
B280	BP280	281.5	7150	2.8
B285	BP285	286.5	7277	2.9
B300	BP300	301.5	7658	3.0
B315	BP315	316.5	8039	3.2
B330	BP330	331.5	8420	3.3
B360	BP360	361.5	9182	3.7
B433	BP433	436	11074	4.4
B443	BP443	446	11328	4.5

Part Number	Legacy Part Number	Outside Circumference (inches)	Outside Circumference (mm)	Weight (lbs.)
B Section – Recommended Sheaves: Conventional – QD, Taper Bushed, or MST (A-B)				
B512	BP512	513.5	13043	5.2
B543	BP543	544.5	13830	5.5
B553	BP553	554.5	14084	5.6
C Section – Recommended Sheaves: Conventional – QD, Taper Bushed, or MST (C)				
C46	CP46	50.3	1278	0.8
C50	CP50	54.5	1384	0.9
C51	CP51	55.6	1412	1.0
C53	CP53	57.4	1458	1.0
C54	CP54	58.8	1494	1.0
C55	CP55	59.7	1516	1.1
C56	CP56	59.9	1522	1.0
C57	CP57	61.1	1552	1.0
C58	CP58	63	1600	1.0
C60	CP60	64.6	1641	1.1
C61	CP61	65.3	1659	1.2
C62	CP62	66.8	1697	1.2
C63	CP63	67.6	1717	1.2
C64	CP64	68.6	1742	1.2
C65	CP65	69.6	1768	1.1
C66	CP66	70.1	1781	1.2
C67	CP67	71.8	1824	1.3
C68	CP68	72.7	1847	1.3
C69	CP69	73.3	1862	1.3
C70	CP70	74.8	1900	1.3
C71	CP71	75.6	1920	1.3
C72	CP72	76.6	1946	1.4
C73	CP73	77.7	1974	1.4
C74	CP74	78.2	1986	1.4
C75	CP75	79.6	2022	1.4
C76	CP76	80.6	2047	1.4
C77	CP77	81.6	2073	1.5

Super Blue Ribbon®

V-Belt

Super Blue Ribbon® V-Belt Part Numbers

Part Number	Legacy Part Number	Outside Circumference (inches)	Outside Circumference (mm)	Weight (lbs.)
C Section – Recommended Sheaves: Conventional – QD, Taper Bushed, or MST (C)				
C78	CP78	82.6	2098	1.5
C79	CP79	83.4	2118	1.5
C80	CP80	84.2	2139	1.5
C81	CP81	85.5	2172	1.5
C82	CP82	86.3	2192	1.5
C83	CP83	87.4	2220	1.6
C84	CP84	88.6	2250	1.6
C85	CP85	89.5	2273	1.6
C86	CP86	90.5	2299	1.6
C87	CP87	91.5	2324	1.6
C88	CP88	92.6	2352	1.7
C89	CP89	93.6	2377	1.7
C90	CP90	94.4	2398	1.7
C91	CP91	95.4	2423	1.7
C92	CP92	97	2464	1.7
C93	CP93	97.7	2482	1.7
C94	CP94	98.6	2504	1.8
C95	CP95	99.9	2538	1.8
C96	CP96	100.4	2550	1.8
C97	CP97	101.5	2578	1.8
C98	CP98	102.5	2604	1.8
C99	CP99	103.9	2639	1.9
C100	CP100	104.9	2665	1.9
C101	CP101	105.8	2687	1.9
C102	CP102	106.5	2705	1.9
C103	CP103	107.5	2731	1.9
C104	CP104	108.5	2756	1.9
C105	CP105	109.5	2781	2.0
C106	CP106	110.2	2799	2.0
C107	CP107	111.5	2832	2.0
C108	CP108	112.8	2865	2.0
C109	CP109	113.7	2888	2.0

Part Number	Legacy Part Number	Outside Circumference (inches)	Outside Circumference (mm)	Weight (lbs.)
C Section – Recommended Sheaves: Conventional – QD, Taper Bushed, or MST (C)				
C110	CP110	114.6	2911	2.0
C111	CP111	115.5	2934	2.1
C112	CP112	116.4	2957	2.1
C113	CP113	117.5	2985	2.1
C114	CP114	118.5	3010	2.1
C115	CP115	119.5	3035	2.1
C116	CP116	120.5	3061	2.2
C117	CP117	121.5	3086	2.2
C118	CP118	122.6	3114	2.2
C119	CP119	123.5	3137	2.2
C120	CP120	124.4	3160	2.2
C121	CP121	125.4	3185	2.3
C122	CP122	126.4	3211	2.3
C123	CP123	127.6	3241	2.3
C124	CP124	128.5	3264	2.3
C125	CP125	129.6	3292	2.3
C126	CP126	130.6	3317	2.3
C127	CP127	131.5	3340	2.4
C128	CP128	132.2	3358	2.4
C129	CP129	133.6	3393	2.4
C130	CP130	134.6	3419	2.4
C131	CP131	136	3454	2.4
C132	CP132	136.6	3470	2.4
C133	CP133	137.6	3495	2.5
C134	CP134	138.5	3518	2.5
C135	CP135	139.6	3546	2.5
C136	CP136	140.2	3561	2.5
C137	CP137	141.6	3597	2.5
C138	CP138	143.1	3635	2.6
C139	CP139	143.3	3640	2.6
C140	CP140	144.2	3663	2.6
C141	CP141	145.3	3691	2.6

Super Blue Ribbon®

V-Belt

Part Number Example: **C200** = **C** **200**
Cross Section Inside Circumference (inches)

Part Number	Legacy Part Number	Outside Circumference (inches)	Outside Circumference (mm)	Weight (lbs.)
C Section – Recommended Sheaves: Conventional – QD, Taper Bushed, or MST (C)				
C142	CP142	146.3	3716	2.6
C143	CP143	147.3	3741	2.6
C144	CP144	148.2	3764	2.7
C145	CP145	149.3	3792	2.7
C146	CP146	150.3	3818	2.7
C147	CP147	151.2	3841	2.7
C148	CP148	152.3	3868	2.7
C149	CP149	153.3	3894	2.8
C150	CP150	154.3	3919	2.8
C151	CP151	155.3	3945	2.8
C152	CP152	156.3	3970	2.8
C153	CP153	157.3	3995	2.8
C154	CP154	158.3	4021	2.8
C155	CP155	159.3	4046	2.9
C156	CP156	160.3	4072	2.9
C157	CP157	161.3	4097	2.9
C158	CP158	162.3	4122	2.9
C159	CP159	163.3	4148	2.9
C160	CP160	164.3	4173	3.0
C161	CP161	165.3	4199	3.0
C162	CP162	166.3	4224	3.0
C163	CP163	167.3	4249	3.0
C164	CP164	168.3	4275	3.0
C165	CP165	169.3	4300	3.0
C166	CP166	170.3	4326	3.1
C167	CP167	171.3	4351	3.1
C168	CP168	172.3	4376	3.1
C169	CP169	173.3	4402	3.1
C170	CP170	174.3	4427	3.1
C171	CP171	175.3	4453	3.2
C172	CP172	176.3	4478	3.2
C173	CP173	177.3	4503	3.2

Part Number	Legacy Part Number	Outside Circumference (inches)	Outside Circumference (mm)	Weight (lbs.)
C Section – Recommended Sheaves: Conventional – QD, Taper Bushed, or MST (C)				
C174	CP174	178.3	4529	3.2
C175	CP175	179.3	4554	3.2
C176	CP176	180.3	4580	3.2
C177	CP177	181.3	4605	3.3
C178	CP178	182.3	4630	3.3
C179	CP179	183.3	4656	3.3
C180	CP180	184.3	4681	3.3
C181	CP181	185.4	4709	3.3
C182	CP182	186.3	4732	3.4
C183	CP183	187.3	4757	3.4
C184	CP184	188.3	4783	3.4
C185	CP185	189.3	4808	3.4
C186	CP186	190.3	4834	3.4
C187	CP187	191.3	4859	3.4
C188	CP188	192.3	4884	3.5
C189	CP189	193.3	4910	3.5
C190	CP190	194.3	4935	3.5
C192	CP192	196.3	4986	3.5
C193	CP193	197.3	5011	3.6
C194	CP194	198.3	5037	3.6
C195	CP195	199.3	5062	3.6
C196	CP196	200.1	5083	3.6
C197	CP197	201.3	5113	3.6
C198	CP198	202.3	5138	3.7
C199	CP199	203.3	5164	3.6
C200	CP200	204.3	5189	3.7
C204	CP204	208.3	5291	3.8
C205	CP205	209.3	5316	3.8
C208	CP208	212.3	5392	3.8
C210	CP210	214.3	5443	3.9
C215	CP215	219.3	5570	4.0
C218	CP218	222.3	5646	4.0

Super Blue Ribbon®

V-Belt

Super Blue Ribbon® V-Belt Part Numbers

Part Number	Legacy Part Number	Outside Circumference (inches)	Outside Circumference (mm)	Weight (lbs.)
C Section – Recommended Sheaves: Conventional – QD, Taper Bushed, or MST (C)				
C220	CP220	224.3	5697	4.1
C225	CP225	227.3	5773	4.1
C228	CP228	230.3	5850	4.2
C230	CP230	232.3	5900	4.2
C235	CP235	237.3	6027	4.3
C236	CP236	238.3	6053	4.3
C240	CP240	242.3	6154	4.4
C245	CP245	247.3	6281	4.5
C248	CP248	250.3	6358	4.5
C250	CP250	252.3	6408	4.6
C255	CP255	257.3	6535	4.7
C260	CP260	262.3	6662	4.7
C264	CP264	266.5	6769	4.8
C265	CP265	267.6	6797	4.8
C269	CP269	271.5	6896	4.9
C270	CP270	272.5	6922	4.9
C275	CP275	277.6	7051	5.0
C276	CP276	278.5	7074	5.0
C280	CP280	282.5	7176	5.1
C285	CP285	287.5	7303	5.2
C290	CP290	292.6	7432	5.3
C297	CP297	299.5	7607	5.4
C300	CP300	302.5	7684	5.5
C314	CP314	316.5	8039	5.7
C315	CP315	317.5	8065	5.7
C330	CP330	332.5	8446	6.0
C340	CP340	342.5	8700	6.2
C345	CP345	347.5	8827	6.3
C360	CP360	362.5	9208	6.6
C390	CP390	392.5	9970	7.2
C420	CP420	422.5	10732	7.8

Part Number	Legacy Part Number	Outside Circumference (inches)	Outside Circumference (mm)	Weight (lbs.)
D Section – Recommended Sheaves: Conventional – QD, Taper Bushed, or MST (D)				
D88	DP88	93.5	2375	3.0
D90	DP90	95.5	2426	3.1
D96	DP96	101.5	2578	3.3
D98	DP98	103.5	2629	3.3
D100	DP100	105.5	2680	3.4
D101	DP101	106.5	2705	3.4
D104	DP104	109.5	2781	3.5
D105	DP105	110.5	2807	3.6
D108	DP108	113.5	2883	3.7
D112	DP112	117.5	2985	3.8
D115	DP115	120.5	3061	3.9
D120	DP120	125.5	3188	4.3
D124	DP124	129.5	3289	4.1
D128	DP128	133.4	3388	4.6
D132	DP132	137.5	3493	4.5
D134	DP134	139.5	3543	4.5
D135	DP135	140.5	3569	4.6
D136	DP136	141.5	3594	4.6
D140	DP140	145.5	3696	4.7
D144	DP144	149.2	3790	4.8
D152	DP152	157.2	3993	5.1
D154	DP154	159.2	4044	5.1
D157	DP157	162.2	4120	5.3
D158	DP158	163.2	4145	5.3
D160	DP160	165.5	4204	5.4
D162	DP162	167.2	4247	5.4
D164	DP164	169.5	4305	5.5
D165	DP165	170.5	4331	5.5
D166	DP166	171.2	4349	5.6
D168	DP168	173.2	4399	5.6
D170	DP170	175.2	4450	5.7

Super Blue Ribbon®

V-Belt

Part Number Example: **D300** = **D** **300**
Cross Section Inside Circumference (inches)

Part Number	Legacy Part Number	Outside Circumference (inches)	Outside Circumference (mm)	Weight (lbs.)
D Section – Recommended Sheaves: Conventional – QD, Taper Bushed, or MST (D)				
D171	DP171	176.2	4476	5.7
D173	DP173	178.2	4526	5.8
D177	DP177	182.2	4628	5.9
D178	DP178	183.2	4653	6.0
D180	DP180	185.2	4704	6.0
D189	DP189	194.2	4933	6.3
D195	DP195	200.2	5085	6.5
D210	DP210	215.2	5466	7.0
D225	DP225	227.7	5784	7.4
D230	DP230	232.7	5911	7.6
D240	DP240	242.7	6165	7.9
D248	DP248	250.7	6368	8.0
D255	DP255	257.7	6546	8.4
D260	DP260	262.7	6673	8.6
D270	DP270	272.7	6927	8.9
D280	DP280	282.7	7181	9.2
D285	DP285	287.7	7308	9.4
D300	DP300	302.7	7689	9.9
D315	DP315	317.7	8070	10.4
D330	DP330	332.7	8451	10.9
D345	DP345	347.7	8832	11.4
D360	DP360	362.7	9213	12.0
D390	DP390	392.7	9975	13.0
D420	DP420	422.7	10737	14.0
D450	DP450	453	11506	15.2
D480	DP480	483	12268	16.2
D540	DP540	543	13792	18.2
D660	DP660	663	16840	22.3

Part Number	Legacy Part Number	Outside Circumference (inches)	Outside Circumference (mm)	Weight (lbs.)
E Section – Recommended Sheaves: Conventional – QD, Taper Bushed, or MST (E*)				
E144	EP144	151.2	3841	7.9
E180	EP180	187.2	4755	9.8
E210	EP210	217.2	5517	11.4
E225	EP225	228.7	5809	12.0
E240	EP240	243.7	6190	12.8
E250	EP250	253.7	6444	13.0
E270	EP270	273.7	6952	14.4
E300	EP300	303.7	7714	16.0
E330	EP330	333.7	8476	17.6
E360	EP360	363.7	9238	19.3
E376	EP376	379.7	9644	20.2
E390	EP390	393.7	10000	20.9
E420	EP420	423.7	10762	22.5
E480	EP480	483.7	12286	25.7
E540	EP540	543.7	13810	29.0
E660	EP660	663.7	16858	35.4

Super Blue Ribbon® Band

Banded Belt



Super Blue Ribbon® Band Banded Belt

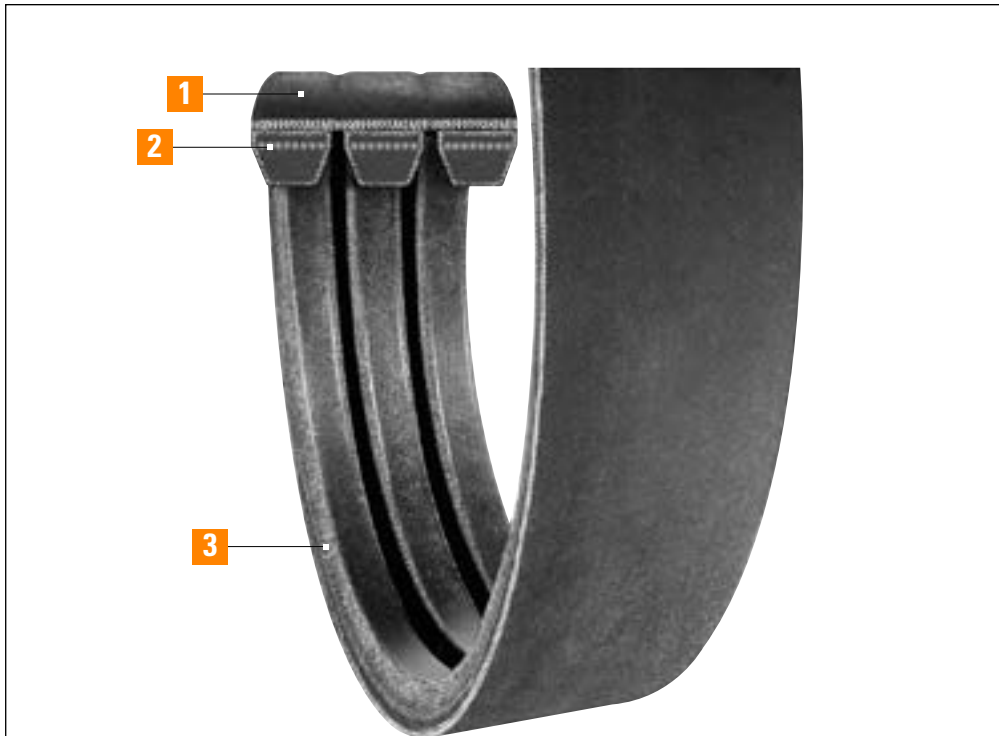

1 Reinforced Tie-Band

Highly engineered tie-band permanently bonds or “ties” multiple belts together. This assures smooth operation enabling the belts to function as a single unit, with even load distribution and wear. Vibration is dampened. Heavy shock loads are absorbed. Belt whip and turnover are minimized.

2 Oversized Polyester Cord

High-modulus cord carries the horsepower load with minimum stretch. Specially treated to produce a long-lasting bond with the surrounding rubber assuring longer belt life. Adds belt strength and stability during peak shock loads

3 Heavy Duty Cover

Stress-relieved fabric impregnated with engineered rubber compounds protects the core and assures a smooth transfer of power. Resistant to oil, heat, and environmental conditions.

Recommended Pulleys:

Conventional – OD, Taper Bushed, or MST (A-B, C, D)

Banded version of Super Blue Ribbon V-Belt

Provides cross-wise rigidity for multiple belt drives

Minimizes belt turnover and whip

Smooth transfer of power

Long belt life

Wear resistant

Available in a wide range of sizes

Applications:

Rock crushers
Vibrating equipment
Saws
Pumps
& More

Super Blue Ribbon® Band

Banded Belt

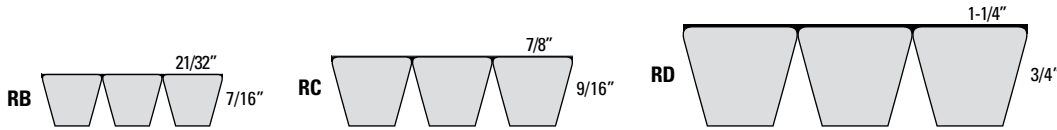

Two or more Super Blue Ribbon v-belts are permanently joined together at the top with a reinforced tie-band. Ideally suited for pulsating or heavily shock loaded drives and drives with long center distances to minimize belt whip and rollover.

Super Blue Ribbon® banded belts are specifically designed to handle tough industrial applications like rock crushers, vibrating equipment, saws and pumps.

Super Blue Ribbon Band belts combine the long life and superior performance of Super Blue Ribbon v-belts with the stability of a banded belt. The specially compounded wrapped construction is ideal for clutching operations. Banded belts assure that each rib is sharing the load equally to achieve the full horsepower capacity of the drive. The reinforced band across the top greatly enhances stability by minimizing belt whip and turnover.

The static-dissipating Super Blue Ribbon Band provides superior resistance to oil and heat which is critical in these tough industrial applications.

For complete part number, add the number of ribs required. For example, RB100-3.



Super Blue Ribbon Band Matching Limits

Matching limits for Super Blue Ribbon banded belts are shown in the table. If the number is 1, the bands must all have the same “sag” number. If the number is 2, a matched set may consist of any 2 adjacent matching numbers, etc.

Product Type and Length Code	Match Limit
Super Vee- Band®	
RB35-RB60	1
RB61 - RB144	2
RB148 and up	3
RC51 - RC60	1
RC68 - RC144	2
RC158 and up	3
RD120-RD144	2
RD158 and up	3

Super Blue Ribbon® Band Banded Belt

Super Blue Ribbon® Band Part Numbers

Part Number Example: **RB1000-3** =

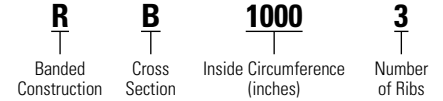

Part Number	Legacy Part Number	Outside Circumference (inches)	Outside Circumference (mm)	Weight per Rib (lbs.)
RB – Banded B Section Recommended Pulleys: Conventional – QD, Taper Bushed, or MST (A-B)				
RB35	RBP35	39	991	0.5
RB38	RBP38	42	1067	0.5
RB40	RBP40	44	1118	0.6
RB41	RBP41	45	1143	0.6
RB42	RBP42	46	1168	0.6
RB43	RBP43	47	1194	0.6
RB44	RBP44	48	1219	0.7
RB46	RBP46	50	1270	0.7
RB48	RBP48	52	1321	0.7
RB49	RBP49	53	1346	0.7
RB50	RBP50	54	1372	0.7
RB51	RBP51	55	1397	0.8
RB52	RBP52	56	1422	0.8
RB53	RBP53	57	1448	0.8
RB54	RBP54	58	1473	0.8
RB55	RBP55	59	1499	0.8
RB56	RBP56	60	1524	0.8
RB57	RBP57	61	1549	0.8
RB58	RBP58	62	1575	0.8
RB59	RBP59	63	1600	0.9
RB60	RBP60	64	1626	0.9
RB61	RBP61	65	1651	0.9
RB62	RBP62	66	1676	0.9
RB63	RBP63	67	1702	0.9
RB64	RBP64	68	1727	0.9
RB65	RBP65	69	1753	0.9
RB66	RBP66	70	1778	1.0
RB67	RBP67	71	1803	1.0
RB68	RBP68	72	1829	1.0
RB70	RBP70	74	1880	1.0
RB71	RBP71	75	1905	1.0
RB72	RBP72	76	1930	1.0
RB73	RBP73	77	1956	1.1

Part Number	Legacy Part Number	Outside Circumference (inches)	Outside Circumference (mm)	Weight per Rib (lbs.)
RB – Banded B Section Recommended Pulleys: Conventional – QD, Taper Bushed, or MST (A-B)				
RB74	RBP74	78	1981	1.1
RB75	RBP75	79	2007	1.0
RB77	RBP77	81	2057	1.0
RB78	RBP78	82	2083	1.0
RB79	RBP79	83	2108	1.0
RB80	RBP80	84	2134	1.0
RB81	RBP81	85	2159	1.1
RB82	RBP82	86	2184	1.1
RB83	RBP83	87	2210	1.1
RB85	RBP85	89	2261	1.2
RB87	RBP87	91	2311	1.2
RB88	RBP88	92	2337	1.2
RB90	RBP90	94	2388	1.2
RB91	RBP91	95	2413	1.3
RB92	RBP92	96	2438	1.3
RB93	RBP93	97	2464	1.2
RB94	RBP94	98	2489	1.4
RB95	RBP95	99	2515	1.2
RB96	RBP96	100	2540	1.3
RB97	RBP97	101	2565	1.2
RB99	RBP99	103	2616	1.3
RB100	RBP100	104	2642	1.3
RB103	RBP103	107	2718	1.3
RB104	RBP104	108	2743	1.5
RB105	RBP105	109	2769	1.3
RB106	RBP106	110	2794	1.5
RB108	RBP108	112	2845	1.4
RB109	RBP109	113	2870	1.5
RB112	RBP112	116	2946	1.4
RB115	RBP115	119	3023	1.6
RB120	RBP120	124	3150	1.5
RB124	RBP124	128	3251	1.6
RB126	RBP126	130	3302	1.8

Super Blue Ribbon® Band

Banded Belt

Super Blue Ribbon® Band Part Numbers

Part Number	Legacy Part Number	Outside Circumference (inches)	Outside Circumference (mm)	Weight per Rib (lbs.)
RB – Banded B Section Recommended Pulleys: Conventional – OD, Taper Bushed, or MST (A-B)				
RB128	RBP128	132	3353	1.6
RB130	RBP130	134	3404	1.8
RB131	RBP131	135	3429	1.9
RB133	RBP133	137	3480	1.7
RB134	RBP134	138	3505	1.9
RB136	RBP136	140	3556	1.7
RB138	RBP138	142	3607	1.9
RB140	RBP140	144	3658	1.9
RB141	RBP141	145	3683	2.0
RB142	RBP142	146	3708	2.0
RB144	RBP144	148	3759	1.8
RB145	RBP145	149	3785	2.0
RB146	RBP146	150	3810	2.0
RB148	RBP148	152	3861	1.9
RB150	RBP150	154	3912	2.1
RB158	RBP158	162	4115	2.0
RB162	RBP162	166	4216	2.2
RB171.5	RBP171.5	175.5	4458	2.4
RB173	RBP173	177	4496	2.2
RB180	RBP180	184	4674	2.2
RB195	RBP195	199	5055	2.5
RB210	RBP210	214	5436	2.9
RB225	RBP225	227.5	5779	3.1
RB240	RBP240	242.5	6160	3.3
RB255	RBP255	257.5	6541	3.5
RB270	RBP270	272.5	6922	3.8
RB285	RBP285	287.5	7303	4.0
RB300	RBP300	302.5	7684	4.2
RB315	RBP315	317.5	8065	4.4

Part Number	Legacy Part Number	Outside Circumference (inches)	Outside Circumference (mm)	Weight per Rib (lbs.)
RC – Banded C Section Recommended Pulleys: Conventional – OD, Taper Bushed, or MST (C)				
RC51	RCP51	56.3	1430	1.2
RC55	RCP55	60.3	1532	1.3
RC60	RCP60	65.3	1659	1.5
RC68	RCP68	73.3	1862	1.6
RC69	RCP69	74.3	1887	1.9
RC71	RCP71	76.3	1938	1.7
RC75	RCP75	80.3	2040	1.7
RC81	RCP81	86.3	2192	1.8
RC85	RCP85	90.3	2294	1.9
RC90	RCP90	95.3	2421	2.0
RC92	RCP92	97.3	2471	2.2
RC96	RCP96	101.3	2573	2.1
RC97	RCP97	102.3	2598	2.1
RC99	RCP99	104.3	2649	2.2
RC100	RCP100	105.3	2675	2.2
RC105	RCP105	110.3	2802	2.9
RC108	RCP108	113.3	2878	2.4
RC109	RCP109	114.3	2903	2.4
RC112	RCP112	117.3	2979	2.5
RC115	RCP115	120.3	3056	2.3
RC120	RCP120	125.3	3183	2.6
RC124	RCP124	129.3	3284	2.7
RC128	RCP128	133.3	3386	2.9
RC136	RCP136	141.3	3589	3.0
RC138	RCP138	143.3	3640	3.2
RC144	RCP144	149.3	3792	3.2
RC146	RCP146	151.3	3843	3.5
RC158	RCP158	163.3	4148	3.5
RC162	RCP162	167.3	4249	3.6
RC169	RCP169	174.3	4427	4.0
RC173	RCP173	178.3	4529	3.7
RC180	RCP180	185.3	4707	4.0

Super Blue Ribbon® Band

Banded Belt

Part Number Example: **RB148-3** = **R** **B** **148** **3**
 Banded Construction Cross Section Inside Circumference (inches) Number of Ribs

Part Number	Legacy Part Number	Outside Circumference (inches)	Outside Circumference (mm)	Weight per Rib (lbs.)
RC – Banded C Section Recommended Pulleys: Conventional – QD, Taper Bushed, or MST (C)				
RC195	RCP195	200.3	5088	4.2
RC197	RCP197	202.3	5138	4.5
RC202	RCP202	207.3	5265	4.2
RC210	RCP210	215.3	5469	4.8
RC220	RCP220	225.3	5723	5.1
RC225	RCP225	228.3	5799	5.1
RC240	RCP240	243.3	6180	5.4
RC250	RCP250	253.3	6434	5.7
RC255	RCP255	258.3	6561	5.8
RC270	RCP270	273.3	6942	6.1
RC285	RCP285	288.3	7323	6.5
RC300	RCP300	303.3	7704	6.8
RC315	RCP315	318.3	8085	7.1
RC330	RCP330	333.3	8466	7.5
RC345	RCP345	348.3	8847	7.8
RC360	RCP360	363.3	9228	8.2
RC390	RCP390	393.3	9990	8.9
RC420	RCP420	423.3	10752	9.6
RD – Banded D Section Recommended Pulleys: Conventional – QD, Taper Bushed, or MST (D)				
RD120	RDP120	126.4	3211	5.2
RD128	RDP128	134.4	3414	5.4
RD144	RDP144	150.4	3820	6.2
RD158	RDP158	164.4	4176	6.7
RD162	RDP162	168.4	4277	7.0
RD173	RDP173	179.4	4557	7.4
RD180	RDP180	186.4	4735	7.7
RD195	RDP195	201.4	5116	8.4
RD210	RDP210	216.4	5497	9.0
RD225	RDP225	228.9	5814	9.5
RD240	RDP240	243.9	6195	10.2
RD255	RDP255	258.9	6576	10.8

Part Number	Legacy Part Number	Outside Circumference (inches)	Outside Circumference (mm)	Weight per Rib (lbs.)
RD – Banded D Section Recommended Pulleys: Conventional – QD, Taper Bushed, or MST (D)				
RD270	RDP270	273.9	6957	11.4
RD285	RDP285	288.9	7338	12.0
RD300	RDP300	303.9	7719	12.7
RD315	RDP315	318.9	8100	13.3
RD330	RDP330	333.9	8481	13.9
RD345	RDP345	348.9	8862	14.6
RD360	RDP360	363.9	9243	15.3
RD390	RDP390	393.9	10005	16.6
RD420	RDP420	423.8	10765	17.8
RD450	RDP450	453.8	11527	19.1
RD480	RDP480	483.8	12289	20.4
RD540	RDP540	543.8	13813	22.9
RD600	RDP600	603.8	15337	25.4
RD660	RDP660	663.8	16861	28.0



For complete part number, add number of ribs required as indicated in example above.

Aramax[®] Xtra Duty

V-Belt



Aramax[®] Xtra Duty V-Belt

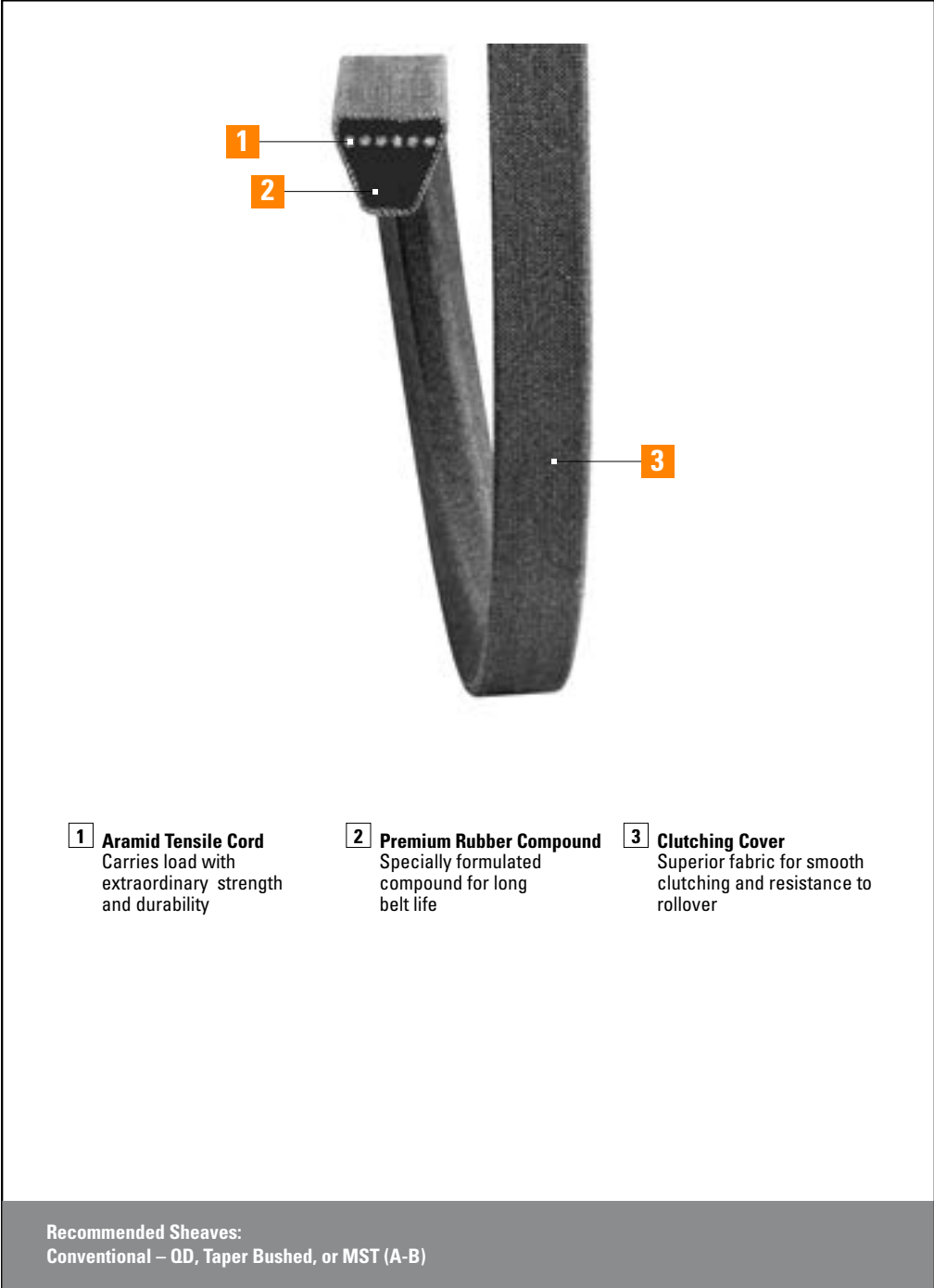

1 Aramid Tensile Cord
Carries load with extraordinary strength and durability

2 Premium Rubber Compound
Specially formulated compound for long belt life

3 Clutching Cover
Superior fabric for smooth clutching and resistance to rollover

Recommended Sheaves:
Conventional – OD, Taper Bushed, or MST (A-B)

Aramid cord is strong and durable

Premium rubber compound provides long belt life

Smooth clutching cover for shock-loaded, backside-idler drives

Superior shock resistance

Resists rollover

Oil and heat resistant

Applications:
Outdoor power equipment including
Lawnmowers
Edgers
Snow blowers
Tillers
Shredders
Splitters
& More

Synchronous Belts

V-Belts

Specialty Belts

Tools

General Information

Aramax[®] Xtra Duty

V-Belt

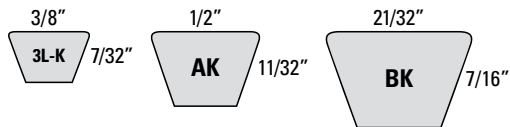

Extra duty v-belt made with Aramid cord and a smooth clutching cover. Aramax v-belts are designed for aggressive, heavy shock loaded, and backside-idler driven applications.

Performance Driven. Performance Proven.

- Aramax[®] Xtra Duty v-belts are designed for outdoor power equipment. Aramax features a brown smooth clutching cover and strong aramid cord. This high performance construction delivers more horsepower, less stretch and longer service life than v-belts with polyester cord.

Features/Advantages

- Superior clutching fabric
 - Smooth clutching
 - Increased thread count
 - Resistance to rollover
- Aramid tensile cord
 - Increased strength and durability
 - Reduced stretch
- Oil and heat resistant

Sizes

- 3L, A, B cross-sections
 - 3L sizes use the industry standard part number ending in K
 - Classical part numbers are AK, BK

Note: When Aramax belts are used as a matched set, all belts must have the same SAG number. These high modulus aramid cord belts require closer matching than standard belts in order to tension properly and work together as a set.

Part Number	Outside Circumference (inches)	Outside Circumference (mm)	Weight (lbs.)
3L Section – Recommended Sheaves: Conventional – OD, Taper Bushed, or MST (3L*)			
3L150K	15.4	391	0.1
3L160K	16.4	417	0.1
3L170K	17.4	442	0.1
3L180K	18.4	467	0.1
3L190K	19.4	493	0.1
3L200K	20.4	518	0.1
3L210K	21.4	544	0.1
3L220K	22.4	569	0.1
3L230K	23.4	594	0.1
3L240K	24.4	620	0.1
3L250K	25.4	645	0.1
3L260K	26.4	671	0.1
3L270K	27.4	696	0.1
3L280K	28.4	721	0.1
3L290K	29.4	747	0.1
3L300K	30.4	772	0.1
3L310K	31.4	798	0.1
3L320K	32.4	823	0.1
3L330K	33.4	848	0.1
3L340K	34.4	874	0.1
3L350K	35.4	899	0.1
3L360K	36.4	925	0.1
3L370K	37.4	950	0.1
3L380K	38.4	975	0.1
3L390K	39.4	1001	0.1
3L400K	40.4	1026	0.1
3L410K	41.4	1052	0.1
3L420K	42.4	1077	0.1
3L430K	43.4	1102	0.1
3L440K	44.4	1128	0.1
3L450K	45.4	1153	0.1
3L460K	46.4	1179	0.1
3L470K	47.4	1204	0.1

Aramax® Xtra Duty V-Belt Part Numbers

Part Number Example: **AK15** = **A** **K** **15**
Cross Section Aramid Cord Construction Inside Circumference (inches)

Part Number	Outside Circumference (inches)	Outside Circumference (mm)	Weight (lbs.)
3L Section – Recommended Sheaves: Conventional – QD, Taper Bushed, or MST (3L*)			
3L480K	48.4	1229	0.1
3L490K	49.4	1255	0.1
3L500K	50.4	1280	0.2
3L510K	51.4	1306	0.2
3L520K	52.4	1331	0.2
3L530K	53.4	1356	0.2
3L540K	54.4	1382	0.2
3L550K	55.4	1407	0.2
3L560K	56.4	1433	0.2
3L570K	57.4	1458	0.2
3L580K	58.6	1488	0.2
3L590K	59.4	1509	0.2
3L600K	60.4	1534	0.2
3L610K	61.4	1560	0.2
3L620K	62.4	1585	0.2
3L740K	74.4	1890	0.2
A Section – Recommended Sheaves: Conventional – QD, Taper Bushed, or MST (A-B)			
AK15	17.5	445	0.1
AK16	18.5	470	0.1
AK17	19.5	495	0.1
AK18	20.5	521	0.1
AK19	21.5	546	0.1
AK20	22.6	574	0.1
AK21	23.7	602	0.1
AK22	24.7	627	0.1
AK23	25.6	650	0.1
AK24	26.7	678	0.1
AK25	27.8	706	0.2
AK26	28.8	732	0.2
AK27	29.8	757	0.2
AK28	30.7	780	0.2
AK29	31.7	805	0.2

Part Number	Outside Circumference (inches)	Outside Circumference (mm)	Weight (lbs.)
A Section – Recommended Sheaves: Conventional – QD, Taper Bushed, or MST (A-B)			
AK30	32.7	831	0.2
AK31	33.7	856	0.2
AK32	34.7	881	0.2
AK33	35.8	909	0.2
AK34	36.8	935	0.2
AK35	37.7	958	0.2
AK36	38.7	983	0.2
AK37	39.4	1001	0.2
AK38	40.7	1034	0.2
AK39	41.7	1059	0.2
AK40	42.7	1085	0.2
AK41	43.8	1113	0.2
AK42	44.7	1135	0.2
AK43	45.8	1163	0.3
AK44	46.7	1186	0.3
AK45	47.6	1209	0.3
AK46	48.7	1237	0.3
AK47	49.8	1265	0.3
AK48	50.5	1283	0.3
AK49	51.7	1313	0.3
AK50	52.6	1336	0.3
AK51	53.7	1364	0.3
AK52	54.8	1392	0.3
AK53	55.7	1415	0.3
AK54	56.8	1443	0.3
AK55	57.8	1468	0.3
AK56	58.7	1491	0.3
AK57	59.7	1516	0.3
AK58	60.6	1539	0.3
AK59	61.7	1567	0.3
AK60	62.7	1593	0.3
AK61	63.7	1618	0.4
AK62	64.7	1643	0.4

Aramax® Xtra Duty

V-Belt

Aramax® Xtra Duty V-Belt Part Numbers

Part Number	Outside Circumference (inches)	Outside Circumference (mm)	Weight (lbs.)
A Section – Recommended Sheaves: Conventional – QD, Taper Bushed, or MST (A-B)			
AK63	65.7	1669	0.4
AK64	66.7	1694	0.4
AK65	67.7	1720	0.4
AK66	68.7	1745	0.4
AK67	69.7	1770	0.4
AK68	70.7	1796	0.4
AK69	71.7	1821	0.4
AK70	72.8	1849	0.4
AK71	73.8	1875	0.4
AK72	74.8	1900	0.4
AK73	75.6	1920	0.4
AK74	76.7	1948	0.4
AK75	77.8	1976	0.4
AK76	78.8	2002	0.4
AK77	79.8	2027	0.4
AK78	80.8	2052	0.4
AK79	81.8	2078	0.5
AK80	82.8	2103	0.5
AK81	83.8	2129	0.5
AK82	84.8	2154	0.5
AK83	85.6	2174	0.5
AK84	86.7	2202	0.5
AK85	87.8	2230	0.5
AK86	88.6	2250	0.5
AK87	89.8	2281	0.5
AK88	90.8	2306	0.5
AK89	91.8	2332	0.5
AK90	92.8	2357	0.5
AK91	93.8	2383	0.5
AK92	94.8	2408	0.5
AK93	95.8	2433	0.5
AK94	96.8	2459	0.5
AK95	97.8	2484	0.5

Part Number	Outside Circumference (inches)	Outside Circumference (mm)	Weight (lbs.)
A Section – Recommended Sheaves: Conventional – QD, Taper Bushed, or MST (A-B)			
AK96	98.8	2510	0.5
AK97	99.8	2535	0.6
AK98	100.8	2560	0.6
AK100	102.8	2611	0.6
AK101	103.7	2634	0.6
AK103	105.7	2685	0.6
AK105	107.6	2733	0.6
AK112	114.8	2916	0.6
AK115	117.5	2985	0.7
B Section – Recommended Sheaves: Conventional – QD, Taper Bushed, or MST (A-B)			
BK20	23.5	597	0.2
BK21	24.5	622	0.2
BK22	25.5	648	0.2
BK23	26.5	673	0.2
BK24	27.5	699	0.2
BK25	28.5	724	0.2
BK26	29.5	749	0.2
BK27	30.5	775	0.2
BK28	31.6	803	0.3
BK29	32.5	826	0.2
BK30	33.5	851	0.3
BK31	34.5	876	0.3
BK32	35.6	904	0.3
BK33	36.4	925	0.3
BK34	37.3	947	0.4
BK35	38.6	980	0.4
BK36	39.6	1006	0.4
BK37	40.6	1031	0.4
BK38	41.6	1057	0.4
BK39	42.6	1082	0.4
BK40	43.6	1107	0.4
BK41	44	1118	0.4

Aramax® Xtra Duty V-Belt

Part Number Example: **BK50** = **B** **K** **50**
Cross Section Aramid Cord Construction Inside Circumference (inches)

Part Number	Outside Circumference (inches)	Outside Circumference (mm)	Weight (lbs.)
B Section – Recommended Sheaves: Conventional – QD, Taper Bushed, or MST (A-B)			
BK42	45	1143	0.4
BK43	46.6	1184	0.4
BK44	47.4	1204	0.4
BK45	48.6	1234	0.5
BK46	49.5	1257	0.5
BK47	50.1	1273	0.5
BK48	51.1	1298	0.5
BK49	52.3	1328	0.5
BK50	53.3	1354	0.5
BK51	54.4	1382	0.5
BK52	55.1	1400	0.5
BK53	56.3	1430	0.5
BK54	57.1	1450	0.5
BK55	58.4	1483	0.6
BK56	59.5	1511	0.6
BK57	60.4	1534	0.6
BK58	61.4	1560	0.6
BK59	62.1	1577	0.6
BK60	63.6	1615	0.6
BK61	64.1	1628	0.6
BK62	65.2	1656	0.6
BK63	66.1	1679	0.6
BK64	67.5	1715	0.6
BK65	68.5	1740	0.7
BK66	69.4	1763	0.7
BK67	70.6	1793	0.7
BK68	71.4	1814	0.7
BK69	72.6	1844	0.7
BK70	73.3	1862	0.7
BK71	74.4	1890	0.7
BK72	75.6	1920	0.7
BK73	76.4	1941	0.7
BK74	77.6	1971	0.7

Part Number	Outside Circumference (inches)	Outside Circumference (mm)	Weight (lbs.)
B Section – Recommended Sheaves: Conventional – QD, Taper Bushed, or MST (A-B)			
BK75	78.4	1991	0.7
BK76	79.4	2017	0.8
BK77	80.6	2047	0.8
BK78	81.6	2073	0.8
BK79	82.6	2098	0.8
BK80	83.6	2123	0.8
BK81	84.6	2149	0.8
BK82	85.6	2174	0.8
BK83	86.5	2197	0.8
BK84	87.6	2225	0.8
BK85	88.6	2250	0.8
BK86	89.6	2276	0.9
BK87	90.6	2301	0.9
BK88	91.6	2327	0.9
BK89	92.6	2352	0.9
BK90	93.6	2377	0.9
BK91	94.5	2400	0.9
BK92	95.5	2426	0.9
BK93	96.6	2454	0.9
BK94	97.6	2479	0.9
BK95	98.6	2504	0.9
BK96	99.6	2530	1.0
BK97	100.6	2555	1.0
BK98	101.5	2578	1.0
BK100	103.6	2631	1.0
BK103	106.5	2705	1.1
BK105	108.5	2756	1.0
BK112	115.5	2934	1.1
BK128	131.5	3340	1.3

Double Angle

V-Belt



Double Angle V-Belt



1 Oversized Polyester Cord
High-modulus cord carries the horsepower load with minimum stretch. Specially treated to produce a long-lasting bond with the surrounding rubber assuring longer belt life. Adds belt strength and stability during peak shock loads.

2 Compression Section
Synthetic rubber compound designed to support the cords evenly and compress while bending around the sheaves.

3 Heavy Duty Cover
Stress-relieved fabric impregnated with engineered rubber compounds protects the core and assures a smooth transfer of power. Resistant to oil, heat, and environmental conditions.

Recommended Sheaves:
Conventional – OD, Taper Bushed, or MST (B, C)

Power transmitted from both sides of the belt

Special polymer provides long life

Smooth running

Resists wear, heat, ozone, and oil

Applications:

Conveyors

Mills

Cooling or

heating drums

& More

Double Angle

V-Belt

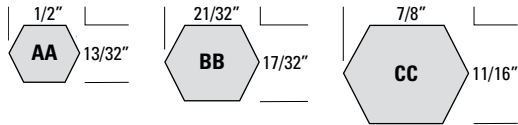

Double angle hexagonal v-belts designed for drives where power needs to be transmitted equally from both sides of the belt.



The heavy-duty cover is impregnated with oil and heat resistant rubber. The centrally located cord and special rubber compound assures long belt life and capable horsepower capacity from both sides of the belt.

Features/Advantages

- Oversized high-modulus cord carries the horsepower load with minimum stretch
 - Centrally located cord adds belt strength and stability during peak shock loads
- Heavy duty stress-relieved cover
 - Fabric is impregnated with engineered rubber compounds to protect the core and assure a smooth transfer of power
- Specially treated to produce a long-lasting bond with the surrounding rubber assuring longer belt life
 - Resistant to abrasive wear, oil, heat, and environmental conditions
 - Smooth running
- Special rubber compound provides long life
- Available in AA, BB, and CC cross sections

Double Angle V-Belt Part Numbers

Part Number	Outside Circumference (inches)	Outside Circumference (mm)	Weight (lbs.)
AA Section – Recommended Sheaves: A-B Conventional – OD, Taper Bushed, or MST (A-B)			
AA51	54.4	1382	0.4
AA55	58.6	1488	0.4
AA60	63.4	1610	0.5
AA62	65.3	1659	0.5
AA64	67.6	1717	0.5
AA66	69.3	1760	0.5
AA68	71.2	1809	0.5
AA70	73.3	1862	0.6
AA75	78.6	1996	0.6
AA78	81.3	2065	0.6
AA80	83.3	2116	0.6
AA85	88.3	2243	0.7
AA90	93.5	2375	0.7
AA92	95.3	2421	0.7
AA96	99.3	2522	0.7
AA105	108.3	2751	0.8
AA112	115.3	2929	0.9
AA120	123.3	3132	0.9
AA128	131.3	3335	1.0
AA130	133.3	3386	1.0
AA131	134.3	3411	1.0
AA136	139.3	3538	1.1
AA148	151.3	3843	1.1
AA161	164.3	4173	1.2
AA163	166.3	4224	1.3
AA184	187.3	4757	1.4
BB Section – Recommended Sheaves: A-B Conventional – OD, Taper Bushed, or MST (A-B)			
BB42	46.6	1184	0.6
BB43	47.6	1209	0.6
BB45	49.6	1260	0.6
BB51	55.2	1402	0.7

Double Angle V-Belt

Part Number Example: **AA51** = **AA** **51**
Cross Section Inside Circumference (inches)

Part Number	Outside Circumference (inches)	Outside Circumference (mm)	Weight (lbs.)
BB Section – Recommended Sheaves: Conventional – QD, Taper Bushed, or MST (B)			
BB53	57.2	1453	0.7
BB54	58.6	1488	0.7
BB55	59.6	1514	0.7
BB60	64.5	1638	0.8
BB64	68.2	1732	0.9
BB68	72.5	1842	0.9
BB71	75.2	1910	0.9
BB72	76.2	1936	1.0
BB73	77.2	1961	1.0
BB74	78.2	1986	1.0
BB75	79.2	2012	1.0
BB76	80.2	2037	1.0
BB77	81.2	2063	1.0
BB78	82.2	2088	1.0
BB80	84.2	2139	1.1
BB81	85.2	2164	1.1
BB83	87.2	2215	1.1
BB85	89.2	2266	1.1
BB89	93.2	2367	1.2
BB90	94.2	2393	1.2
BB91	95.2	2418	1.2
BB92	96.2	2444	1.2
BB93	97.2	2469	1.2
BB94	98.2	2494	1.2
BB95	99.2	2520	1.3
BB96	100.2	2545	1.3
BB97	101.2	2571	1.3
BB100	104.2	2647	1.3
BB102	106.2	2698	1.3
BB103	107.2	2723	1.4
BB105	109.2	2774	1.4
BB107	111.2	2825	1.4

Part Number	Outside Circumference (inches)	Outside Circumference (mm)	Weight (lbs.)
BB Section – Recommended Sheaves: Conventional – QD, Taper Bushed, or MST (B)			
BB108	112.2	2850	1.4
BB111	115.2	2926	1.5
BB112	116.2	2952	1.5
BB116	120.2	3053	1.5
BB117	121.2	3079	1.5
BB118	122.2	3104	1.5
BB120	124.2	3155	1.6
BB122	126.2	3206	1.6
BB123	127.2	3231	1.6
BB124	128.2	3256	1.6
BB128	132.2	3358	1.7
BB129	133.2	3383	1.7
BB130	134.2	3409	1.7
BB131	135.2	3434	1.7
BB136	140.2	3561	1.8
BB140	145.2	3688	1.8
BB144	149.2	3790	1.9
BB155	160.2	4069	2.0
BB157	162.2	4120	2.1
BB158	163.2	4145	2.1
BB160	165.2	4196	2.1
BB162	167.2	4247	2.1
BB168	173.2	4399	2.2
BB169	174.2	4425	2.2
BB170	175.2	4450	2.2
BB173	178.2	4526	2.3
BB180	185.2	4704	2.4
BB182	187.2	4755	2.4
BB190	195.2	4958	2.5
BB195	200.2	5085	2.5
BB210	214.2	5441	2.7
BB225	227.7	5784	2.9

Double Angle

V-Belt

Double Angle V-Belt Part Numbers

Part Number Example: **CC75** = **XX** **75**
Cross Section Inside Circumference (inches)

Part Number	Outside Circumference (inches)	Outside Circumference (mm)	Weight (lbs.)
BB Section – Recommended Sheaves: Conventional – QD, Taper Bushed, or MST (B)			
BB226	228.7	5809	2.9
BB228	230.7	5860	2.9
BB230	232.7	5911	3.0
BB240	242.7	6165	3.1
BB255	257.7	6546	3.3
BB267	269.7	6850	3.4
BB270	272.7	6927	3.5
BB273	275.7	7003	3.5
BB277	279.7	7104	3.6
BB278	280.7	7130	3.6
BB285	287.7	7308	3.7
BB300	302.7	7689	3.9
BB360	362.7	9213	4.7
CC Section – Recommended Sheaves: Conventional – QD, Taper Bushed, or MST (C)			
CC75	81.1	2060	1.8
CC81	87.1	2212	2.0
CC85	91.1	2314	2.1
CC90	96.1	2441	2.2
CC96	102.1	2593	2.3
CC105	111.1	2822	2.5
CC112	118.1	3000	2.7
CC119	125.1	3178	2.9
CC120	126.1	3203	2.9
CC128	134.1	3406	3.1
CC136	142.1	3609	3.2
CC140	146.1	3711	3.3
CC144	150.1	3813	3.4
CC148	154.9	3935	3.5
CC150	156.9	3985	3.6
CC158	164.1	4168	3.8
CC162	168.1	4270	3.8

Part Number	Outside Circumference (inches)	Outside Circumference (mm)	Weight (lbs.)
CC Section – Recommended Sheaves: Conventional – QD, Taper Bushed, or MST (C)			
CC173	179.1	4549	4.1
CC176	182.1	4625	4.2
CC180	186.1	4727	4.3
CC195	201.1	5108	4.6
CC210	216.4	5497	5.0
CC225	229.1	5819	5.3
CC240	244.4	6208	5.6
CC255	259.4	6589	6.0
CC270	274.4	6970	6.3
CC300	304.4	7732	7.0
CC330	334.1	8486	7.7
CC360	364.4	9256	8.4
CC390	394.4	10018	9.1
CC420	424.4	10780	9.8

Durapower® II FHP V-Belt

Light Duty Fractional Horsepower Belt

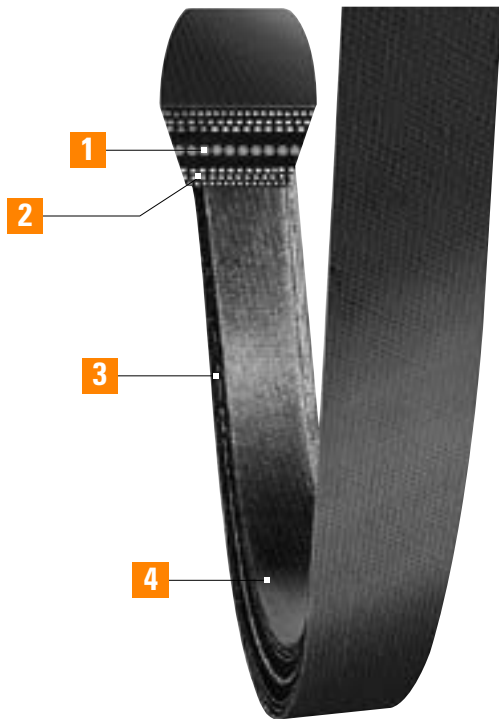

1 Oversized Polyester Cord
High-modulus cord carries the horsepower load with minimum stretch. Specially treated to produce a long-lasting bond with the surrounding rubber assuring longer belt life. The central position contributes to greater flexibility and stability.

2 Premium Fabric
Multiple fabric plies, top and bottom, relieve stress on the load-carrying center cord for added flexibility.

3 Raw Edge Sidewalls
Produce a higher coefficient of friction and minimizes slippage. The gripping power provides higher energy efficiency and reduces vibration for extended component life.

4 EPDM Construction
Offers superior flex and load carrying capacity at high and low temperatures. EPDM is durable, static conductive and resistant to heat, hardening and glazing.

Recommended Pulleys:
FHP – Bore-to-Size, MST (AK, BK)

Unique CNA design

Flexible

Stable

Static conductive

Energy efficient

Resistant to hardening and glazing

Broad operating temperature range

Low maintenance and downtime

Applications:

Fractional horsepower motors

HVAC

Fans

& More

Durapower® II FHP V-Belt

Light Duty Fractional Horsepower Belt

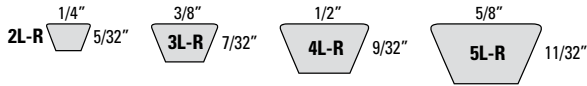

Light duty v-belt designed for fractional horsepower (FHP) applications is made of Ethylene Propylene Diene Monomer (EPDM). Durapower II v-belts combine the advantages of EPDM, raw edge technology, and Central Neutral Axis (CNA) construction for superior performance and efficiency.

FHP raw edge v-belt made of EPDM (Ethylene Propylene Diene Monomer) and CNA (Central Neutral Axis) cord placement creates a flexible, stable and efficient v-belt. Specially formulated fiber-loaded EPDM rubber compounds and high-modulus polyester cord offer greater strength, longer life, better heat dissipation and higher efficiencies than best-in-class wrapped fhp v-belts.

EPDM is durable, heat resistant, static conductive and resistant to hardening and glazing. The unique CNA cord placement positions the strength of the belt lower on the pulleys to maintain stability and prevent roll-over. The raw edge construction results in more efficient power transmission and reduced energy loss. Multiple fabric plies, top and bottom, relieve stress on the load-carrying center cord for added flexibility.

- High performance alternative to wrapped v-belts
- Unique design for long belt life
- Grip with controlled slippage
- Low maintenance and downtime
- More energy efficient than wrapped v-belts
- Static conductive
- Resistant to hardening and glazing
- Broad operating temperature range (-50°F to +250°F)

Note: Aramax® Xtra Duty v-belt with Aramid cord is also available in a 3L-K cross section. See page: 172.

Belt Life Comparison

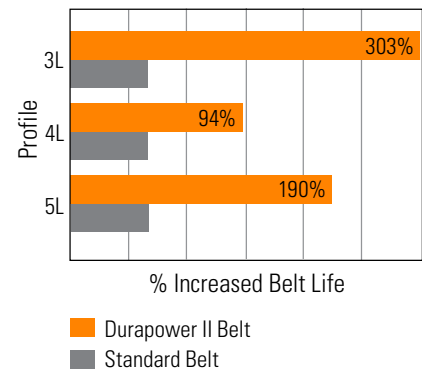

Durapower® II FHP V-Belt

Light Duty Fractional Horsepower Belt

Durapower® II FHP Belt Part Numbers

Part Number Example: **4L200R** = **4L** **200** **R**
Cross Section Outside Circumference (inches in tenths: 20.0) Raw Edge Construction

Part Number	Outside Circumference (inches)	Outside Circumference (mm)	Weight (lbs.)
2L Section Recommended Pulleys: FHP – Bore-to-Size, MST (AK, BK)			
2L110R	11	279	0.1
2L120R	12	305	0.1
2L140R	14	356	0.1
2L150R	15	381	0.1
2L160R	16	406	0.1
2L200R	20	508	0.1
2L230R	23	584	0.1
2L250R	25	635	0.1
2L360R	36	914	0.1
3L Section Recommended Pulleys: FHP – Bore-to-Size, MST (AK, BK)			
3L150†	15	381	0.1
3L160†	16	406	0.1
3L170†	17	432	0.1
3L180†	18	457	0.1
3L190R	18.7	475	0.1
3L200R	20	508	0.1
3L210R	20.9	531	0.1
3L220R	21.9	556	0.1
3L230R	22.8	579	0.1
3L240R	23.8	605	0.1
3L250R	24.7	627	0.1
3L260R	26	660	0.1
3L270R	26.9	683	0.1
3L280R	27.9	709	0.1
3L290R	28.8	732	0.1
3L300R	29.8	757	0.1
3L310R	31	787	0.1
3L320R	32	813	0.1
3L330R	32.9	836	0.1
3L340R	33.9	861	0.1
3L350R	34.8	884	0.1
3L360R	35.8	909	0.1

Part Number	Outside Circumference (inches)	Outside Circumference (mm)	Weight (lbs.)
3L Section Recommended Pulleys: FHP – Bore-to-Size, MST (AK, BK)			
3L370R	36.9	937	0.1
3L380R	38	965	0.1
3L390R	38.9	988	0.1
3L400R	39.9	1014	0.1
3L410R	40.8	1036	0.1
3L420R	42.1	1069	0.1
3L430R	43	1092	0.1
3L440R	44	1118	0.2
3L450R	44.9	1141	0.2
3L460R	45.9	1166	0.2
3L470R	46.8	1189	0.2
3L480R	47.8	1214	0.2
3L490R	49	1245	0.2
3L500R	50	1270	0.2
3L510R	50.9	1293	0.2
3L520R	51.9	1318	0.2
3L530R	52.8	1341	0.2
3L540R	53.7	1364	0.2
3L550R	54.7	1389	0.2
3L560R	56	1422	0.2
3L570R	56.9	1445	0.2
3L580R	57.8	1468	0.2
3L590R	58.8	1494	0.2
3L600R	59.7	1516	0.2
3L610R	61	1549	0.2
3L620R	61.9	1572	0.2
3L630R	62.9	1598	0.2
3L670R	67	1702	0.2
3L690R	68.9	1750	0.2
3L710R	70.8	1798	0.2
3L740R	73.9	1877	0.3
3L750R	74.9	1903	0.3

† Available in wrapped construction only.

Durapower® II FHP V-Belt

Light Duty Fractional Horsepower Belt

Durapower® II FHP Belt Part Numbers

Part Number	Outside Circumference (inches)	Outside Circumference (mm)	Weight (lbs.)
4L Section Recommended Pulleys: FHP – Bore-to-Size, MST (AK, BK)			
4L160†	16	406	0.1
4L170†	17	432	0.1
4L180†	18	457	0.1
4L190R	18.9	480	0.1
4L200R	19.9	506	0.1
4L210R	20.8	528	0.1
4L220R	21.7	551	0.1
4L230R	23	584	0.1
4L240R	23.9	607	0.1
4L250R	24.8	630	0.1
4L260R	25.8	655	0.1
4L270R	27	686	0.2
4L280R	28	711	0.2
4L290R	28.9	734	0.2
4L300R	29.9	760	0.2
4L305R	30.2	767	0.2
4L310R	30.8	782	0.2
4L315R	31.1	790	0.2
4L320R	31.8	808	0.2
4L330R	33	838	0.2
4L340R	33.9	861	0.2
4L350R	34.9	887	0.2
4L360R	35.8	909	0.2
4L370R	36.8	935	0.2
4L380R	37.7	958	0.2
4L390R	38.9	988	0.2
4L400R	39.9	1014	0.2
4L410R	40.8	1036	0.2
4L420R	41.8	1062	0.2
4L430R	42.7	1085	0.2
4L440R	43.7	1110	0.3
4L450R	44.9	1141	0.3
4L460R	45.9	1166	0.3

Part Number	Outside Circumference (inches)	Outside Circumference (mm)	Weight (lbs.)
4L Section Recommended Pulleys: FHP – Bore-to-Size, MST (AK, BK)			
4L470R	46.9	1191	0.3
4L480R	47.7	1212	0.3
4L490R	48.7	1237	0.3
4L500R	49.9	1268	0.3
4L510R	50.8	1290	0.3
4L515R	51.4	1306	0.3
4L520R	51.7	1313	0.3
4L530R	52.7	1339	0.3
4L540R	53.7	1364	0.3
4L550R	54.9	1395	0.3
4L560R	55.8	1417	0.3
4L570R	56.8	1443	0.3
4L580R	57.8	1468	0.3
4L590R	59	1499	0.3
4L600R	59.9	1522	0.3
4L610R	60.9	1547	0.4
4L620R	61.7	1567	0.4
4L630R	63	1600	0.4
4L640R	63.9	1623	0.4
4L650R	64.8	1646	0.4
4L660R	65.7	1669	0.4
4L670R	66.7	1694	0.4
4L680R	67.7	1720	0.4
4L690R	68.6	1742	0.4
4L700R	69.7	1770	0.4
4L710R	70.9	1801	0.4
4L720R	71.8	1824	0.4
4L730R	72.8	1849	0.4
4L740R	73.8	1875	0.4
4L750R	74.7	1897	0.4
4L760R	76	1930	0.4
4L770R	77	1956	0.4
4L780R	77.9	1979	0.4

† Available in wrapped construction only.

Durapower® II FHP V-Belt

Light Duty Fractional Horsepower Belt

Part Number Example: **5L460R** = **5L** **460** **R**
Cross Section Outside Circumference (inches in tenths: 46.0) Raw Edge Construction

Part Number	Outside Circumference (inches)	Outside Circumference (mm)	Weight (lbs.)
4L Section Recommended Pulleys: FHP – Bore-to-Size, MST (AK, BK)			
4L790R	78.8	2002	0.5
4L800R	79.8	2027	0.5
4L810R	80.9	2055	0.5
4L820R	81.8	2078	0.5
4L830R	82.8	2103	0.5
4L840R	83.7	2126	0.5
4L850R	84.7	2151	0.5
5L Section Recommended Pulleys: FHP – Bore-to-Size, MST (AK, BK)			
5L230R	23	584	0.2
5L240R	23.9	607	0.2
5L250R	24.9	633	0.2
5L260R	26.1	663	0.2
5L270R	27.1	688	0.2
5L280R	28.1	714	0.2
5L290R	29	737	0.3
5L300R	29.9	760	0.3
5L310R	31.2	793	0.3
5L320R	31.8	808	0.3
5L330R	33.1	841	0.3
5L340R	33.7	856	0.3
5L350R	35	889	0.3
5L360R	35.9	912	0.3
5L370R	36.9	937	0.3
5L380R	37.8	960	0.3
5L390R	38.7	983	0.3
5L400R	40	1016	0.4
5L410R	41	1041	0.4
5L420R	41.9	1064	0.4
5L430R	42.8	1087	0.4
5L440R	44.1	1120	0.4
5L450R	45	1143	0.4
5L460R	46	1168	0.4

Part Number	Outside Circumference (inches)	Outside Circumference (mm)	Weight (lbs.)
5L Section Recommended Pulleys: FHP – Bore-to-Size, MST (AK, BK)			
5L470R	47.3	1201	0.4
5L480R	48.2	1224	0.4
5L490R	49.1	1247	0.4
5L500R	50.1	1273	0.4
5L510R	51	1295	0.4
5L520R	52	1321	0.5
5L530R	52.9	1344	0.5
5L540R	53.9	1369	0.5
5L550R	55.1	1400	0.5
5L560R	55.8	1417	0.5
5L570R	57	1448	0.5
5L580R	58	1473	0.5
5L590R	58.9	1496	0.5
5L600R	59.8	1519	0.5
5L610R	60.8	1544	0.5
5L620R	62.1	1577	0.5
5L630R	63	1600	0.6
5L640R	63.9	1623	0.6
5L650R	64.9	1649	0.6
5L660R	66.1	1679	0.6
5L670R	66.8	1697	0.6
5L680R	68	1727	0.6
5L690R	69	1753	0.6
5L700R	69.9	1776	0.6
5L710R	70.9	1801	0.6
5L720R	72.1	1831	0.6
5L730R	73.1	1857	0.6
5L740R	74	1880	0.6
5L750R	75	1905	0.6
5L760R	75.9	1928	0.7
5L770R	76.9	1953	0.7
5L780R	78.1	1984	0.7
5L790R	79.1	2009	0.7

Durapower® II FHP V-Belt

Light Duty Fractional Horsepower Belt

Durapower® II FHP Belt Part Numbers

Part Number	Outside Circumference (inches)	Outside Circumference (mm)	Weight (lbs.)
5L Section Recommended Pulleys: FHP – Bore-to-Size, MST (AK, BK)			
5L800R	80	2032	0.7
5L810R	81	2057	0.7
5L820R	81.9	2080	0.7
5L830R	82.8	2103	0.7
5L840R	84.1	2136	0.7
5L850R	85	2159	0.8



Variable Speed Cog-Belt®

V-Belt



1

2

3

4

1 Oversized Cord
High-modulus cord carries the horsepower load with minimum stretch. Specially treated to produce a long-lasting bond with the surrounding rubber assuring longer belt life. Adds belt strength and stability during peak shock loads. Some belts are made with polyester cord, others with Aramid cord.

2 EPDM Construction
Offers superior flex and load carrying capacity at high and low temperatures. EPDM is durable, static conductive and resistant to heat, hardening and glazing.

3 Precision Molded Cogs
Improves flexibility and reduces stress that enables the belt to bend more easily around the pulley. It runs cooler – less heat equals longer belt life.

4 Raw Edge Sidewalls
Produce a higher coefficient of friction and minimizes slippage. The gripping power provides higher energy efficiency and reduces vibration for extended component life.

- Smooth running
- Oil and heat resistant
- Wide selection of sizes
- Resists fatigue and shock load
- Excellent belt stability
- Strong but flexible for long belt life
- Carries high HP loads with minimum stretch

Applications:
Industrial variable speed drives & More

Synchronous Belts

V-Belts

Specialty Belts

Tools

General Information

Variable Speed Cog-Belt®

V-Belt

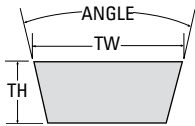

Variable speed cog-belts are designed for use with industrial variable speed pulleys to gain a wide range of driven speeds.



Timken Belts is a leader in variable speed belt technology. Belts are made of Ethylene Propylene Diene Monomer (EPDM) that is durable and resistant to oil, heat, hardening and glazing. EPDM also has a superior flex and load carrying capacity with a broad operating temperature range of -50°F to +250°F.

The Variable Speed Cog-Belt has been engineered to the same high standards that Timken Belts uses to produce belts for original equipment manufacturers (OEMs).

- Smooth running
- Long belt life
- Raw edge sidewalls improve gripping action
- EPDM provides superior resistance to aging caused by wear, oil, heat, grease and other harmful environmental factors
- Static dissipating
- Wide selection of sizes

Variable Speed Cog-Belt® Part Numbers

Part Number	Outside Circumference (inches)	Outside Circumference (mm)	Weight (lbs.)
1228V255	26.1	663	0.6
1422V240	24.6	625	1.0
1422V270	27.6	701	0.9
1422V290	29.6	752	0.9
1422V300	30.6	777	0.8
1422V330	33.6	853	0.9
1422V340	34.6	879	0.3
1422V360	36.6	930	0.3
1422V400	40.6	1031	0.8
1422V420	42.6	1082	0.7
1422V440	44.6	1133	0.6
1422V460	46.6	1184	0.6
1422V466	47.2	1199	0.6
1422V470	47.6	1209	0.6
1422V480	48.6	1234	0.6
1422V540	54.6	1387	0.7
1422V600	60.6	1539	0.8
1422V660	66.6	1692	0.8
1422V720	72.6	1844	0.9
1422V780	78.6	1996	1.0
1430V215	21.9	556	0.3
1626V262	26.8	681	0.4
1626V293	29.9	760	0.5
1626V304	31	787	0.5
1626V330	33.6	853	0.5
1626V339	34.5	876	0.6
1626V384	39	991	0.6
1626V428	43.4	1102	0.7
1626V440	44.6	1133	0.7
1626V513	51.9	1318	0.8
1626V517	52.3	1328	0.8
1626V604	61	1549	1.0
1626V700	70.6	1793	1.1

Variable Speed Cog-Belt®

V-Belt

Part Number Example: **1228V255** = **12** **28** **V** **40**
Top Width (inches in sixteenths: 12/16") Pulley Angle Variable Speed Pitch Length (inches in tenths: 25.5")

Part Number	Outside Circumference (inches)	Outside Circumference (mm)	Weight (lbs.)
1628V210	21.3	541	0.2
1628V315	32	813	0.5
1632V210	21.5	546	0.2
1632V220	22.5	572	0.3
1822V328	33.4	848	0.6
1828V368	37.5	953	0.8
1922V1146	115.2	2926	1.4
1922V256	26.2	666	0.5
1922V277	28.3	719	0.5
1922V282	28.8	732	0.5
1922V298	30.4	772	0.6
1922V302	30.8	782	0.6
1922V321	32.7	831	0.6
1922V332	33.8	859	0.6
1922V338	34.4	874	0.6
1922V363	36.9	937	0.7
1922V381	38.7	983	0.7
1922V386	39.2	996	0.7
1922V403	40.9	1039	0.8
1922V417	42.3	1074	0.8
1922V426	43.2	1097	0.8
1922V443	44.9	1141	0.8
1922V454	46	1168	0.9
1922V460	46.6	1184	0.9
1922V484	49	1245	0.9
1922V526	53.2	1351	1.0
1922V544	55	1397	1.0
1922V604	61	1549	1.1
1922V630	63.6	1615	1.2
1922V646	65.2	1656	1.2
1922V666	67.2	1707	1.3
1922V686	69.2	1758	1.3
1922V706	71.2	1809	1.3

Part Number	Outside Circumference (inches)	Outside Circumference (mm)	Weight (lbs.)
1922V721	72.7	1847	1.4
1922V726	73.2	1859	1.4
1922V751	75.7	1923	1.4
1922V756	76.2	1936	1.4
1922V806	81.2	2063	1.5
1922V846	85.2	2164	1.6
1922V891	89.7	2278	1.7
1922V966	97.2	2469	1.8
1926V250	25.9	658	0.4
1926V275	28.3	719	0.4
1926V390	39.6	1006	0.6
1930V1091	109.9	2792	2.7
1930V1191	119.9	3046	2.9
1930V366	37.4	950	0.9
1930V375	38.3	973	0.9
1930V400	40.8	1036	1.0
1930V425	43.3	1100	1.1
1930V431	43.9	1115	1.1
1930V491	49.9	1268	1.2
1930V530	53.8	1367	1.3
1930V541	54.9	1395	1.3
1930V560	56.6	1438	1.6
1930V591	59.9	1522	1.5
1930V600	60.8	1544	1.5
1930V641	64.9	1649	1.6
1930V691	69.9	1776	1.7
1930V750	75.8	1925	1.9
1930V791	79.9	2030	1.9
1930V891	89.9	2284	2.2
1930V991	99.9	2538	2.4
2126V309	31.4	798	0.7
2126V468	47.4	1204	1.0
2226V307	31.3	795	0.8

Variable Speed Cog-Belt®

V-Belt

Variable Speed Cog-Belt®

Part Numbers

Part Number	Outside Circumference (inches)	Outside Circumference (mm)	Weight (lbs.)
2230V266	27.5	699	0.6
2230V273	28.5	724	0.7
2230V275	28.5	724	0.6
2230V326	33.6	853	0.7
2230V375	38.6	980	0.6
2322V1001	100.8	2560	3.0
2322V1061	106.8	2713	3.2
2322V329	33.6	853	0.7
2322V347	35.4	899	1.1
2322V364	37.1	942	1.1
2322V384	39.1	993	1.2
2322V396	40.3	1024	1.2
2322V421	42.8	1087	1.3
2322V434	44.1	1120	1.0
2322V441	44.8	1138	1.3
2322V481	48.8	1240	1.5
2322V486	49.3	1252	1.5
2322V521	52.8	1341	1.6
2322V541	54.8	1392	1.6
2322V601	60.8	1544	1.8
2322V621	62.8	1595	1.9
2322V661	66.8	1697	2.0
2322V681	68.8	1748	2.0
2322V701	70.8	1798	2.1
2322V721	72.8	1849	2.2
2322V801	80.8	2052	2.4
2322V826	83.3	2116	2.5
2322V846	85.3	2167	2.5
2322V886	89.3	2268	2.7
2322V921	92.8	2357	2.8
2326V310	31.5	800	0.7
2326V359	36.6	930	1.1
2330V273	28	711	0.6

Part Number	Outside Circumference (inches)	Outside Circumference (mm)	Weight (lbs.)
2426V343	35	889	1.0
2428V707	71.4	1814	2.2
2430V297	30.4	772	0.9
2430V345	35.2	894	1.0
2436V331	33.8	859	0.9
2526V314	32	813	0.9
2530V1090	110.1	2797	4.8
2530V1190	120.1	3051	5.2
2530V1290	130.1	3305	5.6
2530V1490	150.1	3813	6.5
2530V1690	170.1	4321	7.3
2530V309	31.6	803	1.0
2530V470	48.1	1222	2.1
2530V490	50.1	1273	2.2
2530V530	54.1	1374	2.3
2530V550	56.1	1425	2.4
2530V575	58.6	1488	2.5
2530V595	60.6	1539	2.6
2530V610	62.1	1577	2.7
2530V630	64.1	1628	2.8
2530V660	67.1	1704	2.9
2530V670	68.1	1730	2.9
2530V690	70.1	1781	3.0
2530V700	71.1	1806	3.1
2530V730	74.1	1882	3.2
2530V740	75.1	1908	3.2
2530V750	76.1	1933	3.3
2530V790	80.1	2035	3.5
2530V840	85.1	2162	3.7
2530V890	89.9	2284	3.9
2530V934	94.5	2400	4.1
2530V990	100.1	2543	4.3
2626V369	37.6	955	1.2

Variable Speed Cog-Belt®

V-Belt

Part Number Example: **2530V309** =

25 **30** **V** **309**
 Top Width Pulley Variable Pitch Length
 (inches in sixteenths: 25/16") Angle Speed (inches in tenths: 30.9")

Part Number	Outside Circumference (inches)	Outside Circumference (mm)	Weight (lbs.)
2626V388	39.6	1006	1.3
2630V345	35.6	904	1.0
2636V332	33.9	861	1.0
2822V778	78.6	1996	2.8
2826V412	42	1067	1.6
2826V452	46	1168	1.6
2830V337	34.5	876	1.1
2830V363	37	940	1.2
2830V366	37.2	945	1.2
2830V367	37.5	953	1.4
2830V393	40	1016	1.3
2830V396	40.5	1029	1.3
2830V422	42.9	1090	1.4
2830V428	43.4	1102	1.4
2836V343	35.1	892	1.2
2836V361	36.9	937	1.3
2836V380	38.8	986	1.3
2926V1006	101.4	2576	4.3
2926V366	37.4	950	1.6
2926V400	40.8	1036	1.7
2926V426	43.4	1102	1.9
2926V471	47.9	1217	2.1
2926V477	48.5	1232	2.1
2926V486	49.6	1260	2.1
2926V491	50.1	1273	2.1
2926V521	52.9	1344	2.3
2926V546	56.1	1425	2.4
2926V574	58.2	1478	2.5
2926V586	59.4	1509	2.5
2926V606	61.4	1560	2.6
2926V616	62.6	1590	2.7
2926V636	64.4	1636	2.8
2926V646	65.4	1661	2.8

Part Number	Outside Circumference (inches)	Outside Circumference (mm)	Weight (lbs.)
2926V666	67.4	1712	2.9
2926V686	69.6	1768	3.0
2926V706	71.4	1814	3.1
2926V726	73.4	1864	3.1
2926V776	78.4	1991	3.4
2926V786	79.4	2017	3.4
2926V834	84.2	2139	3.6
2926V856	86.4	2195	3.7
2926V891	89.9	2284	3.8
2926V906	91.4	2322	3.9
2926V966	97.4	2474	4.2
3226V1023	103.1	2619	4.8
3226V1083	109.1	2771	5.1
3226V392	39.8	1011	1.9
3226V395	40.3	1024	1.9
3226V400	40.8	1036	1.9
3226V439	44.7	1135	2.1
3226V450	46	1168	2.6
3226V465	47.3	1201	2.2
3226V505	51.3	1303	2.4
3226V514	52.2	1326	2.4
3226V545	55.3	1405	2.6
3226V585	59.3	1506	2.7
3226V603	61.1	1552	2.8
3226V663	67.1	1704	3.1
3226V723	73.1	1857	3.4
3226V783	79.1	2009	3.7
3226V843	85.1	2162	3.9
3226V903	91.1	2314	4.2
3226V963	97.1	2466	4.5
3230HV1060	107.1	2720	6.0
3230HV528	53.9	1369	3.0
3230HV553	56.4	1433	3.1

Variable Speed Cog-Belt®

V-Belt

Variable Speed Cog-Belt® Part Numbers

Part Number	Outside Circumference (inches)	Outside Circumference (mm)	Weight (lbs.)
3230HV570	58.1	1476	3.2
3230HV585	59.6	1514	3.3
3230HV603	61.4	1560	3.4
3230HV613	62.4	1585	3.5
3230HV620	63.1	1603	3.5
3230HV626	63.7	1618	3.5
3230HV644	65.5	1664	3.7
3230HV656	66.7	1694	3.7
3230HV670	68.1	1730	3.8
3230HV685	69.6	1768	3.9
3230HV702	71.3	1811	4.0
3230HV723	73.4	1864	4.1
3230HV821	83.2	2113	4.6
3230HV856	86.7	2202	4.8
3230HV931	94.2	2393	5.3
3230HV960	97.1	2466	5.4
3230V419	43.4	1102	1.6
3230V528	53.8	1367	1.6
3230V553	56.3	1430	2.2
3230V560	57	1448	2.1
3230V710	72	1829	2.7
3236HV389	40.2	1021	2.1
3236V342	35.2	894	1.3
3236V369	37.9	963	1.7
3236V432	44	1118	1.8
3326V478	48.7	1237	2.5
3432V450	45.6	1158	2.0
3432V456	46.4	1179	2.1
3432V480	48.6	1234	2.2
3432V484	49.2	1250	2.2
3432V534	54.2	1377	2.4
3636V479	48.7	1237	2.5
3726V558	56.7	1440	3.1

Part Number	Outside Circumference (inches)	Outside Circumference (mm)	Weight (lbs.)
3826V459	46.9	1191	2.1
3826V465	47.5	1207	2.7
3830V510	52	1321	3.0
3830V580	59	1499	3.5
3830V587	59.7	1516	3.3
3836V418	42.8	1087	2.3
3836V426	43.6	1107	2.4
3836V654	66.4	1687	3.6
3836V734	74.4	1890	4.1
3836V794	80.4	2042	4.4
4030V538	54.8	1392	3.2
4036V541	55.2	1402	3.6
4036V574	58.4	1483	3.5
4230V556	56.4	1433	3.5
4230V605	61.5	1562	3.8
4230V653	66.3	1684	4.1
4430V1030	104.1	2644	8.3
4430V1090	110.1	2797	8.8
4430V1150	116.1	2949	9.2
4430V1320	133.1	3381	10.6
4430V1410	142.1	3609	8.9
4430V1460	147.1	3736	11.7
4430V1610	162.1	4117	12.9
4430V510	52.1	1323	4.1
4430V530	54.1	1374	4.3
4430V548	55.9	1420	4.4
4430V555	56.6	1438	4.5
4430V570	58.1	1476	4.6
4430V578	58.9	1496	4.7
4430V600	61.1	1552	4.9
4430V610	62.1	1577	4.9
4430V630	64.1	1628	5.1
4430V660	67.1	1704	5.3

Variable Speed Cog-Belt®

V-Belt

Part Number Example: **3836V734** =

38 **36** **V** **734**
Top Width Pulley Variable Pitch Length
(inches in sixteenths: 38/16") Angle Speed (inches in tenths: 73.4")

Part Number	Outside Circumference (inches)	Outside Circumference (mm)	Weight (lbs.)
4430V670	68.1	1730	5.4
4430V690	70.1	1781	5.6
4430V700	71.1	1806	5.6
4430V718	72.9	1852	5.8
4430V730	74.1	1882	5.9
4430V740	75.1	1908	6.0
4430V760	77.1	1958	6.1
4430V767	78.1	1984	8.1
4430V790	80.1	2035	6.4
4430V800	81.1	2060	0.7
4430V850	86.1	2187	6.8
4430V910	92.1	2339	7.3
4430V970	98.1	2492	7.8
4436V329	34	864	1.8
4436V525	53.6	1361	4.0
4436V551	56.2	1428	4.2
4436V561	57.2	1453	4.1
4436V576	58.7	1491	4.6
4436V646	65.7	1669	4.9
4626V596	60.9	1547	5.7
4630V650	66.3	1684	6.1
4630V663	67.4	1712	6.9
4630V683	69.2	1758	6.4
4630V733	74.3	1887	7.5
4636V613	62.6	1590	5.6
4830V602	61.5	1562	5.9
4830V653	66.4	1687	6.5
4830V699	71.2	1809	6.9
4830V750	76.3	1938	7.5
4836V1000	101.1	2568	8.4
4836V1060	107.1	2720	8.8
4836V1120	113.1	2873	9.3
4836V1180	119.1	3025	10.4

Part Number	Outside Circumference (inches)	Outside Circumference (mm)	Weight (lbs.)
4836V1250	126.1	3203	10.4
4836V588	59.9	1522	4.5
4836V608	61.9	1572	5.3
4836V618	62.9	1598	4.8
4836V642	65.3	1659	5.6
4836V655	66.6	1692	5.5
4836V670	68.1	1730	5.9
4836V710	72.1	1831	6.2
4836V750	76.1	1933	6.3
4836V800	81.1	2060	7.0
4836V850	86.1	2187	7.5
4836V900	91.1	2314	7.5
4836V950	96.1	2441	7.9
5130V732	74.6	1895	8.6
5130V787	80.1	2035	6.7
5130V799	81.2	2063	9.2
5228V930	93.8	2383	11.0
5230V734	74.6	1895	8.7
5230V867	88	2235	10.3
5430V783	79.9	2030	10.8
5636V750	76.4	1941	9.4
5636V774	78.8	2002	9.7
5636V845	85.9	2182	1.1
5830V756	77	1956	10.0
6136V751	76.4	1941	10.5
6136V756	76.9	1953	10.6

Vee-Rib™

V-Belt



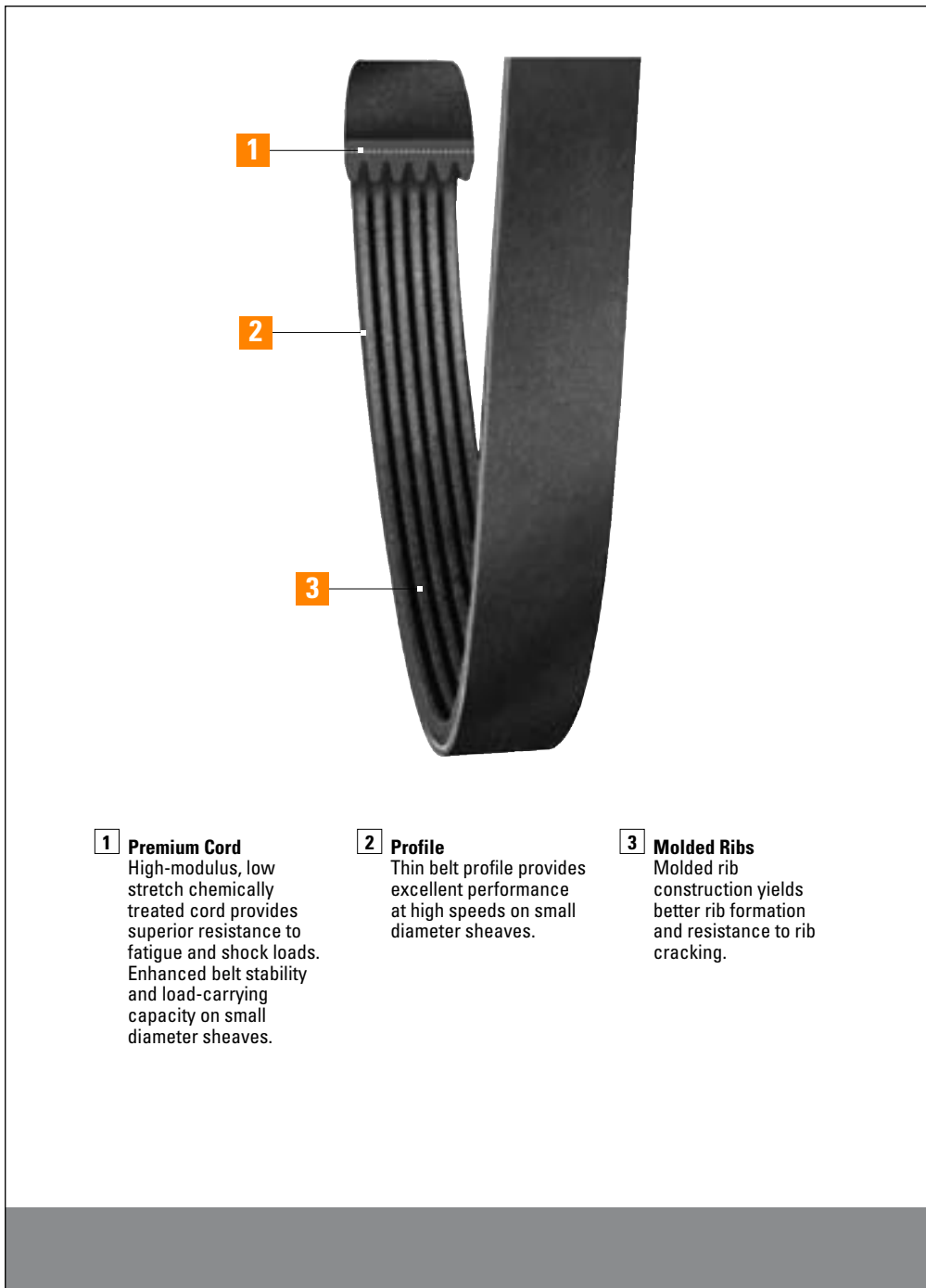

1 Premium Cord
High-modulus, low stretch chemically treated cord provides superior resistance to fatigue and shock loads. Enhanced belt stability and load-carrying capacity on small diameter sheaves.

2 Profile
Thin belt profile provides excellent performance at high speeds on small diameter sheaves.

3 Molded Ribs
Molded rib construction yields better rib formation and resistance to rib cracking.

Outstanding performance on industrial v-ribbed drives

Vibration-free

Heat resistant

Flexible

High horsepower

Abrasion resistant

Applications:

Industrial dryers

Fitness equipment

Machine tools

High speed blowers

& More

Vee-Rib™ V-Belt

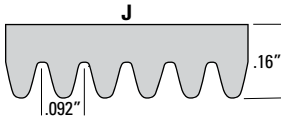

Vee-Rib belts are designed for high speed drives where conventional v-belts cannot operate providing smooth, vibration-free performance.



Vee-Rib belts offer outstanding performance on industrial high-speed drives and high drive ratio applications. Vee-Rib belts provide smooth, vibration-free performance in a compact drive.

High modulus, low stretch polyester cord provides superior resistance to fatigue and shock loads with enhanced load-carrying capacity on small diameter pulleys. The special rib design enhances belt flexibility and resists cracking. Vee-Rib belts are resistant to oil, heat and abrasion for long belt life.

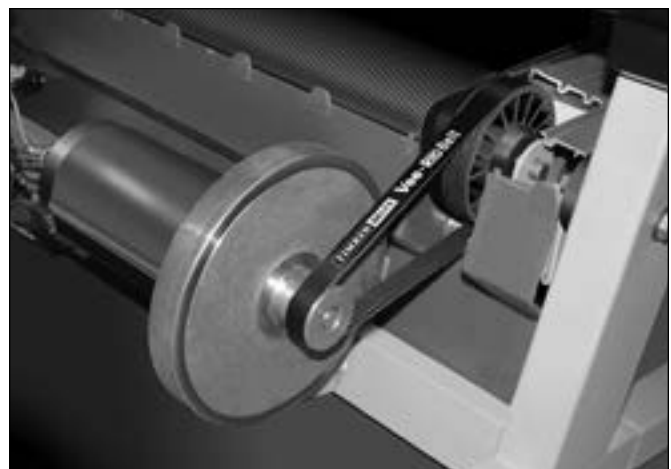

Vee-Rib™ V-Belt Part Numbers

Part Number Example: **140J2** = **140** Effective Length (inches in tenths: 14.0") | **J** Cross Section | **2** Number of Ribs

Part Number	Outside Circumference (inches)	Outside Circumference (mm)	Weight (lbs.)
140J2	14.5	368	0.01
140J3	14.5	368	0.02
140J4	14.5	368	0.03
140J5	14.5	368	0.03
140J6	14.5	368	0.04
140J7	14.5	368	0.05
140J8	14.5	368	0.05
140J10	14.5	368	0.07
140J16	14.5	368	0.11
140J24	14.5	368	0.16
140J30	14.5	368	0.20
150J2	15.5	394	0.02
150J3	15.5	394	0.02
150J4	15.5	394	0.03
150J5	15.5	394	0.04
150J6	15.5	394	0.04
150J8	15.5	394	0.06
150J10	15.5	394	0.07
150J16	15.5	394	0.12
150J24	15.5	394	0.18
150J30	15.5	394	0.22
160J2	16.5	419	0.02
160J3	16.5	419	0.02
160J4	16.5	419	0.03
160J5	16.5	419	0.04
160J6	16.5	419	0.05
160J8	16.5	419	0.06
160J10	16.5	419	0.08
160J15	16.5	419	0.20
160J16	16.5	419	0.12
160J24	16.5	419	0.19
160J30	16.5	419	0.23
170J2	17.5	445	0.02
170J3	17.5	445	0.03
170J4	17.5	445	0.03
170J5	17.5	445	0.04

Part Number	Outside Circumference (inches)	Outside Circumference (mm)	Weight (lbs.)
170J6	17.5	445	0.05
170J8	17.5	445	0.07
170J10	17.5	445	0.08
170J16	17.5	445	0.13
170J24	17.5	445	0.20
170J30	17.5	445	0.25
180J2	18.5	470	0.02
180J3	18.5	470	0.03
180J4	18.5	470	0.04
180J5	18.5	470	0.04
180J6	18.5	470	0.05
180J7	18.5	470	0.79
180J8	18.5	470	0.07
180J10	18.5	470	0.09
180J16	18.5	470	0.14
180J24	18.5	470	0.21
180J30	18.5	470	0.26
190J2	19.5	495	0.02
190J3	19.5	495	0.03
190J4	19.5	495	0.04
190J5	19.5	495	0.05
190J6	19.5	495	0.06
190J8	19.5	495	0.07
190J10	19.5	495	0.09
190J13	19.5	495	0.15
190J15	19.5	495	0.01
190J16	19.5	495	0.15
190J24	19.5	495	0.22
190J30	19.5	495	0.28
195J7	20	508	0.06
195J8	20	508	0.07
200J2	20.5	521	0.02
200J3	20.5	521	0.03
200J4	20.5	521	0.04
200J5	20.5	521	0.05
200J6	20.5	521	0.06

Vee-Rib™ V-Belt Part Numbers

Part Number	Outside Circumference (inches)	Outside Circumference (mm)	Weight (lbs.)
200J8	20.5	521	0.08
200J10	20.5	521	0.10
200J16	20.5	521	0.16
200J24	20.5	521	0.23
200J30	20.5	521	0.29
200J40	20.5	521	0.39
203J8	20.8	528	0.11
210J2	21.5	546	0.02
210J3	21.5	546	0.03
210J4	21.5	546	0.04
210J5	21.5	546	0.05
210J6	21.5	546	0.06
210J8	21.5	546	0.08
210J10	21.5	546	0.10
210J13	21.5	546	0.17
210J16	21.5	546	0.16
210J24	21.5	546	0.24
210J30	21.5	546	0.31
210J40	21.5	546	0.41
220J2	22.5	572	0.02
220J3	22.5	572	0.03
220J4	22.5	572	0.04
220J5	22.5	572	0.05
220J6	22.5	572	0.06
220J8	22.5	572	0.09
220J9	22.5	572	0.01
220J10	22.5	572	0.11
220J12	22.5	572	0.13
220J16	22.5	572	0.17
220J24	22.5	572	0.26
220J30	22.5	572	0.32
220J40	22.5	572	0.43
230J2	23.5	597	0.02
230J3	23.5	597	0.03
230J4	23.5	597	0.05
230J5	23.5	597	0.06

Part Number	Outside Circumference (inches)	Outside Circumference (mm)	Weight (lbs.)
230J6	23.5	597	0.07
230J8	23.5	597	0.09
230J9	23.5	597	0.01
230J10	23.5	597	0.11
230J11	23.5	597	0.01
230J16	23.5	597	0.18
230J24	23.5	597	0.27
230J30	23.5	597	0.34
230J40	23.5	597	0.45
240J2	24.5	622	0.02
240J3	24.5	622	0.04
240J4	24.5	622	0.05
240J5	24.5	622	0.06
240J6	24.5	622	0.07
240J8	24.5	622	0.09
240J10	24.5	622	0.12
240J12	24.5	622	0.01
240J13	24.5	622	0.20
240J16	24.5	622	0.19
240J24	24.5	622	0.28
240J30	24.5	622	0.35
240J40	24.5	622	0.47
260J2	26.5	673	0.03
260J3	26.5	673	0.04
260J4	26.5	673	0.05
260J5	26.5	673	0.06
260J6	26.5	673	0.08
260J8	26.5	673	0.10
260J9	26.5	673	1.58
260J10	26.5	673	0.13
260J12	26.5	673	0.14
260J13	26.5	673	0.01
260J16	26.5	673	0.20
260J24	26.5	673	0.30
260J30	26.5	673	0.38
260J40	26.5	673	0.50

Vee-Rib™ V-Belt

Part Number Example: **440J4** = **440** **J** **4**
Effective Length (inches in tenths: 44.0") Cross Section Number of Ribs

Part Number	Outside Circumference (inches)	Outside Circumference (mm)	Weight (lbs.)
270J4	27.5	699	0.07
270J6	27.5	699	1.97
270J8	27.5	699	2.61
270J10	27.5	699	0.12
270J12	27.5	699	0.16
270J24	27.5	699	2.61
270J40	27.5	699	1.58
280J2	28.5	724	0.03
280J3	28.5	724	0.04
280J4	28.5	724	0.05
280J5	28.5	724	0.07
280J6	28.5	724	0.08
280J8	28.5	724	0.11
280J9	28.5	724	1.38
280J10	28.5	724	0.14
280J12	28.5	724	0.01
280J16	28.5	724	0.22
280J20	28.5	724	0.01
280J24	28.5	724	0.33
280J30	28.5	724	0.41
280J40	28.5	724	0.54
290J2	29.5	749	0.03
290J3	29.5	749	0.04
290J4	29.5	749	0.06
290J5	29.5	749	0.07
290J6	29.5	749	0.08
290J8	29.5	749	0.11
290J10	29.5	749	0.14
290J16	29.5	749	0.23
290J24	29.5	749	0.34
290J30	29.5	749	0.42
290J40	29.5	749	0.56
300J2	30.5	775	0.03
300J3	30.5	775	0.04
300J4	30.5	775	0.06
300J5	30.5	775	0.07

Part Number	Outside Circumference (inches)	Outside Circumference (mm)	Weight (lbs.)
300J6	30.5	775	0.09
300J8	30.5	775	0.12
300J10	30.5	775	0.15
300J12	30.5	775	0.01
300J15	30.5	775	5.06
300J16	30.5	775	0.23
300J24	30.5	775	0.35
300J30	30.5	775	0.44
300J40	30.5	775	0.58
310J2	31.5	800	0.03
310J3	31.5	800	0.05
310J4	31.5	800	0.06
310J5	31.5	800	0.08
310J6	31.5	800	0.09
310J8	31.5	800	0.12
310J10	31.5	800	0.15
310J12	31.5	800	0.01
310J16	31.5	800	0.24
310J24	31.5	800	0.36
310J30	31.5	800	0.45
310J40	31.5	800	0.60
320J2	32.5	826	0.03
320J3	32.5	826	0.05
320J4	32.5	826	0.06
320J5	32.5	826	0.08
320J6	32.5	826	0.09
320J8	32.5	826	0.12
320J9	32.5	826	0.14
320J10	32.5	826	0.16
320J12	32.5	826	0.02
320J13	32.5	826	5.11
320J16	32.5	826	0.25
320J20	32.5	826	3.56
320J22	32.5	826	2.64
320J24	32.5	826	0.37
320J30	32.5	826	0.47

Vee-Rib™ V-Belt Part Numbers

Part Number	Outside Circumference (inches)	Outside Circumference (mm)	Weight (lbs.)
320J40	32.5	826	0.62
330J2	33.5	851	0.03
330J3	33.5	851	0.05
330J4	33.5	851	0.06
330J5	33.5	851	0.08
330J6	33.5	851	0.10
330J8	33.5	851	0.13
330J10	33.5	851	0.16
330J16	33.5	851	0.26
330J19	33.5	851	0.36
330J24	33.5	851	0.38
330J30	33.5	851	0.48
330J40	33.5	851	0.64
340J2	34.5	876	0.03
340J3	34.5	876	0.05
340J4	34.5	876	0.07
340J5	34.5	876	0.08
340J6	34.5	876	0.10
340J7	34.5	876	0.02
340J8	34.5	876	0.13
340J10	34.5	876	0.17
340J12	34.5	876	0.02
340J13	34.5	876	2.79
340J14	34.5	876	0.02
340J16	34.5	876	0.26
340J24	34.5	876	0.40
340J30	34.5	876	0.50
340J40	34.5	876	0.66
350J2	35.5	902	0.03
350J3	35.5	902	0.05
350J4	35.5	902	0.07
350J5	35.5	902	0.09
350J6	35.5	902	0.10
350J8	35.5	902	0.14
350J10	35.5	902	0.17
350J12	35.5	902	3.21

Part Number	Outside Circumference (inches)	Outside Circumference (mm)	Weight (lbs.)
350J16	35.5	902	0.27
350J24	35.5	902	0.41
350J30	35.5	902	0.51
350J40	35.5	902	0.68
360J2	36.5	927	0.04
360J3	36.5	927	0.05
360J4	36.5	927	0.07
360J5	36.5	927	0.09
360J6	36.5	927	0.11
360J8	36.5	927	0.14
360J9	36.5	927	1.68
360J10	36.5	927	0.18
360J12	36.5	927	0.02
360J13	36.5	927	0.32
360J15	36.5	927	4.93
360J16	36.5	927	0.28
360J24	36.5	927	0.42
360J30	36.5	927	0.52
360J40	36.5	927	0.70
370J2	37.5	953	0.04
370J3	37.5	953	0.05
370J4	37.5	953	0.07
370J5	37.5	953	0.09
370J6	37.5	953	0.11
370J8	37.5	953	0.14
370J10	37.5	953	0.18
370J12	37.5	953	0.20
370J13	37.5	953	0.22
370J16	37.5	953	0.29
370J24	37.5	953	0.43
370J30	37.5	953	0.54
370J40	37.5	953	0.72
380J2	38.5	978	0.04
380J3	38.5	978	0.06
380J4	38.5	978	0.07
380J5	38.5	978	0.09

Vee-Rib™ V-Belt

Part Number Example: **240J8** = **240** **J** **8**
Effective Length (inches in tenths: 24.0") Cross Section Number of Ribs

Part Number	Outside Circumference (inches)	Outside Circumference (mm)	Weight (lbs.)
380J6	38.5	978	0.11
380J7	38.5	978	0.13
380J8	38.5	978	0.15
380J10	38.5	978	0.18
380J12	38.5	978	0.02
380J13	38.5	978	3.36
380J16	38.5	978	0.30
380J24	38.5	978	0.44
380J30	38.5	978	0.55
380J40	38.5	978	0.74
390J2	39.5	1003	0.04
390J3	39.5	1003	0.06
390J4	39.5	1003	0.08
390J5	39.5	1003	0.10
390J6	39.5	1003	0.11
390J8	39.5	1003	0.15
390J9	39.5	1003	0.02
390J10	39.5	1003	0.19
390J13	39.5	1003	1.13
390J16	39.5	1003	0.30
390J20	39.5	1003	0.02
390J24	39.5	1003	0.45
390J30	39.5	1003	0.57
390J40	39.5	1003	0.76
400J2	40.5	1029	0.04
400J3	40.5	1029	0.06
400J4	40.5	1029	0.08
400J5	40.5	1029	0.10
400J6	40.5	1029	0.12
400J8	40.5	1029	0.16
400J9	40.5	1029	0.17
400J10	40.5	1029	0.19
400J12	40.5	1029	0.22
400J15	40.5	1029	0.95
400J16	40.5	1029	0.31
400J24	40.5	1029	0.47

Part Number	Outside Circumference (inches)	Outside Circumference (mm)	Weight (lbs.)
400J30	40.5	1029	0.58
400J40	40.5	1029	0.78
410J2	41.5	1054	0.04
410J3	41.5	1054	0.06
410J4	41.5	1054	0.08
410J5	41.5	1054	0.10
410J6	41.5	1054	0.12
410J8	41.5	1054	0.16
410J10	41.5	1054	0.20
410J16	41.5	1054	0.32
410J24	41.5	1054	0.48
410J30	41.5	1054	0.60
410J40	41.5	1054	0.80
420J2	42.5	1080	0.04
420J3	42.5	1080	0.06
420J4	42.5	1080	0.08
420J5	42.5	1080	0.10
420J6	42.5	1080	0.12
420J8	42.5	1080	0.16
420J9	42.5	1080	0.02
420J10	42.5	1080	0.20
420J12	42.5	1080	0.23
420J16	42.5	1080	0.33
420J24	42.5	1080	0.49
420J30	42.5	1080	0.61
420J40	42.5	1080	0.82
430J2	43.5	1105	0.04
430J3	43.5	1105	0.06
430J4	43.5	1105	0.08
430J5	43.5	1105	0.10
430J6	43.5	1105	0.13
430J7	43.5	1105	0.04
430J8	43.5	1105	0.17
430J10	43.5	1105	0.21
430J12	43.5	1105	0.02
430J16	43.5	1105	0.33

Vee-Rib™ V-Belt Part Numbers

Part Number	Outside Circumference (inches)	Outside Circumference (mm)	Weight (lbs.)
430J20	43.5	1105	0.02
430J24	43.5	1105	0.50
430J30	43.5	1105	0.63
430J40	43.5	1105	0.83
430J60	43.5	1105	4.44
440J2	44.5	1130	0.04
440J3	44.5	1130	0.06
440J4	44.5	1130	0.09
440J5	44.5	1130	0.11
440J6	44.5	1130	0.13
440J8	44.5	1130	0.17
440J10	44.5	1130	0.21
440J16	44.5	1130	0.34
440J20	44.5	1130	0.40
440J24	44.5	1130	0.51
440J30	44.5	1130	0.64
440J40	44.5	1130	0.85
450J2	45.5	1156	0.04
450J3	45.5	1156	0.07
450J4	45.5	1156	0.09
450J5	45.5	1156	0.11
450J6	45.5	1156	0.13
450J7	45.5	1156	0.02
450J8	45.5	1156	0.18
450J10	45.5	1156	0.22
450J16	45.5	1156	0.35
450J24	45.5	1156	0.52
450J30	45.5	1156	0.66
450J40	45.5	1156	0.87
460J2	46.5	1181	0.05
460J3	46.5	1181	0.07
460J4	46.5	1181	0.09
460J5	46.5	1181	0.11
460J6	46.5	1181	0.13
460J8	46.5	1181	0.18
460J10	46.5	1181	0.22

Part Number	Outside Circumference (inches)	Outside Circumference (mm)	Weight (lbs.)
460J16	46.5	1181	0.36
460J19	46.5	1181	0.47
460J24	46.5	1181	0.54
460J30	46.5	1181	0.67
460J40	46.5	1181	0.89
470J4	47.5	1207	0.09
470J6	47.5	1207	0.14
470J8	47.5	1207	0.17
470J10	47.5	1207	0.65
470J12	47.5	1207	0.56
470J16	47.5	1207	0.62
470J20	47.5	1207	0.43
470J40	47.5	1207	0.90
480J5	48.5	1232	4.22
480J6	48.5	1232	0.13
480J8	48.5	1232	0.10
480J15	48.5	1232	3.36
480J16	48.5	1232	7.53
480J20	48.5	1232	0.44
480J40	48.5	1232	0.56
490J2	49.5	1257	0.05
490J3	49.5	1257	0.07
490J4	49.5	1257	0.10
490J5	49.5	1257	0.12
490J6	49.5	1257	0.14
490J7	49.5	1257	0.47
490J8	49.5	1257	0.19
490J10	49.5	1257	0.24
490J12	49.5	1257	0.02
490J16	49.5	1257	0.38
490J24	49.5	1257	0.57
490J30	49.5	1257	0.71
490J32	49.5	1257	4.34
490J40	49.5	1257	0.95
500J6	50.5	1283	0.02
500J7	50.5	1283	0.17

Vee-Rib™ V-Belt

Part Number Example: **240J8** = **840** **J** **16**
Effective Length (inches in tenths: 84.0") Cross Section Number of Ribs

Part Number	Outside Circumference (inches)	Outside Circumference (mm)	Weight (lbs.)
500J8	50.5	1283	1.47
500J10	50.5	1283	1.13
500J40	50.5	1283	0.96
520J2	52.5	1334	0.05
520J3	52.5	1334	0.08
520J4	52.5	1334	0.10
520J5	52.5	1334	0.13
520J6	52.5	1334	0.15
520J8	52.5	1334	0.20
520J10	52.5	1334	0.25
520J12	52.5	1334	0.02
520J15	52.5	1334	0.02
520J16	52.5	1334	0.40
520J24	52.5	1334	0.61
520J30	52.5	1334	0.76
520J40	52.5	1334	1.01
530J2	53.5	1359	0.05
530J3	53.5	1359	0.08
530J4	53.5	1359	0.10
530J5	53.5	1359	0.13
530J6	53.5	1359	0.15
530J8	53.5	1359	0.21
530J10	53.5	1359	0.26
530J16	53.5	1359	0.41
530J24	53.5	1359	0.62
530J30	53.5	1359	0.77
530J40	53.5	1359	1.03
540J2	54.5	1384	0.05
540J3	54.5	1384	0.08
540J4	54.5	1384	0.11
540J5	54.5	1384	0.13
540J6	54.5	1384	0.16
540J8	54.5	1384	0.21
540J10	54.5	1384	0.26
540J16	54.5	1384	0.42
540J18	54.5	1384	5.15

Part Number	Outside Circumference (inches)	Outside Circumference (mm)	Weight (lbs.)
540J24	54.5	1384	0.63
540J30	54.5	1384	0.79
540J40	54.5	1384	1.05
550J2	55.5	1410	0.05
550J3	55.5	1410	0.08
550J4	55.5	1410	0.11
550J5	55.5	1410	0.13
550J6	55.5	1410	0.16
550J8	55.5	1410	0.21
550J10	55.5	1410	0.27
550J12	55.5	1410	0.32
550J14	55.5	1410	1.56
550J16	55.5	1410	0.43
550J18	55.5	1410	0.81
550J24	55.5	1410	0.64
550J30	55.5	1410	0.80
550J40	55.5	1410	1.07
580J2	58.5	1486	0.11
580J3	58.5	1486	0.08
580J4	58.5	1486	0.11
580J5	58.5	1486	0.14
580J6	58.5	1486	0.17
580J8	58.5	1486	0.23
580J10	58.5	1486	0.28
580J16	58.5	1486	0.45
580J24	58.5	1486	0.68
580J26	58.5	1486	0.03
580J30	58.5	1486	0.84
580J40	58.5	1486	1.13
610J2	61.5	1562	0.06
610J3	61.5	1562	0.09
610J4	61.5	1562	0.12
610J5	61.5	1562	0.15
610J6	61.5	1562	0.18
610J8	61.5	1562	0.24
610J10	61.5	1562	0.30

Vee-Rib™ V-Belt Part Numbers

Part Number	Outside Circumference (inches)	Outside Circumference (mm)	Weight (lbs.)
610J14	61.5	1562	0.03
610J16	61.5	1562	0.47
610J24	61.5	1562	0.71
610J30	61.5	1562	0.89
610J40	61.5	1562	1.18
650J2	65.5	1664	0.06
650J3	65.5	1664	0.10
650J4	65.5	1664	0.13
650J5	65.5	1664	0.16
650J6	65.5	1664	0.19
650J7	65.5	1664	5.10
650J8	65.5	1664	0.25
650J10	65.5	1664	0.32
650J12	65.5	1664	0.18
650J15	65.5	1664	4.92
650J16	65.5	1664	0.50
650J24	65.5	1664	0.76
650J30	65.5	1664	0.95
650J40	65.5	1664	1.26
690J2	69.5	1765	0.07
690J3	69.5	1765	0.10
690J4	69.5	1765	0.13
690J5	69.5	1765	0.17
690J6	69.5	1765	0.20
690J8	69.5	1765	0.27
690J10	69.5	1765	0.34
690J12	69.5	1765	0.56
690J14	69.5	1765	0.03
690J16	69.5	1765	0.54
690J24	69.5	1765	0.80
690J30	69.5	1765	1.00
690J40	69.5	1765	1.34
730J2	73.5	1867	0.07
730J3	73.5	1867	0.11
730J4	73.5	1867	0.14
730J5	73.5	1867	0.18

Part Number	Outside Circumference (inches)	Outside Circumference (mm)	Weight (lbs.)
730J6	73.5	1867	0.21
730J8	73.5	1867	0.28
730J10	73.5	1867	0.35
730J12	73.5	1867	1.18
730J16	73.5	1867	0.57
730J24	73.5	1867	0.85
730J30	73.5	1867	1.06
730J40	73.5	1867	1.42
770J2	77.5	1969	0.08
770J3	77.5	1969	0.11
770J4	77.5	1969	0.15
770J5	77.5	1969	0.19
770J6	77.5	1969	0.22
770J7	77.5	1969	0.84
770J8	77.5	1969	0.30
770J10	77.5	1969	0.37
770J11	77.5	1969	0.62
770J12	77.5	1969	0.44
770J16	77.5	1969	0.60
770J24	77.5	1969	0.90
770J30	77.5	1969	1.12
770J40	77.5	1969	1.49
820J2	82.5	2096	0.08
820J3	82.5	2096	0.12
820J4	82.5	2096	0.16
820J5	82.5	2096	0.20
820J6	82.5	2096	0.24
820J8	82.5	2096	0.32
820J9	82.5	2096	2.13
820J10	82.5	2096	0.40
820J16	82.5	2096	0.64
820J24	82.5	2096	0.96
820J30	82.5	2096	1.19
840J2	84.5	2146	0.08
840J3	84.5	2146	0.12
840J4	84.5	2146	0.16

Vee-Rib™ V-Belt

Part Number	Outside Circumference (inches)	Outside Circumference (mm)	Weight (lbs.)
840J5	84.5	2146	0.20
840J6	84.5	2146	0.24
840J8	84.5	2146	0.33
840J10	84.5	2146	0.41
840J16	84.5	2146	0.65
840J24	84.5	2146	0.98
840J30	84.5	2146	1.22
840J40	84.5	2146	1.63
870J3	87.5	2223	0.12
870J6	87.5	2223	1.45
870J10	87.5	2223	2.42
890J2	89.5	2273	0.09
890J3	89.5	2273	0.13
890J4	89.5	2273	0.17
890J5	89.5	2273	0.22
890J6	89.5	2273	0.26
890J8	89.5	2273	0.35
890J40	89.5	2273	1.73
910J6	91.5	2324	0.38
920J2	92.5	2350	0.09
920J3	92.5	2350	0.13
920J4	92.5	2350	0.18
920J5	92.5	2350	0.22
920J6	92.5	2350	0.27
920J8	92.5	2350	0.36
920J9	92.5	2350	0.38
920J10	92.5	2350	0.45
920J16	92.5	2350	0.71
920J24	92.5	2350	1.07
920J30	92.5	2350	1.34
920J40	92.5	2350	1.79
940J2	94.5	2400	0.09
940J3	94.5	2400	0.14
940J4	94.5	2400	0.18
940J5	94.5	2400	0.23
940J6	94.5	2400	0.27
940J8	94.5	2400	0.37

Part Number	Outside Circumference (inches)	Outside Circumference (mm)	Weight (lbs.)
940J10	94.5	2400	0.46
940J16	94.5	2400	0.73
940J24	94.5	2400	1.09
970J2	97.5	2477	0.09
970J3	97.5	2477	0.14
970J4	97.5	2477	0.19
970J5	97.5	2477	0.24
970J6	97.5	2477	0.28
970J8	97.5	2477	0.38
970J10	97.5	2477	0.47
970J16	97.5	2477	0.75
970J24	97.5	2477	1.13
970J30	97.5	2477	1.41
980J2	98.5	2502	0.10
980J3	98.5	2502	0.14
980J4	98.5	2502	0.19
980J5	98.5	2502	0.24
980J6	98.5	2502	0.29
980J8	98.5	2502	0.38
980J10	98.5	2502	0.48
980J12	98.5	2502	0.54
980J16	98.5	2502	0.76
980J24	98.5	2502	1.14
980J30	98.5	2502	1.43
980J40	98.5	2502	1.90
1000J3	100.5	2553	0.37
1000J6	100.5	2553	0.08
1000J40	100.5	2553	2.77

Vee-Rib Sleeve

Vee-Rib J Sleeve Part Numbers

- Full factory width sleeves
- Sleeve edges are trimmed prior to shipment
- Sleeves cannot be returned

Timken maintains inventory of most sleeve sizes. Contact customer service for availability.

Part Number Example: **200J40** = **200** **J** **40**
Effective Length (inches in tenths: 20.0") Cross Section Number of Ribs

Minimum order quantity and/or extended lead times may apply.

Occasional production inconsistencies which may render a portion of the sleeve unusable can be present as a normal part of the production process.

Each sleeve is inspected to ensure that it contains 90% or more usable product. A full width sleeve with less than 10% unusable product is considered acceptable.

Part Number	Number of Ribs	Outside Circumference (inches)	Outside Circumference (mm)	Weight (lbs.)
J Sleeves (40-Rib)				
200JSL	40	20.5	521	0.4
210JSL	40	21.5	546	0.4
220JSL	40	22.5	572	0.4
230JSL	40	23.5	597	0.4
240JSL	40	24.5	622	0.5
260JSL	40	26.5	673	0.5
270JSL	40	27.5	699	1.6
280JSL	40	28.5	724	0.5
290JSL	40	29.5	749	0.6
300JSL	40	30.5	775	0.6
310JSL	40	31.5	800	0.6
320JSL	40	32.5	826	0.6
330JSL	40	33.5	851	0.6
340JSL	40	34.5	876	0.7
350JSL	40	35.5	902	0.7
360JSL	40	36.5	927	0.7
370JSL	40	37.5	953	0.7
380JSL	40	38.5	978	0.7
390JSL	40	39.5	1003	0.8
400JSL	40	40.5	1029	0.8
410JSL	40	41.5	1054	0.8
420JSL	40	42.5	1080	0.8
430JSL	40	43.5	1105	0.8

Part Number	Number of Ribs	Outside Circumference (inches)	Outside Circumference (mm)	Weight (lbs.)
J Sleeves (40-Rib)				
440JSL	40	44.5	1130	0.9
450JSL	40	45.5	1156	0.9
460JSL	40	46.5	1181	0.9
470JSL	40	47.5	1207	0.9
480JSL	40	48.5	1232	0.6
490JSL	40	49.5	1257	1.0
500JSL	40	50.5	1283	1.0
520JSL	40	52.5	1334	1.0
530JSL	40	53.5	1359	1.0
540JSL	40	54.5	1384	1.0
550JSL	40	55.5	1410	1.1
580JSL	40	58.5	1486	1.1
610JSL	40	61.5	1562	1.2
650JSL	40	65.5	1664	1.3
690JSL	40	69.5	1765	1.3
730JSL	40	73.5	1867	1.4
770JSL	40	77.5	1969	1.5
840JSL	40	84.5	2146	1.6
890JSL	40	89.5	2273	1.7
920JSL	40	92.5	2350	1.8
980JSL	40	98.5	2502	1.9
1000JSL	40	100.5	2553	2.8

Specialty Belts



Specialty Belts



Cotton Drive® Timing Belt

Specialty Belts

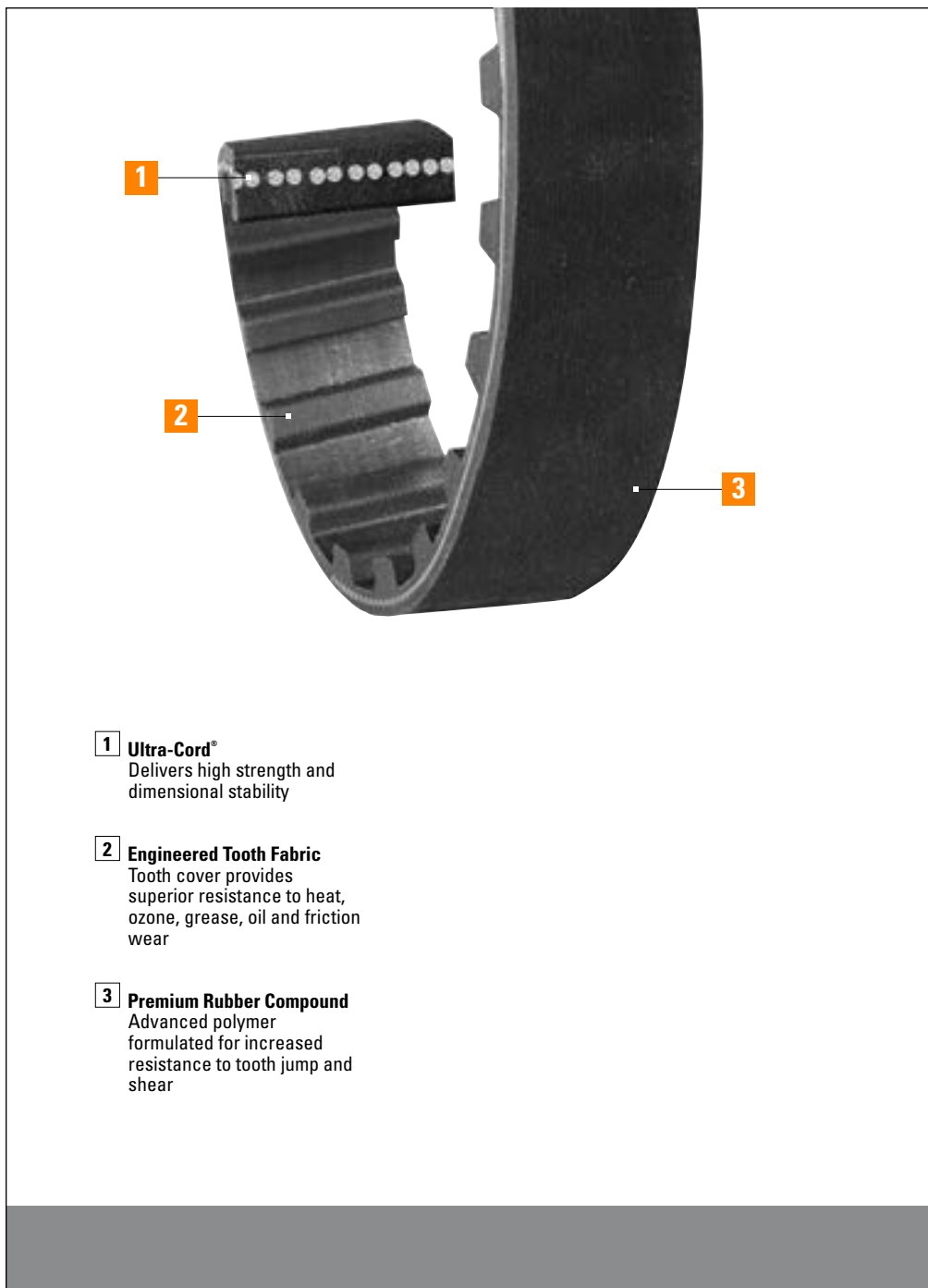

- 1 Ultra-Cord®**
Delivers high strength and dimensional stability
- 2 Engineered Tooth Fabric**
Tooth cover provides superior resistance to heat, ozone, grease, oil and friction wear
- 3 Premium Rubber Compound**
Advanced polymer formulated for increased resistance to tooth jump and shear

Ultra-Cord® tensile member

Designed for exact OEM replacement on cotton gin drives

Uniquely constructed for optimum performance in this harsh application

Cotton Drive® Timing Belt

Specialty Belts

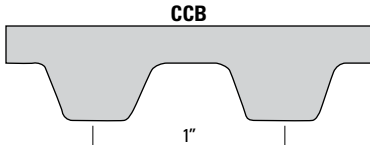

Cotton Drive® belts are special 1" pitch timing belts designed for use on cotton gin incline cleaner machines. The belts are specially constructed to handle this harsh, abrasive application.

Features/Advantages

- Ultra-Cord® tensile member delivers strength and dimensional stability
- Advanced polymer compound resists jump and tooth shear
- Long belt life
- Low tension decay
- Resistant to heat, ozone, grease, oil and friction wear
- Made in USA

Cotton Drive® Belt Part Numbers

Part Number	Number of Teeth	Top Width	Pitch Length (inches)	Weight (lbs.)
61CCB142	61	1.5	61.07	2.0
63CCB165	63	1.5	63.00	2.1
63CCB165-2-1/2	63	2.5	63.00	3.5
64CCB170	64	1.5	63.95	2.2
65CCB175	65	1.5	64.95	2.3



Dry Can Belt

Specialty Belts



1 Polyester Cord
Multiple plies of high-modulus cord carry the horsepower load with minimum stretch. Adds belt strength and stability during peak shock loads.

2 Compression Section
Synthetic rubber compound designed to support the cords evenly and compress while bending around the sheaves

3 Deep-Groove Notches
Notched design for greater flexibility and increased life

4 Heavy Duty Cover
Stress-relieved fabric impregnated with engineered rubber compounds protects the core and assures a smooth transfer of power. Resistant to oil, heat, and environmental conditions

Recommended Pulleys:
Conventional – OD, Taper Bushed, or MST (C)

Special construction CC cross section

Power transmission from both sides of the belt

Deep-groove notches for flexibility and long life

Multiple plies of high-modulus cord

Oil, heat, ozone, and abrasion resistant

Static conductive

Applications:
Textile industry
Drying cans

Dry Can Belt

Specialty Belts

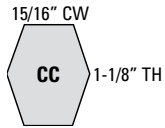

Part Number Example: **CC600S** = **CC** **600** **S**
Cross Section Double Angle Pitch Length (inches) Notched Cog Construction

Dry Can belts are designed with deep-groove notches specifically developed for “CC” drives commonly found in the demanding textile industry

Deep groove double “CC” belts are designed for drives with long center, serpentine applications commonly found in the demanding textile industry. The deep groove minimizes belt rollover while the notches provide added flexibility and long belt life with dependable power from both sides of the belt.

Features/Advantages

- Special construction deep groove CC cross section
- Strong yet flexible for power transmission from both sides of the belt
- Multiple ply cord provides superior strength and durability with minimal stretch
- Oil, heat, ozone, and abrasion resistant

Important Application Information

Dry Can belts are normally used as a single belt on a drive and matching is not required. When ordering two or more Dry Can belts to be used as a matched set on the same drive, please specify that the belts must be a matched set.

Dry Can Specialty Belt Part Numbers

Part Number	Outside Circumference (inches)	Outside Circumference (mm)	Weight (lbs.)
C Belt Recommended Pulleys: Conventional – QD, Taper Bushed, or MST (C)			
CC210S	214.1	5438	8.0
CC240S	242.1	6149	9.0
CC270S	272.1	6911	10.1
CC300S	302.1	7673	11.3
CC330S	332.1	8435	12.4
CC360S	362.1	9197	13.5
CC390S	392.1	9959	14.6
CC420S	422.1	10721	15.7
CC440S	442.1	11229	16.5
CC450S	452.1	11483	16.8
CC480S	482.1	12245	18.0
CC540S	542.1	13769	20.2
CC550S	552.1	14023	20.6
CC600S	602.1	15293	22.4
CC640S	642.1	16309	23.9
CC660S	662.1	16817	24.7
CC670S	672.1	17071	25.0
CC680S	682.1	17325	25.4
CC700S	702.1	17833	26.2
CC720S	722.1	18341	26.9
CC750S	752.1	19103	28.0
CC780S	782.1	19865	29.1
CC800S	802.1	20373	29.9
CC840S	842.1	21389	31.4
CC900S	902.1	22913	33.6

For sizes not listed contact customer service for availability. Minimum order quantity and/or extended lead times may apply.

Feather Picker V-Belt

Specialty Belts



1 EPDM
Durable and resistant to heat, hardening, glazing, steam and moisture

2 Oversized Polyester Cord
High-modulus cord carries the horsepower load with minimum stretch. Adds belt strength and stability during peak shock loads.

3 Double Cog
Double sided molded cogs are engineered for superior flexibility

4 Raw Edge Sidewalls
Enhanced gripping power and long belt life

Gripping power of raw edge sidewalls

Superior flexing of precision molded cogs

Durability of highly engineered polymer

High strength tensile cord

Resistant to heat, steam and moisture

Resistant to wear, hardening and glazing

Broad operating temperature range
-50°F to +250°F

Belts are sold in matched sets of 2

- Never mix new and used belts on a drive
- Never mix belts from different manufacturers

Available in AAX and BBX sizes.

Other sizes and constructions are available as made-to-order belts

Feather Picker V-Belt

V-Belts

Part Number Example: **BBX155FP** = **BB** **X** **155** **FP**
Cross Section Cogged Construction Inside Circumference (inches) Feather Picker

Timken Feather Picker belts are made of Ethylene Propylene Diene Monomer (EPDM) which is durable, and resistant to heat, hardening and glazing. Feather Picker belts offer superior flex and load carrying capacity, resist cracking and won't stretch.

Reduce downtime and maintenance costs with premium quality Timken belts for poultry processing equipment. The feather picking machine is a critical application in poultry processing plants. Downtime on this machine alone stops the entire process. The belts that operate in this harsh environment must be reliable. Feather Picker belts are made of an advanced polymer and optimized tensile cord for improved wear resistance and long belt life. The unique double sided molded cog design is engineered for flexibility and enhanced grip in moist conditions. Feather Picker belts resist steam and moisture better than competitive wrapped belt constructions.



Belts are sold in matched sets of 2

Feather Picker Part Numbers

Part Number	Outside Circumference (inches)	Outside Circumference (mm)	Weight (lbs.)
AAX			
AAX128FP	131.3	3335	4.7
AAX142FP	145.3	3691	5.2
AAX144FP	147.3	3741	5.2
AAX146FP	149.3	3792	5.3
AAX148FP	151.3	3843	5.4
AAX161FP	164.3	4173	5.8
AAX163FP	166.3	4224	5.9
AAX184FP	187.3	4757	6.7
BBX			
BBX155FP	160.2	4069	7.6
BBX158FP	163.2	4145	7.8
BBX161FP	166.2	4221	7.7
BBX168FP	173.2	4399	8.2
BBX172FP	177.2	4501	8.4
BBX185FP	180.2	4577	9.1
BBX195FP	200.2	5085	9.5

Flour Power™ Roller Mill Belt

Specialty Belts



1 Tensile Member
Optimized cord for strength and high torque loading

2 Rubber Compound
Advanced polymer provides optimal performance and long belt life

3 Teeth
Jump and shear resistant teeth

4 Nylon Tooth Facing
Graphite impregnated fabric is wear resistant

Efficient and consistent power transfer

Heat, abrasion and wear resistant

Durable and dependable

Available in matched sets

Smooth, vibration-free performance

Market
Food processing industry

Application
Roller mills

Synchronous Belts

V- Belts

Specialty Belts

Tools

General Information

Flour Power™ Roller Mill Belt

Specialty Belts

Part Number Example: **1760-8M-PK12-3** = **1760** **8M** **PK** **12** **3**

Pitch Length (millimeters) Synchronous Side Tooth Pitch V-Ribbed Side Cross Section Number of Ribs Matched Set of 3

Avoid downtime with durable and dependable Flour Power™ roller mill belts.

Roller milling machines are widely used in food-processing. Flour mills run 24 hours a day, seven days a week. Timken Roller Mill belts offer efficient and reliable power transmission in a compact drive solution.

Roller mill drive belts are typically dual sided. Some are constructed as a dual synchronous or dual v-ribbed belt, while others feature a high torque synchronous belt on one side with v-ribbed capability on the other. These Timken specialty belts are designed for optimum performance and drive life while reducing maintenance and downtime.

Features/Advantages

- High performance advanced polymer compound for long belt life
- Optimized tensile cord for strength and high torque loading
- Graphite impregnated fabric facing for improved wear resistance
- Jump and shear resistant belt teeth
- Efficient and consistent power transfer
- Heat, abrasion and wear resistant
- Flexible, vibration-free performance
- Durable and dependable
- Available in matched sets
- Manufactured in ISO 9001:2015 facilities
- Made in USA

Application

- Roller mills
 - Roller milling is a process used to separate the parts of grain and then grind into flour
 - The rollers rotate at different speeds and the material is sheared as it passes through the gap

Matched Sets

- Belts can be ordered in matched sets
 - Add a dash and the number of belts needed as a suffix to the part number

Flour Power Roller Mill Belt Part Numbers

Part Number	Pitch Length (mm)	Number of Teeth	Number of Ribs	Weight (lbs.)
1552-8M-PK12	1552	194	12	1.3
1552-8M-PK16	1552	194	16	1.3
1552-8M-PK16-2	1552	194	16	3.5
1552-8M-PK32	1552	194	32	3.5
1552-8M-PK36	1552	194	36	3.9
1552-8M-PK38	1552	194	38	4.0
1760-8M-PK12	1760	220	12	1.4
1760-8M-PK12-3	1760	220	12	4.3
1760-8M-PK18	1760	220	18	2.1
1760-8M-PK20	1760	220	20	2.4
1760-8M-PK24	1760	220	24	2.8
1760-8M-PK36	1760	220	36	4.3
1760-8M-PK38	1760	220	38	4.5
1778-14M-PK12	1778	127	12	2.0
1778-14M-PK12-3	1778	127	12	5.7
1778-14M-PK36	1778	127	36	6.0
2400-8M-PK12	2400	300	12	1.9
2400-8M-PK12-3	2400	300	12	5.7
2800-8M-PK16	2800	350	16	3.0
2400-8M-PK36	2400	300	36	5.7
1765PVL22D	1765	n/a	22	4.5
1765PVL26D	1765	n/a	26	5.3

Round Specialty Belts

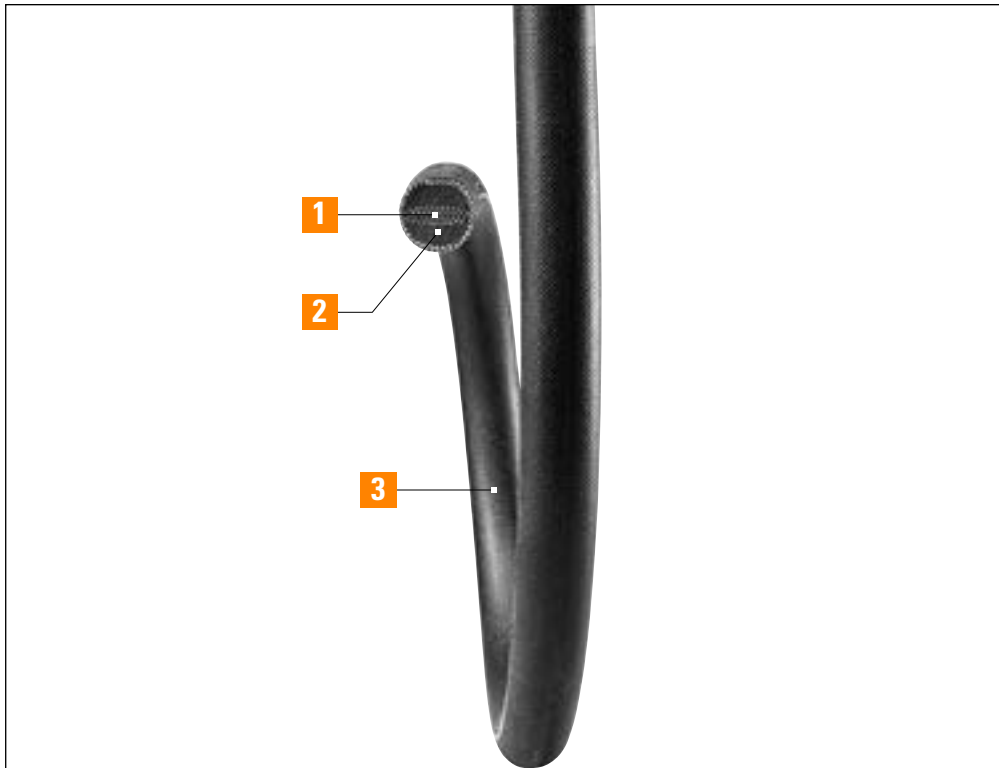

1 High-Modulus Cord
Multiple layers of high-modulus polyester cord provide exceptional flexibility, strength and durability with minimum stretch. Specially treated to produce a long-lasting bond with the surrounding rubber assuring longer belt life

2 Compression Section
Synthetic rubber compound designed to support the cords evenly and compress while bending around the sheaves

3 Heavy Duty Cover
Stress-relieved fabric impregnated with engineered rubber compounds protects the core and assures a smooth transfer of power. Resistant to oil, heat, and environmental conditions.

Recommended Pulleys:
Conventional – OD, Taper Bushed, or MST (A-B)

Minimal stretch for minimum take-up requirements

No splice for added durability

Available in most popular sizes for conveyor applications

Applications:
Conveyors
& More

Round Specialty Belts

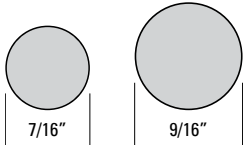

Round belts are a high performance solution for quarter-turn, twisted, and serpentine drives.

Round belts are used on conveyors and other applications with quarter-turn or twisted drives. Timken round belts feature a no-splice construction for added durability. Multiple layers of high-modulus cord provide flexibility and strength. The cover fabric protects the core and assures a smooth transfer of power. Round belts are available in various lengths in 7/16" and 9/16" diameters.

Other sizes are available. Please contact your Timken Belts customer service team. Extended lead times and minimum order quantities may apply.



Round Specialty Belts

Round Belt Part Numbers

Part Number Example: **716R100** = **716** **R** **100**
Diameter (fractional inches 7/16") Round Belt Construction Effective Length (inches)

Part Number	Diameter (in)	Effective Length (in)	Weight (lbs)
7/16" Diameter Recommended Pulleys: Conventional – QD, Taper Bushed, or MST (A-B)			
716R70	7/16"	70	0.6
716R71	7/16"	71	0.6
716R72	7/16"	72	0.6
716R73	7/16"	73	0.6
716R74	7/16"	74	0.6
716R75	7/16"	75	0.6
716R76	7/16"	76	0.6
716R77	7/16"	77	0.9
716R78	7/16"	78	0.4
716R79	7/16"	79	0.4
716R80	7/16"	80	0.4
716R81	7/16"	81	0.4
716R82	7/16"	82	0.5
716R83	7/16"	83	0.5
716R84	7/16"	84	0.5
716R85	7/16"	85	0.5
716R86	7/16"	86	0.5
716R87	7/16"	87	0.5
716R88	7/16"	88	0.5
716R89	7/16"	89	0.5
716R90	7/16"	90	0.5
716R91	7/16"	91	0.5
716R92	7/16"	92	0.5
716R93	7/16"	93	0.5
716R94	7/16"	94	0.5
716R95	7/16"	95	0.5
716R96	7/16"	96	0.5
716R97	7/16"	97	0.5
716R98	7/16"	98	0.6
716R99	7/16"	99	0.6
716R100	7/16"	100	0.6
716R101	7/16"	101	0.6
716R102	7/16"	102	0.6

Part Number	Diameter (in)	Effective Length (in)	Weight (lbs)
7/16" Diameter Recommended Pulleys: Conventional – QD, Taper Bushed, or MST (A-B)			
716R103	7/16"	103	0.6
716R104	7/16"	104	0.6
716R105	7/16"	105	0.6
716R106	7/16"	106	0.6
716R151	7/16"	150.7	0.6
9/16" Diameter Recommended Pulleys: Conventional – QD, Taper Bushed, or MST (A-B)			
916R70	9/16"	70	1.0
916R71	9/16"	71	1.0
916R72	9/16"	72	1.0
916R73	9/16"	73	1.0
916R74	9/16"	74	1.0
916R75	9/16"	75	1.1
916R76	9/16"	76	1.1
916R77	9/16"	77	1.1
916R78	9/16"	78	1.1
916R79	9/16"	79	1.1
916R80	9/16"	80	1.1
916R81	9/16"	81	1.1
916R82	9/16"	82	1.1
916R83	9/16"	83	1.1
916R84	9/16"	84	1.2
916R85	9/16"	85	1.2
916R86	9/16"	86	1.2
916R87	9/16"	87	1.2
916R88	9/16"	88	1.2
916R89	9/16"	89	1.2
916R90	9/16"	90	1.2
916R91	9/16"	91	1.3
916R92	9/16"	92	1.4
916R93	9/16"	93	1.5
916R94	9/16"	94	1.5
916R95	9/16"	95	1.6

Round Specialty Belts

Round Belt Part Numbers

Part Number Example: **916R96** =

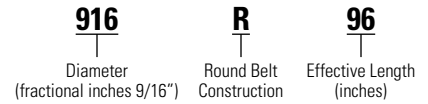

Part Number	Diameter (in)	Effective Length (in)	Weight (lbs)
9/16" Diameter Recommended Pulleys: Conventional – QD, Taper Bushed, or MST (A-B)			
916R96	9/16"	96	1.7
916R97	9/16"	97	1.7
916R98	9/16"	98	1.8
916R99	9/16"	99	1.9
916R100	9/16"	100	2.0
916R101	9/16"	101	2.1
916R102	9/16"	102	2.4
916R103	9/16"	103	2.5
916R104	9/16"	104	2.7
916R105	9/16"	105	3.1
916R106	9/16"	106	3.4
916R107	9/16"	107	3.5
916R108	9/16"	108	3.5
916R109	9/16"	109	3.7
916R110	9/16"	110	3.9
916R111	9/16"	111	4.3
916R112	9/16"	112	4.6
916R113	9/16"	113	4.8
916R114	9/16"	114	5.1
916R115	9/16"	115	5.3
916R116	9/16"	116	5.8
916R117	9/16"	117	5.8
916R118	9/16"	118	6.1
916R119	9/16"	119	6.2
916R120	9/16"	120	6.7
916R128	9/16"	128	0.7
916R135	9/16"	135	0.7
916R144	9/16"	144	0.7
916R148	9/16"	148	0.7
916R155	9/16"	155	0.7
916R166	9/16"	166	0.8
916R172	9/16"	172	0.8

Part Number	Diameter (in)	Effective Length (in)	Weight (lbs)
9/16" Diameter Recommended Pulleys: Conventional – QD, Taper Bushed, or MST (A-B)			
916R176	9/16"	176	7.8
916R190	9/16"	190	0.8
916R200	9/16"	200	0.8
916R210	9/16"	210	0.8
916R233	9/16"	233	0.8
916R250	9/16"	250	0.8
916R270	9/16"	270	0.8
916R308	9/16"	308	0.8
916R331	9/16"	331	0.8
916R341	9/16"	341	0.9
916R345	9/16"	345	0.9
916R366	9/16"	366	0.9
916R386	9/16"	386	0.9
916R416	9/16"	416	0.9
916R447	9/16"	447	0.9
916R465	9/16"	465	0.9
916R500	9/16"	500	0.9
916R522	9/16"	522	0.9
916R564	9/16"	564	0.9
916R572	9/16"	572	1.0
916R600	9/16"	600	1.0
916R603	9/16"	603	1.0
916R660	9/16"	660	1.0
916R762	9/16"	762	1.0

Other sizes are available. Please contact your Timken Belts customer service team. Extended lead times and minimum order quantities may apply.

Super Arc[®] Specialty Belts

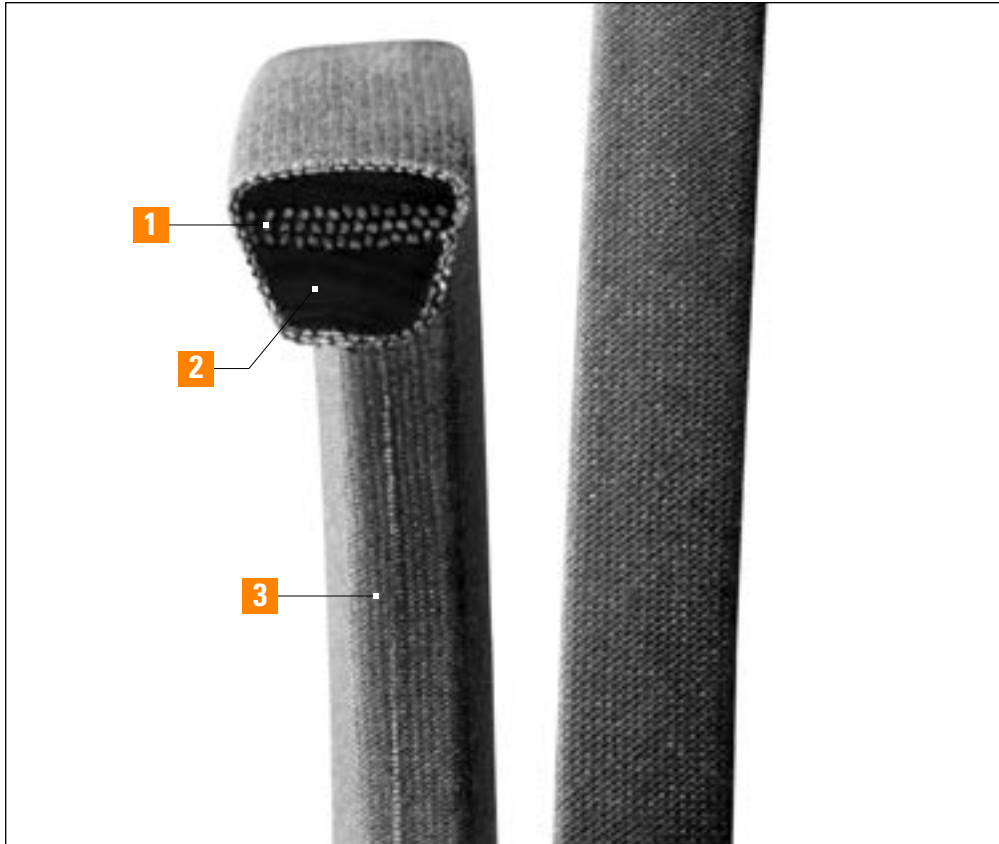

1 High-modulus cord
Multiple layers of polyester cord provide exceptional flexibility, strength and durability

2 Advanced polymer
Highly engineered polymer extends belt life

3 Clutching cover
Superior fabric clutching cover is designed to handle misalignment and enhance wear resistance

Recommended Pulleys:
Conventional – OD, Taper Bushed, or MST (A-B)

Resists extreme stress and wear

Provides just the right amount of slip and grip

Allows the belt to flex around the arc of the conveyor

Excellent flex life

Applications:
Live/powerd roller conveyor drives

Synchronous Belts

V-Belts

Specialty Belts

Tools

General Information

Super Arc[®] Specialty Belts



Part Number Example: **B603SA** = **B** **603** **SA**
Cross Section Inside Circumference Length (Inches) Super Arc Construction

Specialty heavy duty wrapped belt designed to provide improved flexibility, performance and extended belt life on live/powering roller conveyor drives

Super Arc belts are designed to resist the extreme stress and wear experienced on powered roller conveyor drives. The brown clutching cover provides just the right amount of slip and grip between the belt and rollers. The multiple layers of small diameter polyester cord allow the belt to flex around the arc of the conveyor. The highly engineered rubber compound supports the cord, while retaining excellent flex life.

Features/Advantages

- Multiple plies of polyester cord provide exceptional flexibility, strength and durability
- Improved rubber compound helps extend belt life
- Superior fabric clutching cover is designed to handle misalignment and enhance wear resistance
- Oil and heat resistant
- Made in the USA

Note:
 Super Arc belts are NOT static dissipating.
 Super Arc belts are NOT Chek Mate[®] matched.
 Normally used as a single belt on a drive and matching is not required.



Super Arc Belt Part Numbers

Part Number	Diameter (in)	Effective Length (in)	Weight (lbs)
B135SA	138	3505	1.2
B141SA	144	3658	1.3
B152SA	155	3937	1.4
B155SA	158	4013	1.4
B172SA	175	4445	1.6
B173SA	176	4470	1.6
B174SA	177	4496	1.6
B176SA	179	4547	1.6
B180SA	183	4648	1.6
B192SA	195	4953	1.7
B196SA	199	5055	1.8
B200SA	203	5156	1.8
B208SA	211	5359	1.9
B210SA	213	5410	1.9
B213SA	214.5	5448	1.9
B215SA	216.5	5499	1.9
B232SA	233.5	5931	2.1
B234SA	235.5	5982	2.1
B242SA	243.5	6185	2.2
B249SA	250.5	6363	2.2
B250SA	251.5	6388	2.2
B254SA	255.5	6490	2.3
B262SA	263.5	6693	2.4
B270SA	271.5	6896	2.4
B274SA	275.5	6998	2.4
B275SA	276.5	7023	2.5
B278SA	279.5	7099	2.5
B280SA	281.5	7150	2.5
B289SA	290.5	7379	2.6

Super Arc V-Belt Part Numbers

Part Number	Diameter (in)	Effective Length (in)	Weight (lbs)
B295SA	296.5	7531	2.7
B300SA	301.5	7658	2.8
B308SA	309.5	7861	2.8
B315SA	316.5	8039	2.8
B320SA	321.5	8166	2.9
B331SA	332.5	8446	3.0
B345SA	346.5	8801	3.1
B355SA	356.5	9055	3.2
B360SA	361.5	9182	3.3
B366SA	367.5	9335	3.4
B372SA	373.5	9487	3.4
B380SA	381.5	9690	3.5
B386SA	387.5	9843	3.5
B398SA	399.5	10147	3.7
B416SA	417.5	10605	3.8
B430SA	431.5	10960	3.9
B431SA	432.5	10986	3.9
B436SA	437.5	11113	3.9
B447SA	448.5	11392	4.1
B458SA	459.5	11671	4.2
B465SA	466.5	11849	4.3
B473SA	474.5	12052	4.3
B482SA	483.5	12281	4.4
B493SA	494.5	12560	4.5
B494SA	495.5	12586	4.4
B508SA	509.5	12941	4.7
B522SA	523.5	13297	4.8
B525SA	526.5	13373	4.8
B537SA	538.5	13678	4.9
B543SA	544.5	13830	4.9
B553SA	554.5	14084	5.1
B564SA	565.5	14364	5.1
B572SA	573.5	14567	5.1

Part Number	Diameter (in)	Effective Length (in)	Weight (lbs)
B587SA	588.5	14948	5.4
B603SA	604.5	15354	5.4
B618SA	619.5	15735	5.5
B632SA	633.5	16091	5.8
B660SA	661.5	16802	5.5

Super Arc Round Belt Part Numbers

Part Number	Diameter (in)	Effective Length (in)	Weight (lbs)
916R155SA	9/16"	155	1.6
916R200SA	9/16"	200	2.1
916R210SA	9/16"	210	2.1
916R233SA	9/16"	233	2.3
916R308SA	9/16"	308	3.1
916R447SA	9/16"	447	4.5

Super Arc[®] Specialty Belts



Thoro-Twist™ V-Belt

Specialty Belts



1

2

1 Polyurethane
High performance polyurethane elastomer.

2 Fabric
Multiple plies of polyester fabric for high strength.

Recommended Pulleys:
Conventional – QD, Taper Bushed, or MST (A-B, C); FHP – Bore-to-Size and MST (AK, BK)

Link belt for drives with no take-up adjustment capability

Emergency replacement belt

Easy, fast installation

Strong, flexible, fabric reinforced urethane construction

Oil, chemical, and temperature resistant

Applications:
Emergency replacement

Synchronous Belts

V-Belts

Specialty Belts

Tools

General Information

Thoro-Twist™ V-Belt

Specialty Belts

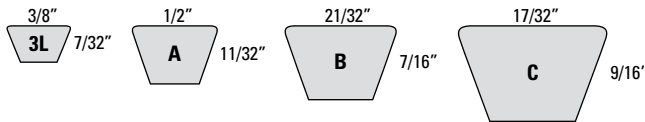

Thoro-Twist is a urethane belt designed for drives that have no take-up adjustment capability or for use as an emergency replacement.

Thoro-Twist is strong, yet flexible with similar horsepower ratings to conventional rubber v-belts. Thoro-Twist v-belts have the same cross section dimensions as regular belts and can be installed on existing sheaves with no changes in setup. Installation is easy. Thoro-Twist can be assembled by hand and rolled onto the drive like a bicycle chain.

- Durable high-performance polyurethane/polyester composite
- Similar horsepower ratings to conventional rubber v-belts
- Same cross section dimensions as conventional v-belts
- Easy, fast installation
- Multiple plies of polyester fabric for high strength
- Resistant to oil, heat, and environmental conditions
- Operating temperature range of -40° F to +240° F
- Long life in harsh operating conditions

Part Number Example: **3LTwist** = **3L** **Twist**
Cross Section Thoro-Twist (link) Belting

Thoro-Twist™ Part Numbers

Part Number	Top Width (inches)	Thickness (inches)	Length (feet)	Length (mm)	Weight (lbs.)
Recommended Pulleys: Conventional – QD, Taper Bushed, or MST (A-B, C); FHP – Bore-to-Size and MST (AK, BK)					
3LTWIST	3/8"	7/32"	98 foot roll	30 meter roll	11.5
ATWIST	1/2"	11/32"	98 foot roll	30 meter roll	5.5
BTWIST	21/32"	7/16"	98 foot roll	30 meter roll	8.9
CTWIST	7/8"	9/16"	98 foot roll	30 meter roll	32.5

Minimum order quantity: One carton, 30 meter roll (approximately 98')

Ensuring long belt life and optimum performance requires more than a quality belt. Timken® belts are backed by a team of experienced sales people, expert engineers, and an array of useful tools that can assist you in properly selecting, installing and maintaining your equipment to realize superior efficiencies and maximum belt life – saving you time and money.

Always eager to assist you in analyzing or designing your next drive, Timken can provide training and guidance in the use of these tools.

Information on how to use these tools can be found at timkenbelts.com or scan the QR code provided.



Drive Engineer®

Belt Drive Design and Analysis Web App

The Drive Engineer web app delivers robust belt drive design and analysis to your desktop or mobile device! It puts drive design and analysis in the palm of your hand, providing extensive results and comprehensive data for use on v-belt or synchronous drives. Belt, pulley and drive output details and specifications can be filtered, changed, saved and shared with the touch of a finger.

Open the web app at: www.driveengineer.com or scan the QR code provided.

It's like having an engineer always at your side! All the experience and expertise of Timken's award-winning belt engineering team is readily available in this handy tool. Whether you need on-the-spot troubleshooting or comprehensive drive design, Drive Engineer delivers robust results:

- Complete belt details with part numbers
- Complete pulley specifications with part numbers and list prices
- Complete drive output details
- Full list of recommended drives
- Easy to save and share results
- Desktop & Mobile-Friendly - available for Apple® iOS and Android™ devices

Drive Engineer facilitates both new drive selection as well as existing drive analysis. Information provided includes horsepower capacity, drive limit warnings, service factors, pricing, hub loads, bushings, diameters, center distance and tensioning - everything needed to design a maximum-efficiency belt drive system.

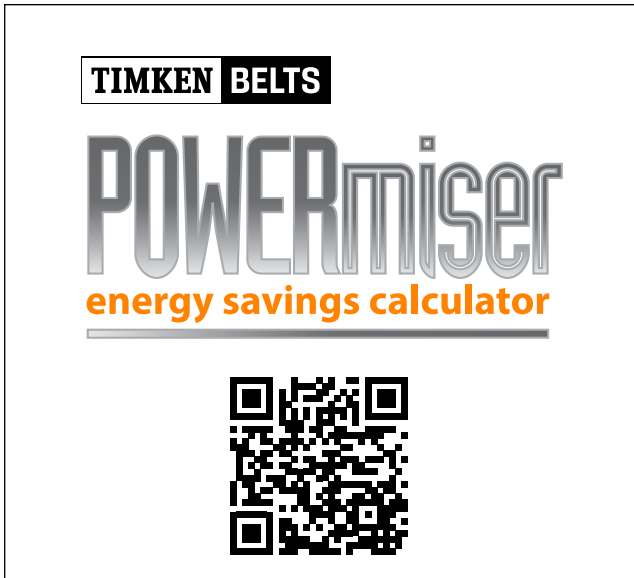

PowerMiser

Energy Savings Calculator Web App

The PowerMiser™ web app is a powerful, but simple energy savings calculator that can be accessed within the Drive Engineer® web app or saved as a separate application on your desktop or mobile device.

Calculate Energy Savings in 3 Easy Steps:

1. Enter the basic parameters of your belt drive system
2. Plug in your local utility rate
3. Select an energy efficient Timken belt

Instantly see estimated annual energy costs, savings and payback!

Go to powermiser.driveengineer.com or scan the QR code provided



Industrial V-Belt Drives Service Manual

Proper belt tensioning and alignment are important for energy efficiency and drive life. Consult the "Industrial V-Belt Drives Service Manual" for helpful tips on proper installation and maintenance of belt drives. .

Download from the resources section of our website at www.TimkenBelts.com or Drive Engineer or scan the QR code provided.

TENSION-FINDER®



It's practical!
It's reusable!
It's easy!
It works!

Tension-Finder® V-Belt Tensioning Device

V-Belt Tensioning Device
Part Number 108039-A

Eliminate your tensioning headaches with the "Tension-Finder®"—a simple, easy and accurate alternative for tensioning individual v-belts or bands.

- No measurements
- No math
- No computers
- No o-rings

NOTE: The Tension-Finder is designed for use with Timken belts. Do not use on belts with aramid, glass or carbon fiber cord.



Classical Belts

A, B, C, D, A-R, B-R, C-R, AX, BX, CX, DX, RB, RC, RD, RBX, RCX

Wedge Belts

3V, 5V, 8V, 3VX, 5VX, 8VX, SPZ, SPA, SPB, SPC, XPZ, XPA, XPB, XPC, R3V, R5V, R8V, R3VX, R5VX

Tension-Finder Jr. Tensioning Device

V-Belt Tensioning Device
Part Number 109081

Tension-Finder Jr. is a quick, easy and accurate device for tensioning new v-belts or bands. It's half the size of the Tension-Finder for use on smaller drives and HVAC applications. Proper tensioning is necessary for long, satisfactory operation of any belt drive. Tension-Finder Jr. can be used to tension new classical and wedge v-belts

NOTE: Tension-Finder Jr. is designed for use with Timken belts. Do not use on belts with aramid, glass or carbon fiber cord.

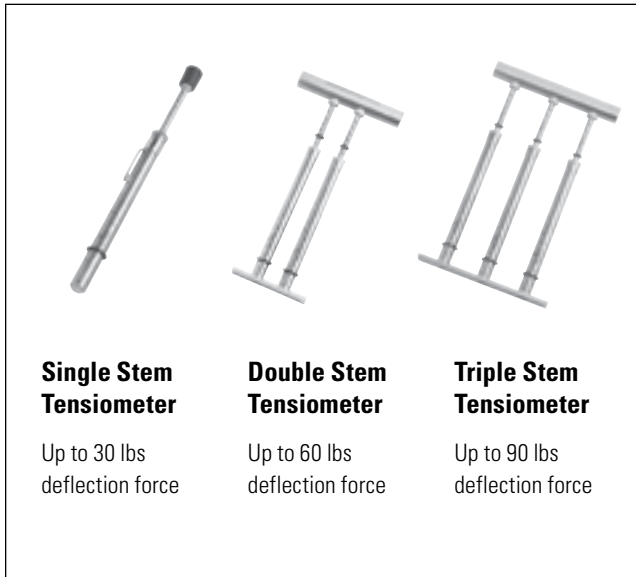

Spring-Loaded Tensiometer

Belt Tensioning Device

Single Stem

Part Number 102761

Double Stem

Part Number 105575

Triple Stem

Part Number 105576

Proper belt tensioning is one of the most important factors for satisfactory operation and long service life. Too little tension will result in slippage, causing rapid belt and sheave wear. Too much tension can result in excessive stress on the belts, bearings, and shafts.

The force required to deflect a span length by a given amount is related to the tension in the belt. The tensiometer measures that deflection. It can be used on v-belts, banded belts or synchronous belts.



Frequency-Finder

Belt Tensioning Device

Part Number 109061

The Frequency-Finder is an electronic instrument that precisely measures the frequency used to calculate the static tension in synchronous, v-belts, and v-ribbed belts. It displays the frequency on an LCD screen.

The Frequency-Finder works on the principle of forced vibration. The frequency of vibration is related to the tension of the belt, i.e. the higher the frequency reading, the higher the belt tension.

- Measures the natural frequency of vibration in the belt span
- Simple, fast, repeatable and reliable
- Can be used on any type of belt



Laser-Align

Laser Alignment Device
Part Number 109083

Laser-Align is a tool for fast and accurate alignment of belt drive pulleys. Laser-Align is magnetically mounted against the side of one of the pulleys and two magnetic targets are placed against the top, bottom or side of the opposite pulley. The laser projects from the end of the tool onto the targets allowing the user to quickly correct all types of misalignment between the pulleys. Only one person is needed to align the drive.

Along with proper tensioning, alignment is critical to satisfactory belt life and performance. A properly aligned drive reduces wear and vibration while increasing belt life and energy savings.

Extra Target for Laser-Align
Part Number 109083T

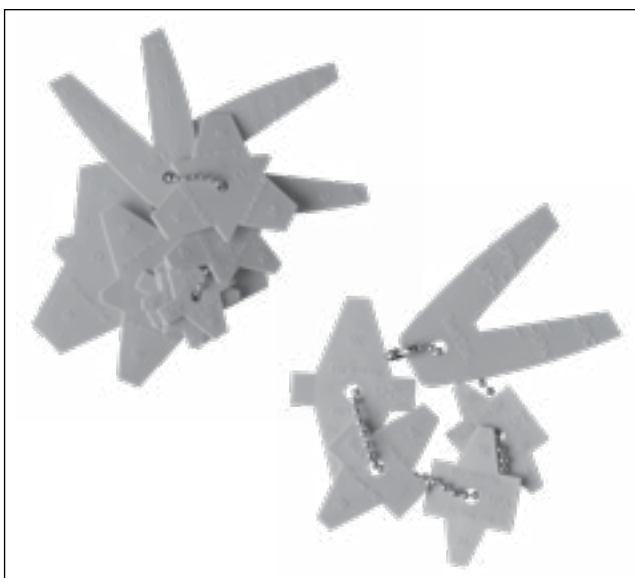

Sheave Gauges

Templates to check sheave wear
Imperial Set - Part Number 102495
Metric Set - Part Number 102496

Sheave condition and alignment are vital to v-belt life and performance. New v-belts should never be installed without a thorough inspection of the sheaves. Particular attention should be given to wobbling sheaves, a shiny groove bottom and worn groove sidewalls.

Use the sheave gauge to accurately check grooves for wear. A flashlight held behind the template, when placed in the groove, will help you observe the amount of wear. Wear should not exceed 1/32" for individual v-belt drives and 1/64" for banded belt drives.

Sheave gauges are based upon the standards for classical belts from the Association for Rubber Products Manufacturers ARPM IP-20, wedge belts ARPM IP-22 and metric belts ISO 4183.



Belt-Finder

Belt Measuring Device

Part Number 93859

The Belt-Finder is used to measure multiple types of v-belts and to help identify the correct replacement belt needed. A quick check shows the top width and length of classical (A, AX and B, BX) belts), wedge (3V, 3VX and 5V, 5VX) and FHP (3L, 4L, and 5L) belts. The Belt-Finder measures belts up to 100 inches in length.



Wallboard

Belt Merchandising Display

Part Number 93899

A popular inventory and display system for v-belts. One box includes 10 boards and 80 hooks. Each board is 36 inches long. The standard 6-inch hooks extend 5-3/8 inches. Extra hooks come in boxes of 25.

6-inch hooks, box of 25

8-inch hooks, box of 25

12-inch hooks, box of 25

Part Number 93899-H6

Part Number 93899-H8

Part Number 93899-H12

Reduce maintenance and downtime with RunRight®

When you need to reduce maintenance and downtime, choose Lovejoy® RunRight Motor Bases and Belt and Chain Tensioners. The design makes them well suited for the toughest applications, reducing the shock loads along with hard stops and starts protecting and extending the life of all surrounding equipment. When using lubrication-free RunRight products, retensioning is eliminated.

RunRight Motor Bases

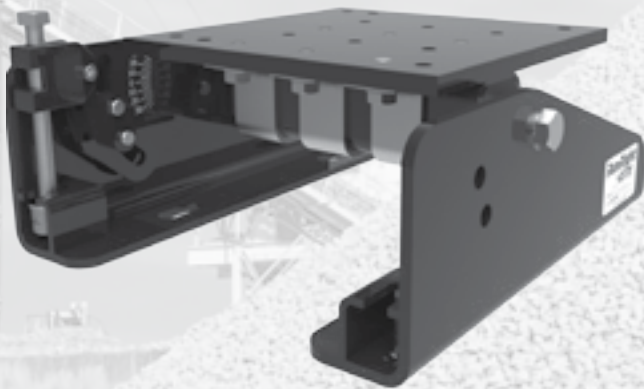

Provides constant torque transmission with less energy consumption and increase the life of your drive system

- Sixteen standard motor bases for NEMA frames 143T to 5810 and IEC frames 90S thru 315M
- Handles motors 1/2 to 700 HP

AGGREGATE & MINING

PULP & PAPER

STEEL

WASTEWATER

FOOD

RunRight Tensioners

Extend the life of belts and chains by applying a constant tension on the drive system

- Self adjusting/tensioning, easy to install
- Fits all chain sizes up to 120 single chain and C size belts 360° positioning flexibility
- Available in 7 stock sizes (4 sizes in stainless steel)



APPLICATIONS



Belt & Chain Drives



Indoor & Outdoor



High Contaminants/Oil

RunRight®
by **Lovejoy**

Notes

General Information

Synchronous Belt Drive Troubleshooting Guide

Synchronous Belts

V- Belts

Specialty Belts

Tools

General Information

Type of Failure	Cause of Failure	Corrective Action
Excessive edge wear (exposed tensile member)	Misalignment or non-rigid centers	Check alignment and/or reinforce mounting
	Belt flange	Straighten flange
Jacket wear on pressure-face side of belt tooth	Excessive overload and/or incorrect tension	Change installation tension and/or increase drive load carrying capacity
Excessive jacket wear between belt teeth (exposed tension members)	Excessive installation tension	Reduce installation tension
Cracks in backing	Exposure to excessive low temp (below -30°F)	Eliminate low temperature condition or consult factory for proper belt construction
	Chemical exposure	
Softening of backing	Chemical and/or oil	Eliminate oil condition or consult factory for proper belt construction
Excessive sprocket tooth wear (on pressure-face and/or OD)	Excessive overload and/or excessive belt tightness	Reduce installation tension and/or increase drive load-carrying capacity
	Insufficient hardness of sprocket material	Surface harden sprocket or use harder material
	Normal wear/end-of-service/grit or debris	Replace sprockets
Unmounting of flange	Incorrect flange installation	Reinstall flange correctly
	Misalignment	Correct alignment
Excessive drive noise*	Misalignment	Correct alignment
	Excessive installation tension	Reduce tension
	Excessive load	Increase drive load-carrying capacity
	Sub-minimum sprocket diameter	Increase sprocket diameters
	High speeds	Slow drives down
Tooth shear	Less than 6 teeth in mesh (TIM)	Increase TIM or use next smaller pitch
	Excessive load	Increase drive load-carrying capacity
	Low tension	Increase tension
Apparent belt stretch	Reduction of center distance or non-rigid mounting	Re-tention drive and/or reinforce mounting
Cracks or premature wear at belt tooth root	Improper sprocket groove top radius	Re-groove or install new sprockets
	Low tension	Increase tension
Tensile break	Excessive load	Increase load-carrying capacity of drive
	Sub-minimum sprocket diameter	Increase sprocket diameters

*NOTE: Effective noise reduction for power transmission drives can be accomplished by incorporating a flexible noise absorbing material with the protective guard. The guard design must allow a cooling air passage on the top and bottom to prevent overheating the drive.

General Information

V-Belt Troubleshooting Guide

Some of the more common symptoms of short v-belt life are listed in the chart below. This chart is intended to help identify the cause(s) of the problem so appropriate corrective action can be addressed and corrected. For more information on proper v-belt installation and maintenance, request the "Service Manual for Industrial V-Belt Drives" from your local distributor of Timken belts. It is also available at www.timkenbelts.com/resources or by simply scanning the QR code.

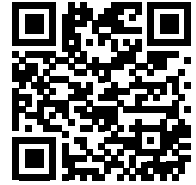

Symptoms	Belts pried on or misplaced slack	Belts rubbing guard	Sheaves misaligned	Worn or damaged sheaves	Sheaves too far from bearing	Poor bearing or shaft condition	Insufficient tension	Excessive tension	Improper sheave installation	Belts worn (normal service life)	Wrong belt cross-section or type	Mismatched belts or mixed brands	Machine-induced impulse or shock	Improper or prolonged storage	Excessive heat	Excessive oil or grease	Use of belt dressing	Abrasive environment	Foreign objects in grooves	Excessive moisture	Overloaded drive/underbelting	Drive seriously overbelted	Sheaves too small	Insufficient wrap on small sheave	Backside idler	Harmonics
Rapid sidewall wear		■	■	■			■				■	■		■	■	■	■	■		■	■					
Worn cover on back		■																						■		
Belt turns over or jumps off sheave	■	■	■				■		■		■								■						■	
Belt soft, swollen																■	■									
Belt slips, squeals (spin burn)	■			■			■		■	■	■	■			■	■	■				■	■		■		
Belt cover split	■																		■							
Underside cracked				■			■	■		■				■	■								■	■	■	
Tie-band damaged		■	■	■							■								■							
Snub break	■							■	■			■	■						■		■					
Belts ride too high											■															
Belts bottoming				■					■	■						■	■	■								
Repeated take-up necessary	■			■			■			■		■			■	■	■				■					
Belts vibrate excessively or appear mismatched	■		■	■			■		■		■		■									■			■	
Bearings are hot				■	■	■		■							■							■	■			
Shafts whip or bend				■	■	■		■	■													■	■			
Cracked bushings				■						■																
Sheave wobble				■		■		■	■																	

■ Indicates most common causes ■ Indicates other possible causes

General Information

Recommended Sheave & Idler Diameters & Proper V-Belt Storage

V-Belt Cross Section	Minimum P.D. Sheave or Inside Idler	Minimum O.D. Flat Backside Idler*
A	3.0	4.5
B	5.0	7.5
C	9.0	13.5
D	13.0	19.5
E	21.0	31.5
AX	2.6	4.0
BX	4.0	6.0
CX	7.0	10.5
DX	11.0	16.5
3V	2.6	—
3VX	2.2	—
5V	7.0	—
5VX	4.3	—
8V	12.4	—
8VX	11.2	—

Minimum Recommended Sheave and Idler Diameters

Belt Cross Section	Belt Length (inches)	Number of Coilings*	Number of Loops*
A, AA, 3V, and B	Under 60.0	None	1
	60.0 to 120.0	1	3
	120.0 to 180.0	2	5
	180.0 and up	3	7
BB, C, and 5V	Under 75.0	None	1
	75.0 to 144.0	1	3
	144.0 to 240.0	2	5
	240.0 and up	3	7
D	Under 120.0	None	1
	120.0 to 240.0	1	3
	240.0 to 330.00	2	5
	330.0 to 420.0	3	7
	420.0 and up	4	9
E and 8V	Under 180.0	None	1
	180.0 to 270.0	1	3
	270.0 to 390.00	2	5
	390.0 to 480.0	3	7
	480.0 and up	4	9

Proper V-Belt Storage Guide

Maximum Number of Coilings for V-Belts Stored on Hooks

Improper or prolonged storage can reduce service life considerably. V-belts should be stored in a cool, dry place with no direct sunlight. If stored on pegs, the longer belts should be coiled in loops of suitable size to prevent distortion from the weight of the belt.

The table on the left, provided by the Association for Rubber Products Manufacturers (ARPM), should be followed for optimum conditions.

*One coiling results in three loops; two coilings result in five loops, etc.

General Information

Brand Name Interchange

Belt Type/Cross Section	Timken Belts	Bando®	Browning® (Regal®)
Extreme Torque Synchronous 8M, 14M	‡ PantherXT (Part # example: 14MXT-994-20)	King Power (KPS II) (STPD sprockets only)	HPT Chain
High Torque Synchronous 8M, 14M, 20M	Panther (* RPP profile) (Part # example: 960-8MPT-20)	High Performance STS (STPD sprockets only)	HPT Plus
HTD Synchronous 3M, 5M, 8M, 14M	Syncho-Cog HT (Part # example: 600-8M-50)	Syncho-Link STS (STPD sprockets only)	HPT
Dual Sided Curvilinear D8M, D14M	Dual Synchronous (Part # example: D950-8M-50)		—
Timing Belt (Trapezoidal) XL, L, H, XH, XXH	Syncho-Cog Timing Belt (Part # example: 770XL025)	Syncho-Link Timing Belt	Gearbelt
Dual Sided Timing DXL, DL, DH	Dual Syncho-Cog® Timing Belt (Part # example: D770XL025)	Syncho-Link Double Sided	Double Gearbelt
Classical Raw Edge Cogged AX, BX, CX, DX	Gold-Ribbon Cog-Belt (Part # example: BX85)	Power King Cog (Part # example: BX85)	Gripnotch (Part # example: BX85)
Classical Raw Edge A-R, B-R, C-R	Super II V-Belt (Part # example: B85R)	—	—
Classical Wrapped A, B, C, D, E	Super Blue Ribbon V-Belt (Part # example: B85)	Power King (Part # example: B85)	Super Gripbelt (Part # example: B85)
Narrow Cogged 3VX, 5VX, 8VX	Power-Wedge Cog-Belt (Part # example: 5VX850)	Power Ace Cog (Part # example: 5VX850)	358 Gripnotch (Part # example: 5VX850)
Narrow 3V, 5V, 8V	Super Power-Wedge (Part # example: 5V850)	Power Ace (Part # example: 5V850)	358 Gripbelt (Part # example: 5V850)
Double-V Hexagonal AA, BB, CC	Double Angle V-Belt (Part # example: BB75)	Double V (Part # example: BB75)	Double-V Gripbelt (Part # example: BB75)
V-Ribbed J	Vee-Rib (Part # example: 490J8)	Rib Ace (Part # example: 490J8)	Poly-V (Part # example: 490J8)
Variable Speed	Variable Speed Cog-Belt (Part # example: 2322V721)	Power Max	V-S Belt
Classical Cogged Banded RBX, RCX	Gold-Ribbon Cog-Band (Part # example: RBX85-3)	Power King Cog Combo	Gripband (Part # example: 3GBBX85)
Narrow Cogged Banded R3VX, R5VX	Power-Wedge Cog-Band (Part # example: R5VX850-3)	Power Ace Cog Combo	—
Narrow Banded R3V, R5V, R8V	Power-Wedge Band (Part # example: R5V850-3)	Power Ace Combo	358 Gripband (Part # example: 3GB5V850)
Classical Banded RB, RC, RD	Super Blue Ribbon Band (Part # example: RB85-3)	Power King Combo	Gripband (Part # example: 3GBB85)
Light-Duty FHP 2L, 3L, 4L, 5L	Durapower II (Part # example: 4L400R)	Duraflex GL	FHP (Part # example: 4L400)

* RPP profile is interchangeable with HTS, PGGT2, HPPD, Hawk and HTD sprockets.

‡ Use Martin MPC® or drop into existing Poly Chain® GT*2 sprockets – not interchangeable with RPP sprockets.

Note: Product names are trademarks of their respective companies.

General Information

Brand Name Interchange

ContiTech®	Gates®	Jason® (Megadyne®)	MBL®
SynchroChain Carbon or Falcon Pd (Part # example: CTD14M-994-20, 14GTR-994-20)	Poly Chain GT Carbon (Part # example: 14MGT-994-20)	RPP Platinum	GigaTorque
BlackHawk Pd (Part # example: 960 8MBH 20)	Power Grip GT2 (Part # example: 960-8MGT-20)	Tiger	
Hawk Pd	Power Grip GT HTD (Part # example: 600-8M-50)	HTB (HTD)	High Torque Timing
Dual Hi-Performance Pd	GT2 Twin Power (Part # example: TP950-8MGT-50)	Dual HTB (HTD)	
Positive Drive	Power Grip (Part # example: 770XL025)	Standard Timing	Three Stars Timing
Dual Positive Drive	Power Grip Twin Power	Dual Timing	Three Stars Dual Timing
Torque Flex (Part # example: BX85)	Tri-PowerMolded Notch (Part # example: BX85)	Uni-Match Cogged (Part # example: BX85)	Raw Edge Cogged (Part # example: BX85)
—	—	—	—
HY-T (Part # example: B85)	Hi-Power II (Part # example: B85)	Uni-Match (Part # example: B85)	Conventional (Part # example: B85)
HY-T Wedge Cog (Part # example: 5VX850)	Super HC Molded Notch (Part # example: 5VX850)	Uni-Match cogged (Part # example: 5VX850)	Maxstar Wedge Supreme (Part # example: 5VX850)
HY-T Wedge (Part # example: 5V850)	Super HC (Part # example: 5V850)	Uni-Match Deep Wedge (Part # example: 5V850)	Maxstar Wedge (Part # example: 5V850)
Hex (Part # example: BB75)	Hi-Power II Double V (Part # example: BB75)	Double Multiple V-Belt (Part # example: BB75)	Double (Part # example: BB75)
Poly-V (Part # example: 490J8)	Micro-V (Part # example: 490J8)	Multi-Rib (Part # example: 490J8)	Ribstar (Part # example: 490J8)
Variable Speed	Multi-Speed	Variable Speed	Vari-Star
Torque Team Cogged (Part # example: 3/BX85)	Tri-Power Molded Notch (Part # example: 3/BX85)	Uni-Match	
—	—	—	—
HY-T Wedge Torque Team (Part # example: 3/5V850)	Super HC Power Band (Part # example: 3/5V850)	Uni-Match Wedge Banded (Part # example: R5V850-3)	
HY-T Torque Team (Part # example: 3/B85)	Hi-Power II Power Band (Part # example: 3/B85)		Conventional Banded
FHP (Part # example: 4L400)	Truflex **(Part # example: 2400)	FHP	FHP

** The part number consists of a prefix and a length designation. Prefixes: 2L = 0, 3L = 1, 4L = 2, 5L = 3

General Information

Brand Name Interchange – Continued

Belt Type/Cross Section	Optibelt®	PIX®	Thermoid®	TB Woods®
Extra High Torque Synchronous 8M, 14M		—	—	QT PowerChain® II GT2 tooth profile
High Torque Synchronous 8M, 14M, 20M	Omega HP	Pix-X'act HP	—	
HTD Synchronous 3M, 5M, 8M, 14M	Omega HL	Pix-X'act HTD	Grip-Tite HT	Synchronous Plus (Part # example: 600-8M-50)
Dual Sided Curvilinear D8M, D14M	—	—	—	Twin Power (Part # example: TP950-8M-50)
Timing Belt (Trapezoidal) XL, L, H, XH, XXH	Timing Belt ZR	Pix-X'act CT	Grip-Tite Timing	Sure Grip Timing (Part # example: 770XL025)
Dual Sided Timing DXL, DL, DH	Double Timing ZRD	—	Grip-Tite Dual Timing	Twin Power Timing (Part # example: TP770XL025)
Classical Raw Edge Cogged AX, BX, CX, DX	Optibelt Super TX M-S (Part # example: BX85)	Pix-X'tra cogged (Part # example: BX85)	Prime Mover Cogged (Part # example: BX85)	Torque Flex II (Part # example: BX85)
Raw Edge Classical A,B,C	—	—	—	—
Classical Wrapped A, B, C, D, E	VB (Part # example: B85)	Pix-X'set Classical (Part # example: B85)	Prime Mover (Part # example: B85)	Sure Grip (Part # example: BP85)
Narrow Cogged 3VX, 5VX, 8VX	Super TX M=S (Part # example: 5VX850)	Pix-X'tra cogged wedge (Part # example: 5VX850)	Maxipower Cogged (Part # example: 5VX850)	Ultra-V Cog (Part # example: 5VX850)
Narrow 5V, 8V	Optibelt SK (Part # example: 5V850)	Pix-X'set Narrow (Part # example: 5V850)	Maxipower (Part # example: 5V850)	Ultra-V (Part # example: 5V850)
Double-V Hexagonal AA, BB, CC	Optibelt DK (Part # example: BB75)	Pix-X'set DS Hexagonal (Part # example: BB75)	Hex Double V (Part # example: BB75)	Double-V (Hex) (Part # example: BB75)
V-Ribbed J	Ribbed Belt RB (Part # example: 490J8)	PIX-X'ceed (Part # example: 490J8)	Multi-Ribbed (Part # example: 490J8)	Poly-V (Part # example: 490J8)
Variable Speed	Super VX	Pix-X'tra VS	Variable Speed	Variable Speed (Part # example: 2322V721)
Classical Cogged Banded RBX, RCX, RDX, RBL, RCL, RDL	Kraftbands KBX			Cog Flex Banded (Part # example: 3RBX85)
Narrow Cogged Banded R3VX, R5VX	—	Pix-X'tra MB Cogged Banded	—	Ultra-V Cog Banded (Part # example: 3R5VX850)
Narrow Banded R3V, R5V, R8V	Kraftbands KB	Pix-X'Set MB Wedge Banded	Maxi-Power Band (Part # example: 5V850/3)	Ultra-V Band (Part # example: 3R5V850)
Classical Banded RB, RC, RD	Kraftband	Pix-X'Set MB Banded	Prime Mover Banded (Part # example: B85/3)	Sure Grip Banded (Part # example: 3RBP85)
Light-Duty FHP 2L, 3L, 4L, 5L	Optibelt LD	Pix Light Duty	Glasstex (Part # example: 4L400)	Light-Duty FHP (Part # example: 4L400)

Bando® is a registered trademark of Bando Chemical Industries, Ltd. Optibelt® is a registered trademark of the OPTIBELT Corporation. PIX® is a registered trademark of Pix Transmissions Limited. Thermoid® is a registered trademark of HBD/Thermoid, Inc. TB Woods® is a registered trademark of Altra Industrial Motion Corp. Browning® is a registered trademark of Regal Beloit America, Inc. ContiTech® is a registered trademark of ContiTech AG. Gates®, PowerGrip®, HTD® and GT® are registered trademarks of Gates Corporation. Jason® is a registered trademark of Jason Industrial, Inc. Megadyne® is a registered trademark of Megadyne S.p.A. MBL® is a registered trademark of Mitsubishi Belting Ltd. Martin® MPC® are registered trademarks of Martin Sprocket & Gear, Inc. Product names are trademarks of their respective companies.

ARPM	The Association for Rubber Products Manufacturers (ARPM) was established in 2010 after elastomer products companies belonging to the Rubber Manufacturers Association (RMA) mutually agreed that a stand-alone association was needed.
ACHE Synchronous Belt	Timken Air-Cooled Heat Exchanger (ACHE) synchronous belts are constructed using only “Z” twist cord to provide upward direction of lateral movement on vertical shaft drives. This special construction reduces wear on the bottom side of the belt. Available in 14M cross sections.
Anti-Static	Anti-static is a term used to describe materials that prevent the buildup of static electricity.
Anti-Static Belt	Under certain conditions of temperature and humidity, a belt drive may generate static electricity. Belts intended for operation in a potentially dangerous atmosphere should be constructed with a relatively low electrical resistance characteristic. It is common to specify and refer to such belts as “static conductive”, “static dissipating”, or “anti-static”. Most Timken v-belts are static dissipating.
Aramax® Power-Wedge® V-Belt	Timken high performance narrow v-belt designed for extraordinary belt strength on the toughest drives. Aramid cord provides high horsepower capability. Available in 5VK, 8VK, SPBK and SPCK cross sections.
Aramax® Power-Wedge® Band	Banded version of Timken Aramax Super Power-Wedge belt designed for extraordinary strength on the toughest drives. It's ideally suited for oil field mud pumps, rock and quarry applications, lumber industry drives and heavy construction machinery. Available in R5VK, R8VK, RSPBK and RSPCK cross sections.
Aramax® Xtra Duty V-Belt	Timken Aramax XDV is a heavy duty v-belt made with Aramid cord and a brown smooth clutching cover. Aramax v-belts are designed for outdoor power equipment and other shock loaded, backside-idler driven equipment. The high performance construction delivers more horsepower, less stretch and long service life. Available in 3L, A and B cross sections.
Aramid Cord	Aramid is a class of heat-resistant and very strong synthetic fibers. Aramid is stronger than steel. It's used as a tensile member that is available in several lines of Timken belts. Aramid is often referred to as Kevlar® which is a trademark of DuPont.
Band	Two or more v-belts (ribs) that are permanently joined together at the top with a reinforced tie-band. Banded belts assure that each rib is sharing the load equally to achieve the full horsepower capacity of the drive. Used on pulsating or heavily shock loaded drives and drives with long center distances to minimize belt whip and rollover. Also known as joined belts.
Belt	A loop of flexible material placed around two or more pulleys or sheaves, for the purpose of transmitting motion, power, or materials from one point to another.

Belt Drive	An assembly of one or more belts, sheaves or pulleys and the means for securing the sheaves or pulleys to shafts, for the purpose of transmitting motion, power or materials from one point to another.
Belt Finder Tool	Timken belt measuring device that helps identify the correct replacement belt. The Belt Finder measures the top width and length on classical A, AX, B, BX section v-belts, FHP 3L, 4L, 5L and wedge belts with 3V, 3VX, 5V, 5VX cross sections.
Brand	A mark or symbol identifying the product and manufacturer. On all Timken belts, the brand identifies the part number, product name and product characteristics.
Bushings	A hub system that allows adaptation of sheaves, pulleys and sprockets to varying shaft sizes. Common bushing systems are QD, Taper-Lock and MST.
Carbon Cord	Carbon cord provides strength, flex fatigue resistance, dimensional stability and high power density. The exceptional strength-to-weight ratio of carbon fiber make it ideal for some applications.
CEMA	Conveyor Equipment Manufacturers Association
Center-to-Center	The distance from the center of one pulley to the center of the opposite pulley. Also called center distance.
Chek Mate®	Chek Mate is a Timken process that manufactures belts to meet or exceed the Association for Rubber Products Manufacturers tolerances for a matched set. Matching numbers are not required on Super Blue Ribbon, Super II, Super Power-Wedge, Power-Wedge Cog-Belt and Gold-Ribbon Cog-Belt which all carry the distinctive Chek Mate logo.
Chipper Drive Wedge-Band®	Timken laminated banded belt made of EPDM that is specially designed and constructed to meet the unique demands of the lumber industry. EPDM is durable and resistant to oil, heat, hardening and glazing with superior flex and load carrying capacity and a broad operating temperature range of -50°F to +250°F. The tie-band is highly engineered to permanently bond multiple belts together enabling the belts to function as a single unit with even load distribution and wear. Banded belt construction minimizes belt whip and rollover on long center distance drives. Available in 5V cross section.
Classical V-Belt	The classical v-belt profile dates back to industry standards developed in the 1930s. Cross sections include A, B, C, D and E.
CNA	Central Neutral Axis (CNA) cord placement positions the strength of the belt lower in the sheaves to maintain stability and flexibility. Examples of Timken belts with a CNA construction are Super II and Durapower II v-belts.
Cog	Some v-belts have cogs that reduce bending stress. Cogs are different than the teeth of a synchronous (timing or positive-drive) belt which require the use of mating sprockets.

Glossary

Cog-Band®	Timken trademarked name for a banded v-belt with cogs. Precision molded cogs reduce bending stress. Banded belts minimize belt whip and rollover on long center distance drives.
Cog-Belt®	Timken trademarked name for a v-belt with cogs. We invented the raw edge cog-belt in 1926. Cogs reduce bending stress and allow use on small diameter sheaves. Cog-Belts are used with the same sheaves as equivalently rated v-belts. Also called cogged or notched v-belts.
Compound	The mixture of rubber polymers and other materials which are combined to give the desired properties when used to form the body of the belt.
Compression Section of V-Belt	Made of synthetic rubber compounds, the compression section of the belt is developed to support the cords evenly and compress while bending around the sheaves.
Cord	The tensile cord is the load bearing element of the belt. High-modulus synthetic fiber cords carry the horsepower load and minimize stretching. Most belts use polyester, fiberglass, aramid or carbon fiber cord.
Cotton Drive® Timing Belt	Timken Cotton Drive belts are special one inch pitch timing belts designed for cotton gin drives. Cotton Drive timing belts are uniquely constructed for optimum performance on this harsh application.
Cover	The outer component of a wrapped molded v-belt. The Timken belt cover is made of a heavy duty fabric impregnated with rubber that protects the core of the belt.
Cover Wear	The loss of material during use due to abrasion, cutting, or gouging.
Cracking	A sharp break or fissure in the surface of a belt.
Date Code	A combination of numbers, letters or symbols used to identify when a product was manufactured. Timken belts use a four digit code to identify the week and year of manufacture. For example, 1019 means the belt was made the tenth week of 2019.
Double Angle V-Belt	Timken double angle v-belts are hexagonal belts designed for drives where power needs to be transmitted equally from both sides of the belt. Available in AA, BB and CC cross sections.
Drive	In power transmission, an assembly of components designed to give motion to a machine or machine part.
Drive Engineer®	Drive Engineer is a web app that facilitates both new drive selection as well as existing drive analysis on your desktop or mobile device. Information provided includes horsepower capacity, drive limit warnings, service factors, hub loads, bushings, diameters, center distance and tensioning - everything needed to design a maximum-efficiency belt drive system. Drive Engineer selects two-pulley drive systems based on standard line products offered by Timken Belts.

Drive Horsepower	The power rating of a specific drive.
Dry Can Belt	Timken Dry Can belts are designed with deep-groove notches specifically developed for double angle "CC" drives commonly found in the textile industry. The deep groove minimizes belt rollover while the notches provide added flexibility and long belt life.
Dual RPP® Synchronous Belt	Timken double sided curvilinear synchronous belt with RRP profile that delivers 100% load capacity on both sides of the belt. Available in 8M and 14M tooth profiles.
Dual Synchro-Cog® Timing Belt	Timken double sided timing belt with a trapezoidal tooth profile that provides synchronization and 100% load capacity from both sides of the belt. Available in XL, L and H tooth profiles.
Durapower® II FHP V-Belt	Timken light duty v-belt designed for fractional horsepower (FHP) applications. Durapower II v-belts combine the advantages of EPDM, raw edge technology, and CNA construction for superior performance and efficiency. Available in 2L-R, 3L-R, 4L-R and 5L-R cross sections.
Effective Diameter	The diameter of the pulley at the effective width of the pulley groove.
Effective Length	Effective Length (E.L.) is a standard length measurement that accounts for varying construction and manufacturing methods in the industry. The length is determined by adding the effective circumference to twice the measured center distance using sheaves and an applied tension specified by the ARPM.
EPDM	Ethylene Propylene Diene Monomer (EPDM) is a synthetic rubber that is durable and resistant to oil, heat, hardening and glazing. Timken belts made of EPDM have superior flex and load carrying capacity with a broad operating temperature range of -50°F to +250°F.
Face	The outer surface of a pulley. Also the outer surface of a synchronous belt tooth.
Feather Picker V-Belt	Timken double angle cog-belt that provides superior performance on poultry processing equipment. Engineered for flexibility and enhanced grip in moist conditions. Available in AAX and BBX sizes.
FHP	Fractional HorsePower. Fractional indicates that the motor has a power rating smaller than one horsepower. Durapower II v-belts are designed for FHP applications.
Flex Life	The ability of a belt to withstand cyclical bending stresses.
Flour Power™ Roller Mill Belt	Timken specialty belt engineered for automated milling machines. Roller mill drive belts are typically dual sided. Some are constructed as a dual synchronous or dual v-ribbed belt, while others feature a high torque synchronous belt on one side with v-ribbed capability on the other.

Frequency-Finder Tensioning Tool	The Timken Frequency-Finder is an electronic instrument that measures the frequency used to calculate the static tension in various types of belts. The tool is fast, repeatable and reliable.
Gold-Ribbon® Cog-Band®	Banded version of Timken Gold-Ribbon Cog-Belt. Available in RBX and RCX cross sections. Banded belts assure that each rib is sharing the load equally to achieve the full horsepower capacity of the drive. Ideally suited for pulsating or heavily shock loaded drives and drives with long center distances to minimize belt whip and rollover.
Gold-Ribbon® Cog-Belt®	Timken energy saving classical raw edge cog-belt. The unique construction combines the superior flexing of precision molded cogs with the tenacious gripping power of raw edge sidewalls to provide higher energy efficiency, increased power ratings and longer belt life than wrapped v-belts. Gold-Ribbon Cog-Belts are made of EPDM that is durable, heat resistant, static conductive and resistant to hardening and glazing Available in AX, BX, CX, and DX cross sections
HARDI	HARDI (Heating, Air-conditioning and Refrigeration Distributors International) is an organization representing wholesale distribution within the HVACR industry.
Hexagonal V-Belt	Double angle v-belts designed for drives where power needs to be transmitted equally from both sides of the belt. Available in AA, BB and CC cross sections.
Horsepower	Horsepower (hp) is a unit of measurement of power, or the rate at which work is done. There are different standards and types of horsepower. In mechanical engineering, power is a measure of performance or capacity and is defined as the amount of work performed in a given time. Horsepower was originally defined as the power that a horse gives when pulling, or the power needed to move 33,000 pounds a distance of one foot in one minute.
HTD®	HTD means High Torque Drive. HTD belts were the first generation of curvilinear synchronous belts. HTD is a registered trademark of the Gates Corporation.
HVACR	Heating Ventilation Air Conditioning and Refrigeration. HVACR is one of the largest markets for belts.
ID	Inside diameter of the belt.
Idler	An adjustable free-wheeling pulley used to guide or apply tension to a belt.
Inside Length	The length as measured by the inside circumference of the belt.
ISO	International Standards Organization. Timken Belts manufacturing facilities and technical center are registered as compliant with the International Standard ISO 9001:2015. ISO certification ensures that organizations understand their key quality processes, that the processes are implemented and followed by everyone in the organization and that the processes are documented and maintained to a degree that they can be demonstrated to an outside agency.
Joined Belts	Joined or banded belts are two or more v-belts that are permanently joined together at the top with a tie-band. Joined belts assure that each rib is sharing the load equally to achieve the full horsepower capacity of the drive. Used on pulsating or heavily shock loaded drives and drives with long center distances to minimize belt whip and rollover.
Kevlar®	An aramid fiber used as a tensile member in belts. Kevlar is a trademark of DuPont.
Laser-Align Tool	Timken Laser-Align is a tool for fast and accurate alignment of belt drive pulleys. Along with proper tensioning, alignment is critical to satisfactory belt life and performance.
Lean Manufacturing	Lean is the set of "tools" that assist in the identification and elimination of waste. As waste is eliminated, quality improves while production time and cost is reduced.
Lean Sigma	The term combines two quality improvement approaches, Lean and Six Sigma. Lean methodologies focus on eliminating waste and streamlining processes. Six Sigma projects increase quality and yield while reducing defects and variation.
Matching (Belt Matching)	If belts are not the same dimensionally when used on a drive with multiple belts, they won't evenly distribute the load. Using belts that are not matched result in uneven belt wear, leading to premature failure. Timken belts with the Chek Mate symbol will match. (see SAG and Chek Mate)
Matching Tolerance	The acceptable limits on the difference in length for belts in a matched set as defined by the Association for Rubber Products Manufacturers. Timken belts with the Chek Mate symbol meet or exceed these tolerances and will match.
Metric Belts	Metric belts are manufactured to meet or exceed ISO (International Organization for Standardization) and DIN (Deutsches Institut für Normung - German Institute for Standardization) standards. Metric belts use different nomenclature and dimensions based in millimeters.

Glossary

Metric Power-Wedge® Cog-Belt®	Timken narrow wedge raw edge cogged v-belt in metric sizes. Combines the advantages of the narrow wedge design, EPDM and raw edge cog belt performance to maximize operating efficiency in a compact drive package. Available in XPZ, XPA, XPB and XPC cross sections.	Pitch Length	The length at the belt pitch line as measured at the pitch diameter of the sheave with the belt at a specified tension.
MOQ	Minimum Order Quantity. When belts are made-to-order, a minimum order quantity is required.	Ply	A layer of a belt.
MPTA	The Mechanical Power Transmission Association was founded in 1933. MPTA was one of the first organizations in the power transmission field to launch programs of standardization.	Poly-V® Belt	Common name for a v-ribbed belt. Is often referred to with the cross section, for example PVJ. Poly-V is a trademark of Conti-Tech. Timken v-ribbed belts are named Vee-Rib.
MSDS	Material Safety Data Sheet (MSDS) or Safety Data Sheet (SDS) is a document that lists information relating to occupational safety and health for the use of various substances and products.	PowerMiser Web App	PowerMiser is a web app that calculates estimated annual energy savings that can be gained by upgrading to energy efficient Timken belts.
MTO	Made-To-Order belts are custom made to specifications required by a customer for a unique application.	Power-Wedge® Cog-Band®	Banded version of Timken Power-Wedge Cog-Belt. Banded belts assure that each rib is sharing the load equally to achieve the full horsepower capacity of the drive. Ideally suited for pulsating or heavily shock loaded drives and drives with long center distances to minimize belt whip and rollover. Available in R3VX and R5VX cross sections.
MTS	Made-To-Stock belts are standard cataloged products.	Power-Wedge® Cog-Belt®	Timken narrow raw edge cog-belt. Combines the advantages of the narrow wedge profile, EPDM and raw edge cog belt performance to maximize operating efficiency in a compact drive package. Available in 3VX, 5VX and 8VX and metric XPZ, XPA, XPB and XPC cross sections.
Narrow V-Belt	Narrow (wedge) v-belts have more steeply angled sidewalls (greater depth to width ratio) providing increased wedging action and higher power ratings than classical v-belts. This allows operation over narrower pulleys to provide space-savings. Narrow profile belts by Timken are named Power-Wedge. Cross sections include 3V/3VX, 5V/5VX, 8V and metric SPZ/XPZ, SPA/XPA, SPB/XPB, SPC/XPC.	PT	Power Transmission is the movement of energy from its place of generation (motor) to a location (driven unit) where it is applied to perform useful work.
OC	Outside Circumference is the length as measured around the outside of the belt.	PTDA	Power Transmission Distributors Association (PTDA) is an association for the industrial power transmission/motion control (PT/MC) distribution channel.
OD	OD is the outside diameter of the pulley.	PTplace	Ptplace.com is an ecommerce website where distributors can place and track orders on line. PTplace.com is an easy, fast and accurate way to place orders electronically, check order status, check inventory availability and see customized pricing. Timken belts can be ordered from the Timken store on PTplace.com.
OEM	Original Equipment Manufacturer	Pulley	A pulley is a wheel with a grooved rim on an axle that is designed to support movement of a belt along its circumference to transmit power from one rotating shaft to another. A pulley is also called a sheave or sprocket. In general, use the term sprocket when referring to the metal used with synchronous belts. Sheaves have v-shaped grooves designed for use with various types of v-belts.
OHR	Oil and Heat Resistant. The belt will meet or exceed ARPM standards to withstand oil and heat.	Quarter Turn Drive	A belt drive in which the axis of the driver and driven sheaves or pulleys are at right angles to each other.
OPE	Outdoor Power Equipment. Lawn and garden equipment, mowers, tillers, snow throwers, etc.	Raw Edge	Raw edge v-belts are cured and then cut into a V shape. We invented the raw edge v-belt in 1921. The gripping power of raw edge sidewalls provides higher energy efficiency and reduces vibration for extended component life. The raw edge construction allows more cord width for increased horsepower capacity. Raw edge cog-belts run cooler, last longer, and have an efficiency that is about 2% higher than that of wrapped molded v-belts. Also called cut edge.
OPEAA	Outdoor Power Equipment Aftermarket Association		
OPEI	Outdoor Power Equipment Institute		
Panther® Synchronous Belt	Timken high torque synchronous belt with an RPP curvilinear tooth profile. Panther belts are designed to improve performance and drive life while reducing maintenance and downtime. Available in 8M, 14M, and 20M.		
Panther® XT Synchronous Belt	Timken extreme torque synchronous belt that can be used as an alternative to chain or drop-in replacement for high torque polyurethane belts. Panther XT is made with carbon cord and engineered to run in the harshest environments. Available in standard Poly Chain® lengths and widths.		

RMA	Rubber Manufacturers Association.		
Roller Mill Belt	Timken specialty belt engineered for automated milling machines. Roller mill drive belts are typically dual sided. Some are constructed as a dual synchronous or dual v-ribbed belt, while others feature a high torque synchronous belt on one side with v-ribbed capability on the other.		
Rotocure	Rotocure is a shortened name for Rotary Curing Press. This machinery is designed for the vulcanization of belts.		
Round Belt	Round belts are used on conveyors, quarter-turn, twisted, and serpentine drives. Timken round belts feature a no-splice construction for added durability with minimal stretch. Available in 7/16" and 9/16" diameters.		
RPM	Revolutions Per Minute. RPM is used as a measure of how fast a machine is operating at a given time.		
RPP®	Reinforced Parabolic Profile is a modified curvilinear synchronous belt tooth profile. RPP is interchangeable with HTS, PGGT™2, HPPD, and HTD® sprockets.		
Rubber	A material that is capable of recovering from large deformations quickly and forcibly. Rubber has been used for over 1000 years and once came entirely from natural sources. Synthetic rubber was introduced in the late 1940s. Timken Belts makes over 50 rubber polymers designed for specific applications.		
SAG	When multiple belts are used on a drive and all are not the same length, some belts may appear to hang unevenly or sag. Optimal drive performance requires "Matched Belts". A "SAG" number identifies variation from the nominal (target) specification. Some belts still utilize "SAG" numbers. Timken belts with the Chek Mate symbol will match. (See Chek Mate.)		
SBR	Styrene-Butadiene Rubber. A family of synthetic rubber derived from styrene and butadiene used in making some belts.		
SDS	Safety Data Sheet (SDS) or Material Safety Data Sheet (MSDS) is a document that lists information relating to occupational safety and health for the use of various substances and products.		
Service Factor	When designing belt drives, a service factor is added for demanding applications. The service factor accounts for the severe conditions of different types of applications and operating conditions. For example, drives with high shock loads can shorten the life of belts as well as bearings and other components. A multiplier is applied to the required horsepower of a drive to determine the design horsepower. It compensates for the extra life taken out of a belt during times that it operates above the required horsepower.	Service Factor Wizard	Drive Engineer takes the guess work out of determining the proper service factor with the Service Factor Wizard. Service factors provide more accurate drive requirements by considering the severity of different types of applications and operating conditions. When designing a synchronous or v-belt drive, use the service factor wizard to assure optimal performance and belt life.
		Sheave	A wheel with V shaped grooves designed to accommodate one or more v-belts. Also known as a pulley.
		Sheave Gauge	Set of templates to check sheave wear. Sheave condition and alignment are vital to v-belt life and performance. Available in imperial and metric sizes.
		Shock Load	Shock load is a stress created by a sudden force. Shock loading in belt drives occurs when an object suddenly accelerates or decelerates or when higher than normal intermittent or cyclic torque loads occur. Shock loads add stress to the belt and may lead to belt failure.
		Six Sigma	Six Sigma is a disciplined, statistical-based, data-driven continuous improvement methodology to systematically improve processes by eliminating defects.
		Sleeve	Timken Belts has two meanings for sleeve. 1. A cardboard sleeve is packaging that fits over the finished belt with part number, bar code and other information about the belt. 2. Belts are manufactured on a drum creating a sleeve that is then cut. Full factory width sleeves of synchronous belts can be purchased and then cut to the proper width as needed.
		Sprocket	A sprocket is a toothed wheel whose teeth engage with the belt. Positive engagement is dependent upon the meshing of the belt teeth with the mating grooves of the sprocket. Also called timing pulleys.
		Static Conductive/Dissipating	Having the capability of furnishing a path for the flow of static electricity.
		Static Conductive/Dissipating Belt	Under certain conditions of temperature and humidity, a belt drive may generate static electricity. Belts intended for operation in a potentially dangerous atmosphere should be constructed with a relatively low electrical resistance characteristic. It is common to specify and refer to such belts as "static conductive", "static dissipating", or "anti-static". Most Timken v-belts are static dissipating.
		Stiff-Flex	Timken Stiff-Flex is fiber loaded rubber that orients the fibers in one direction allowing cord support in the v-groove of the pulley while at the same time being flexible around the radius of the pulley.
		Super Arc™ Belt	Timken specialty heavy duty wrapped belt designed to provide improved flexibility, performance and extended belt life on live/power roller conveyor drives. Available in B cross section v-belts and 9/16 inch round belts.

Glossary

Super Blue Ribbon® V-Belt	Premium Timken wrapped molded v-belt built to the highest standards in the industry. Ideal for classical drives with shock loads. Available in A, B, C, D and E cross sections.	Synchronous Tooth Pitch	The spacing between two adjacent teeth on the belt (and sprocket). Measured from the center of one tooth to the center of the next tooth.
Super Blue Ribbon® Band (formerly Super Vee-Band®)	Banded version of Timken Super Blue Ribbon V-Belt. Banded belts assure that each rib is sharing the load equally to achieve the full horsepower capacity of the drive. Ideally suited for pulsating or heavily shock loaded drives and drives with long center distances to minimize belt whip and rollover. Available in RB, RC and RD cross sections.	Synchronous Tooth Profile	Indicates the type or shape of the belt tooth.
Super II® V-Belt	Timken classical laminated raw edge v-belt made of Ethylene Propylene Diene Monomer (EPDM) with a Central Neutral Axis (CNA) cord placement that creates a flexible, stable and efficient v-belt. EPDM is durable, heat resistant, static conductive and resistant to hardening and glazing. Available in A-R, B-R and C-R cross sections.	Take-up	The removal of slack or stretch from a belt.
Super Power-Wedge® V-Belt	Timken narrow wrapped molded v-belt for controlled power transfer. The stress-relieved wrapped cover provides superior wear resistance. The narrow cross section enables the design of a more compact drive. Available in 3V, 5V and 8V cross sections.	Teeth	The part of a synchronous belt that meshes with the grooves of the sprocket.
Super Power-Wedge® Band (formerly Wedge-Band®)	Banded version of the Timken Super Power-Wedge V-Belt. Minimizes belt whip and rollover on long center distance drives. Banded belts assure that each rib is sharing the load equally to achieve the full horsepower capacity of the drive. Ideally suited for pulsating or heavily shock loaded drives and drives with long center distances to minimize belt whip and rollover. Available in R3V, R5V and R8V cross sections.	Tensile Member	The tensile cord is the backbone and load bearing element of the belt. These cords provide strength, flex life and resistance to elongation. High-strength synthetic fiber cords carry the horsepower load and minimize stretching. Most belts use polyester, fiberglass, aramid or carbon fiber cord.
Synchro-Cog® HT Synchronous Belt	Curvilinear synchronous belt with HTD® profile. Available in 3M, 5M, 8M and 14M cross sections.	Tensiometer	Spring-loaded belt tensioning device. The force required to deflect a span length by a given amount is related to the tension in the belt. The tensiometer measures that deflection. This tool can be used on v-belts, banded belts or synchronous belts. Available in single, double and triple stem configurations.
Synchro-Cog® Timing Belt	Timken synchronous belt with trapezoidal tooth profile for traditional synchronous applications. Available in XL, L, H, XH and XXH cross sections.	Tension Section of V-Belt	The tension section of a v-belt is made of synthetic rubber specially formulated to stretch as the belt bends around the sheaves.
Synchronous Backlash	The necessary clearance between belt teeth and sprocket grooves for proper meshing in a synchronous belt drive system.	Tension-Finder®	Timken's quick, easy and accurate tool for tensioning v-belts. The Tension-Finder is designed for use with Timken belts. Do not use on belts with aramid, glass or carbon fiber cord.
Synchronous Belt	The term timing belt and synchronous belt can be used interchangeably to describe a belt that is capable of synchronizing two or more shafts. Synchronous belts rely on the accurate and smooth meshing of the teeth on the belt with the grooves of a sprocket. Referred to as timing, positive-drive or synchronous belts.	Tension-Finder Jr.	Timken tool to quickly, easily and accurately tension a new v-belt. It's half the size of the Tension-Finder for use on smaller drives with span lengths of 6 to 12 inches.
Synchronous Pitch Length	Synchronous belt pitch length is the total length (circumference) as measured along the pitch line. Synchronous belt pitch is the distance between two adjacent tooth centers. Determine the pitch length by multiplying the belt pitch by the number of teeth.	Tensioning	One of the most common causes of belt failure is improper tensioning. In order to ensure a long and efficient service life, belts must be properly installed and tensioned. Too little tension results in slippage, causing rapid v-belt and sheave wear. Too much tension results in excessive stress on the belts, bearings and shafts. Proper tensioning extends belt life, saves energy and reduces downtime.
		Thoro-Twist Belting	Thoro-Twist is a urethane belt designed for drives that have no take-up adjustment capability or for use as an emergency replacement. Thoro-Twist can be assembled by hand and rolled onto the drive like a bicycle chain. Thoro-Twist has the same cross section dimensions as regular belts and can be installed on existing sheaves. Available in 3L, A, B, and C cross sections in 30 meter rolls.

Timing Belt	The term timing belt and synchronous belt can be used interchangeably to describe a belt that is capable of synchronizing two or more shafts. Timing belts rely on the accurate and smooth meshing of the teeth on the belt with the grooves of a sprocket. Referred to as timing, positive-drive or synchronous belt.
Tolerance	A tolerance is defined as an allowable variation in the dimensions of a product. The tolerances are defined by various standards organizations. Timken belts meet or exceed ARPM, MPTA, ISO and DIN standards.
Torque	The twisting or turning effort around a shaft tending to cause rotation. Torque is determined by multiplying the applied force by the distance from the point where force is applied to the shaft center.
Tooth Facing	The facing of a Timken synchronous belt tooth is a specially woven and treated fabric that reduces the friction of the belt in the sprocket and resists abrasion and wear.
Ultra-Cord®	Timken tensile member that provides high strength and dimensional stability. Ultra-Cord delivers low tension decay and long belt life.
Variable Speed Cog-Belt®	Timken variable speed cog-belts are designed for use with industrial variable speed pulleys to gain a wide range of driven speeds.
Variable Speed Drive	Variable speed drives are designed to allow changes to driven shaft speed where the drive motor speed is fixed. Used in applications where drive speed is increased or decreased frequently to accommodate varying process conditions. The drive uses sheaves which have one or both sides movable in order to change the diameter at which the belt operates, and thus the rotational speed of the driven shaft. Also referred to as multi-speed, adjustable speed and variable pitch drives.
V-Belt	The function of a v-belt is to transmit power from one shaft to another through a driver to a driven pulley (sheaves). The belts must transfer this power efficiently and reliably. V-belts work on the principle of the wedge and rely on proper tension to create friction or grip on the sidewall of the sheave to transmit power.
V-Belt Drive	Common and economical system for transmitting power from a drive to a driven shaft. The drive uses v-belts and grooved sheaves or pulleys. V-belts work on the principle of the wedge and rely on tension to create friction on the sidewall of the sheave to transmit power. V-belt drive systems are easy to install, require no lubrication, and dampen shock load.

Vee-Rib Belt	Timken name for a flexible flat belt with multiple v-shaped ribs running the length of the belt. Vee-Rib belts operate efficiently with high load-carrying capacity at high speeds on small diameter pulleys providing smooth, vibration-free performance in a compact drive. Vee-Rib belts are available in J cross section. K, L, and M are also popular v-ribbed cross sections. Also referred to as v-ribbed, multi-rib, Micro-V® and Poly-V®.
Vulcanization	Belts are vulcanized or cured in a chemical process in which elastomers are heated to form cross-links between molecules to achieve improved durability, elasticity, resilience, tensile strength, viscosity, hardness, and other properties. The word vulcanization is derived from Vulcan, the Roman god of fire.
Wallboard	A popular merchandising and display system for v-belts.
Wrapped Molded V-Belt	Wrapped molded belts have a fabric cover and are molded into a V shape. The cover protects the core. Wrapped belts are the preferred drive solution for clutching or shock load applications.

Some products mentioned are trademarks or registered trademarks of their respective owners.

Bando® is a registered trademark of Bando Chemical Industries, Ltd. Optibelt® is a registered trademark of the OPTIBELT Corporation. PIX® is a registered trademark of Pix Transmissions Limited. Thermoid® is a registered trademark of HBD/Thermoid, Inc. TB Woods® is a registered trademark of TB Wood's Incorporated. Browning® is a registered trademark of Regal Beloit America, Inc. ContiTech® is a registered trademark of ContiTech AG. Gates®, PowerGrip®, HTD® and GT® are registered trademarks of Gates Corporation. Jason® is a registered trademark of Jason Industrial, Inc. Megadyne® is a registered trademark of Megadyne S.p.A. MBL® is a registered trademark of Mitsubishi Belting Ltd. Martin® MPC® are registered trademarks of Martin Sprocket & Gear, Inc. Product names are trademarks of their respective companies.

The following are registered trademarks of The Timken Company or its affiliates. Aramax®, Blue Label®, Chek Mate®, Cog-Band®, Cog-Belt®, Cotton Drive®, Drive Engineer®, Durapower®, Gold-Ribbon®, Panther®, Power-Wedge®, RPP®, Super Ag-Drive®, Super Blue Ribbon®, Super II®, Synchro-Cog®, Super Vee-Band®, Tension-Finder®, The Right Belt for the Job®, Timken®, Ultimax®, Ultra-Cord®, and Wedge-Band®.

Notes

Timken Belts

2601 West Battlefield Road
Springfield, MO 65807

USA Customer Service: 877-484-6536
Email: customerservicebelts@timken.com

© 2021 The Timken Company

TIMKEN BELTS

Timken Belts is part of The Timken Company's growing portfolio of engineered bearings and power transmission products. A manufacturer of premium performance power transmission belts, Timken Belts' associates and products help keep industry in motion and the world more productive.

Performance Driven. **Performance Proven.**