

TIMKEN PREMIUM WHEEL END SEALS

TIMKEN

Timken. A long-standing brand trusted by fleets because we understand commercial vehicle applications and the value of uptime. Your confidence is our commitment, providing products with reliable operation and outstanding performance designed to **MAXIMIZE FLEET UPTIME, OPERATIONS AND YOUR BOTTOM LINE.**

A Simplified Installation: Installable with any flat tool including your hand, the ribbed rubber OD with piloted installation guide promotes accurate and square installation to reduce cocked seals.

B Extended Seal Life: Advanced material compositions (HNBR: Hydrogenerated Nitrile Butadiene Rubber) on all sealing lip and outer diameter surfaces promote longer seal life across a broad temperature range (-40°F to 310°F [-40°C to 154°C]), including hot starts and braking.

C Advanced Protection: Three additional contaminant exclusion barriers help prevent dirt and other debris from causing premature seal failure.

D Impressive Sealing: Wide shoulder coverage provides protection on worn or damaged axle shoulders.

Stronger Value: Designed to meet or exceed the features of major industry competitors.

Visit www.timken.com/cwarranty for CV Wheel End Components Warranty information.

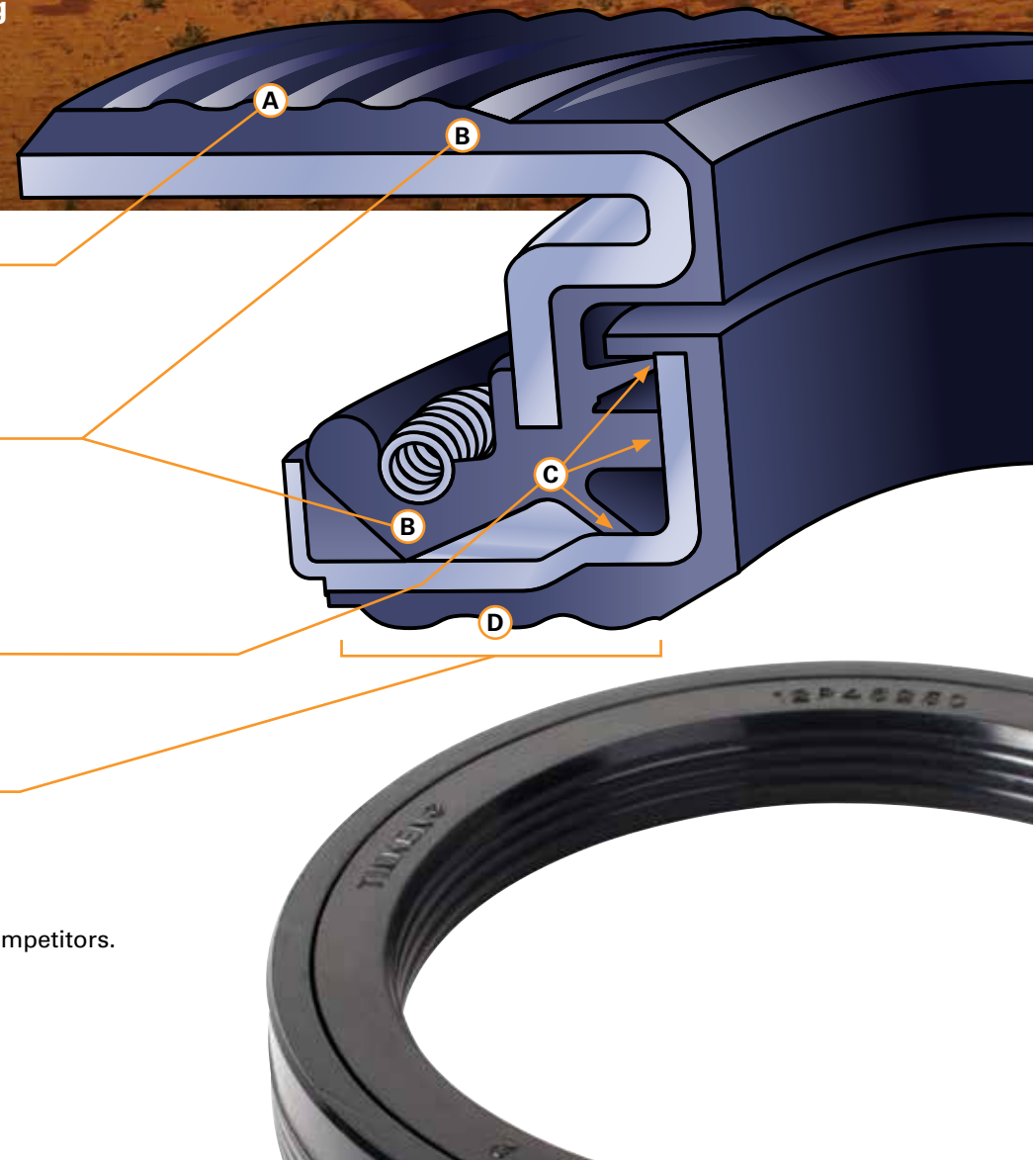

INTERCHANGE: TIMKEN PREMIUM WHEEL END SEALS

TIMKEN			STEMCO	SKF	NATIONAL	MERITOR	TRISEAL
Premium Series	Commercial Grade Tool P/N	Application	Discover	Scotseal PlusXL	38 Series	Premium	Premium Series
Front Axle Seals							
10P28750*	Hand Installed	6,000#, 7500#, Front Axle, Navistar	383-0166	28748	370150A		65550
10P35000	Hand Installed	12,000# Front Axle, Eaton, Ford, Freightliner, Kenworth, Meritor, Navistar, Peterbilt, Volvo GM, Western Star	383-0236	35058	380001A	MER0236	65563
10P43750*	Hand Installed	16,000# Front Axle, Ford, Kenworth, Mack, Meritor, Navistar, Peterbilt, Volvo GM, White, Western Star	383-0264	43764	380048A		65592
Drive Axle Seals							
11P38750	Hand Installed	34,000# Drive Axle, Eaton, Ford, Navistar, White	393-0212	38776	380023A	MER0212	65552
11P47670	Hand Installed	38,000#, 46,000# Tandem Axle, Eaton, Ford, Freightliner, Kenworth, Meritor, Navistar, Peterbilt, Volvo GM, Western Star	393-0273	47691 / 47692	380003A	MER0273	65556
11P48750	Hand Installed	Meritor Drive-Transit	393-0134	48690	370195A		11P48750
Trailer Axle Seals							
12P31250	Hand Installed	Hayes and 10,000# - 15,000# Dexter	372-7049 / 382-8010 / 382-8062	31281	370014A		12P31250
12P40000*	Hand Installed	19,000# Trailer Axle, Dana, Eaton, Standard Forge	373-0213	40129	380036A		65561
12P42500	Hand Installed	Propar Trailer Axle, Dana, Eaton P-22, Fruehauf, Meritor TP	373-0223	42627	380065A	MER0223	65562
12P43750*	Hand Installed	20,000# Trailer Axle, Meritor, Shuler		43754			65598
12P46250	Hand Installed	22,500# Trailer Axle, Dana, Eaton, Meritor TN, Standard Forge	373-0243	46300	380025A	MER0243	65560

*New Item, Check for Availability

Bold = Priority Stocking Part Numbers

NOMENCLATURE

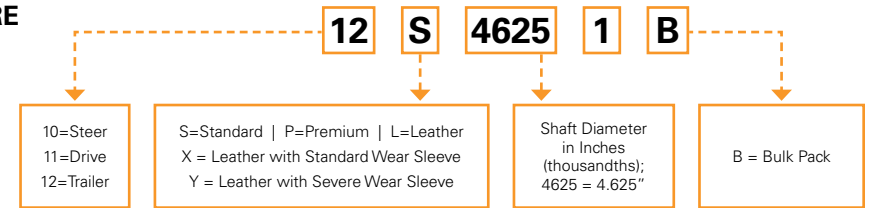

TIMKEN

The Timken team applies their know-how to improve the reliability and performance of machinery in diverse markets worldwide. The company designs, makes and markets bearings, gear drives, automated lubrication systems, belts, brakes, clutches, chain, couplings, linear motion products and related industrial motion rebuild and repair services.

Stronger. By Design.



Visit [timken.com/techseriespro](https://www.timken.com/techseriespro) to enroll in free technical training.
www.timken.com/aftermarket