

TIMKEN



TIMKEN® SOLID-BLOCK MOUNTED SPHERICAL ROLLER BEARINGS



ABOUT THE TIMKEN COMPANY

The Timken Company designs a growing portfolio of engineered bearings and industrial motion products. With more than a century of knowledge and innovation, we continuously improve the reliability and efficiency of global machinery and equipment to move the world forward.

With one common global quality system across all manufacturing plants, we deliver consistent product performance and reliability anywhere in the world.

As a Timken customer, you are connected to a team of application, sales and on-site service engineers who help solve unique equipment challenges resulting in extended uptime, productivity and efficiency.

To view more Timken catalogs, go to www.timken.com/catalogs for interactive versions, or to download our catalog app to your smartphone or mobile device.



TIMKEN® SOLID-BLOCK MOUNTED SPHERICAL ROLLER BEARING CATALOG INDEX

INTRODUCTION	2
HOW TO USE THIS CATALOG.....	6
SHELF LIFE/ STORAGE.....	7
WARNINGS.....	8

ENGINEERING

Nomenclature.....	10
Locking Styles	15
Seal and Cover Options	16
Bearing Loads	34
Normal Speed Ratings for Seals	57
Internal Radial Clearances	63
Shafting.....	65
Lubrication	67
Misalignment	67
Installation Guides	68

SOLID-BLOCK MOUNTED SPHERICAL ROLLER BEARINGS

V-Lock® Series (taper lock).....	89
CL Series (concentric [set screw] lock)	137
EC Series (eccentric lock).....	179
TA/DV TAA/DAA Series (tapered adapter lock)	209
Take-Up Frames.....	253

Index	260
-------------	-----

INTRODUCTION

When your equipment faces harsh environments, you need mounted roller bearings that are rugged enough to withstand tough conditions and deliver exceptional performance.

You gain both with Timken® solid-block mounted spherical roller bearings.

Designed specifically to perform under extreme conditions, Timken solid-block mounted bearings are able to accept a total of 1.5 degrees misalignment and withstand the impact of falling debris. Additional misalignment can be accommodated for applications with lighter loads, contact your Timken engineer for details. Made of cast-steel housings and Timken double-row spherical roller bearings, their unique sealing design offers protection from contaminants.

Increased performance and durability help decrease the overall cost of ownership.

CUSTOMIZABLE DESIGN FEATURES TO FIT YOUR EQUIPMENT

With a full line of precision-made shaft-locking styles, seals and housings, it's easy to find the right mounted bearing to fit your application. Timken solid-block mounted spherical roller bearings interchange with a wide range of mounted roller bearings. Choose from many primary and secondary sealing mechanisms, and you decide how it's built without paying custom charges.

HOUSING STYLES

- Two-bolt pillow blocks
- Four-bolt pillow blocks
- Flange blocks
- Piloted flanges
- Take-up blocks
- Cartridge units
- Hanger blocks

LOCKING STYLES

- Eccentric lock
- Concentric lock (set screw) – single or double collar
- Tapered adapter lock – single or double nut
- V-Lock® tapered lock – single or double nut

SEALS

- Labyrinth seals – DuPont™ Teflon®:
 - High-speed applications
 - Superior in dirty and wet conditions
 - Able to operate at high temperatures
 - Resistant to most chemicals
 - Abrasion-resistant
- Triple-lip seals – nitrile:
 - Self-purging
 - Excellent in dirty and wet applications
 - Chemical- and corrosion-resistant
- Triple-lip seals – urethane:
 - All the benefits of nitrile, plus resistance to abrasion

SECONDARY SEALS

- Closed-end covers
- Open-end covers with:
 - Triple-lip seal
 - DuPont Teflon
 - V-ring seal
- Piloted-flange cartridge backing plates with:
 - Triple-lip seal
- Flange block backing plates with V-ring seal or Teflon seal

HOUSING COATINGS

- Powder coating – standard
- Nickel plating – optional
- Fluoropolymer coating – optional



Fig. 1. Two-bolt pillow block.



Fig. 2. Four-bolt pillow block.

OUTLASTING THE COMPETITION

Timken solid-block mounted bearings last a long time, yet you don't pay extra for reliability. Experience an increase in performance and durability and a decrease in your overall cost of ownership when you use a Timken solid-block mounted bearing.

STANDS UP TO HARSH CONDITIONS

Protects Bearing. Harsh operating environments and lubrication issues often lead to mounted bearing damage. Timken solid-block mounted bearings multiply protection with primary and secondary seal options, as well as steel covers in sizes to fit these units. The space between the primary and secondary seals offers a fillable grease cavity for more protection.

Handles Misalignment. Without a properly aligned shaft, the life expectancy of most mounted bearings decreases. However, Timken solid-block mounted spherical roller bearings accept a total of 1.5 degrees of misalignment, thanks to their unique design and Timken spherical roller bearings. Additional misalignment can be accommodated for applications with lighter loads, contact your Timken engineer for details.



Fig. 3. Flange block.



Fig. 4. Take-up block.



Fig. 5. Piloted-flange cartridge.



Fig. 6. Cartridge block.

INDUSTRIES AND APPLICATIONS

- Metal mills
- Aggregate and cement
- Mining
- Power generation
- Sawmills and other forest process industries
- Pulp and paper
- Material conveying
- Commercial and industrial building equipment
- Sugar mills
- Agriculture
- Waste management and water treatment
- Off-highway and construction vehicles
- HVAC, fans and blowers
- Cranes, lifts and hoists

DEPENDABLE SERVICE

Every Timken solid-block mounted spherical roller bearing is backed by the service of our industry-leading experts who are ready to assist you with product design, application knowledge and field engineering support – anything you need to help improve uptime and maximize equipment performance.

SOLID-BLOCK MOUNTED BEARING BENEFITS

Depending on how you configure your bearing for a specific application, there's a wide range of product benefits.

- Multiple available sizes accommodate shaft diameters from 35 mm to 380 mm (1 7/16 in. to 15 in.).
- Efficient built-to-order manufacturing. Quick delivery of customized configurations for specific applications.
- Quicker installation. Machined feet, tapped puller holes, black oxide inner rings and multiple shaft-locking choices make it simpler to install this heavy-duty unit.
- Improved performance in high-contaminant environments. Wide selection of primary and secondary seals, as well as auxiliary covers.
- Bidirectional shaft expansion. Double-nut housing feature allows expansion in both directions.
- Increased uptime. Robust steel housing, a wide variety of seal choices and a high-performance Timken spherical roller bearing result in increased unit uptime.
- Increased shaft holding power and reduced shaft damage. Eccentric lock series is designed to stay tight in reversing applications on precision-ground shafts.
- Fewer misalignment issues. Bearings accept up to 1.5 degrees of misalignment.
- Protection against over-lubrication. Pressure relief valves come standard when unit is ordered with non-purgeable seals.
- Dimensionally interchanges with a wide range of other mounted roller bearing units.
- One-time shaft alignment on all mounted bearing styles. Machined feet ends allow for precise installation and blocking for faster future unit replacement.
- Easier removal with standard withdrawal holes on all piloted-flange units.
- Faster and easier changeover thanks to a comprehensive product offering that interchanges with virtually all solid-block roller bearing units.

SOLID-BLOCK MOUNTED BEARING DESIGN

Flexibility through interchangeable components.

Double-row spherical roller bearing accepts misalignment

Black oxide inner ring reduces shaft fretting corrosion

Six primary seals in any combination:

- T seal standard labyrinth (DuPont Teflon)
- M seal standard lip (nitrile rubber)
- N seal optional (Viton™)
- O seal optional (urethane)
- B seal optional (nitrile rubber)
- C seal optional (Viton)

Housing fit: J7, size-for-size to light interference

Standard relief valve

Optional bolt-on open and closed steel or urethane secondary seals

Lubricated with premium industrial grease

Shaft-locking styles:

- Set screw
- Eccentric
- Tapered adapter
- V-Lock double tapered lock

Easily converted to fixed or expansion in the field

Housing can be supplied with powder coating (standard), nickel plating or fluoropolymer coatings

Housing manufactured from 75000 psi tensile cast steel that retains the bearing-to-housing fit for those rough applications

Machined feet aid in rapid installation and alignment

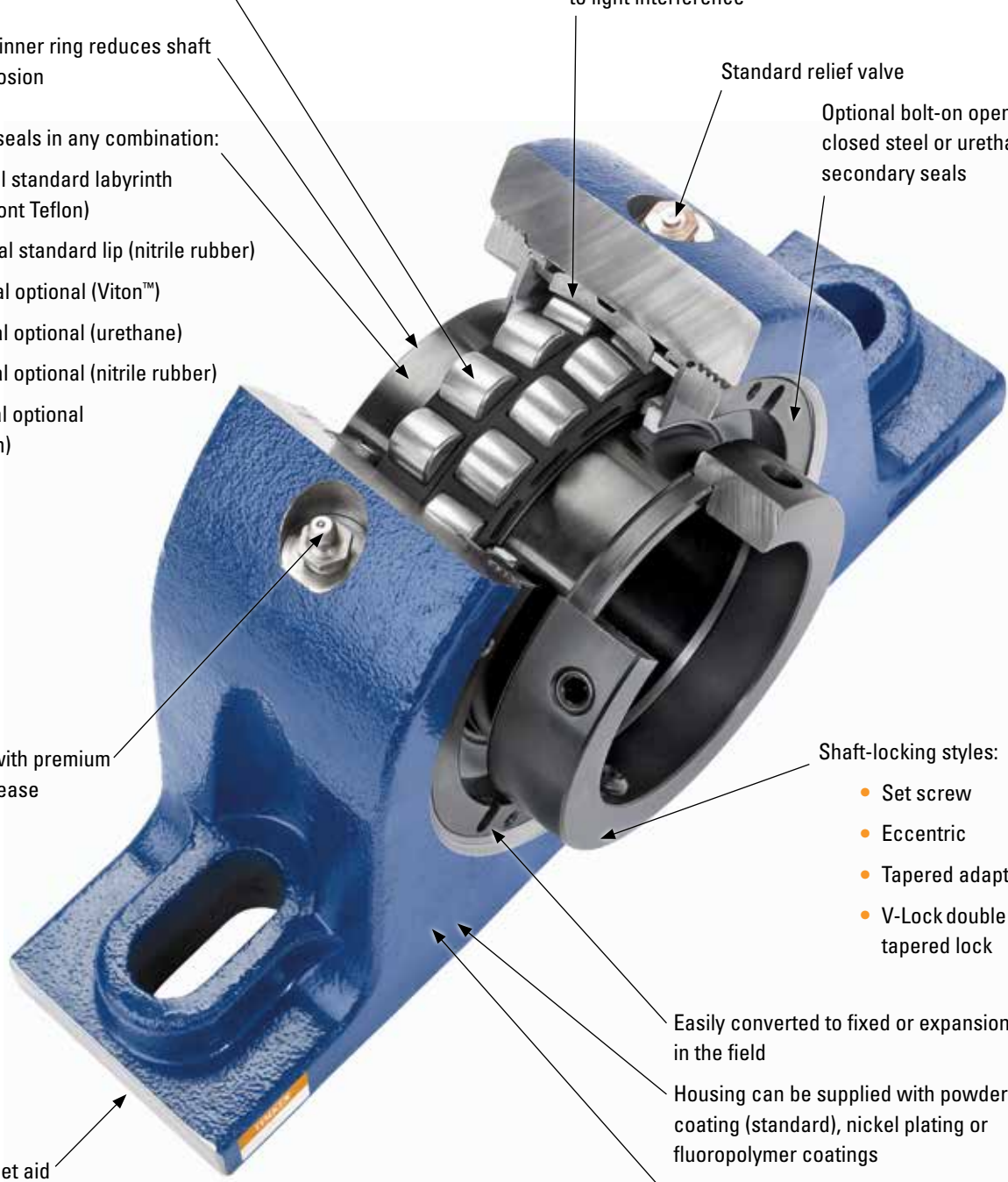

Fig. 7. High performance plus superior ruggedness.

HOW TO USE THIS CATALOG

We designed this catalog to help you find the Timken solid-block mounted spherical roller bearings best suited to your specifications.

Timken offers an extensive range of bearings and accessories in both imperial and metric sizes. For your convenience, size ranges are indicated in millimeters and inches. Contact your Timken engineer to learn more about our complete line for the special needs of your application.

This publication contains dimensions, tolerances and load ratings, as well as engineering sections describing fitting practices for shafts and housings, internal clearances, materials and other bearing features. It provides valuable assistance in the initial consideration of the type and characteristics of the bearings that may best suit your particular needs.

ISO and ANSI/ABMA, as used in this publication, refer to the International Organization for Standardization and the American National Standards Institute/American Bearing Manufacturers Association.



SHELF LIFE AND STORAGE OF GREASE-LUBRICATED BEARINGS AND COMPONENTS

To help you get the most value from our products, Timken provides guidelines for the shelf life of grease-lubricated ball and roller bearings, components and assemblies. Shelf life information is based on Timken and industry test data and experience.

SHELF LIFE

Shelf life should be distinguished from lubricated bearing/component design life as follows:

Shelf life of the grease-lubricated bearing/component represents the period of time prior to use or installation.

The shelf life is a portion of the anticipated aggregate design life. It is impossible to accurately predict design life due to variations in lubricant bleed rates, oil migration, operating conditions, installation conditions, temperature, humidity and extended storage.

TIMKEN IS NOT RESPONSIBLE FOR THE SHELF LIFE OF ANY BEARING/COMPONENT LUBRICATED BY ANOTHER PARTY.

European REACH compliance

Timken lubricants, greases and similar products sold in standalone containers or delivery systems are subject to the European REACH (Registration, Evaluation, Authorization and Restriction of CHemicals) directive. For import into the European Union, Timken can sell and provide only those lubricants and greases that are registered with ECHA (European CHemical Agency). For further information, please contact your Timken engineer.

STORAGE

Timken suggests the following storage guidelines for our finished products (bearings, components and assemblies, referred to as "products"):

- Unless directed otherwise by Timken, products should be kept in their original packaging until they are ready to be placed into service.
- Do not remove or alter any labels or stencil markings on the packaging.
- Products should be stored in such a way that the packaging is not pierced, crushed or otherwise damaged.
- After a product is removed from its packaging, it should be placed into service as soon as possible.
- When removing a product that is not individually packaged from a bulk pack container, the container should be resealed immediately after the product is removed.
- The storage area temperature should be maintained between 0° C and 40° C; temperature fluctuations should be minimized.
- The relative humidity should be maintained below 60 percent and the surfaces should be dry.
- The storage area should be kept free from airborne contaminants such as, but not limited to, dust, dirt, harmful vapors, etc.
- The storage area should be isolated from undue vibration.
- Extreme conditions of any kind should be avoided.

Due to the fact that Timken is not familiar with your particular storage conditions, we strongly suggest following these guidelines. However, you may be required by circumstances or applicable government requirements to adhere to stricter storage requirements.

Most bearing components typically ship protected with a corrosion-preventive compound that is not a lubricant. These components may be used in oil-lubricated applications without removal of the corrosion-preventive compound. When using some specialized grease lubrications, we advise you to remove the corrosion-preventive compound before packing the bearing components with suitable grease.

Be careful in selecting lubrication, however, since different lubricants are often incompatible.

When you receive a bearing shipment, do not remove products from their packaging until they are ready for mounting so they do not become corroded or contaminated.

Store bearings and bearing housings in an appropriate atmosphere so they remain protected for the intended period.

WARNINGS



WARNING

Failure to observe the following warnings could create a risk of death or serious injury.

Proper maintenance and handling practices are critical. Always follow installation instructions and maintain proper lubrication.

Overheated bearings can ignite explosive atmospheres. Special care must be taken to properly select, install, maintain and lubricate mounted bearings that are used in or near atmospheres that may contain explosive levels of combustible gases or accumulations of dust such as grain, coal, or other combustible materials. Consult your equipment designer or supplier for installation and maintenance instructions.

If hammer and bar are used for installation or removal of a part, use a mild steel bar (e.g., 1010 or 1020 grade). Mild steel bars are less likely to cause release of high speed fragments from the hammer or bar or the part being installed or removed.



CAUTION

Failure to follow these cautions may result in property damage.

Do not use damaged mounted bearings.

Warnings for this product line are in this catalog and posted on www.timken.com/en-us/products/warnings

NOTE

Do not use excessive force when mounting or dismounting the unit.

Follow all tolerance, fit, and torque recommendations.

Always follow the Original Equipment Manufacturer's installation and maintenance guidelines.

Ensure proper alignment.

Never weld mounted bearings.

Do not heat components with an open flame.

Do not operate at bearing temperatures above 250° F (121° C).

When converting a solid-block mounted bearing from fixed to expansion, it is imperative that the unit that is going to be converted is correctly oriented. Since the insert in a steel mounted flange bearing is held against either a shoulder or snap ring opposite the housing retaining nut, a flange bearing that has

been converted to expansion can only float in the direction of the retaining nut. Based on this, the retaining nut must be on the side of the housing opposite the fixed bearing.

When converting a solid-block mounted bearing from expansion to fixed on a mounted bearing, the locking-collar set screws must be released to allow the insert to move both in the housing and on the shaft.

DISCLAIMER

This catalog is provided solely to give you analysis tools and data to assist you in your product selection. Product performance is affected by many factors beyond the control of Timken. Therefore, the suitability and feasibility of all product selection must be validated by you.

Timken products are sold subject to our terms and conditions of sale, which include its limited warranty and remedy, which terms may be found at <https://www.timken.com/legal-notice/termsandconditionsofsale/>

Please consult with your Timken engineer for more information and assistance.

Every reasonable effort has been made to ensure the accuracy of the information in this writing, but no liability is accepted for errors, omissions or for any other reason.

COMPLIANCE

To view the complete engineering catalog, please visit www.timken.com. To order the catalog, please contact your Timken sales engineer and request a copy of the Timken Engineering Manual (order number 10424).

The Timken Company products shown in this catalog may be directly, or indirectly subject to a number of regulatory standards and directives originating from authorities in the USA, European Union, and around the world, including: REACH (EC 1907/2006, RoHS (2011/65/EU), ATEX (94/9/EC), 'CE' MARKING (93/68/EEC), CONFLICT MINERALS (Section 1502 of the Dodd-Frank Wall Street Reform and Consumer Protection Act).

For any questions or concerns regarding whether Timken products comply with these, or other regulatory standards or directives, please contact your Timken engineer or customer services representative.

Updates are made periodically to this catalog. Visit www.timken.com for the most recent version of the Timken Solid-Block Mounted Spherical Roller Bearing Catalog.



ENGINEERING

The following topics are covered within this section:

Nomenclature.....	10
Locking Styles.....	15
Seal and Cover Options.....	16
Bearing Loads.....	34
Normal Speed Ratings for Seals.....	57
Internal Radial Clearances.....	63
Shafting.....	65
Lubrication.....	67
Misalignment.....	67
Installation Guides.....	68



To view more Timken catalogs, go to www.timken.com/catalogs for interactive versions, or to download the Timken catalog app for your smartphone or mobile device scan the QR code or go to timkencatalogs.com.

NOMENCLATURE

ORDERING SOLID-BLOCK MOUNTED BEARINGS

Every solid-block mounted bearing is made of cast steel for greater strength (compared to cast iron). All bearings feature a double-row, spherical roller bearing design for a high load-carrying capacity, misalignment tolerance and reduced friction.

Starting with these standard design advantages, you can choose from a wide range of sizes, locking styles, seal options and housing styles suited precisely for your application.

There are many ways to determine the correct solid-block mounted bearing part number for ordering purposes:

- Once you determine the best locking style, housing and seal options for your application, you can easily find the correct part number in the tables included in the following sections.
- If you are ordering a replacement for an existing mounted bearing, locate the part number for that mounted bearing on the housing tag.
- If none of the above apply, or if you have additional questions or concerns about ordering the correct mounted bearing, contact your Timken engineer.



SOLID-BLOCK MOUNTED SPHERICAL ROLLER BEARING

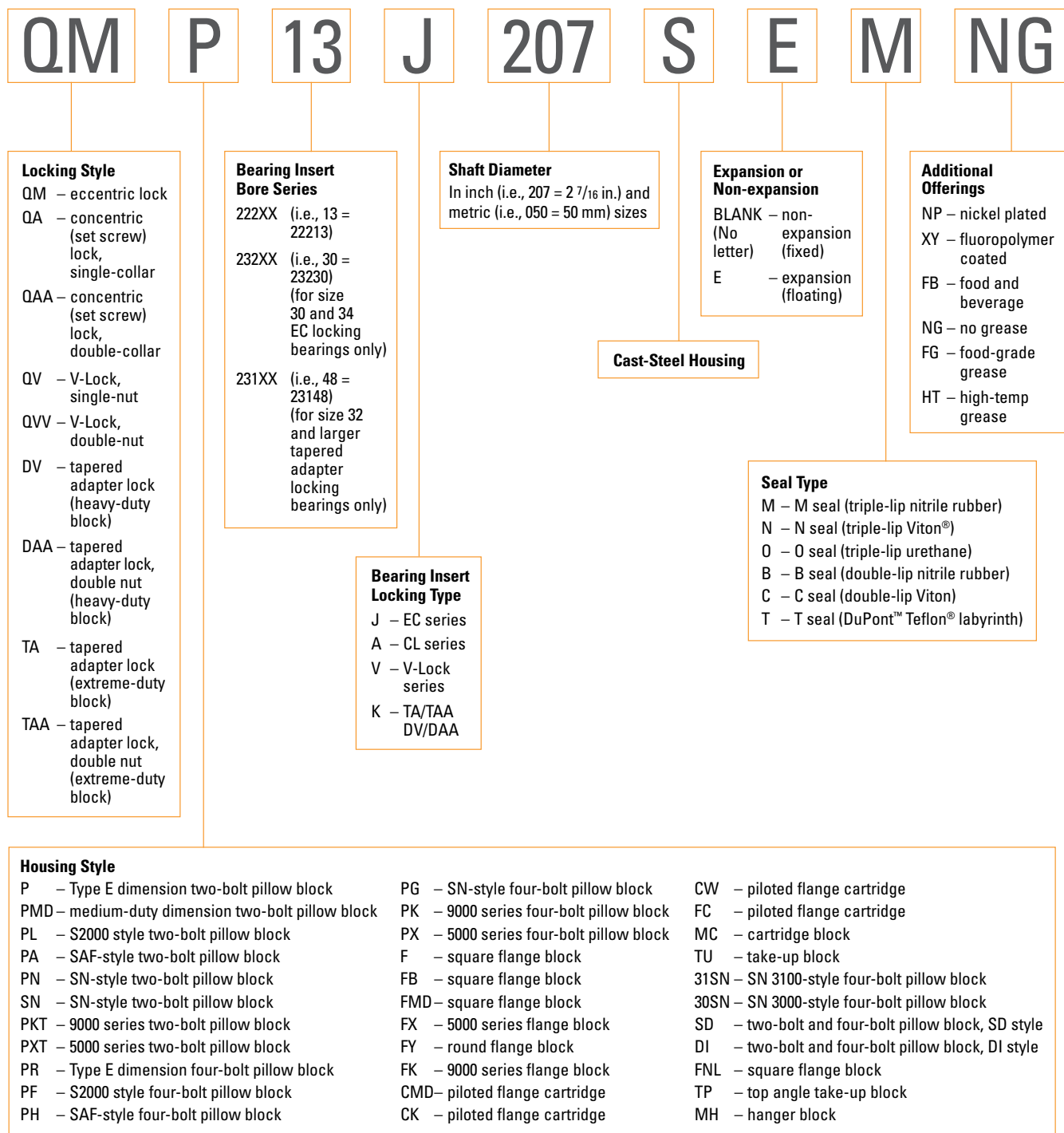

STEEL COVER

OPEN-END STEEL COVER

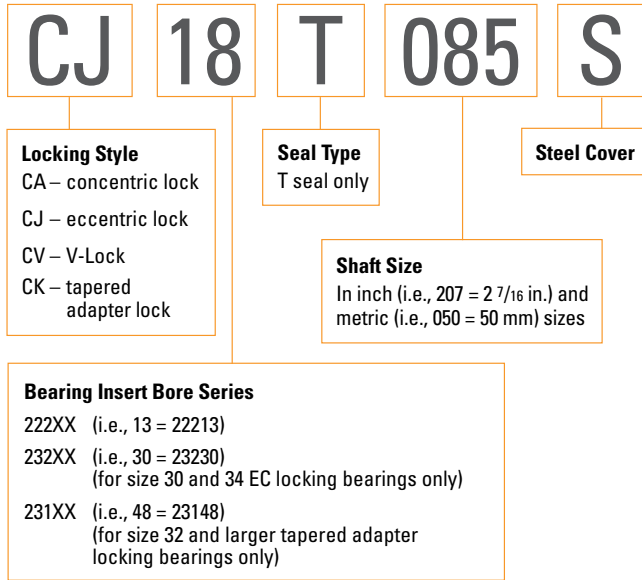

STEEL COVER

CLOSED-END STEEL COVER

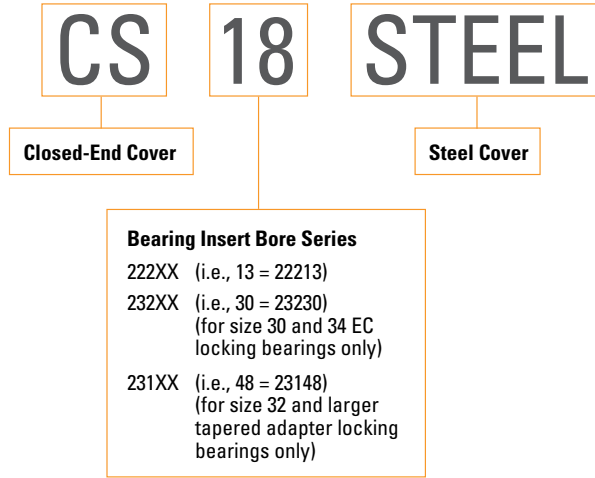

URETHANE COVER

OPEN-END COVER WITH DR SEAL

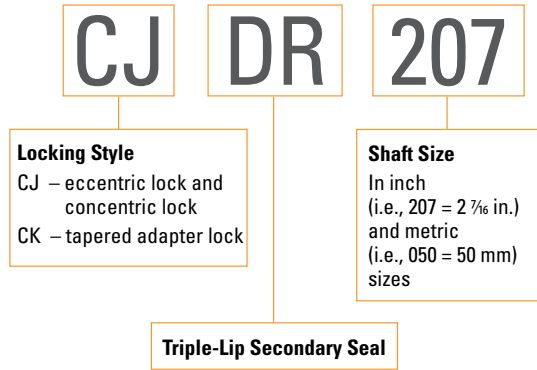

V-LOCK OPEN-END COVER WITH DR SEAL

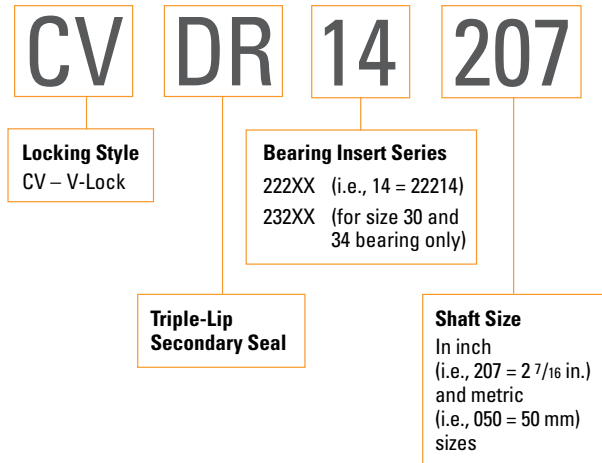

OPEN-END COVER WITH VR SEAL

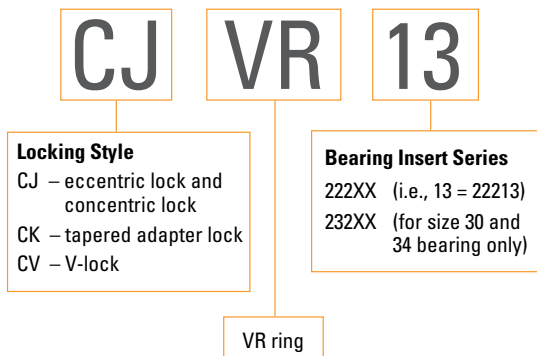

CLOSED-END COVER

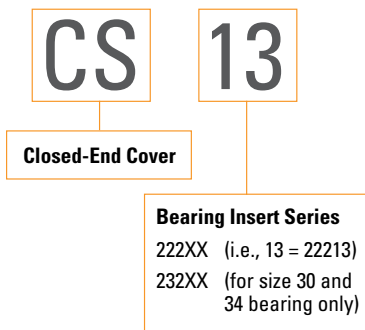

BACKING PLATE CL AND EC SERIES BEARINGS

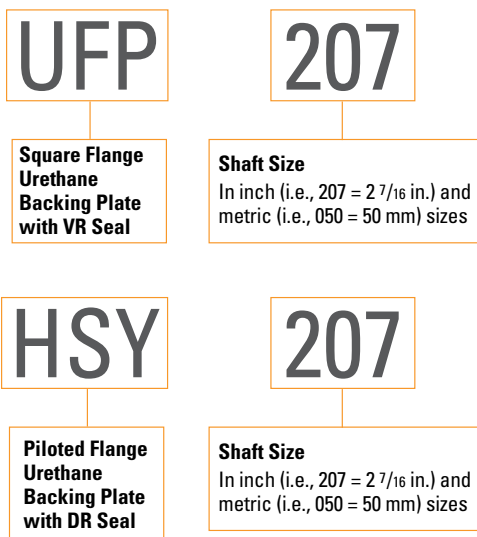

HIGH-PERFORMANCE STEEL BACKING PLATE CL and EC series bearings

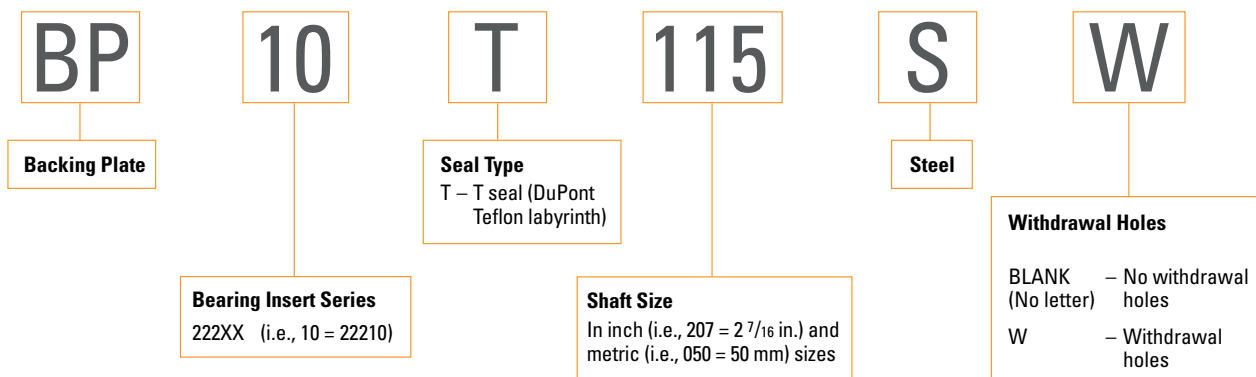

COMPARISON CHART

TABLE 1. COMPARISON CHART

	Housing Type	Primary Seals						Secondary Seals and Covers					
		M	N	O	B	C	T	Open-End Cover			Closed-End Cover	HSY Flange Cartridge Backing Plate	UFP Backing Plate
								DR	VR	T		DR	
V-Lock (Timken Exclusive Double Taper Lock)	Pillow Block	•	•	•	•	•	•	•	•	•	•		
	Flange Block	•	•	•	•	•	•	•	•	•	•		
	Piloted Flange Cartridge	•	•	•	•	•	•	•	•	•	•		
	Take-up Block	•	•	•	•	•	•	•	•	•	•		
	Cartridge Block	•	•	•	•	•	•	•	•	•	•		
CL Series (Set Screw Lock)	Pillow Block	•	•	•	•	•	•	•	•	•	•		
	Flange Block	•	•	•	•	•	•	•	•	•	•		•
	Piloted Flange Cartridge	•	•	•	•	•	•	•	•	•	•	•	
	Take-up Block	•	•	•	•	•	•	•	•	•	•		
	Cartridge Block	•	•	•	•	•	•	•	•	•	•		
	Hanger Block	•	•	•	•	•	•	•	•	•	•		
EC Series (Eccentric Lock)	Pillow Block	•	•	•	•	•	•	•	•	•	•		
	Flange Block	•	•	•	•	•	•	•	•	•	•		•
	Piloted Flange Cartridge	•	•	•	•	•	•	•	•	•	•	•	
	Take-up Block	•	•	•	•	•	•	•	•	•	•		
	Cartridge Block	•	•	•	•	•	•	•	•	•	•		
	Hanger Block	•	•	•	•	•	•	•	•	•	•		
TA/TAA Series (Tapered Adapter Lock)	Pillow Block	•	•	•	•	•	•	•	•	•	•		
	Flange Block	•	•	•	•	•	•	•	•	•	•		
	Piloted Flange Cartridge	•	•	•	•	•	•	•	•	•	•		
	Cartridge Block	•	•	•	•	•	•	•	•	•	•		
DV/DAA Series (Tapered Adapter Lock)	Pillow Block	•	•	•	•	•	•	•	•	•	•		
	Flange Block	•	•	•	•	•	•	•	•	•	•		
	Piloted Flange Cartridge	•	•	•	•	•	•	•	•	•	•		

LOCKING STYLES

V-LOCK (DOUBLE-TAPERED LOCK) U.S. PAT. NO. 7344313

The V-Lock locking mechanism is excellent in high-speed applications and designed to maximize shaft-holding power and minimize the time needed for installation and removal as compared to conventional locking mechanisms. With no need for feeler gages during installation, the V-Lock locking mechanism offers superior holding power and is designed to eliminate overtightening. Mechanical withdrawal is a feature of double-nut units.

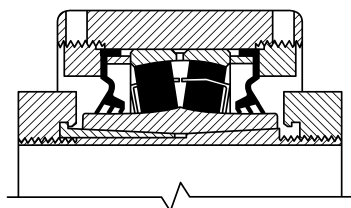

Fig. 8. V-Lock double tapered lock.

CONCENTRIC LOCK (SET SCREW) – CL SERIES

Two set screws positioned at 60 degrees provide aggressive holding power. When configured with a double-collared insert, the bearing provides double the holding power compared to our standard single-collared insert.

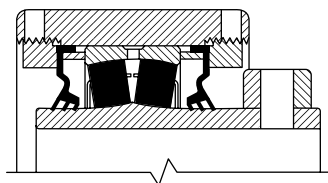

Fig. 9. Single set screw lock.

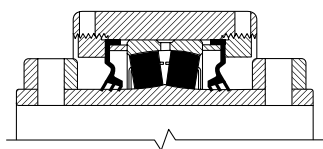

Fig. 10. Double set screw lock.

ECCENTRIC LOCK – EC SERIES

A reduced eccentric offset results in more mechanical advantage. This series provides a secure lock that should not release from a properly prepared shaft even in reversing applications.

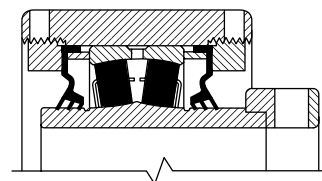

Fig. 11. Eccentric lock.

TAPERED ADAPTER LOCK – TA/TAA DV/DAA SERIES

Excellent in high-load applications, this design uses a longer 2300-series adapter for increased shaft contact. This design offers the best shaft concentricity and highest capacity all while having the ability to accommodate undersized shafting.

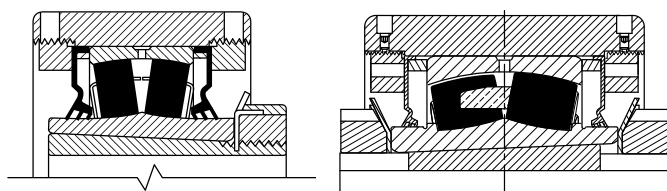

Fig. 12. Tapered adapter lock.

A simple design that in turn simplifies installation and removal of mounted bearings. The standard tapered adapter sleeve has been extended to accommodate a second nut on the back end. This nut is factory set for nominal shaft sizes and can be adjusted in the field to accommodate actual (under/over) shaft size if necessary.

HOUSING COATINGS

POWDER COATING – STANDARD

All of our steel housings come powder coated from the factory. Powder coating gives a hard finish that is tough and durable.

NICKEL PLATING – OPTIONAL

By nickel plating any of our housings, we are able to offer superior resistance to wear and corrosion.

FLUOROPOLYMER COATING – OPTIONAL

We have the ability to coat your housing with either industrial or food grade fluoropolymer for your washdown and/or food contact applications.

SEAL AND COVER OPTIONS

PRIMARY SEALS

Primary seals are installed between the inner ring of the bearing and the housing. They are held securely in place by the external housing nut. Primary seals can be contacting or non-contacting, purging or non-purging and are available in several material compounds for a variety of applications.

TRIPLE-LIP SEALS – CONTACTING, SELF-PURGING, LOW TO MODERATE SPEEDS⁽¹⁾

Timken offers three kinds of medium-contact triple-lip seals. Choose from seals made of nitrile synthetic rubber (acrylonitrile butadiene), Viton™ fluoroelastomer or urethane.

- **M Seal** – This seal, made of nitrile rubber, offers superior sealing in moist and dirty applications. It is chemical- and corrosion-resistant and provides excellent lubrication retention. It also allows excess grease to purge from the bearing cavity.
- **N Seal** – Made of Viton, this seal provides excellent chemical resistance and can operate at higher temperatures than nitrile rubber.
- **O Seal** – This seal, made of high-strength urethane for superior abrasion resistance.

LABYRINTH SEALS – NON-CONTACTING, NON-PURGING, ALL SPEEDS⁽²⁾

Instead of trying to form a seal with a single strong barrier, a labyrinth seal uses a winding passageway to accomplish the same reduction in flow. Not only is seal friction reduced, but so is seal wear.

- **T Seal** – This seal consists of a DuPont™ Teflon® ring pressed onto the inner ring of the bearing that floats between two pieces of formed steel to accommodate misalignment. When using this seal, the housing comes with a vent fitting. Developed for higher-speed applications involving dirty conditions or moisture-affected areas, it is able to operate at higher temperatures and is impervious to most chemicals.

DOUBLE-LIP SEALS – CONTACTING, NON-PURGING, LOW SPEEDS⁽¹⁾⁽²⁾

These seals incorporate a double-lip seal, a garter spring for maximum contact, and a heavy-duty steel shield that protects the seal from large pieces of debris that could damage the seal itself.

- **B Seal** – Made of nitrile rubber, this seal offers superior protection in applications with oil lubrication and is designed for extreme moisture, fine dust or extremely dirty applications. When using this seal, the housing comes with a vent fitting.
- **C Seal** – Made of Viton, this seal provides excellent chemical and abrasion resistance and can operate at higher temperatures than nitrile rubber. When using this seal, the housing comes with a vent fitting.

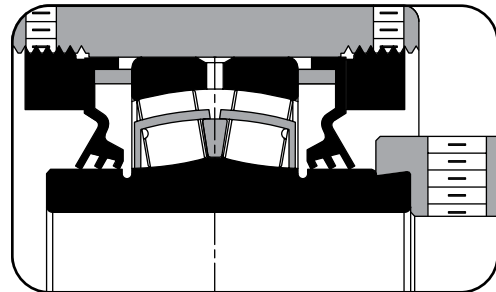

Fig. 13. Triple-lip seals.

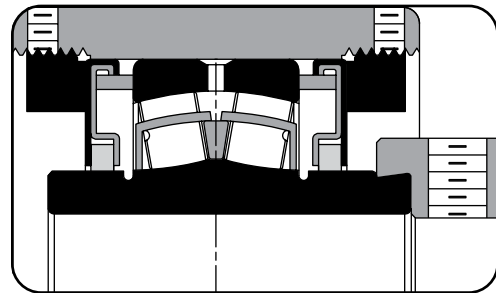

Fig. 14. T seal.

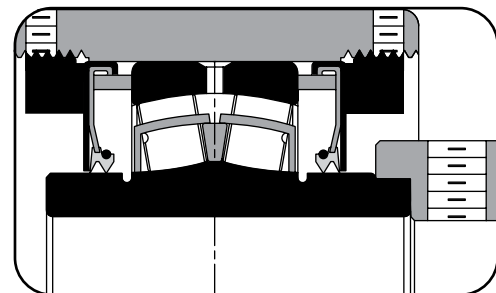

Fig. 15. Double-lip seals.

⁽¹⁾Temperature limit -40° C to 121° C (-40° F to 250° F) continuous, 149° C (300° F) intermittent. Constant seal-lip pressure on the inner ring results in higher operating temperatures of the complete unit. (See pages 57 – 59).

⁽²⁾Relief valve is standard.

SECONDARY SEALS

In many circumstances, bearings become damaged in housings due to premature primary seal wear. This is usually the result of harsh operating environments or lubrication issues. Timken offers secondary sealing options that provide an additional barrier to protect the primary seal. These economical secondary seals and covers are easily outfitted on virtually all solid-block mounted bearings.

STEEL COVERS

Labyrinth Seals – Non-Contacting, Non-Purging, All Speeds

A labyrinth seal uses a winding passageway to accomplish a reduction in flow instead of trying to form a seal with a single strong barrier. Seal friction and wear is reduced.

- T Seal** – This seal, which is used in the open-end steel covers, consists of a DuPont Teflon ring pressed onto the shaft that floats between two pieces of formed steel to accommodate misalignment. Developed for higher-speed applications involving dirty conditions or moisture-affected areas, it is able to operate at higher temperatures and is impervious to most chemicals, while avoiding shaft damage.

URETHANE COVERS

DR Triple-Lip Secondary Seal – Low Speeds

The DR seal is the standard triple-lip seal adapted for use on the open-end covers and piloted flange cartridge backing plates (HSY). This seal can move within the cover or backing plate opening to accommodate misalignment while maintaining full contact to the shaft for positive sealing.

VR Viton Ring Secondary Seal – High Speeds

The VR seal, made of nitrile rubber, rides on the shaft and seals against the open-end covers and flange block backing plates (UFP).

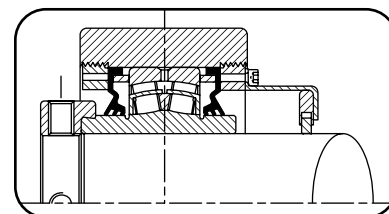

Fig. 16. Open-end steel cover with T seal.

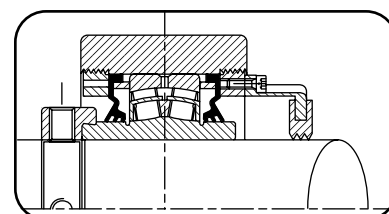

Fig. 17. Open-end urethane cover with DR seal.

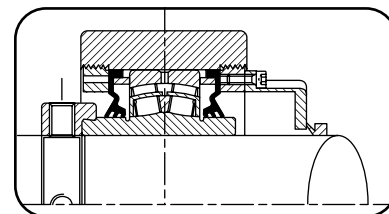

Fig. 18. Open-end urethane cover with VR seal.

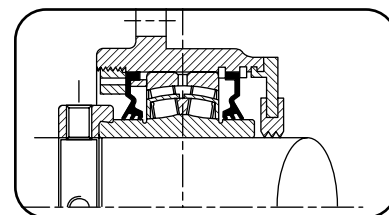

Fig. 19. HSY backing plate with DR seal.

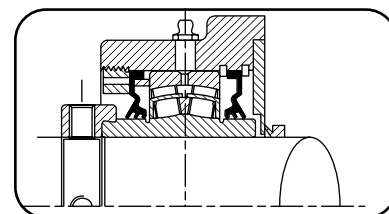

Fig. 20. UFP backing plate with VR seal.

STEEL AUXILIARY COVERS

Steel auxiliary covers bolt directly onto solid-block mounted spherical roller bearings. A DuPont Teflon labyrinth seal on the open-ended covers guards against shaft damage and gives protection at high running speeds. Made from steel to withstand the toughest applications, the covers are black-oxide treated for improved corrosion protection.

These covers are available in both open-ended and closed-ended designs for standard and custom configurations of Timken solid-block mounted spherical roller bearings.

Closed-End Covers (CS)

These bolt-on covers are designed to be virtually indestructible and extremely convenient. They are made from structural steel or urethane and are easy to install. The cover completely seals the bearing, preventing contamination from reaching the primary seal. Every cover is outfitted with a grease fitting to fill the cover cavity for an added barrier against contamination.



Fig. 21. Closed-end covers.

Open-End Covers (CJ/CK/CV)

These bolt-on covers are made from structural steel or urethane for repeated and continuous use. The covers are used with either a DuPont Teflon (T seal), triple-lip seal (DR) or a V-ring seal (VR) to help prevent contamination from reaching the primary seal. Every cover is outfitted with a grease fitting to fill the cover cavity for an added barrier against contamination.



Fig. 22. Open-end covers.

PILOTED FLANGE CARTRIDGE BACKING PLATES (HSY)

The HSY backing plate is designed to work in conjunction with the piloted flange cartridge mounted bearings. Made of structural urethane, these plates are fitted to the back side of the pilot for extra protection. The HSY plate comes supplied with a triple-lip seal (DR) or a contamination collar (optional) to form an additional barrier against contamination for the most demanding applications.



Fig. 23. Piloted flange cartridge backing plates.

FLANGE BLOCK BACKING PLATES (UFP)

These backing plates are made from structural urethane and are uniquely designed to work with our flange block mounted bearings. Made to fit flush against the back of the housing, these plates create a labyrinth over the inner ring for additional contamination protection. The UFP plate, when used with an optional V-ring seal (VR), provides an extra barrier against extreme contamination.



Fig. 24. Flange block backing plates.

HIGH-PERFORMANCE STEEL BACKING PLATE (BP)

These backing plates are made from mild steel and are uniquely designed to fit with our square flange block mounted bearings. These plates use dual Teflon seals to make 360° contact on the shaft to eliminate contamination into the flange side of the housing. The plate is placed on the shaft prior to mounting the flange block and mounts flush with the back of the housing secured by the mounting bolts.



Fig. 25. High-performance steel backing plates.

STEEL COVER DIMENSIONS

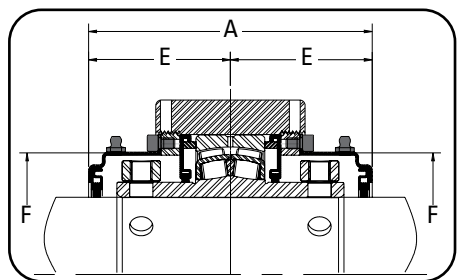

Fig. 26. Double open-end cover.⁽¹⁾

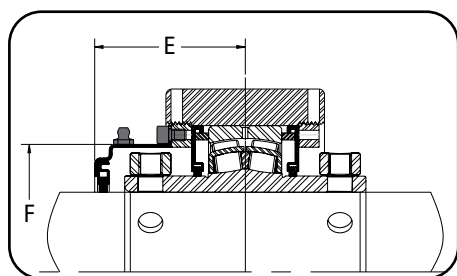

Fig. 27. Single open-end cover.

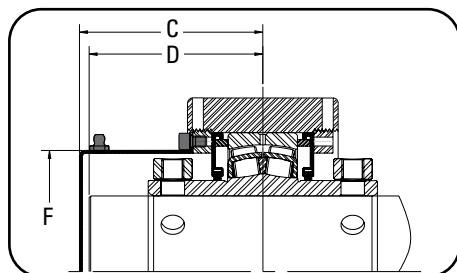

Fig. 28. Single closed-end cover.

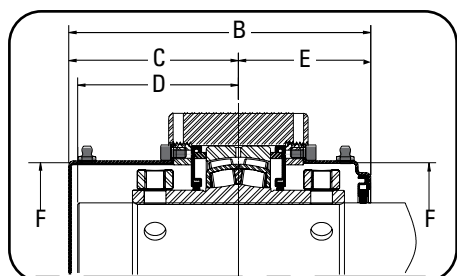

Fig. 29. Single closed-end cover and single open-end cover.⁽¹⁾

TABLE 2. V-LOCK SERIES – STRAIGHT BORE EQUIVALENTS

Cover Part No.	Shaft Dia.	Bearing No.	Steel Cover Dimensions					
			A	B	C	D	E	F
	mm in.		mm in.	mm in.	mm in.	mm in.	mm in.	mm in.
CS11STEEL	CLOSED	22211						
CV11T115S	1 1/16 in.		128.5	143.3	79.2	75.2	64.3	89.7
CV11T050S	50 mm		5.06	5.64	3.12	2.96	2.53	3.53
CV11T200S	2 in.	22212						
CS12STEEL	CLOSED							
CV12T055S	55 mm		129.0	141.5	77.0	72.9	64.5	98.6
CV12T203S	2 3/16 in.		5.08	5.57	3.03	2.87	2.54	3.88
CV12T204S	2 1/4 in.	22214						
CS14STEEL	CLOSED							
CV14T060S	60 mm		135.4	159.3	91.4	87.4	67.8	103.6
CV14T207S	2 7/16 in.		5.33	6.27	3.60	3.44	2.67	4.08
CV14T208S	2 1/2 in.	22216						
CV14T065S	65 mm							
CS16STEEL	CLOSED							
CV16T211S	2 11/16 in.							
CV16T212S	2 3/4 in.							
CV16T070S	70 mm		150.1	167.6	92.5	88.4	75.2	116.1
CV16T215S	2 15/16 in.		5.91	6.60	3.64	3.48	2.96	4.57
CV16T075S	75 mm	22219						
CV16T300S	3 in.							
CS19STEEL	CLOSED							
CV19T080S	80 mm							
CV19T303S	3 3/16 in.							
CV19T304S	3 1/4 in.							
CV19T085S	85 mm		167.9	191.0	106.9	102.9	84.1	139.4
CV19T307S	3 7/16 in.		6.61	7.52	4.21	4.05	3.31	5.49
CV19T308S	3 1/2 in.	22222						
CV19T090S	90 mm							
CS22STEEL	CLOSED							
CV22T311S	3 11/16 in.							
CV22T312S	3 3/4 in.							
CV22T100S	100 mm		217.7	241.8	133.1	129.0	109.0	180.1
CV22T315S	3 15/16 in.		8.57	9.52	5.24	5.08	4.29	7.09
CV22T400S	4 in.	22226						
CS26STEEL	CLOSED							
CV26T110S	110 mm							
CV26T407S	4 7/16 in.							
CV26T408S	4 1/2 in.							
CV26T115S	115 mm		219.7	242.8	133.1	129.0	110.0	209.3
CV26T115S	115 mm		8.65	9.56	5.24	5.08	4.33	8.24
CS28STEEL	CLOSED	22228						
CV28T125S	125 mm							
CV28T415S	4 15/16 in.							
CV28T500S	5 in.							
CV28T130S	130 mm		223.5	246.9	135.1	131.1	111.8	209.3
CV28T130S	130 mm		8.80	9.72	5.32	5.16	4.40	8.24

⁽¹⁾Double covers available only on pillow block and take-up style bearings.

TABLE 3. V-LOCK SERIES – TAPERED BORE EQUIVALENTS

Cover Part No.	Shaft Dia.	Bearing No.	Steel Cover Dimensions					
			A	B	C	D	E	F
	mm in.		mm in.	mm in.	mm in.	mm in.	mm in.	mm in.
CS11STEEL	CLOSED	22211	124.2 4.89	139.2 5.48	77.0 3.03	72.9 2.87	62.2 2.45	89.7 3.53
CV11T115S	1 1/16 in.							
CV11T050S	50 mm							
CV11T200S	2 in.	22213	130.3 5.13	154.2 6.07	88.9 3.50	84.8 3.34	65.3 2.57	103.6 4.08
CS13STEEL	CLOSED							
CV13T055S	55 mm							
CV13T203S	2 3/16 in.	22215	142.7 5.62	160.3 6.31	88.9 3.50	84.8 3.34	71.4 2.81	116.1 4.57
CV13T204S	2 1/4 in.							
CS15STEEL	CLOSED							
CV15T060S	60 mm	22217	133.9 5.27	156.0 6.14	88.9 3.50	84.8 3.34	67.1 2.64	132.1 5.2
CV15T207S	2 7/16 in.							
CV15T208S	2 1/2 in.							
CV15T065S	65 mm	22220	170.4 6.71	193.0 7.60	108.0 4.25	103.9 4.09	85.3 3.36	160.3 6.31
CS17STEEL	CLOSED							
CV17T211S	2 1/16 in.							
CV17T212S	2 3/4 in.	22217	133.9 5.27	156.0 6.14	88.9 3.50	84.8 3.34	67.1 2.64	132.1 5.2
CV17T070S	70 mm							
CV17T215S	2 15/16 in.							
CV17T075S	75 mm	22213	135.4 5.33	159.3 6.27	91.4 3.60	87.4 3.44	67.8 2.67	103.6 4.08
CV17T300S	3 in.							
CS20STEEL	CLOSED							
CV20T080S	80 mm	22215	148.1 5.83	165.6 6.52	91.4 3.60	87.4 3.44	74.2 2.92	116.1 4.57
CV20T303S	3 3/8 in.							
CV20T304S	3 1/4 in.							
CV20T085S	85 mm	22218	164.8 6.49	188.0 7.40	105.7 4.16	101.6 4.00	82.6 3.25	139.4 5.49
CV20T307S	3 7/16 in.							
CV20T308S	3 1/2 in.							
CV20T090S	90 mm	22224	213.6 8.41	237.7 9.36	131.1 5.16	127.0 5.00	106.7 4.20	180.1 7.09
CS22STEEL	CLOSED							
CV22T311S	3 1/16 in.							
CV22T312S	3 3/4 in.	22222	208.5 8.21	232.9 9.17	128.5 5.06	124.5 4.90	104.4 4.11	180.1 7.09
CV22T100S	100 mm							
CV22T315S	3 15/16 in.							
CV22T400S	4 in.	22226	210.6 8.29	233.9 9.21	128.5 5.06	124.5 4.90	105.4 4.15	209.3 8.24
CS24STEEL	CLOSED							
CV24T110S	110 mm							
CV26T110S	110 mm	22228	214.6 8.45	238.0 9.37	130.6 5.14	126.5 4.98	107.2 4.22	209.3 8.24
CV26T407S	4 7/16 in.							
CV26T408S	4 1/2 in.							
CV26T115S	115 mm	22226	219.7 8.65	242.8 9.56	133.1 5.24	129.0 5.08	110.0 4.33	209.3 8.24
CS28STEEL	CLOSED							
CV28T125S	125 mm							
CV28T415S	4 15/16 in.	22222	217.7 8.57	241.8 9.52	133.1 5.24	129.0 5.08	109.0 4.29	180.1 7.09
CV28T500S	5 in.							
CV28T130S	130 mm							

TABLE 4. CL SERIES – SINGLE AND DOUBLE SET SCREW LOCKS

Cover Part No.	Shaft Dia.	Bearing No.	Steel Cover Dimensions					
			A	B	C	D	E	F
	mm in.		mm in.	mm in.	mm in.	mm in.	mm in.	mm in.
CS08STEEL	CLOSED	22208	115.6 4.55	127.8 5.03	69.9 2.75	65.8 2.59	57.9 2.28	69.6 2.74
CA08T035S	35 mm							
CA08T107S	1 7/16 in.							
CA08T108S	1 1/2 in.	22209	121.7 4.79	130.8 5.15	69.9 2.75	65.8 2.59	61.0 2.40	74.7 2.94
CS09STEEL	CLOSED							
CA09T040S	40 mm							
CA09T111S	1 1/16 in.	22210	122.7 4.83	132.8 5.23	73.2 2.88	69.1 2.72	61.5 2.42	79.8 3.14
CA09T112S	1 3/4 in.							
CA09T045S	45 mm							
CS10STEEL	CLOSED	22211	128.5 5.06	143.3 5.64	79.2 3.12	75.2 2.96	64.3 2.53	89.7 3.53
CA10T115S	1 15/16 in.							
CA10T050S	50 mm							
CA10T200S	2 in.	22213	135.4 5.33	159.3 6.27	91.4 3.60	87.4 3.44	67.8 2.67	103.6 4.08
CS11STEEL	CLOSED							
CA11T055S	55 mm							
CA11T203S	2 3/16 in.	22215	148.1 5.83	165.6 6.52	91.4 3.60	87.4 3.44	74.2 2.92	116.1 4.57
CA11T204S	2 1/4 in.							
CS13STEEL	CLOSED							
CA13T060S	60 mm	22218	164.8 6.49	188.0 7.40	105.7 4.16	101.6 4.00	82.6 3.25	139.4 5.49
CA13T207S	2 7/16 in.							
CA13T208S	2 1/2 in.							
CA13T065S	65 mm	22220	179.6 7.07	202.2 7.96	112.5 4.43	108.5 4.27	89.9 3.54	160.3 6.31
CS15STEEL	CLOSED							
CA15T211S	2 1/16 in.							
CA15T212S	2 3/4 in.	22222	217.7 8.57	241.8 9.52	133.1 5.24	129.0 5.08	109.0 4.29	180.1 7.09
CA15T070S	70 mm							
CA15T215S	2 15/16 in.							
CA15T075S	75 mm	22226	219.7 8.65	242.8 9.56	133.1 5.24	129.0 5.08	110.0 4.33	209.3 8.24
CA15T300S	3 in.							
CS18STEEL	CLOSED							
CA18T080S	80 mm	22222	217.7 8.57	241.8 9.52	133.1 5.24	129.0 5.08	109.0 4.29	180.1 7.09
CA18T303S	3 3/16 in.							
CA18T304S	3 1/4 in.							
CA18T085S	85 mm	22226	219.7 8.65	242.8 9.56	133.1 5.24	129.0 5.08	110.0 4.33	209.3 8.24
CA18T307S	3 7/16 in.							
CA18T308S	3 1/2 in.							
CA18T090S	90 mm	22226	219.7 8.65	242.8 9.56	133.1 5.24	129.0 5.08	110.0 4.33	209.3 8.24
CS20STEEL	CLOSED							
CA20T311S	3 1/16 in.							
CA20T312S	3 3/4 in.	22222	217.7 8.57	241.8 9.52	133.1 5.24	129.0 5.08	109.0 4.29	180.1 7.09
CA20T100S	100 mm							
CA20T315S	3 15/16 in.							
CA20T400S	4 in.	22226	219.7 8.65	242.8 9.56	133.1 5.24	129.0 5.08	110.0 4.33	209.3 8.24
CS22STEEL	CLOSED							
CA22T110S	110 mm							
CA22T407S	4 7/16 in.	22222	217.7 8.57	241.8 9.52	133.1 5.24	129.0 5.08	109.0 4.29	180.1 7.09
CA22T408S	4 1/2 in.							
CA22T115S	115 mm							
CS26STEEL	CLOSED	22226	219.7 8.65	242.8 9.56	133.1 5.24	129.0 5.08	110.0 4.33	209.3 8.24
CA26T125S	125 mm							
CA26T415S	4 15/16 in.							
CA26T500S	5 in.	22226	219.7 8.65	242.8 9.56	133.1 5.24	129.0 5.08	110.0 4.33	209.3 8.24
CA26T130S	130 mm							

STEEL COVER DIMENSIONS – continued

TABLE 5. EC SERIES – ECCENTRIC LOCK

Cover Part No.	Shaft Dia.	Bearing No.	Steel Cover Dimensions					
			A	B	C	D	E	F
	mm in.		mm in.	mm in.	mm in.	mm in.	mm in.	mm in.
CS08STEEL	CLOSED	22208	115.6 4.55	127.8 5.03	69.9 2.75	65.8 2.59	57.9 2.28	69.6 2.74
CJ08T035S	35 mm							
CJ08T107S	1 7/16 in.							
CJ08T108S	1 1/2 in.	22209	121.7 4.79	130.8 5.15	69.9 2.75	65.8 2.59	61.0 2.40	74.7 2.94
CS09STEEL	Closed							
CJ09T040S	40 mm							
CJ09T111S	1 1/16 in.	22210	122.7 4.83	132.8 5.23	73.2 2.88	69.1 2.72	61.5 2.42	79.8 3.14
CJ09T112S	1 3/4 in.							
CJ09T045S	45 mm							
CS10STEEL	CLOSED	22211	128.5 5.06	143.3 5.64	79.2 3.12	75.2 2.96	64.3 2.53	89.7 3.53
CJ10T115S	1 5/16 in.							
CJ10T050S	50 mm							
CJ10T200S	2 in.	22213	135.4 5.33	159.3 6.27	91.4 3.60	87.4 3.44	67.8 2.67	103.6 4.08
CS11STEEL	CLOSED							
CJ11T055S	55 mm							
CJ11T203S	2 3/16 in.	22215	148.1 5.83	165.6 6.52	91.4 3.60	87.4 3.44	74.2 2.92	116.1 4.57
CJ11T204S	2 1/4 in.							
CS13STEEL	CLOSED							
CJ13T060S	60 mm	22218	164.8 6.49	188.0 7.40	105.7 4.16	101.6 4.00	82.6 3.25	139.4 5.49
CJ13T207S	2 7/16 in.							
CJ13T208S	2 1/2 in.							
CJ13T065S	65 mm	22220	179.6 7.07	202.2 7.96	112.5 4.43	108.5 4.27	89.9 3.54	160.3 6.31
CS15STEEL	CLOSED							
CJ15T211S	2 1/16 in.							
CJ15T212S	2 3/4 in.	22222	217.7 8.57	241.8 9.52	133.1 5.24	129.0 5.08	109.0 4.29	180.1 7.09
CJ15T070S	70 mm							
CJ15T215S	2 15/16 in.							
CJ15T075S	75 mm	22226	219.7 8.65	242.8 9.56	133.1 5.24	129.0 5.08	110.0 4.33	209.3 8.24
CJ15T300S	3 in.							
CS18STEEL	CLOSED							
CJ18T080S	80 mm	22230	270.3 10.64	283.2 11.15	148.1 5.83	144.0 5.67	135.1 5.32	239.5 9.43
CJ18T303S	3 3/16 in.							
CJ18T304S	3 1/4 in.							
CJ18T085S	85 mm	22234	300.5 11.83	305.3 12.02	155.2 6.11	151.1 5.95	150.1 5.91	279.4 11.00
CJ18T307S	3 7/16 in.							
CJ18T308S	3 1/2 in.							
CJ18T090S	90 mm	22226	219.7 8.65	242.8 9.56	133.1 5.24	129.0 5.08	110.0 4.33	209.3 8.24
CS20STEEL	CLOSED							
CJ20T311S	3 11/16 in.							
CJ20T312S	3 3/4 in.	22222	217.7 8.57	241.8 9.52	133.1 5.24	129.0 5.08	109.0 4.29	180.1 7.09
CJ20T100S	100 mm							
CJ20T315S	3 15/16 in.							
CJ20T400S	4 in.	22226	219.7 8.65	242.8 9.56	133.1 5.24	129.0 5.08	110.0 4.33	209.3 8.24
CS22STEEL	CLOSED							
CJ22T110S	110 mm							
CJ22T407S	4 7/16 in.	22230	270.3 10.64	283.2 11.15	148.1 5.83	144.0 5.67	135.1 5.32	239.5 9.43
CJ22T408S	4 1/2 in.							
CJ22T115S	115 mm							
CS26STEEL	CLOSED	22234	300.5 11.83	305.3 12.02	155.2 6.11	151.1 5.95	150.1 5.91	279.4 11.00
CJ26T125S	125 mm							
CJ26T415S	4 15/16 in.							
CJ26T500S	5 in.	22230	270.3 10.64	283.2 11.15	148.1 5.83	144.0 5.67	135.1 5.32	239.5 9.43
CJ26T130S	130 mm							
CS30STEEL	CLOSED							
CJ30T507S	5 7/16 in.	22234	300.5 11.83	305.3 12.02	155.2 6.11	151.1 5.95	150.1 5.91	279.4 11.00
CJ30T508S	5 1/2 in.							
CJ30T140S	140 mm							
CJ30T515S	5 15/16 in.	22234	300.5 11.83	305.3 12.02	155.2 6.11	151.1 5.95	150.1 5.91	279.4 11.00
CJ30T600S	6 in.							
CJ30T150S	150 mm							
CS34STEEL	CLOSED	22234	300.5 11.83	305.3 12.02	155.2 6.11	151.1 5.95	150.1 5.91	279.4 11.00
CJ34T607S	6 7/16 in.							
CJ34T608S	6 1/2 in.							
CJ34T170S	170 mm	22234	300.5 11.83	305.3 12.02	155.2 6.11	151.1 5.95	150.1 5.91	279.4 11.00
CJ34T615S	6 15/16 in.							
CJ34T700S	7 in.							
CJ34T180S	180 mm							

TABLE 6. TA/DV SERIES – TAPERED ADAPTER LOCK

Cover Part No.	Shaft Dia.	Bearing No.	Steel Cover Dimensions					
			A	B	C	D	E	F
	mm in.		mm in.	mm in.	mm in.	mm in.	mm in.	mm in.
CS09STEEL	CLOSED	22209	118.4 4.66	127.5 5.02	68.3 2.69	64.3 2.53	59.2 2.33	74.7 2.94
CK09T107S	1 7/16 in.							
CK09T108S	1 1/2 in.							
CK09T040S	40 mm							
CS10STEEL	CLOSED	22210	118.4 4.66	130.0 5.12	70.9 2.79	66.8 2.63	59.2 2.33	79.8 3.14
CK10T111S	1 11/16 in.							
CK10T112S	1 3/4 in.							
CK10T045S	45 mm							
CS11STEEL	CLOSED	22211	124.2 4.89	139.2 5.48	77.0 3.03	72.9 2.87	62.2 2.45	89.7 3.53
CK11T115S	1 15/16 in.							
CK11T050S	50 mm							
CK11T200S	2 in.							
CS12STEEL	CLOSED	22212	123.7 4.87	136.4 5.37	74.4 2.93	70.4 2.77	62.0 2.44	98.6 3.88
CK12T055S	55 mm							
CS13STEEL	CLOSED							
CK13T203S	2 3/16 in.							
CK13T204S	2 1/4 in.	22213	130.3 5.13	154.2 6.07	88.9 3.50	84.8 3.34	65.3 2.57	103.6 4.08
CK13T060S	60 mm							
CS15STEEL	CLOSED							
CK15T207S	2 7/16 in.							
CK15T208S	2 1/2 in.	22215	142.7 5.62	160.3 6.31	88.9 3.50	84.8 3.34	71.4 2.81	116.1 4.57
CK15T065S	65 mm							
CS16STEEL	CLOSED							
CK16T211S	2 11/16 in.							
CK16T212S	2 3/4 in.	22216	144.8 5.70	162.3 6.39	89.9 3.54	85.9 3.38	72.4 2.85	116.1 4.57
CK16T070S	70 mm							
CS17STEEL	CLOSED							
CK17T215S	2 15/16 in.							
CK17T075S	75 mm	22217	133.9 5.27	156.0 6.14	88.9 3.50	84.8 3.34	67.1 2.64	132.1 5.20
CK17T300S	3 in.							
CS18STEEL	CLOSED							
CK18T080S	80 mm							
CK18T303S	3 3/16 in.	22218	159.5 6.28	182.9 7.20	102.9 4.05	98.8 3.89	79.8 3.14	139.4 5.49
CK18T304S	3 1/4 in.							
CS19STEEL	CLOSED							
CK19T085S	85 mm							
CK19T085S	85 mm	22219	162.6 6.40	185.7 7.31	104.4 4.11	100.3 3.95	81.3 3.20	139.4 5.49

Cover Part No.	Shaft Dia.	Bearing No.	Steel Cover Dimensions					
			A	B	C	D	E	F
	mm in.		mm in.	mm in.	mm in.	mm in.	mm in.	mm in.
CS20STEEL	CLOSED	22220	170.4 6.71	193.0 7.60	108.0 4.25	103.9 4.09	85.3 3.36	160.3 6.31
CK20T307S	3 7/16 in.							
CK20T308S	3 1/2 in.							
CK20T090S	90 mm							
CS22STEEL	CLOSED	22222	208.5 8.21	232.9 9.17	128.5 5.06	124.5 4.90	104.4 4.11	180.1 7.09
CK22T315S	3 15/16 in.							
CK22T400S	4 in.							
CK22T100S	100 mm							
CS24STEEL	CLOSED	22224	213.6 8.41	237.7 9.36	131.1 5.16	127.0 5.00	106.7 4.20	180.1 7.09
CK24T403S	4 3/16 in.							
CK24T404S	4 1/4 in.							
CK24T110S	110 mm							
CS26STEEL	CLOSED	22226	210.6 8.29	233.9 9.21	128.5 5.06	124.5 4.90	105.4 4.15	209.3 8.24
CK26T407S	4 7/16 in.							
CK26T408S	4 1/2 in.							
CK26T115S	115 mm							
CS28STEEL	CLOSED	22228	214.6 8.45	238.0 9.37	130.6 5.14	126.5 4.98	107.2 4.22	209.3 8.24
CK28T415S	4 15/16 in.							
CK28T500S	5 in.							
CK28T125S	125 mm							

STEEL COVER DIMENSIONS – continued

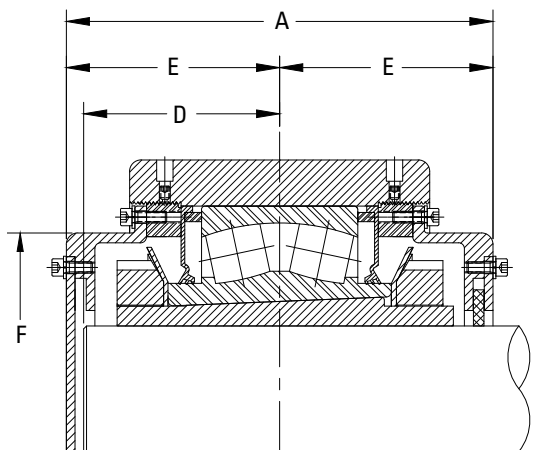

TABLE 7. TAA/DAA SERIES – TAPERED ADAPTER LOCK

Cover Part No.	Shaft Dia.	Bearing No.	Steel Cover Dimensions			
			A	D	E	F
	mm in.		mm in.	mm in.	mm in.	mm in.
CS32STEEL	CLOSED	23132	235.1 9.26	108.2 4.26	117.6 4.63	240.5 9.47
CK32T135S	135 mm					
CK32T506S	5 3/8 in.					
CK32T507S	5 7/16 in.					
CK32T508S	5 1/2 in.					
CK32T140S	140 mm	23134	236.6 9.32	108.7 4.28	118.3 4.66	243.4 9.58
CS34LSTEEL	CLOSED					
CK34T513S	5 13/16 in.					
CK34T514S	5 7/8 in.					
CK34T150S	150 mm					
CK34T515S	5 15/16 in.	23136	237.1 9.34	107.0 4.21	118.6 4.67	255.9 10.08
CK34T600S	6 in.					
CS36STEEL	CLOSED					
CK36T160S	160 mm					
CK36T605S	6 5/16 in.					
CK36T606S	6 3/8 in.	23138	255.4 10.06	118.1 4.65	127.7 5.03	272.3 10.72
CK36T607S	6 7/16 in.					
CK36T608S	6 1/2 in.					
CS38STEEL	CLOSED					
CK38T170S	170 mm					
CK38T613S	6 13/16 in.	23160	377.5 14.86	170.6 6.71	188.8 7.43	432.8 17.04
CK38T614S	6 7/8 in.					
CK38T615S	6 15/16 in.					
CK38T700S	7 in.					

Cover Part No.	Shaft Dia.	Bearing No.	Steel Cover Dimensions			
			A	D	E	F
	mm in.		mm in.	mm in.	mm in.	mm in.
CS40STEEL	CLOSED	23140	258.8 10.19	119.4 4.70	129.4 5.09	287.4 11.31
CK40T180S	180 mm					
CK40T702S	7 1/8 in.					
CK40T703S	7 3/16 in.					
CK40T704S	7 1/4 in.					
CS44STEEL	CLOSED	23144	297.7 11.72	136.1 5.36	148.9 5.86	314.0 12.36
CK44T713S	7 13/16 in.					
CK44T200S	200 mm					
CK44T714S	7 7/8 in.					
CK44T715S	7 15/16 in.					
CK44T800S	8 in.	23148	300.0 11.81	136.7 5.38	150.0 5.91	346.4 13.64
CS48STEEL	CLOSED					
CK48T807S	8 7/16 in.					
CK48T808S	8 1/2 in.					
CK48T220S	220 mm					
CK48T815S	8 15/16 in.	23152	330.0 12.99	151.0 5.95	165.0 6.50	381.0 15.00
CK48T900S	9 in.					
CS52STEEL	CLOSED					
CK52T907S	9 7/16 in.					
CK52T240S	240 mm					
CK52T908S	9 1/2 in.	23156	365.2 14.38	167.0 6.58	182.6 7.19	388.4 15.29
CS56STEEL	CLOSED					
CK56T915S	9 15/16 in.					
CK56T1000S	10 in.					
CK56T260S	260 mm					
CK56T1007S	10 7/16 in.	23160	377.5 14.86	170.6 6.71	188.8 7.43	432.8 17.04
CK56T1008S	10 1/2 in.					
CS60STEEL	CLOSED					
CK60T1015S	10 15/16 in.					
CK60T1100S	11 in.					
CK60T280S	280 mm	23164	390.5 15.37	176.7 6.96	195.2 7.69	450.8 17.75
CS64STEEL	CLOSED					
CK64T1107S	11 7/16 in.					
CK64T1108S	11 1/2 in.					
CK64T300S	300 mm					
CK64T1115S	11 15/16 in.	23164	390.5 15.37	176.7 6.96	195.2 7.69	450.8 17.75
CK64T1200S	12 in.					

Continued on next page.

TABLE 7. TAA/DAA SERIES – TAPERED ADAPTER LOCK (CONTINUED)

Cover Part No.	Shaft Dia.	Bearing No.	Steel Cover Dimensions			
			A	D	E	F
	mm in.		mm in.	mm in.	mm in.	mm in.
CS68STEEL	CLOSED	23168	412.6 16.24	185.2 7.29	206.3 8.12	482.1 18.98
CK68T1207S	12 7/16 in.					
CK68T1208S	12 1/2 in.					
CK68T320S	320 mm	23172	435.2 17.13	196.8 7.75	217.6 8.57	521.6 20.54
CS72STEEL	CLOSED					
CK72T1215S	12 15/16 in.					
CK72T1300S	13 in.					
CK72T340S	340 mm					
CK72T1307S	13 7/16 in.					
CK72T1308S	13 1/2 in.					
CS76STEEL	CLOSED	23176	458.9 18.07	204.2 8.04	229.5 9.03	554.3 21.82
CK76T1315S	13 15/16 in.					
CK76T1400S	14 in.					
CK76T360S	360 mm	23180	482.1 18.98	215.6 8.49	241.1 9.49	582.6 22.94
CS80STEEL	CLOSED					
CK80T1415S	14 15/16 in.					
CK80T380S	380 mm					
CK80T1500S	15 in.					

URETHANE

CLOSED-END COVER DIMENSIONS

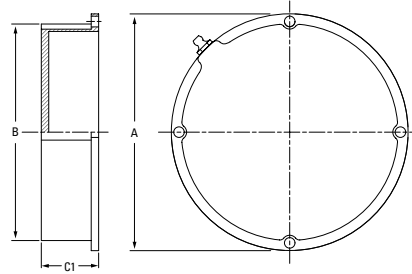

TABLE 8. CLOSED-END COVER DIMENSIONS

Cover Part No. ⁽¹⁾	A	B	C1 ⁽²⁾
	mm in.	mm in.	mm in.
CS08	81.5 3.21	76.7 3.02	31.6 1.25
CS09	86.6 3.41	81.6 3.21	31.6 1.25
CS10	91.9 3.62	86.6 3.41	31.6 1.25
CS11	101.9 4.01	96.6 3.81	31.6 1.25
CS12V	110.5 4.35	105.6 4.16	31.6 1.25
CS13/CS14V	119.4 4.70	110.5 4.35	27.3 1.08
CS15/CS16V	130.0 5.12	122.9 4.84	33.0 1.30
CS17	149.9 5.90	139.0 5.47	31.1 1.22
CS18/CS19V	160.3 6.31	146.5 5.77	38.8 1.53
CS20	179.8 7.08	167.2 6.58	44.5 1.75
CS22	200.4 7.89	187.2 7.37	52.7 2.07
CS24	200.4 7.89	187.2 7.37	52.7 2.07
CS26/CS28V	230.1 9.06	216.2 8.51	56.9 2.24
CS30	270.5 10.65	254.0 10.00	56.9 2.24
CS30L	248.4 9.78	221.2 8.71	31.2 1.23
CS32	270.0 10.63	240.5 9.47	33.5 1.32
CS34	309.9 12.20	295.2 11.62	73.3 2.89
CS34L	280.0 11.02	243.4 9.58	31.5 1.24
CS36	295.4 11.63	255.9 10.08	31.5 1.24
CS38	316.1 12.45	272.3 10.72	32.5 1.28
CS40	335.2 13.20	272.3 10.72	32.5 1.28
CS44	367.0 14.45	314.0 12.36	41.4 1.63

⁽¹⁾Cover part number, CSXX, is determined by the bearing insert series of unit on which cover will be installed. See nomenclature guide on page 12 to determine bearing insert series.

⁽²⁾Extended covers available upon request.

URETHANE – continued

OPEN-END COVERS WITH DR SEALS

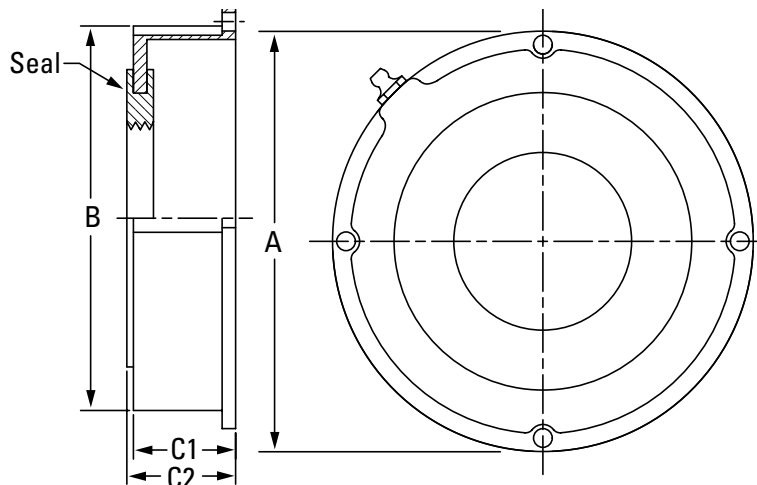

TABLE 9. V-LOCK SERIES – STRAIGHT BORE EQUIVALENT – OPEN-END COVER WITH DR SEAL – (QV[V]...P, PL, SN, PF, PR, C, CW, F, FL, FY, FX, TU)

Cover Part No.	Shaft Dia.	A	B	C1	C2
	mm in.	mm in.	mm in.	mm in.	mm in.
CVDR11-115	1 1/16 in.	101.9	96.6	31.6	34.2
CVDR11-200	2 in.				
CVDR11-050MM	50 mm	4.01	3.81	1.25	1.35
CVDR12-203	2 3/16 in.	110.5	105.6	31.6	34.2
CVDR12-204	2 1/4 in.				
CVDR12-055MM	55 mm	4.35	4.16	1.25	1.35
CVDR14-060MM	60 mm	119.4	110.5	27.3	29.8
CVDR14-207	2 7/16 in.				
CVDR14-208	2 1/2 in.	4.70	4.35	1.08	1.18
CVDR14-065MM	65 mm	130.0	122.9	33.0	35.5
CVDR16-211	2 11/16 in.				
CVDR16-212	2 3/4 in.	5.12	4.84	1.30	1.40
CVDR16-070MM	70 mm	160.3	146.5	38.8	41.4
CVDR16-215	2 15/16 in.				
CVDR16-300	3 in.	6.31	5.77	1.53	1.63
CVDR16-075MM	75 mm	200.4	187.2	52.7	55.2
CVDR19-303	3 3/16 in.				
CVDR19-304	3 1/4 in.	7.89	7.37	2.07	2.17
CVDR19-080MM	80 mm	230.1	216.2	56.9	59.4
CVDR19-085MM	85 mm				
CVDR19-307	3 7/16 in.	9.06	8.51	2.24	2.34
CVDR19-308	3 1/2 in.	230.1	216.2	56.9	59.4
CVDR19-090MM	90 mm				
CVDR22-311	3 11/16 in.	200.4	187.2	52.7	55.2
CVDR22-312	3 3/4 in.				
CVDR22-100MM	100 mm	7.89	7.37	2.07	2.17
CVDR22-315	3 15/16 in.	230.1	216.2	56.9	59.4
CVDR22-400	4 in.				
CVDR26-110MM	110 mm	9.06	8.51	2.24	2.34
CVDR26-407	4 7/16 in.	230.1	216.2	56.9	59.4
CVDR26-408	4 1/2 in.				
CVDR26-115MM	115 mm	9.06	8.51	2.24	2.34
CVDR28-125MM	125 mm	230.1	216.2	56.9	59.4
CVDR28-415	4 15/16 in.				
CVDR28-500	5 in.	9.06	8.51	2.24	2.34
CVDR28-130MM	130 mm				

TABLE 10. V-LOCK SERIES – TAPERED ADAPTER EQUIVALENT – OPEN-END COVER WITH DR SEAL – (QV[V]...PA, PN, PKT, PK, PH, PG, FC, FB, MC)

Cover Part No.	Shaft Dia.	A	B	C1	C2
	mm in.	mm in.	mm in.	mm in.	mm in.
CVDR11-115	1 1/16 in.	101.9	96.6	31.6	34.2
CVDR11-200	2 in.				
CVDR11-050MM	50 mm	4.01	3.81	1.25	1.35
CVDR13-203	2 3/16 in.	119.4	110.5	27.3	29.8
CVDR13-204	2 1/4 in.				
CVDR13-055MM	55 mm	4.70	4.35	1.08	1.18
CVDR15-060MM	60 mm	130.0	122.9	33.0	35.5
CVDR15-207	2 7/16 in.				
CVDR15-208	2 1/2 in.	5.12	4.84	1.30	1.40
CVDR15-065MM	65 mm	149.9	139.0	31.1	33.6
CVDR17-211	2 11/16 in.				
CVDR17-212	2 3/4 in.	5.90	5.47	1.22	1.32
CVDR17-070MM	70 mm	179.8	167.2	44.5	47.0
CVDR17-215	2 15/16 in.				
CVDR17-300	3 in.	7.08	6.58	1.75	1.85
CVDR16-075MM	75 mm	200.4	187.2	52.7	55.2
CVDR20-303	3 3/16 in.				
CVDR20-304	3 1/4 in.	7.89	7.37	2.07	2.17
CVDR20-080MM	80 mm	230.1	216.2	56.9	59.4
CVDR20-085MM	85 mm				
CVDR20-307	3 7/16 in.	9.06	8.51	2.24	2.34
CVDR19-308	3 1/2 in.	230.1	216.2	56.9	59.4
CVDR19-090MM	90 mm				
CVDR22-311	3 11/16 in.	200.4	187.2	52.7	55.2
CVDR22-312	3 3/4 in.				
CVDR22-100MM	100 mm	7.89	7.37	2.07	2.17
CVDR22-315	3 15/16 in.	230.1	216.2	56.9	59.4
CVDR22-400	4 in.				
CVDR26-110MM	110 mm	9.06	8.51	2.24	2.34
CVDR26-407	4 7/16 in.	230.1	216.2	56.9	59.4
CVDR26-408	4 1/2 in.				
CVDR26-115MM	115 mm	9.06	8.51	2.24	2.34
CVDR28-125MM	125 mm	230.1	216.2	56.9	59.4
CVDR28-415	4 15/16 in.				
CVDR28-500	5 in.	9.06	8.51	2.24	2.34
CVDR28-130MM	130 mm				

OPEN-END COVERS WITH DR SEALS

TABLE 11. CL AND EC SERIES – OPEN-END COVER WITH DR SEAL

Cover Part No.	Shaft Dia.	A	B	C1	C2
	mm in.	mm in.	mm in.	mm in.	mm in.
CJDR035MM	35 mm				
CJDR107	1 7/16 in.	97.0	76.7	31.8	34.3
CJDR108	1 1/2 in.	3.82	3.02	1.25	1.35
CJDR040MM	40 mm				
CJDR111	1 11/16 in.	101.9	81.6	31.8	34.3
CJDR112	1 3/4 in.	4.01	3.21	1.25	1.35
CJDR045MM	45 mm				
CJDR115	1 5/8 in.	106.9	86.6	31.8	34.3
CJDR200	2 in.	4.21	3.41	1.25	1.35
CJDR050MM	50 mm				
CJDR203	2 3/16 in.	117.1	96.8	31.8	34.3
CJDR204	2 1/4 in.	4.61	3.81	1.25	1.35
CJDR055MM	55 mm				
CJDR060MM	60 mm				
CJDR207	2 7/16 in.	132.1	110.49	27.4	30.0
CJDR208	2 1/2 in.	5.20	4.35	1.08	1.18
CJDR065MM	65 mm				
CJDR211	2 1/8 in.	142	122.9	33.0	35.6
CJDR070MM	70 mm				
CJDR212	2 3/4 in.	5.59	4.84	1.30	1.40
CJDR215	2 5/8 in.				
CJDR300	3 in.				
CJDR075MM	75 mm				
CJDR303	3 3/16 in.	168.1	149.1	38.9	41.4
CJDR304	3 1/4 in.	6.62	5.87	1.53	1.63
CJDR080MM	80 mm				
CJDR085MM	85 mm				
CJDR307	3 7/16 in.				
CJDR308	3 1/2 in.				
CJDR090MM	90 mm				
CJDR315	3 15/16 in.	192	174.8	44.5	47.0
CJDR400	4 in.	7.56	6.88	1.75	1.85
CJDR100MM	100 mm				
CJDR110MM	110 mm				
CJDR407	4 7/16 in.	212.1	194.8	52.6	55.1
CJDR408	4 1/2 in.	8.35	7.67	2.07	2.17
CJDR115MM	115 mm				
CJDR125MM	125 mm				
CJDR415	4 15/16 in.	241.3	223.8	56.9	59.4
CJDR500	5 in.	9.50	8.81	2.24	2.34
CJDR130MM	130 mm				
CJDR507	5 7/16 in.				
CJDR508	5 1/2 in.				
CJDR140MM	140 mm				
CJDR515	5 15/16 in.	271.6	254.0	56.9	59.4
CJDR600	6 in.	10.69	10.00	2.24	2.34
CJDR150MM	150 mm				
CJDR607	6 7/16 in.				
CJDR608	6 1/2 in.				
CJDR170MM	170 mm				
CJDR615	6 15/16 in.	304.8	287.3	56.9	59.4
CJDR700	7 in.	12.00	11.31	2.24	2.34
CJDR180MM	180 mm				

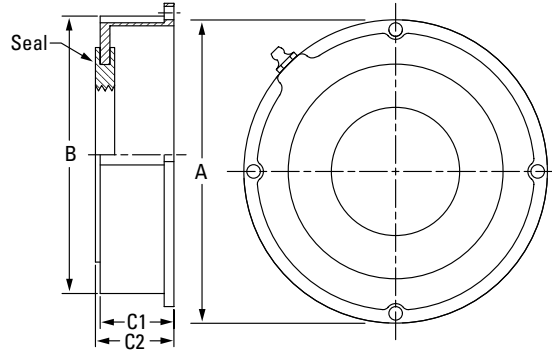

TABLE 12. TA/DV SERIES – OPEN-END COVER WITH DR SEAL

Cover Part No.	Shaft Dia.	A	B	C1	C2
	mm in.	mm in.	mm in.	mm in.	mm in.
CKDR107	1 7/16 in.	86.6	81.5	31.8	34.3
CKDR108	1 1/2 in.	3.41	3.21	1.25	1.35
CKDR040MM	40 mm				
CKDR111	1 11/16 in.	92.7	86.6	31.8	34.3
CKDR112	1 3/4 in.	3.65	3.41	1.25	1.35
CKDR045MM	45mm				
CKDR115	1 5/8 in.	101.9	96.8	31.8	34.3
CKDR200	2 in.	4.01	3.81	1.25	1.35
CKDR050MM	50 mm				
CKDR055MM	55 mm				
CKDR203	2 3/16 in.	111.8	105.7	31.8	34.3
CKDR204	2 1/4 in.	4.40	4.16	1.25	1.35
CKDR060MM	60 mm	119.4	116.1	27.4	30.0
CKDR207	2 7/16 in.	4.70	4.57	1.08	1.18
CKDR208	2 1/2 in.	130.0	122.9	33.0	35.6
CKDR065MM	65 mm	5.12	4.84	1.30	1.40
CKDR211	2 1/8 in.	160.3	149.1	38.9	41.4
CKDR212	2 3/4 in.	6.31	5.87	1.53	1.63
CKDR070MM	70 mm	130.0	122.9	33.0	35.6
CKDR215	2 5/8 in.	5.12	4.84	1.30	1.40
CKDR300	3 in.	149.9	141.5	31.0	33.5
CKDR075MM	75 mm	5.90	5.57	1.22	1.32
CKDR080MM	80 mm				
CKDR303	3 3/16 in.	160.3	149.1	38.9	41.4
CKDR304	3 1/4 in.	6.31	5.87	1.53	1.63
CKDR085MM	85 mm	160.3	149.1	38.9	41.4
CKDR307	3 7/16 in.	6.31	5.87	1.53	1.63
CKDR308	3 1/2 in.	179.8	174.8	44.5	47.0
CKDR090MM	90 mm	7.08	6.88	1.75	1.85
CKDR315	3 15/16 in.				
CKDR400	4 in.	200.4	194.8	52.6	55.1
CKDR100MM	100 mm	7.89	7.67	2.07	2.17
CKDR403	4 3/16 in.				
CKDR404	4 1/4 in.	200.4	194.8	52.6	55.1
CKDR110MM	110 mm	7.89	7.67	2.07	2.17
CKDR407	4 7/16 in.				
CKDR408	4 1/2 in.	230.1	223.8	56.9	59.4
CKDR115MM	115 mm	9.06	8.81	2.24	2.34
CKDR415	4 15/16 in.				
CKDR500	5 in.	230.1	223.8	56.9	59.4
CKDR125MM	125 mm	9.06	8.81	2.24	2.34

Continued on next page.

URETHANE – *continued*

OPEN-END COVERS WITH DR SEALS

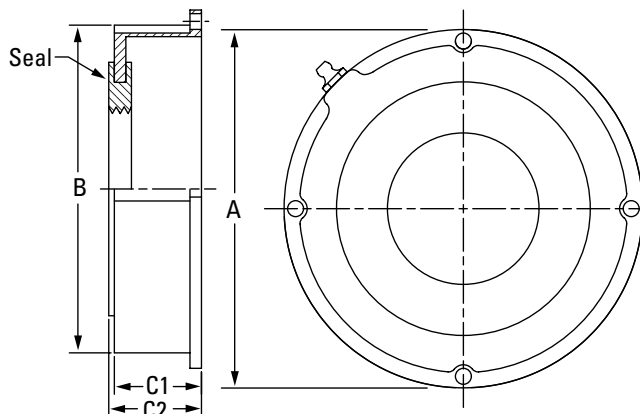

**TABLE 12. TA/DV SERIES – OPEN-END COVER WITH DR SEAL
(CONTINUED)**

Cover Part No.	Shaft Dia.	A	B	C1	C2
		mm in.	mm in.	mm in.	mm in.
CKDR503	5 3/16 in.	248.4 9.78	221.2 8.71	31.2 1.23	33.8 1.33
CKDR504	5 1/4 in.				
CKDR135MM	135 mm				
CKDR506	5 3/8 in.	270.0 10.63	240.5 9.47	33.5 1.32	36.1 1.42
CKDR507	5 7/16 in.				
CKDR508	5 1/2 in.				
CKDR140MM	140 mm				
CKDR513	5 13/16 in.	280.0 11.02	243.4 9.58	31.5 1.24	34.0 1.34
CKDR514	5 7/8 in.				
CKDR515	5 15/16 in.				
CKDR600	6 in.	295.4 11.63	255.9 10.08	31.5 1.24	34.0 1.34
CKDR150MM	150 mm				
CKDR605	6 3/16 in.				
CKDR606	6 3/8 in.				
CKDR607	6 7/16 in.				
CKDR608	6 1/2 in.				
CKDR160MM	160 mm				
CKDR613	6 13/16 in.	316.1 12.45	272.3 10.72	32.5 1.28	35.1 1.38
CKDR614	6 7/8 in.				
CKDR615	6 15/16 in.				
CKDR700	7 in.	335.2 13.20	286.8 11.29	38.3 1.51	40.9 1.61
CKDR170MM	170 mm				
CKDR702	7 1/8 in.				
CKDR703	7 3/16 in.				
CKDR704	7 1/4 in.				
CKDR180MM	180 mm				
CKDR713	7 13/16 in.	367.0 14.45	314.0 12.36	41.4 1.63	43.9 1.73
CKDR714	7 7/8 in.				
CKDR715	7 15/16 in.				
CKDR800	8 in.				
CKDR200MM	200 mm				

OPEN-END COVERS WITH VR SEALS

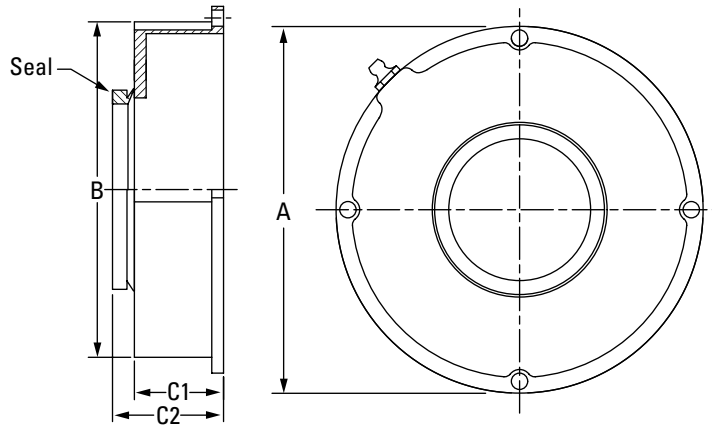

TABLE 13. V-LOCK SERIES – STRAIGHT BORE EQUIVALENT – OPEN-END COVER WITH VR SEAL – (QV[V]...P, PL, SN, PF, PR, PX, PXT, C, CW, F, FL, FY, FX, TU)

Cover Part No. ⁽¹⁾	Shaft Dia.	A	B	C1	C2
	mm in.	mm in.	mm in.	mm in.	mm in.
CVVR11	1 15/16 in.	117.1 4.61	96.8 3.81	31.8 1.25	40.6 1.60
	2 in.				
	50 mm				
CVVR12	2 3/16 in.	126.0 4.96	105.7 4.16	31.8 1.25	40.6 1.60
	2 1/4 in.				
	55 mm				
CVVR14	2 7/16 in.	132.1 5.20	116.1 4.57	27.4 1.08	36.3 1.43
	2 1/2 in.				
	65 mm				
CVVR16	2 11/16 in.	142.0 5.59	122.9 4.84	33.0 1.30	44.0 1.73
	2 3/4 in.				
	70 mm				
	2 15/16 in.				
CVVR19	3 in.	168.1 6.62	149.1 5.87	38.9 1.53	50.0 1.96
	75 mm				
	3 3/16 in.				
	3 1/4 in.				
	80 mm				
CVVR22	3 7/16 in.	212.1 8.35	194.8 7.67	52.6 2.07	63.5 2.50
	3 1/2 in.				
	90 mm				
	3 11/16 in.				
CVVR26	3 3/4 in.	241.3 9.50	223.8 8.81	56.9 2.24	69.6 2.74
	100 mm				
	4 1/16 in.				
	4 1/2 in.				
CVVR28	110 mm	241.3 9.50	223.8 8.81	56.9 2.24	69.6 2.74
	4 7/16 in.				
	4 1/2 in.				
	115 mm				
CVVR28	125 mm	241.3 9.50	223.8 8.81	56.9 2.24	69.6 2.74
	4 15/16 in.				
	5 in.				
	130 mm				

⁽¹⁾Please refer to bore size when choosing cover for straight-bore V-Lock.

TABLE 14. V-LOCK SERIES – TAPERED ADAPTER EQUIVALENT – OPEN-END COVER WITH VR SEAL – (QV[V]...PA, PN, PKT, PK, PH, PG, FC, FB, MC)

Cover Part No.	Shaft Dia.	A	B	C1	C2
	mm in.	mm in.	mm in.	mm in.	mm in.
CKVR11	1 15/16 in.	117.1 4.61	96.8 3.81	31.8 1.25	40.6 1.60
	2 in.				
	50 mm				
CKVR13	2 3/16 in.	132.1 5.20	116.1 4.57	27.4 1.08	36.3 1.43
	2 1/4 in.				
	55 mm				
CKVR15	2 7/16 in.	142.0 5.59	122.9 4.84	33.0 1.30	41.9 1.65
	2 1/2 in.				
	65 mm				
CKVR17	2 11/16 in.	160.6 6.32	141.5 5.57	31.0 1.22	41.9 1.65
	2 3/4 in.				
	70 mm				
	2 15/16 in.				
CKVR20	3 in.	192.0 7.56	174.8 6.88	44.4 1.75	55.4 2.18
	75 mm				
	3 3/16 in.				
	3 1/4 in.				
	80 mm				
CKVR22	3 7/16 in.	212.1 8.35	194.8 7.67	52.6 2.07	63.5 2.50
	3 1/2 in.				
	90 mm				
	3 11/16 in.				
CKVR24	3 3/4 in.	212.1 8.35	194.8 7.67	52.6 2.07	63.5 2.5
	100 mm				
	4 1/16 in.				
	4 1/2 in.				
CKVR26	110 mm	241.3 9.50	223.8 8.81	56.9 2.24	69.6 2.74
	4 7/16 in.				
	4 1/2 in.				
	115 mm				
CKVR28	125 mm	241.3 9.50	223.8 8.81	56.9 2.24	69.6 2.74
	4 15/16 in.				
	5 in.				
	130 mm				

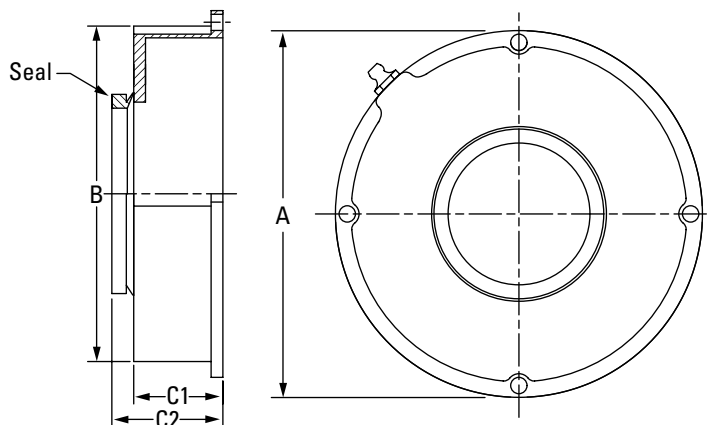

TABLE 15. CL AND EC SERIES – OPEN-END COVER WITH VR SEAL

Cover Part No.	Shaft Dia.	A	B	C1	C2
	mm in.	mm in.	mm in.	mm in.	mm in.
CJVR08	35 mm	97.0	76.7	31.8	39.4
	1 7/16 in.				
	1 1/2 in.				
CJVR09	40 mm	101.9	81.5	31.8	40.6
	1 11/16 in.				
	1 3/4 in.				
CJVR10	45 mm	106.9	86.6	31.8	40.6
	1 15/16 in.				
	2 in.				
CJVR11	50 mm	117.1	96.8	31.8	40.6
	2 3/16 in.				
	2 1/4 in.				
CJVR13	55 mm	132.1	116.1	27.4	36.3
	60 mm				
	2 3/8 in.				
CJVR15	65 mm	142.0	122.9	33.0	44.0
	70 mm				
	2 7/8 in.				
	2 9/16 in.				
	3 in.				
CJVR18	75 mm	168.1	149.1	38.9	49.8
	80 mm				
	85 mm				
	3 3/16 in.				
	3 1/4 in.				
CJVR20	90 mm	192.0	174.8	44.5	55.4
	100 mm				
	3 15/16 in.				
CJVR22	110 mm	212.1	194.8	52.6	65.3
	115 mm				
	4 1/2 in.				
CJVR26	125 mm	241.3	223.8	56.9	69.6
	4 15/16 in.				
	5 in.				

TABLE 16. TA/DV SERIES – OPEN-END COVER WITH VR SEAL

Cover Part No.	Shaft Dia.	A	B	C1	C2
	mm in.	mm in.	mm in.	mm in.	mm in.
CKVR09	1 7/16 in.	101.9	81.5	31.8	39.4
	1 1/2 in.				
CKVR10	40 mm	106.9	86.6	31.8	40.6
	1 11/16 in.				
	1 3/4 in.				
CKVR11	45 mm	117.1	96.8	31.8	40.6
	1 15/16 in.				
	2 in.				
CKVR12	50 mm	126.0	105.7	31.8	40.6
	55 mm				
CKVR13	60 mm	132.1	116.1	27.4	36.3
	65 mm				
	2 3/8 in.				
CKVR15	70 mm	142.0	122.9	33.0	41.9
	75 mm				
	2 7/8 in.				
CKVR16	80 mm	142.0	122.9	33.0	41.9
	85 mm				
	2 3/4 in.				
CKVR17	90 mm	160.5	141.5	31.0	41.9
	95 mm				
	3 in.				
CKVR18	100 mm	168.1	149.1	38.9	49.8
	105 mm				
	3 3/16 in.				
CKVR19	110 mm	168.1	149.1	38.9	49.8
	115 mm				
	3 1/4 in.				
CKVR20	125 mm	192.0	174.8	44.5	55.4
	130 mm				
	3 7/16 in.				
CKVR22	140 mm	212.1	194.8	52.6	63.5
	145 mm				
	4 in.				
CKVR24	155 mm	212.1	194.8	52.6	63.5
	160 mm				
	4 3/16 in.				
CKVR26	170 mm	241.3	223.8	56.9	69.6
	175 mm				
	4 7/16 in.				
CKVR28	185 mm	241.3	223.8	56.9	69.6
	190 mm				
	4 1/2 in.				

UFP AND HSY FLANGE BLOCK BACKING PLATE DIMENSIONS

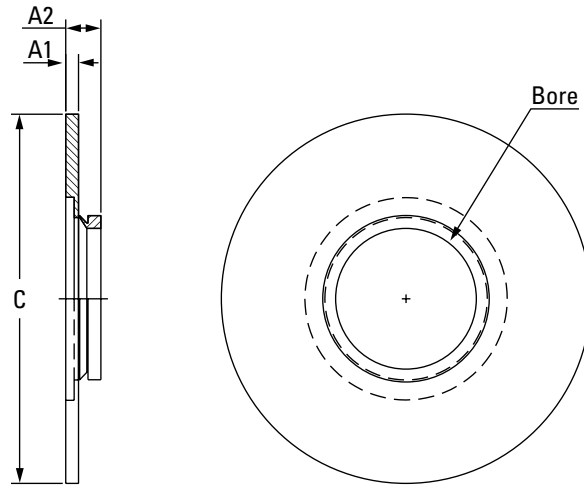

TABLE 17. UFP BACKING PLATE DIMENSIONS⁽¹⁾

Cover Part No.	Shaft Dia.	A1	A2	C
	mm in.	mm in.	mm in.	mm in.
UFP035MM	35 mm			
UFP107	1 7/16 in.	5.1	12.7	95.3
UFP108	1 1/2 in.	0.20	0.50	3.75
UFP111	1 11/16 in.			
UFP040MM	40 mm	5.1	14.0	105.9
UFP112	1 3/4 in.	0.20	0.55	4.17
UFP045MM	45 mm			
UFP115	1 15/16 in.			
UFP200	2 in.	3.8	12.7	106.4
UFP050MM	50 mm	0.15	0.50	4.19
UFP203	2 3/16 in.			
UFP204	2 1/4 in.	6.4	15.2	114.6
UFP055MM	55 mm	0.25	0.60	4.51
UFP060MM	60 mm			
UFP207	2 7/16 in.	5.1	14.0	146.1
UFP208	2 1/2 in.	0.20	0.55	5.75
UFP065MM	65 mm			
UFP211	2 11/16 in.			
UFP070MM	70 mm			
UFP212	2 3/4 in.	5.1	16.0	146.6
UFP215	2 15/16 in.	0.20	0.63	5.77
UFP300	3 in.			
UFP075MM	75 mm			
UFP303	3 3/16 in.			
UFP304	3 1/4 in.			
UFP080MM	80 mm	5.1	16.0	187.5
UFP085MM	85 mm	0.20	0.63	7.38
UFP307	3 7/16 in.			
UFP308	3 1/2 in.			
UFP090MM	90 mm			
UFP315	3 15/16 in.	5.1	16.0	206.5
UFP400	4 in.	0.20	0.63	8.13
UFP100MM	100 mm			
UFP110MM	110 mm			
UFP407	4 7/16 in.	5.1	17.8	215.9
UFP408	4 1/2 in.	0.20	0.70	8.50
UFP115MM	115 mm			
UFP125MM	125 mm			
UFP415	4 15/16 in.	5.1	17.8	299
UFP500	5 in.	0.20	0.70	11.77
UFP130MM	130 mm			

⁽¹⁾Actual backing plate may differ from drawing.

SEAL AND COVER OPTIONS • UFP AND HSY FLANGE BLOCK BACKING PLATE DIMENSIONS

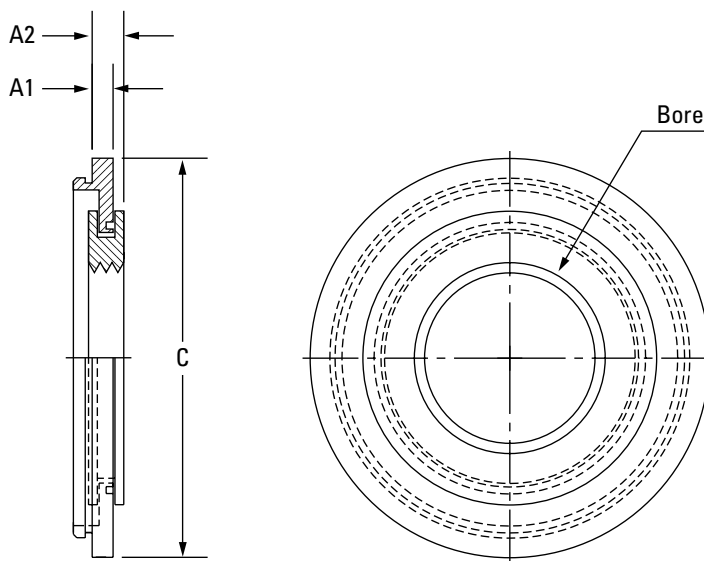

TABLE 18. HSY BACKING PLATE DIMENSIONS

Cover Part No.	Shaft Dia.	A1	A2	C
	mm in.	mm in.	mm in.	mm in.
HSY035MM	35 mm	5.1 0.20	7.6 0.30	85.9 3.38
HSY107	1 7/16 in.			
HSY108	1 1/2 in.			
HSY111	1 15/16 in.			
HSY040MM	40 mm	8.9 0.35	11.4 0.45	101.6 4.00
HSY112	1 3/4 in.			
HSY045MM	45 mm			
HSY115	1 15/16 in.	5.1 0.20	7.6 0.30	108.0 4.25
HSY200	2 in.			
HSY050MM	50 mm			
HSY203	2 3/16 in.			
HSY204	2 1/4 in.	5.1 0.20	7.6 0.30	120.1 4.73
HSY055MM	55 mm			
HSY060MM	60 mm	6.4 0.25	8.9 0.35	133.4 5.25
HSY207	2 7/16 in.			
HSY208	2 1/2 in.			
HSY065MM	65 mm			
HSY211	2 11/16 in.	6.4 0.25	8.9 0.35	155.7 6.13
HSY070MM	70 mm			
HSY212	2 3/4 in.			
UPF215	2 15/16 in.			
HSY300	3 in.	5.1 0.20	7.6 0.30	181.1 7.13
HSY075MM	75 mm			
HSY303	3 3/16 in.			
HSY304	3 1/4 in.			
HSY080MM	80 mm	5.1 0.20	7.6 0.30	199.9 7.87
HSY085MM	85 mm			
HSY307	3 7/16 in.			
HSY308	3 1/2 in.			
HSY090MM	90 mm	5.1 0.20	7.6 0.30	245.0 10.00
HSY315	3 15/16 in.			
HSY400	4 in.			
HSY100MM	100 mm			
HSY110MM	110 mm	7.6 0.30	10.2 0.40	245.0 10.00
HSY407	4 7/16 in.			
HSY408	4 1/2 in.			
HSY115MM	115 mm			

STEEL FLANGE BLOCK BACKING PLATE DIMENSIONS

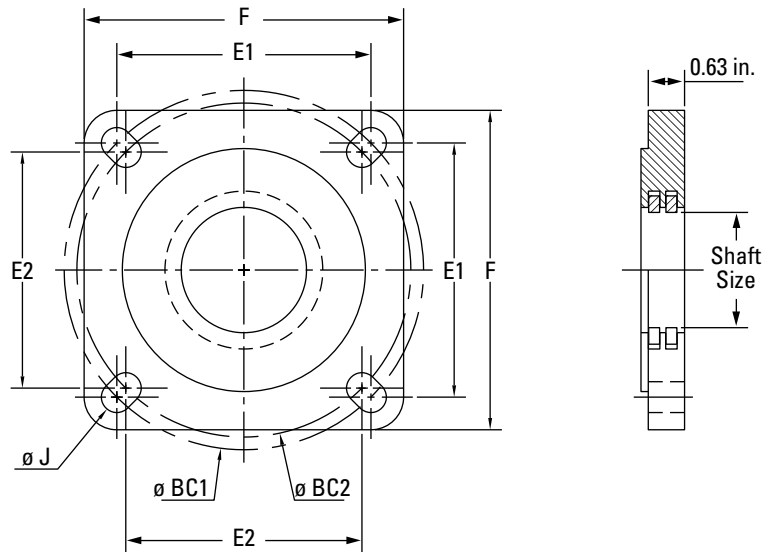

TABLE 19. STEEL BACKING PLATES AVAILABLE IN ECCENTRIC AND SET SCREW LOCKING HOUSING STYLES QMF/QAF AND QMFL/QAFL

Part Number	Shaft Dia.	F	E1	E2	BC1	BC2	J	Bolt Size	Weight
	mm in.	mm in.	mm in.	mm in.	mm in.	mm in.	mm [+1.5/-0] in. [+0.063/-0]	mm in.	kg lb.
BP10T115S	1 1/16 in.	139.7 5.50	111.1 4.38	103.3 4.07	157.1 6.19	146.1 5.75	13.5 0.53	12 1/2	2.0 4.5
BP10T200S	2 in.								
BP10T050S	50 mm								
BP11T203S	2 3/16 in.	157.2 6.19	123.8 4.88	114.5 4.51	175.1 6.89	161.9 6.38	16.7 0.66	16 5/8	2.8 6.1
BP11T204S	2 1/4 in.								
BP11T055S	55 mm								
BP13T060S	60 mm	168.4 6.63	136.5 5.38	121.2 4.77	193.1 7.60	171.5 6.75	16.7 0.66	16 5/8	3.0 6.7
BP13T207S	2 7/16 in.								
BP13T208S	2 1/2 in.								
BP13T065S	65 mm	189.0 7.44	152.4 6.00	141.4 5.57	215.5 8.49	200.0 7.88	21.0 0.83	20 3/4	3.9 8.6
BP15T211S	2 1/16 in.								
BP15T212S	2 3/4 in.								
BP15T070S	70 mm	219.2 8.63	178.0 7.01	170.6 6.72	251.7 9.91	241.3 9.50	21.0 0.83	20 3/4	5.4 12.0
BP15T215S	2 15/16 in.								
BP15T300S	3 in.								
BP15T075S	75 mm	253.2 9.97	196.9 7.75	193.1 7.60	278.4 10.96	273.1 10.75	27.0 1.06	24 7/8	7.1 15.6
BP18T303S	3 3/16 in.								
BP18T304S	3 1/4 in.								
BP18T080S	80 mm	276.4 10.88	222.3 8.75	N/A	314.3 12.38	N/A	25.0 0.98	24 7/8	8.4 18.5
BP18T085S	85 mm								
BP18T307S	3 7/16 in.								
BP18T308S	3 1/2 in.								
BP18T090S	90 mm								
BP20T311S	3 1/16 in.								
BP20T312S	3 3/4 in.								
BP20T315S	3 15/16 in.								
BP20T400S	4 in.								
BP20T100S	100 mm								
Bore Size 110mm – 115mm only available in QMF/QAF Series Housings									
BP22T110S	110 mm								
BP22T407S	4 7/16 in.								
BP22T408S	4 1/2 in.								
BP22T115S	115 mm								

STEEL BACKING PLATES WITH WITHDRAWAL HOLES

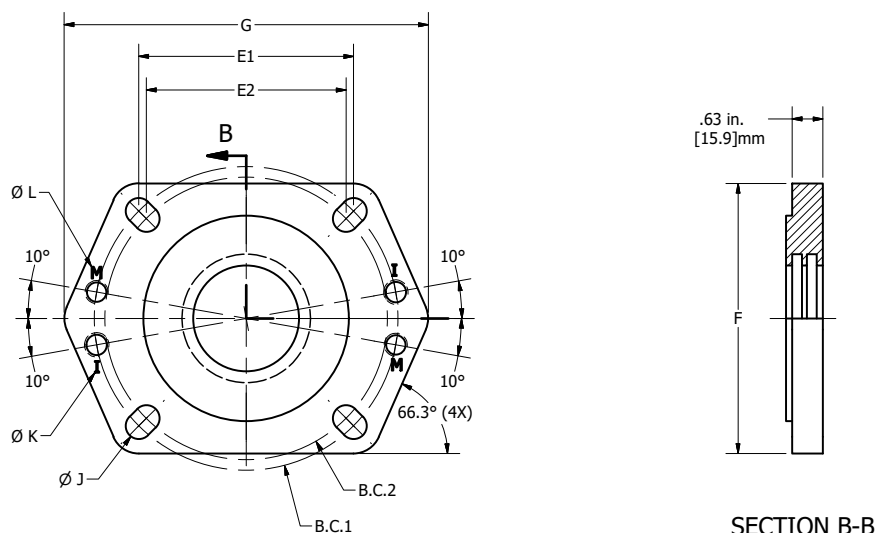

TABLE 20. STEEL BACKING PLATE WITH WITHDRAWAL HOLES

Part Number	Shaft Dia.	G	F	E1	E2	BC1	BC2	J	Bolt Size	Weight	Ø K	Ø L
	mm in.	mm in.	mm in.	mm in.	mm in.	mm in.	mm in.	mm [+1.5/-0] in. [+0.063/-0]	mm in.	kg lb.	in.	mm
BP10T115SW	1 1/16 in.	188.4 7.42	139.7 5.50	111.1 4.38	103.3 4.07	157.1 6.19	146.1 5.75	13.5 0.53	12 1/2	2.4 5.5	1/2-13 UNC -2B	M12x1.75 - 6H
BP10T200SW	2 in.											
BP10T050SW	50 mm											
BP11T203SW	2 3/16 in.	215.1 8.47	157.2 6.19	123.8 4.88	114.5 4.51	175.1 6.89	161.9 6.38	16.7 0.66	16 5/8	3.1 6.9	5/8-11 UNC -2B	M16x2 - 6H
BP11T204SW	2 1/4 in.											
BP11T055SW	55 mm											
BP13T060SW	60 mm	227.2 8.94	168.4 6.63	136.5 5.38	121.2 4.77	193.1 7.60	171.5 6.75	16.7 0.66	16 5/8	3.6 7.9	5/8-11 UNC -2B	M16x2 - 6H
BP13T207SW	2 7/16 in.											
BP13T208SW	2 1/2 in.											
BP13T065SW	65 mm	255.9 10.07	189.0 7.44	152.4 6.00	141.4 5.57	215.5 8.49	200.0 7.88	21.0 0.83	20 3/4	4.4 9.7	3/4-10 UNC -2B	M20x2.5 - 6H
BP15T211SW	2 1/16 in.											
BP15T212SW	2 3/4 in.											
BP15T070SW	70 mm	293.1 11.54	219.2 8.63	178.0 7.01	170.6 6.72	251.7 9.91	241.3 9.50	21.0 0.83	20 3/4	6.1 13.5	3/4-10 UNC -2B	M20x2.5 - 6H
BP15T215SW	2 15/16 in.											
BP15T300SW	3 in.											
BP15T075SW	75 mm	342.1 13.47	253.2 9.97	196.9 7.75	193.0 7.60	278.4 10.96	273.0 10.75	27.0 1.06	24 1	8.5 18.9	1-8 UNC -2B	M24x3 - 6H
BP18T303SW	3 3/16 in.											
BP18T304SW	3 1/4 in.											
BP18T080SW	80 mm	375.4 14.78	276.4 10.88	222.3 8.75	N/A	314.3 12.38	N/A	25.0 0.98	24 7/8	9.8 21.6	1-8 UNC -2B	M24x3 - 6H
BP18T085SW	85 mm											
BP18T307SW	3 7/16 in.											
BP18T308SW	3 1/2 in.											
BP18T090SW	90 mm											
BP20T311SW	3 1/16 in.											
BP20T312SW	3 3/4 in.											
BP20T315SW	3 15/16 in.											
BP20T400SW	4 in.											
BP20T100SW	100 mm											
BP22T110SW	110 mm											
BP22T407SW	4 7/16 in.											
BP22T408SW	4 1/2 in.											
BP22T115SW	115 mm											

BEARING LOADS

Solid-block mounted bearings are excellent for many applications including those with:

- Heavy radial loads
- Heavy combined radial and thrust loads
- Shock loads
- Harsh contamination conditions
- Low-to-moderate speeds
- The possibility of misalignment

Bearing loads generally come from one of three sources that should all be evaluated and considered when selecting steel mounted bearings for your application. Contact your Timken engineer for assistance in determining specific application loads and for bearing recommendations.

- Static loads – weights of various components supported by the bearings
- Drive loads – belts, chains or gears that exert forces on the shaft
- Imposed loads – forces generated by equipment operation

Generally, bearing loads are described as being radial (load perpendicular to the axis of the shaft) or axial (load parallel to the axis of the shaft). Axial loads also are referred to as thrust loads. Spherical roller bearings, by design, are very capable of accepting heavy radial loads, even when combined with a thrust load. Timken® Type E mounted bearings are recommended for use in applications when only thrust loads are present or when the thrust component of the load is larger than the radial component. Contact a Timken sales engineer for more information.

To determine the allowable radial load at various RPMs for bearings supporting only radial loads, simply use the charts on pages 36 – 54. For bearings supporting both radial and thrust loads, an equivalent radial load must first be calculated prior to using these tables (see DYNAMIC EQUIVALENT RADIAL LOAD on page 35).

BELT LOADS

V-belt drives are common sources of drive loads. A good approximation of drive load may be calculated from the formula:

$$\text{Drive Load} = (\text{HP} \times 189000) / (\text{Pulley Diameter} \times \text{RPM})$$

$$\text{Drive Load} = (\text{KW} \times 189000) / (\text{Pulley Diameter} \times \text{RPM})$$

LOAD SHARING

In some cases, bearings may share the load unequally, depending on their position in relationship to the load. Use the appropriate formula below to determine the drive load on each bearing:

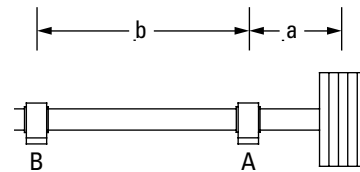

$$\text{Load A} = \text{Drive Load} \times (a + b) / b$$

$$\text{Load B} = \text{Drive Load} \times a / b$$

Fig. 30. Overhung load.

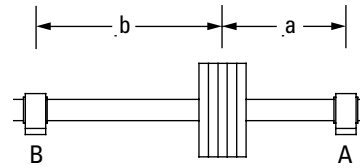

$$\text{Load A} = (\text{Drive Load} \times b) / (a + b)$$

$$\text{Load B} = (\text{Drive Load} \times a) / (a + b)$$

Fig. 31. Load between bearings.

DYNAMIC EQUIVALENT RADIAL LOAD

Bearings that support a combination of radial load and thrust load take an unequal load on one of the rows of rollers. The following formulas and bearing geometry factors are used to convert the independent thrust and radial loads into a single equivalent radial load. The calculated dynamic equivalent radial load (P_r) will have the same effect on bearing life (L_{10}) as a radial load of the same magnitude.

$$P_r = F_r + (Y_1 \times F_a) \text{ when } F_a/F_r \leq e$$

$$P_r = (0.67 \times F_r) + (Y_2 \times F_a) \text{ when } F_a/F_r > e$$

where:

P_r = Dynamic equivalent radial load

F_r = Applied radial load (lbs., N)

F_a = Applied thrust (axial) load (lbs., N)

Y_1 , Y_2 and e are bearing geometry factors shown on pages 36 – 38.

BEARING CALCULATED LIFE

Customers select the bearing life of the bearings in equipment they are building. In the absence of a customer bearing life target, the following may be considered as a guideline:

- If the customer's machinery operates eight hours a day, then use a bearing life target of 20000 to 30000 hours.
- If the customer's machinery operates 24 hours a day, then use a bearing life target of 40000 to 60000 hours.

In addition, a service factor may be used where application conditions are harsh. Extreme environmental conditions, heavy shock or vibration may require an adjustment of load ratings before referring to the L_{10} tables.

Standard spherical roller bearing life calculation:

$$\text{Bearing life} = L_{10} = (C/P_r)^{10/3} \times (16667/\text{RPM})$$

where:

C = Dynamic capacity
(lbs., N)

P_r = Radial load/dynamic equivalent radial load

RPM = Revolutions per minute

A NOTE ON MINIMUM LOADS

In order for a spherical roller bearing to perform as designed, some radial load should be present. This is particularly true if the bearing is running at high speed. Although it is rarely an issue, as the existing static loads (weights of the combined supported components) usually provide an adequate radial load, there are times when it may be necessary to use a shaft diameter larger than the actual loads require. In these instances, the load becomes a small percentage of the bearing's capacity. Radial loads less than 4 percent of C should be avoided.

BEARING RADIAL AND THRUST FACTORS

TABLE 21. V-LOCK SERIES (TAPERED BORE, C3)

Shaft Dia.	Bearing No.	Dynamic Capacity C	Static Capacity C ₀	Equivalent Radial Load Factors		
				e	Y1	Y2
mm in.		kN lbs.	kN lbs.			
50 1 15/16, 2	22211	140 31400	142 31900	0.23	2.95	4.40
55 2 3/16, 2 1/4	22212	169 38100	174 39000	0.24	2.84	4.23
55 2 3/16, 2 1/4	22213	206 46400	216 48600	0.24	2.79	4.15
60, 65 2 7/16, 2 1/2	22214	213 47800	231 52000	0.23	2.90	4.32
60, 65 2 7/16, 2 1/2	22215	222 49900	240 54100	0.22	3.14	4.67
70, 75 2 11/16, 2 3/4, 2 15/16, 3	22216	254 57200	278 62500	0.22	3.14	4.67
70, 75 2 11/16, 2 3/4, 2 15/16, 3	22217	297 66900	320 71900	0.22	3.07	4.57
80, 85, 90 3 3/16, 3 1/4, 3 7/16, 3 1/2	22219	385 86600	441 99000	0.23	2.88	4.29
80, 85, 90 3 3/16, 3 1/4, 3 7/16, 3 1/2	22220	435 97700	502 113000	0.24	2.85	4.24
100 3 11/16, 3 3/4, 3 15/16, 4	22222	555 125000	653 147000	0.25	2.73	4.06
110 —	22224	647 145000	772 174000	0.25	2.70	4.02
110, 115 4 7/16, 4 1/2	22226	757 170000	945 212000	0.26	2.62	3.90
125, 130 4 15/16, 5	22228	863 194000	1060 237000	0.25	2.67	3.98

TABLE 22. CL SERIES (STRAIGHT BORE, C NORMAL)

Shaft Dia.	Bearing No.	Dynamic Capacity C	Static Capacity C ₀	Equivalent Radial Load Factors		
				e	Y1	Y2
mm in.		kN lbs.	kN lbs.			
35 1 7/16, 1 1/2	22208	104 23400	99.7 22400	0.27	2.47	3.67
40, 45 1 11/16, 1 3/4	22209	109 24500	108 24200	0.26	2.64	3.93
50 1 15/16, 2	22210	117 26300	118 26600	0.24	2.84	4.23
55 2 3/16, 2 1/4	22211	140 31400	142 31900	0.23	2.95	4.40
60, 65 2 7/16, 2 1/2	22213	206 46400	216 48600	0.24	2.79	4.15
70, 75 2 11/16, 2 3/4, 2 15/16, 3	22215	222 49900	240 54100	0.22	3.14	4.67
80, 85, 90 3 3/16, 3 1/4, 3 7/16, 3 1/2	22218	355 79700	388 87200	0.23	2.90	4.31
100 3 15/16, 4	22220	435 97700	502 113000	0.24	2.85	4.24
110, 115 4 7/16, 4 1/2	22222	555 125000	653 147000	0.25	2.73	4.06
125, 130 4 15/16, 5	22226	757 170000	945 212000	0.26	2.62	3.90

TABLE 23. EC SERIES (STRAIGHT BORE, C NORMAL)

Shaft Dia.	Bearing No.	Dynamic Capacity C	Static Capacity C ₀	Equivalent Radial Load Factors		
				e	Y1	Y2
mm in.		kN lbs.	kN lbs.			
35 1 ⁷ / ₁₆ , 1 ¹ / ₂	22208	104 23400	99.7 22400	0.27	2.47	3.67
40, 45 1 ¹¹ / ₁₆ , 1 ³ / ₄	22209	109 24500	108 24200	0.26	2.64	3.93
50 1 ¹⁵ / ₁₆ , 2	22210	117 26300	118 26600	0.24	2.84	4.23
55 2 ³ / ₁₆ , 2 ¹ / ₄	22211	140 31400	142 31900	0.23	2.95	4.40
60, 65 2 ⁷ / ₁₆ , 2 ¹ / ₂	22213	206 46400	216 48600	0.24	2.79	4.15
70, 75 2 ¹¹ / ₁₆ , 2 ³ / ₄ , 2 ¹⁵ / ₁₆ , 3	22215	222 49900	240 54100	0.22	3.14	4.67
80, 85, 90 3 ³ / ₁₆ , 3 ¹ / ₄ , 3 ⁷ / ₁₆ , 3 ¹ / ₂	22218	355 79700	388 87200	0.23	2.90	4.31
100 3 ¹¹ / ₁₆ , 3 ³ / ₄ , 3 ¹⁵ / ₁₆ , 4	22220	435 97700	502 113000	0.24	2.85	4.24
110, 115 4 ⁷ / ₁₆ , 4 ¹ / ₂	22222	555 125000	653 147000	0.25	2.73	4.06
125, 130 4 ¹⁵ / ₁₆ , 5	22226	757 170000	945 212000	0.26	2.62	3.90
140, 150 5 ⁷ / ₁₆ , 5 ¹ / ₂ , 5 ¹⁵ / ₁₆ , 6	23230	1270 286000	1660 372000	0.32	2.08	3.10
170, 180 6 ⁷ / ₁₆ , 6 ¹ / ₂ , 6 ¹⁵ / ₁₆ , 7	23234	1660 373000	2200 494000	0.33	2.08	3.09

BEARING RADIAL AND THRUST FACTORS – continued

TABLE 24. TA/TAA DV/DAA SERIES (TAPERED BORE, C3)

Shaft Dia.	Bearing No.	Dynamic Capacity C	Static Capacity C ₀	Equivalent Radial Load Factors		
				e	Y1	Y2
mm in.		kN lbs.	kN lbs.			
40 1 7/16, 1 1/2	22209	109 24500	108 24200	0.26	2.64	3.93
45 1 11/16, 1 3/4	22210	117 26300	118 26600	0.24	2.84	4.23
50 1 15/16, 2	22211	140 31400	142 31900	0.23	2.95	4.40
55 —	22212	169 38100	174 39000	0.24	2.84	4.23
60 2 3/16, 2 3/16	22213	206 46400	216 48600	0.24	2.79	4.15
65 2 7/16, 2 1/2	22215	222 49900	240 54100	0.22	3.14	4.67
70 2 11/16, 2 3/4	22216	254 57200	278 62500	0.22	3.14	4.67
75 2 15/16, 3	22217	297 66900	320 71900	0.22	3.07	4.57
80 3 3/16, 3 3/16	22218	355 79700	388 87200	0.23	2.90	4.31
85 —	22219	385 86600	441 99000	0.23	2.88	4.29
90 3 7/16, 3 1/2	22220	435 97700	502 113000	0.24	2.85	4.24
100 3 11/16, 3 3/4, 3 15/16, 4	22222	555 125000	653 147000	0.25	2.73	4.06
110 4 3/16, 4 1/4	22224	647 145000	772 174000	0.25	2.70	4.02
115 4 7/16, 4 1/2	22226	757 170000	945 212000	0.26	2.62	3.90
125 4 15/16, 5	22228	863 194000	1060 237000	0.25	2.67	3.98
135 5 3/16, 5 1/4	23130	1000 225000	1390 312000	0.29	2.34	3.45
140 5 3/8, 5 7/16, 5 1/2	23132	1160 261000	1580 355000	0.29	2.33	3.46
150 5 13/16, 5 7/8, 5 15/16, 6	23134	1220 274000	1710 384000	0.28	2.39	3.55
160 6 5/16, 6 3/8, 6 7/16, 6 1/2	23136	1410 317000	2000 450000	0.29	2.32	3.45
170 6 13/16, 6 7/8, 6 15/16, 7	23138	1630 366000	2340 526000	0.30	2.26	3.36
180 7 1/8, 7 3/16, 7 1/4	23140	1660 373000	2290 515000	0.31	2.15	3.20
200 7 13/16, 7 7/8, 7 15/16, 8	23144	1940 436000	2740 616000	0.31	2.17	3.24
220 8 7/16, 8 1/2, 8 15/16, 9	23148	2200 495000	3180 715000	0.30	2.28	3.40
240 9 7/16, 9 1/2	23152	2440 549000	3910 879000	0.30	2.23	3.31
260 9 15/16, 10, 10 7/16, 10 1/2	23156	2530 569000	4140 931000	0.30	2.26	3.36
280 10 15/16, 11	23160	3070 690000	5110 1149000	0.30	2.25	3.35
300 11 7/16, 11 1/2, 11 15/16, 12	23164	3650 821000	5930 1333000	0.31	2.14	3.19
320 12 7/16, 12 1/2	23168	4110 924000	6830 1535000	0.30	2.22	3.30
340 12 15/16, 13, 13 7/16, 13 1/2	23172	4250 955000	7280 1637000	0.29	2.29	3.42
360 13 15/16, 14	23176	4490 1009000	7580 1704000	0.30	2.28	3.39
380 14 15/16, 15	23180	4770 1072000	8110 1823000	0.29	2.32	3.46

LOAD RATINGS

TABLE 25. V-LOCK SERIES – ALLOWABLE RADIAL LOAD (kN/LBS.) AT VARIOUS RPM⁽¹⁾

Shaft Diameter	Bearing No.	C	L ₁₀ Life	Speed ⁽²⁾													
				RPM													
mm in.		kN lbs.		50	100	200	500	1000	1200	1500	1800	2100	2400	2700	3000	3200	3500 ⁽¹⁾
50 1 15/16, 2	22211	140 31400	10000	50.3 11319	40.9 9194	33.2 7468	25.2 5673	20.5 4608	19.4 4362	18.1 4080	17.2 3863	16.4 3688	15.8 3543	15.2 3420	14.7 3314	14.5 3250	14.1 3164
			30000	36.2 8141	29.4 6612	23.9 5371	18.1 4080	14.7 3314	14.0 3138	13.1 2934	12.4 2778	11.8 2653	11.3 2549	10.9 2460	10.6 2383	10.4 2338	10.4 2276
			40000	33.2 7468	27.0 6066	21.9 4927	16.6 3743	13.5 3040	12.8 2878	12.0 2692	11.3 2549	10.8 2433	10.4 2338	10.0 2257	9.7 2186	9.5 2144	9.5 2088
			60000	29.4 6612	23.9 5371	19.4 4362	14.7 3314	12.0 2692	11.3 2549	10.6 2383	10.0 2257	9.6 2155	9.2 2070	8.9 1998	8.6 1936	8.4 1899	8.4 1849
			100000	25.2 5673	20.5 4608	16.6 3743	12.6 2843	10.3 2309	9.7 2186	9.1 2045	8.6 1936	8.2 1849	7.9 1776	7.6 1714	7.4 1661	7.4 1629	7.2 1586
55 2 3/16, 2 1/4	22212	169 38100	10000	61.1 13734	49.6 11155	40.3 9061	30.6 6883	24.9 5591	23.5 5293	22.0 4951	20.8 4687	19.9 4475	19.1 4300	18.5 4150	17.9 4021	17.5 3944	17.1 3839
			30000	43.9 9878	35.7 8023	29.0 6517	22.0 4951	17.9 4021	16.9 3807	15.8 3561	15.0 3371	14.3 3219	13.8 3092	13.3 2985	12.9 2892	12.6 2837	12.3 2761
			40000	40.3 9061	32.7 7360	26.6 5978	20.2 4541	16.4 3689	15.5 3492	14.5 3266	13.8 3092	13.1 2953	12.6 2837	12.2 2738	11.8 2653	11.6 2602	11.3 2533
			60000	35.7 8023	29.0 6517	23.5 5293	17.9 4021	14.5 3266	13.8 3092	12.9 2892	12.2 2738	11.6 2614	11.2 2512	10.8 2425	10.4 2349	10.2 2304	10.0 2243
			100000	30.6 6883	24.9 5591	20.2 4541	15.3 3450	12.5 2802	11.8 2653	11.0 2481	10.4 2349	10.0 2243	9.6 2155	9.3 2080	9.0 2015	8.8 1977	8.6 1924
55 2 3/16, 2 1/4	22213	206 46400	10000	74.4 16726	60.4 13585	49.1 11035	37.3 8383	30.3 6809	28.7 6446	26.8 6029	25.4 5708	24.2 5450	23.3 5236	22.5 5054	21.8 4897	21.4 4803	20.8 4676
			30000	53.5 12030	43.5 9771	35.3 7937	26.8 6029	21.8 4897	20.6 4636	19.3 4336	18.3 4105	17.4 3920	16.8 3766	16.2 3635	15.7 3522	15.4 3455	15.0 3363
			40000	49.1 11035	39.9 8963	32.4 7280	24.6 5531	20.0 4492	18.9 4253	17.7 3978	16.8 3766	16.0 3596	15.4 3455	14.8 3335	14.4 3231	14.1 3169	13.7 3085
			60000	43.5 9771	35.3 7937	28.7 6446	21.8 4897	17.7 3978	16.8 3766	15.7 3522	14.8 3335	14.2 3184	13.6 3059	13.1 2953	12.7 2861	12.5 2806	12.2 2732
			100000	37.3 8383	30.3 6809	24.6 5531	18.7 4201	15.2 3413	14.4 3231	13.4 3022	12.7 2861	12.2 2732	11.7 2624	11.3 2533	10.9 2454	10.7 2407	10.4 2343
60, 65 2 7/16, 2 1/2	22214	213 47800	10000	76.6 17230	62.3 13995	50.6 11368	38.4 8636	31.2 7014	29.5 6641	27.6 6211	26.2 5880	25.0 5615	24.0 5394	23.2 5207	22.4 5045	22.0 4948	
			30000	55.1 12392	44.8 10066	36.4 8176	27.6 6211	22.4 5045	21.2 4776	19.9 4467	18.8 4229	18.0 4038	17.3 3880	16.7 3745	16.1 3628	15.8 3559	
			40000	50.6 11368	41.1 9234	33.4 7500	25.3 5697	20.6 4628	19.5 4381	18.2 4098	17.3 3880	16.5 3704	15.8 3559	15.3 3435	14.8 3328	14.5 3265	
			60000	44.8 10066	36.4 8176	29.5 6641	22.4 5045	18.2 4098	17.3 3880	16.1 3628	15.3 3435	14.6 3280	14.0 3151	13.5 3042	13.1 2947	12.9 2891	
			100000	38.4 8636	31.2 7014	25.3 5697	19.3 4328	15.6 3515	14.8 3328	13.8 3113	13.1 2947	12.5 2814	12.0 2703	11.6 2610	11.2 2528	11.0 2480	
				50	100	200	500	1000	1200	1500	1800	2100	2400	2700 ⁽¹⁾	3000 ⁽¹⁾	3200 ⁽¹⁾	

⁽¹⁾Speeds referenced here may be higher than speed rating for seals. Please refer to the charts on pages 57 – 59.

⁽²⁾For speeds greater than thermal reference speed, contact your Timken engineer.

Continued on next page.

LOAD RATINGS – continued

TABLE 25. V-LOCK SERIES – ALLOWABLE RADIAL LOAD (kN/LBS.) AT VARIOUS RPM⁽¹⁾ (CONTINUED)

Shaft Diameter	Bearing No.	C	L ₁₀ Life	Speed ⁽²⁾																
				RPM																
mm in.		kN lbs.		10000	15000	20000	25000	30000	35000	40000	45000	50000	55000	60000	65000	70000	75000	80000		
60, 65 2 1/16, 2 1/2	22215	222 49900	10000	80.0 17987	65.0 14610	52.8 11867	40.1 9015	32.6 7322	30.8 6933	28.8 6484	27.3 6139	26.1 5861	25.0 5631	24.2 5436	23.4 5266	23.0 5166				
			30000	57.5 12937	46.7 10508	38.0 8535	28.8 6484	23.4 5266	22.2 4986	20.7 4663	19.6 4415	18.8 4216	18.0 4050	17.4 3909	16.8 3788	16.5 3715				
			40000	52.8 11867	42.9 9639	34.8 7829	26.5 5948	21.5 4831	20.3 4574	19.0 4278	18.0 4050	17.2 3867	16.5 3715	16.0 3586	15.5 3475	15.2 3408				
			60000	46.7 10508	38.0 8535	30.8 6933	23.4 5266	19.0 4278	18.0 4050	16.8 3788	16.0 3586	15.2 3424	14.6 3290	14.1 3175	13.7 3077	13.4 3018				
			100000	40.1 9015	32.6 7322	26.5 5948	20.1 4518	16.3 3670	15.5 3475	14.5 3250	13.7 3077	13.1 2938	12.6 2822	12.1 2724	11.7 2639	11.5 2589				
							50	100	200	500	1000	1200	1500	1800	2100	2400 ⁽¹⁾	2700 ⁽¹⁾	3000 ⁽¹⁾		
70, 75 2 1/16, 2 3/4, 2 15/16, 3	22216	254 57200	10000	91.7 20619	74.5 16748	60.5 13603	46.0 10334	37.3 8394	35.4 7947	33.1 7432	31.3 7037	29.9 6719	28.7 6455	27.7 6231	26.9 6037					
			30000	66.0 14829	53.6 12045	43.5 9784	33.1 7432	26.9 6037	25.4 5716	23.8 5346	22.5 5061	21.5 4832	20.7 4643	19.9 4481	19.3 4342					
			40000	60.5 13603	49.1 11049	39.9 8975	30.3 6818	24.6 5538	23.3 5243	21.8 4904	20.7 4643	19.7 4433	18.9 4259	18.3 4111	17.7 3983	17.7 3983				
			60000	53.6 12045	43.5 9784	35.4 7947	26.9 6037	21.8 4904	20.7 4643	19.3 4342	18.3 4111	17.5 3925	16.8 3771	16.2 3640	15.7 3527	15.7 3527				
			100000	46.0 10334	37.3 8394	30.3 6818	23.0 5179	18.7 4207	17.7 3983	16.6 3725	15.7 3527	15.0 3367	14.4 3235	13.9 3123	13.5 3026	13.5 3026				
							50	100	200	500	1000	1200	1500	1800	2100 ⁽¹⁾	2400 ⁽¹⁾	2700 ⁽¹⁾			
70, 75 2 1/16, 2 3/4, 2 15/16, 3	22217	297 66900	10000	107.3 24115	87.1 19588	70.8 15910	53.8 12086	43.7 9817	41.3 9295	38.7 8693	36.6 8230	35.0 7858	33.6 7550	32.4 7287						
			30000	77.1 17344	62.7 14088	50.9 11443	38.7 8693	31.4 7061	29.7 6685	27.8 6252	26.3 5919	25.1 5652	24.2 5430	23.3 5241	23.3 5241					
			40000	70.8 15910	57.5 12923	46.7 10497	35.5 7974	28.8 6477	27.3 6132	25.5 5735	24.2 5430	23.1 5184	22.2 4981	21.4 4808	21.4 4808	21.4 4808				
			60000	62.7 14088	50.9 11443	41.3 9295	31.4 7061	25.5 5735	24.2 5430	22.6 5078	21.4 4808	20.4 4591	20.4 4410	19.6 4257	19.6 4257	19.6 4257				
			100000	53.8 12086	43.7 9817	35.5 7974	26.9 6057	21.9 4920	20.7 4658	19.4 4357	18.3 4125	17.5 3938	16.8 3784	16.2 3652	16.2 3652	16.2 3652				
							50	100	200	500	1000	1200	1500	1800	2100 ⁽¹⁾	2400 ⁽¹⁾	2700 ⁽¹⁾			
80, 85, 90 3 3/16, 3 1/4, 3 7/16, 3 1/2	22219	385 86600	10000	138.9 31216	112.8 25356	91.6 20595	69.6 15645	56.5 12708	53.5 12032	50.1 11252	47.4 10654	45.2 10172	43.5 9773	42.0 9433						
			30000	99.9 22452	81.1 18236	65.9 14813	50.1 11252	40.7 9140	38.5 8653	36.0 8093	34.1 7662	32.5 7316	31.3 7029	30.2 6785	30.2 6785					
			40000	91.6 20595	74.4 16729	60.4 13588	45.9 10322	37.3 8384	35.3 7938	33.0 7424	31.3 7029	29.9 6711	28.7 6448	27.7 6224	27.7 6224	27.7 6224				
			60000	81.1 18236	65.9 14813	53.5 12032	40.7 9140	33.0 7424	31.3 7029	29.2 6574	27.7 6224	26.4 5942	25.4 5709	24.5 5511	24.5 5511	24.5 5511				
			100000	69.6 15645	56.5 12708	45.9 10322	34.9 7841	28.3 6369	26.8 6030	25.1 5640	23.7 5339	22.7 5098	21.8 4898	21.0 4728	21.0 4728	21.0 4728				
							50	100	200	500	1000	1200	1500	1800	2100 ⁽¹⁾	2400 ⁽¹⁾	2700 ⁽¹⁾			

⁽¹⁾Speeds referenced here may be higher than speed rating for seals. Please refer to the charts on pages 57 – 59.
⁽²⁾For speeds greater than thermal reference speed, contact your Timken engineer.

Continued on next page.

Continued from previous page.

Shaft Diameter	Bearing No.	C	L ₁₀ Life	Speed ⁽²⁾										
				RPM										
mm in.		kN lbs.		50	100	200	500	1000	1200	1500	1800 ⁽¹⁾	2100 ⁽¹⁾	2400 ⁽¹⁾	2700 ⁽¹⁾
80, 85, 90 3 3/16, 3 1/4, 3 1/2, 3 1/2	22220	435 97700	10000	156.7 35218	127.2 28606	103.4 23235	78.5 17651	63.8 14337	60.4 13574	56.5 12695	53.5 12019	51.0 11476	49.0 11025	47.3 10642
			30000	112.7 25329	91.5 20574	74.3 16711	56.5 12695	45.9 10311	43.4 9762	40.6 9130	38.5 8644	36.7 8254	35.3 7930	34.0 7654
			40000	103.4 23235	84.0 18873	68.2 15329	51.8 11645	42.1 9459	39.8 8955	37.3 8375	35.3 7930	33.7 7571	32.4 7274	31.2 7021
			60000	91.5 20574	74.3 16711	60.4 13574	45.9 10311	37.3 8375	35.3 7930	33.0 7416	31.2 7021	29.8 6704	28.7 6441	27.7 6217
			100000	78.5 17651	63.8 14337	51.8 11645	39.3 8846	32.0 7185	30.3 6803	28.3 6362	26.8 6024	25.6 5752	24.6 5526	23.7 5334
100 3 11/16, 3 3/4, 3 15/16, 4	22222	555 125000	10000	200.4 45058	162.8 36599	132.2 29727	100.5 22583	81.6 18343	77.3 17367	72.2 16242	68.4 15377	65.3 14683	62.7 14106	
			30000	144.2 32407	117.1 26323	95.1 21381	72.2 16242	58.7 13193	55.6 12490	52.0 11682	49.2 11060	47.0 10560	45.1 10145	
			40000	132.2 29727	107.4 24146	87.2 19613	66.3 14899	53.8 12102	51.0 11458	47.7 10716	45.1 10145	43.1 9687	41.4 9306	
			60000	117.1 26323	95.1 21381	77.3 17367	58.7 13193	47.7 10716	45.1 10145	42.2 9488	40.0 8983	38.2 8577	36.7 8241	
			100000	100.5 22583	81.6 18343	66.3 14899	50.3 11318	40.9 9193	38.7 8704	36.2 8140	34.3 7707	32.7 7359	31.4 7070	
110 —	22224	647 145000	10000	232.5 52268	188.8 42455	153.4 34484	116.5 26196	94.6 21278	89.6 20145	83.8 18841	79.3 17838	75.8 17032	72.8 16363	
			30000	167.2 37592	135.8 30534	110.3 24802	83.8 18841	68.1 15303	64.5 14489	60.3 13551	57.1 12829	54.5 12250	52.4 11769	
			40000	153.4 34484	124.6 28010	101.2 22751	76.9 17283	62.4 14038	59.1 13291	55.3 12430	52.4 11769	50.0 11237	48.0 10796	
			60000	135.8 30534	110.3 24802	89.6 20145	68.1 15303	55.3 12430	52.4 11769	49.0 11007	46.4 10421	44.3 9950	42.5 9559	
			100000	116.5 26196	94.6 21278	76.9 17283	58.4 13129	47.4 10664	44.9 10097	42.0 9443	39.8 8940	38.0 8536	36.5 8201	

⁽¹⁾Speeds referenced here may be higher than speed rating for seals. Please refer to the charts on pages 57 – 59.

⁽²⁾For speeds greater than thermal reference speed, contact your Timken engineer.

Continued on next page.

LOAD RATINGS – continued

TABLE 25. V-LOCK SERIES – ALLOWABLE RADIAL LOAD (kN/LBS.) AT VARIOUS RPM⁽¹⁾ (CONTINUED)

Shaft Diameter	Bearing No.	C	L ₁₀ Life	Speed ⁽²⁾								
				RPM								
mm in.		kN lbs.		50	100	200	500	1000	1200 ⁽¹⁾	1500 ⁽¹⁾	1800 ⁽¹⁾	2100 ⁽¹⁾
110, 115 4 7/16, 4 1/2	22226	757 170000	10000	272.6	221.4	179.8	136.6	111.0	105.1	98.3	93.0	88.8
				61279	49774	40429	30712	24946	23618	22089	20913	19968
			30000	196.1	159.2	129.3	98.3	79.8	75.6	70.7	66.9	63.9
				44074	35799	29078	22089	17942	16987	15887	15041	14362
			40000	179.8	146.1	118.6	90.1	73.2	69.3	64.8	61.4	58.6
				40429	32839	26673	20263	16458	15582	14573	13798	13174
			60000	159.2	129.3	105.1	79.8	64.8	61.4	57.4	54.3	51.9
				35799	29078	23618	17942	14573	13798	12904	12217	11665
			100000	136.6	111.0	90.1	68.5	55.6	52.7	49.2	46.6	44.5
				30712	24946	20263	15393	12503	11837	11071	10482	10008
				50	100	200	500	1000 ⁽¹⁾	1200 ⁽¹⁾	1500 ⁽¹⁾	1800 ⁽¹⁾	
125, 130 4 15/16, 5	22228	863 194000	10000	311.1	252.7	205.2	155.9	126.6	119.9	112.1	106.2	
				69931	56801	46137	35048	28468	26953	25208	23866	
			30000	223.7	181.7	147.6	112.1	91.1	86.2	80.6	76.4	
				50296	40853	33183	25208	20475	19385	18130	17165	
			40000	205.2	166.7	135.4	102.9	83.5	79.1	74.0	70.0	
				46137	37475	30439	23123	18782	17782	16631	15746	
60000	181.7	147.6	119.9	91.1	74.0	70.0	65.5	62.0				
	40853	33183	26953	20475	16631	15746	14726	13942				
100000	155.9	126.6	102.9	78.1	63.5	60.1	56.2	53.2				
	35048	28468	23123	17566	14268	13508	12634	11961				

⁽¹⁾Speeds referenced here may be higher than speed rating for seals. Please refer to the charts on pages 57 – 59.

⁽²⁾For speeds greater than thermal reference speed, contact your Timken engineer.

TABLE 26. CL SERIES – ALLOWABLE RADIAL LOAD (kN/LBS.) AT VARIOUS RPM⁽¹⁾

Shaft Diameter	Bearing No.	C	L ₁₀ Life	Speed ⁽²⁾														
				RPM														
mm in.		kN lbs.		50	100	200	500	1000	1200	1500	1800	2100	2400	2700	3000	3200	3500	
35 1 1/16, 1 1/2	22208	104 23400	10000	37.5	30.5	24.8	18.8	15.3	14.5	13.5	12.8	12.2	11.7	11.3	11.0	10.8	10.5	
				8435	6851	5565	4227	3434	3251	3041	2879	2749	2641	2549	2470	2422	2358	
				30000	27.0	21.9	17.8	13.5	11.0	10.4	9.7	9.2	8.8	8.4	8.2	7.9	7.7	7.5
				6067	4928	4002	3041	2470	2338	2187	2070	1977	1899	1833	1776	1742	1696	
				40000	24.8	20.1	16.3	12.4	10.1	9.5	8.9	8.4	8.1	7.7	7.5	7.2	7.1	6.9
				5565	4520	3672	2789	2265	2145	2006	1899	1813	1742	1682	1629	1598	1556	
40, 45 1 1/16, 1 3/4	22209	109 24500	10000	39.3	31.9	25.9	19.7	16.0	15.1	14.2	13.4	12.8	12.3	11.9	11.5	11.3	11.0	
				8831	7173	5827	4426	3595	3404	3183	3014	2878	2765	2669	2586	2536	2469	
				30000	28.3	22.9	18.6	14.2	11.5	10.9	10.2	9.6	9.2	8.8	8.5	8.3	8.1	7.9
				6352	5159	4191	3183	2586	2448	2290	2168	2070	1988	1919	1860	1824	1776	
				40000	25.9	21.1	17.1	13.0	10.6	10.0	9.3	8.8	8.4	8.1	7.8	7.6	7.4	7.2
				5827	4733	3844	2920	2372	2246	2100	1988	1899	1824	1761	1706	1673	1629	
50 1 5/16, 2	22210	117 26300	10000	42.2	34.3	27.8	21.1	17.2	16.3	15.2	14.4	13.7	13.2	12.7	12.3	12.1	11.8	
				9480	7700	6255	4751	3859	3654	3417	3235	3089	2968	2865	2776	2723	2650	
				30000	30.3	24.6	20.0	15.2	12.3	11.7	10.9	10.4	9.9	9.5	9.2	8.9	8.7	8.5
				6818	5538	4498	3417	2776	2628	2458	2327	2222	2135	2060	1996	1958	1906	
				40000	27.8	22.6	18.4	13.9	11.3	10.7	10.0	9.5	9.1	8.7	8.4	8.1	8.0	7.8
				6255	5080	4127	3135	2546	2411	2255	2135	2038	1958	1890	1831	1796	1749	
55 2 3/16, 2 1/2	22211	140 31400	10000	50.3	40.9	33.2	25.2	20.5	19.4	18.1	17.2	16.4	15.8	15.2	14.7	14.5	14.1	
				11319	9194	7468	5673	4608	4362	4080	3863	3688	3543	3420	3314	3250	3164	
				30000	36.2	29.4	23.9	18.1	14.7	14.0	13.1	12.4	11.8	11.3	10.9	10.6	10.4	10.1
				8141	6612	5371	4080	3314	3138	2934	2778	2653	2549	2460	2383	2338	2276	
				40000	33.2	27.0	21.9	16.6	13.5	12.8	12.0	11.3	10.8	10.4	10.0	9.7	9.5	9.3
				7468	6066	4927	3743	3040	2878	2692	2549	2433	2338	2257	2186	2144	2088	
60, 65 2 7/16, 2 1/2	22213	206 46400	10000	29.4	23.9	19.4	14.7	12.0	11.3	10.6	10.0	9.6	9.2	8.9	8.6	8.4	8.2	
				6612	5371	4362	3314	2692	2549	2383	2257	2155	2070	1998	1936	1899	1849	
				30000	25.2	20.5	16.6	12.6	10.3	9.7	9.1	8.6	8.2	7.9	7.6	7.4	7.2	7.1
				5673	4608	3743	2843	2309	2186	2045	1936	1849	1776	1714	1661	1629	1586	
				40000	21.1	17.2	13.9	10.6	8.6	8.1	7.6	7.2	6.9	6.6	6.4	6.2	6.1	5.9
				4751	3859	3135	2381	1934	1831	1713	1622	1548	1487	1436	1391	1364	1328	
60, 65 2 7/16, 2 1/2	22213	206 46400	10000	50	100	200	500	1000	1200	1500	1800	2100	2400	2700	3000 ⁽¹⁾	3200 ⁽¹⁾	3500 ⁽¹⁾	
				10000	74.4	60.4	49.1	37.3	30.3	28.7	26.8	25.4	24.2	23.3	22.5	21.8	21.4	20.8
				16726	13585	11035	8383	6809	6446	6029	5708	5450	5236	5054	4897	4803	4676	
				30000	53.5	43.5	35.3	26.8	21.8	20.6	19.3	18.3	17.4	16.8	16.2	15.7	15.4	15.0
				12030	9771	7937	6029	4897	4636	4336	4105	3920	3766	3635	3522	3455	3363	
				40000	49.1	39.9	32.4	24.6	20.0	18.9	17.7	16.8	16.0	15.4	14.8	14.4	14.1	13.7
11035	8963	7280	5531	4492	4253	3978	3766	3596	3455	3335	3231	3169	3085					
60, 65 2 7/16, 2 1/2	22213	206 46400	60000	43.5	35.3	28.7	21.8	17.7	16.8	15.7	14.8	14.2	13.6	13.1	12.7	12.5	12.2	
				9771	7937	6446	4897	3978	3766	3522	3335	3184	3059	2953	2861	2806	2732	
				100000	37.3	30.3	24.6	18.7	15.2	14.4	13.4	12.7	12.2	11.7	11.3	10.9	10.7	10.4
				8383	6809	5531	4201	3413	3231	3022	2861	2732	2624	2533	2454	2407	2343	

⁽¹⁾Speeds referenced here may be higher than speed rating for seals. Please refer to the charts on pages 57 – 59.

Continued on next page.

⁽²⁾For speeds greater than thermal reference speed, contact your Timken engineer.

LOAD RATINGS – continued

TABLE 26. CL SERIES – ALLOWABLE RADIAL LOAD (kN/LBS.) AT VARIOUS RPM⁽¹⁾ (CONTINUED)

Shaft Diameter	Bearing No.	C	L ₁₀ Life	Speed ⁽²⁾												
				RPM												
mm in.		kN lbs.		50	100	200	500	1000	1200	1500	1800	2100	2400	2700 ⁽¹⁾	3000 ⁽¹⁾	3200 ⁽¹⁾
70, 75 2 1/16, 2 3/4, 2 15/16, 3	22215	220 49900	10000	80.0 17987	65.0 14610	52.8 11867	40.1 9015	32.6 7322	30.8 6933	28.8 6484	27.3 6139	26.1 5861	25.0 5631	24.2 5436	23.4 5266	23.0 5166
			30000	57.5 12937	46.7 10508	38.0 8535	28.8 6484	23.4 5266	22.2 4986	20.7 4663	19.6 4415	18.8 4216	18.0 4050	17.4 3909	16.8 3788	16.5 3715
			40000	52.8 11867	42.9 9639	34.8 7829	26.5 5948	21.5 4831	20.3 4574	19.0 4278	18.0 4050	17.2 3867	16.5 3715	16.0 3586	15.5 3475	15.2 3408
			60000	46.7 10508	38.0 8535	30.8 6933	23.4 5266	19.0 4278	18.0 4050	16.8 3788	16.0 3586	15.2 3424	14.6 3290	14.1 3175	13.7 3077	13.4 3018
			100000	40.1 9015	32.6 7322	26.5 5948	20.1 4518	16.3 3670	15.5 3475	14.5 3250	13.7 3077	13.1 2938	12.6 2822	12.1 2724	11.7 2639	11.5 2589
							50	100	200	500	1000	1200	1500	1800	2100 ⁽¹⁾	2400 ⁽¹⁾
80, 85, 90 3 3/16, 3 1/4, 3 7/16, 3 1/2	22218	355 79700	10000	127.8 28729	103.8 23335	84.3 18954	64.0 14399	52.0 11695	49.3 11073	46.1 10356	43.6 9805	41.6 9362	40.0 8994	38.6 8682		
			30000	91.9 20663	74.7 16783	60.6 13632	46.1 10356	37.4 8412	35.4 7964	33.1 7448	31.4 7052	29.9 6733	28.8 6469	27.8 6244		
			40000	84.3 18954	68.5 15396	55.6 12505	42.3 9500	34.3 7716	32.5 7305	30.4 6832	28.8 6469	27.5 6176	26.4 5934	25.5 5728		
			60000	74.7 16783	60.6 13632	49.3 11073	37.4 8412	30.4 6832	28.8 6469	26.9 6050	25.5 5728	24.3 5469	23.4 5254	22.6 5072		
			100000	64.0 14399	52.0 11695	42.3 9500	32.1 7216	26.1 5862	24.7 5550	23.1 5190	21.9 4914	20.9 4692	20.1 4508	19.4 4351		
							50	100	200	500	1000	1200	1500	1800 ⁽¹⁾	2100 ⁽¹⁾	2400 ⁽¹⁾
100 3 15/16, 4	22220	435 97700	10000	156.7 35218	127.2 28606	103.4 23235	78.5 17651	63.8 14337	60.4 13574	56.5 12695	53.5 12019	51.0 11476	49.0 11025	47.3 10642		
			30000	112.7 25329	91.5 20574	74.3 16711	56.5 12695	45.9 10311	43.4 9762	40.6 9130	38.5 8644	36.7 8254	35.3 7930	34.0 7654		
			40000	103.4 23235	84.0 18873	68.2 15329	51.8 11645	42.1 9459	39.8 8955	37.3 8375	35.3 7930	33.7 7571	32.4 7274	31.2 7021		
			60000	91.5 20574	74.3 16711	60.4 13574	45.9 10311	37.3 8375	35.3 7930	33.0 7416	31.2 7021	29.8 6704	28.7 6441	27.7 6217		
			100000	78.5 17651	63.8 14337	51.8 11645	39.3 8846	32.0 7185	30.3 6803	28.3 6362	26.8 6024	25.6 5752	24.6 5526	23.7 5334		
							50	100	200	500	1000	1200	1500 ⁽¹⁾	1800 ⁽¹⁾	2100 ⁽¹⁾	2400 ⁽¹⁾
110, 115 4 7/16, 4 1/2	22222	555 125000	10000	200.4 45058	162.8 36599	132.2 29727	100.5 22583	81.6 18343	77.3 17367	72.2 16242	68.4 15377	65.3 14683	62.7 14106			
			30000	144.2 32407	117.1 26323	95.1 21381	72.2 16242	58.7 13193	55.6 12490	52.0 11682	49.2 11060	47.0 10560	45.1 10145			
			40000	132.2 29727	107.4 24146	87.2 19613	66.3 14899	53.8 12102	51.0 11458	47.7 10716	45.1 10145	43.1 9687	41.4 9306			
			60000	117.1 26323	95.1 21381	77.3 17367	58.7 13193	47.7 10716	45.1 10145	42.2 9488	40.0 8983	38.2 8577	36.7 8241			
			100000	100.5 22583	81.6 18343	66.3 14899	50.3 11318	40.9 9193	38.7 8704	36.2 8140	34.3 7707	32.7 7359	31.4 7070			
							50	100	200	500	1000	1200 ⁽¹⁾	1500 ⁽¹⁾	1800 ⁽¹⁾	2100 ⁽¹⁾	
125, 130 4 15/16, 5	22226	757 170000	10000	272.6 61279	221.4 49774	179.8 40429	136.6 30712	111.0 24946	105.1 23618	98.3 22089	93.0 20913	88.8 19968				
			30000	196.1 44074	159.2 35799	129.3 29078	98.3 22089	79.8 17942	75.6 16987	70.7 15887	66.9 15041	63.9 14362				
			40000	179.8 40429	146.1 32839	118.6 26673	90.1 20263	73.2 16458	69.3 15582	64.8 14573	61.4 13798	58.6 13174				
			60000	159.2 35799	129.3 29078	105.1 23618	79.8 17942	64.8 14573	61.4 13798	57.4 12904	54.3 12217	51.9 11665				
			100000	136.6 30712	111.0 24946	90.1 20263	68.5 15393	55.6 12503	52.7 11837	49.2 11071	46.6 10482	44.5 10008				
							50	100	200	500	1000	1200 ⁽¹⁾	1500 ⁽¹⁾	1800 ⁽¹⁾	2100 ⁽¹⁾	

⁽¹⁾Speeds referenced here may be higher than speed rating for seals. Please refer to the charts on pages 57 – 59.

⁽²⁾For speeds greater than thermal reference speed, contact your Timken engineer.

TABLE 27. EC SERIES – ALLOWABLE RADIAL LOAD (kN/LBS.) AT VARIOUS RPM⁽¹⁾

Shaft Diameter	Bearing No.	C	L ₁₀ Life	Speed ⁽²⁾													
				RPM													
mm in.		kN lbs.		50	100	200	500	1000	1200	1500	1800	2100	2400	2700	3000	3200	3500
35 1 1/16, 1 1/2	22208	104 23400	10000	37.5 8435	30.5 6851	24.8 5565	18.8 4227	15.3 3434	14.5 3251	13.5 3041	12.8 2879	12.2 2749	11.7 2641	11.3 2549	11.0 2470	10.8 2422	10.5 2358
			30000	27.0 6067	21.9 4928	17.8 4002	13.5 3041	11.0 2470	10.4 2338	9.7 2187	9.2 2070	8.8 1977	8.4 1899	8.2 1833	7.9 1776	7.7 1742	7.5 1696
			40000	24.8 5565	20.1 4520	16.3 3672	12.4 2789	10.1 2265	9.5 2145	8.9 2006	8.4 1899	8.1 1813	7.7 1742	7.5 1682	7.2 1629	7.1 1598	6.9 1556
			60000	21.9 4928	17.8 4002	14.5 3251	11.0 2470	8.9 2006	8.4 1899	7.9 1776	7.5 1682	7.1 1606	6.9 1543	6.6 1489	6.4 1443	6.3 1415	6.1 1378
			100000	18.8 4227	15.3 3434	12.4 2789	9.4 2119	7.7 1721	7.2 1629	6.8 1524	6.4 1443	6.1 1378	5.9 1323	5.7 1278	5.5 1238	5.4 1214	5.3 1182
40, 45 1 1/16, 1 3/4	22209	109 24500	10000	39.3 8831	31.9 7173	25.9 5827	19.7 4426	16.0 3595	15.1 3404	14.2 3183	13.4 3014	12.8 2878	12.3 2765	11.9 2669	11.5 2586	11.3 2536	11.0 2469
			30000	28.3 6352	22.9 5159	18.6 4191	14.2 3183	11.5 2586	10.9 2448	10.2 2290	9.6 2168	9.2 2070	8.8 1988	8.5 1919	8.3 1860	8.1 1824	7.9 1776
			40000	25.9 5827	21.1 4733	17.1 3844	13.0 2920	10.6 2372	10.0 2246	9.3 2100	8.8 1988	8.4 1899	8.1 1824	7.8 1761	7.6 1706	7.4 1673	7.2 1629
			60000	22.9 5159	18.6 4191	15.1 3404	11.5 2586	9.3 2100	8.8 1988	8.3 1860	7.8 1761	7.5 1681	7.2 1615	6.9 1559	6.7 1511	6.6 1482	6.4 1442
			100000	19.7 4426	16.0 3595	13.0 2920	9.9 2218	8.0 1802	7.6 1706	7.1 1595	6.7 1511	6.4 1442	6.2 1386	6.0 1338	5.8 1296	5.7 1271	5.5 1237
50 1 15/16, 2	22210	117 26300	10000	42.2 9480	34.3 7700	27.8 6255	21.1 4751	17.2 3859	16.3 3654	15.2 3417	14.4 3235	13.7 3089	13.2 2968	12.7 2865	12.3 2776	12.1 2723	11.8 2650
			30000	30.3 6818	24.6 5538	20.0 4498	15.2 3417	12.3 2776	11.7 2628	10.9 2458	10.4 2327	9.9 2222	9.5 2135	9.2 2060	8.9 1996	8.7 1958	8.5 1906
			40000	27.8 6255	22.6 5080	18.4 4127	13.9 3135	11.3 2546	10.7 2411	10.0 2255	9.5 2135	9.1 2038	8.7 1958	8.4 1890	8.1 1831	8.0 1796	7.8 1749
			60000	24.6 5538	20.0 4498	16.3 3654	12.3 2776	10.0 2255	9.5 2135	8.9 1996	8.4 1890	8.0 1805	7.7 1734	7.4 1674	7.2 1622	7.1 1590	6.9 1548
			100000	21.1 4751	17.2 3859	13.9 3135	10.6 2381	8.6 1934	8.1 1831	7.6 1713	7.2 1622	6.9 1548	6.6 1487	6.4 1436	6.2 1391	6.1 1364	5.9 1328
55 2 3/16, 2 1/4	22211	140 31400	10000	50.3 11319	40.9 9194	33.2 7468	25.2 5673	20.5 4608	19.4 4362	18.1 4080	17.2 3863	16.4 3688	15.8 3543	15.2 3420	14.7 3314	14.5 3250	14.1 3164
			30000	36.2 8141	29.4 6612	23.9 5371	18.1 4080	14.7 3314	14.0 3138	13.1 2934	12.4 2778	11.8 2653	11.3 2549	10.9 2460	10.6 2383	10.4 2338	10.1 2276
			40000	33.2 7468	27.0 6066	21.9 4927	16.6 3743	13.5 3040	12.8 2878	12.0 2692	11.3 2549	10.8 2433	10.4 2338	10.0 2257	9.7 2186	9.5 2144	9.3 2088
			60000	29.4 6612	23.9 5371	19.4 4362	14.7 3314	12.0 2692	11.3 2549	10.6 2383	10.0 2257	9.6 2155	9.2 2070	8.9 1998	8.6 1936	8.4 1899	8.2 1849
			100000	25.2 5673	20.5 4608	16.6 3743	12.6 2843	10.3 2309	9.7 2186	9.1 2045	8.6 1936	8.2 1849	7.9 1776	7.6 1714	7.4 1661	7.2 1629	7.1 1586
60, 65 2 7/16, 2 1/2	22213	206 46400	10000	74.4 16726	60.4 13585	49.1 11035	37.3 8383	30.3 6809	28.7 6446	26.8 6029	25.4 5708	24.2 5450	23.3 5236	22.5 5054	21.8 4897	21.4 4803	20.8 4676
			30000	53.5 12030	43.5 9771	35.3 7937	26.8 6029	21.8 4897	20.6 4636	19.3 4336	18.3 4105	17.4 3920	16.8 3766	16.2 3635	15.7 3522	15.4 3455	15.0 3363
			40000	49.1 11035	39.9 8963	32.4 7280	24.6 5531	20.0 4492	18.9 4253	17.7 3978	16.8 3766	16.0 3596	15.4 3455	14.8 3335	14.4 3231	14.1 3169	13.7 3085
			60000	43.5 9771	35.3 7937	28.7 6446	21.8 4897	17.7 3978	16.8 3766	15.7 3522	14.8 3335	14.2 3184	13.6 3059	13.1 2953	12.7 2861	12.5 2806	12.2 2732
			100000	37.3 8383	30.3 6809	24.6 5531	18.7 4201	15.2 3413	14.4 3231	13.4 3022	12.7 2861	12.2 2732	11.7 2624	11.3 2533	10.9 2454	10.7 2407	10.4 2343

⁽¹⁾Speeds referenced here may be higher than speed rating for seals. Please refer to the charts on pages 57 – 59.

⁽²⁾For speeds greater than thermal reference speed, contact your Timken engineer.

Continued on next page.

LOAD RATINGS – *Continued from previous page*

TABLE 27. EC SERIES – ALLOWABLE RADIAL LOAD (kN/LBS.) AT VARIOUS RPM⁽¹⁾ (CONTINUED)

Shaft Diameter	Bearing No.	C	L ₁₀ Life	Speed ⁽²⁾												
				RPM												
mm in.		kN lbs.		50	100	200	500	1000	1200	1500	1800	2100	2400	2700 ⁽¹⁾	3000 ⁽¹⁾	3200 ⁽¹⁾
70, 75 2 1/16, 2 3/4, 2 15/16, 3	22215	222 49900	10000	80.0 17987	65.0 14610	52.8 11867	40.1 9015	32.6 7322	30.8 6933	28.8 6484	27.3 6139	26.1 5861	25.0 5631	24.2 5436	23.4 5266	23.0 5166
			30000	57.5 12937	46.7 10508	38.0 8535	28.8 6484	23.4 5266	22.2 4986	20.7 4663	19.6 4415	18.8 4216	18.0 4050	17.4 3909	16.8 3788	16.5 3715
			40000	52.8 11867	42.9 9639	34.8 7829	26.5 5948	21.5 4831	20.3 4574	19.0 4278	18.0 4050	17.2 3867	16.5 3715	16.0 3586	15.5 3475	15.2 3408
			60000	46.7 10508	38.0 8535	30.8 6933	23.4 5266	19.0 4278	18.0 4050	16.8 3788	16.0 3586	15.2 3424	14.6 3290	14.1 3175	13.7 3077	13.4 3018
			100000	40.1 9015	32.6 7322	26.5 5948	20.1 4518	16.3 3670	15.5 3475	14.5 3250	13.7 3077	13.1 2938	12.6 2822	12.1 2724	11.7 2639	11.5 2589
							50	100	200	500	1000	1200	1500	1800	2100 ⁽¹⁾	2400 ⁽¹⁾
80, 85, 90 3 1/16, 3 3/4, 3 7/16, 3 1/2	22218	355 79700	10000	127.8 28729	103.8 23335	84.3 18954	64.0 14399	52.0 11695	49.3 11073	46.1 10356	43.6 9805	41.6 9362	40.0 8994	38.6 8682		
			30000	91.9 20663	74.7 16783	60.6 13632	46.1 10356	37.4 8412	35.4 7964	33.1 7448	31.4 7052	29.9 6733	28.8 6469	27.8 6244		
			40000	84.3 18954	68.5 15396	55.6 12505	42.3 9500	34.3 7716	32.5 7305	30.4 6832	28.8 6469	27.5 6176	26.4 5934	25.5 5728		
			60000	74.7 16783	60.6 13632	49.3 11073	37.4 8412	30.4 6832	28.8 6469	26.9 6050	25.5 5728	24.3 5469	23.4 5254	22.6 5072		
			100000	64.0 14399	52.0 11695	42.3 9500	32.1 7216	26.1 5862	24.7 5550	23.1 5190	21.9 4914	20.9 4692	20.1 4508	19.4 4351		
							50	100	200	500	1000	1200	1500	1800 ⁽¹⁾	2100 ⁽¹⁾	2400 ⁽¹⁾
100 3 11/16, 3 3/4, 3 15/16, 4	22220	435 97700	10000	156.7 35218	127.2 28606	103.4 23235	78.5 17651	63.8 14337	60.4 13574	56.5 12695	53.5 12019	51.0 11476	49.0 11025	47.3 10642		
			30000	112.7 25329	91.5 20574	74.3 16711	56.5 12695	45.9 10311	43.4 9762	40.6 9130	38.5 8644	36.7 8254	35.3 7930	34.0 7654		
			40000	103.4 23235	84.0 18873	68.2 15329	51.8 11645	42.1 9459	39.8 8955	37.3 8375	35.3 7930	33.7 7571	32.4 7274	31.2 7021		
			60000	91.5 20574	74.3 16711	60.4 13574	45.9 10311	37.3 8375	35.3 7930	33.0 7416	31.2 7021	29.8 6704	28.7 6441	27.7 6217		
			100000	78.5 17651	63.8 14337	51.8 11645	39.3 8846	32.0 7185	30.3 6803	28.3 6362	26.8 6024	25.6 5752	24.6 5526	23.7 5334		
							50	100	200	500	1000	1200	1500 ⁽¹⁾	1800 ⁽¹⁾	2100 ⁽¹⁾	2400 ⁽¹⁾
110, 115 4 1/16, 4 1/2	22222	555 125000	10000	200.4 45058	162.8 36599	132.2 29727	100.5 22583	81.6 18343	77.3 17367	72.2 16242	68.4 15377	65.3 14683	62.7 14106			
			30000	144.2 32407	117.1 26323	95.1 21381	72.2 16242	58.7 13193	55.6 12490	52.0 11682	49.2 11060	47.0 10560	45.1 10145			
			40000	132.2 29727	107.4 24146	87.2 19613	66.3 14899	53.8 12102	51.0 11458	47.7 10716	45.1 10145	43.1 9687	41.4 9306			
			60000	117.1 26323	95.1 21381	77.3 17367	58.7 13193	47.7 10716	45.1 10145	42.2 9488	40.0 8983	38.2 8577	36.7 8241			
			100000	100.5 22583	81.6 18343	66.3 14899	50.3 11318	40.9 9193	38.7 8704	36.2 8140	34.3 7707	32.7 7359	31.4 7070			
							50	100	200	500	1000	1200 ⁽¹⁾	1500 ⁽¹⁾	1800 ⁽¹⁾	2100 ⁽¹⁾	
125, 130 4 15/16, 5	22226	757 170000	10000	272.6 61279	221.4 49774	179.8 40429	136.6 30712	111.0 24946	105.1 23618	98.3 22089	93.0 20913	88.8 19968				
			30000	196.1 44074	159.2 35799	129.3 29078	98.3 22089	79.8 17942	75.6 16987	70.7 15887	66.9 15041	63.9 14362				
			40000	179.8 40429	146.1 32839	118.6 26673	90.1 20263	73.2 16458	69.3 15582	64.8 14573	61.4 13798	58.6 13174				
			60000	159.2 35799	129.3 29078	105.1 23618	79.8 17942	64.8 14573	61.4 13798	57.4 12904	54.3 12217	51.9 11665				
			100000	136.6 30712	111.0 24946	90.1 20263	68.5 15393	55.6 12503	52.7 11837	49.2 11071	46.6 10482	44.5 10008				
							50	100	200	500	1000	1200 ⁽¹⁾	1500 ⁽¹⁾	1800 ⁽¹⁾	2100 ⁽¹⁾	

⁽¹⁾Speeds referenced here may be higher than speed rating for seals. Please refer to the charts on pages 57 – 59.

⁽²⁾For speeds greater than thermal reference speed, contact your Timken engineer.

Continued on next page.

Continued from previous page.

Shaft Diameter	Bearing No.	C	L ₁₀ Life	Speed ⁽²⁾					
				RPM					
mm in.		kN lbs.		50	100	200	500	1000 ⁽¹⁾	1200 ⁽¹⁾
140, 150 5 7/16, 5 1/2, 5 15/16, 6	23230	1270 286000	10000	458.6 103094	372.5 83738	302.6 68016	229.8 51669	186.7 41968	176.8 39735
			30000	329.8 74147	267.9 60226	217.6 48919	165.3 37162	134.3 30185	127.1 28578
			40000	302.6 68016	245.8 55247	199.6 44874	151.6 34089	123.2 27689	116.6 26215
			60000	267.9 60226	217.6 48919	176.8 39735	134.3 30185	109.1 24518	103.3 23213
			100000	229.8 51669	186.7 41968	151.6 34089	115.2 25896	93.6 21034	88.6 19914
							50	100	200
170, 180 6 7/16, 6 1/2, 6 15/16, 7	23234	1660 373000	10000	598.1 134454	485.8 109211	394.6 88707	299.8 67387	243.5 54735	
			30000	430.2 96703	349.4 78547	283.8 63800	215.6 48466	175.1 39367	
			40000	394.6 88707	320.5 72052	260.3 58525	197.8 44459	160.6 36112	
			60000	349.4 78547	283.8 63800	230.5 51822	175.1 39367	142.2 31976	
			100000	299.8 67387	243.5 54735	197.8 44459	150.2 33773	122.0 27433	
							50	100	200

⁽¹⁾Speeds referenced here may be higher than speed rating for seals. Please refer to the charts on pages 57 – 59.

⁽²⁾For speeds greater than thermal reference speed, contact your Timken engineer.

LOAD RATINGS – continued

TABLE 28. TA - ALLOWABLE RADIAL LOAD (kN/LBS.) AT VARIOUS RPM⁽¹⁾ (CONTINUED)

Shaft Diameter	Bearing No.	C	L ₁₀ Life	Speed ⁽²⁾															
				RPM															
mm in.		kN lbs.		50	100	200	500	1000	1200	1500	1800	2100	2400	2700	3000	3200	3500		
40 1 1/16, 1 1/2	22209	109 24500	10000	39.3 8831	31.9 7173	25.9 5827	19.7 4426	16.0 3595	15.1 3404	14.2 3183	13.4 3014	12.8 2878	12.3 2765	11.9 2669	11.5 2586	11.3 2536	11.0 2469		
			30000	28.3 6352	22.9 5159	18.6 4191	14.2 3183	11.5 2586	10.9 2448	10.2 2290	9.6 2168	9.2 2070	8.8 1988	8.5 1919	8.3 1860	8.1 1824	8.1 1824	7.9 1776	
			40000	25.9 5827	21.1 4733	17.1 3844	13.0 2920	10.6 2372	10.0 2246	9.3 2100	8.8 1988	8.4 1860	8.1 1761	7.8 1824	7.8 1761	7.6 1706	7.4 1673	7.4 1673	7.2 1629
			60000	22.9 5159	18.6 4191	15.1 3404	11.5 2586	9.3 2100	8.8 1988	8.3 1860	7.8 1761	7.5 1681	7.2 1615	6.9 1559	6.7 1511	6.7 1511	6.6 1482	6.6 1482	6.4 1442
			100000	19.7 4426	16.0 3595	13.0 2920	9.9 2218	8.0 1802	7.6 1706	7.1 1595	6.7 1511	6.4 1442	6.2 1386	6.0 1338	6.0 1296	5.8 1271	5.7 1271	5.7 1271	5.5 1237
							50	100	200	500	1000	1200	1500	1800	2100	2400	2700	3000	3200
45 1 1/16, 1 3/4	22210	117 26300	10000	42.2 9480	34.3 7700	27.8 6255	21.1 4751	17.2 3859	16.3 3654	15.2 3417	14.4 3235	13.7 3089	13.2 2968	12.7 2865	12.3 2776	12.1 2723	11.8 2650		
			30000	30.3 6818	24.6 5538	20.0 4498	15.2 3417	12.3 2776	11.7 2628	10.9 2458	10.4 2327	9.9 2222	9.5 2135	9.2 2060	8.9 1996	8.9 1996	8.7 1958	8.5 1906	
			40000	27.8 6255	22.6 5080	18.4 4127	13.9 3135	11.3 2546	10.7 2411	10.0 2255	9.5 2135	9.1 2038	8.7 1958	8.4 1890	8.1 1831	8.1 1831	8.0 1796	8.0 1796	7.8 1749
			60000	24.6 5538	20.0 4498	16.3 3654	12.3 2776	10.0 2255	9.5 2135	8.9 1996	8.4 1890	8.0 1805	7.7 1734	7.4 1674	7.2 1622	7.1 1590	7.1 1590	6.9 1548	
			100000	21.1 4751	17.2 3859	13.9 3135	10.6 2381	8.6 1934	8.1 1831	7.6 1713	7.2 1622	6.9 1548	6.6 1487	6.4 1436	6.2 1391	6.1 1364	6.1 1364	5.9 1328	
							50	100	200	500	1000	1200	1500	1800	2100	2400	2700	3000	3200
50 1 1/16, 2	22211	140 31400	10000	50.3 11319	40.9 9194	33.2 7468	25.2 5673	20.5 4608	19.4 4362	18.1 4080	17.2 3863	16.4 3688	15.8 3543	15.2 3420	14.7 3314	14.5 3250	14.1 3164		
			30000	36.2 8141	29.4 6612	23.9 5371	18.1 4080	14.7 3314	14.0 3138	13.1 2934	12.4 2778	11.8 2653	11.3 2549	10.9 2460	10.6 2383	10.4 2338	10.4 2338	10.1 2276	
			40000	33.2 7468	27.0 6066	21.9 4927	16.6 3743	13.5 3040	12.8 2878	12.0 2692	11.3 2549	10.8 2433	10.4 2338	10.0 2257	9.7 2186	9.5 2144	9.5 2144	9.3 2088	
			60000	29.4 6612	23.9 5371	19.4 4362	14.7 3314	12.0 2692	11.3 2549	10.6 2383	10.0 2257	9.6 2155	9.2 2070	8.9 1998	8.6 1936	8.4 1899	8.4 1899	8.2 1849	
			100000	25.2 5673	20.5 4608	16.6 3743	12.6 2843	10.3 2309	9.7 2186	9.1 2045	8.6 1936	8.2 1849	7.9 1776	7.6 1714	7.4 1661	7.2 1629	7.2 1629	7.1 1586	
							50	100	200	500	1000	1200	1500	1800	2100	2400	2700	3000	3200 ⁽¹⁾
55 –	22212	169 38100	10000	61.1 13734	49.6 11155	40.3 9061	30.6 6883	24.9 5591	23.5 5293	22.0 4951	20.8 4687	19.9 4475	19.1 4300	18.5 4150	17.9 4021	17.5 3944	17.1 3839		
			30000	43.9 9878	35.7 8023	29.0 6517	22.0 4951	17.9 4021	16.9 3807	15.8 3561	15.0 3371	14.3 3219	13.8 3092	13.3 2985	12.9 2892	12.6 2837	12.6 2837	12.3 2761	
			40000	40.3 9061	32.7 7360	26.6 5978	20.2 4541	16.4 3689	15.5 3492	14.5 3266	13.8 3092	13.1 2953	12.6 2837	12.2 2738	11.8 2653	11.6 2602	11.6 2602	11.3 2533	
			60000	35.7 8023	29.0 6517	23.5 5293	17.9 4021	14.5 3266	13.8 3092	12.9 2892	12.2 2738	11.6 2614	11.2 2512	10.8 2425	10.4 2349	10.2 2304	10.2 2304	10.0 2243	
			100000	30.6 6883	24.9 5591	20.2 4541	15.3 3450	12.5 2802	11.8 2653	11.0 2481	10.4 2349	10.0 2243	9.6 2155	9.3 2080	9.0 2015	8.8 1977	8.8 1977	8.6 1924	
							50	100	200	500	1000	1200	1500	1800	2100	2400	2700	3000 ⁽¹⁾	3200 ⁽¹⁾
60 2 3/16, 2 1/4	22213	206 46400	10000	74.4 16726	60.4 13585	49.1 11035	37.3 8383	30.3 6809	28.7 6446	26.8 6029	25.4 5708	24.2 5450	23.3 5236	22.5 5054	21.8 4897	21.4 4803	20.8 4676		
			30000	53.5 12030	43.5 9771	35.3 7937	26.8 6029	21.8 4897	20.6 4636	19.3 4336	18.3 4105	17.4 3920	16.8 3766	16.2 3635	15.7 3522	15.4 3455	15.4 3455	15.0 3363	
			40000	49.1 11035	39.9 8963	32.4 7280	24.6 5531	20.0 4492	18.9 4253	17.7 3978	16.8 3766	16.0 3596	15.4 3455	14.8 3335	14.4 3231	14.1 3169	14.1 3169	13.7 3085	
			60000	43.5 9771	35.3 7937	28.7 6446	21.8 4897	17.7 3978	16.8 3766	15.7 3522	14.8 3335	14.2 3184	13.6 3059	13.1 2953	12.7 2861	12.5 2806	12.5 2806	12.2 2732	
			100000	37.3 8383	30.3 6809	24.6 5531	18.7 4201	15.2 3413	14.4 3231	13.4 3022	12.7 2861	12.2 2732	11.7 2624	11.3 2533	10.9 2454	10.7 2407	10.7 2407	10.4 2343	
							50	100	200	500	1000	1200	1500	1800	2100	2400	2700	3000 ⁽¹⁾	3200 ⁽¹⁾

⁽¹⁾Speeds referenced here may be higher than speed rating for seals. Please refer to the charts on pages 57 – 59.
⁽²⁾For speeds greater than thermal reference speed, contact your Timken engineer.

Continued on next page.

Continued from previous page.

Shaft Diameter	Bearing No.	C	L ₁₀ Life	Speed ⁽²⁾												
				RPM												
mm in.		kN lbs.		50	100	200	500	1000	1200	1500	1800	2100	2400	2700 ⁽¹⁾	3000 ⁽¹⁾	3200 ⁽¹⁾
65 2 7/16, 2 1/2	22215	222 49900	10000	80.0 17987	65.0 14610	52.8 11867	40.1 9015	32.6 7322	30.8 6933	28.8 6484	27.3 6139	26.1 5861	25.0 5631	24.2 5436	23.4 5266	23.0 5166
			30000	57.5 12937	46.7 10508	38.0 8535	28.8 6484	23.4 5266	22.2 4986	20.7 4663	19.6 4415	18.8 4216	18.0 4050	17.4 3909	16.8 3788	16.5 3715
			40000	52.8 11867	42.9 9639	34.8 7829	26.5 5948	21.5 4831	20.3 4574	19.0 4278	18.0 4050	17.2 3867	16.5 3715	16.0 3586	15.5 3475	15.2 3408
			60000	46.7 10508	38.0 8535	30.8 6933	23.4 5266	19.0 4278	18.0 4050	16.8 3788	16.0 3586	15.2 3424	14.6 3290	14.1 3175	13.7 3077	13.4 3018
			100000	40.1 9015	32.6 7322	26.5 5948	20.1 4518	16.3 3670	15.5 3475	14.5 3250	13.7 3077	13.1 2938	12.6 2822	12.1 2724	11.7 2639	11.5 2589
							50	100	200	500	1000	1200	1500	1800	2100	2400 ⁽¹⁾
70 2 11/16, 2 3/4	22216	254 57200	10000	91.7 20619	74.5 16748	60.5 13603	46.0 10334	37.3 8394	35.4 7947	33.1 7432	31.3 7037	29.9 6719	28.7 6455	27.7 6231	26.9 6037	26.9 6037
			30000	66.0 14829	53.6 12045	43.5 9784	33.1 7432	26.9 6037	25.4 5716	23.8 5346	22.5 5061	21.5 4832	20.7 4643	19.9 4481	19.3 4342	
			40000	60.5 13603	49.1 11049	39.9 8975	30.3 6818	24.6 5538	23.3 5243	21.8 4904	20.7 4643	19.7 4433	18.9 4259	18.3 4111	17.7 3983	
			60000	53.6 12045	43.5 9784	35.4 7947	26.9 6037	21.8 4904	20.7 4643	19.3 4342	18.3 4111	17.5 3925	16.8 3771	16.2 3640	15.7 3527	
			100000	46.0 10334	37.3 8394	30.3 6818	23.0 5179	18.7 4207	17.7 3983	16.6 3725	15.7 3527	15.0 3367	14.4 3235	13.9 3123	13.5 3026	
							50	100	200	500	1000	1200	1500	1800	2100 ⁽¹⁾	2400 ⁽¹⁾
75 2 15/16, 3	22217	297 66900	10000	107.3 24115	87.1 19588	70.8 15910	53.8 12086	43.7 9817	41.3 9295	38.7 8693	36.6 8230	35.0 7858	33.6 7550	32.4 7287	32.4 7287	32.4 7287
			30000	77.1 17344	62.7 14088	50.9 11443	38.7 8693	31.4 7061	29.7 6685	27.8 6252	26.3 5919	25.1 5652	24.2 5430	23.3 5241		
			40000	70.8 15910	57.5 12923	46.7 10497	35.5 7974	28.8 6477	27.3 6132	25.5 5735	24.2 5430	23.1 5184	22.2 4981	21.4 4808		
			60000	62.7 14088	50.9 11443	41.3 9295	31.4 7061	25.5 5735	24.2 5430	22.6 5078	21.4 4808	20.4 4591	19.6 4410	18.9 4257		
			100000	53.8 12086	43.7 9817	35.5 7974	26.9 6057	21.9 4920	20.7 4658	19.4 4357	18.3 4125	17.5 3938	16.8 3784	16.2 3652		
							50	100	200	500	1000	1200	1500	1800	2100 ⁽¹⁾	2400 ⁽¹⁾
80 3 3/16, 3 1/4	22218	355 79700	10000	127.8 28729	103.8 23335	84.3 18954	64.0 14399	52.0 11695	49.3 11073	46.1 10356	43.6 9805	41.6 9362	40.0 8994	38.6 8682	38.6 8682	38.6 8682
			30000	91.9 20663	74.7 16783	60.6 13632	46.1 10356	37.4 8412	35.4 7964	33.1 7448	31.4 7052	29.9 6733	28.8 6469	27.8 6244		
			40000	84.3 18954	68.5 15396	55.6 12505	42.3 9500	34.3 7716	32.5 7305	30.4 6832	28.8 6469	27.5 6176	26.4 5934	25.5 5728		
			60000	74.7 16783	60.6 13632	49.3 11073	37.4 8412	30.4 6832	28.8 6469	26.9 6050	25.5 5728	24.3 5469	23.4 5254	22.6 5072		
			100000	64.0 14399	52.0 11695	42.3 9500	32.1 7216	26.1 5862	24.7 5550	23.1 5190	21.9 4914	20.9 4692	20.1 4508	19.4 4351		
							50	100	200	500	1000	1200	1500	1800	2100 ⁽¹⁾	2400 ⁽¹⁾
85 -	22219	385 86600	10000	138.9 31216	112.8 25356	91.6 20595	69.6 15645	56.5 12708	53.5 12032	50.1 11252	47.4 10654	45.2 10172	43.5 9773	42.0 9433	42.0 9433	42.0 9433
			30000	99.9 22452	81.1 18236	65.9 14813	50.1 11252	40.7 9140	38.5 8653	36.0 8093	34.1 7662	32.5 7316	31.3 7029	30.2 6785		
			40000	91.6 20595	74.4 16729	60.4 13588	45.9 10322	37.3 8384	35.3 7938	33.0 7424	31.3 7029	29.9 6711	28.7 6448	27.7 6224		
			60000	81.1 18236	65.9 14813	53.5 12032	40.7 9140	33.0 7424	31.3 7029	29.2 6574	27.7 6224	26.4 5942	25.4 5709	24.5 5511		
			100000	69.6 15645	56.5 12708	45.9 10322	34.9 7841	28.3 6369	26.8 6030	25.1 5640	23.7 5339	22.7 5098	21.8 4898	21.0 4728		
							50	100	200	500	1000	1200	1500	1800	2100 ⁽¹⁾	2400 ⁽¹⁾

⁽¹⁾Speeds referenced here may be higher than speed rating for seals. Please refer to the charts on pages 57 – 59.

⁽²⁾For speeds greater than thermal reference speed, contact your Timken engineer.

Continued on next page.

LOAD RATINGS – continued

TABLE 28. TA - ALLOWABLE RADIAL LOAD (kN/LBS.) AT VARIOUS RPM⁽¹⁾ (CONTINUED)

Shaft Diameter	Bearing No.	C	L ₁₀ Life	Speed ⁽²⁾										
				RPM										
mm in.		kN lbs.		50	100	200	500	1000	1200	1500	1800 ⁽¹⁾	2100 ⁽¹⁾	2400 ⁽¹⁾	2700 ⁽¹⁾
90 3 7/16, 3 1/2	22220	435 97700	10000	156.7 35218	127.2 28606	103.4 23235	78.5 17651	63.8 14337	60.4 13574	56.5 12695	53.5 12019	51.0 11476	49.0 11025	47.3 10642
			30000	112.7 25329	91.5 20574	74.3 16711	56.5 12695	45.9 10311	43.4 9762	40.6 9130	38.5 8644	36.7 8254	35.3 7930	34.0 7654
			40000	103.4 23235	84.0 18873	68.2 15329	51.8 11645	42.1 9459	39.8 8955	37.3 8375	35.3 7930	33.7 7571	32.4 7274	31.2 7021
			60000	91.5 20574	74.3 16711	60.4 13574	45.9 10311	37.3 8375	35.3 7930	33.0 7416	31.2 7021	29.8 6704	28.7 6441	27.7 6217
			100000	78.5 17651	63.8 14337	51.8 11645	39.3 8846	32.0 7185	30.3 6803	28.3 6362	26.8 6024	25.6 5752	24.6 5526	23.7 5334
							50	100	200	500	1000	1200	1500 ⁽¹⁾	1800 ⁽¹⁾
100 3 15/16, 4	22222	555 125000	10000	200.4 45058	162.8 36599	132.2 29727	100.5 22583	81.6 18343	77.3 17367	72.2 16242	68.4 15377	65.3 14683	62.7 14106	
			30000	144.2 32407	117.1 26323	95.1 21381	72.2 16242	58.7 13193	55.6 12490	52.0 11682	49.2 11060	47.0 10560	45.1 10145	
			40000	132.2 29727	107.4 24146	87.2 19613	66.3 14899	53.8 12102	51.0 11458	47.7 10716	45.1 10145	43.1 9687	41.4 9306	
			60000	117.1 26323	95.1 21381	77.3 17367	58.7 13193	47.7 10716	45.1 10145	42.2 9488	40.0 8983	38.2 8577	36.7 8241	
			100000	100.5 22583	81.6 18343	66.3 14899	50.3 11318	40.9 9193	38.7 8704	36.2 8140	34.3 7707	32.7 7359	31.4 7070	
							50	100	200	500	1000	1200	1500 ⁽¹⁾	1800 ⁽¹⁾
110 4 3/16, 4 1/4	22224	647 145000	10000	232.5 52268	188.8 42455	153.4 34484	116.5 26196	94.6 21278	89.6 20145	83.8 18841	79.3 17838	75.8 17032	72.8 16363	
			30000	167.2 37592	135.8 30534	110.3 24802	83.8 18841	68.1 15303	64.5 14489	60.3 13551	57.1 12829	54.5 12250	52.4 11769	
			40000	153.4 34484	124.6 28010	101.2 22751	76.9 17283	62.4 14038	59.1 13291	55.3 12430	52.4 11769	50.0 11237	48.0 10796	
			60000	135.8 30534	110.3 24802	89.6 20145	68.1 15303	55.3 12430	52.4 11769	49.0 11007	46.4 10421	44.3 9950	42.5 9559	
			100000	116.5 26196	94.6 21278	76.9 17283	58.4 13129	47.4 10664	44.9 10097	42.0 9443	39.8 8940	38.0 8536	36.5 8201	
							50	100	200	500	1000	1200 ⁽¹⁾	1500 ⁽¹⁾	1800 ⁽¹⁾
115 4 7/16, 4 1/2	22226	757 170000	10000	272.6 61279	221.4 49774	179.8 40429	136.6 30712	111.0 24946	105.1 23618	98.3 22089	93.0 20913	88.8 19968		
			30000	196.1 44074	159.2 35799	129.3 29078	98.3 22089	79.8 17942	75.6 16987	70.7 15887	66.9 15041	63.9 14362		
			40000	179.8 40429	146.1 32839	118.6 26673	90.1 20263	73.2 16458	69.3 15582	64.8 14573	61.4 13798	58.6 13174		
			60000	159.2 35799	129.3 29078	105.1 23618	79.8 17942	64.8 14573	61.4 13798	57.4 12904	54.3 12217	51.9 11665		
			100000	136.6 30712	111.0 24946	90.1 20263	68.5 15393	55.6 12503	52.7 11837	49.2 11071	46.6 10482	44.5 10008		
							50	100	200	500	1000 ⁽¹⁾	1200 ⁽¹⁾	1500 ⁽¹⁾	1800 ⁽¹⁾
125 4 15/16, 5	22228	863 194000	10000	311.1 69931	252.7 56801	205.2 46137	155.9 35048	126.6 28468	119.9 26953	112.1 25208	106.2 23866			
			30000	223.7 50296	181.7 40853	147.6 33183	112.1 25208	91.1 20475	86.2 19385	80.6 18130	76.4 17165			
			40000	205.2 46137	166.7 37475	135.4 30439	102.9 23123	83.5 18782	79.1 17782	74.0 16631	70.0 15746			
			60000	181.7 40853	147.6 33183	119.9 26953	91.1 20475	74.0 16631	70.0 15746	65.5 14726	62.0 13942			
			100000	155.9 35048	126.6 28468	102.9 23123	78.1 17566	63.5 14268	60.1 13508	56.2 12634	53.2 11961			
							50	100	200	500	1000 ⁽¹⁾	1200 ⁽¹⁾	1500 ⁽¹⁾	1800 ⁽¹⁾

⁽¹⁾Speeds referenced here may be higher than speed rating for seals. Please refer to the charts on pages 57 – 59.
⁽²⁾For speeds greater than thermal reference speed, contact your Timken engineer.

Continued on next page.

Continued from previous page.

Shaft Diameter	Bearing No.	C	L ₁₀ Life	Speed ⁽²⁾						
				RPM						
mm in.		kN lbs.		50.0	100.0	200.0	500.0	1000.0	1200.0	1500.0
135 5 3/16, 5 1/4	23130	1000 225000	10000	360.8	293.0	238.0	180.8	146.9	139.0	130.0
				81105.0	65878.0	53509.0	40649.0	33017.0	31260.0	29236.0
				259.5	210.8	171.2	130.0	105.6	100.0	93.5
				58333.0	47381.0	38485.0	29236.0	23747.0	22483.0	21027.0
				238.0	193.3	157.0	119.3	96.9	91.7	85.8
				53509.0	43463.0	35303.0	26818.0	21783.0	20624.0	19288.0
210.8	171.2	139.0	105.6	85.8	81.2	76.0				
47381.0	38485.0	31260.0	23747.0	19288.0	18262.0	17079.0				
180.8	146.9	119.3	90.6	73.6	69.7	65.2				
40649.0	33017.0	26818.0	20373.0	16548.0	15667.0	14652.0				
140 5 3/8, 5 7/16, 5 1/2	23132	1160 261000	10000	418.1	339.6	275.8	209.5	170.2	161.1	150.7
				94072.4	76409.0	62062.1	47144.6	38292.6	36254.1	33906.4
				300.7	244.2	198.4	150.7	122.4	115.9	108.4
				67656.8	54953.3	44635.0	33906.4	27540.0	26074.0	24385.5
				275.8	224.0	182.0	138.2	112.3	106.3	99.4
				62062.1	50409.0	40944.0	31102.6	25262.6	23917.8	22369.0
244.2	198.4	161.1	122.4	99.4	94.1	88.0				
54953.3	44635.0	36254.1	27540.0	22369.0	21178.2	19806.7				
209.5	170.2	138.2	105.0	85.3	80.8	75.5				
47144.6	38292.6	31102.6	23626.7	19190.4	18168.9	16992.3				
150 5 13/16, 5 7/8, 5 15/16, 6	23134	1220 274000	10000	439.7	357.2	290.1	220.4	179.0	169.5	
				98758.0	80214.8	65153.3	49492.9	40199.9	38059.9	
				316.3	256.9	208.6	158.5	128.7	121.9	111.8
				71026.7	57690.4	46858.2	35595.2	28911.7	27372.7	
				290.1	235.6	191.4	145.4	118.1	111.8	104.6
				65153.3	52919.8	42983.4	32651.7	26520.9	25109.1	
256.9	208.6	169.5	128.7	104.6	99.0	93.5				
57690.4	46858.2	38059.9	28911.7	23483.1	22233.0					
220.4	179.0	145.4	110.4	89.7	84.9	79.4				
49492.9	40199.9	32651.7	24803.5	20146.3	19073.8					
160 6 3/16, 6 3/8, 6 7/16, 6 1/2	23136	1410 317000	10000	508.2	412.8	335.3	254.7	206.9	195.9	
				114256.6	92803.2	75378.1	57260.0	46508.6	44032.8	
				365.5	296.9	241.1	183.2	148.8	140.9	132.9
				82173.3	66744.0	54211.9	41181.3	33448.9	31668.4	
				335.3	272.3	221.2	168.0	136.5	129.2	122.2
				75378.1	61224.0	49728.9	37775.9	30682.9	29049.6	
296.9	241.1	195.9	148.8	120.8	114.4	108.0				
66744.0	54211.9	44032.8	33448.9	27168.4	25722.2					
254.7	206.9	168.0	127.6	103.7	98.2	92.7				
57260.0	46508.6	37775.9	28696.0	23307.9	22067.2					
170 6 13/16, 6 7/8, 6 15/16, 7	23138	1630 366000	10000	587.5	477.2	387.6	294.4	239.1	226.4	
				131917.7	107148.2	87029.6	66110.9	53697.6	50839.1	
				422.5	343.2	278.8	211.8	172.0	162.8	153.5
				94875.1	77060.9	62591.6	47546.9	38619.3	36563.5	
				387.6	314.8	255.7	194.2	157.8	149.4	141.1
				87029.6	70688.5	57415.7	43615.1	35425.7	33539.9	
343.2	278.8	226.4	172.0	139.7	132.3	125.0				
77060.9	62591.6	50839.1	38619.3	31368.0	29698.2					
294.4	239.1	194.2	147.6	119.8	113.5	107.2				
66110.9	53697.6	43615.1	33131.6	26910.7	25478.2					

⁽¹⁾Speeds referenced here may be higher than speed rating for seals. Please refer to the charts on pages 57 – 59.

⁽²⁾For speeds greater than thermal reference speed, contact your Timken engineer.

Continued on next page.

LOAD RATINGS – continued

TABLE 28. TA - ALLOWABLE RADIAL LOAD (kN/LBS.) AT VARIOUS RPM⁽¹⁾ (CONTINUED)

Shaft Diameter	Bearing No.	C	L ₁₀ Life	Speed ⁽²⁾					
				RPM					
mm in.		kN lbs.		50.0	100.0	200.0	500.0	1000.0	1200.0
180 7 1/8, 7 3/16, 7 1/4	23140	1660 373000	10000	598.3 134440.7	486.0 109197.5	394.7 88694.1	299.8 67375.3	243.5 54724.6	230.6 51811.5
			30000	430.3 96689.7	349.5 78534.8	283.9 63788.7	215.6 48456.3	175.2 39357.9	165.8 37262.8
			40000	394.7 88694.1	320.6 72040.5	260.4 58513.8	197.8 44449.3	160.7 36103.3	152.1 34181.4
			60000	349.5 78534.8	283.9 63788.7	230.6 51811.5	175.2 39357.9	142.3 31967.9	134.7 30266.2
			100000	299.8 67375.3	243.5 54724.6	197.8 44449.3	150.3 33765.3	122.1 27425.4	115.6 25965.5
				50.0	100.0	200.0	500.0	1000.0	
200 7 13/16, 7 7/8, 7 15/16, 8	23144	1940 436000	10000	699.2 157147.8	567.9 127641.1	461.3 103674.6	350.4 78755.0	284.6 63967.6	
			30000	502.9 113020.6	408.5 91799.4	331.8 74562.7	252.0 56640.6	204.7 46005.5	
			40000	461.3 103674.6	374.7 84208.2	304.3 68396.9	231.2 51956.8	187.8 42201.2	
			60000	408.5 91799.4	331.8 74562.7	269.5 60562.5	204.7 46005.5	166.3 37367.3	
			100000	350.4 78755.0	284.6 63967.6	231.2 51956.8	175.6 39468.3	142.6 32057.6	
				50.0	100.0	200.0	500.0	1000.0	
220 8 7/16, 8 1/2, 8 15/16, 9	23148	2200 495000	10000	792.9 178413.3	644.1 144913.6	523.1 117703.0	397.4 89412.3		
			30000	570.3 128314.7	463.2 104221.8	376.2 84652.6	285.8 64305.2		
			40000	523.1 117703.0	424.9 95603.3	345.1 77652.4	262.2 58987.6		
			60000	463.2 104221.8	376.2 84652.6	305.6 68757.9	232.1 52231.0		
			100000	397.4 89412.3	322.8 72623.8	262.2 58987.6	199.2 44809.2		
				50.0	100.0	200.0	500.0		
240 9 7/16, 9 1/2	23152	2440 549000	10000	879.5 197876.5	714.3 160722.3	580.2 130544.4	440.7 99166.3		
			30000	632.5 142312.7	513.7 115591.4	417.3 93887.4	317.0 71320.4		
			40000	580.2 130544.4	471.3 106032.8	382.8 86123.6	290.8 65422.7		
			60000	513.7 115591.4	417.3 93887.4	338.9 76258.7	257.5 57928.9		
			100000	440.7 99166.3	358.0 80546.4	290.8 65422.7	220.9 49697.5		
				50.0	100.0	200.0	500.0		
260 9 15/16, 10, 10 7/16, 10 1/2	23156	2530 569000	10000	911.9 205085.1	740.7 166577.4	601.6 135300.1	457.0 102778.9		
			30000	655.8 147497.1	532.7 119802.4	432.7 97307.7	328.7 73918.6		
			40000	601.6 135300.1	488.6 109895.5	396.9 89261.1	301.5 67806.0		
			60000	532.7 119802.4	432.7 97307.7	351.4 79036.8	267.0 60039.3		
			100000	457.0 102778.9	371.2 83480.7	301.5 67806.0	229.0 51507.9		
				50.0	100.0	200.0	500.0		

⁽¹⁾ Speeds referenced here may be higher than speed ratings for seals. Please refer to the charts on page 57 – 59.

⁽²⁾ For speeds greater than thermal reference speed, contact your Timken engineer.

Continued on next page.

Continued from previous page.

Shaft Diameter	Bearing No.	C	L ₁₀ Life	Speed ⁽²⁾			
				RPM			
mm in.		kN lbs.		50.0	100.0	200.0	500.0
280 10 15/16, 11	23160	3070 690000	10000	1106.5 248697.3	898.8 202000.7	730.0 164072.2	554.5 124635.3
			30000	795.8 178862.9	646.4 145278.8	525.0 118000.6	398.8 89637.6
			40000	730.0 164072.2	592.9 133265.2	481.6 108242.8	365.8 82225.2
			60000	646.4 145278.8	525.0 118000.6	426.4 95844.3	323.9 72806.9
			100000	554.5 124635.3	450.4 101233.2	365.8 82225.2	277.9 62461.3
						50.0	100.0
300 11 7/16, 11 1/2, 11 15/16, 12	23164	3650 821000	10000	1315.6 295913.7	1068.6 240351.6	867.9 195222.1	659.3 148297.9
			30000	946.2 212820.9	768.5 172860.7	624.2 140403.6	474.2 106655.8
			40000	867.9 195222.1	705.0 158566.3	572.6 128793.2	435.0 97836.1
			60000	768.5 172860.7	624.2 140403.6	507.0 114040.8	385.1 86629.6
			100000	659.3 148297.9	535.5 120452.8	435.0 97836.1	330.4 74319.9
						50.0	100.0
320 12 7/16, 12 1/2	23168	4110 924000	10000	1481.4 333038.1	1203.2 270505.3	977.3 219714.0	742.4 166902.9
			30000	1065.4 239520.8	865.4 194547.3	702.9 158018.2	533.9 120036.5
			40000	977.3 219714.0	793.8 178459.5	644.8 144951.2	489.8 110110.3
			60000	865.4 194547.3	702.9 158018.2	570.9 128348.0	433.7 97497.9
			100000	742.4 166902.9	603.0 135564.5	489.8 110110.3	372.1 83643.8
						50.0	100.0
340 12 15/16, 13, 13 7/16, 13 1/2	23172	4250 955000	10000	1531.8 344211.4	1244.2 279580.7	1010.6 227085.4	767.7 172502.5
			30000	1101.7 247556.6	894.8 201074.3	726.8 163319.7	552.1 124063.7
			40000	1010.6 227085.4	820.8 184446.8	666.7 149814.3	506.5 113804.4
			60000	894.8 201074.3	726.8 163319.7	590.3 132654.0	448.4 100768.9
			100000	767.7 172502.5	623.5 140112.6	506.5 113804.4	384.7 86450.1
						50.0	100.0
360 13 15/16, 14	23176	4490 1009000	10000	1618.3 363674.7	1314.5 295389.5	1067.7 239925.8	
			30000	1163.9 261554.6	945.4 212443.9	767.9 172554.5	
			40000	1067.7 239925.8	867.2 194876.3	704.4 158285.4	
			60000	945.4 212443.9	767.9 172554.5	623.7 140154.9	
			100000	811.0 182256.5	658.7 148035.2	535.1 120239.5	
						50.0	100.0

(1) Speeds referenced here may be higher than speed ratings for seals. Please refer to the charts on page 57 – 59.

(2) For speeds greater than thermal reference speed, contact your Timken engineer.

Continued on next page.

LOAD RATINGS – *continued*

TABLE 28. TA - ALLOWABLE RADIAL LOAD (kN/LBS.) AT VARIOUS RPM⁽¹⁾ (CONTINUED)

Shaft Diameter	Bearing No.	C	L ₁₀ Life	Speed ⁽²⁾		
mm in.		kN lbs.		RPM		
380 14 15/16, 15	23180	4770 1072000	10000	1719.3 386381.8	1396.4 313833.0	1134.2 254906.3
			30000	1236.5 277885.6	1004.3 225708.5	815.7 183328.5
			40000	1134.2 254906.3	921.3 207044.0	748.3 168168.5
			60000	1004.3 225708.5	815.7 183328.5	662.6 148905.9
			100000	861.6 193636.3	699.8 157278.2	568.4 127746.0

⁽¹⁾ Speeds referenced here may be higher than speed ratings for seals. Please refer to the charts on page 57 – 59.

⁽²⁾ For speeds greater than thermal reference speed, contact your Timken engineer.

HOUSING LOADS

Because solid-block mounted bearings are made of cast steel, they are built to last with high allowable load limits in multiple orientations.

Refer to the table below for the maximum recommended housing load limit.

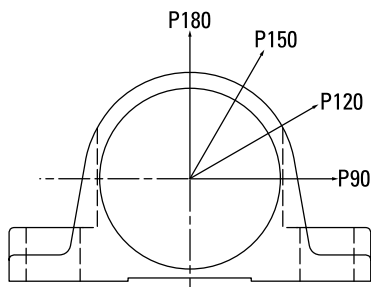

Fig. 32. Allowable housing loads.

CAUTION
Failure to follow these cautions could create a risk of injury.

Do not use damaged mounted bearings. The use of a damaged mounted bearing can result in equipment damage and/or injury.

TABLE 29. HOUSING CAPACITY CHART – QA/QM/TA/TAA SERIES

Bearing No.	Maximum Recommended Housing Loads	
	Two-Bolt	Four-Bolt
	kN lbs.	kN lbs.
22208	109 24400	N/A
22209	117 26400	N/A
22210	134 30200	N/A
22211	158 35400	158 35400
22212	174 39000	174 39000
22213	228 51300	235 52800
22214	N/A	N/A
22215	266 59700	267 60000
22216	278 62500	278 62500
22217	320 71900	320 71900
22218	404 90700	425 95500
22219	386 86800	433 97400
22220	512 115000	512 115000
22222	478 107400	677 152100
22224	494 110900	547 123000
22226	687 154300	837 188200
22228	745 167500	N/A
23230	1655 372000	1512 339700
23234	N/A	2198 494000

The values listed above are the maximum recommended housing load ratings; these loads may exceed bearing, mounting bolt and/or shaft capacities. When side load is present, stop bars or shear strips should be used against the machined housing foot ends. Housing maximum load listed is for all orientations shown in Fig. 32.

TABLE 30. HOUSING CAPACITY CHART – QV/DV/DAA SERIES

Bearing No.	Maximum Recommended Housing Loads	
	Two-Bolt	Four-Bolt
	kN lbs.	kN lbs.
22208	N/A	N/A
22209	117 26400	N/A
22210	134 30200	N/A
22211	158 35400	N/A
22212	174 39000	N/A
22213	228 51300	N/A
22214	231 52000	231 52000
22215	266 59700	N/A
22216	278 62500	278 62500
22217	320 71900	238 53500
22218	N/A	N/A
22219	394 88600	399 89700
22220	512 115000	423 95000
22222	677 152100	677 152100
22224	N/A	N/A
22226	837 188200	837 188200
22228	828 186000	576 129400

The values listed above are the maximum recommend housing load ratings; these loads may exceed bearing, mounting bolt and/or shaft capacities.
When side load is present, stop bars or shear strips should be used against the machined housing foot ends.

TABLE 31. HOUSING CAPACITY CHART – TAA SERIES (ONLY)

Bearing No.	Maximum Recommended Housing Loads	
	Two-Bolt	Four-Bolt
	kN lbs.	kN lbs.
23130	1388 312000	1388 312000
23132	N/A	520 116901
23134	N/A	610 137134
23136	N/A	705 158491
23138	N/A	815 183220
23140	N/A	830 186592
23144	N/A	970 218066
23148	N/A	1100 247291
23152	N/A	1220 274268
23156	N/A	1265 284385
23160	N/A	1535 345083
23164	N/A	1825 410278
23168	N/A	2055 461985
23172	N/A	2125 477721
23176	N/A	2245 504698
23180	N/A	2385 536172

The values listed above are the maximum recommend housing load ratings; these loads may exceed bearing, mounting bolt and/or shaft capacities.
When side load is present, stop bars or shear strips should be used against the machined housing foot ends.

NORMAL SPEED RATINGS FOR SEALS

TABLE 32. V-LOCK SERIES NORMAL SEAL SPEED RATINGS

Shaft Dia.	Bearing No.	Oil Lubrication			Grease Lubrication		
		M/N Seal ⁽¹⁾	T Seal	B/C/O Seal ⁽¹⁾	M/N Seal ⁽¹⁾	T Seal	B/C/O Seal ⁽¹⁾
mm in.		RPM	RPM	RPM	RPM	RPM	RPM
50 1 ¹⁵ / ₁₆ , 2	22211	2200	3800	1800	2200	3200	1600
55 2 ³ / ₁₆ , 2 ¹ / ₄	22212 22213	2000 1800	3500 3200	1650 1500	2000 1800	3000 2800	1550 1500
60, 65 2 ⁷ / ₁₆ , 2 ¹ / ₂	22214 22215	1700 1600	3050 2900	1400 1300	1700 1600	2600 2400	1400 1300
70, 75 2 ¹¹ / ₁₆ , 2 ³ / ₄ , 2 ¹⁵ / ₁₆ , 3	22216 22217	1500 1400	2650 2400	1200 1100	1500 1400	2200 2000	1150 1100
80, 85, 90 3 ³ / ₁₆ , 3 ¹ / ₄ , 3 ⁷ / ₁₆ , 3 ¹ / ₂	22219 22220	1300 1200	2200 2000	1000 900	1300 1200	1800 1600	950 900
100 3 ¹¹ / ₁₆ , 3 ³ / ₄ , 3 ¹⁵ / ₁₆ , 4	22222	900	1700	600	900	1200	600
110, 115 4 ⁷ / ₁₆ , 4 ¹ / ₂	22224 22226	700	1500	400	700	1000	400
125, 130 4 ¹⁵ / ₁₆ , 5	22228	650	1200	350	650	900	350

⁽¹⁾Bearings with contact seals will have higher operating temperatures than bearings with labyrinth seals.

TABLE 33. CL SERIES NORMAL SEAL SPEED RATINGS

Shaft Dia.	Bearing No.	Oil Lubrication			Grease Lubrication		
		M/N Seal ⁽¹⁾	T Seal	B/C/O Seal ⁽¹⁾	M/N Seal ⁽¹⁾	T Seal	B/C/O Seal ⁽¹⁾
mm in.		RPM	RPM	RPM	RPM	RPM	RPM
35 1 ⁷ / ₁₆ , 1 ¹ / ₂	22208	2700	4500	1950	2700	4000	1950
40, 45 1 ¹¹ / ₁₆ , 1 ³ / ₄	22209	2700	4500	1950	2700	4000	1950
50 1 ¹⁵ / ₁₆ , 2	22210	2400	4200	1800	2400	3550	1800
55 2 ³ / ₁₆ , 2 ¹ / ₄	22211	2200	3800	1600	2200	3200	1600
60, 65 2 ⁷ / ₁₆ , 2 ¹ / ₂	22213	1800	3200	1500	1800	2800	1500
70, 75 2 ¹¹ / ₁₆ , 2 ³ / ₄ , 2 ¹⁵ / ₁₆ , 3	22215	1600	2900	1300	1600	2400	1300
80, 85, 90 3 ³ / ₁₆ , 3 ¹ / ₄ , 3 ⁷ / ₁₆ , 3 ¹ / ₂	22218	1400	2400	1000	1400	2000	1000
100 3 ¹⁵ / ₁₆ , 4	22220	1200	2000	900	1200	1600	900
110, 115 4 ⁷ / ₁₆ , 4 ¹ / ₂	22222	900	1700	600	900	1200	600
125, 130 4 ¹⁵ / ₁₆ , 5	22226	700	1500	400	700	1000	400

⁽¹⁾Bearings with contact seals will have higher operating temperatures than bearings with labyrinth seals.

TABLE 34. EC SERIES NORMAL SEAL SPEED RATINGS

Shaft Dia. mm in.	Bearing No.	Oil Lubrication			Grease Lubrication		
		M/N Seal ⁽¹⁾ RPM	T Seal RPM	B/C/O Seal ⁽¹⁾ RPM	M/N Seal ⁽¹⁾ RPM	T Seal RPM	B/C/O Seal ⁽¹⁾ RPM
35 1 7/16, 1 1/2	22208	2700	4500	1950	2700	4000	1950
40, 45 1 11/16, 1 3/4	22209	2700	4500	1950	2700	4000	1950
50 1 15/16, 2	22210	2400	4200	1800	2400	3550	1800
55 2 3/16, 2 1/4	22211	2200	3800	1600	2200	3200	1600
60, 65 2 7/16, 2 1/2	22213	1800	3200	1500	1800	2800	1500
70, 75 2 11/16, 2 3/4, 2 15/16, 3	22215	1600	2900	1300	1600	2400	1300
80, 85, 90 3 3/16, 3 1/4, 3 7/16, 3 1/2	22218	1400	2400	1000	1400	2000	1000
100 3 11/16, 3 3/4, 3 15/16, 4	22220	1200	2000	900	1200	1600	900
110, 115 4 7/16, 4 1/2	22222	900	1700	600	900	1200	600
125, 130 4 15/16, 5	22226	700	1500	400	700	1000	400
140, 150 5 7/16, 5 1/2, 5 15/16, 6	23230	650	950	350	600	800	350
170, 180 6 7/16, 6 1/2, 6 15/16, 7	23234	600	900	350	600	800	350

⁽¹⁾Bearings with contact seals will have higher operating temperatures than bearings with labyrinth seals.

NORMAL SPEED RATINGS FOR SEALS – continued**TABLE 35. TA/DV TAA/DVV SERIES NORMAL SEAL SPEED RATINGS**

Shaft Dia.	Bearing No.	Oil Lubrication			Grease Lubrication		
		M/N Seal ⁽¹⁾	T Seal	B/C/O Seal ⁽¹⁾	M/N Seal ⁽¹⁾	T Seal	B/C/O Seal ⁽¹⁾
mm in.		RPM	RPM	RPM	RPM	RPM	RPM
40 1 7/16, 1 1/2	22209	2700	4500	1950	2700	4000	1950
45 1 11/16, 1 3/4	22210	2400	4200	1800	2400	3550	1800
50 1 15/16, 2	22211	2200	3800	1800	2200	3200	1600
55 –	22212	2000	3500	1650	2000	3000	1550
60 2 3/16, 2 1/4	22213	1800	3200	1500	1800	2800	1500
65 2 7/16, 2 1/2	22215	1600	2900	1300	1600	2400	1300
70 2 11/16, 2 3/4	22216	1500	2650	1200	1500	2200	1150
75 2 15/16, 3	22217	1400	2400	1100	1400	2000	1100
80 3 3/16, 3 1/4	22218	1400	2400	1000	1400	2000	1000
85 –	22219	1300	2200	1000	1300	1800	950
90 3 7/16, 3 1/2	22220	1200	2000	900	1200	1600	900
100 3 15/16, 4	22222	900	1700	600	900	1200	600
110 4 3/16, 4 1/4	22224	800	1600	500	800	1100	500
115 4 7/16, 4 1/2	22226	700	1500	400	700	1000	400
125 4 15/16, 5	22228	650	1200	350	650	900	350
135 5 3/16, 5 1/4	23130	-	-	-	-	875	350
140 5 3/8, 5 7/16, 5 1/2	23132	-	-	-	-	750	500 ⁽²⁾
150 5 13/16, 5 7/8, 5 15/16, 6	23134	-	-	-	-	700	470 ⁽²⁾
160 6 5/16, 6 3/8, 6 7/16, 6 1/2	23136	-	-	-	-	650	430 ⁽²⁾
170 6 13/16, 6 7/8, 6 15/16, 7	23138	-	-	-	-	600	400 ⁽²⁾
180 7 1/8, 7 3/16, 7 1/4	23140	-	-	-	-	600	400 ⁽²⁾
200 7 13/16, 7 7/8, 7 15/16, 8	23144	-	-	-	-	500	330 ⁽²⁾
220 8 7/16, 8 1/2, 8 15/16, 9	23148	-	-	-	-	470	310 ⁽²⁾
240 9 7/16, 9 1/2	23152	-	-	-	-	380	250 ⁽²⁾
260 9 15/16, 10, 10 7/16, 10 1/2	23156	-	-	-	-	360	240 ⁽²⁾
280 10 15/16, 11	23160	-	-	-	-	320	210 ⁽²⁾
300 11 7/16, 11 1/2, 11 15/16, 12	23164	-	-	-	-	290	190 ⁽²⁾
320 12 7/16, 12 1/2	23168	-	-	-	-	270	180 ⁽²⁾
340 12 15/16, 13, 13 7/16, 13 1/2	23172	-	-	-	-	250	170 ⁽²⁾
360 13 15/16, 14	23176	-	-	-	-	240	160 ⁽²⁾
380 14 15/16, 15	23180	-	-	-	-	230	150 ⁽²⁾

⁽¹⁾Bearings with contact seals will have higher operating temperatures than bearings with labyrinth seals.⁽²⁾Only available in O seal.

SEAL MATERIAL CHEMICAL COMPATIBILITY

A - Little to no effect B - Minor to moderate effect C - Severe effect to destruction N - No data – test prior to use.	Urethane	Nitrile Rubber	Viton	DuPont Teflon
Acetaldehyde	C	C	C	A
Acetamide	N	A	B	A
Acetic Acid	C	B	B	A
Acetic Anhydride	C	C	C	A
Acetone	C	C	C	A
Acetyl Bromide	C	N	N	N
Acetyl Chloride	C	C	A	A
Acetylene	C	A	A	A
Adipic Acid	A	A	N	A
Aero Shell Grease	B	A-B	A	A
Aero Lubriplate	A	A	A	A
Aero Safe 2300	N	C	C	A
Aerozine 50	N	C	C	A
Aluminum Acetate	N	A	C	A
Aluminum Bromide	N	A	A	A
Aluminum Chloride	B	A	A	A
Aluminum Sulfate	B	A	A	A
Ammonia	B	B	C	A
Ammonium Carbonate	B	C	N	A
Ammonium Chloride	N	A	A	A
Ammonium Hydroxide	B	C	A	A
Ammonium Nitrate	B	A	N	A
Ammonium Persulfate	B	C	N	A
Ammonium Sulfate	B	A	C	A
Ammonium Sulfide	B	A	C	A
Ammonium Thiocyanate	B	N	N	A
Ammonium Acetate	C	N	N	A
Amyl Acetate	C	C	C	A
Amyl Alcohol	C	B	C	A
Aniline	C	C	C	A
Aniline Hydrochloride	C	B	B	B
Animal Fats and Oils	B	A	A	A
Antimony Salts	B	N	N	A
Aqua Regia	C	C	B	A
Arsenic Salts	B	N	N	A
ASTM Oil #1	A	A	A	A
ASTM Oil #2	B	A	A	A
ASTM Oil #3	B	A	A	A
ASTM Reference Fuel A	A	A	A	A
ASTM Reference Fuel B	B	B	A	A
Atlantic Oil	A	A	A	A
Barium Carbonate	B	A	A	A
Barium Hydroxide	A	A	A	A
Beer	A	A	A	A
Benzaldehyde	B	C	C	A
Benzene	C	C	B	A
Benzoic Acid	B	C	A	A
Black Sulphate Liquors	N	B	A	A

A - Little to no effect B - Minor to moderate effect C - Severe effect to destruction N - No data – test prior to use.	Urethane	Nitrile Rubber	Viton	DuPont Teflon
Bleach Solutions	N	C	A	B
Boric Acid	A	A	A	A
Brake Fluid	N	C	C	N
Bromine	B	C	A	C
Bunker Oil	A	A	A	A
Butane	A	A	A	A
Butyl Acetate	C	C	C	A
Butyl Alcohol	B	A	A	A
Calcium Carbonate	B	A	A	A
Calcium Chloride	A	A	A	A
Calcium Hydroxide	A	A	A	A
Calcium Nitrate	B	A	A	A
Calcium Sulfate	B	B	B	A
Carbon Dioxide	A	A	A	A
Carbon Disulfide	B	C	A	A
Carbon Monoxide	A	A	A	A
Carbon Tetrachloride	C	C	A	A
Chlorine	N	C	A	B
Chloroacetic Acid	C	C	C	N
Chloroform	C	N	N	B
Chromic Acid	C	C	A	B
Chromium Potassium Sulfate	A	N	N	N
Citric Acid	B	A	A	A
Corn Oil	A	A	A	A
Cottonseed Oil	A	A	A	A
Cresol	C	C	A	A
Crude Oil	B	B	A	A
Cupric Chloride	A	B	B	A
Cupric Nitrate	B	N	N	A
Cupric Sulfate	B	B	B	A
Cutting Oil	B	A	A	A
Cyclohexane	B	A	A	A
Cyclohexanone	C	C	A	A
Dibutyl Phthalate	C	C	C	B
Dichlorobenzene	C	N	N	B
Diesel Fuel	B	A	A	A
Diester Oil	B	B	A	A
Dimethyl Acetamide	C	N	N	A
Dimethyl Formamide	C	B	C	A
Dodecyl Mercaptan	B	N	N	N
DTE Oil	B	A	N	N
Dubutyl Ether	B	C	C	N
EP Lubes	A	A	A	A
Esso #90 Lube Oil	A	A	A	A
Ether	B	N	N	A
Ethyl Acetate	C	C	C	A
Ethyl Alcohol (Ethanol)	C	A	C	A
Formic Acid	C	B	C	A

DISCLAIMER: Every reasonable effort has been made to ensure the accuracy of the information in this writing, but no liability is accepted for errors, omissions or for any other reason.

Continued on next page.

SEAL AND COVER OPTIONS • SEAL MATERIAL CHEMICAL COMPATIBILITY

Continued from previous page.

A - Little to no effect B - Minor to moderate effect C - Severe effect to destruction N - No data – test prior to use.	Urethane	Nitrile Rubber	Viton	DuPont Teflon	A - Little to no effect B - Minor to moderate effect C - Severe effect to destruction N - No data – test prior to use.	Urethane	Nitrile Rubber	Viton	DuPont Teflon
Freon, 12 or 113	A	A	B	A	Palmitic Acid	A	A	A	A
Fuel Oil	B	A	A	A	Paint Thinner	B	C	B	A
Gasoline	B	B	A	A	Peanut Oil	A	A	A	A
Glucose	A	A	A	A	Perchloric Acid	C	C	A	A
Glue	N	A	A	A	Perchloroethylene	C	B	A	A
Glycerin	A	A	A	A	Petroleum	B	A	A	A
Heptane	A	N	N	A	Phenol (Carbolic Acid)	C	C	A	A
Hexane	A	A	A	A	Phosphoric Acid	C	C	A	A
Hydrazine	C	B	C	B	Potassium Cyanide	A	A	A	A
Hydrobromic Acid	B	C	A	A	Potassium Salts	B	A	A	A
Hydrocarbon Oil	A	A	A	A	Propane	B	A	A	A
Hydrochloric Acid	B	C	B	A	Propyl Alcohol	B	A	A	A
Hydrofluoric Acid	B	C	C	A	Propylene Glycol	B	N	N	A
Hydrogen	A	A	A	A	Pydraul Oil	C	C	A	A
Hydrogen Peroxide	B	C	A	B	SAE #10 Oil	A	A	A	A
Hydrogen Sulfide	C	C	C	A	Seawater	A	A	A	A
Hydrologic Acid	B	N	N	N	Silicic Acid	B	N	N	A
Iodine	A	B	A	A	Silver Nitrate	B	B	A	A
Isobutyl Alcohol	N	B	A	A	Skydrol Oil	C	C	C	A
Isopropyl Chloride	N	C	A	A	Soap	B	A	A	A
Isopropyl Ether	B	B	C	N	Sodium Acetate	A	B	C	A
Isopropyl Alcohol (Propanol)	B	A	A	N	Sodium Bicarbonate	B	A	A	A
JP4 Oil	B	A	A	A	Sodium Borate	B	A	A	A
JP5 and 6 Oil	C	A	A	A	Sodium Carbonate	B	A	A	A
Kerosene	B	A	A	A	Sodium Chloride	B	A	A	A
Lactic Acid	B	B	A	A	Sodium Cyanide	B	A	A	A
Lead Acetate	B	B	C	A	Sodium Hydrosulfite	B	N	N	A
Linseed Oil	B	A	A	A	Sodium Hydroxide	B	B	B	A
Liquefied Petroleum Gas	A	A	A	N	Sodium Hypochlorite	C	B	A	A
Lubrication Oil	B	A	A	A	Sodium Nitrate	B	B	N	A
Lye	N	B	B	A	Sodium Silicate	A	A	A	A
Magnesium Chloride	N	A	A	A	Sodium Sulfate	B	A	A	A
Magnesium Hydroxide	A	B	A	A	Sodium Sulfide	B	A	A	A
Magnesium Salts	B	A	A	A	Steam	C	C	C	A
Maleic Acid	C	C	A	A	Styrene	B	C	B	A
Mercury	B	A	A	A	Sulfur Dioxide	B	C	A	A
Methyl Alcohol (Methanol)	A	C	A	N	Sulfuric Acid	C	C	A	A
Methyl Ethyl Ketone	C	C	C	A	Tannic Acid	A	A	A	A
Methylene Chloride	C	C	B	A	Tartaric Acid	A	A	A	A
MIL-D-5606 Oil	C	A	A	A	Toluene	C	N	N	A
MIL-L7808 Oil	B	B	A	A	Transformer Oil	B	N	N	A
Mineral Oil	A	A	A	A	Turpentine	C	A	A	A
Mineral Spirits	N	B	A	A	Urea	B	N	N	A
Naphthalene	B	C	A	A	Varnish	B	B	A	A
Natural Gas	B	A	A	A	Water	B	A	A	A
Nickel Salts	C	A	A	A					
Oxygen	A	B	A	A					
Ozone	A	C	A	A					

DISCLAIMER: Every reasonable effort has been made to ensure the accuracy of the information in this writing, but no liability is accepted for errors, omissions or for any other reason.

NORMAL SPEED RATINGS FOR SEALS

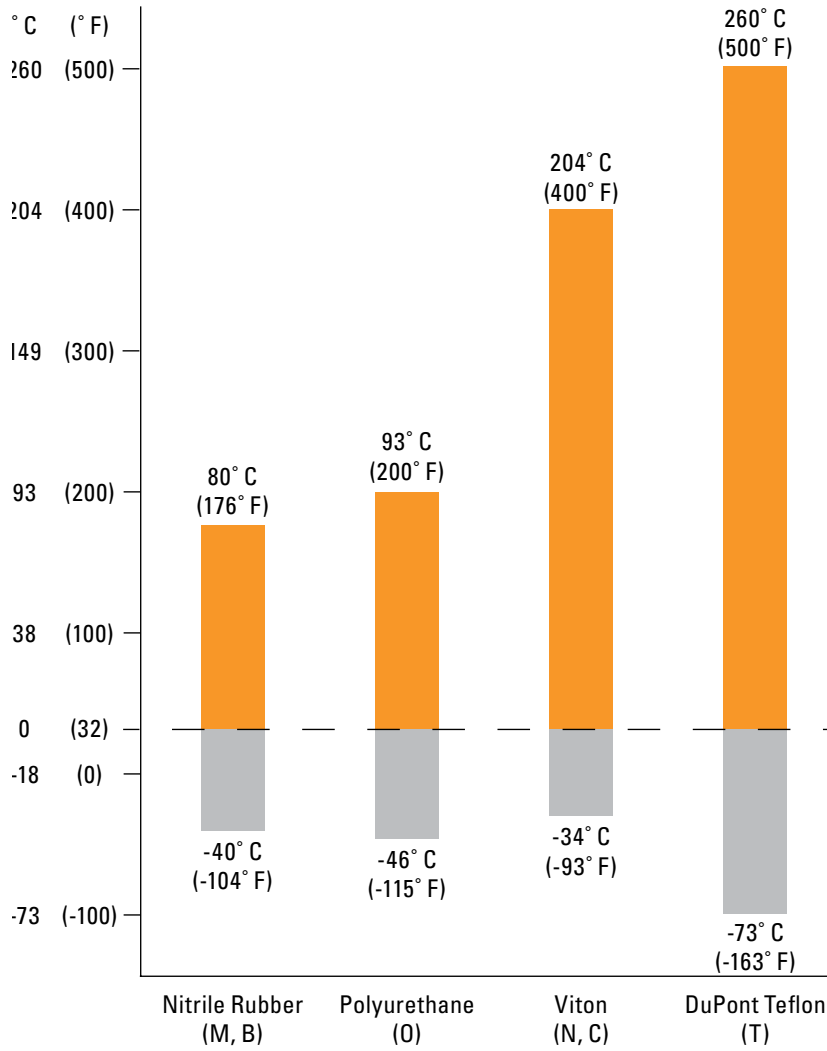

Fig. 33. Seal temperature ratings based on analytics.

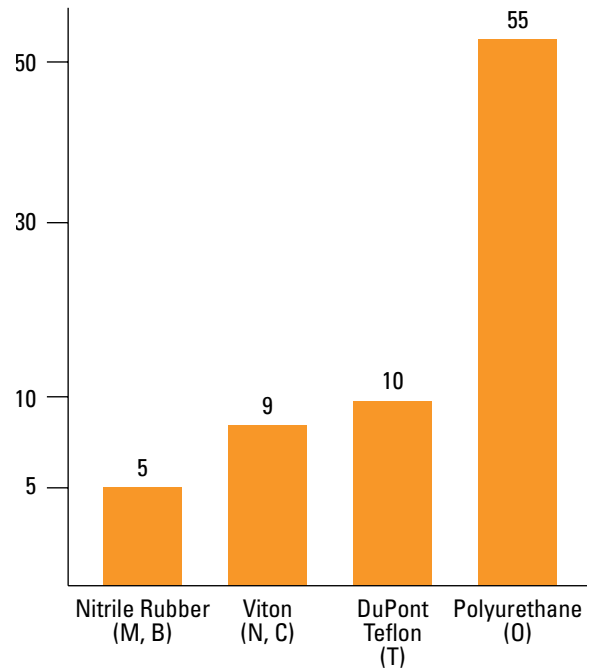

Fig. 34. Relative abrasion resistance ratings.

INTERNAL RADIAL CLEARANCES

TABLE 36. V-LOCK SERIES (TAPERED BORE, C3)

Shaft Dia.	Bearing No.	Clearance		Minimum Permissible RIC After Installation
		Min.	Max.	
mm in.		mm in.	mm in.	mm in.
50 1 15/16, 2	22211	0.075 0.0030	0.095 0.0037	0.038 0.0015
55 2 3/16, 2 1/4	22212	0.075 0.0030	0.095 0.0037	0.038 0.0015
55 2 3/16, 2 1/4	22213	0.075 0.0030	0.095 0.0037	0.038 0.0015
60, 65 2 7/16, 2 1/2	22214	0.094 0.0037	0.119 0.0047	0.043 0.0017
60, 65 2 7/16, 2 1/2	22215	0.094 0.0037	0.119 0.0047	0.043 0.0017
70, 75 2 11/16, 2 3/4, 2 15/16, 3	22216	0.094 0.0037	0.119 0.0047	0.049 0.0017
70, 75 2 11/16, 2 3/4, 2 15/16, 3	22217	0.109 0.0043	0.140 0.0055	0.051 0.0020
80, 85, 90 3 3/16, 3 1/4, 3 7/16, 3 1/2	22219	0.109 0.0043	0.140 0.0055	0.051 0.0020
80, 85, 90 3 3/16, 3 1/4, 3 7/16, 3 1/2	22220	0.109 0.0043	0.140 0.0055	0.051 0.0020
100 3 11/16, 3 3/4, 3 15/16, 4	22222	0.135 0.0053	0.170 0.0067	0.064 0.0025
110 —	22224	0.135 0.0053	0.170 0.0067	0.064 0.0025
110, 115 4 7/16, 4 1/2	22226	0.160 0.0063	0.201 0.0079	0.076 0.0030
125, 130 4 15/16, 5	22228	0.160 0.0063	0.201 0.0079	0.076 0.0030

TABLE 37. CL SERIES (STRAIGHT BORE, C NORMAL)

Shaft Dia.	Bearing No.	Clearance	
		Min.	Max.
mm in.		mm in.	mm in.
35 1 7/16, 1 1/2	22208	0.030 0.0012	0.045 0.0018
40, 45 1 11/16, 1 3/4	22209	0.035 0.0014	0.055 0.0022
50 1 15/16, 2	22210	0.040 0.0016	0.065 0.0026
55 2 3/16, 2 1/4	22211	0.040 0.0016	0.065 0.0026
60, 65 2 7/16, 2 1/2	22213	0.040 0.0016	0.065 0.0026
70, 75 2 11/16, 2 3/4, 2 15/16, 3	22215	0.050 0.002	0.080 0.0031
80, 85, 90 3 3/16, 3 1/4, 3 7/16, 3 1/2	22218	0.060 0.0024	0.100 0.0039
100 3 15/16, 4	22220	0.075 0.003	0.120 0.0047
110, 115 4 7/16, 4 1/2	22222	0.075 0.003	0.120 0.0047
125, 130 4 15/16, 5	22226	0.095 0.0037	0.145 0.0057

TABLE 38. EC SERIES (STRAIGHT BORE, C NORMAL)

Shaft Dia.	Bearing No.	Clearance	
		Min.	Max.
mm in.		mm in.	mm in.
35 1 7/16, 1 1/2	22208	0.030 0.0012	0.045 0.0018
40, 45 1 11/16, 1 3/4	22209	0.0350 0.0014	0.055 0.0022
50 1 15/16, 2	22210	0.040 0.0016	0.065 0.0026
55 2 3/16, 2 1/4	22211	0.040 0.0016	0.065 0.0026
60, 65 2 7/16, 2 1/2	22213	0.040 0.0016	0.065 0.0026
70, 75 2 11/16, 2 3/4, 2 15/16, 3	22215	0.050 0.002	0.080 0.0031
80, 85, 90 3 3/16, 3 1/4, 3 7/16, 3 1/2	22218	0.060 0.0024	0.100 0.0039

Shaft Dia.	Bearing No.	Clearance	
		Min.	Max.
mm in.		mm in.	mm in.
100 3 11/16, 3 3/4, 3 15/16, 4	22220	0.075 0.003	0.120 0.0047
110, 115 4 7/16, 4 1/2	22222	0.075 0.003	0.120 0.0047
125, 130 4 15/16, 5	22226	0.095 0.0037	0.145 0.0057
140, 150 5 7/16, 5 1/2, 5 15/16, 6	23230	0.110 0.0043	0.170 0.0067
170, 180 6 7/16, 6 1/2, 6 15/16, 7	23234	0.120 0.0047	0.180 0.0071

INTERNAL RADIAL CLEARANCES – continued

TABLE 39. TA (TAPERED BORE, C3)

Shaft Dia.	Bearing No.	Clearance Prior To Installation		Recommended Reduction Of Internal Radial Clearance		Recommended Axial Movement Of Adapter Sleeve		Minimum Internal Radial Clearance
		Min.	Max.	Min.	Max.	Min.	Max.	
mm in.		mm in.	mm in.	mm in.	mm in.	mm in.	mm in.	mm in.
40 1 7/16, 1 1/2	22209	0.061 0.0024	0.079 0.0031	0.025 0.0010	0.030 0.0012	0.381 0.015	0.457 0.018	0.030 0.0012
45 1 11/16, 1 3/4	22210	0.061 0.0024	0.079 0.0031	0.025 0.0010	0.030 0.0012	0.381 0.015	0.457 0.018	0.030 0.0012
50 1 15/16, 2	22211	0.076 0.0030	0.094 0.0037	0.030 0.0012	0.038 0.0015	0.457 0.018	0.559 0.022	0.038 0.0015
55 –	22212	0.076 0.0030	0.094 0.0037	0.030 0.0012	0.038 0.0015	0.457 0.018	0.559 0.022	0.038 0.0015
60 2 3/16, 2 1/4	22213	0.076 0.0030	0.094 0.0037	0.030 0.0012	0.038 0.0015	0.457 0.018	0.559 0.022	0.038 0.0015
65 2 7/16, 2 1/2	22215	0.094 0.0037	0.119 0.0047	0.038 0.0015	0.051 0.0020	0.559 0.022	0.762 0.030	0.043 0.0017
70 2 11/16, 2 3/4	22216	0.094 0.0037	0.119 0.0047	0.038 0.0015	0.051 0.0020	0.559 0.022	0.762 0.030	0.043 0.0017
75 2 15/16, 3	22217	0.109 0.0043	0.140 0.0055	0.046 0.0018	0.064 0.0025	0.686 0.027	0.965 0.038	0.051 0.0020
80 3 3/16, 3 1/4	22218	0.109 0.0043	0.140 0.0055	0.046 0.0018	0.064 0.0025	0.686 0.027	0.965 0.038	0.051 0.0020
85 –	22219	0.109 0.0043	0.140 0.0055	0.046 0.0018	0.064 0.0025	0.686 0.027	0.965 0.038	0.051 0.0020
90 3 7/16, 3 1/2	22220	0.109 0.0043	0.140 0.0055	0.046 0.0018	0.064 0.0025	0.686 0.027	0.965 0.038	0.051 0.0020
100 3 15/16, 4	22222	0.135 0.0053	0.170 0.0067	0.051 0.0020	0.071 0.0028	0.762 0.030	1.067 0.042	0.064 0.0025
110 4 3/16, 4 1/4	22224	0.135 0.0053	0.170 0.0067	0.051 0.0020	0.071 0.0028	0.762 0.030	1.067 0.042	0.064 0.0025
115 4 7/16, 4 1/2	22226	0.160 0.0063	0.201 0.0079	0.064 0.0025	0.089 0.0035	0.889 0.035	1.270 0.050	0.076 0.0030
125 4 15/16, 5	22228	0.160 0.0063	0.201 0.0079	0.064 0.0025	0.089 0.0035	0.889 0.035	1.270 0.050	0.076 0.0030
135 5 3/16, 5 1/4	23130	0.180 0.0071	0.231 0.0091	0.076 0.0030	0.102 0.0040	1.140 0.0449	1.520 0.0598	0.075 0.0030
140 5 3/8, 5 7/16, 5 1/2	23132	0.180 0.0071	0.231 0.0091	0.076 0.0030	0.102 0.0040	1.140 0.0449	1.520 0.0598	0.075 0.0030
150 5 13/16, 5 7/8, 5 15/16, 6	23134	0.201 0.0079	0.259 0.0102	0.076 0.0030	0.114 0.0045	1.255 0.04939	1.816 0.07150	0.089 0.0035
160 6 5/16, 6 3/8, 6 7/16, 6 1/2	23136	0.201 0.0079	0.259 0.0102	0.076 0.0030	0.114 0.0045	1.255 0.04939	1.816 0.07150	0.089 0.0035
170 6 13/16, 6 7/8, 6 15/16, 7	23138	0.221 0.0087	0.290 0.0114	0.089 0.0035	0.127 0.0050	1.539 0.06061	2.090 0.08228	0.102 0.0040
180 7 1/8, 7 3/16, 7 1/4	23140	0.221 0.0087	0.290 0.0114	0.089 0.0035	0.127 0.0050	1.539 0.06061	2.090 0.08228	0.102 0.0040
200 7 13/16, 7 7/8, 7 15/16, 8	23144	0.249 0.0098	0.320 0.0126	0.102 0.0040	0.140 0.0055	1.671 0.06578	2.232 0.08789	0.114 0.0045
220 8 7/16, 8 1/2, 8 15/16, 9	23148	0.269 0.0106	0.351 0.0138	0.114 0.0045	0.152 0.0060	1.959 0.07711	2.520 0.09922	0.114 0.0045
240 9 7/16, 9 1/2	23152	0.300 0.0118	0.391 0.0154	0.114 0.0045	0.165 0.0065	1.959 0.07711	2.794 0.11000	0.140 0.0055
260 9 15/16, 10, 10 7/16, 10 1/2	23156	0.300 0.0118	0.391 0.0154	0.114 0.0045	0.165 0.0065	1.959 0.07711	2.794 0.11000	0.140 0.0055
280 10 15/16, 11	23160	0.330 0.0130	0.429 0.0169	0.127 0.0050	0.178 0.0070	2.090 0.08228	2.936 0.11561	0.152 0.0060
300 11 7/16, 11 1/2, 11 15/16, 12	23164	0.361 0.0142	0.470 0.0185	0.140 0.0055	0.191 0.0075	2.232 0.08789	3.068 0.12078	0.165 0.0065
320 12 7/16, 12 1/2	23168	0.361 0.0142	0.470 0.0185	0.140 0.0055	0.191 0.0075	2.232 0.08789	3.068 0.12078	0.165 0.0065
340 12 15/16, 13, 13 7/16, 13 1/2	23172	0.399 0.0157	0.521 0.0205	0.152 0.0060	0.203 0.0080	2.520 0.09922	3.356 0.13211	0.191 0.0075
360 13 15/16, 14	23176	0.399 0.0157	0.521 0.0205	0.152 0.0060	0.203 0.0080	2.520 0.09922	3.356 0.13211	0.191 0.0075
380 14 15/16, 15	23180	0.399 0.0157	0.521 0.0205	0.152 0.0060	0.203 0.0080	2.520 0.09922	3.356 0.13211	0.191 0.0075

SHAFTING

When installing and using mounted bearings, all shafting should be straight, clean, free from burrs and within the recommended shaft tolerances in tables 40 and 41. For applications that involve high speed or extreme vibration conditions, we recommend that all shafting be machined to one-half the recommended tolerances below.

SHAFT EXPANSION

Steel expands or contracts 0.0000113 millimeters per millimeter for each degree Celsius (0.0000063 inches per inch for each degree Fahrenheit) relative temperature increase or decrease respectively. Expansion bearings are used to accommodate thermal expansion of steel. Where the shafting and the framework on which the bearings and shafting are mounted are made from

steel, the relative difference in expansion between the shaft and the framework will be minimal. In these conditions, fixed bearings can be used on both ends of the shaft. However, if there is a difference in material between the shaft and the framework, or if the application involves different temperatures from the shaft to the frame, then only one fixed bearing should be used on each shaft. All other bearings on the same shaft should be converted to floating to accommodate thermal expansion of the shaft.

**TABLE 40. V-LOCK, CL AND EC SERIES –
RECOMMENDED SHAFT TOLERANCES**

Shaft Dia.	Shaft Tolerance
mm in.	mm in.
35 1 ⁷ / ₁₆ , 1 ¹ / ₂	+0.00/-0.025 +0.00/-0.0010
40, 45 1 ¹ / ₁₆ , 1 ³ / ₄	+0.00/-0.038 + 0.00/-0.0015
50 1 ¹⁵ / ₁₆ , 2	+0.00/-0.038 + 0.00/-0.0015
55 2 ³ / ₁₆ , 2 ¹ / ₄	+0.00/-0.038 + 0.00/-0.0015
60, 65 2 ⁷ / ₁₆ , 2 ¹ / ₂	+0.00/-0.038 + 0.00/-0.0015
70, 75 2 ¹ / ₁₆ , 2 ³ / ₄ , 2 ¹⁵ / ₁₆ , 3	+0.00/-0.051 + 0.00/-0.0020
80, 85, 90 3 ³ / ₁₆ , 3 ¹ / ₄ , 3 ⁷ / ₁₆ , 3 ¹ / ₂	+0.00/-0.076 + 0.00/-0.0030
100 3 ¹ / ₁₆ , 3 ³ / ₄ , 3 ¹⁵ / ₁₆ , 4	+0.00/-0.076 + 0.00/-0.0030
110, 115 4 ⁷ / ₁₆ , 4 ¹ / ₂	+0.00/-0.127 + 0.00/-0.0050
125, 130 4 ¹⁵ / ₁₆ , 5	+0.00/-0.127 + 0.00/-0.0050
140, 150 5 ⁷ / ₁₆ , 5 ¹ / ₂ , 5 ¹⁵ / ₁₆ , 6	+0.00/-0.127 + 0.00/-0.0050
170, 180 6 ⁷ / ₁₆ , 6 ¹ / ₂ , 6 ¹⁵ / ₁₆ , 7	+0.00/-0.127 + 0.00/-0.0050

SHAFT TOLERANCES

TABLE 41. TA/DV TAA/DVV RECOMMENDED SHAFT TOLERANCES

Shaft Dia.		Shaft Tolerance		Shaft Dia.		Shaft Tolerance	
mm	in.	mm	in.	mm	in.	mm	in.
40		+0.00/-0.025		140		+0.00/-0.127	
1 7/16, 1 1/2		+0.00/-0.0010		5 3/8, 5 7/16, 5 1/2		+0.00/-0.0050	
45		+0.00/-0.051		150		+0.00/-0.127	
1 11/16, 1 3/4		+0.00/-0.0020		5 13/16, 5 7/8, 5 15/16, 6		+0.00/-0.0050	
50		+0.00/-0.076		160		+0.00/-0.127	
1 15/16, 2		+0.00/-0.0030		6 5/16, 6 3/8, 6 7/16, 6 1/2		+0.00/-0.0050	
55		+0.00/-0.076		170		+0.00/-0.127	
—		—		6 13/16, 6 7/8, 6 15/16, 7		+0.00/-0.0050	
60		+0.00/-0.076		180		+0.00/-0.127	
2 3/16, 2 1/4		+0.00/-0.0030		7 1/8, 7 3/16, 7 1/4		+0.00/-0.0050	
65		+0.00/-0.089		200		+0.00/-0.127	
2 7/16, 2 1/2		+0.00/-0.0035		7 13/16, 7 7/8, 7 15/16, 8		+0.00/-0.0050	
70		+0.00/-0.102		220		+0.00/-0.152	
2 11/16, 2 3/4		+0.00/-0.0040		8 7/16, 8 1/2, 8 15/16, 9		+0.00/-0.0060	
75		+0.00/-0.102		240		+0.00/-0.152	
2 15/16, 3		+0.00/-0.0040		9 7/16, 9 1/2		+0.00/-0.0060	
80		+0.00/-0.102		260		+0.00/-0.152	
3 3/16, 3 1/4		+0.00/-0.0040		9 15/16, 10, 10 7/16, 10 1/2		+0.00/-0.0060	
85		+0.00/-0.102		280		+0.00/-0.178	
—		—		10 15/16, 11		+0.00/-0.0070	
90		+0.00/-0.102		300		+0.00/-0.178	
3 7/16, 3 1/2		+0.00/-0.0040		11 7/16, 11 1/2, 11 15/16, 12		+0.00/-0.0070	
100		+0.00/-0.102		320		+0.00/-0.203	
3 15/16, 4		+0.00/-0.0040		12 7/16, 12 1/2		+0.00/-0.0080	
110		+0.00/-0.102		340		+0.00/-0.203	
4 3/16, 4 1/4		+0.00/-0.0040		12 15/16, 13, 13 7/16, 13 1/2		+0.00/-0.0080	
115		+0.00/-0.102		360		+0.00/-0.203	
4 7/16, 4 1/2		+0.00/-0.0040		13 15/16, 14		+0.00/-0.0080	
125		+0.00/-0.127		380		+0.00/-0.203	
4 15/16, 5		+0.00/-0.0050		14 15/16, 15		+0.00/-0.0080	
135		+0.00/-0.127					
5 3/16, 5 1/4		+0.00/-0.0050					

CONVERSION FROM FIXED TO FLOATING

Mounted bearings are easily converted from fixed to floating in the field (see the appropriate installation guide in this catalog for instructions). The following table will help you determine the amount of float for each bearing based on the number of revolutions the external housing nut is backed out.

TABLE 42. AMOUNT OF FLOAT PER ONE ROTATION OF EXTERNAL HOUSING NUT

Bearing Number	Float	Bearing Number	Float
	mm in.		mm in.
22208	1.270 0.050	23234	2.108 0.083
22209	1.270 0.050	23130	2.108 0.083
22210	1.270 0.050	23132	2.108 0.083
22211	1.270 0.050	23134	2.108 0.083
22212	1.270 0.050	23136	2.108 0.083
22213	2.108 0.083	23138	2.108 0.083
22214	2.108 0.083	23140	2.108 0.083
22215	2.108 0.083	23144	2.108 0.083
22216	2.108 0.083	23148	2.108 0.083
22217	2.108 0.083	23152	2.108 0.083
22218	2.108 0.083	23156	2.108 0.083
22219	2.108 0.083	23160	2.108 0.083
22220	2.108 0.083	23164	2.108 0.083
22222	2.108 0.083	23168	2.108 0.083
22224	2.108 0.083	23172	2.108 0.083
22226	2.108 0.083	23176	2.108 0.083
22228	2.108 0.083	23180	2.108 0.083
23230	2.108 0.083		

LUBRICATION

Timken is dedicated to using the highest quality components in everything we do. This is why we use premium industrial grease in solid-block mounted spherical roller bearings. The lithium-complex extreme-pressure grease combines the benefits of wide operating temperatures and broad compatibility. This grease offers excellent thermal stability through temperatures ranging from -34° C to 177° C (-30° F to 350° F). When dealing with temperatures above 149° C (300° F), consult your Timken engineer for optional grease recommendations. Application-specific lubrication options are also available ranging from Timken Food Safe Grease (aluminum-complex) to Timken Mill grease (calcium-sulfonate) along with many others.

MISALIGNMENT

All mounted spherical roller bearings utilize self-aligning double-row spherical roller bearings. Because of this, the mounted bearing accommodates angular misalignment up to 1.5 degrees. The life performance of our mounted bearing is not reduced while under misalignment conditions within these guidelines. It will accept both radial and thrust loads under static, oscillatory or dynamic load conditions.

TABLE 43. MISALIGNMENT SCALE AT 1.5 DEGREES

A	B
m ft.	mm in.
0.305 1	7.981 0.314
1.524 5	39.905 1.570

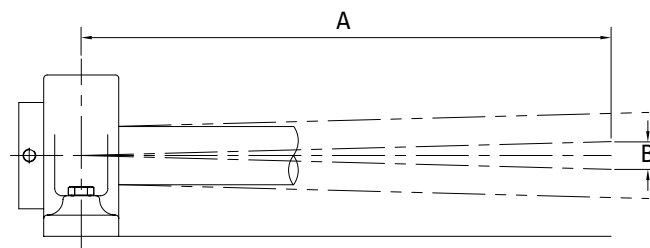

Fig. 35. Misalignment.

INSTALLATION GUIDES

V-LOCK SERIES

Timken® solid-block mounted V-Lock bearings are easy to install and remove because of their unique adapters.

Please complete the following steps to install and/or remove Timken steel mounted V-Lock bearings. Refer to fig. 36.

- Ensure that the shaft is clean, free from nicks and burrs, straight and of proper diameter. See table 45 for recommended shaft tolerances. The mounted bearing should not be mounted on a worn section of the shaft.
- If using an open-end cover, slide the open-end cover/seal combination into position on the shaft.
- Remove the wedge assembly from the sleeve by unscrewing the wedge nut. See fig. 36.
- Clean oil off of the sleeve and wedge.
- Apply a thin oil film to the shaft only.
 - For **QV** single-nut mounted bearings:
 - Slide the sleeve, non-threaded end first, into position on the shaft.
 - For **QVV** double-nut mounted bearings:
 - Make sure the sleeve nut is flush with the end of the sleeve.
 - Slide the sleeve/nut assembly, nut end first, into position on the shaft.
- Slide the mounted bearing into place over the sleeve.
- Loosely install the mounted bearing mounting bolts. Check the mounted bearing alignment. Verify that the mounting surfaces are in the same flat plane to help achieve good alignment. If shimming is required to minimize misalignment, use full shims across the entire housing base where possible (fig. 37). Washers should be properly sized to bolt diameter and should not be an SAE grade, which is smaller.
- Seat the sleeve as best as possible into the mounted bearing.
- Tighten the wedge assembly by turning the wedge nut clockwise until tight. Please note that it is designed to prevent overtightening.
- If installing a double-nut mounted bearing, tighten the sleeve assembly by turning the sleeve nut clockwise until snug.
- Tighten both the wedge nut and sleeve nut set screws alternately according to fig. 36.
- Install the mounted bearing mounting bolts. Check the mounted bearing alignment. Verify that the mounting surfaces are in the same flat plane to achieve good alignment. If shimming is required to minimize misalignment, use full shims across the entire housing base where possible (fig. 37). The bolts then need to be alternately torqued securely to their mounting supports.

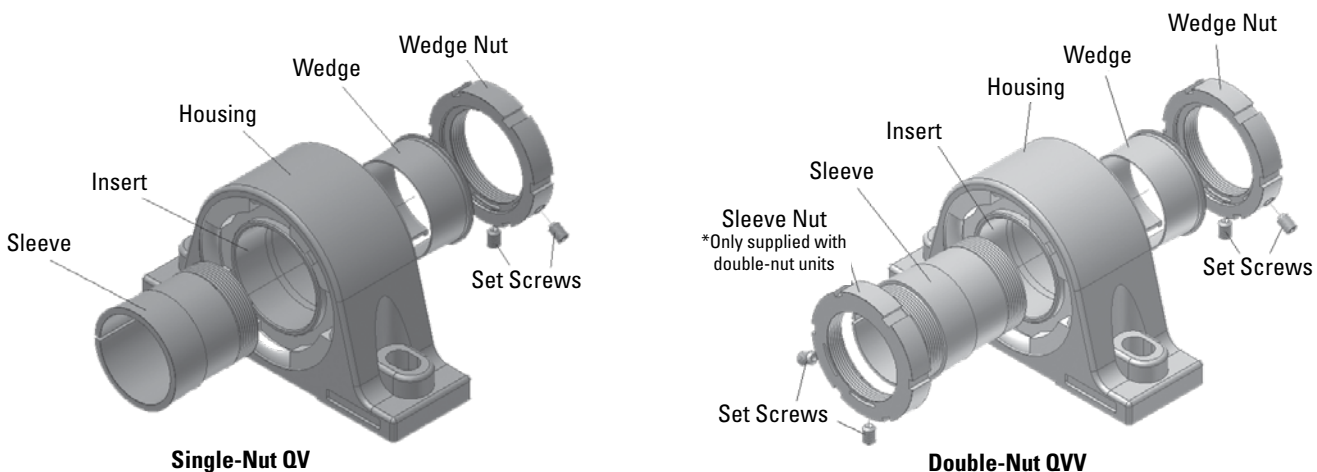

Fig. 36. V-Lock insert components.

TABLE 44. SET SCREW TORQUE VALUES

Shaft Dia.	Bearing No.	Set Screw Size	Torque
mm in.		mm in.	Nm in.-lbs.
50-90 1 15/16 - 3 1/2	SLV11 to SLV20	M10 X 1.5 3/8-24 TPI	32.8 290
100 3 11/16 - 4	SLV22	M12 X 1.75 7/16-20 TPI	47.5 420
110-130 4 7/16 - 5	SLV24 to SLV28	M12 X 1.75 1/2-20 TPI	70.1 620

- Tighten the housing mounting bolts.

If using covers:

- Make sure the mating surface of the cover and retaining nuts are clean and dry.
 - Urethane cover: Slightly roughen the mating surface of the cover, place a 3 mm – 6 mm (1/8 in. – 1/4 in.) bead of polyurethane adhesive sealant on the roughened surface.
 - Steel cover: Place a 3 mm – 6 mm (1/8 in. – 1/4 in.) bead of silicone adhesive sealant on the mating surface of the cover.
- Align the cover mounting holes with the mounting holes on the retaining housing nut (make sure that the grease fitting on the cover is accessible when doing so).
- Apply and tighten the cover mounting hardware.

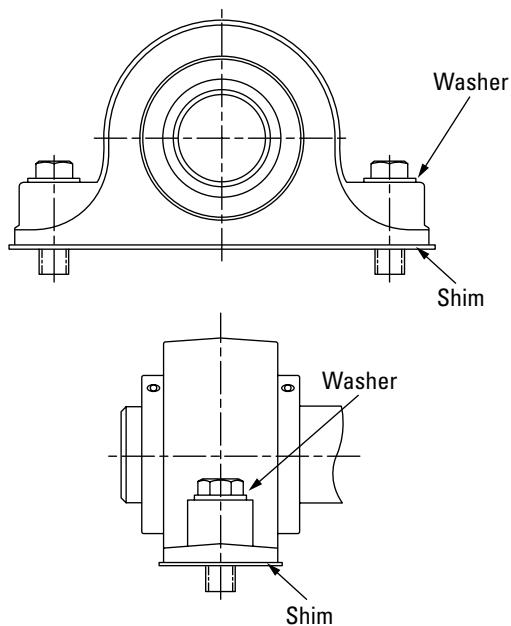

Fig. 37. Use washers and full shims.

REMOVAL

- Remove covers, if applicable, by removing cover hardware and disengaging the cover from the mounted bearing retaining nut.
- Loosen the set screws on the wedge nut.
- Turn the wedge nut counterclockwise to remove the wedge from the locked position.
- Completely remove the wedge/wedge nut assembly.
 - For **QV** mounted bearings:
 - Remove the bearing and sleeve from the shaft.
 - For **QVV** mounted bearings:
 - Loosen the set screws on the sleeve nut.
 - Turn the sleeve nut clockwise to un-seat the sleeve.
 - Remove the bearing and sleeve/sleeve nut from the shaft.

TABLE 45. RECOMMENDED SHAFT TOLERANCES

Shaft Dia.	Bearing No.	Tolerance
mm in.		mm in.
50 1 15/16, 2	22211	+0.00/-0.038 +0.00/-0.0015
55 2 3/16, 2 1/4	22212 22213	
60, 65 2 7/16, 2 1/2	22214 22215	
70, 75 2 11/16, 2 3/4, 2 15/16, 3	22216 22217	+0.00/-0.051 +0.00/-0.0020
80, 85, 90 3 3/16, 3 1/4, 3 7/16, 3 1/2	22219 22220	+0.00/-0.076 +0.00/-0.0030
100 3 11/16, 3 15/16, 4	22222	+0.00/-0.076 +0.00/-0.0030
110, 115 4 7/16, 4 1/2	22224 22226	+0.00/-0.127 +0.00/-0.0050
125, 130 4 15/16, 5	22228	

HOW TO CONVERT A SOLID-BLOCK MOUNTED BEARING FROM FIXED TO EXPANSION (FLOATING)

Flange Cartridge and Flange Block

- Make a reference mark on the housing and retaining nut.
- Loosen the Nylon-tipped set screw that locks the retaining nut in place.
- Loosen the retaining nut by tapping it with a hammer and punch, rotating the retaining nut counterclockwise one complete revolution.
- Tighten the Nylon-tipped set screw.

Pillow Block

- Decide the amount and direction of expansion that's needed. If unidirectional expansion is required, follow the directions outlined in the previous page for flange mounted bearings on the nut that is on the side you want the expansion.
- If multi-directional expansion is required, follow the directions outlined in the previous section for both nuts on flange mounted bearings.

NOTE

When converting a solid-block mounted bearing from fixed to expansion, it is imperative that the unit that is going to be converted is correctly oriented. Since the insert in a steel mounted flange bearing is held against either a shoulder or snap ring opposite the housing retaining nut, a flange bearing that has been converted to expansion can only float in the direction of the retaining nut. Based on this, the retaining nut must be on the side of the housing opposite the fixed bearing.

HOW TO CONVERT A SOLID-BLOCK MOUNTED BEARING FROM EXPANSION (FLOATING) TO FIXED

Flange Cartridge and Flange Block

- Loosen the Nylon-tipped set screw that locks the retaining nut in place.
- Tighten the retaining nut by tapping it with a hammer and punch, rotating the retaining nut clockwise until it's tight. It is not possible to overtighten the retaining nut.
- Tighten the Nylon-tipped set screw.

Pillow Block

- Follow the directions above for flange mounted bearings on both nuts on either side of the housing.

NOTE

When converting a solid-block mounted bearing from expansion to fixed on a mounted bearing, the locking-collar set screws must be released to allow the insert to move both in the housing and on the shaft.



WARNING

Failure to observe the following warnings could create a risk of death or serious injury.

Proper maintenance and handling practices are critical. Always follow installation instructions and maintain proper lubrication.

Overheated bearings can ignite explosive atmospheres. Special care must be taken to properly select, install, maintain, and lubricate mounted bearings that are used in or near atmospheres that may contain explosive levels of combustible gases or accumulations of dust such as from grain, coal, or other combustible materials. Consult your equipment designer or supplier for installation and maintenance instructions.

If hammer and bar are used for installation or removal of a part, use a mild steel bar (e.g., 1010 or 1020 grade). Mild steel bars are less likely to cause release of high speed fragments from the hammer or bar or the part being installed or removed.



CAUTION

Failure to follow these cautions may result in property damage.

Do not use damaged mounted bearings.

LUBRICATION

This information is to aid in the proper lubrication of Timken solid-block mounted spherical roller bearings for the majority of applications.

Mounted bearings have been factory-prelubricated with an NLGI No. 2 lithium-complex, extreme-pressure synthetic grease that combines the benefits of wide operating temperatures and broad compatibility with varied materials. This grease offers excellent thermal stability through temperatures ranging from -40° C to 177° C (-40° F to 350° F). Mounted bearings should be relubricated with this grease or one that is compatible and made for roller bearings. It is vital that the greases used are compatible. Please consult

with your Timken engineer for the grease specifications if the use of a grease other than the grease mentioned above is needed.

Normal service is considered as operation in a clean, dry environment at temperatures between -34° C to +82° C (-30° F to +180° F). If service is beyond normal conditions due to speed, temperature, or exposure to moisture, dirt or corrosive chemicals, more frequent relubrication may be necessary. For extreme conditions or conditions in which special chemicals are used, consult with your Timken engineer.

After extended storage or periods when the mounted bearing is not in operation, fresh grease should be added.

It's important to have the right amount of lubrication, because it affects the mounted bearing operating temperature as well. An inadequate amount of grease could lead to higher operating temperatures due to inadequate lubrication film thickness. Excessive grease also will lead to higher operating temperatures due to grease churning, which can cause bearing overheating. It is best to observe the bearing and its temperature and adjust the lubrication as needed. If necessary, use the purge valve or seals that purge to reduce the amount of grease.

NOTE

Please check with the manufacturer of your grease delivery system for specific information.

RELUBRICATION

Adequate lubrication is an essential element to the mounted bearing life. Use table 46 as a suggested initial point of reference. Relubrication frequency and quantity intervals are best determined through experience for each application, based on types of service, which may differ from the suggestions in the table.

When the mounted bearing is not in operation for an extended period of time, grease should be added to prevent corrosion.

Table 46 shows general lubrication suggested starting points only. Please read the entire installation instructions prior to using these tables. Applications should be regularly reviewed and lubrication amounts and intervals modified as needed to ensure best results.

TABLE 46. RELUBRICATION INTERVALS

Shaft Diameter	Bearing No.	Initial Weight	Relubrication Weight	Relubrication Interval (Hours of Service based on RPM and Temperature deg. F)												
				100 RPM		250 RPM		500 RPM		1000 RPM		2000 RPM		3000 RPM		
				<160°	>160°	<160°	>160°	<160°	>160°	<160°	>160°	<160°	>160°	<160°	>160°	
mm in.		g oz.	g oz.													
50 1 15/16, 2	22211	19.8 0.7	8.5 0.3	1200	600	800	400	440	220	160	80	100	50	60	30	
55 2 3/16, 2 1/4	22212	31.2 1.1	8.5 0.3	1150	580	750	380	400	200	140	70	90	50	50	20	
	22213	34.0 1.2	11.3 0.4	1130	570	740	370	380	190	130	65	85	45	45	20	
60, 65 2 7/16, 2 1/2	22214	42.5 1.5	11.3 0.4	1120	560	720	360	360	180	120	60	80	40	40	20	
	22215	39.7 1.4	14.2 0.5	1080	540	700	350	350	175	110	55	70	35			
70, 75 2 11/16, 2 3/4 2 15/16, 3	22216	53.9 1.9	19.9 0.7	1040	520	680	340	340	170	100	50	60	30			
	22217	59.5 2.1	25.5 0.9	1000	500	640	320	320	160	100	50	60	30			
80, 85, 90 3 3/16, 3 1/4 3 7/16, 3 1/2	22219	99.2 3.5	25.5 0.9	960	480	600	300	300	150	80	40	40	20			
	22220	107.7 3.8	45.4 1.6	840	420	520	260	240	120	70	35	30	18			
100 3 11/16, 3 3/4 3 15/16, 4	22222	153.1 5.4	53.9 1.9	680	340	440	220	200	100	60	30	20	16			
110, 115 4 7/16, 4 1/2	22224	198.4 7.0	68.0 2.4	640	320	400	200	180	90	50	25					
	22226	238.1 8.4	76.5 2.7	560	280	360	180	160	80							
125, 130 4 15/16, 5	22228	326.0 11.5	99.2 3.5	520	260	340	170	140	75							

DISCLAIMER: Every reasonable effort has been made to ensure the accuracy of the information in this writing, but no liability is accepted for errors, omissions or for any other reason.

CL SERIES

Please complete the following steps to install Timken solid-block mounted CL series bearings.

- Ensure that the shaft is clean, free from nicks and burrs, straight and of proper diameter. See table 47 for recommended shaft tolerances. The mounted bearing should not be mounted on a worn section of the shaft. Using shafts with hardness greater than HRC 45 will reduce the effectiveness of locking devices.
- If using an open-end cover, slide the open-end cover/seal combination into position on the shaft.
- Apply a thin oil film to the shaft and bearing bore.
- Slide the mounted bearing into position on the shaft.
- Install the mounted bearing mounting bolts. Check the mounted bearing alignment. Verify mounting surfaces are in the same flat plane to help achieve good alignment. If shimming is required to minimize misalignment, use full shims across the entire housing base where possible (fig. 39). The bolts then need to be alternately torqued securely to their mounting supports.
- Tighten set screws alternately as per table 48. Set screws in multiple units should be aligned to each other (fig. 38).

If using covers:

- Make sure the mating surface of the cover and retaining nuts are clean and dry.
 - Urethane cover: slightly roughen the mating surface of the cover, place a 3 mm – 6 mm (1/8 in. – 1/4 in.) bead of polyurethane adhesive sealant on the roughened surface.
 - Steel cover: place a 3 mm – 6 mm (1/8 in. – 1/4 in.) bead of silicone adhesive sealant on the mating surface of the cover.
- Align the cover mounting holes with the mounting holes on the retaining housing nut (make sure that the grease fitting on the cover is accessible when doing so).
- Apply and tighten the cover mounting hardware.

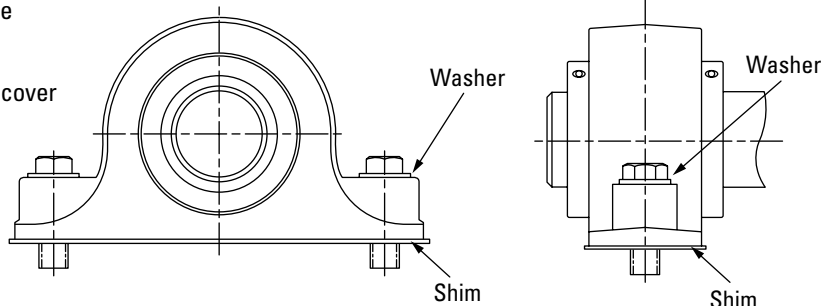

Fig. 39. Use washers and full shims.

TABLE 47. RECOMMENDED SHAFT TOLERANCES

Shaft Dia.	Bearing No.	Tolerance
mm in.		mm in.
35 1 1/4, 1 1/2	22208	+0.00/-0.025 +0.00/0.0010
40, 45 1 1/4, 1 3/4	22209	+0.00/-0.038 +0.00/0.0015
50 1 7/8, 2	22210	+0.00/-0.038 +0.00/-0.0015
55 2 1/4, 2 3/4	22211	+0.00/-0.038 +0.00/-0.0015
60, 65 2 3/8, 2 1/2	22213	+0.00/-0.038 +0.00/-0.0015
70, 75 2 7/8, 2 3/4 2 1/2, 3	22215	+0.00/-0.051 +0.00/-0.0020
80, 85, 90 3 1/4, 3 1/2 3 1/2, 3 1/2	22218	+0.00/-0.076 +0.00/-0.0030
100 3 7/8, 4	22220	+0.00/-0.076 +0.00/-0.0030
110, 115 4 1/4, 4 1/2	22222	+0.00/-0.127 +0.00/-0.0050
125, 130 4 7/8, 5	22226	+0.00/-0.127 +0.00/-0.0050

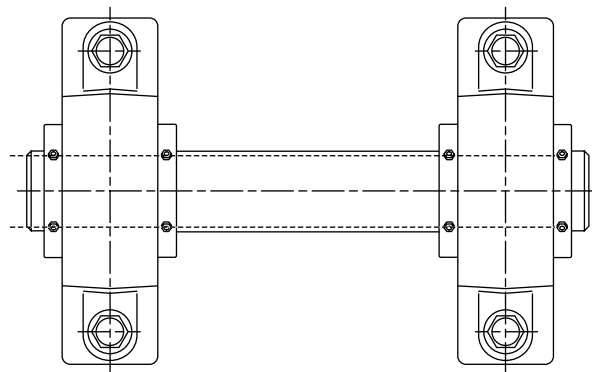

Fig. 38. Line up set screws in multiple units.

TABLE 48. SET SCREW TORQUE VALUES

Shaft Dia.	Bearing No.	Set Screw Size	Torque
mm in.		mm in.	Nm lbs.
35 1 7/16, 1 1/2	22208	M10 X 1.5 3/8 - 24 TPI	32.8 290
40, 45 1 11/16, 1 3/4	22209	M10 X 1.5 3/8 - 24 TPI	32.8 290
50 1 15/16, 2	22210	M10 X 1.5 3/8 - 24 TPI	32.8 290
55 2 3/16, 2 1/4	22211	M10 X 1.5 3/8 - 24 TPI	32.8 290
60, 65 2 7/16, 2 1/2	22213	M12 X 1.75 1/2 - 20 TPI	70.1 620
70, 75 2 11/16, 2 3/4 2 15/16, 3	22215	M12 X 1.75 1/2 - 20 TPI	70.1 620
80, 85, 90 3 3/16, 3 1/4 3 7/16, 3 1/2	22218	M12 X 1.75 1/2 - 20 TPI	70.1 620
100 3 15/16, 4	22220	M16 X 2 5/8 - 18 TPI	149.7 1325
110, 115 4 7/16, 4 1/2	22222	M16 X 2 5/8 - 18 TPI	149.7 1325
125, 130 4 15/16, 5	22226	M16 X 2 5/8 - 18 TPI	149.7 1325

LUBRICATION

This information is to aid in the proper lubrication of Timken solid-block mounted spherical roller bearings for the majority of applications.

Mounted bearings have been factory-prelubricated with an NLGI No. 2 lithium-complex, extreme pressure synthetic grease that combines the benefits of wide operating temperatures and broad compatibility with varied materials. This grease offers excellent thermal stability through temperatures ranging from -40° C to 177° C (-40° F to 350° F). Mounted bearings should be relubricated with this grease or one that is compatible and made for roller bearings. It is vital that the greases used are compatible. Please consult with your Timken engineer for the grease specifications if the use of a grease other than the grease mentioned above is needed.

Normal service is considered as operation in a clean, dry environment at temperatures between -34° C to +82° C (-30° F to +180° F). If service is beyond normal conditions due to speed, temperature, or exposure to moisture, dirt or corrosive chemicals, periodic relubrication may be necessary. For extreme conditions or conditions in which special chemicals are used, consult with your Timken engineer.

After extended storage or periods when the mounted bearing is not in operation, fresh grease should be added.

It is important to have the right amount of lubrication, because it affects the mounted bearing operating temperature as well. An inadequate amount of grease could lead to higher operating temperatures due to inadequate lubrication film thickness. Excessive grease also will lead to higher operating temperatures due to grease churning, which can cause bearing overheating. It is best to observe the bearing and its temperature and adjust the lubrication as needed. If necessary, use the purge valve or seals that purge to reduce the amount of grease.

NOTE

Please check with the manufacturer of your grease delivery system for specific information.

WARNING

Failure to observe the following warnings could create a risk of death or serious injury.

Proper maintenance and handling practices are critical. Always follow installation instructions and maintain proper lubrication.

Overheated bearings can ignite explosive atmospheres. Special care must be taken to properly select, install, maintain, and lubricate mounted bearings that are used in or near atmospheres that may contain explosive levels of combustible gases or accumulations of dust such as from grain, coal, or other combustible materials. Consult your equipment designer or supplier for installation and maintenance instructions.

If hammer and bar are used for installation or removal of a part, use a mild steel bar (e.g., 1010 or 1020 grade). Mild steel bars are less likely to cause release of high speed fragments from the hammer or bar or the part being installed or removed.

CAUTION

Failure to follow these cautions may result in property damage.

Do not use damaged mounted bearings.

RELUBRICATION

Adequate lubrication is an essential element to the mounted bearing life. Use table 49 as a suggested initial point of reference. Relubrication frequency and quantity intervals are best determined through experience for each application based on types of service, which may differ from the suggestions in the table.

When the mounted bearing is not in operation for an extended period of time, grease should be added to prevent corrosion.

Table 49 shows general lubrication suggested starting points only. Please read the entire installation instructions prior to using these tables. Applications should be regularly reviewed and lubrication amounts and intervals modified as needed to ensure the best results.

TABLE 49. RELUBRICATION INTERVALS

Shaft Dia.	Bearing No.	Initial Weight	Relubrication Weight	Relubrication Interval (Hours of Service based on RPM and Temperature deg. F)											
				100 RPM		250 RPM		500 RPM		1000 RPM		2000 RPM		3000 RPM	
				<160°	>160°	<160°	>160°	<160°	>160°	<160°	>160°	<160°	>160°	<160°	>160°
mm in.		g oz.	g oz.												
35 1 7/16, 1 1/2	22208	14.2 0.5	2.4 0.1	2200	1000	1400	700	1000	500	240	120	120	60	40	20
40, 45 1 11/16, 1 3/4	22209	17.0 0.6	5.7 0.2	2000	1000	1200	600	800	400	320	160	160	80	80	40
50 1 15/16, 2	22210	17.0 0.6	5.7 0.2	1600	800	1000	500	640	320	240	120	120	60	60	30
55 2 3/16, 2 1/4	22211	22.7 0.8	8.5 0.3	1200	600	800	400	440	220	160	80	100	50	60	30
60, 65 2 7/16, 2 1/2	22213	39.7 1.4	11.3 0.4	1120	560	720	360	360	180	120	60	80	40	40	20
70, 75 2 11/16, 2 3/4 2 15/16, 3	22215	45.4 1.6	19.4 0.7	1040	520	680	340	340	170	100	50	60	30		
80, 85, 90 3 3/16, 3 1/4 3 7/16, 3 1/2	22218	82.2 2.9	25.5 0.9	960	480	600	300	300	150	80	40	40	20		
100 3 11/16, 3 3/4 3 15/16, 4	22220	121.9 4.3	45.4 1.6	840	420	520	260	240	120	60	30	20	16		
110, 115 4 7/16, 4 1/2	22222	172.9 6.1	53.9 1.9	680	340	440	220	200	100	60	30	20	16		
125, 130 4 15/16, 5	22226	266.5 9.4	76.5 2.7	560	280	360	180	160	80						

DISCLAIMER: Every reasonable effort has been made to ensure the accuracy of the information in this writing, but no liability is accepted for errors, omissions or for any other reason.

HOW TO CONVERT A SOLID-BLOCK MOUNTED BEARING FROM FIXED TO EXPANSION (FLOATING)

Flange Cartridge and Flange Block

- Make a reference mark on the housing and retaining nut.
- Loosen the Nylon-tipped set screw that locks the retaining nut in place.
- Loosen the retaining nut by tapping it with a hammer and punch, rotating the retaining nut counterclockwise one complete revolution.
- Tighten the Nylon-tipped set screw.

NOTE

When converting a solid-block mounted bearing from fixed to expansion, it is imperative that the unit that is going to be converted is correctly oriented. Since the insert in a steel mounted flange bearing is held against either a shoulder or snap ring opposite the housing retaining nut, a flange bearing that has been converted to expansion can only float in the direction of the retaining nut. Based on this, the retaining nut must be on the side of the housing opposite the fixed bearing.

Pillow Block

- Decide the amount and direction of expansion that's needed. If unidirectional expansion is required, follow the directions outlined above for flange bearings on the nut that is on the side you want the expansion.
- If multi-directional expansion is required, follow the directions as outlined above for both nuts on flange mounted bearings.

HOW TO CONVERT A SOLID-BLOCK MOUNTED BEARING FROM EXPANSION (FLOATING) TO FIXED

Flange Cartridge and Flange Block

- Loosen the Nylon-tipped set screw that locks the retaining nut in place.
- Tighten the retaining nut by tapping it with a hammer and punch, rotating the retaining nut clockwise until it's tight. It is not possible to overtighten the retaining nut.
- Tighten the Nylon-tipped set screw.

Pillow Block

- Follow the directions above for flange bearings on both nuts on either side of the housing.

NOTE

When converting a solid-block mounted bearing from expansion to fixed on a mounted bearing, the locking-collar set screws must be released to allow the insert to move both in the housing and on the shaft.

EC SERIES

Please complete the following steps to install Timken EC series solid-block mounted spherical roller bearings.

- Ensure that the shaft is clean, free from nicks and burrs, straight and of proper diameter. See table 50 for recommended shaft tolerances. The mounted bearing should not be mounted on a worn section of the shaft. Using shafts with hardness greater than HRC 45 will reduce the effectiveness of locking devices.
- If using an open-end cover, slide the open-end cover/seal combination into position on the shaft.
- Apply a thin oil film to the shaft and bearing bore.
- Slide the mounted bearing into position on the shaft.
- Install the mounted bearing mounting bolts. Check the mounted bearing alignment. Verify that the mounting surfaces are in the same flat plane to help achieve good alignment. If shimming is required to minimize misalignment, use full shims across the entire housing base where possible (fig. 40). The bolts then need to be alternately torqued securely to their mounting supports.
- Slide the eccentric locking collar along shaft and onto the extended portion of the bearing's inner ring.
- Rotate the eccentric locking collar until it is hand-tight (the direction of rotation does not matter).
- Lock the eccentric locking collar firmly in place by using a spanner wrench or a hammer and drift.
 - When using a hammer and drift, one or two firm, but not too hard, blows will be sufficient due to the shallow eccentric ramp on EC series mounted bearings. Make sure you drive the collar in the same direction in which you hand-tightened it so as to turn it to a tighter position on the bearing's inner ring.
- Tighten the eccentric locking collar set screws alternately as per table 51.

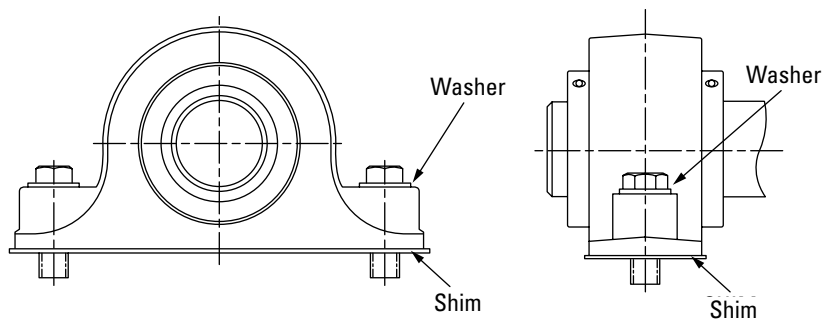

Fig. 40. Use washers and full shims.

If using covers:

- Make sure the mating surface of the cover and retaining nuts are clean and dry.
 - Urethane cover: Slightly roughen the mating surface of the cover, place a 3 mm – 6 mm (1/8 in. – 1/4 in.) bead of polyurethane adhesive sealant on the roughened surface.
 - Steel cover: Place a 3 mm – 6 mm (1/8 in. – 1/4 in.) bead of silicone adhesive sealant on the mating surface of the cover.
- Align the cover mounting holes with the mounting holes on the retaining housing nut (make sure that the grease fitting on the cover is accessible when doing so).
- Apply and tighten the cover mounting hardware.

TABLE 50. RECOMMENDED SHAFT TOLERANCES

Shaft Dia.	Bearing No.	Tolerance
mm in.		mm in.
35 1 7/16, 1 1/2	22208	+0.00/-0.025 +0.00/-0.0010
40, 45 1 11/16, 1 3/4	22209	+0.00/-0.038 +0.00/-0.0015
50 1 15/16, 2	22210	+0.00/-0.038 +0.00/-0.0015
55 2 3/16, 2 1/4	22211	+0.00/-0.038 +0.00/-0.0015
60, 65 2 7/16, 2 1/2	22213	+0.00/-0.038 +0.00/-0.0015
70, 75 2 11/16, 2 3/4 2 15/16, 3	22215	+0.00/-0.051 +0.00/-0.0020
80, 85, 90 3 3/16, 3 1/4 3 7/16, 3 1/2	22218	+0.00/-0.076 +0.00/-0.0030
100 3 11/16, 3 3/4 3 15/16, 4	22220	+0.00/-0.076 +0.00/-0.0030
110, 115 4 7/16, 4 1/2	22222	+0.00/-0.127 +0.00/-0.0050
125, 130 4 15/16, 5	22226	+0.00/-0.127 +0.00/-0.0050
140, 150 5 7/16, 5 1/2 5 15/16, 6	23230	+0.00/-0.127 +0.00/-0.0050
170, 180 6 7/16, 6 1/2 6 15/16, 7	23234	+0.00/-0.127 +0.00/-0.0050

TABLE 51. SET SCREW TORQUE VALUES

Shaft Dia.	Bearing No.	Set Screw Size	Torque
mm in.		mm in.	Nm lbs.
35 1 7/16, 1 1/2	22208	M8 X 1.25 5/16 - 24 TPI	18.6 165
40, 45 1 11/16, 1 3/4	22209	M10 X 1.5 3/8 - 24 TPI	32.8 290
50 1 15/16, 2	22210	M10 X 1.5 3/8 - 24 TPI	32.8 290
55 2 3/16, 2 1/4	22211	M10 X 1.5 3/8 - 24 TPI	32.8 290
60, 65 2 7/16, 2 1/2	22213	M12 X 1.75 7/16 - 20 TPI	70.1 620
70, 75 2 11/16, 2 3/4 2 15/16, 3	22215	M12 X 1.75 7/16 - 20 TPI	70.1 620
80, 85, 90 3 3/16, 3 1/4 3 7/16, 3 1/2	22218	M12 X 1.75 7/16 - 20 TPI	70.1 620
100 3 11/16, 3 3/4 3 15/16, 4	22220	M16 X 2 5/8 - 18 TPI	149.7 1325
110, 115 4 7/16, 4 1/2	22222	M16 X 2 5/8 - 18 TPI	149.7 1325
125, 130 4 15/16, 5	22226	M16 X 2 5/8 - 18 TPI	149.7 1325
140, 150 5 7/16, 5 1/2 5 15/16, 6	23230	M16 X 2 5/8 - 18 TPI	149.7 1325
170, 180 6 7/16, 6 1/2 6 15/16, 7	23234	M16 X 2 5/8 - 18 TPI	149.7 1325

LUBRICATION

This information is to aid in the proper lubrication of Timken solid-block mounted spherical roller bearings for the majority of applications.

Mounted bearings have been factory-prelubricated with an NLGI No. 2 lithium-complex, extreme-pressure synthetic grease that combines the benefits of wide operating temperatures and broad compatibility with varied materials. This grease offers excellent thermal stability through temperatures ranging from -40° C to 177° C (-40° F to 350° F). Mounted bearings should be relubricated with this grease or one that is compatible and made for roller bearings. It is vital that the greases used are compatible. Please consult with your Timken engineer for the grease specifications if the use of a grease other than the grease mentioned above is needed.

Normal service is considered as operation in a clean, dry environment at temperatures between -34° C to +82° C (-30° F to +180° F). If service is beyond normal conditions due to speed, temperature, or exposure to moisture, dirt or corrosive chemicals, periodic relubrication may be necessary. For extreme conditions or conditions in which special chemicals are used, consult with your Timken engineer.

After extended storage or periods when the mounted bearing is not in operation, fresh grease should be added.

It's important to have the right amount of lubrication, because it affects the mounted bearing operating temperature as well. An inadequate amount of grease could lead to higher operating temperatures due to inadequate lubrication film thickness. Excessive grease also will lead to higher operating temperatures due to grease churning, which can cause bearing overheating. It is best to observe the bearing and its temperature and adjust the lubrication as needed. If necessary, use the purge valve or seals that purge to reduce the amount of grease.

NOTE

Please check with the manufacturer of your grease delivery system for specific information.

RELUBRICATION

Adequate lubrication is an essential element to the mounted bearing life. Use table 52 as a suggested initial point of reference. Relubrication frequency and quantity intervals are best developed through experience for each application based on types of service, which may differ from the suggestions in the table.

When the mounted bearing is not in operation for an extended period of time, grease should be added to prevent corrosion.

Table 52 shows general lubrication suggested starting points only. Please read the entire installation instructions prior to using these tables. Applications should be regularly reviewed and lubrication amounts and intervals modified as needed to ensure the best results.



WARNING

Failure to observe the following warnings could create a risk of death or serious injury.

Proper maintenance and handling practices are critical. Always follow installation instructions and maintain proper lubrication.

Overheated bearings can ignite explosive atmospheres. Special care must be taken to properly select, install, maintain, and lubricate mounted bearings that are used in or near atmospheres that may contain explosive levels of combustible gases or accumulations of dust such as from grain, coal, or other combustible materials. Consult your equipment designer or supplier for installation and maintenance instructions.

If hammer and bar are used for installation or removal of a part, use a mild steel bar (e.g., 1010 or 1020 grade). Mild steel bars are less likely to cause release of high speed fragments from the hammer or bar or the part being installed or removed.



CAUTION

Failure to follow these cautions may result in property damage.

Do not use damaged mounted bearings.

DISCLAIMER

Every reasonable effort has been made to ensure the accuracy of the information in this writing, but no liability is accepted for errors, omissions or for any other reason.

TABLE 52. RELUBRICATION INTERVALS

Shaft Dia.	Bearing No.	Initial Weight	Relubrication Weight	Relubrication Interval (Hours of Service based on RPM and Temperature deg. F)											
				100 RPM		250 RPM		500 RPM		1000 RPM		2000 RPM		3000 RPM	
				<160°	>160°	<160°	>160°	<160°	>160°	<160°	>160°	<160°	>160°	<160°	>160°
mm in.		g oz.	g oz.												
35 1 7/16, 1 1/2	22208	14.2 0.5	2.8 0.1	2200	1000	1400	700	1000	500	240	120	120	60	40	20
40, 45 1 11/16, 1 3/4	22209	17.0 0.6	5.7 0.2	2000	1000	1200	600	800	400	320	160	160	80	80	40
50 1 15/16, 2	22210	17.0 0.6	5.7 0.2	1600	800	1000	500	640	320	240	120	120	60	60	30
55 2 3/16, 2 1/4	22211	22.7 0.8	8.5 0.3	1200	600	800	400	440	220	160	80	100	50	60	30
60, 65 2 7/16, 2 1/2	22213	39.7 1.4	11.3 0.4	1120	560	720	360	360	180	120	60	80	40	40	20
70, 75 2 11/16, 2 3/4 2 15/16, 3	22215	45.4 1.6	19.8 0.7	1040	520	680	340	340	170	100	50	60	30		
80, 85, 90 3 3/16, 3 1/4 3 7/16, 3 1/2	22218	82.2 2.9	25.5 0.9	960	480	600	300	300	150	80	40	40	20		
100 3 11/16, 3 3/4 3 15/16, 4	22220	121.9 4.3	45.4 1.6	840	420	520	260	240	120	60	30	20	16		
110, 115 4 7/16, 4 1/2	22222	172.9 6.1	53.9 1.9	680	340	440	220	200	100	60	30	20	16		
125, 130 4 15/16, 5	22226	266.5 9.4	76.5 2.7	560	280	360	180	160	80						
140, 150 5 7/16, 5 1/2 5 15/16, 6	23230	535.8 18.9	147.4 5.2	480	240	320	160	120	68						
170, 180 6 7/16, 6 1/2 6 15/16, 7	23234	805.1 28.4	241.0 8.5	400	160	240	160	110	60						

HOW TO CONVERT A SOLID-BLOCK MOUNTED BEARING FROM FIXED TO EXPANSION (FLOATING)

Flange Cartridge and Flange Block

- Make a reference mark on the housing and retaining nut.
- Loosen the Nylon-tipped set screw that locks the retaining nut in place.
- Loosen the retaining nut by tapping it with a hammer and punch, rotating the retaining nut counterclockwise one complete revolution.
- Tighten the Nylon-tipped set screw.

NOTE

When converting a solid-block mounted bearing from fixed to expansion, it is imperative that the unit that is going to be converted is correctly oriented. Since the insert in a steel mounted flange bearing is held against either a shoulder or snap ring opposite the housing retaining nut, a flange bearing that has been converted to expansion can only float in the direction of the retaining nut. Based on this, the retaining nut must be on the side of the housing opposite the fixed bearing.

Pillow Block

- Decide the amount and direction of expansion that's needed. If unidirectional expansion is required, follow the directions outlined above for flange bearings on the nut that is on the side you want the expansion.
- If multi-directional expansion is required, follow the directions outlined above for both nuts on flange mounted bearings.

HOW TO CONVERT A SOLID-BLOCK MOUNTED BEARING FROM EXPANSION (FLOATING) TO FIXED

Flange Cartridge and Flange Block

- Loosen the Nylon-tipped set screw that locks the retaining nut in place.
- Tighten the retaining nut by tapping it with a hammer and punch, rotating the retaining nut clockwise until it's tight. It is not possible to overtighten the retaining nut.
- Tighten the Nylon-tipped set screw.

Pillow Block

- Follow the directions above for flange bearings on both nuts on either side of the housing.

NOTE

When converting a solid-block mounted bearing from expansion to fixed on a mounted bearing, the locking collar set screws must be released to allow the insert to move both in the housing and on the shaft.

TA/DV TAA/DAA SERIES

INSTALLATION PROCEDURE

Depending on the locking style selection and the size of the bearing choose one of the three methods for installing your mounted bearing. The single nut tapered adapter and the double nut tapered adapter for shaft sizes 5 in. and below (bearing 22228 and smaller) can be installed by either using the axial drive-up method or the tang count method. When using double nut tapered adapters for shaft sizes 135 mm and larger (bearing 22232 and larger) use the TAA/DAA (large sizes) double nut tapered adapter installation procedure.

AXIAL DRIVE-UP METHOD

- Clean all components of any debris and apply a thin oil film to all mating surfaces to ensure proper seating.
- If using an open-end cover, slide the open-end cover/seal combination into position on the shaft.
- For double nut tapered adapters, back off the withdrawal nut by turning it counterclockwise until it only has one or two threads of engagement holding it onto the adapter.
- Slide the adapter sleeve into position on the shaft, then put the mounted bearing into place on the adapter sleeve.
- Loosely install the mounted bearing mounting bolts. Check the mounted bearing alignment. Verify mounting surfaces are in the same flat plane to help achieve good alignment. If shimming is required to minimize misalignment, use full shims across the entire housing base where possible (fig. 41). Washers should be properly sized to the bolt diameter and should not be an SAE grade, which is smaller.
- Put the lockwasher on and thread the locknut onto the adapter sleeve leaving approximately 6.350 mm (¼ in.) between the lockwasher and the inner ring of the bearing.
- Use a large screwdriver or pry bar to lever the sleeve into position until there is no relative movement between the shaft, the adapter sleeve, and the bearing's inner ring.
- Rotate the locknut until hand-tight.
- Tighten the locknut while using a dial indicator to measure the axial movement of the tapered adapter sleeve relative to the bearing's inner ring (see table 53).
- Bend a tang on the lockwasher into a slot on the locknut to prevent the locknut from loosening.
- For double nut tapered adapters, tighten the withdrawal nut by turning it clockwise until it contacts the inner ring of the bearing, tightening the withdrawal nut until snug. Bend a tang on the withdrawal nut lock washer into a slot on the withdrawal nut to prevent the withdrawal nut from loosening.
- Tighten the mounted bearing mounting bolts.

If using covers:

- Make sure the mating surface of the cover and retaining nuts are clean and dry.
 - Urethane cover: Slightly roughen the mating surface of the cover, place a 3 mm – 6 mm (1/8 in. – 1/4 in.) bead of polyurethane adhesive sealant on the roughened surface.
 - Steel cover: Place a 3 mm – 6 mm (1/8 in. – 1/4 in.) bead of silicone adhesive sealant on the mating surface of the cover.
- Align the cover mounting holes with the mounting holes on the retaining housing nut (make sure that the grease fitting on the cover is accessible when doing so).
- Apply and tighten the cover mounting hardware.

TABLE 53. AXIAL MOVEMENT OF TAPERED ADAPTER SLEEVE RELATIVE TO INNER RING

Shaft Dia.	Bearing No.	Minimum Axial Movement	Maximum Axial Movement
mm in.		mm in.	mm in.
40 1 7/16, 1 1/2	22209	0.38 0.015	0.46 0.018
45 1 11/16, 1 3/4	22210	0.38 0.015	0.46 0.018
50 1 15/16, 2	22211	0.46 0.018	0.56 0.022
55 —	22212	0.46 0.018	0.56 0.022
60 2 3/16, 2 1/4	22213	0.46 0.018	0.56 0.022
65 2 7/16, 2 1/2	22215	0.64 0.025	0.76 0.030
70 2 11/16, 2 3/4	22216	0.64 0.025	0.76 0.030
75 2 15/16, 3	22217	0.69 0.027	0.97 0.038
80 3 3/16, 3 1/4	22218	0.69 0.027	0.97 0.038
85 —	22219	0.69 0.027	0.97 0.038
90 3 7/16, 3 1/2	22220	0.69 0.027	0.97 0.038
100 3 15/16, 4	22222	0.76 0.030	1.07 0.042
110 4 3/16, 4 1/4	22224	0.76 0.030	1.07 0.042
115 4 7/16, 4 1/2	22226	0.89 0.035	1.27 0.050
125 4 15/16, 5	22228	0.89 0.035	1.27 0.050

TANG COUNTING METHOD

- Clean all components of any debris and apply a thin oil film to all mating surfaces to ensure proper seating.
- If using an open-end cover, slide the open-end cover/seal combination into position on the shaft.
- For double nut tapered adapters, back off the withdrawal nut by turning it counterclockwise until it only has one or two threads of engagement holding it onto the adapter.
- Slide the adapter sleeve into the correct position on the shaft, then put the mounted bearing into place on the adapter sleeve.
- Loosely install the mounted bearing mounting bolts. Check the mounted bearing alignment. Verify mounting surfaces are in the same flat plane to help achieve good alignment. If shimming is required to minimize misalignment, use full shims across the entire housing base where possible (fig. 41). Washers should be properly sized to the bolt diameter and should not be an SAE grade, which is smaller.
- Put the lockwasher on and thread the locknut onto the adapter sleeve leaving approximately 6.350 mm (¼ in.) between the lockwasher and the inner ring of the bearing.
- Use a large screwdriver or pry bar to lever the sleeve into position until there is no relative movement between the shaft, the adapter sleeve and the bearing's inner ring.
- Rotate the locknut until hand-tight.
- Note which tang is in line with one slot on the locknut.
- Tighten the locknut until the slot on the locknut passes the number of tangs shown in table 54.
- Bend a tang on the lockwasher into a slot on the locknut to prevent the locknut from loosening.
- For double nut tapered adapters, tighten the withdrawal nut by turning it clockwise until it contacts the inner ring of the bearing, tightening the withdrawal nut until snug. Bend a tang on the withdrawal nut lock washer into a slot on the withdrawal nut to prevent the withdrawal nut from loosening.
- Tighten the mounted bearing mounting bolts.

If using covers:

- Make sure the mating surface of the cover and retaining nuts are clean and dry.
 - Urethane cover: Slightly roughen the mating surface of the cover, place a 3 mm – 6 mm (1/8 in. – 1/4 in.) bead of polyurethane adhesive sealant on the roughened surface.
 - Steel cover: Place a 3 mm – 6 mm (1/8 in. – 1/4 in.) bead of silicone adhesive sealant on the mating surface of the cover.
- Align the cover mounting holes with the mounting holes on the retaining housing nut (make sure that the grease fitting on the cover is accessible when doing so).
- Apply and tighten the cover mounting hardware.

TABLE 54. NUMBER OF TANGS TO LOCKING

Shaft Dia.	Bearing No.	Number of Tangs
mm in.		
40 1 7/16, 1 1/2	22209	3-4
45 1 11/16, 1 3/4	22210	3-4
50 1 13/16, 2	22211	4-5
55 —	22212	4-5
60 2 3/16, 2 1/4	22213	4-5
65 2 7/16, 2 1/2	22215	5-6
70 2 11/16, 2 3/4	22216	5-6
75 2 13/16, 3	22217	8-9
80 3 3/16, 3 1/4	22218	8-9
85 —	22219	8-9
90 3 7/16, 3 1/2	22220	8-9
100 3 15/16, 4	22222	10-11
110 4 3/16, 4 1/4	22224	10-11
115 4 7/16, 4 1/2	22226	10-11
125 4 13/16, 5	22228	10-11

TAA/DAA SERIES (LARGE SERIES) INSTALLATION PROCEDURE

These instructions are for large sizes of the TAA/DAA series double nut tapered adapter, to be used for shaft sizes 130 mm and up (bearing sizes 22232 and larger).

- Clean all components of any debris and apply a thin oil film to all mating surfaces to ensure proper seating.
- If using an open-end cover, slide the open-end cover/seal combination into position on the shaft.
- Check that the withdrawal nut settings are appropriate for the application shaft size. The axial measurement of the withdrawal nut of the tapered adapter is preset from the factory assuming the shaft is to commercial grade tolerances. If the shaft is smaller or larger than commercial grade tolerances, calculate the amount of rotation to adjust the withdrawal nut from the values in table 55 under the withdrawal nut adjustment column (values listed are based on $\frac{1}{4}$ turn of the withdrawal nut). For smaller than commercial tolerance shaft, turn the withdrawal nut counter-clockwise. For larger than commercial tolerance shaft, turn the withdrawal nut clockwise when looking at front face of the nut. The lockwasher or lock plate will need to be disengaged before rotating the withdrawal nut.
 - If the customer feels the adapter has changed from the pre-set value that has been provided, use the tang counting method up to size 40, axial drive up method, or reach out to a local Timken engineer.
- Slide the adapter sleeve and withdrawal nut into the correct position on the shaft, then put the mounted bearing into place on the adapter sleeve.
- Loosely install the mounted bearing mounting bolts. Check the mounted bearing alignment. Verify mounting surfaces are in the same flat plane to help achieve good alignment. If shimming is required to minimize misalignment, use full shims across the entire housing base where possible (fig. 41). Washers should be properly sized to the bolt diameter and should not be an SAE grade, which is smaller.
- Rotate front locknut by hand until it makes contact with inner ring. Using a wrench, further tighten the front locknut until the inner ring makes contact with the inner face of the withdrawal nut. A hydraulic nut also may be used to do this; however, the front locknut must first be removed, then the bearing tightened with a hydraulic nut.
- For bearing sizes 23132K to 23140K, secure the front locknut by bending a tang on the lockwasher into the closest notch on the locknut. For bearing sizes 23144K and larger, secure the front locknut by fixing the lockplate into the closest notch on the locknut.
- Tighten the mounted bearing mounting bolts.

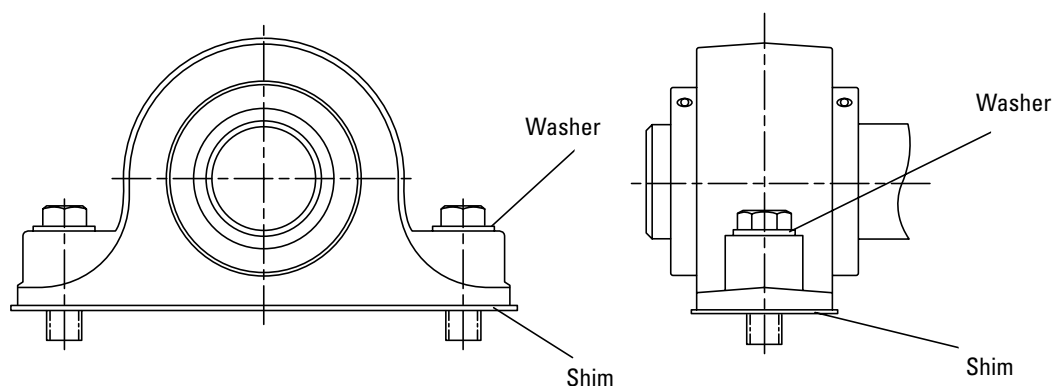

Fig. 41. Use washers and full shims.

CROSS-SECTIONAL VIEW OF BEARINGS

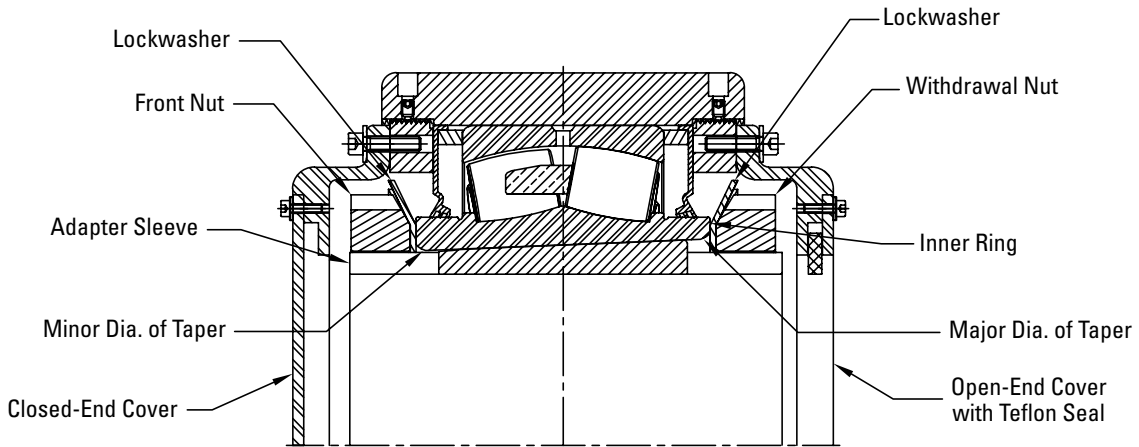

Fig. 42. Cross-sectional view of bearing sizes 23132K to 23140K.

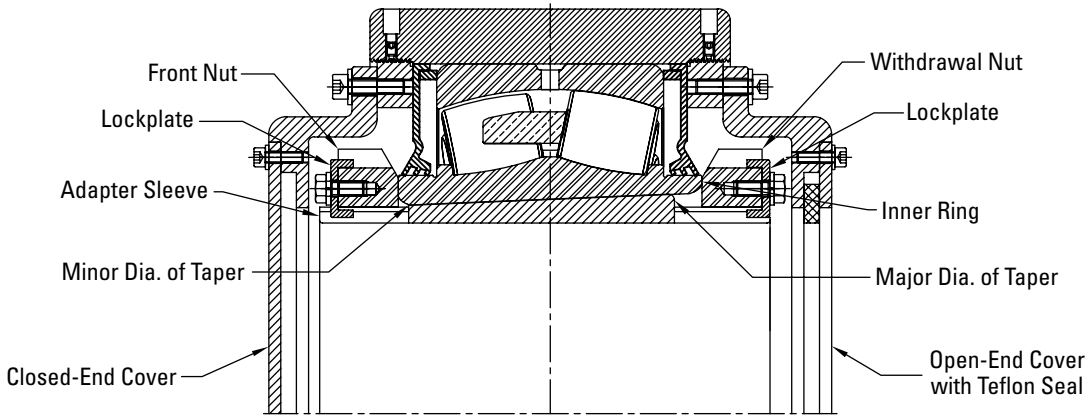

Fig. 43. Cross-sectional view of bearing sizes 23144K and larger.

TABLE 55. INSTALLATION DATA

Shaft Diameter	Bearing Part No.	Max. Speed (O-Seals)	Adapter Thread Spec.	Recommended Shaft Tolerance	Withdrawal Nut Initial Setting	Withdrawal nut adjustment based on a ¼ turn ⁽¹⁾
mm in.		RPM		mm in.	mm in.	mm in.
135, 140 5 ⅜, 5 ⅞, 5 ½	23132K	500	M160 x 3	+0.00 / -0.125 +0.000 / -0.005	5.17 0.203	0.063 0.0025
150 5 ⅜, 5 ⅞, 5 ⅞, 6	23134K	470	M170 x 3	+0.00 / -0.125 +0.000 / -0.005	-1.05 -0.042	0.063 0.0025
160 6 ⅝, 6 ¾, 6 ⅞, 6 ½	23136K	430	M180 x 3	+0.00 / -0.125 +0.000 / -0.005	-0.31 -0.012	0.063 0.0025
170 6 ⅜, 6 ⅞, 6 ⅞, 7	23138K	400	M190 x 3	+0.00 / -0.125 +0.000 / -0.005	-1.37 -0.054	0.063 0.0025
180 7 ⅞, 7 ⅞, 7 ¼	23140K	400	M200 x 3	+0.00 / -0.125 +0.000 / -0.005	-1.33 -0.052	0.063 0.0025
200 7 ⅜, 7 ⅞, 7 ⅞, 8	23144K	330	Tr220 x 4	+0.00 / -0.125 +0.000 / -0.005	3.07 0.121	0.083 0.0033
220 8 ⅞, 8 ½, 8 ⅞, 9	23148K	310	Tr240 x 4	+0.00 / -0.152 +0.000 / -0.006	2.71 0.107	0.083 0.0033
240 9 ⅞, 9 ½	23152K	250	Tr260 x 4	+0.00 / -0.152 +0.000 / -0.006	2.65 0.104	0.083 0.0033
260 9 ⅞, 10, 10 ⅞, 10 ½	23156K	240	Tr280 x 4	+0.00 / -0.178 +0.000 / -0.007	2.58 0.101	0.083 0.0033
280 10 ⅞, 11	23160K	210	Tr300 x 4	+0.00 / -0.178 +0.000 / -0.007	0.48 0.019	0.083 0.0033
300 11 ⅞, 11 ½, 11 ⅞, 12	23164K	190	Tr320 x 5	+0.00 / -0.178 +0.000 / -0.007	0.30 0.012	0.104 0.0041
320 12 ⅞, 12 ½	23168K	180	Tr340 x 5	+0.00 / -0.203 +0.000 / -0.008	0.34 0.013	0.104 0.0041
340 12 ⅞, 13, 13 ⅞, 13 ½	23172K	170	Tr360 x 5	+0.00 / -0.203 +0.000 / -0.008	0.09 0.003	0.104 0.0041
360 13 ⅞, 14	23176K	160	Tr380 x 5	+0.00 / -0.203 +0.000 / -0.008	0.00 0.00	0.104 0.0041
380 14 ⅞, 15	23180K	150	Tr400 x 5	+0.00 / -0.203 +0.000 / -0.008	0.00 0.00	0.104 0.0041

⁽¹⁾ Calculation would be: Adjustment turns = (0.25 x (preset shaft size – measured shaft size)) / Withdrawal nut adjustment value from table.
For example, if the shaft is undersized by 0.001 in., you would back off the withdrawal nut by ⅓ of a turn (or 36 degrees), as shown by the following calculation.
If you have a 5 ⅞ in. shaft that is undersized by 0.001 in. (0.25 x (5.4375 in. – 5.4365 in.)) / 0.0025 in.) = 0.1 turns = ⅓ of a turn.
Or in degrees, this would be 360 degrees/10 = 36 degrees.

COVER INSTALLATION

- Make sure the mating surface of the cover and retaining nuts are clean and dry.
- Steel cover: Place a 3-6 mm (1/8 in. – 1/4 in.) bead of silicone adhesive sealant on the mating surface of the cover.
- Align the cover mounting holes with the mounting holes on the retaining housing nut (make sure that the grease fitting on the cover is accessible when doing so).
- Apply and tighten the cover mounting hardware.

TAA/DAA BEARING REMOVAL

- Remove covers, if applicable, by removing cover hardware and disengaging the cover from the mounted bearing retaining nut.
- Disengage locknut retainer on lockwasher on both front and withdrawal locknuts.
- Remove front locknut.
- Tighten withdrawal nut to disengage bearing from adapter sleeve.
- Slide off bearing, then slide off adapter sleeve.

RELUBRICATION

This information is to aid in the proper lubrication of Timken solid-block mounted spherical roller bearings for the majority of applications.

Mounted bearings have been factory-prelubricated with an NLGI No. 2 lithium-complex, extreme-pressure synthetic grease that combines the benefits of wide operating temperatures and broad compatibility with varied materials. This grease offers excellent thermal stability through temperatures ranging from -40° C to 177° C (-40° F to 350° F). Mounted bearings should be relubricated with this grease or one that is compatible and made for roller bearings. It is vital that the greases used are compatible with the factory installed grease. Please consult with your Timken engineer for the grease specifications if the use of a grease other than the grease mentioned above is needed.

Normal service is considered as operation in a clean, dry environment at temperatures between -34° C to +82° C (-30° F to +180° F). If service is beyond normal conditions due to speed, temperature or exposure to moisture, dirt or corrosive chemicals, periodic relubrication may be necessary. For extreme conditions or conditions in which special chemicals are used, consult with your Timken engineer.

After extended storage or periods when the mounted bearing is not in operation, fresh grease should be added.

It's important to have the right amount of lubrication because it affects the mounted bearing operating temperature as well. An inadequate amount of grease could lead to higher operating temperatures due to inadequate lubrication film thickness. Excessive grease will lead to higher operating temperatures due to grease churning, which can cause bearing overheating. It is best to observe the bearing and its temperature and adjust the lubrication as needed. If necessary, use the purge valve or seals that purge to reduce the amount of grease.

Adequate lubrication is an essential element to the mounted bearing life. Use table 56 as a suggested initial point of reference. Relubrication frequency and quantity intervals are best determined through experience for each application based on types of service, which may differ from the suggestions in the table.

When the mounted bearing is not in operation for an extended period of time, grease should be added to prevent corrosion.

Table 56 shows general lubrication suggested starting points only. Please read the entire installation instructions prior to using these tables. Applications should be regularly reviewed and lubrication amounts and intervals modified as needed to ensure the best results.

NOTE

Please check with the manufacturer of your grease delivery system for specific information.

TABLE 56. RELUBRICATION INTERVALS

Shaft Dia.	Bearing Part No.	Initial Weight	Relubrication Weight	Relubrication Interval (Hours of Service based on RPM and Temperature deg. F)											
				100 RPM		250 RPM		500 RPM		1000 RPM		2000 RPM		3000 RPM	
				<160°	>160°	<160°	>160°	<160°	>160°	<160°	>160°	<160°	>160°	<160°	>160°
mm in.		g oz.	g oz.												
40 1 1/16, 1 1/2	22209	14.2 0.5	5.7 0.2	2000	1000	1200	600	800	400	320	160	160	80	80	40
45 1 11/16, 1 3/4	22210	14.2 0.5	5.7 0.7	1600	800	1000	500	640	320	240	120	120	60	60	30
50 1 13/16, 2	22211	19.8 0.7	8.5 0.3	1200	600	800	400	440	220	160	80	100	50	60	30
55 —	22212	25.5 0.9	8.5 0.3	1150	580	750	380	400	200	140	70	90	50	50	20
60 2 3/16, 2 1/4	22213	34.0 1.2	11.3 0.4	1120	560	720	360	360	180	120	60	80	40	40	20
65 2 7/16, 2 1/2	22215	39.7 1.4	19.8 0.7	1040	520	680	340	340	170	100	50	60	30		
70 2 11/16, 2 3/4	22216	48.2 1.7	19.8 0.7	1040	520	680	340	340	170	10	50	60	30		
75 2 15/16, 3	22217	59.5 2.1	25.5 0.9	1000	500	640	320	320	160	100	50	60	30		
80 3 3/16, 3 1/4	22218	73.7 2.6	25.5 0.9	960	480	600	300	300	150	80	40	40	20		
85 —	22219	90.7 3.2	25.5 0.9	960	480	600	300	300	150	80	40	40	20		
90 3 7/16, 3 1/2	22220	107.7 3.8	45.4 1.6	840	420	520	260	240	120	60	30				
100 3 15/16, 4	22222	153.1 5.4	53.9 1.9	680	340	440	220	200	100	60	30				
110 4 3/16, 4 1/4	22224	198.4 7.0	68.0 2.4	640	320	400	200	180	90	50	25				
115 4 7/16, 4 1/2	22226	238.1 8.4	85.0 3.0	600	300	360	180	160	80	40	20				
125 4 15/16, 5	22228	294.8 10.4	99.2 3.5	520	260	340	170	140	75						
135 5 3/16, 5 1/4	23130	428.0 15.1	108 3.8	500	250	330	165	130	65						
140 5 3/8, 5 7/16, 5 1/2	23132	450.8 15.9	116 4.1	480	240	320	160	120	60						
150 5 13/16, 5 7/8, 5 15/16, 6	23134	499.0 17.6	122 4.3	420	200	280	140	110	60						
160 6 5/16, 6 3/8, 6 7/16, 6 1/2	23136	629.4 22.2	145 5.1	400	180	240	120								
170 6 13/16, 6 7/8, 6 15/16, 7	23138	782.4 27.6	167 5.9	380	160	200	110								
180 7 1/8, 7 3/16, 7 1/4	23140	921.4 32.5	190 6.7	350	150	150	90								
200 7 13/16, 7 7/8, 7 15/16, 8	23144	1179.3 41.6	221 7.8	320	140	110	60								
220 8 7/16, 8 1/2, 8 15/16, 9	23148	1434.5 50.6	255 9.0	290	130	85	45								
240 9 7/16, 9 1/2	23152	1961.8 69.2	318 11.2	260	120	60	30								
260 9 15/16, 10, 10 7/16, 10 1/2	23156	2109.2 74.4	335 11.8	230	110										
280 10 15/16, 11	23160	2772.6 97.8	400 14.1	200	100										
300 11 7/16, 11 1/2, 11 15/16, 12	23164	3574.9 126.1	476 16.8	170	90										
320 12 7/16, 12 1/2	23168	4371.5 154.2	550 19.4	140	80										
340 12 15/16, 13, 13 7/16, 13 1/2	23172	4465.0 157.5	576 20.3	110	60										
360 13 15/16, 14	23176	4924.3 173.7	601 21.2	85	45										
380 14 15/16, 15	23180	5525.3 194.9	649 22.9	60	30										

HOW TO CONVERT A SOLID-BLOCK MOUNTED BEARING FROM FIXED TO EXPANSION (FLOATING)

Flange Cartridge and Flange Block

- Make a reference mark on the housing and retaining nut.
- Loosen the Teflon-tipped set screw that locks the retaining nut in place.
- Loosen the retaining nut by tapping it with a hammer and punch, rotating the retaining nut counterclockwise one complete revolution.
- Tighten the Teflon-tipped set screw.

NOTE

When converting a solid-block mounted bearing from fixed to expansion, it is imperative that the unit that is going to be converted is correctly oriented. Since the insert in a steel mounted flange bearing is held against either a shoulder or snap ring opposite the housing retaining nut, a flange bearing that has been converted to expansion can only float in the direction of the retaining nut. Based on this, the retaining nut must be on the side of the housing opposite the fixed bearing.

Pillow Block

- Decide the amount and direction of expansion that's needed. If unidirectional expansion is required, follow the directions outlined above for flange bearings on the nut that is on the side you want the expansion.
- If multi-directional expansion is required, follow the directions above for both nuts on flange mounted bearings.

HOW TO CONVERT A SOLID-BLOCK MOUNTED BEARING FROM EXPANSION (FLOATING) TO FIXED

Flange Cartridge and Flange Block

- Loosen the Teflon-tipped set screw that locks the retaining nut in place.
- Tighten the retaining nut by tapping it with a hammer and punch, rotating the retaining nut clockwise until tight. It is not possible to overtighten the retaining nut.
- Tighten the Teflon-tipped set screw.

Pillow Block

- Follow the directions above for flange bearings on both nuts on either side of the housing.

NOTE

When converting a solid-block mounted bearing from expansion to fixed on a mounted bearing, the locking-collar set screws must be released to allow the insert to move both in the housing and on the shaft.



WARNING

Failure to observe the following warnings could create a risk of death or serious injury.

Proper maintenance and handling practices are critical. Always follow installation instructions and maintain proper lubrication.

Overheated bearings can ignite explosive atmospheres. Special care must be taken to properly select, install, maintain, and lubricate mounted bearings that are used in or near atmospheres that may contain explosive levels of combustible gases or accumulations of dust such as from grain, coal, or other combustible materials. Consult your equipment designer or supplier for installation and maintenance instructions.

If hammer and bar are used for installation or removal of a part, use a mild steel bar (e.g., 1010 or 1020 grade). Mild steel bars are less likely to cause release of high speed fragments from the hammer or bar or the part being installed or removed.



CAUTION

Failure to follow these cautions may result in property damage.

Do not use damaged mounted bearings.

DISCLAIMER

Every reasonable effort has been made to ensure the accuracy of the information in this writing, but no liability is accepted for errors, omissions or for any other reason.



V-LOCK SERIES

The V-Lock locking mechanism (U.S. Pat. No. 7344313) evenly distributes force on the shaft, helping eliminate fretting corrosion. V-Lock provides maximum holding power and prevents overtightening.

The following topics are covered within this section:

Introduction	90
QVP and QVVP Two-Bolt Pillow Blocks	92
QVPL and QVPL Two-Bolt Pillow Blocks	94
QVPA and QVPA SAF Two-Bolt Pillow Blocks	96
QVPN and QVVPN SN-Style Two-Bolt Pillow Blocks	98
QVSN and QVSN SN-Style Two-Bolt Pillow Blocks	100
QVPKT and QVVPKT 9000 Series Two-Bolt Pillow Blocks	102
QVPF and QVVPF Four-Bolt Pillow Blocks	103
QVPR and QVVPR Four-Bolt Pillow Blocks	105
QVPX and QVVPX 5000 Series Four-Bolt Pillow Blocks	106
QVPXT and QVVPXT 5000 Series Two-Bolt Pillow Blocks	108
QVPG and QVPG SN-Style Four-Bolt Pillow Blocks	109
QVPH and QVPH SAF-Style Four-Bolt Pillow Blocks	111
QVPK and QVVPK 9000 Series Four-Bolt Pillow Blocks	113
QVF and QVVF Square Flange Blocks	115
QVFB and QVFB Square Flange Blocks	117
QVFC and QVFC Piloted Flange Cartridges	119
QVFL and QVFL Square Flange Blocks	121
QVFX and QVFX 5000 Series Square Flange Blocks	123
QVFK and QVFK 9000 Series Square Flange Blocks	125
QVFNL Series Square Flange Blocks	127
QVfy and QVfy Round Flange Blocks	128
QVC and QVVC Piloted Flange Cartridges	130
QVCW and QVVCW Piloted Flange Cartridges	132
QVMC and QVMC Cartridge Blocks	134
QVVTU Take-Up Blocks	136

V-LOCK SERIES

The V-Lock series is specifically designed to address common solid-block mounted spherical roller bearing problems:

- Reliable mechanical withdrawal
- Preset spherical inner ring radial internal clearances (feeler gages are not required)
- Quick installation (typically 10 minutes or less)
- Highest shaft-holding power
- Works well in high-speed applications where shaft centering is an issue



Fig. 44. V-Lock series insert.

YOU HAVE CHOICES

For the V-Lock series, you can select either single-nut or double-nut versions and choose from many seal configurations and housing styles, which are shown on page 15.

HOUSINGS

- Two-bolt pillow blocks
- Four-bolt pillow blocks
- Flange blocks
- Piloted flange cartridges
- Cartridge blocks
- Take-up blocks

SEALS

- Labyrinth: DuPont™ Teflon® (T)
- Triple-lip: nitrile rubber (M), urethane (O) and Viton® (N)
- Double-lip: nitrile rubber (B) and Viton (C)
- Steel and urethane closed-end covers (CS)
- Steel and urethane open-end covers (CV) with:
 - DuPont Teflon (T)
 - Triple-lip seal (DR)
 - V-ring seal (VR)

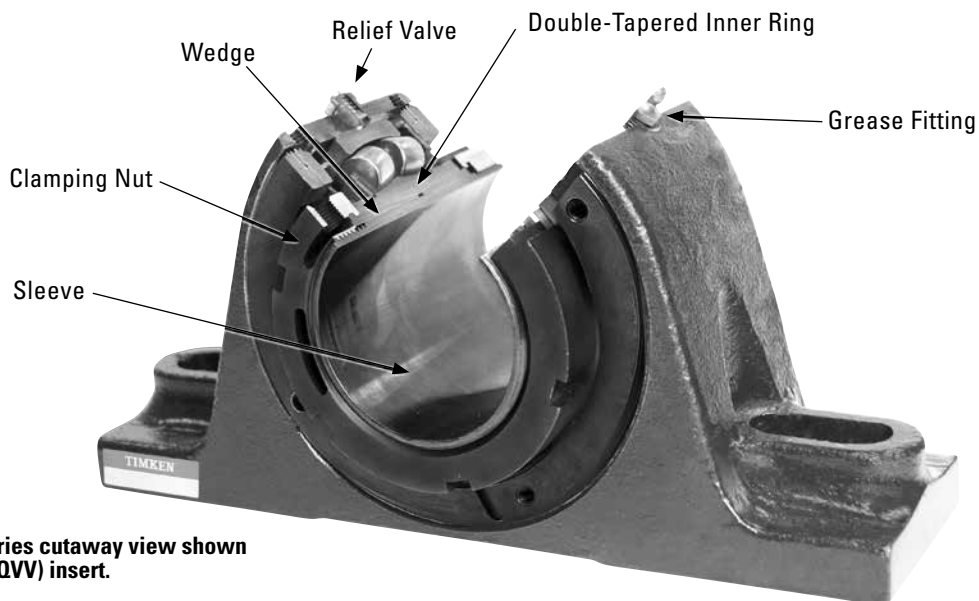

Fig. 45. V-Lock series cutaway view shown with double-nut (QVV) insert.

V-LOCK SERIES WRENCH

New V-Lock series wrenches make installation easy; the wrenches are specifically designed for the V-Lock adapter sleeves, providing three or four points of contact and maximum wrench engagement versus traditional spanner wrench designs. Made from tough high alloy steel for long service life. Eight wrenches are all you need for the 36 different bore sizes.

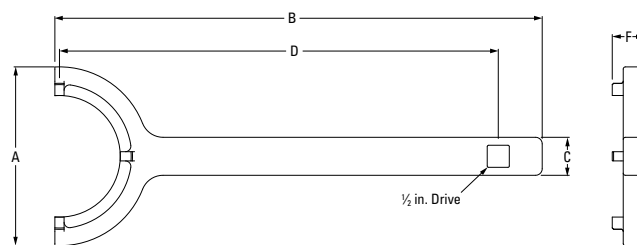

Fig. 46. V-Lock series wrench.



TABLE 57. V-LOCK SERIES WRENCH DIMENSIONS

Part #	Shaft Dia.	A	B	C	D	F	Wt.
	mm in.	mm in.	mm in.	mm in.	mm in.	mm in.	kg lbs.
AVWR11	1 15/16 in. 2 in. 50 mm	103.5 4.07	282.1 11.10	22.0 0.87	254.0 10.00	19.1 0.75	0.67 1.5
AVWR12-13	2 3/16 in. 2 1/4 in. 55 mm	107.0 4.21	307.6 12.11	22.0 0.87	279.5 11.00	19.1 0.75	0.74 1.6
AVWR14-15	60 mm 2 7/16 in. 2 1/2 in. 65 mm	126.0 4.95	358.2 14.10	22.0 0.87	330.2 13.00	19.1 0.75	0.92 2.0
AVWR16-17	2 11/16 in. 2 3/4 in. 70 mm 2 15/16 in. 3 in. 75 mm	138.0 5.43	383.5 15.10	22.0 0.87	355.5 14.00	19.1 0.75	0.97 2.1
AVWR19-20	3 3/16 in. 3 1/4 in. 80 mm 85 mm 3 7/16 in. 3 1/2 in. 90 mm	161.0 6.34	408.9 16.10	33.0 1.30	380.9 15.00	21.6 0.85	1.45 3.2
AVWR22	3 11/16 in. 3 3/4 in. 100 mm 3 15/16 in. 4 in.	176.0 6.93	434.3 17.10	33.0 1.30	406.3 16.00	29.2 1.15	2.37 5.2
AVWR26	110 mm 4 7/16 in. 4 1/2 in. 115 mm	216.0 8.50	485.3 19.11	33.0 1.30	457.3 18.00	29.2 1.15	2.80 6.2
AVWR28	125 mm 4 15/16 in. 5 in. 130 mm	232.0 9.13	536.0 21.10	33.0 1.30	508.0 20.00	29.2 1.15	2.97 6.6

QVP AND QVVP TWO-BOLT PILLOW BLOCKS – STRAIGHT BORE EQUIVALENT

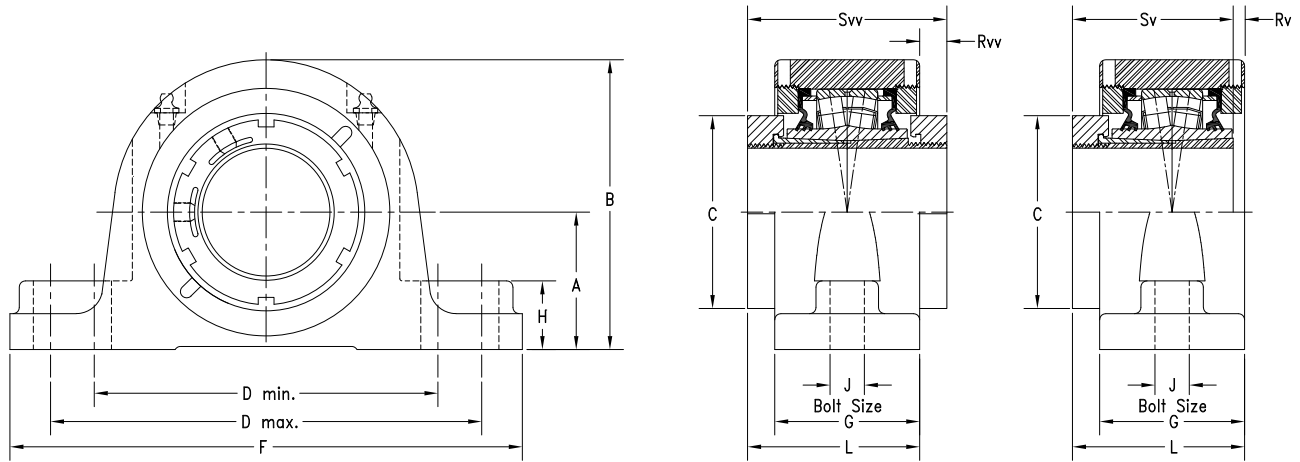

Bearing Part No. ⁽¹⁾⁽²⁾	Shaft Dia.	Bearing No.	A	B	C	D min.	D max.	F	G	H	J	L	Rv ⁽¹⁾	Rvv	Sv ⁽¹⁾	Svv	Wt.	
	mm in.		mm in.	mm in.	mm in.	mm in.	mm in.	mm in.	mm in.	mm in.	mm in.	mm in.	mm in.	mm in.	mm in.	mm in.	kg lbs.	
QVP11V115S QVVP11V115S	1 1/16 in.	22211	57.2	122.2	75.9	152.4	181.1	225.6	62.0	31.8	16	82.0	2.2	20.1	79.8	102.1	6.4	
QVP11V200S QVVP11V200S	2 in.		2.25	4.81	2.99	6.00	7.13	8.88	2.44	1.25	5/8	3.23	0.09	0.79	3.14	4.02	14	
QVP11V050S QVVP11V050S	50 mm																	
QVP12V203S QVVP12V203S	2 3/8 in.			63.5	133.4	80.3	165.1	200.2	244.6	66.8	31.8	16	84.6	4.7	17.8	79.8	102.1	7.7
QVP12V204S QVVP12V204S	2 1/4 in.	22212	2.50	5.25	3.16	6.50	7.88	9.63	2.63	1.25	5/8	3.33	0.18	0.70	3.14	4.02	17	
QVP12V055S QVVP12V055S	55 mm																	
QVP14V060S QVVP14V060S	60 mm																	
QVP14V207S QVVP14V207S	2 7/8 in.	22214	69.9	147.3	94.0	174.8	219.2	260.4	73.7	35.1	16	88.9	7.8	15.2	81.0	103.9	10.0	
QVP14V208S QVVP14V208S	2 1/2 in.		2.75	5.80	3.70	6.88	8.63	10.25	2.90	1.38	5/8	3.50	0.31	0.60	3.19	4.09	22	
QVP14V065S QVVP14V065S	65 mm																	
QVP16V211S QVVP16V211S	2 1/16 in.	22216	79.5	164.3	106.4	200.2	244.6	295.4	76.2	35.1	20	91.2	7.6	15.0	83.6	106.2	12.7	
QVP16V212S QVVP16V212S	2 3/4 in.																	
QVP16V070S QVVP16V070S	70 mm																	
QVP16V215S QVVP16V215S	2 15/16 in.																	
QVP16V300S QVVP16V300S	3 in.																	
QVP16V075S QVVP16V075S	75 mm																	

⁽¹⁾Bearing part numbers use QV to designate single-nut units (uses Rv and Sv dimensions) and QVV to designate double-nut units (uses Rvv and Svv dimensions).

⁽²⁾Single-nut (QV) part number shown. Double-nut (QVV) version available upon request.

QVP AND QVVP TWO-BOLT PILLOW BLOCKS – STRAIGHT BORE EQUIVALENT

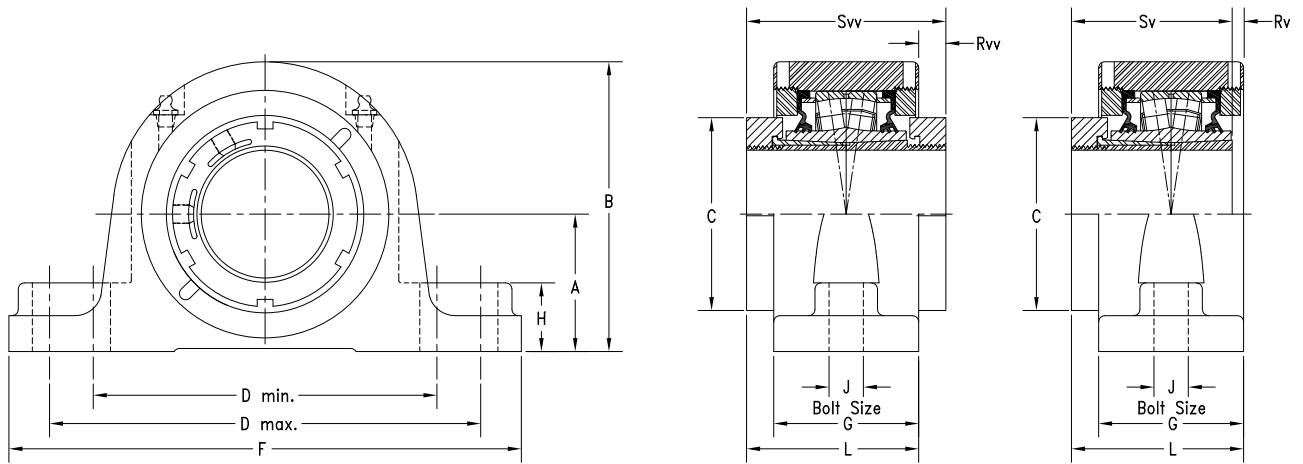

Bearing Part No. ⁽¹⁾⁽²⁾	Shaft Dia.	Bearing No.	A	B	C	D min.	D max.	F	G	H	J	L	Rv ⁽¹⁾	Rvv	Sv ⁽¹⁾	Svv	Wt.																
	mm in.		mm in.	mm in.	mm in.	mm in.	mm in.	mm in.	mm in.	mm in.	mm in.	mm in.	mm in.	mm in.	mm in.	mm in.	kg lbs.																
QVP19V303S QVVP19V303S	3 3/16 in.	22219	95.3	195.3	124.5	238.3	285.8	342.9	86.6	47.8	24	102.1	8.4	15.5	93.7	117.6	20.4																
QVP19V304S QVVP19V304S	3 1/4 in.																																
QVP19V080S QVVP19V080S	80 mm																																
QVP19V085S QVVP19V085S	85 mm																																
QVP19V307S QVVP19V307S	3 7/16 in.																																
QVP19V308S QVVP19V308S	3 1/2 in.																																
QVP19V090S QVVP19V090S	90 mm																																
QVP19V311S QVVP19V311S	3 11/16 in.																	22222	104.9	219.7	139.7	255.0	320.0	362.0	102.6	50.8	24	116.6	11.5	14.0	104.9	130.3	26.8
QVP19V312S QVVP19V312S	3 3/4 in.																																
QVP19V100S QVVP19V100S	100 mm																																
QVP19V315S QVVP19V315S	3 15/16 in.																																
QVP19V400S QVVP19V400S	4 in.																																

⁽¹⁾Bearing part numbers use QV to designate single-nut units (uses Rv and Sv dimensions) and QVV to designate double-nut units (uses Rvv and Svv dimensions).

⁽²⁾Single-nut (QV) part number shown. Double-nut (QVV) version available upon request.

QVPL AND QVVPL TWO-BOLT PILLOW BLOCKS – STRAIGHT BORE EQUIVALENT

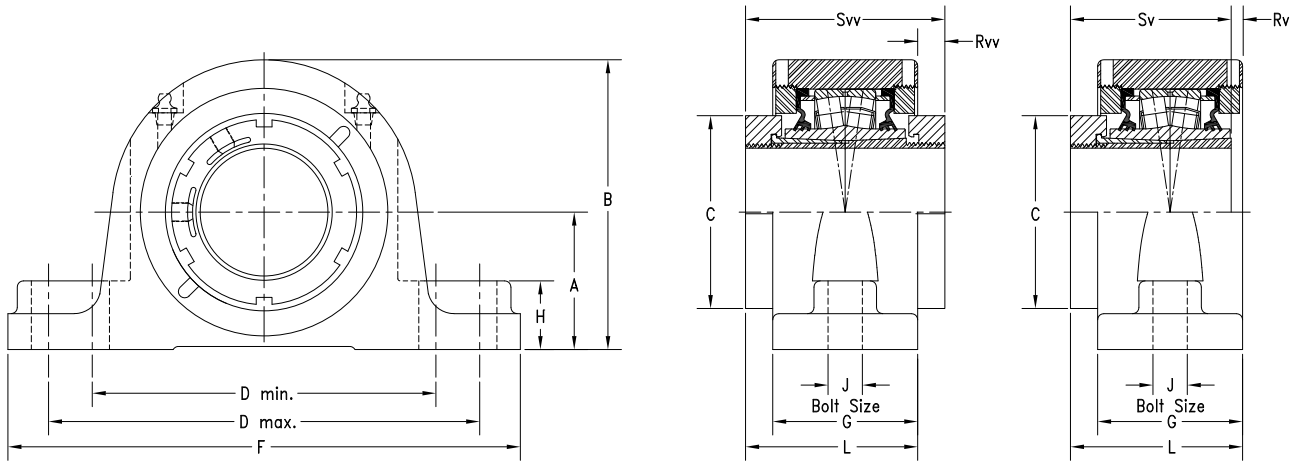

Bearing Part No. ⁽¹⁾⁽²⁾	Shaft Dia.	Bearing No.	A	B	C	D min.	D max.	F	G	H	J	L	Rv ⁽¹⁾	Rvv	Sv ⁽¹⁾	Svv	Wt.	
	mm in.		mm in.	mm in.	mm in.	mm in.	mm in.	mm in.	mm in.	mm in.	mm in.	mm in.	mm in.	mm in.	mm in.	mm in.	kg lbs.	
QVPL11V115S QVVPL11V115S	1 1/8 in.	22211	57.2	122.2	75.9	150.6	161.5	212.9	62.0	31.8	16	82.0	2.2	20.1	79.8	102.1	6.4	
QVPL11V200S QVVPL11V200S	2 in.		2.25	4.81	2.99	5.93	6.36	8.38	2.44	1.25	5/8	3.23	0.09	0.79	3.14	4.02	14	
QVPL11V050S QVVPL11V050S	50 mm																	
QVPL12V203S QVVPL12V203S	2 3/8 in.	22212	63.5	133.4	80.3	165.1	179.3	225.6	65.5	31.8	16	83.8	4.0	18.3	79.8	102.1	7.7	
QVPL12V204S QVVPL12V204S	2 1/4 in.		2.50	5.25	3.16	6.50	7.06	8.88	2.58	1.25	5/8	3.30	0.16	0.72	3.14	4.02	17	
QVPL12V055S QVVPL12V055S	55 mm																	
QVPL14V060S QVVPL14V060S	60 mm	22214	69.9	147.3	94.0	173	189.0	235.0	73.7	35.1	16	88.9	7.8	15.2	81.0	103.9	10.0	
QVPL14V207S QVVPL14V207S	2 7/8 in.		2.75	5.80	3.70	6.81	7.44	9.25	2.90	1.38	5/8	3.50	0.31	0.60	3.19	4.09	22	
QVPL14V208S QVVPL14V208S	2 1/2 in.																	
QVPL14V065S QVVPL14V065S	65 mm																	
QVPL16V211S QVVPL16V211S	2 1/8 in.	22216	82.6	167.4	106.4	195.6	213.4	265.2	76.2	35.1	20	91.2	7.6	15.0	83.6	106.2	12.7	
QVPL16V212S QVVPL16V212S	2 3/4 in.																	
QVPL16V070S QVVPL16V070S	70 mm																	
QVPL16V215S QVVPL16V215S	2 5/8 in.		3.25	6.59	4.19	7.70	8.40	10.44	3.00	1.38	3/4	3.59	0.30	0.59	3.29	4.18	28	
QVPL16V300S QVVPL16V300S	3 in.																	
QVPL16V075S QVVPL16V075S	75 mm																	

⁽¹⁾Bearing part numbers use QV to designate single-nut units (uses Rv and Sv dimensions) and QVV to designate double-nut units (uses Rvv and Svv dimensions).

⁽²⁾Single-nut (QV) part number shown. Double-nut (QVV) version available upon request.

QVPL AND QVVPL TWO-BOLT PILLOW BLOCKS – STRAIGHT BORE EQUIVALENT

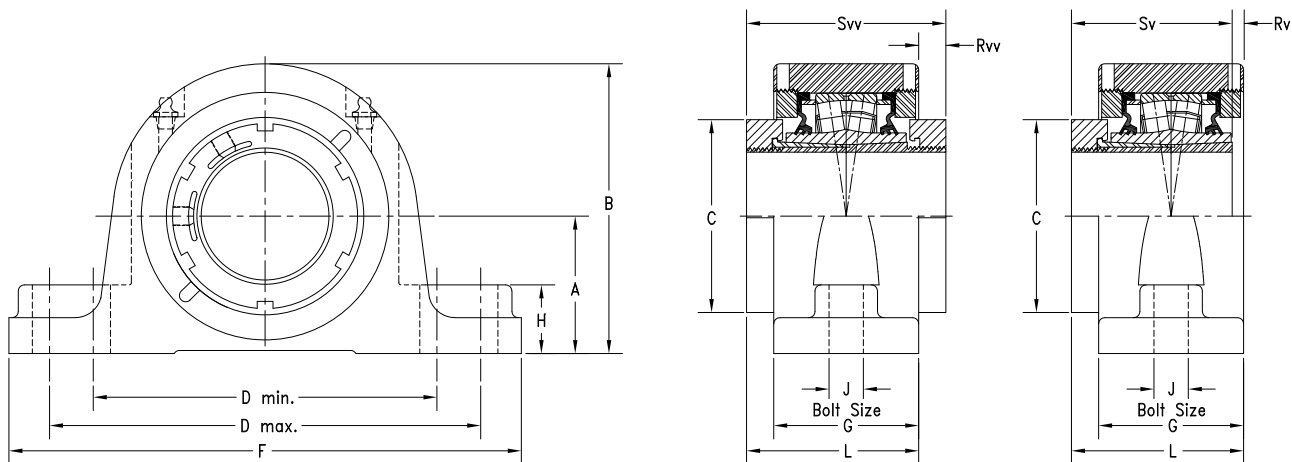

Bearing Part No. ⁽¹⁾⁽²⁾	Shaft Dia.	Bearing No.	A	B	C	D min.	D max.	F	G	H	J	L	Rv ⁽¹⁾	Rvv	Sv ⁽¹⁾	Svv	Wt.
	mm in.		mm in.	mm in.	mm in.	mm in.	mm in.	mm in.	mm in.	mm in.	mm in.	mm in.	mm in.	mm in.	mm in.	mm in.	kg lbs.
QVPL19V303S QVVPL19V303S	3 3/16 in.	22219	95.3	195.3	124.5	235.0	273.1	330.2	86.6	47.8	24	102.1	8.4	15.5	93.7	117.6	20.4
QVPL19V304S QVVPL19V304S	3 1/4 in.																
QVPL19V080S QVVPL19V080S	80 mm																
QVPL19V085S QVVPL19V085S	85 mm																
QVPL19V307S QVVPL19V307S	3 7/16 in.																
QVPL19V308S QVVPL19V308S	3 1/2 in.																
QVPL19V090S QVVPL19V090S	90 mm																
QVPL22V311S QVVPL22V311S	3 11/16 in.																
QVPL22V312S QVVPL22V312S	3 3/4 in.																
QVPL22V100S QVVPL22V100S	100 mm																
QVPL22V315S QVVPL22V315S	3 15/16 in.																
QVPL22V400S QVVPL22V400S	4 in.																

⁽¹⁾Bearing part numbers use QV to designate single-nut units (uses Rv and Sv dimensions) and QVV to designate double-nut units (uses Rvv and Svv dimensions).

⁽²⁾Single-nut (QV) part number shown. Double-nut (QVV) version available upon request.

QVPA AND QVVA SAF TWO-BOLT PILLOW BLOCKS – TAPERED BORE EQUIVALENT

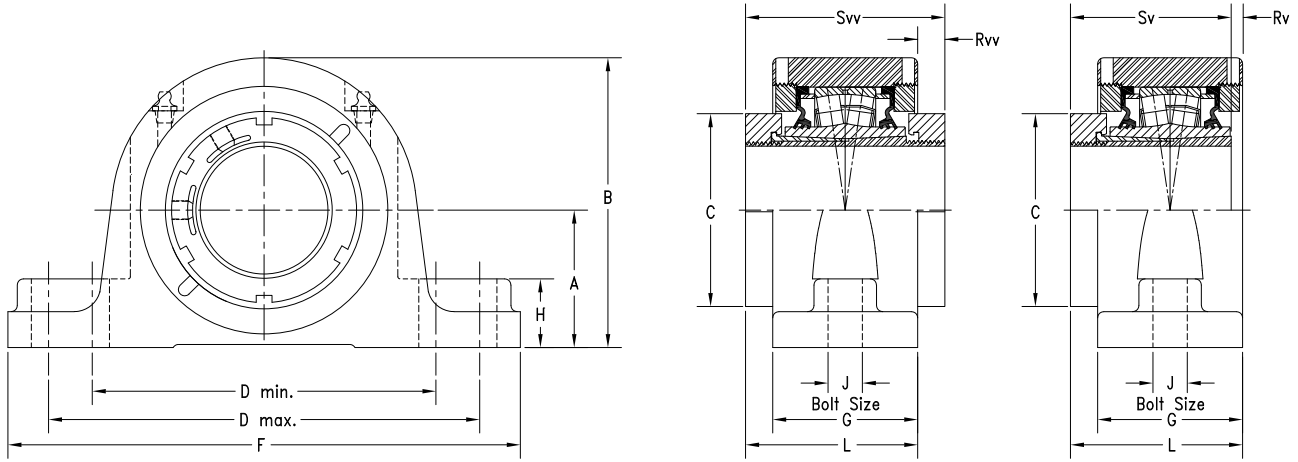

Bearing Part No. ⁽¹⁾⁽²⁾	Shaft Dia.	Bearing No.	A	B	C	D min.	D max.	F	G	H	J	L	Rv ⁽¹⁾	Rvv	Sv ⁽¹⁾	Svv	Wt.
	mm in.		mm in.	mm in.	mm in.	mm in.	mm in.	mm in.	mm in.	mm in.	mm in.	mm in.	mm in.	mm in.	mm in.	mm in.	kg lbs.
QVPA13V203S QVVA13V203S	2 3/8 in.	22213	76.2	151.1	80.3	182.9	241.3	269.5	68.6	31.2	16	85.3	2.8	16.8	85.3	102.1	10.4
QVPA13V204S QVVA13V204S	2 1/4 in.		3.00	5.95	3.16	7.20	9.50	10.61	2.70	1.23	5/8	3.36	0.11	0.66	3.36	4.02	23
QVPA13V055S QVVA13V055S	55 mm																
QVPA15V060S QVVA15V060S	60 mm	22215	82.6	163.3	94.0	200.2	244.6	276.4	68.6	31.8	16	86.4	3.6	17.8	82.6	103.9	12.2
QVPA15V207S QVVA15V207S	2 7/8 in.		3.25	6.43	3.70	7.88	9.63	10.88	2.70	1.25	5/8	3.40	0.14	0.70	3.25	4.09	27
QVPA15V208S QVVA15V208S	2 1/2 in.																
QVPA15V065S QVVA15V065S	65 mm																
QVPA16V211S QVVA16V211S	2 11/16 in.	22216	88.9	176.7	106.4	228.6	279.4	330.2	72.6	31.8	20	88.2	4.6	15.5	83.6	103.7	12.2
QVPA16V212S QVVA16V212S	2 3/4 in.		3.50	6.96	4.19	9.00	11.00	13.00	2.86	1.25	3/4	3.47	0.18	0.61	3.29	4.08	27
QVPA16V070S QVVA16V070S	70 mm																
QVPA17V211S QVVA17V211S	2 11/16 in.	22217	95.3	186	106.4	241.3	279.4	320.8	76.2	33.8	20	91.2	6.6	15.0	84.6	106.2	15.0
QVPA17V212S QVVA17V212S	2 3/4 in.																
QVPA17V070S QVVA17V070S	70 mm																
QVPA17V215S QVVA17V215S	2 15/16 in.																
QVPA17V300S QVVA17V300S	3 in.																
QVPA17V075S QVVA17V075S	75 mm																
QVPA19V303S QVVA19V303S	3 3/8 in.	22219	101.6	203.1	124.5	254.0	298.5	349.3	79.8	41.3	20	97.0	3.2	17.2	93.7	114.1	22.2
QVPA19V304S QVVA19V304S	3 1/4 in.		4.00	8.00	4.90	10.00	11.75	13.75	3.14	1.63	3/4	3.82	0.13	0.68	3.69	4.49	49
QVPA19V080S QVVA19V080S	80 mm																

⁽¹⁾Bearing part numbers use QV to designate single-nut units (uses Rv and Sv dimensions) and QVV to designate double-nut units (uses Rvv and Svv dimensions).

⁽²⁾Single-nut (QV) part number shown. Double-nut (QVV) version available upon request.

QVPA AND QVVA SAF TWO-BOLT PILLOW BLOCKS – TAPERED BORE EQUIVALENT

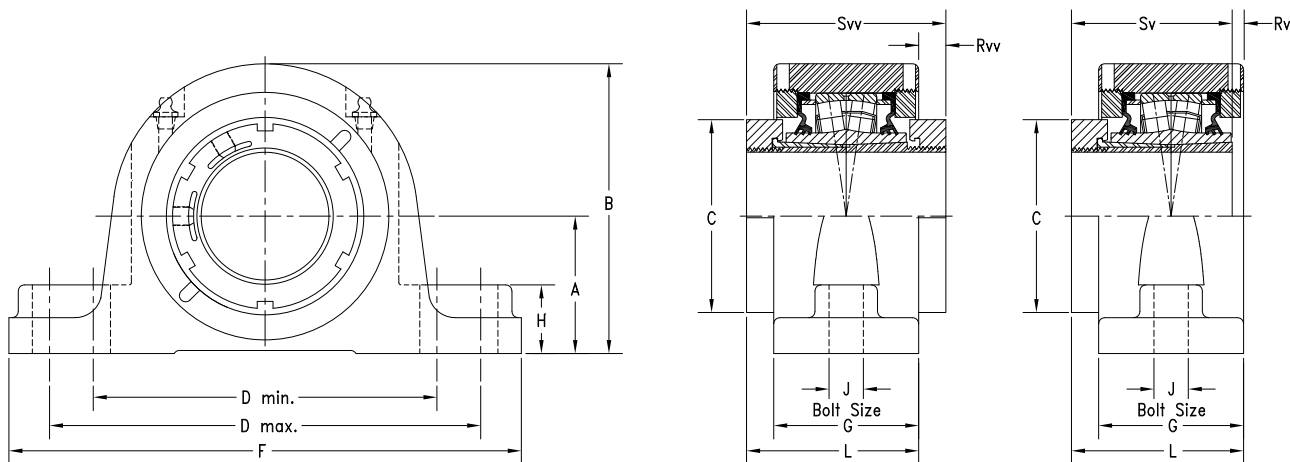

Bearing Part No. ⁽¹⁾⁽²⁾	Shaft Dia.	Bearing No.	A	B	C	D min.	D max.	F	G	H	J	L	Rv ⁽¹⁾	Rvv	Sv ⁽¹⁾	Svv	Wt.
	mm in.		mm in.	mm in.	mm in.	mm in.	mm in.	mm in.	mm in.	mm in.	mm in.	mm in.	mm in.	mm in.	mm in.	mm in.	kg lbs.
QVPA19V303S QVVA19V303S	3 3/8 in.	22220	114.3 4.50	219.2 8.63	124.5 4.90	276.4 10.88	333.5 13.13	374.7 14.75	86.9 3.42	41.4 1.63	24 7/8	102.4 4.03	6.8 0.27	15.5 0.61	95.3 3.75	117.6 4.63	29.5 65
QVPA19V304S QVVA19V304S	3 1/2 in.																
QVPA20V080S QVVA20V080S	80 mm																
QVPA20V085S QVVA20V085S	85 mm																
QVPA20V307S QVVA20V307S	3 7/8 in.																
QVPA20V308S QVVA20V308S	3 1/2 in.																
QVPA20V090S QVVA20V090S	90 mm																
QVPA22V311S QVVA22V311S	3 11/16 in.	22222	125.5 4.94	240.5 9.47	139.7 5.50	317.5 12.50	368.3 14.50	406.4 16.00	100.6 3.96	50.8 2.00	24 7/8	115.6 4.55	8.7 0.34	15.0 0.59	104.9 4.13	130.3 5.13	38.1 84
QVPA22V312S QVVA22V312S	3 3/4 in.																
QVPA22V100S QVVA22V100S	100 mm																
QVPA22V315S QVVA22V315S	3 15/16 in.																
QVPA22V400S QVVA22V400S	4 in.																
QVPA26V110S QVVA26V110S	110 mm	22226	152.4 6.00	284.0 11.18	174.8 6.88	162.0 14.25	400.1 15.75	444.5 17.50	128.0 5.04	51.8 2.04	24 1	143.2 5.64	6.0 0.24	35.2 1.39	147.8 5.82	178.3 7.02	61.7 136
QVPA26V407S QVVA26V407S	4 7/8 in.																
QVPA26V408S QVVA26V408S	4 1/2 in.																
QVPA26V115S QVVA26V115S	115 mm																
QVPA28V125S QVVA28V125S	125 mm	22228	152.4 6.00	297.2 11.70	190.0 7.48	384.3 15.13	441.5 17.38	499.9 19.68	108.0 4.25	51.8 2.04	30 1 1/4	132.0 5.20	4.7 0.18	46.5 1.83	147.8 5.82	178.3 7.02	61.8 136
QVPA28V415S QVVA28V415S	4 15/16 in.																
QVPA28V500S QVVA28V500S	5 in.																
QVPA28V130S QVVA28V130S	130 mm																

⁽¹⁾Bearing part numbers use QV to designate single-nut units (uses Rv and Sv dimensions) and QVV to designate double-nut units (uses Rvv and Svv dimensions).

⁽²⁾Single-nut (QV) part number shown. Double-nut (QVV) version available upon request.

QVPN AND QVVPN SN-STYLE TWO-BOLT PILLOW BLOCKS – TAPERED BORE EQUIVALENT

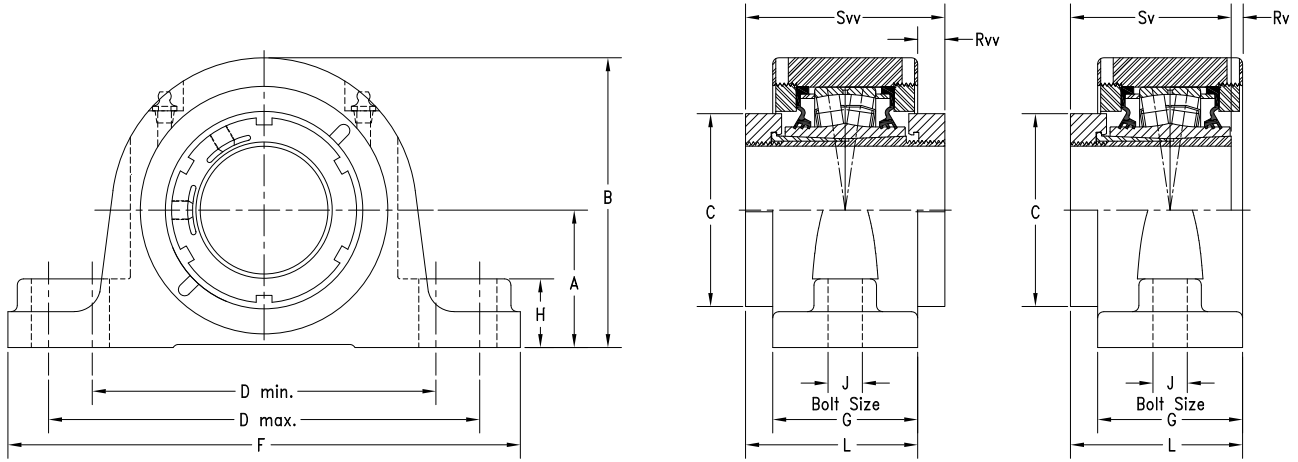

Bearing Part No. ⁽¹⁾⁽²⁾	Shaft Dia.	Bearing No.	A	B	C	D min.	D max.	F	G	H	J	L	Rv ⁽¹⁾	Rvv	Sv ⁽¹⁾	Svv	Wt.
	mm in.		mm in.	mm in.	mm in.	mm in.	mm in.	mm in.	mm in.	mm in.	mm in.	mm in.	mm in.	mm in.	mm in.	mm in.	kg lbs.
QVPN11V115S QVVPN11V115S	1 1/8 in.	22211	69.9	135.4	75.9	165.1	221.0	251.0	60.5	31.8	16	81.3	1.5	20.8	79.8	102.1	7.7
QVPN11V200S QVVPN11V200S	2 in.		2.75	5.33	2.99	6.50	8.70	9.88	2.38	1.25	5/8	3.20	0.06	0.82	3.14	4.02	17
QVPN11V050S QVVPN11V050S	50 mm	22212	70.0	140.5	80.0	177.8	219.2	254.0	60.5	31.8	16	81.3	1.5	20.8	79.8	102.1	9.1
QVPN12V055S QVVPN12V055S	55 mm		2.76	5.53	3.15	7.00	8.63	10.00	2.38	1.25	5/8	3.20	0.06	0.82	3.14	4.02	20
QVPN13V203S QVVPN13V203S	2 3/8 in.	22213	80.0	154.9	80.3	182.9	241.3	269.5	68.6	35.1	16	85.3	0.0	16.8	85.3	102.1	10.4
QVPN13V204S QVVPN13V204S	2 1/4 in.		3.15	6.10	3.16	7.20	9.50	10.61	2.70	1.38	5/8	3.36	0.0	0.66	3.36	4.02	23
QVPN14V060S QVVPN14V060S	60 mm	22214	80.0	157.5	94.0	195.6	235.0	275.0	74.0	35.1	16	89.0	6.6	15.0	81.0	104.0	10.4
			3.15	6.20	3.70	7.70	9.25	10.83	2.91	1.38	5/8	3.50	0.26	0.59	3.19	4.09	23
QVPN15V207S QVVPN15V207S	2 7/8 in.	22215	80.0	160.8	94.0	200.2	244.6	276.4	68.6	29.2	16	86.4	3.6	17.8	82.6	103.9	12.2
QVPN15V208S QVVPN15V208S	2 1/2 in.		3.15	6.33	3.70	7.88	9.63	10.88	2.70	1.15	5/8	3.40	0.14	0.70	3.25	4.09	27
QVPN15V065S QVVPN15V065S	65 mm	22216	95.0	180.3	106.4	235.0	266.7	315.0	72.6	31.8	20	89.4	4.6	16.8	83.6	106.0	13.6
QVPN16V211S QVVPN16V211S	2 1/8 in.		3.74	7.10	4.19	9.25	10.50	12.40	2.86	1.25	3/4	3.52	0.18	0.66	3.29	4.17	30
QVPN16V212S QVVPN16V212S	2 3/4 in.	22217	95.3	185.9	106.4	241.3	279.4	320.8	76.2	33.8	20	91.2	6.6	15.0	84.6	106.2	15.0
QVPN16V070S QVVPN16V070S	70 mm		3.75	7.32	4.19	9.50	11.00	12.63	3.00	1.33	3/4	3.59	0.26	0.59	3.33	4.18	33
QVPN17V215S QVVPN17V215S	2 1/8 in.	22219	100.0	195.3	124.5	285.8	295.4	344.9	86.6	38.9	20	102.0	6.4	16.0	93.7	118.1	22.2
QVPN17V300S QVVPN17V300S	3 in.		3.94	7.69	4.90	11.25	11.63	13.58	3.41	1.53	3/4	4.02	0.25	0.63	3.69	4.65	49
QVPN17V075S QVVPN17V075S	75 mm	22219	112.0	212.3	124.5	285.8	295.4	346.2	82.8	38.9	20	100.6	4.7	17.8	93.7	118.1	23.1
QVPN19V303S QVVPN19V303S	3 3/8 in.		4.41	8.36	4.90	11.25	11.63	13.63	3.26	1.53	3/4	3.96	0.19	0.70	3.69	4.65	51
QVPN19V304S QVVPN19V304S	3 1/4 in.	22219	112.0	212.3	124.5	285.8	295.4	346.2	82.8	38.9	20	100.6	4.7	17.8	93.7	118.1	23.1
QVPN19V080S QVVPN19V080S	80 mm		4.41	8.36	4.90	11.25	11.63	13.63	3.26	1.53	3/4	3.96	0.19	0.70	3.69	4.65	51
QVPN19V085S QVVPN19V085S	85 mm	22219	112.0	212.3	124.5	285.8	295.4	346.2	82.8	38.9	20	100.6	4.7	17.8	93.7	118.1	23.1
			4.41	8.36	4.90	11.25	11.63	13.63	3.26	1.53	3/4	3.96	0.19	0.70	3.69	4.65	51

⁽¹⁾Bearing part numbers use QV to designate single-nut units (uses Rv and Sv dimensions) and QVV to designate double-nut units (uses Rvv and Svv dimensions).

⁽²⁾Single-nut (QV) part number shown. Double-nut (QVV) version available upon request.

QVPN AND QVVPN SN-STYLE TWO-BOLT PILLOW BLOCKS – TAPERED BORE EQUIVALENT

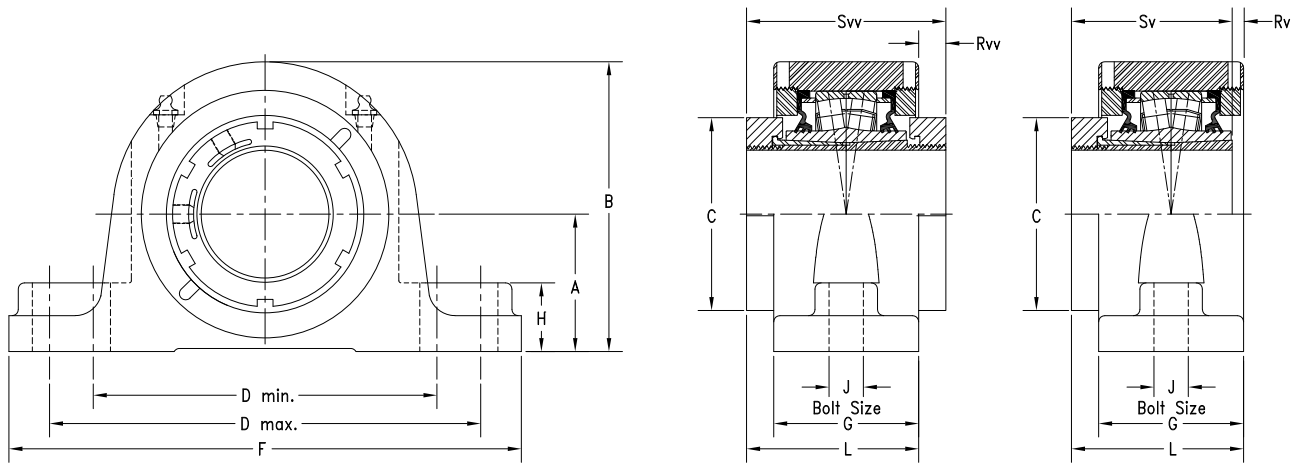

Bearing Part No. ⁽¹⁾⁽²⁾	Shaft Dia.	Bearing No.	A	B	C	D min.	D max.	F	G	H	J	L	Rv ⁽¹⁾	Rvv	Sv ⁽¹⁾	Svv	Wt.
			mm in.	mm in.	mm in.	mm in.	mm in.	mm in.	mm in.	mm in.	mm in.	mm in.	mm in.	mm in.	mm in.	mm in.	mm in.
QVPN20V307S QVVPN20V307S	3 7/16 in.	22220	112.0 4.41	216.9 8.54	124.5 4.90	276.4 10.88	333.5 13.13	374.7 14.75	86.9 3.42	38.9 1.53	24 7/8	102.4 4.03	6.8 0.27	15.5 0.61	95.3 3.75	117.6 4.63	29.5 65
QVPN20V308S QVVPN20V308S	3 1/2 in.																
QVPN20V090S QVVPN20V090S	90 mm	22222	125.5 4.94	240.5 9.47	139.7 5.50	317.5 12.50	368.3 14.50	406.4 16.00	100.6 3.96	50.8 2.00	24 7/8	115.6 4.55	8.7 0.34	15.0 0.59	104.9 4.13	130.3 5.13	38.1 84
QVPN22V311S QVVPN22V311S	3 11/16 in.																
QVPN22V312S QVVPN22V312S	3 3/4 in.	22224	140.0 5.51	262.9 10.35	174.8 6.88	344.4 13.56	355.6 14.00	409.7 16.13	97.8 3.85	50.8 2.00	24 7/8	138.2 5.44	9.8 0.38	40.4 1.59	147.8 5.82	178.3 7.02	49.9 110
QVPN22V100S QVVPN22V100S	100 mm																
QVPN22V315S QVVPN22V315S	3 15/16 in.	22226	150.0 5.91	281.7 11.09	174.8 6.88	362.0 14.25	400.1 15.75	444.5 17.50	128.0 5.04	49.3 1.94	24 1	153.2 6.03	6.0 0.24	25.1 0.99	147.8 5.82	178.3 7.02	61.7 136
QVPN26V407S QVVPN26V407S	4 7/16 in.																
QVPN26V408S QVVPN26V408S	4 1/2 in.	22228	150.0 5.91	394.9 11.61	190.0 7.48	384.3 15.13	441.5 17.38	423.9 16.69	108.0 4.25	49.5 1.95	30 1 1/4	132.0 5.20	4.7 0.18	46.5 1.83	147.8 5.82	178.3 7.02	63.0 138
QVPN26V115S QVVPN26V115S	115 mm																
QVPN28V125S QVVPN28V125S	125 mm	22228	150.0 5.91	394.9 11.61	190.0 7.48	384.3 15.13	441.5 17.38	423.9 16.69	108.0 4.25	49.5 1.95	30 1 1/4	132.0 5.20	4.7 0.18	46.5 1.83	147.8 5.82	178.3 7.02	63.0 138
QVPN28V415S QVVPN28V415S	4 15/16 in.																
QVPN28V500S QVVPN28V500S	5 in.	22228	150.0 5.91	394.9 11.61	190.0 7.48	384.3 15.13	441.5 17.38	423.9 16.69	108.0 4.25	49.5 1.95	30 1 1/4	132.0 5.20	4.7 0.18	46.5 1.83	147.8 5.82	178.3 7.02	63.0 138
QVPN28V130S QVVPN28V130S	130 mm																

⁽¹⁾Bearing part numbers use QV to designate single-nut units (uses Rv and Sv dimensions) and QVV to designate double-nut units (uses Rvv and Sv dimensions).

⁽²⁾Single-nut (QV) part number shown. Double-nut (QVV) version available upon request.

QVSN AND QVSN SN-STYLE TWO-BOLT PILLOW BLOCKS – PURE METRIC DESIGN

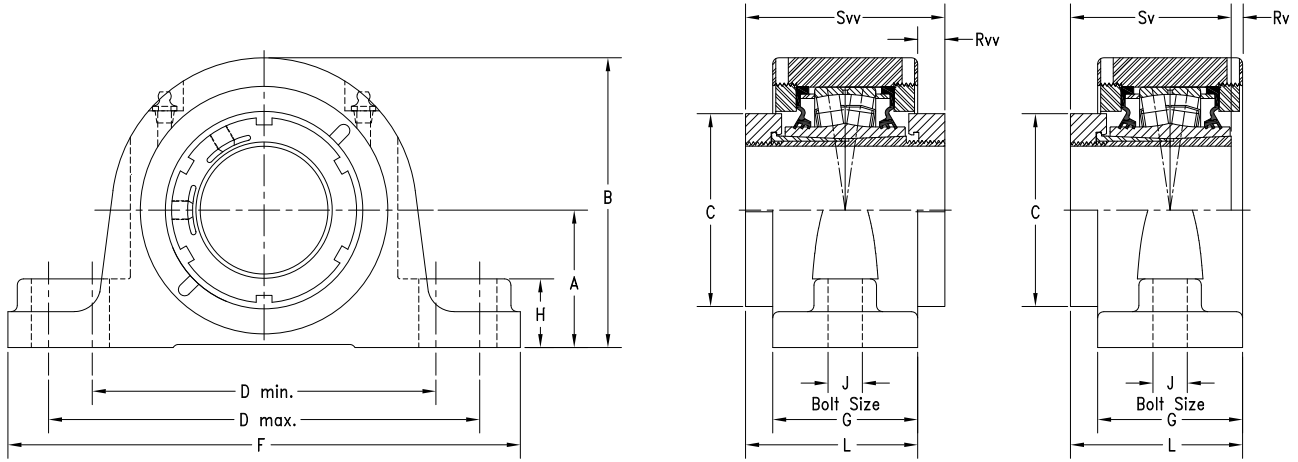

Bearing Part No. ⁽¹⁾⁽²⁾	Shaft Dia.	Bearing No.	A	B	C	D min.	D max.	F	G	H	J	L	Rv ⁽¹⁾	Rvv	Sv ⁽¹⁾	Svv	Wt.	
	mm in.		mm in.	mm in.	mm in.	mm in.	mm in.	mm in.	mm in.	mm in.	mm in.	mm in.	mm in.	mm in.	mm in.	mm in.	kg lbs.	
QVSN11V115S	1 1/8 in.	22211	70	136	76	183	216	254	68	25	16	85	5.3	17	79.8	102	8.4	
QVSN11V200S	2 in.		2.76	5.35	2.99	7.20	8.50	10.00	2.68	0.98	5/8	3.35	0.21	0.67	3.14	4.02	18	
QVSN11V050S	50 mm																	
QVSN12V203S	2 3/8 in.	22212	70	141	80	183	216	254	68	25	16	85	5.3	17	79.8	102	13.2	
QVSN12V204S	2 1/4 in.		2.76	5.54	3.16	7.20	8.50	10.00	2.69	0.98	5/8	3.35	0.21	0.67	3.14	4.02	29	
QVSN12V055S	55 mm																	
QVSN14V060S	60 mm	22214	80	157	94	196	235	275	74	35	16	89	6.6	15	81.0	104	16.8	
QVSN14V207S	2 7/8 in.		3.15	6.20	3.70	7.70	9.25	10.83	2.91	1.38	5/8	3.50	0.26	0.59	3.19	4.09	37	
QVSN14V208S	2 1/2 in.																	
QVSN14V065S	65 mm																	
QVSN16V211S	2 1/8 in.	22216	95	183	106	241	279	316	76	34	20	91	6.2	15	83.6	106	20.9	
QVSN16V212S	2 3/4 in.		3.74	7.19	4.19	9.50	11	12.44	3.00	1.32	3/4	3.58	0.24	0.59	3.29	4.17	46	
QVSN16V070S	70 mm																	
QVSN16V215S	2 1/8 in.																	
QVSN16V300S	3 in.																	
QVSN16V075S	75 mm																	
QVSN19V303S	3 3/8 in.	22219	100	200	124	280	292	345	86	39	20	102	6.4	16	93.7	118	25.4	
QVSN19V304S	3 1/4 in.		3.94	7.87	4.90	11.02	11.50	13.58	3.38	1.53	3/4	4.02	0.25	0.63	3.69	4.65	56	
QVSN19V080S	80 mm																	
QVSN19V085S	85 mm	22219	112	212	124	280	292	345	86	39	20	102	6.4	16	93.7	118	25.4	
			4.41	8.34	4.90	11.02	11.50	13.58	3.38	1.53	3/4	4.02	0.25	0.63	3.69	4.65	56	

⁽¹⁾Bearing part numbers use QV to designate single-nut units (uses Rv and Sv dimensions) and QVV to designate double-nut units (uses Rvv and Svv dimensions).

⁽²⁾Single-nut (QV) part number shown. Double-nut (QVV) version available upon request.

QVSN AND QVVSN SN-STYLE TWO-BOLT PILLOW BLOCKS – PURE METRIC DESIGN

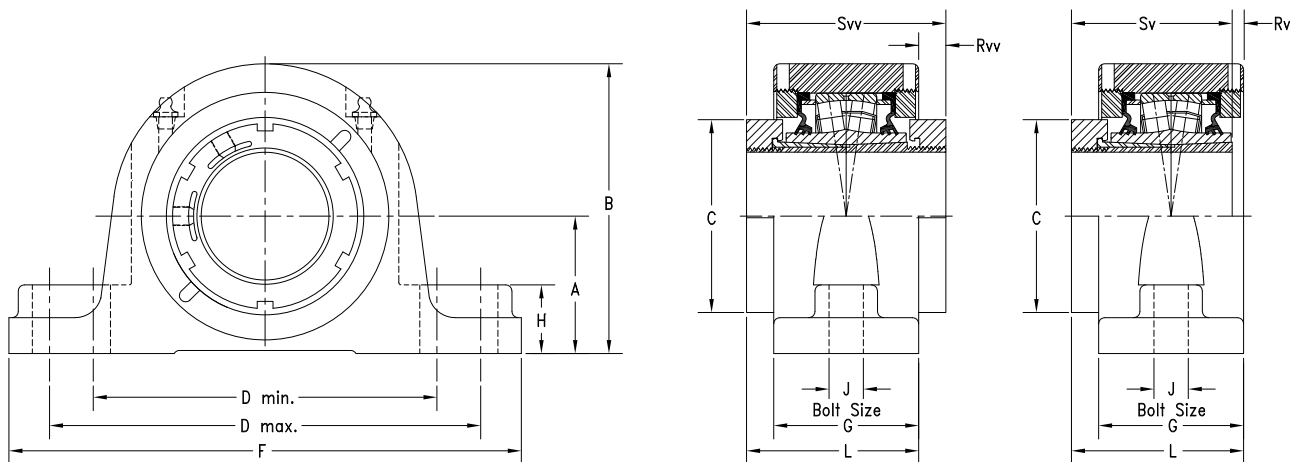

Bearing Part No. ⁽¹⁾⁽²⁾	Shaft Dia.	Bearing No.	A	B	C	D min.	D max.	F	G	H	J	L	Rv ⁽¹⁾	Rvv	Sv ⁽¹⁾	SvV	Wt.
	mm in.		mm in.	mm in.	mm in.	mm in.	mm in.	mm in.	mm in.	mm in.	mm in.	mm in.	mm in.	mm in.	mm in.	mm in.	kg lbs.
QVVSN19V307S	3 3/16 in.	22219	112	212	124	290	327	380	86	39	24	102	6.4	16	93.7	118	25.4
QVVSN19V308S	3 1/2 in.		4.41	8.34	4.90	11.42	12.87	14.96	3.38	1.53	7/8	4.02	0.25	0.63	3.69	4.65	56
QVVSN19V090S	90 mm																
QVVSN22V311S	3 11/16 in.	22222	125	241	140	320	366	410	101	50	24	116	8.8	15	104.9	130	35.8
QVVSN22V312S	3 3/4 in.																
QVVSN22V100S	100 mm																
QVVSN22V315S	3 15/16 in.																
QVVSN22V400S	4 in.																
QVVSN26V110S	110 mm	22226	140 5.51	270 10.63	175 6.88	332 13.08	365 14.37	410 16.14	113 4.43	39 1.55	24 7/8	146 5.75	2.0 0.08	33 1.30	147.8 5.82	178 7.01	39.9 88
QVVSN26V407S	4 7/16 in.	22226	150	279	175	367	400	445	113	49	24	146	2.4	33	147.8	178	39.9
QVVSN26V408S	4 1/2 in.																
QVVSN26V115S	115 mm																
QVVSN28V125S	125 mm	22228	150	294	190	402	435	500	116	49	30	148	0.7	31	147.8	178	67.0
QVVSN28V415S	4 15/16 in.																
QVVSN28V500S	5 in.																
QVVSN28V130S	130 mm																

⁽¹⁾Bearing part numbers use QV to designate single-nut units (uses Rv and Sv dimensions) and QVV to designate double-nut units (uses Rvv and SvV dimensions).

⁽²⁾Single-nut (QV) part number shown. Double-nut (QVV) version available upon request.

QVPKT AND QVVPKT 9000 SERIES TWO-BOLT PILLOW BLOCKS – TAPERED BORE EQUIVALENT

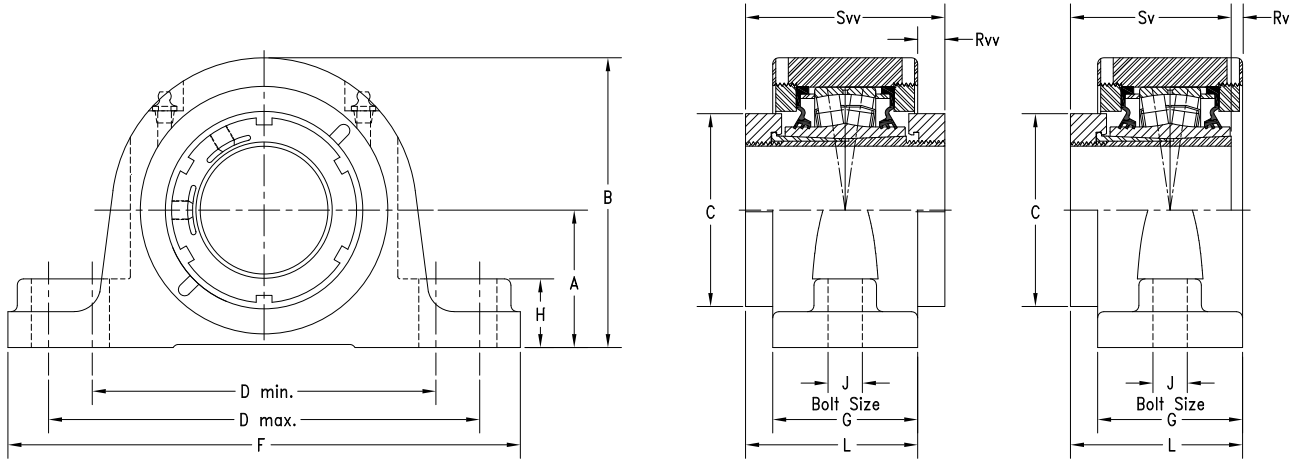

Bearing Part No. ⁽¹⁾⁽²⁾	Shaft Dia.	Bearing No.	A	B	C	D min.	D max.	F	G	H	J	L	Rv ⁽¹⁾	Rvv	Sv ⁽¹⁾	Svv	Wt.	
	mm in.		mm in.	mm in.	mm in.	mm in.	mm in.	mm in.	mm in.	mm in.	mm in.	mm in.	mm in.	mm in.	mm in.	mm in.	kg lbs.	
QVPKT13V203S QVVPKT13V203S	2 3/16 in.	22213	76.2	153.7	80.3	194.6	223.0	285.8	73.7	35.1	20	87.9	2.6	14.2	85.3	102.1	10.0	
QVPKT13V204S QVVPKT13V204S	2 1/4 in.		3.00	6.05	3.16	7.66	8.78	11.25	2.90	1.38	3/4	3.46	0.10	0.56	3.36	4.02	22	
QVPKT13V055S QVVPKT13V055S	55 mm																	
QVPKT15V060S QVVPKT15V060S	60 mm																	
QVPKT15V207S QVVPKT15V207S	2 7/16 in.	22215	88.9	173.7	94.0	230.1	265.2	330.2	75.7	35.1	24	89.9	7.2	14.2	82.6	103.9	12.7	
QVPKT15V208S QVVPKT15V208S	2 1/2 in.		3.50	6.84	3.70	9.06	10.44	13.00	2.98	1.38	7/8	3.54	0.28	0.56	3.25	4.09	28	
QVPKT15V065S QVVPKT15V065S	65 mm																	

⁽¹⁾Bearing part numbers use QV to designate single-nut units (uses Rv and Sv dimensions) and QVV to designate double-nut units (uses Rvv and Svv dimensions).
⁽²⁾Single-nut (QV) part number shown. Double-nut (QVV) version available upon request.

QVPF AND QVVPF FOUR-BOLT PILLOW BLOCKS – STRAIGHT BORE EQUIVALENT

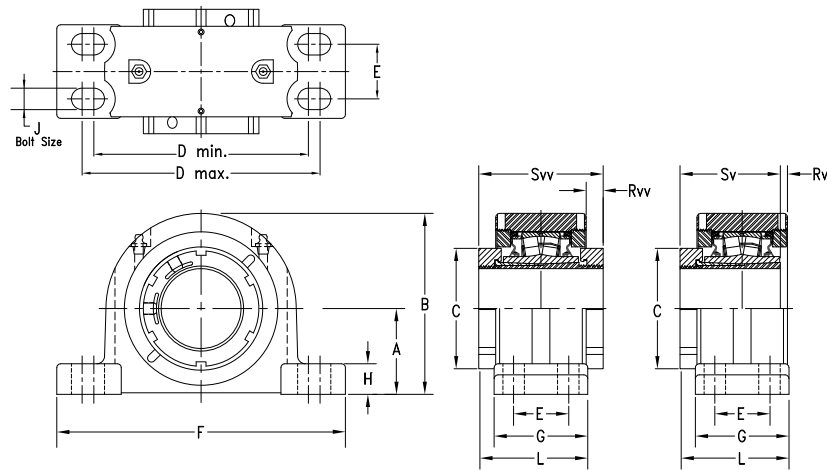

Bearing Part No. ⁽¹⁾⁽²⁾	Shaft Dia.	Bearing No.	A	B	C	D min.	D max.	E	F	G	H	J	L	Rv ⁽¹⁾	Rvv	Sv ⁽¹⁾	Svv	Wt.	
	mm in.		mm in.	mm in.	mm in.	mm in.	mm in.	mm in.	mm in.	mm in.	mm in.	mm in.	mm in.	mm in.	mm in.	mm in.	mm in.	kg lbs.	
QVPF14V060S QVVPF14V060S	60 mm	22214	69.9 2.75	147.3 5.80	94.0 3.70	174.8 6.88	193.8 7.63	44.5 1.75	235.0 9.25	76.2 3.00	24.9 0.98	16 5/8	90.2 3.55	6.5 0.26	15.2 0.60	81.0 3.19	103.9 4.09	9.1 20	
QVPF14V207S QVVPF14V207S	2 7/16 in.																		
QVPF14V208S QVVPF14V208S	2 1/2 in.																		
QVPF14V065S QVVPF14V065S	65 mm																		
QVPF16V211S QVVPF16V211S	2 1/16 in.	22216	82.6 3.25	167.4 6.59	106.4 4.19	193.0 7.60	231.1 9.10	47.8 1.88	265.2 10.44	79.5 3.13	32.8 1.29	16 5/8	93.0 3.66	6.1 0.24	15.2 0.60	83.6 3.29	106.2 4.18	12.2 27	
QVPF16V212S QVVPF16V212S	2 3/4 in.																		
QVPF16V070S QVVPF16V070S	70 mm																		
QVPF16V215S QVVPF16V215S	2 15/16 in.																		
QVPF16V300S QVVPF16V300S	3 in.	22219	95.3 3.75	195.3 7.69	124.5 4.90	225.6 8.88	276.4 10.88	50.8 2.00	312.4 12.30	95.3 3.75	39.6 1.56	20 3/4	106.4 4.19	7.8 0.31	14.5 0.57	93.7 3.69	117.6 4.63	22.2 49	
QVPF16V075S QVVPF16V075S	75 mm																		
QVPF19V303S QVVPF19V303S	3 3/16 in.																		
QVPF19V304S QVVPF19V304S	3 1/4 in.																		
QVPF19V080S QVVPF19V080S	80 mm	22219	95.3 3.75	195.3 7.69	124.5 4.90	225.6 8.88	276.4 10.88	50.8 2.00	312.4 12.30	95.3 3.75	39.6 1.56	20 3/4	106.4 4.19	7.8 0.31	14.5 0.57	93.7 3.69	117.6 4.63	22.2 49	
QVPF19V085S QVVPF19V085S	85 mm																		
QVPF19V307S QVVPF19V307S	3 7/16 in.																		
QVPF19V308S QVVPF19V308S	3 1/2 in.																		
QVPF19V090S QVVPF19V090S	90 mm																		

⁽¹⁾Bearing part numbers use QV to designate single-nut units (uses Rv and Sv dimensions) and QVV to designate double-nut units (uses Rvv and Svv dimensions).

⁽²⁾Single-nut (QV) part number shown. Double-nut (QVV) version available upon request.

Continued on next page.

QVPF AND QVVPF FOUR-BOLT PILLOW BLOCKS – STRAIGHT BORE EQUIVALENT

– continued

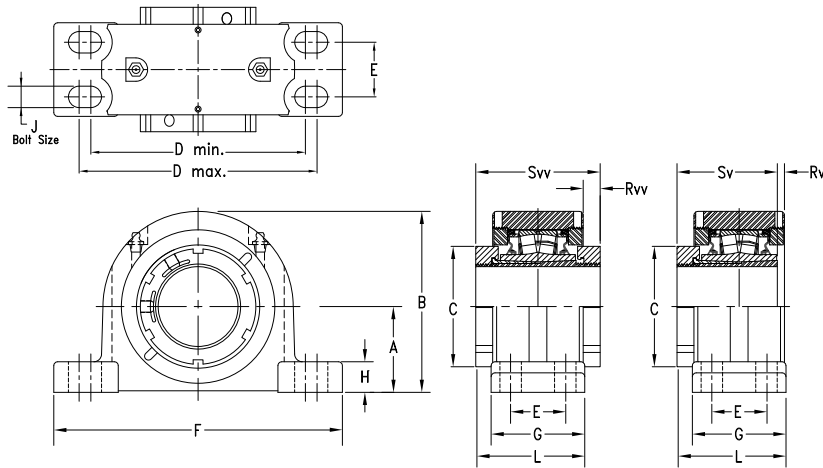

Bearing Part No. ⁽¹⁾⁽²⁾	Shaft Dia.	Bearing No.	A	B	C	D min.	D max.	E	F	G	H	J	L	Rv ⁽¹⁾	Rvv	Sv ⁽¹⁾	Svv	Wt.
	mm in.		mm in.	mm in.	mm in.	mm in.	mm in.	mm in.	mm in.	mm in.	mm in.	mm in.	mm in.	mm in.	mm in.	mm in.	mm in.	kg lbs.
QVPF22V311S QVVPF22V311S	3 1/16 in.	22222	108.0 4.25	223.0 8.78	139.7 5.50	276.4 10.88	339.9 13.38	57.2 2.25	378.0 14.88	109.5 4.31	35.6 1.40	20 3/4	119.9 4.72	8.8 0.35	14.7 0.58	104.9 4.13	130.3 5.13	30.4 67
QVPF22V312S QVVPF22V312S	3 3/4 in.																	
QVPF22V100S QVVPF22V100S	100 mm																	
QVPF22V315S QVVPF22V315S	3 15/16 in.																	
QVPF22V400S QVVPF22V400S	4 in.																	
QVPF26V110S QVVPF26V110S	110 mm																	
QVPF26V407S QVVPF26V407S	4 7/16 in.																	
QVPF26V408S QVVPF26V408S	4 1/2 in.																	
QVPF26V115S QVVPF26V115S	115 mm																	
QVPF28V125S QVVPF28V125S	125 mm	22228	139.7 5.50	279.7 11.01	190.0 7.48	349.3 13.75	403.4 15.88	69.9 2.75	444.5 17.50	128.0 5.04	39.1 1.54	24 7/8	153.2 6.03	1.0 0.04	31.5 1.24	147.8 5.82	178.3 7.02	60.8 134
QVPF28V415S QVVPF28V415S	4 15/16 in.																	
QVPF28V500S QVVPF28V500S	5 in.																	
QVPF28V130S QVVPF28V130S	130 mm																	

⁽¹⁾Bearing part numbers use QV to designate single-nut units (uses Rv and Sv dimensions) and QVV to designate double-nut units (uses Rvv and Svv dimensions).

⁽²⁾Single-nut (QV) part number shown. Double-nut (QVV) version available upon request.

QVPR AND QVVPR FOUR-BOLT PILLOW BLOCKS – STRAIGHT BORE EQUIVALENT

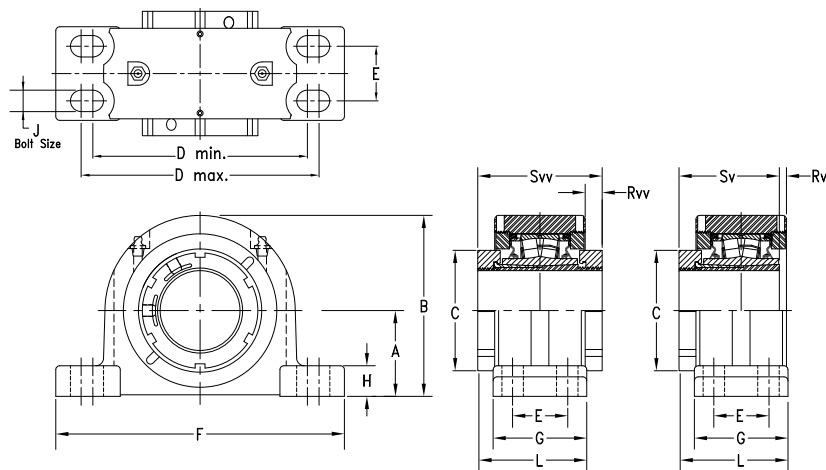

Bearing Part No. ⁽¹⁾⁽²⁾	Shaft Dia.	Bearing No.	A	B	C	D min.	D max.	E	F	G	H	J	L	Rv ⁽¹⁾	Rvv	Sv ⁽¹⁾	Svv	Wt.	
	mm in.		mm in.	mm in.	mm in.	mm in.	mm in.	mm in.	mm in.	mm in.	mm in.	mm in.	mm in.	mm in.	mm in.	mm in.	mm in.	kg lbs.	
QVPR14V060S QVVPR14V060S	60 mm	22214	69.9 2.75	147.3 5.80	94.0 3.70	181.1 7.13	222.2 8.75	47.8 1.88	260.4 10.25	82.6 3.25	24.9 0.98	16 5/8	93.2 3.67	6.5 0.26	15.2 0.60	81.0 3.19	103.9 4.09	9.1 20	
QVPR14V207S QVVPR14V207S	2 7/16 in.																		
QVPR14V208S QVVPR14V208S	2 1/2 in.																		
QVPR14V065S QVVPR14V065S	65 mm																		
QVPR16V211S QVVPR16V211S	2 1/16 in.	22216	79.5 3.13	164.3 6.47	106.4 4.19	203.2 8.00	243.8 9.60	54.1 2.13	275.1 10.83	85.9 3.38	29.5 1.16	16 5/8	96.0 3.78	6.1 0.24	15.2 0.60	83.6 3.29	106.2 4.18	12.2 27	
QVPR16V212S QVVPR16V212S	2 3/4 in.																		
QVPR16V070S QVVPR16V070S	70 mm																		
QVPR16V215S QVVPR16V215S	2 15/16 in.																		
QVPR16V300S QVVPR16V300S	3 in.	22219	95.3 3.75	195.3 7.69	124.5 4.90	235.0 9.25	285.8 11.25	60.5 2.38	346.2 13.63	95.3 3.75	39.6 1.56	20 3/4	106.4 4.19	7.8 0.31	14.5 0.57	93.7 3.69	117.6 4.63	22.2 49	
QVPR16V075S QVVPR16V075S	75 mm																		
QVPR19V303S QVVPR19V303S	3 3/16 in.																		
QVPR19V304S QVVPR19V304S	3 1/4 in.																		
QVPR19V080S QVVPR19V080S	80 mm	22219	95.3 3.75	195.3 7.69	124.5 4.90	235.0 9.25	285.8 11.25	60.5 2.38	346.2 13.63	95.3 3.75	39.6 1.56	20 3/4	106.4 4.19	7.8 0.31	14.5 0.57	93.7 3.69	117.6 4.63	22.2 49	
QVPR19V085S QVVPR19V085S	85 mm																		
QVPR19V307S QVVPR19V307S	3 7/16 in.																		
QVPR19V308S QVVPR19V308S	3 1/2 in.																		
QVPR19V090S QVVPR19V090S	90 mm																		

⁽¹⁾Bearing part numbers use QV to designate single-nut units (uses Rv and Sv dimensions) and QVV to designate double-nut units (uses Rvv and Svv dimensions).

⁽²⁾Single-nut (QV) part number shown. Double-nut (QVV) version available upon request.

QVPX AND QVVPX 5000 SERIES FOUR-BOLT PILLOW BLOCKS – STRAIGHT BORE EQUIVALENT

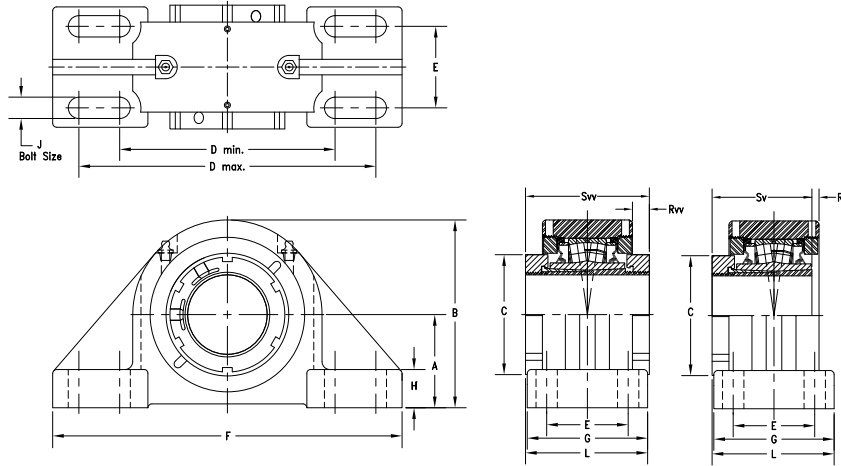

Bearing Part No. ⁽¹⁾⁽²⁾	Shaft Dia.	Bearing No.	A	B	C	D min.	D max.	E	F	G	H	J	L	Rv ⁽¹⁾	Rvv	Sv ⁽¹⁾	Svv	Wt.
	mm in.		mm in.	mm in.	mm in.	mm in.	mm in.	mm in.	mm in.	mm in.	mm in.	mm in.	mm in.	mm in.	mm in.	mm in.	mm in.	kg lbs.
QVPX14V060S QVVPX14V060S	60 mm	22214	76.2 3.00	153.7 6.05	94.0 3.70	176.3 6.94	242.8 9.56	66.8 2.63	285.8 11.25	98.6 3.88	31.0 1.23	16 5/8	101.3 3.99	6.5 0.26	15.2 0.60	81.0 3.19	103.9 4.09	10.4 23
QVPX14V207S QVVPX14V207S	2 7/16 in.																	
QVPX14V208S QVVPX14V208S	2 1/2 in.																	
QVPX14V065S QVVPX14V065S	65 mm																	
QVPX16V211S QVVPX16V211S	2 1 1/16 in.	22216	88.9 3.50	173.5 6.83	106.4 4.19	230.1 9.06	265.2 10.44	69.9 2.75	330.2 13.00	108.0 4.25	39.1 1.54	20 3/4	107.2 4.22	7.2 0.28	14.2 0.56	83.6 3.29	106.2 4.18	12.7 28
QVPX16V212S QVVPX16V212S	2 3/4 in.																	
QVPX16V070S QVVPX16V070S	70 mm																	
QVPX16V215S QVVPX16V215S	2 1 5/16 in.																	
QVPX16V300S QVVPX16V300S	3 in.	22219	101.6 4.00	201.2 7.92	124.5 4.90	274.6 10.81	309.6 12.19	76.2 3.00	381.0 15.00	120.7 4.75	38.1 1.50	20 3/4	119.1 4.69	7.8 0.31	14.5 0.57	93.7 3.69	117. 4.63	22.2 49
QVPX16V075S QVVPX16V075S	75 mm																	
QVPX19V303S QVVPX19V303S	3 3/16 in.																	
QVPX19V304S QVVPX19V304S	3 1/4 in.																	
QVPX19V080S QVVPX19V080S	80 mm																	
QVPX19V085S QVVPX19V085S	85 mm																	
QVPX19V307S QVVPX19V307S	3 7/16 in.																	
QVPX19V308S QVVPX19V308S	3 1/2 in.																	
QVPX19V090S QVVPX19V090S	90 mm																	

⁽¹⁾Bearing part numbers use QV to designate single-nut units (uses Rv and Sv dimensions) and QVV to designate double-nut units (uses Rvv and Svv dimensions).

⁽²⁾Single-nut (QV) part number shown. Double-nut (QVV) version available upon request.

QVPX AND QVVPX 5000 SERIES FOUR-BOLT PILLOW BLOCKS – STRAIGHT BORE EQUIVALENT

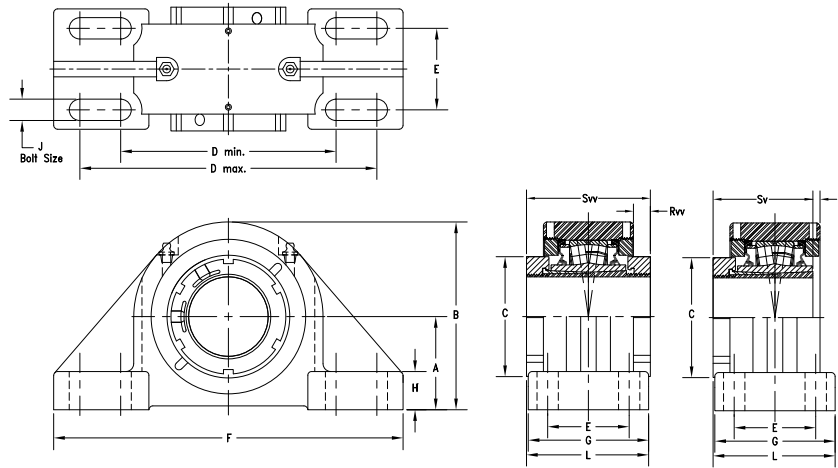

Bearing Part No. ⁽¹⁾⁽²⁾	Shaft Dia.	Bearing No.	A	B	C	D min.	D max.	E	F	G	H	J	L	Rv ⁽¹⁾	Rvv	Sv ⁽¹⁾	Svv	Wt.
	mm in.		mm in.	mm in.	mm in.	mm in.	mm in.	mm in.	mm in.	mm in.	mm in.	mm in.	mm in.	mm in.	mm in.	mm in.	mm in.	kg lbs.
QVPX22V311S QVVPX22V311S	3 1/16 in.	22222	127.0 5.00	239.8 9.44	139.7 5.50	317.5 12.50	355.6 14.00	88.9 3.50	425.5 16.75	139.7 5.50	41.4 1.63	24 7/8	135.1 5.32	8.2 0.32	15.2 0.60	104.9 4.13	130.3 5.13	30.4 67
QVPX22V312S QVVPX22V312S	3 3/8 in.																	
QVPX22V100S QVVPX22V100S	100 mm																	
QVPX22V315S QVVPX22V315S	3 15/16 in.																	
QVPX22V400S QVVPX22V400S	4 in.																	
QVPX26V110S QVVPX26V110S	110 mm																	
QVPX26V407S QVVPX26V407S	4 7/16 in.																	
QVPX26V408S QVVPX26V408S	4 1/2 in.																	
QVPX26V115S QVVPX26V115S	115 mm																	
QVPX28V125S QVVPX28V125S	125 mm	22228	155.6 6.125	293.4 11.55	190.0 7.48	387.4 15.25	425.5 16.75	108.0 4.25	514.4 20.25	171.5 6.75	50.8 2.00	24 1 1/8	175.0 6.89	0.2 0.01	30.7 1.21	147.8 5.82	178.3 7.02	61.7 136
QVPX28V415S QVVPX28V415S	4 15/16 in.																	
QVPX28V500S QVVPX28V500S	5 in.																	
QVPX28V130S QVVPX28V130S	130 mm																	

⁽¹⁾Bearing part numbers use QV to designate single-nut units (uses Rv and Sv dimensions) and QVV to designate double-nut units (uses Rvv and Svv dimensions).

⁽²⁾Single-nut (QV) part number shown. Double-nut (QVV) version available upon request.

QVPXT AND QVVPXT 5000 SERIES TWO-BOLT PILLOW BLOCKS – STRAIGHT BORE EQUIVALENT

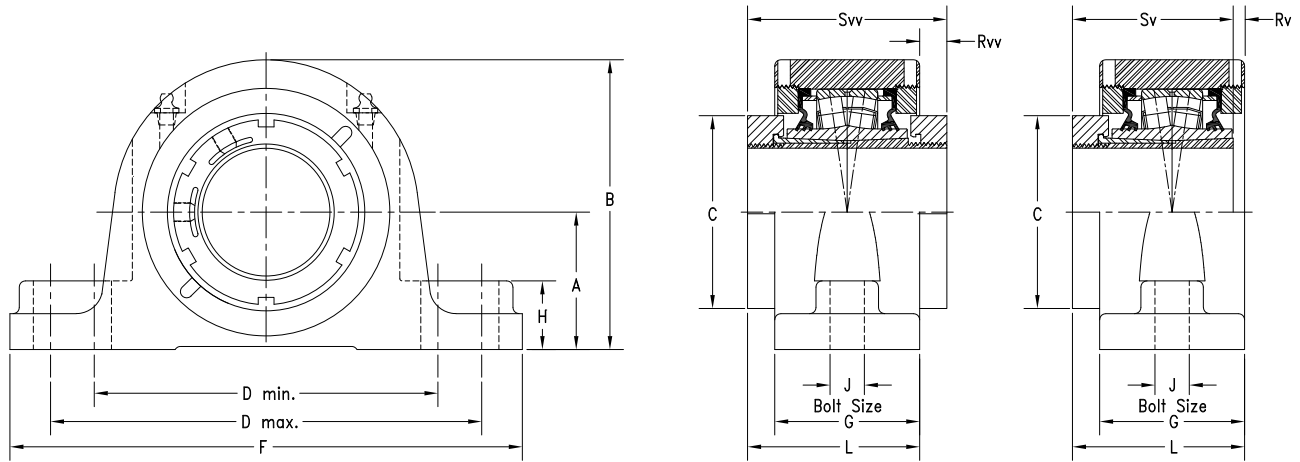

Bearing Part No. ⁽¹⁾⁽²⁾	Shaft Dia.	Bearing No.	A	B	C	D min.	D max.	F	G	H	J	L	Rv ⁽¹⁾	Rvv	Sv ⁽¹⁾	Svv	Wt.
	mm in.		mm in.	mm in.	mm in.	mm in.	mm in.	mm in.	mm in.	mm in.	mm in.	mm in.	mm in.	mm in.	mm in.	mm in.	kg lbs.
QVPXT14V060S QVVPXT14V060S	60 mm	22214	76.2 3.00	153.7 6.05	94.0 3.70	194.6 7.66	233.0 8.78	285.8 11.25	73.7 2.90	35.1 1.38	20 ¾	88.9 3.50	6.6 0.26	15.2 0.60	81.0 3.19	103.9 4.09	10.0 22
QVPXT14V207S QVVPXT14V207S	2 7/8 in.																
QVPXT14V208S QVVPXT14V208S	2 ½ in.																
QVPXT14V065S QVVPXT14V065S	65 mm																
QVPXT16V211S QVVPXT16V211S	2 11/16 in.																
QVPXT16V212S QVVPXT16V212S	2 ¾ in.	22216	88.9 3.50	173.7 6.84	106.4 4.19	230.1 9.06	265.2 10.44	330.2 13.00	75.7 2.98	35.1 1.38	24 7/8	90.9 3.58	6.0 0.24	15.2 0.60	83.6 3.29	106.2 4.18	12.7 28
QVPXT16V070S QVVPXT16V070S	70 mm																
QVPXT16V215S QVVPXT16V215S	2 15/16 in.																
QVPXT16V300S QVVPXT16V300S	3 in.																
QVPXT16V075S QVVPXT16V075S	75 mm																

⁽¹⁾Bearing part numbers use QV to designate single-nut units (uses Rv and Sv dimensions) and QVV to designate double-nut units (uses Rvv and Svv dimensions).

⁽²⁾Single-nut (QV) part number shown. Double-nut (QVV) version available upon request.

QVPG AND QVPG SN-STYLE FOUR-BOLT PILLOW BLOCKS – TAPERED BORE EQUIVALENT

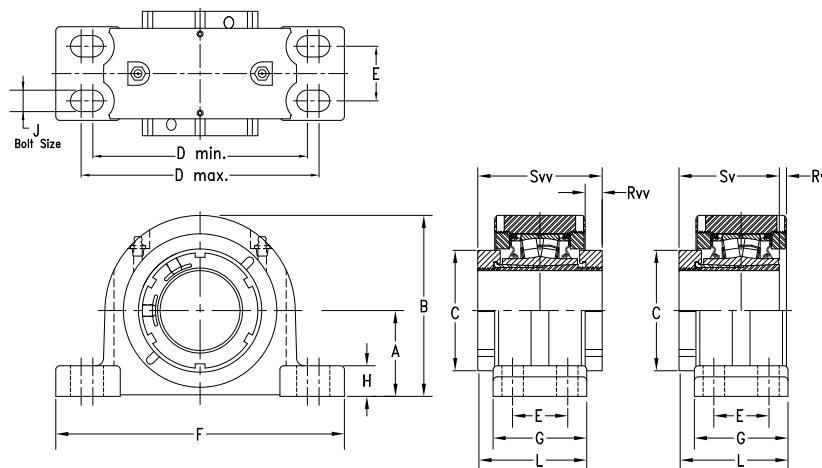

Bearing Part No. ⁽¹⁾⁽²⁾	Shaft Dia.	Bearing No.	A	B	C	D min.	D max.	E	F	G	H	J	L	Rv ⁽¹⁾	Rvv	Sv ⁽¹⁾	Svv	Wt.
	mm in.		mm in.	mm in.	mm in.	mm in.	mm in.	mm in.	mm in.	mm in.	mm in.	mm in.	mm in.	mm in.	mm in.	mm in.	mm in.	kg lbs.
QVPG11V115S QVPG11V115S	1 15/16 in.	22211	69.9 2.75	134.9 5.31	75.9 2.99	182.4 7.18	217.4 8.56	39.9 1.57	251.0 9.88	68.6 2.70	31.8 1.25	16 5/8	85.3 3.36	1.4 0.06	20.8 0.82	79.8 3.14	102.1 4.02	8.6 19
QVPG11V200S QVPG11V200S	2 in.																	
QVPG11V050S QVPG11V050S	50 mm																	
QVPG12V055S QVPG12V055S	55 mm	22212	70.0 2.756	140.5 5.53	80.0 3.16	177.8 7.00	219.2 8.63	35.1 1.38	254.0 10.00	69.9 2.75	31.8 1.25	12 1/2	86.1 3.39	1.4 0.06	20.8 0.82	79.8 3.14	102.1 4.02	9.9 22
QVPG13V203S QVPG13V203S	2 3/16 in.	22213	80.0 3.15	154.9 6.10	80.3 3.16	182.4 7.18	217.4 8.56	48.0 1.89	261.9 10.31	82.6 3.25	35.1 1.38	16 5/8	92.5 3.64	0.2 0.67	17.0 0.01	85.3 0.67	102.1 3.36	11.3 25
QVPG13V204S QVPG13V204S	2 1/4 in.																	
QVPG14V060S QVPG14V060S	60 mm	22214	80.0 3.15	154.9 6.20	94.0 3.70	182.4 7.18	217.4 8.56	48.0 1.89	261.9 10.31	82.6 3.25	35.1 1.38	16 5/8	93.2 3.67	6.6 0.26	13.7 0.54	81.0 3.19	103.9 4.09	11.3 25
QVPG15V207S QVPG15V207S	2 7/16 in.	22215	80.0 3.15	162.1 6.38	94.0 3.70	201.7 7.94	246.1 9.69	39.6 1.56	276.4 10.88	79.5 3.13	30.2 1.19	16 5/8	91.7 3.61	4.7 0.26	15.7 0.62	81.0 3.19	103.9 4.09	13.2 29
QVPG15V208S QVPG15V208S	2 1/2 in.																	
QVPG15V065S QVPG15V065S	65 mm																	
QVPG16V211S QVPG16V211S	2 11/16 in.	22216	95.0 3.74	180.3 7.10	105.9 4.17	235.0 9.25	266.7 10.50	50.0 1.97	315.0 12.4	89.9 3.54	31.8 1.25	16 5/8	98.0 3.86	4.5 0.18	16.8 0.66	83.6 3.29	105.9 4.17	14.9 33
QVPG16V212S QVPG16V212S	2 3/4 in.																	
QVPG16V070S QVPG16V070S	70 mm																	
QVPG17V215S QVPG17V215S	2 15/16 in.	22217	95.0 3.74	182.9 7.20	106.4 4.19	240.0 9.44	287.3 11.31	52.3 2.06	320.8 12.63	92.2 3.63	31.8 1.25	20 3/4	99.3 3.91	6.6 0.26	15.0 0.59	84.6 3.33	106.2 4.18	16.8 37
QVPG17V300S QVPG17V300S	3 in.																	
QVPG17V075S QVPG17V075S	75 mm																	
QVPG19V303S QVPG19V303S	3 3/16 in.	22219	100.0 3.937	195.3 7.69	124.0 4.88	282.7 11.13	298.5 11.75	50.0 1.97	344.9 13.58	100.1 3.94	39.6 1.56	16 5/8	109.2 4.30	7.2 0.29	19.3 0.76	93.7 3.69	118.1 4.65	24.5 54
QVPG19V304S QVPG19V304S	3 1/4 in.																	
QVPG19V080S QVPG19V080S	80 mm																	

⁽¹⁾Bearing part numbers use QV to designate single-nut units (uses Rv and Sv dimensions) and QVV to designate double-nut units (uses Rvv and Svv dimensions).

Continued on next page.

⁽²⁾Single-nut (QV) part number shown. Double-nut (QVV) version available upon request.

QVPG AND QVPG SN-STYLE FOUR-BOLT PILLOW BLOCKS – TAPERED BORE EQUIVALENT – continued

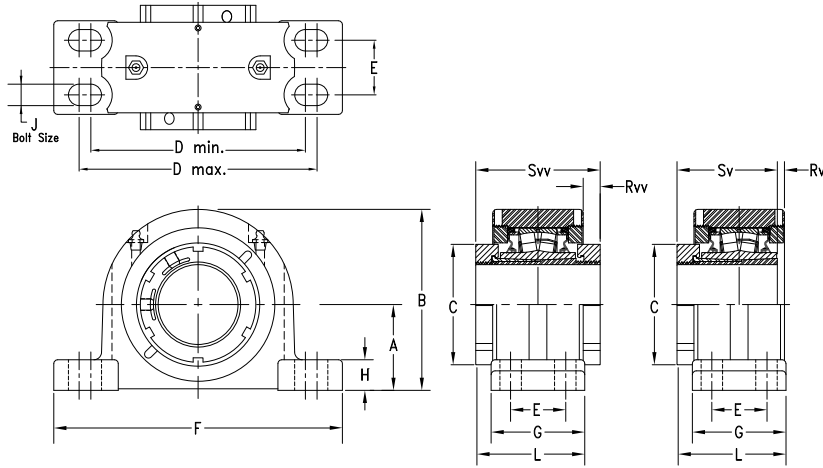

Bearing Part No. ⁽¹⁾⁽²⁾	Shaft Dia.	Bearing No.	A	B	C	D min.	D max.	E	F	G	H	J	L	Rv ⁽¹⁾	Rvv	Sv ⁽¹⁾	Svv	Wt.
	mm in.		mm in.	mm in.	mm in.	mm in.	mm in.	mm in.	mm in.	mm in.	mm in.	mm in.	mm in.	mm in.	mm in.	mm in.	mm in.	kg lbs.
QVPG19V085S QVVPG19V085S	85 mm	22219	112.0 4.409	212.3 8.36	124.0 4.88	282.7 11.13	298.5 11.75	50.0 1.97	344.9 13.58	100.1 3.94	39.6 1.56	16 5/8	109.2 4.30	4.7 0.19	17.8 0.70	93.7 3.69	118.1 4.65	25.4 56
QVPG20V307S QVVPG20V307S	3 7/8 in.	22220	112.0 4.409	214.6 8.45	124.5 4.90	276.4 10.88	339.9 13.38	60.5 2.38	381.0 15.00	109.5 4.31	39.6 1.56	20 3/4	113.5 4.47	11.0 0.43	11.2 0.44	95.3 3.75	117.6 4.63	31.8 70
QVPG20V308S QVVPG20V308S	3 1/2 in.																	
QVPG20V090S QVVPG20V090S	90 mm																	
QVVPG22V311S	3 1/8 in.																	
QVVPG22V312S	3 3/4 in.	22222	125.0 4.921	238.3 9.38	139.7 5.50	301.8 11.88	368.3 14.50	69.9 2.75	409.7 16.13	120.7 4.75	44.5 1.75	20 3/4	125.5 4.94	9.3 0.36	14.5 0.57	104.9 4.13	130.3 5.13	39.5 87
QVVPG22V100S	100 mm																	
QVVPG22V315S	3 5/8 in.																	
QVVPG22V400S	4 in.																	
QVVPG24V110S	110 mm	22224	140.0 5.512	262.9 10.35	174.8 6.88	330.2 13.00	355.6 14.00	70.1 2.76	410.0 16.14	120.7 4.75	50.8 2.00	16 5/8	149.6 5.89	7.9 0.31	40.4 1.59	147.8 5.82	178.3 7.02	49.9 110
QVVPG26V407S	4 7/8 in.	22226	150.0 5.906	281.7 11.09	174.8 6.88	367.3 14.46	400.1 15.75	81.0 3.19	444.5 17.50	128.0 5.04	49.3 1.94	24 1	153.2 6.03	6.0 0.24	36.6 1.44	147.8 5.82	178.3 7.02	61.7 136
QVVPG26V408S	4 1/2 in.																	
QVVPG26V115S	115 mm																	
QVVPG28V125S	125 mm	22228	150.0 5.906	288.5 11.36	190.0 7.48	384.3 15.13	447.8 17.63	80.0 3.15	500.4 19.70	128.0 5.04	49.3 1.94	24 1	152.9 6.02	1.0 0.04	31.8 1.25	147.8 5.82	178.3 7.02	61.7 136
QVVPG28V415S	4 1/8 in.																	
QVVPG28V500S	5 in.																	
QVVPG28V130S	130 mm																	

⁽¹⁾Bearing part numbers use QV to designate single-nut units (uses Rv and Sv dimensions) and QVV to designate double-nut units (uses Rvv and Svv dimensions).

⁽²⁾Single-nut (QV) part number shown. Double-nut (QVV) version available upon request.

QVPH AND QVVPH SAF-STYLE FOUR-BOLT PILLOW BLOCKS – TAPERED BORE EQUIVALENT

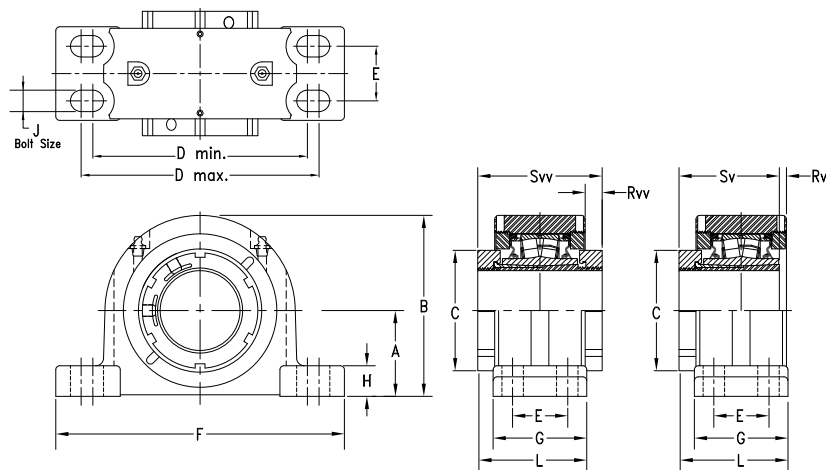

Bearing Part No. ⁽¹⁾⁽²⁾	Shaft Dia.	Bearing No.	A	B	C	D min.	D max.	E	F	G	H	J	L	Rv ⁽¹⁾	Rvv	Sv ⁽¹⁾	Svv	Wt.	
	mm in.		mm in.	mm in.	mm in.	mm in.	mm in.	mm in.	mm in.	mm in.	mm in.	mm in.	mm in.	mm in.	mm in.	mm in.	mm in.	kg lbs.	
QVPH11V115S QVVPH11V115S	1 1/8 in.	22211	69.9	134.9	75.9	182.4	217.4	39.9	251.0	68.6	31.8	16	85.3	1.4	20.8	79.8	102.1	8.6	
QVPH11V200S QVVPH11V200S	2 in.		2.75	5.31	2.99	7.18	8.56	1.57	9.88	2.70	1.25	5/8	3.36	0.06	0.82	3.14	4.02	19	
QVPH11V050S QVVPH11V050S	50 mm																		
QVPH13V203S QVVPH13V203S	2 3/8 in.		22213	76.2	151.1	80.3	182.4	217.4	50.8	261.9	82.6	31.2	12	92.5	0.2	17.0	85.3	102.1	11.3
QVPH13V204S QVVPH13V204S	2 1/4 in.	3.00		5.95	3.16	7.18	8.56	2.00	10.31	3.25	1.23	1/2	3.64	0.01	0.67	3.36	4.02	25	
QVPH13V055S QVVPH13V055S	55 mm																		
QVPH15V060S QVVPH15V060S	60 mm																		
QVPH15V207S QVVPH15V207S	2 7/8 in.	22215	82.6	162.1	94.0	201.7	246.1	47.8	276.4	79.5	32.8	12	91.7	4.7	18.0	82.6	103.9	13.2	
QVPH15V208S QVVPH15V208S	2 1/2 in.		3.25	6.38	3.70	7.94	9.69	1.88	10.88	3.13	1.29	1/2	3.61	0.19	0.71	3.25	4.09	29	
QVPH15V065S QVVPH15V065S	65 mm																		
QVPH16V211S QVVPH16V211S	2 1/4 in.		22216	88.9	176.7	109.2	228.6	279.4	54.0	300.2	72.6	31.8	16	96.3	4.5	15.5	83.6	103.9	14.9
QVPH16V212S QVVPH16V212S	2 3/4 in.	3.50		6.96	4.30	9.00	11.00	2.13	13.00	2.86	1.25	5/8	3.79	0.18	0.61	3.29	4.09	33	
QVPH16V070S QVVPH16V070S	70 mm																		
QVPH17V215S QVVPH17V215S	2 15/16 in.	22217		95.3	182.9	106.4	240.0	287.3	54.1	320.8	92.2	32.0	16	99.3	6.6	15.0	84.6	106.2	16.8
QVPH17V300S QVVPH17V300S	3 in.		3.75	7.20	4.19	9.44	11.31	2.13	12.63	3.63	1.26	5/8	3.91	0.26	0.59	3.33	4.18	37	
QVPH17V075S QVVPH17V075S	75 mm																		
QVPH19V303S QVVPH19V303S	3 3/8 in.		22219	101.6	202.2	124.5	254.0	298.5	54.0	349.3	98.4	41.3	16	106.3	3.2	17.2	93.7	114.1	24.5
QVPH19V304S QVVPH19V304S	3 1/4 in.	4.00		7.96	4.90	10.00	11.75	2.13	13.75	3.88	1.63	5/8	4.18	0.13	0.68	3.69	4.49	54	
QVPH19V080S QVVPH19V080S	80 mm																		

⁽¹⁾Bearing part numbers use QV to designate single-nut units (uses Rv and Sv dimensions) and QVV to designate double-nut units (uses Rvv and Svv dimensions).

⁽²⁾Single-nut (QV) part number shown. Double-nut (QVV) version available upon request.

Continued on next page.

QVPH AND QVVPH SAF-STYLE FOUR-BOLT PILLOW BLOCKS – TAPERED BORE EQUIVALENT – continued

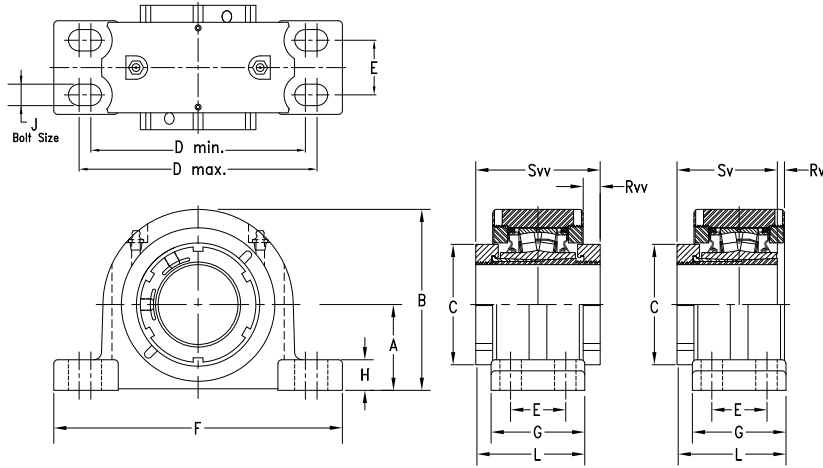

Bearing Part No. ⁽¹⁾⁽²⁾	Shaft Dia.	Bearing No.	A	B	C	D min.	D max.	E	F	G	H	J	L	Rv ⁽¹⁾	Rvv	Sv ⁽¹⁾	Svv	Wt.
	mm in.		mm in.	mm in.	mm in.	mm in.	mm in.	mm in.	mm in.	mm in.	mm in.	mm in.	mm in.	mm in.	mm in.	mm in.	mm in.	kg lbs.
QVPH20V303S QVVPH20V303S	3 3/16 in.	22220	114.3	216.9	124.5	276.4	339.9	60.5	381.0	109.5	41.9	20	113.5	11.0	11.2	95.3	117.6	31.8
QVPH20V304S QVVPH20V304S	3 1/4 in.																	
QVPH20V080S QVVPH20V080S	80 mm																	
QVPH20V085S QVVPH20V085S	85 mm																	
QVPH20V307S QVVPH20V307S	3 7/16 in.																	
QVPH20V308S QVVPH20V308S	3 1/2 in.																	
QVPH20V090S QVVPH20V090S	90 mm	22222	125.5	238.3	139.7	301.8	368.3	69.9	406.4	120.7	45.0	20	125.5	9.3	14.5	104.9	130.3	39.5
QVPH22V311S QVVPH22V311S	3 1/16 in.																	
QVPH22V312S QVVPH22V312S	3 3/4 in.																	
QVPH22V100S QVVPH22V100S	100 mm																	
QVPH22V315S QVVPH22V315S	3 15/16 in.																	
QVPH22V400S QVVPH22V400S	4 in.																	
QVPH24V110S QVVPH24V110S	110 mm	22224	133.4 5.25	256.8 10.11	174.6 6.87	301.8 11.88	368.3 14.50	69.9 2.75	419.1 16.50	120.7 4.75	50.8 2.00	20 3/4	149.5 5.89	9.8 0.38	40.3 1.59	147.8 5.82	178.3 7.02	49.9 110
QVPH26V407S QVVPH26V407S	4 7/16 in.	22226	152.4	284.0	174.8	362.0	400.1	82.6	444.5	128.0	51.8	22	153.2	6.6	36.6	147.8	178.3	61.7
QVPH26V408S QVVPH26V408S	4 1/2 in.																	
QVPH26V115S QVVPH26V115S	115 mm																	
QVPH28V125S QVVPH28V125S	125 mm	22228	152.4 6.00	290.8 11.45	190.0 7.48	406.4 16.00	435.1 17.13	85.9 3.38	500.4 19.70	128.0 5.04	51.8 2.04	24 1	152.9 6.02	1.0 0.04	31.8 1.25	147.8 5.82	178.3 7.02	61.7 136
QVPH28V415S QVVPH28V415S	4 15/16 in.																	
QVPH28V500S QVVPH28V500S	5 in.																	
QVPH28V130S QVVPH28V130S	130 mm																	

⁽¹⁾Bearing part numbers use QV to designate single-nut units (uses Rv and Sv dimensions) and QVV to designate double-nut units (uses Rvv and Svv dimensions).
⁽²⁾Single-nut (QV) part number shown. Double-nut (QVV) version available upon request.

QVPK AND QVVPK 9000 SERIES FOUR-BOLT PILLOW BLOCKS – TAPERED BORE EQUIVALENT

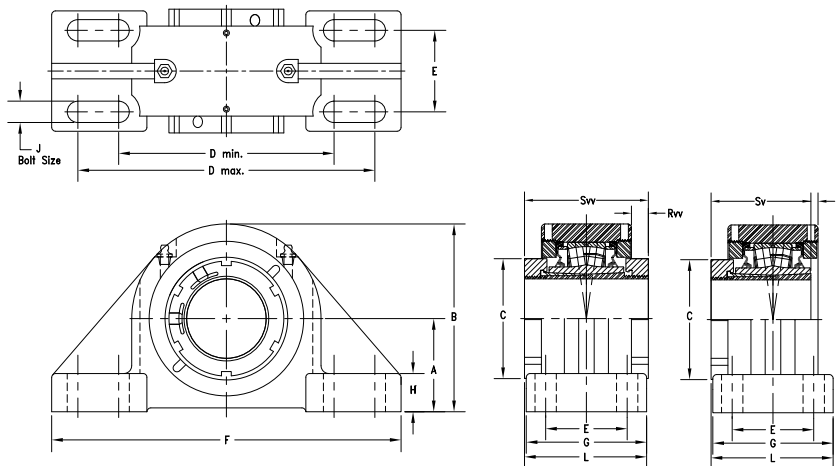

Bearing Part No. ⁽¹⁾⁽²⁾	Shaft Dia.	Bearing No.	A	B	C	D min.	D max.	E	F	G	H	J	L	Rv ⁽¹⁾	Rvv	Sv ⁽¹⁾	Svv	Wt.
	mm in.		mm in.	mm in.	mm in.	mm in.	mm in.	mm in.	mm in.	mm in.	mm in.	mm in.	mm in.	mm in.	mm in.	mm in.	mm in.	kg lbs.
QVPK15V060S QVVPK15V060S	60 mm	22215	88.9 3.50	176.0 6.83	94.0 3.70	230.1 9.06	265.2 10.44	69.9 2.75	330.2 13.00	108.0 4.25	39.1 1.54	20 ¾	105.9 4.17	8.3 0.33	12.6 0.51	82.6 3.25	103.9 4.09	13.2 29
QVPK15V207S QVVPK15V207S	2 7/16 in.																	
QVPK15V208S QVVPK15V208S	2 1/2 in.																	
QVPK15V065S QVVPK15V065S	65 mm																	
QVPK17V211S QVVPK17V211S	2 11/16 in.	22217	101.6 4.00	201.2 7.92	106.4 4.19	274.6 10.81	309.6 12.19	76.2 3.00	381.0 15.00	120.7 4.75	38.1 1.50	20 ¾	113.5 4.47	13.0 0.51	8.64 0.34	84.6 3.33	106.2 4.18	16.8 37
QVPK17V212S QVVPK17V212S	2 3/4 in.																	
QVPK17V070S QVVPK17V070S	70 mm																	
QVPK17V215S QVVPK17V215S	2 15/16 in.																	
QVPK17V300S QVVPK17V300S	3 in.	22220	127.0 5.00	240.0 9.44	124.5 4.90	317.5 12.50	355.6 14.00	88.9 3.50	425.5 16.75	139.7 5.50	41.4 1.63	24 7/8	128.8 5.07	13.1 0.52	8.9 0.35	95.3 3.75	117.6 4.63	31.8 70
QVPK20V303S QVVPK20V303S	3 3/16 in.																	
QVPK20V304S QVVPK20V304S	3 3/4 in.																	
QVPK20V080S QVVPK20V080S	80 mm																	
QVPK20V085S QVVPK20V085S	85 mm																	
QVPK20V307S QVVPK20V307S	3 7/16 in.																	
QVPK20V308S QVVPK20V308S	3 1/2 in.																	
QVPK20V090S QVVPK20V090S	90 mm																	

⁽¹⁾ Bearing part numbers use QV to designate single-nut units (uses Rv and Sv dimensions) and QVV to designate double-nut units (uses Rvv and Svv dimensions).

⁽²⁾ Single-nut (QV) part number shown. Double-nut (QVV) version available upon request.

Continued on next page.

QVPK AND QVVPK 9000 SERIES FOUR-BOLT PILLOW BLOCKS – TAPERED BORE EQUIVALENT – continued

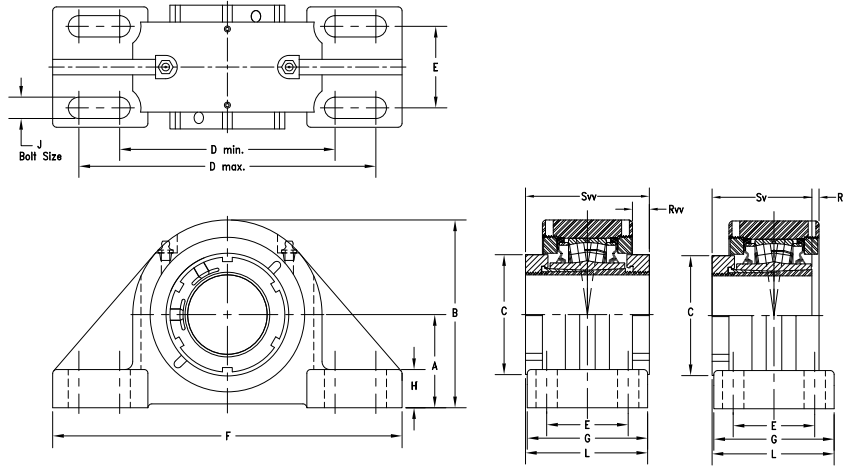

Bearing Part No. ⁽¹⁾⁽²⁾	Shaft Dia.	Bearing No.	A	B	C	D min.	D max.	E	F	G	H	J	L	Rv ⁽¹⁾	Rvv	Sv ⁽¹⁾	Svv	Wt.
	mm in.		mm in.	mm in.	mm in.	mm in.	mm in.	mm in.	mm in.	mm in.	mm in.	mm in.	mm in.	mm in.	mm in.	mm in.	mm in.	kg lbs.
QVPK22V311S QVVPK22V311S	3 1/16 in.	22222	146.1 5.75	273.8 10.78	139.7 5.50	354.1 13.94	395.2 15.56	101.6 4.00	469.9 18.50	158.8 6.25	45.7 1.80	24 1	138.4 5.45	9.3 0.36	14.5 0.57	104.9 4.13	130.3 5.13	39.5 87
QVPK22V312S QVVPK22V312S	3 3/4 in.																	
QVPK22V100S QVVPK22V100S	100 mm																	
QVPK22V315S QVVPK22V315S	3 15/16 in.																	
QVPK22V400S QVVPK22V400S	4 in.																	
QVPK26V110S QVVPK26V110S	110 mm	22226	155.7 6.13	283.2 11.15	174.8 6.88	387.4 15.25	425.5 16.75	108.0 4.25	514.4 20.25	171.5 6.75	50.8 2.00	24 1	175.3 6.90	1.5 0.06	31.5 1.24	147.8 5.82	178.3 7.02	61.7 136
QVPK26V407S QVVPK26V407S	4 7/16 in.																	
QVPK26V408S QVVPK26V408S	4 1/2 in.																	
QVPK26V115S QVVPK26V115S	115 mm																	

⁽¹⁾Bearing part numbers use QV to designate single-nut units (uses Rv and Sv dimensions) and QVV to designate double-nut units (uses Rvv and Svv dimensions).

⁽²⁾Single-nut (QV) part number shown. Double-nut (QVV) version available upon request.

QVF AND QVVF SQUARE FLANGE BLOCKS – STRAIGHT BORE EQUIVALENT

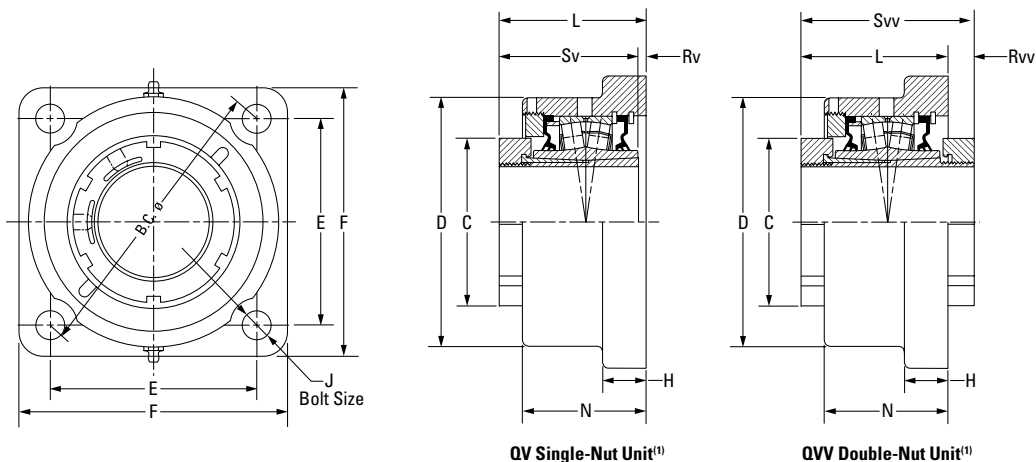

Bearing Part No. ⁽¹⁾⁽²⁾	Shaft Dia.	Bearing No.	C	D	E	B.C.	F	H	J	L FIX	L EXP	N	Rv ⁽¹⁾	Rvv	Sv ⁽¹⁾	Svv	Wt.
	mm in.		mm in.	mm in.	mm in.	mm in.	mm in.	mm in.	mm in.	mm in.	mm in.	mm in.	mm in.	mm in.	mm in.	mm in.	kg lbs.
QVF11V115S QVVF11V115S	1 15/16 in.	22211	75.9	120.7	111.3	157.0	139.7	22.4	12	84.1	86.1	65.0	4.1	18.3	79.8	102.1	5.0
QVF11V200S QVVF11V200S	2 in.		2.99	4.75	4.38	6.18	5.50	0.88	1/2	3.31	3.39	2.56	0.16	0.72	3.14	4.02	11
QVF11V050S QVVF11V050S	50 mm	22212	80.3	130.3	124.0	175.0	157.2	25.4	16	84.3	86.4	66.8	4.6	17.8	79.8	102.1	6.4
QVF12V203S QVVF12V203S	2 3/8 in.		3.16	5.13	4.88	6.89	6.19	1.00	5/8	3.32	3.40	2.63	0.18	0.70	3.14	4.02	14
QVF12V204S QVVF12V204S	2 1/4 in.	22214	94.0	146.1	136.7	193.0	168.4	25.4	16	85.1	87.1	72.4	4.1	16.0	81.0	101.3	7.7
QVF12V055S QVVF12V055S	55 mm		3.70	5.75	5.38	7.60	6.63	1.00	5/8	3.35	3.43	2.85	0.16	0.63	3.19	3.99	17
QVF14V060S QVVF14V060S	60 mm	22216	106.4	168.9	152.4	215.4	189.0	26.9	20	87.6	89.7	75.7	4.1	16.3	83.6	103.6	10.4
QVF14V207S QVVF14V207S	2 7/16 in.		4.19	6.65	6.00	8.48	7.44	1.06	3/4	3.45	3.53	2.98	0.16	0.64	3.29	4.08	23
QVF14V208S QVVF14V208S	2 1/2 in.																
QVF14V065S QVVF14V065S	65 mm																
QVF16V211S QVVF16V211S	2 11/16 in.																
QVF16V212S QVVF16V212S	2 3/4 in.																
QVF16V070S QVVF16V070S	70 mm																
QVF16V215S QVVF16V215S	2 15/16 in.																
QVF16V300S QVVF16V300S	3 in.																
QVF16V075S QVVF16V075S	75 mm																

⁽¹⁾Bearing part numbers use QV to designate single-nut units (uses Rv and Sv dimensions) and QVV to designate double-nut units (uses Rvv and Svv dimensions).

Continued on next page.

⁽²⁾Single-nut (QV) part number shown. Double-nut (QVV) version available upon request.

QVF AND QVVF SQUARE FLANGE BLOCKS – STRAIGHT BORE EQUIVALENT – *continued*

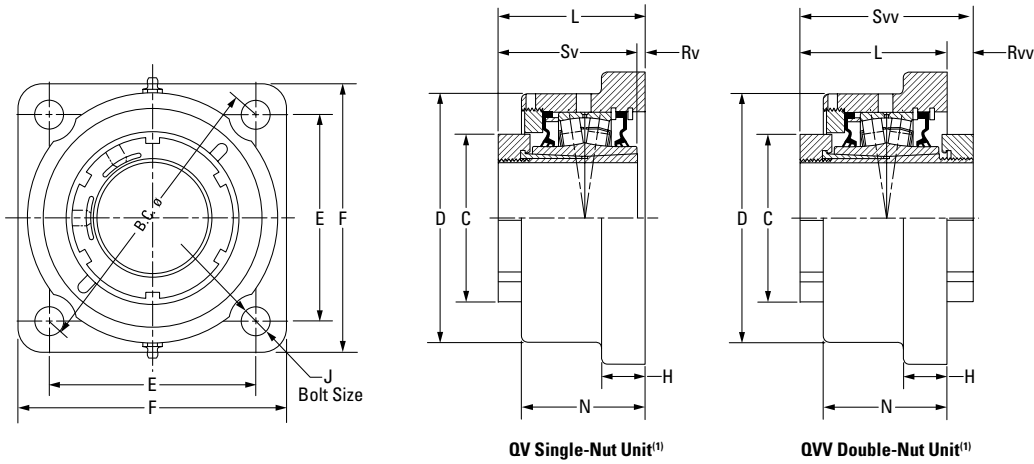

Bearing Part No. ⁽¹⁾⁽²⁾	Shaft Dia.	Bearing No.	C	D	E	B.C.	F	H	J	L FIX	L EXP	N	Rv ⁽¹⁾	Rvv	Sv ⁽¹⁾	Svv	Wt.
	mm in.		mm in.	mm in.	mm in.	mm in.	mm in.	mm in.	mm in.	mm in.	mm in.	mm in.	mm in.	mm in.	mm in.	mm in.	kg lbs.
QVF19V303S QVVF19V303S	3 3/16 in.	22219	124.5 4.90	193.8 7.63	177.8 7.00	251.7 9.91	219.2 8.63	33.3 1.31	20 3/4	98.3 3.87	100.3 3.95	84.1 3.31	4.6 0.18	15.7 0.62	93.7 3.69	114.0 4.49	15.9 35
QVF19V304S QVVF19V304S	3 1/4 in.																
QVF19V080S QVVF19V080S	80 mm																
QVF19V085S QVVF19V085S	85 mm																
QVF19V307S QVVF19V307S	3 7/16 in.																
QVF19V308S QVVF19V308S	3 1/2 in.																
QVF19V090S QVVF19V090S	90 mm																
QVF22V311S QVVF22V311S	3 1/16 in.																
QVF22V312S QVVF22V312S	3 3/4 in.																
QVF22V100S QVVF22V100S	100 mm																
QVF22V315S QVVF22V315S	3 15/16 in.																
QVF22V400S QVVF22V400S	4 in.																
QVF26V110S QVVF26V110S	110 mm	22226	174.8 6.88	256.8 10.11	222.3 8.75	314.5 12.38	276.4 10.88	38.1 1.50	24 7/8	140.5 5.53	142.7 5.62	106.9 4.21	7.4 0.29	37.8 1.49	147.8 5.82	178.3 7.02	28.6 63
QVF26V407S QVVF26V407S	4 7/16 in.																
QVF26V408S QVVF26V408S	4 1/2 in.																
QVF26V115S QVVF26V115S	115 mm																

⁽¹⁾Bearing part numbers use QV to designate single-nut units (uses Rv and Sv dimensions) and QVV to designate double-nut units (uses Rvv and Svv dimensions).
⁽²⁾Single-nut (QV) part number shown. Double-nut (QVV) version available upon request.

QVFB AND QVFB SQUARE FLANGE BLOCKS – TAPERED ADAPTER EQUIVALENT

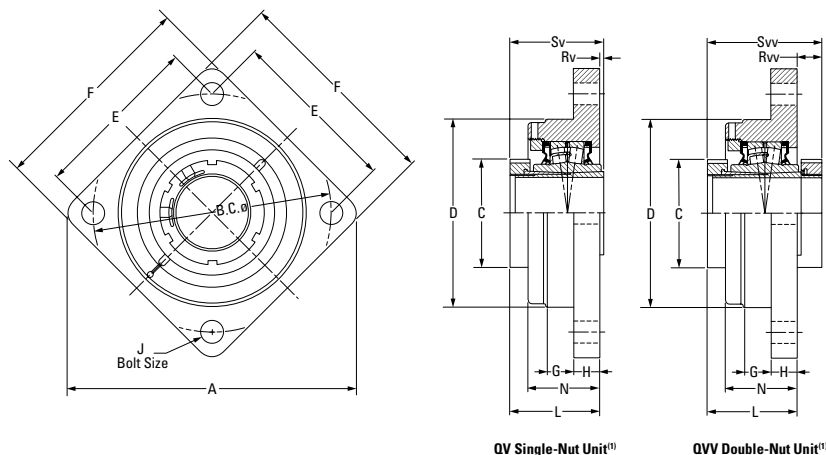

Bearing Part No. ⁽¹⁾⁽²⁾	Shaft Dia.	Bearing No.	A	B.C.	C	D	E	F	G	H	J	L	N	Rv ⁽¹⁾	Rvv	Sv ⁽¹⁾	Svv	Wt.
	mm in.		mm in.	mm in.	mm in.	mm in.	mm in.	mm in.	mm in.	mm in.	mm in.	mm in.	mm in.	mm in.	mm in.	mm in.	mm in.	kg lbs.
QVFB15V060S QVFB15V060S	60 mm	22215	255.0 10.04	215.1 8.47	94.0 3.70	169.9 6.69	152.4 6.00	192.0 7.56	25.4 1.00	23.9 0.94	16 %	81.5 3.21	64.8 2.55	0.8 0.03	22.4 0.88	82.6 3.25	103.9 4.09	11.3 25
QVFB15V207S QVFB15V207S	2 7/16 in.																	
QVFB15V208S QVFB15V208S	2 1/2 in.																	
QVFB15V065S QVFB15V065S	65 mm																	
QVFB17V211S QVFB17V211S	2 11/16 in.	22217	282.4 11.12	240.0 9.45	106.4 4.19	190.0 7.48	169.7 6.68	212.1 8.35	25.4 1.00	25.4 1.00	16 %	83.8 3.30	69.9 2.75	1.0 0.04	22.4 0.88	84.6 3.33	106.2 4.18	13.6 30
QVFB17V212S QVFB17V212S	2 3/4 in.																	
QVFB17V070S QVFB17V070S	70 mm																	
QVFB17V215S QVFB17V215S	2 15/16 in.																	
QVFB17V300S QVFB17V300S	3 in.	22220	330.2 13.00	279.9 11.02	124.5 4.90	230.1 9.06	197.9 7.79	247.9 9.76	31.8 1.25	28.7 1.13	20 %	106.7 4.20	94.2 3.71	11.4 0.45	10.9 0.43	95.3 3.75	117.3 4.62	18.1 40
QVFB20V303S QVFB20V303S	3 3/8 in.																	
QVFB20V304S QVFB20V304S	3 1/4 in.																	
QVFB20V080S QVFB20V080S	80 mm																	
QVFB20V085S QVFB20V085S	85 mm																	
QVFB20V307S QVFB20V307S	3 7/16 in.																	
QVFB20V308S QVFB20V308S	3 1/2 in.																	
QVFB20V090S QVFB20V090S	90 mm																	

⁽¹⁾Bearing part numbers use QV to designate single-nut units (uses Rv and Sv dimensions) and QVV to designate double-nut units (uses Rvv and Svv dimensions).

⁽²⁾Single-nut (QV) part number shown. Double-nut (QVV) version available upon request.

Continued on next page.

QVFB AND QVFB SQUARE FLANGE BLOCKS – TAPERED ADAPTER EQUIVALENT

– continued

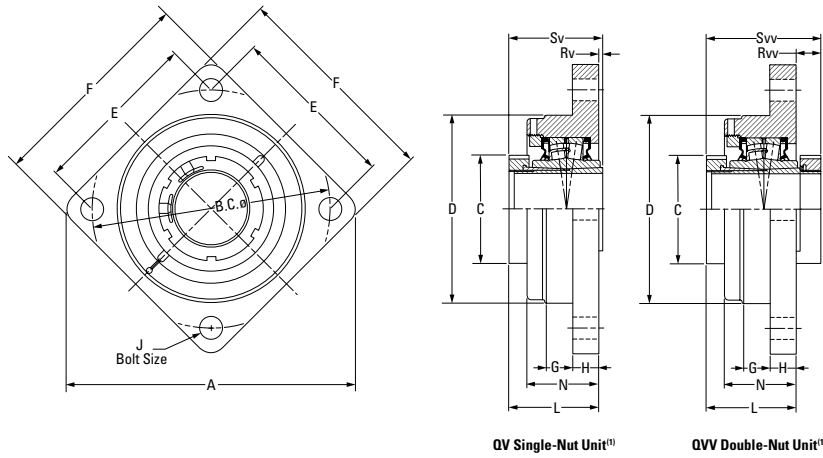

Bearing Part No. ⁽¹⁾⁽²⁾	Shaft Dia.	Bearing No.	A	B.C.	C	D	E	F	G	H	J	L	N	Rv ⁽¹⁾	Rvv	Sv ⁽¹⁾	Svv	Wt.
			mm in.	mm in.	mm in.	mm in.	mm in.	mm in.	mm in.	mm in.	mm in.	mm in.	mm in.	mm in.	mm in.	mm in.	mm in.	mm in.
QVFB22V311S QVFB22V311S	3 1/4 in.	22222	367.0 14.45	309.9 12.20	139.7 5.50	255.0 10.04	219.2 8.63	274.3 10.80	44.5 1.75	26.4 1.04	20 3/4	112.0 4.41	101.1 3.98	7.4 0.29	14.7 0.58	104.9 4.13	126.7 4.99	27.2
QVFB22V312S QVFB22V312S	3 3/4 in.																	
QVFB22V100S QVFB22V100S	100 mm																	
QVFB22V315S QVFB22V315S	3 1/2 in.																	
QVFB22V400S QVFB22V400S	4 in.																	
QVFB26V110S QVFB26V110S	110 mm																	
QVFB26V407S QVFB26V407S	4 7/8 in.																	
QVFB26V408S QVFB26V408S	4 1/2 in.																	
QVFB26V115S QVFB26V115S	115 mm																	

⁽¹⁾Bearing part numbers use QV to designate single-nut units (uses Rv and Sv dimensions) and QVV to designate double-nut units (uses Rvv and Sv dimensions).

⁽²⁾Single-nut (QV) part number shown. Double-nut (QVV) version available upon request.

QVFC AND QVVFC PILOTED FLANGE CARTRIDGES – TAPERED ADAPTER EQUIVALENT

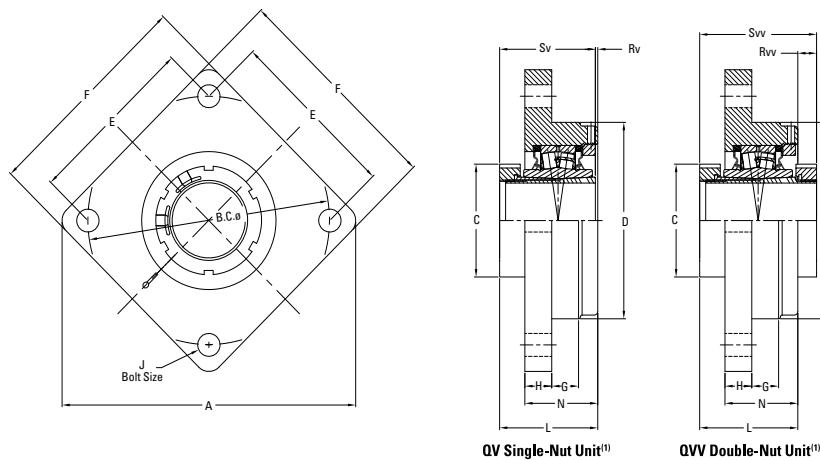

Bearing Part No. ⁽¹⁾⁽²⁾	Shaft Dia.	Bearing No.	A	B.C.	C	D ⁽³⁾	E	F	G	H	J	L	N	Rv ⁽¹⁾	Rvw	Sv ⁽¹⁾	Svw	Wt.
	mm in.		mm in.	mm in.	mm in.	mm in.	mm in.	mm in.	mm in.	mm in.	mm in.	mm in.	mm in.	mm in.	mm in.	mm in.	mm in.	kg lbs.
QVFC15V060S QVVFC15V060S	60 mm	22215	255.0 10.04	215.1 8.47	94.0 3.70	169.9 6.690	152.4 6.00	192.0 7.56	25.4 1.00	23.9 0.94	16 %	87.1 3.43	64.8 2.55	4.6 0.18	16.8 0.66	82.6 3.25	103.9 4.09	11.3 25
QVFC15V207S QVVFC15V207S	2 7/16 in.																	
QVFC15V208S QVVFC15V208S	2 1/2 in.																	
QVFC15V065S QVVFC15V065S	65 mm																	
QVFC17V211S QVVFC17V211S	2 11/16 in.	22217	282.4 11.12	240.0 9.45	106.4 4.19	190.0 7.480	169.7 6.68	212.1 8.35	25.4 1.00	25.4 1.00	16 %	91.7 3.61	69.9 2.75	6.6 0.26	14.5 0.57	84.6 3.33	106.2 4.18	13.6 30
QVFC17V212S QVVFC17V212S	2 3/4 in.																	
QVFC17V070S QVVFC17V070S	70 mm																	
QVFC17V215S QVVFC17V215S	2 15/16 in.																	
QVFC17V300S QVVFC17V300S	3 in.	22220	330.2 13.00	279.9 11.02	124.5 4.90	230.1 9.060	197.9 7.79	247.9 9.76	31.8 1.25	28.7 1.13	20 %	105.2 4.14	94.2 3.71	9.7 0.38	12.4 0.49	95.3 3.75	117.3 4.62	18.1 40
QVFC20V303S QVVFC20V303S	3 3/16 in.																	
QVFC20V304S QVVFC20V304S	3 1/4 in.																	
QVFC20V080S QVVFC20V080S	80 mm																	
QVFC20V085S QVVFC20V085S	85 mm																	
QVFC20V307S QVVFC20V307S	3 7/16 in.																	
QVFC20V308S QVVFC20V308S	3 1/2 in.																	
QVFC20V090S QVVFC20V090S	90 mm																	

⁽¹⁾Bearing part numbers use QV to designate single-nut units (uses Rv and Sv dimensions) and QVV to designate double-nut units (uses Rvw and Svw dimensions).

⁽²⁾Single-nut (QV) part number shown. Double-nut (QVV) version available upon request.

Continued on next page.

QVFC AND QVFC PILOTED FLANGE CARTRIDGES – TAPERED ADAPTER EQUIVALENT – continued

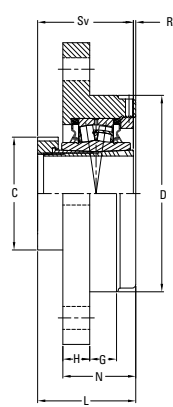
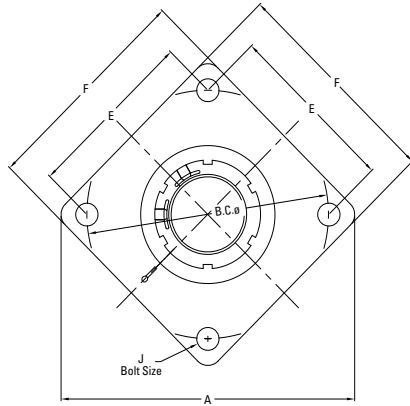

QV Single-Nut Unit⁽¹⁾

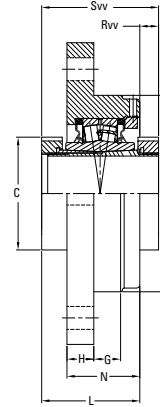

QVV Double-Nut Unit⁽¹⁾

Bearing Part No. ⁽¹⁾⁽²⁾	Shaft Dia.	Bearing No.	A	B.C.	C	D ⁽³⁾	E	F	G	H	J	L	N	Rv ⁽¹⁾	Rvv	Sv ⁽¹⁾	Svv	Wt.
	mm in.		mm in.	mm in.	mm in.	mm in.	mm in.	mm in.	mm in.	mm in.	mm in.	mm in.	mm in.	mm in.	mm in.	mm in.	mm in.	kg lbs.
QVFC22V311S QVFC22V311S	3 1/16 in.	22222	367.0 14.45	309.9 12.20	139.7 5.50	255.0 10.040	219.2 8.63	274.3 10.80	44.5 1.75	26.4 1.04	20 3/4	112.8 4.44	101.1 3.98	8.1 0.32	5.8 0.23	104.9 4.13	126.7 4.99	27.2 60
QVFC22V312S QVFC22V312S	3 3/8 in.																	
QVFC22V100S QVFC22V100S	100 mm																	
QVFC22V315S QVFC22V315S	3 15/16 in.																	
QVFC22V400S QVFC22V400S	4 in.																	
QVFC26V110S QVFC26V110S	110 mm	22226	416.1 16.38	355.1 13.98	174.8 6.88	290.0 11.417	251.0 9.88	298.5 11.75	41.9 1.65	32.0 1.26	24 7/8	144.3 5.68	114.3 4.50	3.6 0.14	34.0 1.34	147.8 5.82	178.3 7.02	42.6 94
QVFC26V407S QVFC26V407S	4 7/16 in.																	
QVFC26V408S QVFC26V408S	4 1/2 in.																	
QVFC26V115S QVFC26V115S	115 mm																	

⁽¹⁾Bearing part numbers use QV to designate single-nut units (uses Rv and Sv dimensions) and QVV to designate double-nut units (uses Rvv and Svv dimensions).

⁽²⁾Single-nut (QV) part number shown. Double-nut (QVV) version available upon request.

⁽³⁾Pilot tolerance: +0/-0.05 mm (+0/-0.002 in.).

QVFL AND QVVFL SQUARE FLANGE BLOCKS – STRAIGHT BORE EQUIVALENT

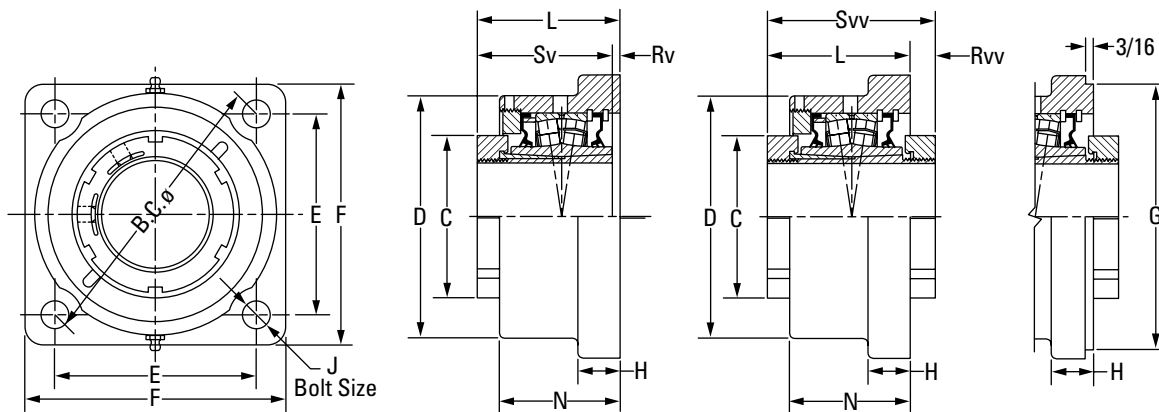

QV Single-Nut Unit⁽¹⁾

QVV Double-Nut Unit⁽¹⁾

Bearing Part No. ⁽¹⁾⁽²⁾	Shaft Dia.	Bearing No.	C	D	E	B.C.	F	G ⁽³⁾⁽⁴⁾⁽⁵⁾	H	J	L FIX	L EXP	N	Rv ⁽¹⁾	Rvv	Sv ⁽¹⁾	Svv	Wt.
	mm in.		mm in.	mm in.	mm in.	mm in.	mm in.	mm in.	mm in.	mm in.	mm in.	mm in.	mm in.	mm in.	mm in.	mm in.	mm in.	kg lbs.
QVFL11V115S QVVFL11V115S	1 1/16 in.	22211	75.9	115.3	103.4	146.1	131.8	N/A	23.1	12	82.6	84.6	61.2	2.5	19.8	79.8	102.1	5.0
QVFL11V200S QVVFL11V200S	2 in.		2.99	4.54	4.07	5.75	5.19		0.91	1/2	3.25	3.33	2.41	0.10	0.78	3.14	4.02	11
QVFL11V050S QVVFL11V050S	50 mm	22212	80.3	130.3	114.6	162.1	149.4	N/A	19.1	16	84.3	86.4	66.8	4.6	17.8	79.8	102.1	6.4
QVFL12V203S QVVFL12V203S	2 3/8 in.		3.16	5.13	4.51	6.38	5.88		0.75	5/8	3.32	3.40	2.63	0.18	0.70	3.14	4.02	14
QVFL12V204S QVVFL12V204S	2 1/4 in.	22214	94.0	146.1	121.2	171.5	157.2	N/A	25.4	16	86.1	88.1	72.6	5.1	15.2	81.0	101.3	7.7
QVFL12V055S QVVFL12V055S	55 mm		3.70	5.75	4.77	6.75	6.19		1.00	1	3.39	3.47	2.86	0.20	0.60	3.19	3.99	17
QVFL14V060S QVVFL14V060S	60 mm	22216	106.4	168.4	141.2	200.2	182.6	N/A	26.9	20	86.9	88.9	74.4	3.3	17.0	83.6	103.6	10.4
QVFL14V207S QVVFL14V207S	2 7/8 in.		4.19	6.63	5.56	7.88	7.19		1.06	3/4	3.42	3.50	2.93	0.13	0.67	3.29	4.08	23
QVFL14V208S QVVFL14V208S	2 1/2 in.	22216	106.4	168.4	141.2	200.2	182.6	N/A	26.9	20	86.9	88.9	74.4	3.3	17.0	83.6	103.6	10.4
QVFL14V065S QVVFL14V065S	65 mm		4.19	6.63	5.56	7.88	7.19		1.06	3/4	3.42	3.50	2.93	0.13	0.67	3.29	4.08	23
QVFL16V211S QVVFL16V211S	2 1/16 in.	22216	106.4	168.4	141.2	200.2	182.6	N/A	26.9	20	86.9	88.9	74.4	3.3	17.0	83.6	103.6	10.4
QVFL16V212S QVVFL16V212S	2 3/8 in.		4.19	6.63	5.56	7.88	7.19		1.06	3/4	3.42	3.50	2.93	0.13	0.67	3.29	4.08	23
QVFL16V070S QVVFL16V070S	70 mm	22216	106.4	168.4	141.2	200.2	182.6	N/A	26.9	20	86.9	88.9	74.4	3.3	17.0	83.6	103.6	10.4
QVFL16V215S QVVFL16V215S	2 1/16 in.		4.19	6.63	5.56	7.88	7.19		1.06	3/4	3.42	3.50	2.93	0.13	0.67	3.29	4.08	23
QVFL16V300S QVVFL16V300S	3 in.	22216	106.4	168.4	141.2	200.2	182.6	N/A	26.9	20	86.9	88.9	74.4	3.3	17.0	83.6	103.6	10.4
QVFL16V075S QVVFL16V075S	75 mm		4.19	6.63	5.56	7.88	7.19		1.06	3/4	3.42	3.50	2.93	0.13	0.67	3.29	4.08	23

⁽¹⁾Bearing part numbers use QV to designate single-nut units (uses Rv and Sv dimensions) and QVV to designate double-nut units (uses Rvv and Svv dimensions).

Continued on next page.

⁽²⁾Single-nut (QV) part number shown. Double-nut (QVV) version available upon request.

⁽³⁾Pilot tolerance: +0/-0.08 mm (+0/-0.003 in.).

⁽⁴⁾Add (p) to the end of the housing designation in the part number to order with pilot using G dimension.

⁽⁵⁾Piloted flange blocks will be quoted (price and delivery) upon request. For optional spigot on flange side, insert the letter P as seen in the following example: QMFP**J***S.

QVFL AND QVVFL SQUARE FLANGE BLOCKS – STRAIGHT BORE EQUIVALENT

– continued

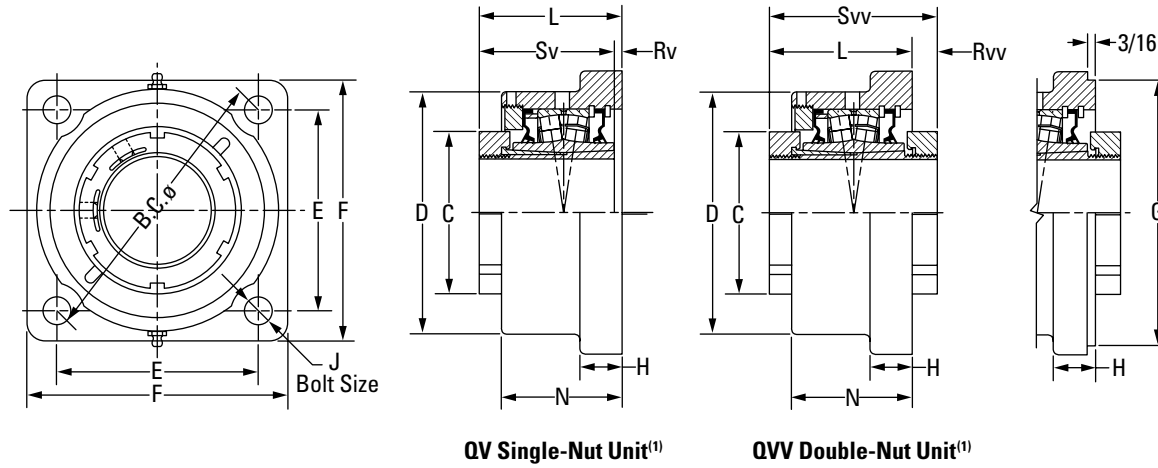

QV Single-Nut Unit⁽¹⁾

QVV Double-Nut Unit⁽¹⁾

Bearing Part No. ⁽¹⁾⁽²⁾	Shaft Dia.	Bearing No.	C	D	E	B.C.	F	G ⁽³⁾⁽⁴⁾⁽⁵⁾	H	J	L FIX	L EXP	N	Rv ⁽¹⁾	Rvv	Sv ⁽¹⁾	Svv	Wt.
	mm in.		mm in.	mm in.	mm in.	mm in.	mm in.	mm in.	mm in.	mm in.	mm in.	mm in.	mm in.	mm in.	mm in.	mm in.	mm in.	kg lbs.
QVFL19V303S QVFL19V303S	3 3/16 in.	22219	124.5	193.8	170.7	241.3	212.9	187.33	32.5	20	97.3	99.3	86.4	3.6	17.0	93.7	114.0	15.9
QVFL19V304S QVFL19V304S	3 1/4 in.																	
QVFL19V080S QVFL19V080S	80 mm																	
QVFL19V085S QVFL19V085S	85 mm																	
QVFL19V307S QVFL19V307S	3 7/16 in.																	
QVFL19V308S QVFL19V308S	3 1/2 in.																	
QVFL19V090S QVFL19V090S	90 mm																	
QVFL22V311S QVFL22V311S	3 11/16 in.	22222	139.7	229.6	193.0	273.1	241.3	215.90	38.1	24	116.8	118.9	104.6	11.9	9.9	104.9	126.7	24.9
QVFL22V312S QVFL22V312S	3 3/4 in.																	
QVFL22V100S QVFL22V100S	100 mm																	
QVFL22V315S QVFL22V315S	3 15/16 in.																	
QVFL22V400S QVFL22V400S	4 in.																	

⁽¹⁾Bearing part numbers use QV to designate single-nut units (uses Rv and Sv dimensions) and QVV to designate double-nut units (uses Rvv and Sv dimensions).

⁽²⁾Single-nut (QV) part number shown. Double-nut (QVV) version available upon request.

⁽³⁾Pilot tolerance: +0/-0.08 mm (+0/-0.003 in.).

⁽⁴⁾Add (p) to the end of the housing designation in the part number to order with pilot using G dimension.

⁽⁵⁾Piloted flange blocks will be quoted (price and delivery) upon request. For optional spigot on flange side, insert the letter P as seen in the following example: QMFP**J***S.

QVFX AND QVVFX 5000 SERIES SQUARE FLANGE BLOCKS – STRAIGHT BORE EQUIVALENT

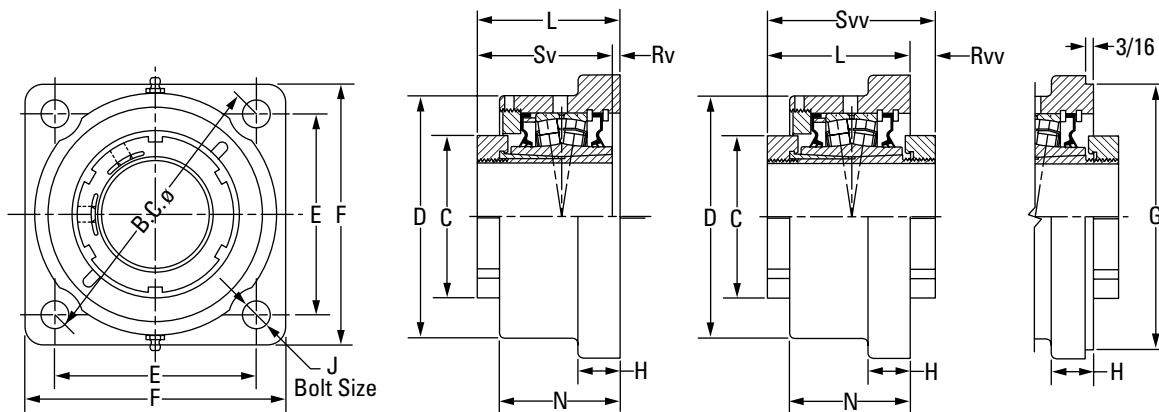

QV Single-Nut Unit⁽¹⁾

QVV Double-Nut Unit⁽¹⁾

Bearing Part No. ⁽¹⁾⁽²⁾	Shaft Dia.	Bearing No.	C	D	E	B.C.	F	G ⁽³⁾⁽⁴⁾⁽⁵⁾	H	J	L FIX	L EXP	N	Rv ⁽¹⁾	Rvv	Sv ⁽¹⁾	Svv	Wt.
	mm in.		mm in.	mm in.	mm in.	mm in.	mm in.	mm in.	mm in.	mm in.	mm in.	mm in.	mm in.	mm in.	mm in.	mm in.	mm in.	kg lbs.
QVFX11V115S QVVFX11V115S	1 1/8 in.	22211	75.9	120.7	103.6	146.1	134.9	111.13	22.4	12	84.1	86.1	65.0	4.1	18.3	79.8	102.1	5.0
QVFX11V200S QVVFX11V200S	2 in.		2.99	4.75	4.08	5.75	5.31	4.375	0.88	1/2	3.31	3.39	2.56	0.16	0.72	3.14	4.02	11
QVFX11V050S QVVFX11V050S	50 mm	22212	80.3	130.3	114.3	161.5	149.4	127.00	25.4	16	84.3	86.4	66.8	4.6	17.5	79.8	102.1	6.4
QVFX12V203S QVVFX12V203S	2 3/8 in.		3.16	5.13	4.50	6.36	5.88	5.000	1.00	5/8	3.32	3.40	2.63	0.18	0.69	3.14	4.02	14
QVFX12V204S QVVFX12V204S	2 1/4 in.	22214	94.0	146.1	127.8	180.8	157.2	138.13	25.4	16	85.1	87.4	72.4	4.1	16.0	81.0	101.3	7.7
QVFX12V055S QVVFX12V055S	55 mm		3.70	5.75	5.03	7.12	6.19	5.438	1.00	5/8	3.35	3.44	2.85	0.16	0.63	3.19	3.99	17
QVFX14V060S QVVFX14V060S	60 mm	22216	106.4	168.9	152.7	215.9	189.0	160.35	26.9	20	87.6	89.7	76.2	4.1	16.3	83.6	103.6	10.4
QVFX14V207S QVVFX14V207S	2 7/8 in.		4.19	6.65	6.01	8.50	7.44	6.313	1.06	3/4	3.45	3.53	3.00	0.16	0.64	3.29	4.08	23
QVFX14V208S QVVFX14V208S	2 1/2 in.	22216	106.4	168.9	152.7	215.9	189.0	160.35	26.9	20	87.6	89.7	76.2	4.1	16.3	83.6	103.6	10.4
QVFX14V065S QVVFX14V065S	65 mm		4.19	6.65	6.01	8.50	7.44	6.313	1.06	3/4	3.45	3.53	3.00	0.16	0.64	3.29	4.08	23
QVFX16V211S QVVFX16V211S	2 1/8 in.	22216	106.4	168.9	152.7	215.9	189.0	160.35	26.9	20	87.6	89.7	76.2	4.1	16.3	83.6	103.6	10.4
QVFX16V212S QVVFX16V212S	2 3/4 in.		4.19	6.65	6.01	8.50	7.44	6.313	1.06	3/4	3.45	3.53	3.00	0.16	0.64	3.29	4.08	23
QVFX16V070S QVVFX16V070S	70 mm	22216	106.4	168.9	152.7	215.9	189.0	160.35	26.9	20	87.6	89.7	76.2	4.1	16.3	83.6	103.6	10.4
QVFX16V215S QVVFX16V215S	2 1/8 in.		4.19	6.65	6.01	8.50	7.44	6.313	1.06	3/4	3.45	3.53	3.00	0.16	0.64	3.29	4.08	23
QVFX16V300S QVVFX16V300S	3 in.	22216	106.4	168.9	152.7	215.9	189.0	160.35	26.9	20	87.6	89.7	76.2	4.1	16.3	83.6	103.6	10.4
QVFX16V075S QVVFX16V075S	75 mm		4.19	6.65	6.01	8.50	7.44	6.313	1.06	3/4	3.45	3.53	3.00	0.16	0.64	3.29	4.08	23

⁽¹⁾Bearing part numbers use QV to designate single-nut units (uses Rv and Sv dimensions) and QVV to designate double-nut units (uses Rvv and Svv dimensions).

Continued on next page.

⁽²⁾Single-nut (QV) part number shown. Double-nut (QVV) version available upon request.

⁽³⁾Pilot tolerance: +0/-0.05 mm (+0/-0.002 in.).

⁽⁴⁾Add (p) to the end of the housing designation in the part number to order with pilot using G dimension.

⁽⁵⁾Piloted flange blocks will be quoted (price and delivery) upon request. For optional spigot on flange side, insert the letter P as seen in the following example: QMFP**J***S.

⁽⁶⁾Six-bolt round housing.

QVFX AND QVFX 5000 SERIES SQUARE FLANGE BLOCKS – STRAIGHT BORE EQUIVALENT – continued

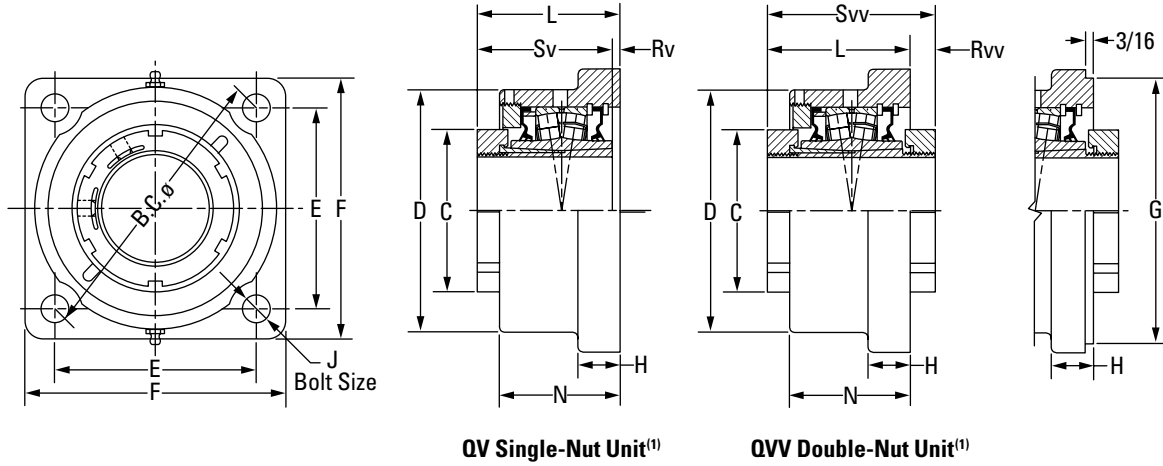

QV Single-Nut Unit⁽¹⁾

QVV Double-Nut Unit⁽¹⁾

Bearing Part No. ⁽¹⁾⁽²⁾	Shaft Dia.	Bearing No.	C	D	E	B.C.	F	G ⁽³⁾⁽⁴⁾⁽⁵⁾	H	J	L FIX	L EXP	N	Rv ⁽¹⁾	Rvv	Sv ⁽¹⁾	Svv	Wt.
	mm in.		mm in.	mm in.	mm in.	mm in.	mm in.	mm in.	mm in.	mm in.	mm in.	mm in.	mm in.	mm in.	mm in.	mm in.	mm in.	kg lbs.
QVFX19V303S QVFX19V303S	3 3/8 in.	22219	124.5	193.8	170.7	241.3	212.6	187.33	33.3	20	98.3	100.6	84.1	4.8	15.7	93.7	114.0	15.9
QVFX19V304S QVFX19V304S	3 1/4 in.																	
QVFX19V080S QVFX19V080S	80 mm																	
QVFX19V085S QVFX19V085S	85 mm																	
QVFX19V307S QVFX19V307S	3 7/8 in.																	
QVFX19V308S QVFX19V308S	3 1/2 in.																	
QVFX19V090S QVFX19V090S	90 mm	22222	139.7	235.0	211.1	298.5	268.2	225.43	38.1	24	114.0	116.3	100.6	9.4	12.7	104.9	126.7	24.9
QVFX22V311S QVFX22V311S	3 11/16 in.																	
QVFX22V312S QVFX22V312S	3 3/4 in.																	
QVFX22V100S QVFX22V100S	100 mm																	
QVFX22V315S QVFX22V315S	3 15/16 in.																	
QVFX22V400S QVFX22V400S	4 in.																	
QVFX26V110S ⁽⁶⁾ QVFX26V110S ⁽⁶⁾	110 mm	22226	174.8	254.0	163.6	327.2	384.3	263.53	38.1	24	140.5	142.7	106.9	7.4	37.8	147.8	178.3	49.0
QVFX26V407S ⁽⁶⁾ QVFX26V407S ⁽⁶⁾	4 7/8 in.																	
QVFX26V408S ⁽⁶⁾ QVFX26V408S ⁽⁶⁾	4 1/2 in.																	
QVFX26V115S ⁽⁶⁾ QVFX26V115S ⁽⁶⁾	115 mm																	
QVFX28V125S ⁽⁶⁾ QVFX28V125S ⁽⁶⁾	125 mm	22228	190.0	284.2	177.8	355.6	419.1	284.18	38.1	24	166.1	168.1	138.4	18.3	12.2	147.8	178.3	52.2
QVFX28V415S ⁽⁶⁾ QVFX28V415S ⁽⁶⁾	4 15/16 in.																	
QVFX28V500S ⁽⁶⁾ QVFX28V500S ⁽⁶⁾	5 in.																	
QVFX28V130S ⁽⁶⁾ QVFX28V130S ⁽⁶⁾	130 mm																	

⁽¹⁾Bearing part numbers use QV to designate single-nut units (uses Rv and Sv dimensions) and QVV to designate double-nut units (uses Rvv and Svv dimensions).

⁽²⁾Single-nut (QV) part number shown. Double-nut (QVV) version available upon request.

⁽³⁾Pilot tolerance: +0/-0.05 mm (+0/-0.002 in.).

⁽⁴⁾Add (p) to the end of the housing designation in the part number to order with pilot using G dimension.

⁽⁵⁾Piloted flange blocks will be quoted (price and delivery) upon request. For optional spigot on flange side, insert the letter P as seen in the following example: QMFP**J***S.

⁽⁶⁾Six-bolt round housing.

QVFK AND QVVK 9000 SERIES SQUARE FLANGE BLOCKS – TAPERED BORE EQUIVALENT

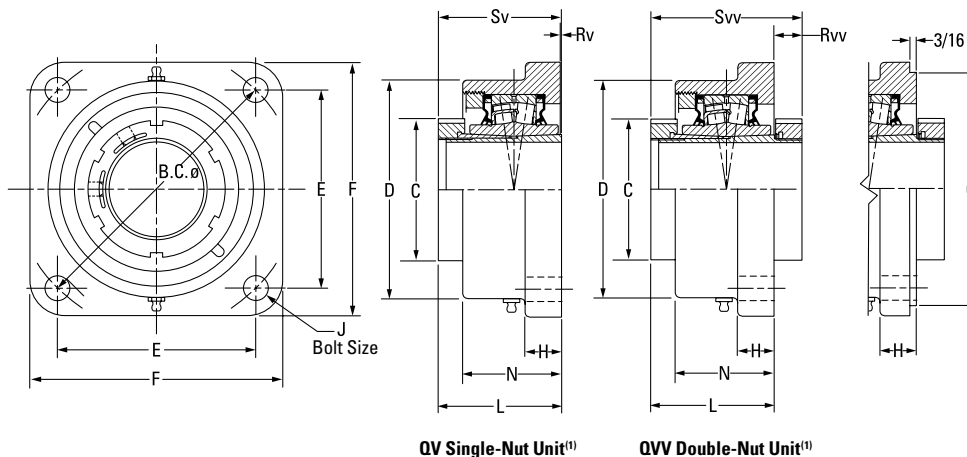

Bearing Part No. ⁽¹⁾⁽²⁾	Shaft Dia.	Bearing No.	C	D	E	B.C.	F	G ⁽³⁾⁽⁴⁾⁽⁵⁾	H	J	L FIX	L EXP	N	Rv ⁽¹⁾	Rvv	Sv ⁽¹⁾	Svv	Wt.
	mm in.		mm in.	mm in.	mm in.	mm in.	mm in.	mm in.	mm in.	mm in.	mm in.	mm in.	mm in.	mm in.	mm in.	mm in.	mm in.	kg lbs.
QVFK11V115S QVVK11V115S	1 15/16 in.	22211	75.9	130.3	114.3	161.5	149.4	127.00	19.1	16	87.1	88.4	66.8	7.4	15.0	79.8	102.1	5.0
QVFK11V200S QVVK11V200S	2 in.		2.99	5.13	4.50	6.36	5.88	5.000	0.75	5/8	3.43	3.48	2.63	0.29	0.59	3.14	4.02	11
QVFK11V050S QVVK11V050S	50 mm	22213	80.3	146.1	127.8	180.8	157.2	138.13	25.4	16	92.2	94.2	72.4	6.9	15.5	85.3	107.7	6.4
QVFK13V203S QVVK13V203S	2 3/16 in.		3.16	5.75	5.03	7.12	6.19	5.438	1.00	5/8	3.63	3.71	2.85	0.27	0.61	3.36	4.24	14
QVFK13V204S QVVK13V204S	2 1/4 in.	22215	94.0	168.9	152.7	215.9	189.0	160.35	26.9	20	92.5	94.5	76.2	9.9	11.4	82.6	103.9	7.7
QVFK13V055S QVVK13V055S	55 mm		3.70	6.65	6.01	8.50	7.44	6.313	1.06	3/4	3.64	3.72	3.00	0.39	0.45	3.25	4.09	17
QVFK15V060S QVVK15V060S	60 mm	22217	106.4	193.8	170.7	241.3	212.9	187.33	33.3	20	92.5	101.1	84.1	14.5	7.1	84.6	106.2	10.4
QVFK15V207S QVVK15V207S	2 7/16 in.		4.19	7.63	6.72	9.50	8.38	7.375	1.31	3/4	3.64	3.98	3.31	0.57	0.28	3.33	4.18	23
QVFK17V211S QVVK17V211S	2 11/16 in.	22217	106.4	193.8	170.7	241.3	212.9	187.33	33.3	20	92.5	101.1	84.1	14.5	7.1	84.6	106.2	10.4
QVFK17V212S QVVK17V212S	2 3/4 in.		4.19	7.63	6.72	9.50	8.38	7.375	1.31	3/4	3.64	3.98	3.31	0.57	0.28	3.33	4.18	23
QVFK17V070S QVVK17V070S	70 mm	22217	106.4	193.8	170.7	241.3	212.9	187.33	33.3	20	92.5	101.1	84.1	14.5	7.1	84.6	106.2	10.4
QVFK17V215S QVVK17V215S	2 15/16 in.		4.19	7.63	6.72	9.50	8.38	7.375	1.31	3/4	3.64	3.98	3.31	0.57	0.28	3.33	4.18	23
QVFK17V300S QVVK17V300S	3 in.	22217	106.4	193.8	170.7	241.3	212.9	187.33	33.3	20	92.5	101.1	84.1	14.5	7.1	84.6	106.2	10.4
QVFK17V075S QVVK17V075S	75 mm		4.19	7.63	6.72	9.50	8.38	7.375	1.31	3/4	3.64	3.98	3.31	0.57	0.28	3.33	4.18	23

⁽¹⁾Bearing part numbers use QV to designate single-nut units (uses Rv and Sv dimensions) and QVV to designate double-nut units (uses Rvv and Sv dimensions).
⁽²⁾Single-nut (QV) part number shown. Double-nut (QVV) version available upon request.
⁽³⁾Pilot tolerance: +0/-0.05 mm (+0/-0.002 in.).
⁽⁴⁾Add (p) to the end of the housing designation in the part number to order with pilot using G dimension.
⁽⁵⁾Piloted flange blocks will be quoted (price and delivery) upon request. For optional spigot on flange side, insert the letter P as seen in the following example: QMFP**J***S.
⁽⁶⁾Six-bolt round housing.

Continued on next page.

QVFK AND QVVK 9000 SERIES SQUARE FLANGE BLOCKS – TAPERED BORE EQUIVALENT – continued

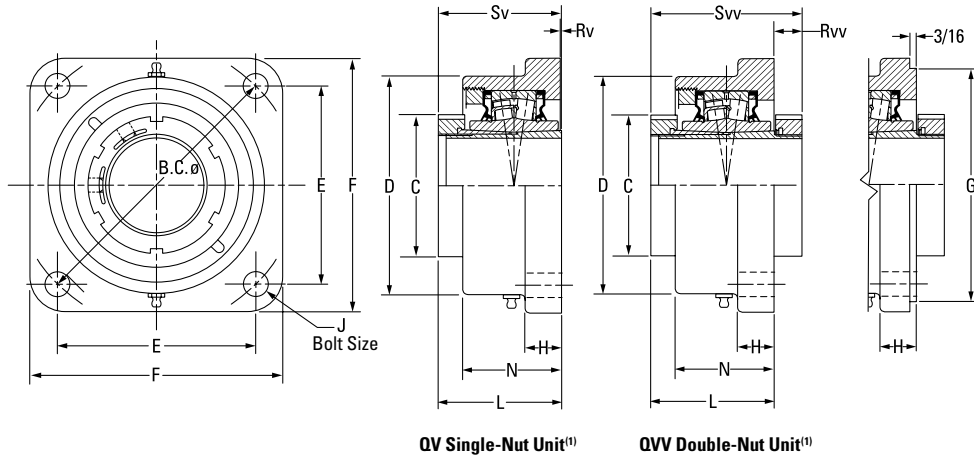

Bearing Part No. ⁽¹⁾⁽²⁾	Shaft Dia.	Bearing No.	C	D	E	B.C.	F	G ⁽³⁾⁽⁴⁾⁽⁵⁾	H	J	L FIX	L EXP	N	Rv ⁽¹⁾	Rvv	Sv ⁽¹⁾	Svv	Wt.
	mm in.		mm in.	mm in.	mm in.	mm in.	mm in.	mm in.	mm in.	mm in.	mm in.	mm in.	mm in.	mm in.	mm in.	mm in.	mm in.	kg lbs.
QVFK20V303S QVVK20V303S	3 3/8 in.	22220	124.5 4.90	215.9 8.50	211.1 8.31	298.5 11.75	268.2 10.56	225.43 8.875	38.1 1.50	24 7/8	113.3 4.46	115.3 4.54	103.1 4.06	18.0 0.71	4.1 0.16	95.3 3.75	117.3 4.62	15.9 35
QVFK20V304S QVVK20V304S	3 1/4 in.																	
QVFK20V080S QVVK20V080S	80 mm																	
QVFK20V085S QVVK20V085S	85 mm																	
QVFK20V307S QVVK20V307S	3 7/8 in.																	
QVFK20V308S QVVK20V308S	3 1/2 in.																	
QVFK20V090S QVVK20V090S	90 mm																	
QVFK22V311S ⁽⁶⁾ QVVK22V311S ⁽⁶⁾	3 1/16 in.	22222	139.7 5.50	254.0 10.00	163.6 6.44 ⁽⁶⁾	327.2 12.88 ⁽⁶⁾	384.3 15.13	263.53 10.375	31.8 1.25	24 1 ⁽⁶⁾	117.3 4.62	119.4 4.70	106.9 4.21	12.4 0.49	9.7 0.38	104.9 4.13	126.7 4.99	24.9 55
QVFK22V312S ⁽⁶⁾ QVVK22V312S ⁽⁶⁾	3 3/8 in.																	
QVFK22V100S ⁽⁶⁾ QVVK22V100S ⁽⁶⁾	100 mm																	
QVFK22V315S ⁽⁶⁾ QVVK22V315S ⁽⁶⁾	3 15/16 in.																	
QVFK22V400S ⁽⁶⁾ QVVK22V400S ⁽⁶⁾	4 in.																	
QVFK26V110S ⁽⁶⁾ QVVK26V110S ⁽⁶⁾	110 mm	22226	174.8 6.88	284.2 11.19	177.8 7.00 ⁽⁶⁾	355.6 14.00 ⁽⁶⁾	419.1 16.50	284.18 11.188	38.1 1.50	24 1 ⁽⁶⁾	164.6 6.48	166.6 6.56	135.1 5.32	11.7 0.46	13.7 0.54	147.8 5.82	178.3 7.02	49.0 108
QVFK26V407S ⁽⁶⁾ QVVK26V407S ⁽⁶⁾	4 7/8 in.																	
QVFK26V408S ⁽⁶⁾ QVVK26V408S ⁽⁶⁾	4 1/2 in.																	
QVFK26V115S ⁽⁶⁾ QVVK26V115S ⁽⁶⁾	115 mm																	

⁽¹⁾Bearing part numbers use QV to designate single-nut units (uses Rv and Sv dimensions) and QVV to designate double-nut units (uses Rvv and Svv dimensions).

⁽²⁾Single-nut (QV) part number shown. Double-nut (QVV) version available upon request.

⁽³⁾Pilot tolerance: +0/-0.05 mm (+0/-0.002 in.).

⁽⁴⁾Add (p) to the end of the housing designation in the part number to order with pilot using G dimension.

⁽⁵⁾Piloted flange blocks will be quoted (price and delivery) upon request. For optional spigot on flange side, insert the letter P as seen in the following example: QMFP**J***S.

⁽⁶⁾Six-bolt round housing.

QVFNL SERIES SQUARE FLANGE BLOCKS – STRAIGHT BORE EQUIVALENT

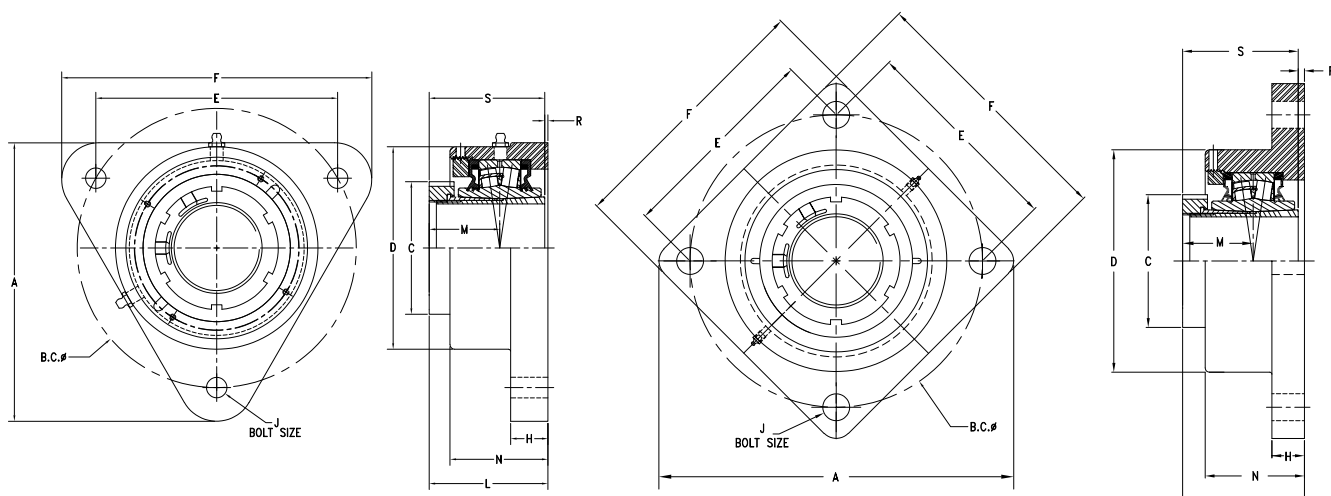

Bearing Part No. ⁽¹⁾⁽²⁾	Shaft Dia.	Bearing No.	A	B.C	C	D	E	F	H	J	L	M	N	R	S	Wt.
	mm in.		mm in.	mm in.	mm in.	mm in.	mm in.	mm in.	mm in.	mm in.	mm in.	mm in.	mm in.	mm in.	mm in.	kg lbs.
QVFNL11V050S QVFNL11V115S QVFNL11V200S	50 mm 1 15/16 in. 2 in.	22211	172.3 6.78	170.0 6.69	76.0 2.99	121.9 4.80	147.2 5.80	192.0 7.56	15 0.59	12 1/2	80.8 3.18	51.10 2.01	60.0 2.63	0.4 0.01	80.5 3.17	5.0 11
QVFNL12V055S	55 mm	22212	173.2 6.82	180.0 7.09	80.3 3.16	127.0 5.00	155.9 6.14	210.0 8.27	15 .059	12 1/2	81.5 3.21	51.00 2.01	59.0 2.32	0.5 0.02	81.0 3.19	5.4 11.9
QVFNL13V203S QVFNL13V204S	2 3/8 in. 2 1/2 in.	22213	200.2 7.88	190.0 7.48	80.3 3.16	137.8 5.43	164.5 6.48	223.3 8.79	15 .059	12 1/2	84.1 3.31	51.90 2.04	66.6 2.62	3.3 0.13	80.8 3.18	6.3 13.9
QVFNL15V065S QVFNL15V207S QVFNL15V208S	65 mm 2 7/16 in. 2 1/2 in.	22215	258.2 10.16	215.0 8.46	94.0 3.70	169.9 6.69	152.0 5.98	190.0 7.48	25 0.98	16 5/8	83.3 3.28	50.55 1.99	65.4 2.58	0.4 0.01	83.1 3.27	11.3 25.0
QVFNL16V070S QVFNL16V211S QVFNL16V212S	70 mm 2 13/16 in. 2 3/4 in.	22216	258.2 10.16	215.0 8.46	106.4 4.19	170.0 6.69	152.0 5.98	190.0 7.48	25 0.98	16 5/8	83.8 3.30	51.90 2.04	65.4 2.58	0.4 0.01	83.6 3.29	13.6 30.0
QVFNL17V075S QVFNL17V215S QVFNL17V300S	75 mm 2 15/16 in. 3 in.	22217	279.4 11.00	240.4 9.47	106.4 4.19	190.0 7.48	170.0 6.69	210.0 8.27	25 0.98	16 5/8	89.9 3.54	52.90 2.08	73.1 2.88	5.2 0.21	84.6 3.33	13.6 30.0
QVFNL19V080S QVFNL19V303S QVFNL19304S	80 mm 3 1/8 in. 3 1/4 in.	22219	279.4 11.00	240.4 9.47	124.5 4.90	190.0 7.48	170.0 6.69	210.0 8.27	25 0.98	16 5/8	98.8 3.89	57.20 2.25	73.1 2.88	5.1 0.20	93.7 3.69	13.6 30.0
QVFNL20V090S QVFNL20V307S QVFNL20V308S	90 mm 3 5/16 in. 3 1/2 in.	22220	332.5 13.09	279.9 11.02	124.5 4.90	198.1 7.80	197.9 7.79	250.0 9.84	30 1.18	20 3/4	102.1 4.02	58.70 2.31	90.8 3.58	7.1 0.28	95.0 3.74	18.1 40.0
QVFNL22V100S QVFNL22V311S QVFNL22V312S QVFNL22V315S QVFNL22V400S	100 mm 3 15/16 in. 3 3/4 in. 3 5/8 in. 4 in.	22222	360.8 14.21	309.9 12.2	139.7 5.50	218.4 8.60	219.1 8.63	270.0 10.63	30 1.18	20 3/4	113.0 4.45	63.40 2.50	99.6 3.92	8.2 0.32	104.9 4.13	27.2 60.0

⁽¹⁾Bearing part numbers use QV to designate single-nut units (uses Rv and Sv dimensions) and QVV to designate double-nut units (uses Rvv and Svv dimensions).

⁽²⁾Single-nut (QV) part number shown. Double-nut (QVV) version available upon request.

QVfy AND QVfy ROUND FLANGE BLOCKS – STRAIGHT BORE EQUIVALENT

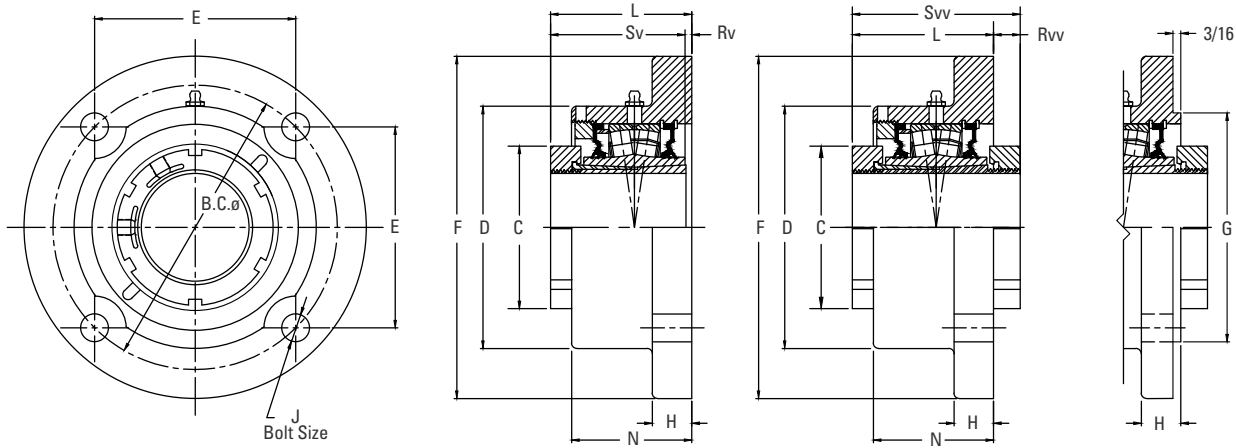

Bearing Part No. ⁽¹⁾⁽²⁾	Shaft Dia.	Bearing No.	C	D	E	B.C.	F	G ⁽³⁾⁽⁴⁾⁽⁵⁾	H	J	L FIX	L EXP	N	Rv ⁽¹⁾	Rvv	Sv ⁽¹⁾	Svv	Wt.
			mm in.	mm in.	mm in.	mm in.	mm in.	mm in.	mm in.	mm in.	mm in.	mm in.	mm in.	mm in.	mm in.	mm in.	mm in.	mm in.
QVfy11V115S QVfy11V115S	1 15/16 in.	22211	75.9	115.3	103.4	146.1	177.8	111.13	19.1	12	78.5	80.5	58.4	1.5	23.9	79.8	102.1	5.4
QVfy11V200S QVfy11V200S	2 in.		2.99	4.54	4.07	5.75	7.00	4.375	0.75	1/2	3.09	3.17	2.30	0.06	0.94	3.14	4.02	12
QVfy11V050S QVfy11V050S	50 mm	22212	80.3	130.3	114.6	162.1	196.9	127.00	19.1	16	80.0	82.0	62.0	0.3	22.1	79.8	102.1	6.8
QVfy12V203S QVfy12V203S	2 3/16 in.		3.16	5.13	4.51	6.38	7.75	5.000	0.75	5/8	3.15	3.23	2.44	0.01	0.87	3.14	4.02	15
QVfy12V204S QVfy12V204S	2 1/4 in.	22214	94.0	146.1	121.2	171.5	206.5	138.13	23.9	16	84.8	86.9	72.4	3.8	16.5	81.0	101.3	8.6
QVfy12V055S QVfy12V055S	55 mm		3.70	5.75	4.77	6.75	8.13	5.438	0.94	5/8	3.34	3.42	2.85	0.15	0.65	3.19	3.99	19
QVfy14V060S QVfy14V060S	60 mm	22216	106.4	168.4	141.5	199.9	241.3	160.35	23.9	20	88.4	90.4	76.2	4.8	15.2	83.6	103.6	12.7
QVfy14V207S QVfy14V207S	2 7/16 in.		4.19	6.63	5.57	7.87	9.50	6.313	0.94	3/4	3.48	3.56	3.00	0.19	0.60	3.29	4.08	28
QVfy14V208S QVfy14V208S	2 1/2 in.	22216	106.4	168.4	141.5	199.9	241.3	160.35	23.9	20	88.4	90.4	76.2	4.8	15.2	83.6	103.6	12.7
QVfy14V065S QVfy14V065S	65 mm		4.19	6.63	5.57	7.87	9.50	6.313	0.94	3/4	3.48	3.56	3.00	0.19	0.60	3.29	4.08	28
QVfy16V211S QVfy16V211S	2 11/16 in.	22216	106.4	168.4	141.5	199.9	241.3	160.35	23.9	20	88.4	90.4	76.2	4.8	15.2	83.6	103.6	12.7
QVfy16V212S QVfy16V212S	2 3/4 in.		4.19	6.63	5.57	7.87	9.50	6.313	0.94	3/4	3.48	3.56	3.00	0.19	0.60	3.29	4.08	28
QVfy16V070S QVfy16V070S	70 mm	22216	106.4	168.4	141.5	199.9	241.3	160.35	23.9	20	88.4	90.4	76.2	4.8	15.2	83.6	103.6	12.7
QVfy16V215S QVfy16V215S	2 15/16 in.		4.19	6.63	5.57	7.87	9.50	6.313	0.94	3/4	3.48	3.56	3.00	0.19	0.60	3.29	4.08	28
QVfy16V300S QVfy16V300S	3 in.	22216	106.4	168.4	141.5	199.9	241.3	160.35	23.9	20	88.4	90.4	76.2	4.8	15.2	83.6	103.6	12.7
QVfy16V075S QVfy16V075S	75 mm		4.19	6.63	5.57	7.87	9.50	6.313	0.94	3/4	3.48	3.56	3.00	0.19	0.60	3.29	4.08	28

⁽¹⁾Bearing part numbers use QV to designate single-nut units (uses Rv and Sv dimensions) and QVV to designate double-nut units (uses Rvv and Svv dimensions).

⁽²⁾Single-nut (QV) part number shown. Double-nut (QVV) version available upon request.

⁽³⁾Pilot tolerance: +0/-0.05 mm (+0/-0.002 in.).

⁽⁴⁾Add (p) to the end of the housing designation in the part number to order with pilot using G dimension.

⁽⁵⁾Piloted flange blocks will be quoted (price and delivery) upon request. For optional spigot on flange side, insert the letter P as seen in the following example: QMFP**J***S.

⁽⁶⁾Six-bolt round housing.

QVfy AND QVfyfY ROUND FLANGE BLOCKS – STRAIGHT BORE EQUIVALENT

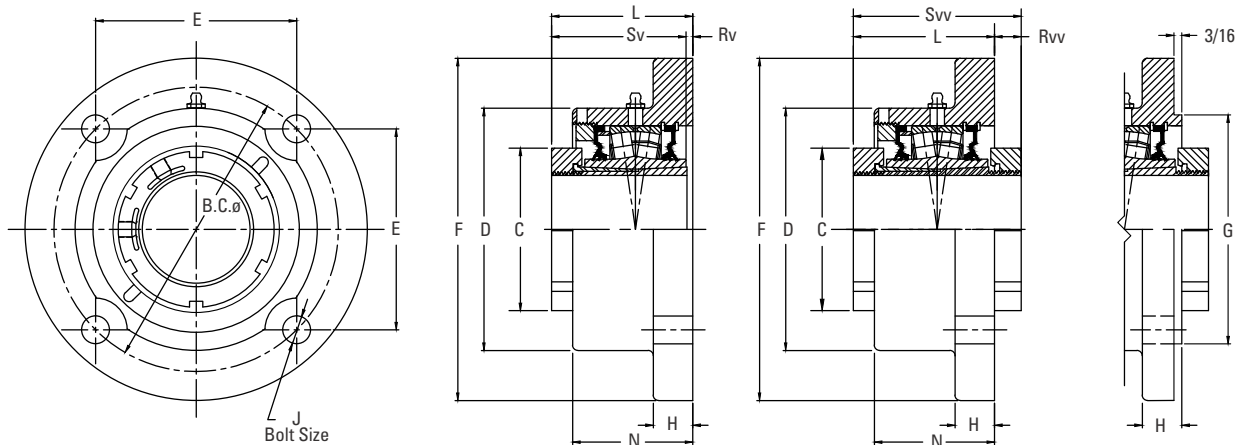

Bearing Part No. ⁽¹⁾⁽²⁾	Shaft Dia.	Bearing No.	C	D	E	B.C.	F	G ⁽³⁾⁽⁴⁾⁽⁵⁾	H	J	L FIX	L EXP	N	Rv ⁽¹⁾	RvV	Sv ⁽¹⁾	SvV	Wt.
	mm in.		mm in.	mm in.	mm in.	mm in.	mm in.	mm in.	mm in.	mm in.	mm in.	mm in.	mm in.	mm in.	mm in.	mm in.	mm in.	kg lbs.
QVfy19V303S QVfyfY19V303S	3 3/16 in.	22219	124.5 4.90	193.8 7.63	170.7 6.72	241.3 9.50	282.7 11.13	187.33 7.375	28.7 1.13	24 7/8	98.3 3.87	116.1 4.57	85.3 3.36	4.8 0.19	15.7 0.62	93.7 3.69	114.0 4.49	19.1 42
QVfy19V304S QVfyfY19V304S	3 1/4 in.																	
QVfy19V080S QVfyfY19V080S	80 mm																	
QVfy19V085S QVfyfY19V085S	85 mm																	
QVfy19V307S QVfyfY19V307S	3 7/16 in.																	
QVfy19V308S QVfyfY19V308S	3 1/2 in.																	
QVfy19V090S QVfyfY19V090S	90 mm																	
QVfy22V311S QVfyfY22V311S	3 11/16 in.																	
QVfy22V312S QVfyfY22V312S	3 3/4 in.																	
QVfy22V100S QVfyfY22V100S	100 mm																	
QVfy22V315S QVfyfY22V315S	3 15/16 in.																	
QVfy22V400S QVfyfY22V400S	4 in.																	
QVfy26V110S ⁽⁶⁾ QVfyfY26V110S ⁽⁶⁾	110 mm	22226	174.8 6.88	230.1 9.06	163.6 6.44 ⁽⁶⁾	327.2 12.88 ⁽⁶⁾	384.3 15.13	N/A	38.1 1.50	24 1 ⁽⁶⁾	140.5 5.53	142.7 5.62	106.9 4.21	7.4 0.29	37.8 1.49	147.8 5.82	178.3 7.02	49.0 108
QVfy26V407S ⁽⁶⁾ QVfyfY26V407S ⁽⁶⁾	4 7/16 in.																	
QVfy26V408S ⁽⁶⁾ QVfyfY26V408S ⁽⁶⁾	4 1/2 in.																	
QVfy26V115S ⁽⁶⁾ QVfyfY26V115S ⁽⁶⁾	115 mm																	
QVfy28V125S ⁽⁶⁾ QVfyfY28V125S ⁽⁶⁾	125 mm	22228	190.0 7.48	284.2 11.19	177.8 7.00 ⁽⁶⁾	355.6 14.00 ⁽⁶⁾	419.1 16.50	N/A	38.1 1.50	24 1 1/8 ⁽⁶⁾	166.1 6.54	168.1 6.62	138.4 5.45	18.3 0.72	12.2 0.48	147.8 5.82	178.3 7.02	52.2 115
QVfy28V415S ⁽⁶⁾ QVfyfY28V415S ⁽⁶⁾	4 15/16 in.																	
QVfy28V500S ⁽⁶⁾ QVfyfY28V500S ⁽⁶⁾	5 in.																	
QVfy28V130S ⁽⁶⁾ QVfyfY28V130S ⁽⁶⁾	130 mm																	

⁽¹⁾Bearing part numbers use QV to designate single-nut units (uses Rv and Sv dimensions) and QVv to designate double-nut units (uses RvV and SvV dimensions).

⁽²⁾Single-nut (QV) part number shown. Double-nut (QVv) version available upon request.

⁽³⁾Pilot tolerance: +0/-0.05 mm (+0/-0.002 in.).

⁽⁴⁾Add (p) to the end of the housing designation in the part number to order with pilot using G dimension.

⁽⁵⁾Piloted flange blocks will be quoted (price and delivery) upon request. For optional spigot on flange side, insert the letter P as seen in the following example: QMFP**J***S.

⁽⁶⁾Six-bolt round housing.

QVC AND QVVC PILOTED FLANGE CARTRIDGES – STRAIGHT BORE EQUIVALENT

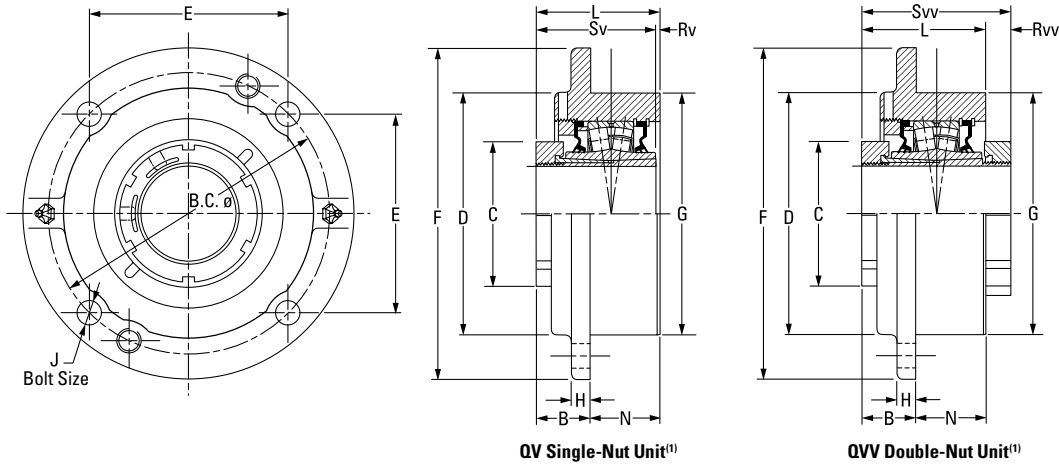

Bearing Part No. ⁽¹⁾⁽²⁾	Shaft Dia.	Bearing No.	B FIX	B EXP	C	D	B.C.	E	F	G ⁽³⁾	H	J	L	N	Rv ⁽¹⁾	Rvv	Sv ⁽¹⁾	Svv	Wt.
			mm in.	mm in.	mm in.	mm in.	mm in.	mm in.	mm in.	mm in.	mm in.	mm in.	mm in.	mm in.	mm in.	mm in.	mm in.	mm in.	mm in.
QVC11V115S QVVC11V115S	1 1/8 in.	22211	53.8	55.9	75.9	113.5	136.7	96.5	162.1	114.3	16.0	10	80.8	26.9	0.8	21.6	79.8	102.1	4.5
QVC11V200S QVVC11V200S	2 in.		2.12	2.20	2.99	4.47	5.38	3.80	6.38	4.50	0.63	7/16	3.18	1.06	0.03	0.85	3.14	4.02	10
QVC11V050S QVVC11V050S	50 mm																		
QVC12V203S QVVC12V203S	2 3/8 in.	22212	51.3	53.3	80.3	127.0	152.4	107.7	185.4	127.0	14.7	12	80.0	28.7	0.3	22.1	79.8	102.1	5.9
QVC12V204S QVVC12V204S	2 1/4 in.		2.02	2.10	3.16	5.00	6.00	4.24	7.30	5.00	0.58	1/2	3.15	1.13	0.01	0.87	3.14	4.02	13
QVC12V055S QVVC12V055S	55 mm																		
QVC14V060S QVVC14V060S	60 mm	22214	56.1	58.2	94.0	139.7	165.1	116.8	193.8	139.7	17.5	12	84.6	28.7	3.8	16.5	81.0	101.3	7.3
QVC14V207S QVVC14V207S	2 7/8 in.		2.21	2.29	3.70	5.50	6.50	4.60	7.63	5.50	0.69	1/2	3.33	1.13	0.15	0.65	3.19	3.99	16
QVC14V208S QVVC14V208S	2 1/2 in.																		
QVC14V065S QVVC14V065S	65 mm																		
QVC16V211S QVVC16V211S	2 11/16 in.	22216	52.8	54.9	106.4	162.1	190.5	134.6	222.3	161.9	20.6	16	84.6	31.8	1.0	19.3	83.6	103.6	10.0
QVC16V212S QVVC16V212S	2 3/4 in.																		
QVC16V070S QVVC16V070S	70 mm																		
QVC16V215S QVVC16V215S	2 15/16 in.																		
QVC16V300S QVVC16V300S	3 in.																		
QVC16V075S QVVC16V075S	75 mm																		

⁽¹⁾Bearing part numbers use QV to designate single-nut units (uses Rv and Sv dimensions) and QVV to designate double-nut units (uses Rvv and Svv dimensions).
⁽²⁾Single-nut (QV) part number shown. Double-nut (QVV) version available upon request.
⁽³⁾Pilot tolerance: +0/-0.05 mm (+0/-0.002 in.).
⁽⁴⁾Six-bolt round housing.

QVC AND QVVC PILOTED FLANGE CARTRIDGES – STRAIGHT BORE EQUIVALENT

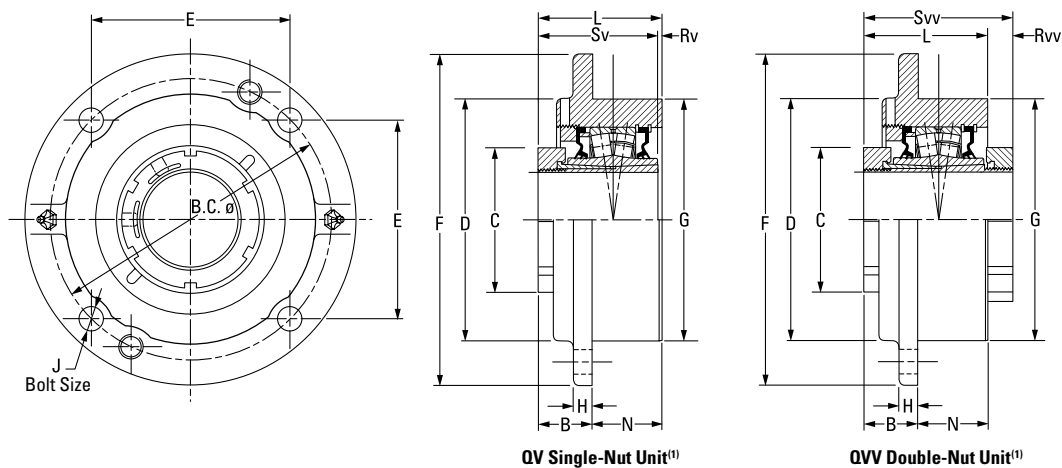

Bearing Part No. ⁽¹⁾⁽²⁾	Shaft Dia.	Bearing No.	B FIX	B EXP	C	D	B.C.	E	F	G ⁽³⁾	H	J	L	N	Rv ⁽¹⁾	Rvv	Sv ⁽¹⁾	Svv	Wt.	
	mm in.		mm in.	mm in.	mm in.	mm in.	mm in.	mm in.	mm in.	mm in.	mm in.	mm in.	mm in.	mm in.	mm in.	mm in.	mm in.	mm in.	mm in.	kg lbs.
QVC19V303S QVVC19V303S	3 3/16 in.	22219	62.5	64.5	124.5	199.1	219.2	154.9	262.6	187.3	25.4	20	95.8	33.3	2.0	18.5	93.7	114.0	14.5	
QVC19V304S QVVC19V304S	3 1/4 in.																			
QVC19V080S QVVC19V080S	80 mm																			
QVC19V085S QVVC19V085S	85 mm																			
QVC19V307S QVVC19V307S	3 7/16 in.																			
QVC19V308S QVVC19V308S	3 1/2 in.																			
QVC19V090S QVVC19V090S	90 mm																			
QVC22V311S QVVC22V311S	3 11/16 in.																			22222
QVC22V312S QVVC22V312S	3 3/4 in.																			
QVC22V100S QVVC22V100S	100 mm																			
QVC22V315S QVVC22V315S	3 15/16 in.																			
QVC22V400S QVVC22V400S	4 in.																			
QVC26V110S ⁽⁴⁾ QVVC26V110S ⁽⁴⁾	110 mm	22226	86.4	88.4	174.8	260.4	298.5	149.4	342.9	260.4	25.4	20	134.6	48.3	13.2	43.7	147.8	178.3	32.7	
QVC26V407S ⁽⁴⁾ QVVC26V407S ⁽⁴⁾	4 7/16 in.																			
QVC26V408S ⁽⁴⁾ QVVC26V408S ⁽⁴⁾	4 1/2 in.																			
QVC26V115S ⁽⁴⁾ QVVC26V115S ⁽⁴⁾	115 mm																			

⁽¹⁾Bearing part numbers use QV to designate single-nut units (uses Rv and Sv dimensions) and QVV to designate double-nut units (uses Rvv and Sv dimensions).

⁽²⁾Single-nut (QV) part number shown. Double-nut (QVV) version available upon request.

⁽³⁾Pilot tolerance: +0/-0.05 mm (+0/-0.002 in.).

⁽⁴⁾Six-bolt round housing.

QVCW AND QVVCW PILOTED FLANGE CARTRIDGES – STRAIGHT BORE EQUIVALENT

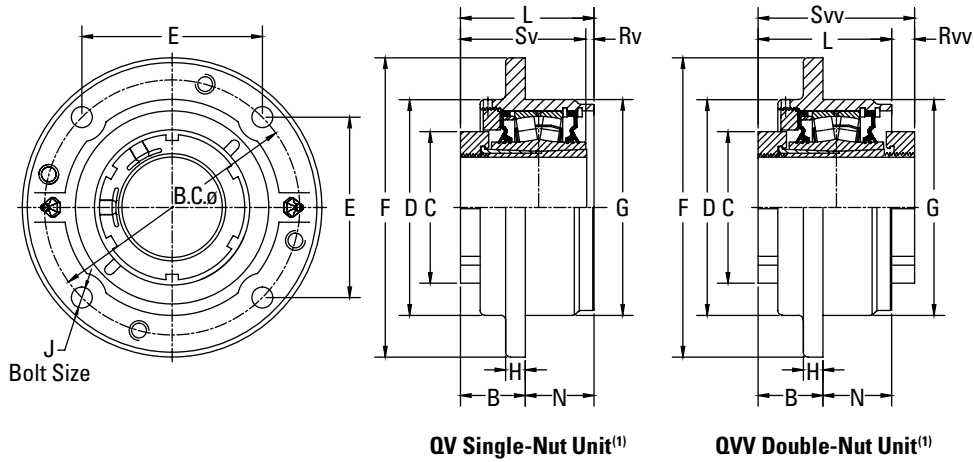

QV Single-Nut Unit⁽¹⁾

QVV Double-Nut Unit⁽¹⁾

Bearing Part No. ⁽¹⁾⁽²⁾	Shaft Dia.	Bearing No.	B FIX	B EXP	C	D	B.C.	E	F	G ⁽³⁾	H	J	L	N	Rv ⁽¹⁾	Rvv	Sv ⁽¹⁾	Svv	Wt.	
	mm in.		mm in.	mm in.	mm in.	mm in.	mm in.	mm in.	mm in.	mm in.	mm in.	mm in.	mm in.	mm in.	mm in.	mm in.	mm in.	mm in.	mm in.	kg lbs.
QVCW11V115S QVVCW11V115S	1 15/16 in.	22211	42.2	44.2	75.9	113.5	136.7	96.5	162.1	114.3	9.7	10	80.3	38.1	0.8	21.8	79.8	102.1	4.5	
QVCW11V200S QVVCW11V200S	2 in.		1.66	1.74	2.99	4.47	5.38	3.80	6.38	4.50	0.38	7/16	3.16	1.50	0.03	0.86	3.14	4.02	10	
QVCW11V050S QVVCW11V050S	50 mm																			
QVCW12V203S QVVCW12V203S	2 3/8 in.		43.2	45.5	80.3	126.7	152.4	107.7	181.1	127.0	14.2	12	84.6	41.4	4.8	17.5	79.8	102.1	5.9	
QVCW12V204S QVVCW12V204S	2 1/4 in.	22212	1.70	1.79	3.16	4.99	6.00	4.24	7.13	5.00	0.56	1/2	3.33	1.63	0.19	0.69	3.14	4.02	13	
QVCW12V055S QVVCW12V055S	55 mm																			
QVCW14V060S QVVCW14V060S	60 mm																			
QVCW14V207S QVVCW14V207S	2 7/16 in.		41.9	43.9	94.0	139.7	165.1	116.8	193.8	139.7	12.7	12	86.4	42.9	5.3	15.0	81.0	101.3	7.3	
QVCW14V208S QVVCW14V208S	2 1/2 in.	22214	1.65	1.73	3.70	5.50	6.50	4.60	7.63	5.50	0.50	1/2	3.40	1.69	0.21	0.59	3.19	3.99	16	
QVCW14V065S QVVCW14V065S	65 mm																			
QVCW16V211S QVVCW16V211S	2 11/16 in.																			
QVCW16V212S QVVCW16V212S	2 3/4 in.		37.6	39.6	106.4	162.1	190.5	134.6	222.3	161.9	12.7	16	85.1	47.8	1.8	18.5	83.6	103.6	10.0	
QVCW16V070S QVVCW16V070S	70 mm	22216																		
QVCW16V215S QVVCW16V215S	2 15/16 in.		1.48	1.56	4.19	6.38	7.50	5.30	8.75	6.36	0.50	3/8	3.35	1.88	0.07	0.73	3.29	4.08	22	
QVCW16V300S QVVCW16V300S	3 in.																			
QVCW16V075S QVVCW16V075S	75 mm																			

⁽¹⁾Bearing part numbers use QV to designate single-nut units (uses Rv and Sv dimensions) and QVV to designate double-nut units (uses Rvv and Sv dimensions).

⁽²⁾Single-nut (QV) part number shown. Double-nut (QVV) version available upon request.

⁽³⁾Pilot tolerance: +0/-0.05 mm (+0/-0.002 in.).

⁽⁴⁾Six-bolt round housing.

QVCW AND QVVCW PILOTED FLANGE CARTRIDGES – STRAIGHT BORE EQUIVALENT

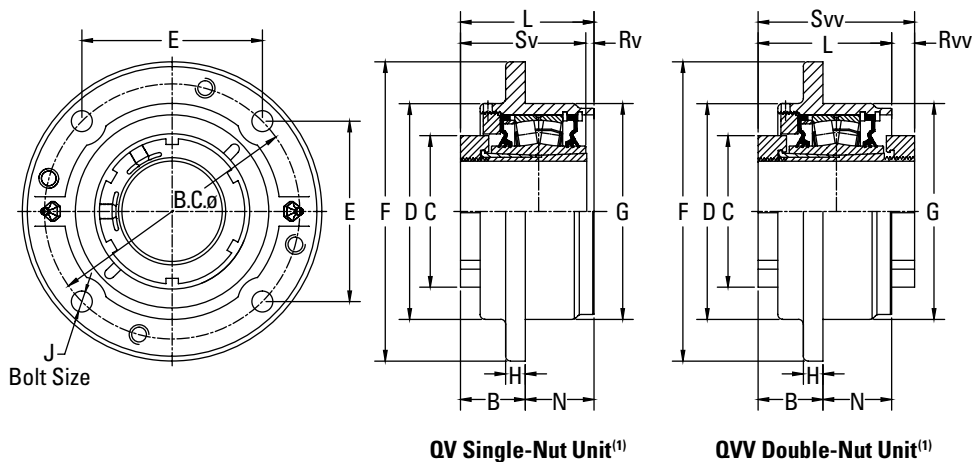

Bearing Part No. ⁽¹⁾⁽²⁾	Shaft Dia.	Bearing No.	B FIX	B EXP	C	D	B.C.	E	F	G ⁽³⁾	H	J	L	N	Rv ⁽¹⁾	Rvv	Sv ⁽¹⁾	Svv	Wt.																		
			mm in.	mm in.	mm in.	mm in.	mm in.	mm in.	mm in.	mm in.	mm in.	mm in.	mm in.	mm in.	mm in.	mm in.	mm in.	mm in.	mm in.	mm in.	kg lbs.																
QVCW19V303S QVVCW19V303S	3 3/16 in.	22219	49.8	51.8	124.5	199.1	219.2	154.9	260.4	187.3	22.4	20	97.5	47.8	3.8	16.8	93.7	114.0	14.5																		
QVCW19V304S QVVCW19V304S	3 1/4 in.																																				
QVCW19V080S QVVCW19V080S	80 mm																																				
QVCW19V085S QVVCW19V085S	85 mm																																				
QVCW19V307S QVVCW19V307S	3 7/16 in.																																				
QVCW19V308S QVVCW19V308S	3 1/2 in.																																				
QVCW19V090S QVVCW19V090S	90 mm																																				
QVCW22V311S QVVCW22V311S	3 1/16 in.																			22222	51.6	53.6	139.7	222.5	238.3	168.4	276.4	206.4	25.4	20	109.7	57.2	4.8	17.3	104.9	126.7	19.5
QVCW22V312S QVVCW22V312S	3 3/4 in.																																				
QVCW22V100S QVVCW22V100S	100 mm																																				
QVCW22V315S QVVCW22V315S	3 15/16 in.																																				
QVCW22V400S QVVCW22V400S	4 in.																																				
QVCW26V110S ⁽⁴⁾ QVVCW26V110S ⁽⁴⁾	110 mm	22226	72.4	74.4	174.8	260.4	298.5	149.4	342.9	260.4	25.4	20	140.5	68.3	7.4	37.8	147.8	178.3	32.7																		
QVCW26V407S ⁽⁴⁾ QVVCW26V407S ⁽⁴⁾	4 7/16 in.																																				
QVCW26V408S ⁽⁴⁾ QVVCW26V408S ⁽⁴⁾	4 1/2 in.																																				
QVCW26V115S ⁽⁴⁾ QVVCW26V115S ⁽⁴⁾	115 mm																																				
QVCW28V125S ⁽⁴⁾ QVVCW28V125S ⁽⁴⁾	125 mm																																				
QVCW28V415S ⁽⁴⁾ QVVCW28V415S ⁽⁴⁾	4 15/16 in.																			22228	66.5	68.6	190.0	266.7	323.9	162.1	374.7	279.4	26.2	24	144.5	78.0	3.3	33.8	147.8	178.3	46.3
QVCW28V500S ⁽⁴⁾ QVVCW28V500S ⁽⁴⁾	5 in.																																				
QVCW28V130S ⁽⁴⁾ QVVCW28V130S ⁽⁴⁾	130 mm																																				

⁽¹⁾Bearing part numbers use QV to designate single-nut units (uses Rv and Sv dimensions) and QVV to designate double-nut units (uses Rvv and Sv dimensions).

⁽²⁾Single-nut (QV) part number shown. Double-nut (QVV) version available upon request.

⁽³⁾Pilot tolerance: +0/-0.05 mm (+0/-0.002 in.).

⁽⁴⁾Six-bolt round housing.

QVMC AND QVVMC CARTRIDGE BLOCKS – TAPERED BORE EQUIVALENT

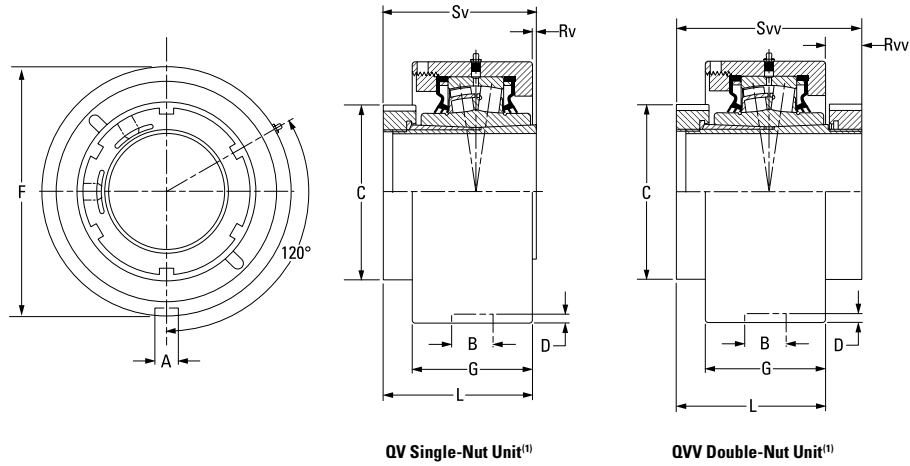

QV Single-Nut Unit⁽¹⁾

QVV Double-Nut Unit⁽¹⁾

Bearing Part No. ⁽¹⁾⁽²⁾	Shaft Dia.	Bearing No.	A	B	C	D	F	G	L FIX	L EXP	Rv ⁽¹⁾	Rvv	Sv ⁽¹⁾	Svv	Wt.
	mm in.		mm in.	mm in.	mm in.	mm in.	mm in.	mm in.	mm in.	mm in.	mm in.	mm in.	mm in.	mm in.	kg lbs.
QVMC11V115S QVVMC11V115S	1 1/8 in.	22211	13.5 0.530	23.0 0.91	75.9 2.99	4.8 0.19	115.09 (+0/-0.05) 4.53 (+0/-0.002)	55.4 2.18	79.0 3.11	81.0 3.19	0.8 0.03	23.1 0.91	79.8 3.14	102.1 4.02	4.5 10
QVMC11V200S QVVMC11V200S	2 in.														
QVMC11V050S QVVMC11V050S	50 mm														
QVMC13V203S QVVMC13V203S	2 3/8 in.														
QVMC13V204S QVVMC13V204S	2 1/4 in.	22213	13.5 0.530	23.0 0.91	80.3 3.16	4.8 0.19	127.00 (+0/-0.05) 5.00 (+0/-0.002)	67.1 2.64	85.9 3.38	87.9 3.46	0.5 0.02	21.8 0.86	85.3 3.36	107.7 4.24	5.4 12
QVMC13V055S QVVMC13V055S	55 mm														
QVMC15V060S QVVMC15V060S	60 mm														
QVMC15V207S QVVMC15V207S	2 7/8 in.														
QVMC15V208S QVVMC15V208S	2 1/2 in.	22215	15.1 0.594	26.2 1.03	94.0 3.70	6.4 0.25	149.23 (+0/-0.05) 5.86 (+0/-0.002)	70.6 2.78	87.4 3.44	89.4 3.52	5.1 0.20	16.5 0.65	82.6 3.25	103.9 4.09	8.2 18
QVMC15V065S QVVMC15V065S	65 mm														
QVMC17V211S QVVMC17V211S	2 11/16 in.														
QVMC17V212S QVVMC17V212S	2 3/4 in.														
QVMC17V070S QVVMC17V070S	70 mm	22217	15.1 0.594	27.5 1.08	106.4 4.19	7.1 0.28	171.45 (+0/-0.05) 6.75 (+0/-0.002)	74.9 2.95	91.2 3.59	93.2 3.67	6.4 0.25	15.0 0.59	84.6 3.33	106.2 4.18	11.8 26
QVMC17V215S QVVMC17V215S	2 15/16 in.														
QVMC17V300S QVVMC17V300S	3 in.														
QVMC17V075S QVVMC17V075S	75 mm														

⁽¹⁾Bearing part numbers use QV to designate single-nut units (uses Rv and Sv dimensions) and QVV to designate double-nut units (uses Rvv and Svv dimensions).

⁽²⁾Single-nut (QV) part number shown. Double-nut (QVV) version available upon request.

QVMC AND QVVMC CARTRIDGE BLOCKS – TAPERED BORE EQUIVALENT

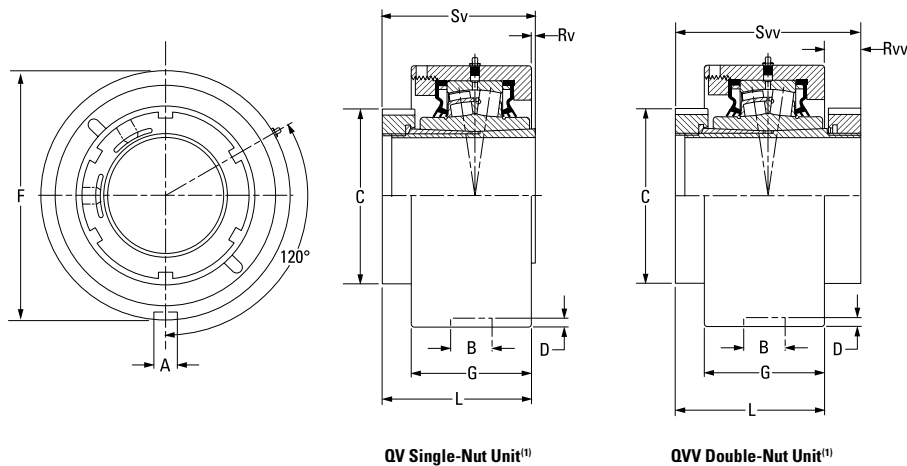

Bearing Part No. ⁽¹⁾⁽²⁾	Shaft Dia.	Bearing No.	A	B	C	D	F	G	L FIX	L EXP	Rv ⁽¹⁾	Rvv	Sv ⁽¹⁾	Svv	Wt.														
			mm in.	mm in.	mm in.	mm in.	mm in.	mm in.	mm in.	mm in.	mm in.	mm in.	mm in.	mm in.	mm in.	mm in.	kg lbs.												
QVMC20V303S QVVMC20V303S	3 3/16 in.	22220	19.8 0.781	32.5 1.28	124.5 4.90	8.0 0.31	206.38 (+0/-0.05) 8.13 (+0/-0.002)	85.6 3.37	102.1 4.02	104.1 4.10	6.9 0.27	15.2 0.60	95.3 3.75	117.3 4.62	14.5 32														
QVMC20V304S QVVMC20V304S	3 1/4 in.																												
QVMC20V080S QVVMC20V080S	80 mm																												
QVMC20V085S QVVMC20V085S	85 mm																												
QVMC20V307S QVVMC20V307S	3 7/16 in.																												
QVMC20V308S QVVMC20V308S	3 1/2 in.																												
QVMC20V090S QVVMC20V090S	90 mm																												
QVMC22V311S QVVMC22V311S	3 11/16 in.															22222	19.8 0.781	32.5 1.28	139.7 5.50	8.0 0.31	222.25 (+0/-0.08) 8.75 (+0/-0.003)	97.8 3.85	113.0 4.45	115.1 4.53	8.1 0.32	14.0 0.55	104.9 4.13	126.7 4.99	18.1 40
QVMC22V312S QVVMC22V312S	3 3/4 in.																												
QVMC22V100S QVVMC22V100S	100 mm																												
QVMC22V315S QVVMC22V315S	3 15/16 in.																												
QVMC22V400S QVVMC22V400S	4 in.	22226	19.8 0.780	38.1 1.50	174.8 6.88	8.0 0.31	265.10 (+0/-0.08) 10.44 (+0/-0.003)	104.4 4.11	141.5 5.57	143.5 5.65	6.4 0.25	36.8 1.45	147.8 5.82	178.3 7.02	23.6 52														
QVMC26V110S QVVMC26V110S	110 mm																												
QVMC26V407S QVVMC26V407S	4 7/16 in.																												
QVMC26V408S QVVMC26V408S	4 1/2 in.																												
QVMC26V115S QVVMC26V115S	115 mm																												

⁽¹⁾Bearing part numbers use QV to designate single-nut units (uses Rv and Sv dimensions) and QVV to designate double-nut units (uses Rvv and Sv dimensions).

⁽²⁾Single-nut (QV) part number shown. Double-nut (QVV) version available upon request.

QVVTU TAKE-UP BLOCKS – STRAIGHT BORE EQUIVALENT

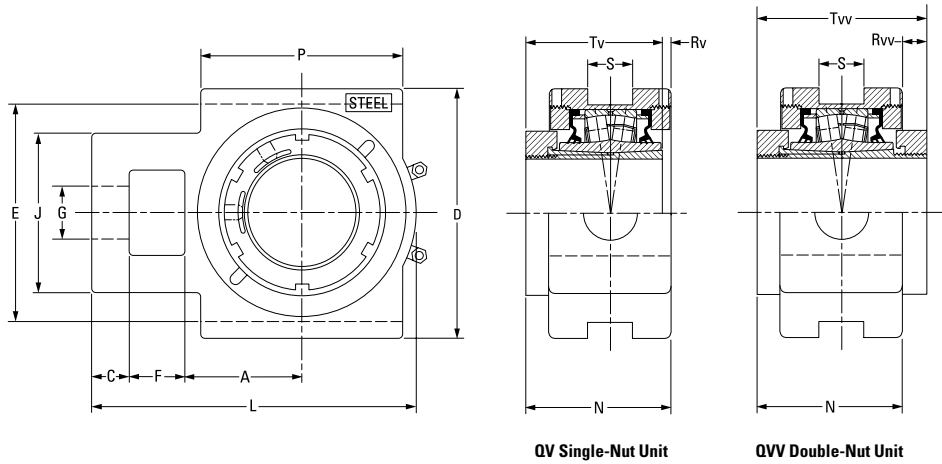

Bearing Part No. ⁽¹⁾	Shaft Dia.	Bearing No.	A	C	D	E	F	G	J	L	N	P	S	Rv ⁽¹⁾	Rv'	Tv ⁽¹⁾	Tv'	Wt.	
	mm in.		mm in.	mm in.	mm in.	mm in.	mm in.	mm in.	mm in.	mm in.	mm in.	mm in.	mm in.	mm in.	mm in.	mm in.	mm in.	kg lbs.	
QVVTU14V060S	60 mm	22214	69.9 2.75	22.4 0.88	149.4 5.88	130.3 5.13	33.3 1.31	35.1 1.38	95.3 3.75	193.8 7.63	88.4 3.48	120.7 4.75	26.9 1.06	3.3 0.13	15.5 0.61	85.1 3.35	103.9 4.09	7.7 17	
QVVTU14V207S	2 7/16 in.																		
QVVTU14V208S	2 1/2 in.																		
QVVTU14V065S	65 mm																		
QVVTU16V211S	2 1/16 in.	22216	76.2 3.00	25.4 1.00	171.5 6.75	150.9 5.94	39.6 1.56	39.6 1.56	108.0 4.25	219.7 8.65	90.2 3.55	120.7 4.75	46.0 1.81	2.3 0.09	16.3 0.64	87.6 3.45	106.2 4.18	15.9 35	
QVVTU16V212S	2 3/4 in.																		
QVVTU16V070S	70 mm																		
QVVTU16V215S	2 15/16 in.																		
QVVTU16V300S	3 in.	22219	92.2 3.63	25.4 1.00	193.8 7.63	173.0 6.81	46.0 1.81	49.3 1.94	124.0 4.88	257.0 10.12	99.6 3.92	158.8 6.25	46.0 1.81	0.5 0.02	18.0 0.71	99.1 3.90	117.6 4.63	20.0 44	
QVVTU16V075S	75 mm																		
QVVTU19V303S	3 3/16 in.																		
QVVTU19V304S	3 1/4 in.																		
QVVTU19V080S	80 mm	22222	104.9 4.13	28.7 1.13	239.8 9.44	219.2 8.63	54.1 2.13	50.8 2.00	143.0 5.63	296.9 11.69	111.3 4.21	177.8 7.00	52.3 2.06	1.5 0.32	18.8 0.55	110.0 4.13	130.3 4.99	26.3 58	
QVVTU19V085S	85 mm																		
QVVTU19V307S	3 7/16 in.																		
QVVTU19V308S	3 1/2 in.																		
QVVTU19V090S	90 mm																		
QVVTU22V311S	3 1/16 in.																		
QVVTU22V312S	3 3/4 in.																		
QVVTU22V100S	100 mm																		
QVVTU22V315S	3 15/16 in.																		
QVVTU22V400S	4 in.																		

⁽¹⁾Double-nut (QVV) part number shown. Single-nut (QV) version available upon request.

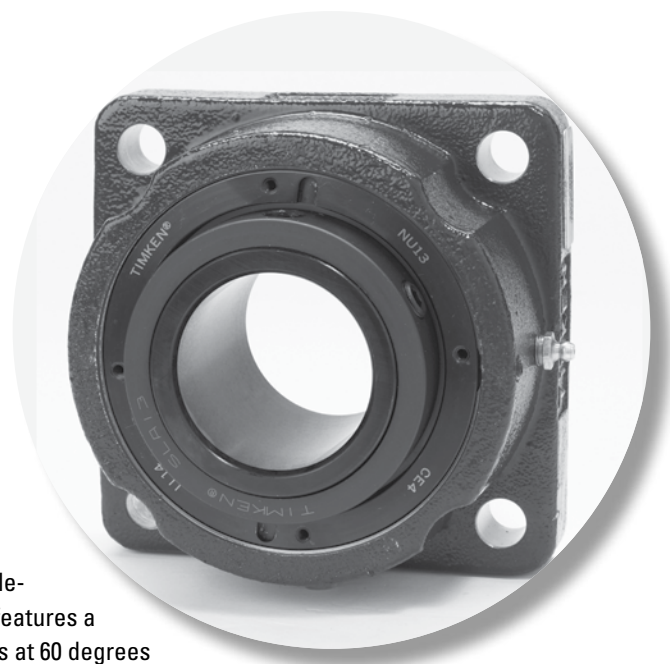

CL SERIES

Available in both single-collar (QA) and double-collar (QAA) versions, the CL bearing series features a concentric locking collar with two set screws at 60 degrees to provide maximum positive locking power with minimal run out.

The following topics are covered within this section:

Introduction	138
QAP and QAAP Two-Bolt Pillow Blocks	139
QAPL and QAAPL Two-Bolt Pillow Blocks	143
QAPMD and QAAPMD Two-Bolt Pillow Blocks	145
QASN and QAASN SN-Style Two-Bolt Pillow Blocks	147
QAAPXT 5000 Series Two-Bolt Pillow Blocks	149
QAPF and QAAPF Four-Bolt Pillow Blocks	150
QAPR and QAAPR Four-Bolt Pillow Blocks	152
QAAPX 5000 Series Four-Bolt Pillow Blocks	154
QAC and QAAC Piloted Flange Cartridges	155
QACMD and QAACMD Piloted Flange Cartridges	157
QACW and QAACW Piloted Flange Cartridges	159
QAF and QAAF Square Flange Blocks	161
QAFE and QAAFE Square Flange Blocks	163
QAFI and QAAFI Square Flange Blocks	165
QAFMD and QAAFMD Square Flange Blocks	167
QAAFX 5000 Series Flange Blocks	169
QAFY and QAAFY Round Flange Blocks	170
QAMC and QAAMC Cartridge Blocks	172
QATU and QAATU Take-Up Blocks	174
QATP and QAATP Top Angle Take-Up Blocks	176
QAMH and QAAMH Hanger Blocks	178

CL SERIES

Fig. 47. CL series single-collar (QA) insert available up to 100 mm (4 in.).



Fig. 48. CL series double-collar (QAA) insert for size ranges 50 mm – 130 mm (1 15/16 in. – 5 in.).

YOU HAVE CHOICES

For the CL series, you can select either single-collar or double-collar versions and choose from many seal configurations and housing styles, which are shown on page 15.

HOUSINGS

- Two-bolt pillow blocks
- Stainless steel two-bolt pillow blocks
- Four-bolt pillow blocks
- Flange blocks
- Stainless steel flange blocks
- Piloted flange cartridges
- Take-up blocks
- Cartridge blocks
- Hanger blocks

SEALS

- Labyrinth: DuPont™ Teflon® (T)
- Triple-lip: nitrile rubber (M), urethane (O) and Viton® (N)
- Double-lip: nitrile rubber (B) and Viton (C)
- Steel and urethane closed-end covers (CS)
- Steel and urethane open-end covers (CJ) with:
 - DuPont Teflon (T)
 - Triple-lip seal (DR)
 - V-ring seal (VR)
- Piloted flange cartridge backing plates (HSY) with:
 - Triple-lip seal (DR)
- Flange block backing plates (UFP)
 - V-ring (VR)

QAP AND QAAP TWO-BOLT PILLOW BLOCKS

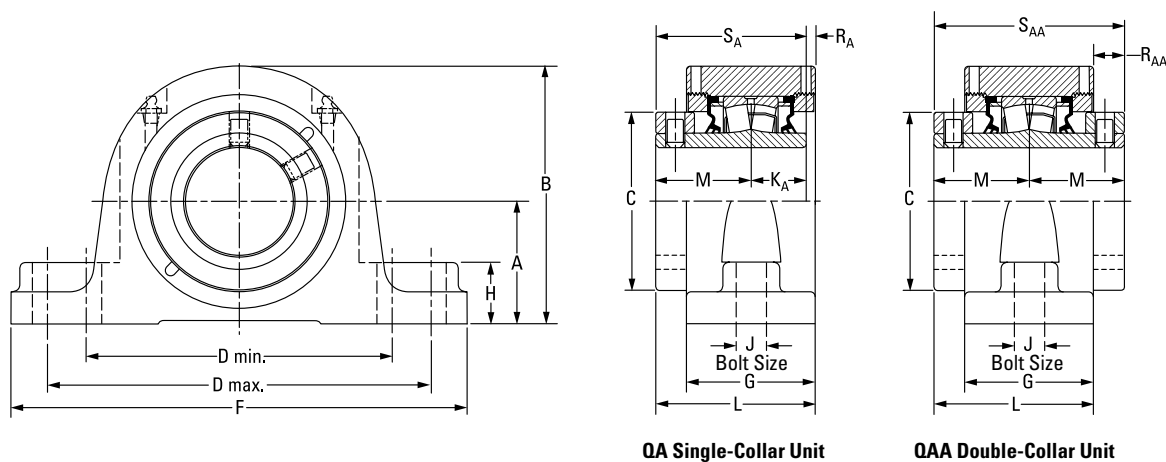

QA Single-Collar Unit

QAA Double-Collar Unit

Bearing Part No. ⁽¹⁾⁽²⁾	Shaft Dia.	Bearing No.	A	B	C	D min.	D max.	F	G	H	J	K _A	L	M	R _A	R _{AA}	S _A	S _{AA}	Wt.	
	mm in.		mm in.	mm in.	mm in.	mm in.	mm in.	mm in.	mm in.	mm in.	mm in.	mm in.	mm in.	mm in.	mm in.	mm in.	mm in.	mm in.	mm in.	kg lbs.
QAP08A035S	35 mm	22208	47.8	94.7	60.5	119.1	152.4	174.8	57.2	25.4	12	25.4	73.2	44.5	3.3	-	69.9	-	4.1	
QAP08A107S	1 7/16 in.		1.88	3.73	2.38	4.69	6.00	6.88	2.25	1.00	1/2	1.00	2.88	1.75	0.13	-	2.75	-	9	
QAP08A108S	1 1/2 in.	22208	54.1	101.1	60.5	119.1	165.1	200.2	57.2	25.4	12	25.4	73.2	44.5	3.3	-	69.9	-	4.1	
QAP09A111S	1 11/16 in.	22209	54.1	104.9	66.8	144.8	165.1	200.2	60.2	31.8	12	25.4	78.0	47.8	4.8	-	73.2	-	4.5	
QAP09A040S	40 mm	22209	57.2	108.0	66.8	158.8	180.8	225.6	62.0	31.8	16	25.4	78.7	47.8	5.6	-	73.2	-	4.5	
QAP09A112S	1 3/4 in.		2.25	4.25	2.63	6.25	7.12	8.88	2.44	1.25	5/8	1.00	3.10	1.88	0.22	-	2.88	-	10	
QAP09A045S	45 mm																			
QAP10A115S QAAP10A115S	1 15/16 in.	22210	57.2	122.2	73.2	152.4	181.1	225.6	62.0	31.8	16	25.4	79.0	47.5	6.1	17.0	72.9	95.3	5.9	
QAP10A200S QAAP10A200S	2 in.		2.25	4.81	2.88	6.00	7.13	8.88	2.44	1.25	5/8	1.00	3.11	1.87	0.24	0.67	2.87	3.75	13	
QAP10A050S QAAP10A050S	50 mm																			
QAP11A203S QAAP11A203S	2 3/16 in.	22211	63.5	133.4	82.6	165.1	200.2	244.6	66.8	31.8	16	28.7	84.3	50.8	4.8	17.5	79.5	101.6	7.7	
QAP11A204S QAAP11A204S	2 1/4 in.		2.50	5.25	3.25	6.50	7.88	9.63	2.63	1.25	5/8	1.13	3.32	2.00	0.19	0.69	3.13	4.00	17	
QAP11A055S QAAP11A055S	55 mm																			
QAP13A060S QAAP13A060S	60 mm	22213	69.9	147.3	96.8	174.8	219.2	260.4	73.7	35.1	16	31.5	91.4	54.6	5.3	17.8	86.1	109.2	10.0	
QAP13A207S QAAP13A207S	2 7/16 in.		2.75	5.80	3.81	6.88	8.63	10.25	2.90	1.38	5/8	1.24	3.60	2.15	0.21	0.70	3.39	4.30	22	
QAP13A208S QAAP13A208S	2 1/2 in.																			
QAP13A065S QAAP13A065S	65 mm																			

⁽¹⁾Bearing part numbers use QA to designate single-collar units (use S_A and R_A dimensions) and QAA to designate double-collar units (use S_{AA} and R_{AA} dimensions).

Continued on next page.

QAP AND QAAP TWO-BOLT PILLOW BLOCKS – continued

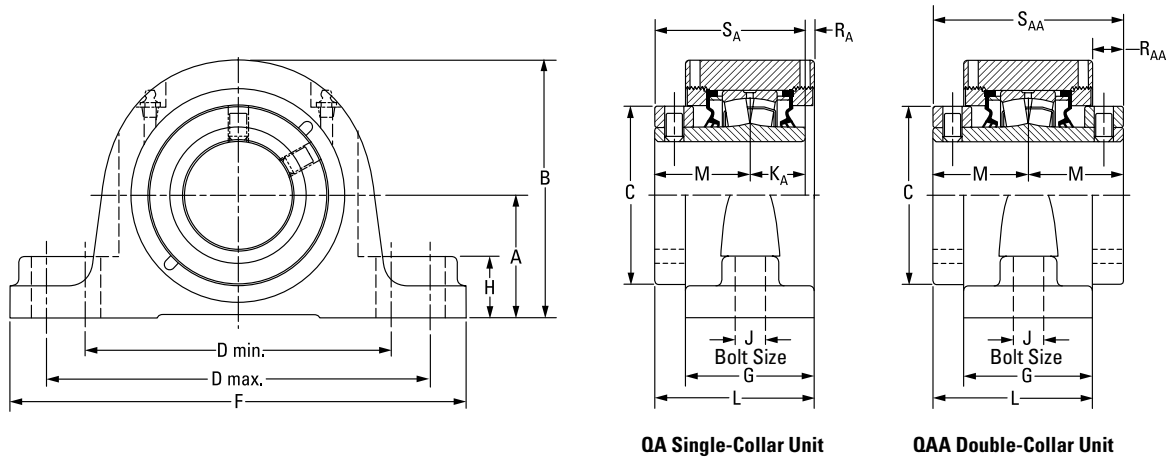

Continued from previous page.

Bearing Part No. ⁽¹⁾⁽²⁾	Shaft Dia.	Bearing No.	A	B	C	D min.	D max.	F	G	H	J	K _A	L	M	R _A	R _{AA}	S _A	S _{AA}	Wt.
			mm in.	mm in.	mm in.	mm in.	mm in.	mm in.	mm in.	mm in.	mm in.	mm in.	mm in.	mm in.	mm in.	mm in.	mm in.	mm in.	mm in.
QAP15A211S QAAP15A211S	2 11/16 in.	22215	79.5 3.13	164.3 6.47	109.0 4.29	200.2 7.88	244.6 9.63	295.4 11.63	76.2 3.00	35.1 1.38	20 3/4	31.8 1.25	98.3 3.87	60.2 2.37	6.4 0.25	22.1 0.87	91.9 3.62	120.4 4.74	12.7 28
QAP15A212S QAAP15A212S	2 3/4 in.																		
QAP15A070S QAAP15A070S	70 mm																		
QAP15A215S QAAP15A215S	2 15/16 in.																		
QAP15A300S QAAP15A300S	3 in.																		
QAP15A075S QAAP15A075S	75 mm																		
QAP18A303S QAAP18A303S	3 3/16 in.	22218	95.3 3.75	195.3 7.69	130.3 5.13	238.3 9.38	285.8 11.25	342.9 13.50	86.6 3.41	47.8 1.88	24 7/8	36.6 1.44	109.2 4.30	65.8 2.59	6.9 0.27	22.6 0.89	102.4 4.03	131.6 5.18	20.4 45
QAP18A304S QAAP18A304S	3 1/4 in.																		
QAP18A080S QAAP18A080S	80 mm																		
QAP18A085S QAAP18 A085S	85 mm																		
QAP18A307S QAAP18A307S	3 7/16 in.																		
QAP18A308S QAAP18A308S	3 1/2 in.																		
QAP18A090S QAAP18A090S	90 mm																		
QAP20A315S QAAP20A315S	3 15/16 in.	22220	104.9 4.13	209.8 8.26	152.4 6.00	255.0 10.04	320.0 12.60	362.0 14.25	94.7 3.73	50.8 2.00	24 1	41.4 1.63	122.9 4.84	75.4 2.97	6.1 0.24	28.2 1.11	116.8 4.60	150.9 5.94	26.8 59
QAP20A400S QAAP20A400S	4 in.																		
QAP20A100S QAAP20A100S	100 mm																		

⁽¹⁾Bearing part numbers use QA to designate single-collar units (use S_A and R_A dimensions) and QAA to designate double-collar units (use S_{AA} and R_{AA} dimensions).

QAP AND QAAP STAINLESS STEEL TWO-BOLT PILLOW BLOCKS

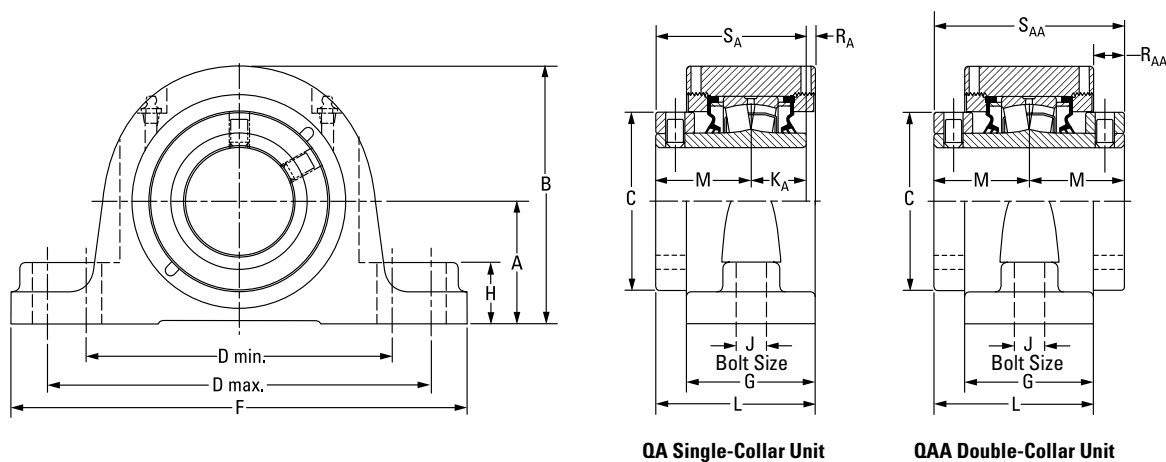

QA Single-Collar Unit

QAA Double-Collar Unit

Bearing Part No. ⁽¹⁾⁽²⁾	Shaft Dia.	Bearing No.	A	B	C	D min.	D max.	F	G	H	J	K _A	L	M	R _A	R _{AA}	S _A	S _{AA}	Wt.	
	mm in.		mm in.	mm in.	mm in.	mm in.	mm in.	mm in.	mm in.	mm in.	mm in.	mm in.	mm in.	mm in.	mm in.	mm in.	mm in.	mm in.	mm in.	kg lbs.
QAP08A035SOSS	35 mm	22208	47.8	94.7	60.5	119.1	152.4	174.8	57.2	25.4	12	25.4	73.2	44.5	3.3	-	69.9	-	4.1	
QAP08A107SOSS	1 7/16 in.		1.88	3.73	2.38	4.69	6.00	6.88	2.25	1.00	1/2	1.00	2.88	1.75	0.13	-	2.75	-	9	
QAP08A108SOSS	1 1/2 in.	22208	54.1	101.1	60.5	119.1	165.1	200.2	57.2	25.4	12	25.4	73.2	44.5	3.3	-	69.9	-	4.1	
			2.13	3.98	2.38	4.69	6.50	7.88	2.25	1.00	1/2	1.00	2.88	1.75	0.13	-	2.75	-	9	
QAP09A111SOSS	1 1/16 in.	22209	54.1	104.9	66.8	144.8	165.1	200.2	60.2	31.8	12	25.4	78.0	47.8	4.8	-	73.2	-	4.5	
			2.13	4.13	2.63	5.70	6.50	7.88	2.37	1.25	1/2	1.00	3.07	1.88	0.19	-	2.88	-	10	
QAP09A040SOSS	40 mm	22209	57.2	108.0	66.8	158.8	180.8	225.6	62.0	31.8	16	25.4	78.7	47.8	5.6	-	73.2	-	4.5	
QAP09A112SOSS	1 3/4 in.		2.25	4.25	2.63	6.25	7.12	8.88	2.44	1.25	5/8	1.00	3.10	1.88	0.22	-	2.88	-	10	
QAP09A045SOSS	45 mm	22210	57.2	122.2	73.2	152.4	181.1	225.6	62.0	31.8	16	25.4	79.0	47.5	6.1	17.0	72.9	95.3	5.9	
QAP10A115SOSS QAAP10A115SOSS	1 5/16 in.		2.25	4.81	2.88	6.00	7.13	8.88	2.44	1.25	5/8	1.00	3.11	1.87	0.24	0.67	2.87	3.75	13	
QAP10A050SOSS QAAP10A050SOSS	50 mm	22211	63.5	133.4	82.6	165.1	200.2	244.6	66.8	31.8	16	28.7	84.3	50.8	4.8	17.5	79.5	101.6	7.7	
QAP11A203SOSS QAAP11A203SOSS	2 3/16 in.		2.50	5.25	3.25	6.50	7.88	9.63	2.63	1.25	5/8	1.13	3.32	2.00	0.19	0.69	3.13	4.00	17	
QAP11A204SOSS QAAP11A204SOSS	2 1/4 in.	22211	63.5	133.4	82.6	165.1	200.2	244.6	66.8	31.8	16	28.7	84.3	50.8	4.8	17.5	79.5	101.6	7.7	
QAP11A055SOSS QAAP11A055SOSS	55 mm		2.50	5.25	3.25	6.50	7.88	9.63	2.63	1.25	5/8	1.13	3.32	2.00	0.19	0.69	3.13	4.00	17	
QAP13A060SOSS QAAP13A060SOSS	60 mm	22213	69.9	147.3	96.8	174.8	219.2	260.4	73.7	35.1	16	31.5	91.4	54.6	5.3	17.8	86.1	109.2	10.0	
QAP13A207SOSS QAAP13A207SOSS	2 7/16 in.		2.75	5.80	3.81	6.88	8.63	10.25	2.90	1.38	5/8	1.24	3.60	2.15	0.21	0.70	3.39	4.30	22	
QAP13A208SOSS QAAP13A208SOSS	2 1/2 in.	22213	69.9	147.3	96.8	174.8	219.2	260.4	73.7	35.1	16	31.5	91.4	54.6	5.3	17.8	86.1	109.2	10.0	
QAP13A065SOSS QAAP13A065SOSS	65 mm		2.75	5.80	3.81	6.88	8.63	10.25	2.90	1.38	5/8	1.24	3.60	2.15	0.21	0.70	3.39	4.30	22	

⁽¹⁾Bearing part numbers use QA to designate single-collar units (use S_A and R_A dimensions) and QAA to designate double-collar units (use S_{AA} and R_{AA} dimensions).

⁽²⁾Part number shown with 'O' seals – additional seals available upon request.

Continued on next page.

QAP AND QAAP STAINLESS STEEL TWO-BOLT PILLOW BLOCKS – continued

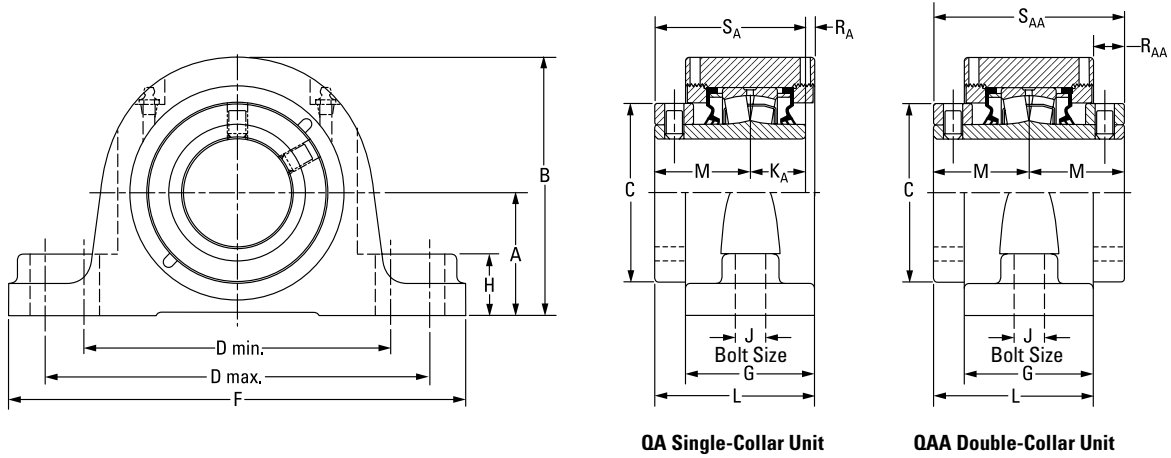

Continued from previous page.

Bearing Part No. ⁽¹⁾⁽²⁾	Shaft Dia.	Bearing No.	A	B	C	D min.	D max.	F	G	H	J	KA	L	M	RA	RAA	SA	SAA	Wt.
			mm in.	mm in.	mm in.	mm in.	mm in.	mm in.	mm in.	mm in.	mm in.	mm in.	mm in.	mm in.	mm in.	mm in.	mm in.	mm in.	mm in.
QAP15A211SOSS QAAP15A211SOSS	2 1/16 in.	22215	79.5 3.13	164.3 6.47	109.0 4.29	200.2 7.88	244.6 9.63	295.4 11.63	76.2 3.00	35.1 1.38	20 3/4	31.8 1.25	98.3 3.87	60.2 2.37	6.4 0.25	22.1 0.87	91.9 3.62	120.4 4.74	12.7 28
QAP15A212SOSS QAAP15A212SOSS	2 3/4 in.																		
QAP15A070SOSS QAAP15A070SOSS	70 mm																		
QAP15A215SOSS QAAP15A215SOSS	2 15/16 in.																		
QAP15A300SOSS QAAP15A300SOSS	3 in.																		
QAP15A075SOSS QAAP15A075SOSS	75 mm																		
QAP18A303SOSS QAAP18A303SOSS	3 3/16 in.	22218	95.3 3.75	195.3 7.69	130.3 5.13	238.3 9.38	285.8 11.25	342.9 13.50	86.6 3.41	47.8 1.88	24 7/8	36.6 1.44	109.2 4.30	65.8 2.59	6.9 0.27	22.6 0.89	102.4 4.03	131.6 5.18	20.4 45
QAP18A304SOSS QAAP18A304SOSS	3 1/4 in.																		
QAP18A080SOSS QAAP18A080SOSS	80 mm																		
QAP18A085SOSS QAAP18A085SOSS	85 mm																		
QAP18A307SOSS QAAP18A307SOSS	3 7/16 in.																		
QAP18A308SOSS QAAP18A308SOSS	3 1/2 in.																		
QAP18A090SOSS QAAP18A090SOSS	90 mm	22220	104.9 4.13	209.8 8.26	152.4 6.00	255.0 10.04	320.0 12.60	362.0 14.25	94.7 3.73	50.8 2.00	24 1	41.4 1.63	122.9 4.84	75.4 2.97	6.1 0.24	28.2 1.11	116.8 4.60	150.9 5.94	26.8 59
QAP20A315SOSS QAAP20A315SOSS	3 15/16 in.																		
QAP20A400SOSS QAAP20A400SOSS	4 in.																		
QAP20A100SOSS QAAP20A100SOSS	100 mm																		

⁽¹⁾Bearing part numbers use QA to designate single-collar units (use SA and RA dimensions) and QAA to designate double-collar units (use SAA and RAA dimensions).

⁽²⁾Part number shown with 'O' seals – additional seals available upon request.

QAPL AND QAAPL TWO-BOLT PILLOW BLOCKS

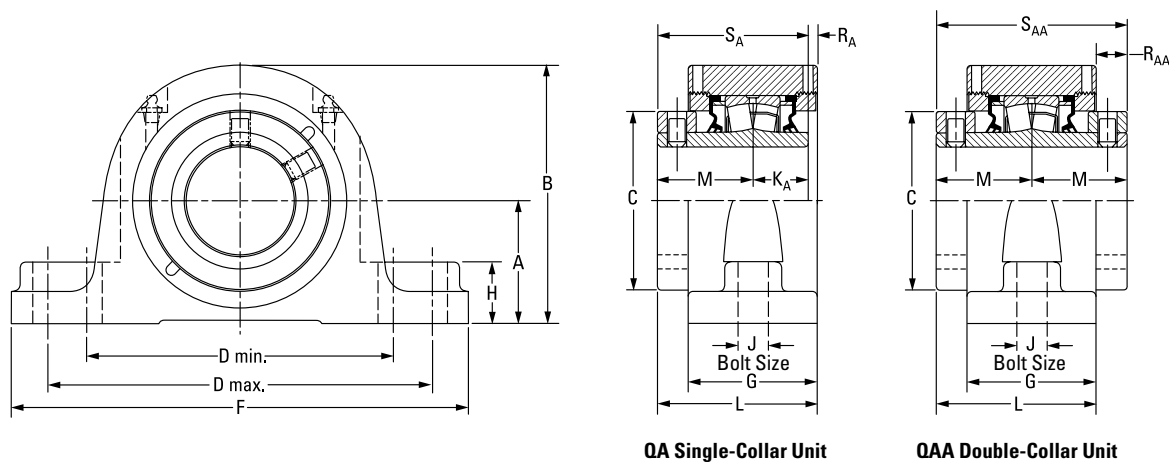

QA Single-Collar Unit

QAA Double-Collar Unit

Bearing Part No. ⁽¹⁾	Shaft Dia.	Bearing No.	A	B	C	D min.	D max.	F	G	H	J	K _A	L	M	R _A	R _{AA}	S _A	S _{AA}	Wt.	
			mm in.	mm in.	mm in.	mm in.	mm in.	mm in.	mm in.	mm in.	mm in.	mm in.	mm in.	mm in.	mm in.	mm in.	mm in.	mm in.	mm in.	mm in.
QAPL08A035S	35 mm	22208	47.8 1.88	94.7 3.73	60.5 2.38	119.1 4.69	152.4 6.00	174.8 6.88	57.2 2.25	25.4 1.00	12 ½	25.4 1.00	73.2 2.88	44.5 1.75	3.3 0.13	-	69.9 2.75	-	-	4.1 9
QAPL08A107S	1 7/8 in.																			
QAPL08A108S	1 ½ in.																			
QAPL09A040S	40 mm	22209	54.1 2.13	104.9 4.13	66.8 2.63	133.4 5.25	146.1 5.75	181.1 7.13	60.2 2.37	31.8 1.25	12 ½	25.4 1.00	78.0 3.07	47.8 1.88	4.8 0.19	-	73.2 2.88	-	-	4.5 10
QAPL09A111S	1 1/8 in.																			
QAPL09A112S	1 3/4 in.																			
QAPL09A045S	45 mm	22210	57.2 2.25	122.2 4.81	73.2 2.88	150.6 5.93	161.5 6.36	212.9 8.38	62.0 2.44	31.8 1.25	16 5/8	25.4 1.00	79.0 3.11	47.5 1.87	6.1 0.24	17.0 0.67	72.9 2.87	95.3 3.75	-	5.9 13
QAPL10A115S QAAPL10A115S	1 5/8 in.																			
QAPL10A200S QAAPL10A200S	2 in.																			
QAPL10A050S QAAPL10A050S	50 mm	22211	63.5 2.50	133.4 5.25	82.6 3.25	165.1 6.50	179.3 7.06	225.6 8.88	65.5 2.58	31.8 1.25	16 5/8	28.7 1.13	83.6 3.29	50.8 2.00	4.1 0.16	18.0 0.71	79.5 3.13	101.6 4.00	-	7.7 17
QAPL11A203S QAAPL11A203S	2 3/8 in.																			
QAPL11A204S QAAPL11A204S	2 1/4 in.																			
QAPL11A055S QAAPL11A055S	55 mm	22213	69.9 2.75	147.3 5.80	96.8 3.81	173.0 6.81	189.0 7.44	235.0 9.25	73.7 2.90	35.1 1.38	16 5/8	31.5 1.24	91.4 3.60	54.6 2.15	5.3 0.21	17.8 0.70	86.1 3.39	109.2 4.30	-	10.0 22
QAPL13A060S QAAPL13A060S	60 mm																			
QAPL13A207S QAAPL13A207S	2 7/8 in.																			
QAPL13A208S QAAPL13A208S	2 1/2 in.																			
QAPL13A065S QAAPL13A065S	65 mm																			

⁽¹⁾Bearing part numbers use QA to designate single-collar units (use S_A and R_A dimensions) and QAA to designate double-collar units (use S_{AA} and R_{AA} dimensions).

Continued on next page.

QAPL AND QAAPL TWO-BOLT PILLOW BLOCKS – continued

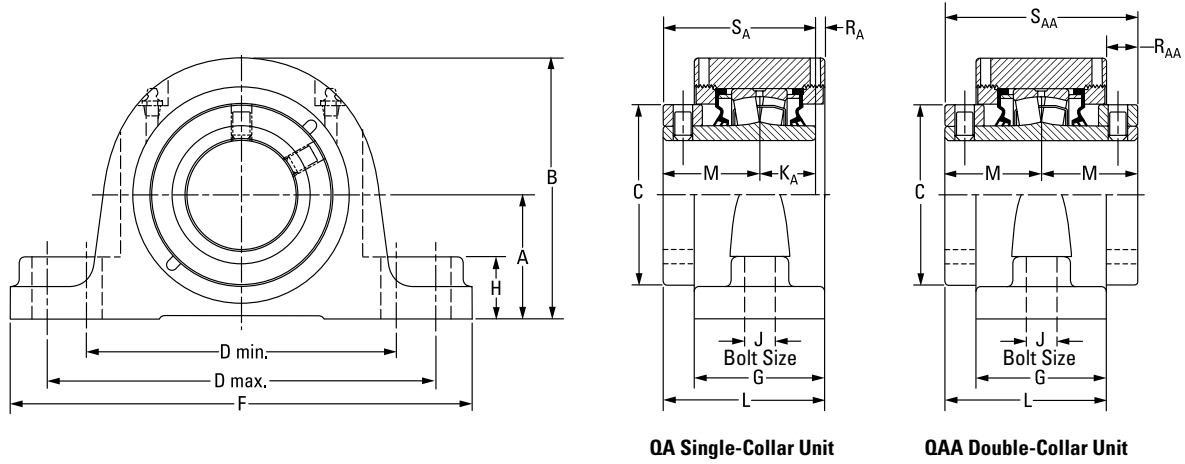

QA Single-Collar Unit

QAA Double-Collar Unit

Continued from previous page.

Bearing Part No. ⁽¹⁾	Shaft Dia.	Bearing No.	A	B	C	D min.	D max.	F	G	H	J	KA	L	M	RA	RAA	SA	SAA	Wt.	
	mm in.		mm in.	mm in.	mm in.	mm in.	mm in.	mm in.	mm in.	mm in.	mm in.	mm in.	mm in.	mm in.	mm in.	mm in.	mm in.	mm in.	mm in.	kg lbs.
QAPL15A211S QAAPL15A211S	2 1/16 in.	22215	82.6 3.25	167.4 6.59	109.0 4.29	195.6 7.70	213.4 8.40	265.2 10.44	76.2 3.00	35.1 1.38	20 3/4	31.8 1.25	98.3 3.87	60.2 2.37	6.4 0.25	22.1 0.87	91.9 3.62	120.4 4.74	12.7 28	
QAPL15A212S QAAPL15A212S	2 3/4 in.																			
QAPL15A070S QAAPL15A070S	70 mm																			
QAPL15A215S QAAPL15A215S	2 15/16 in.																			
QAPL15A300S QAAPL15A300S	3 in.																			
QAPL15A075S QAAPL15A075S	75 mm																			
QAPL18A303S QAAPL18A303S	3 3/16 in.	22218	95.3 3.75	195.3 7.69	130.3 5.13	235.0 9.25	273.1 10.75	330.2 13.00	86.6 3.41	47.8 1.88	24 7/8	36.6 1.44	109.2 4.30	65.8 2.59	6.9 0.27	22.6 0.89	102.4 4.03	131.6 5.18	20.4 45	
QAPL18A304S QAAPL18A304S	3 1/4 in.																			
QAPL18A080S QAAPL18A080S	80 mm																			
QAPL18A085S QAAPL18A085S	85 mm																			
QAPL18A307S QAAPL18A307S	3 7/16 in.																			
QAPL18A308S QAAPL18A308S	3 1/2 in.																			
QAPL18A090S QAAPL18A090S	90 mm	22220	108.0 4.25	212.9 8.38	152.4 6.00	255.0 10.04	320.0 12.60	362.0 14.25	94.7 3.73	54.1 2.13	24 1	41.4 1.63	122.9 4.84	75.4 2.97	6.1 0.24	28.2 1.11	116.8 4.60	150.9 5.94	26.8 59	
QAPL20A315S QAAPL20A315S	3 15/16 in.																			
QAPL20A400S QAAPL20A400S	4 in.																			
QAPL20A100S QAAPL20A100S	100 mm																			

⁽¹⁾Bearing part numbers use QA to designate single-collar units (use SA and RA dimensions) and QAA to designate double-collar units (use SAA and RAA dimensions).

QAPMD AND QAAPMD TWO-BOLT PILLOW BLOCKS

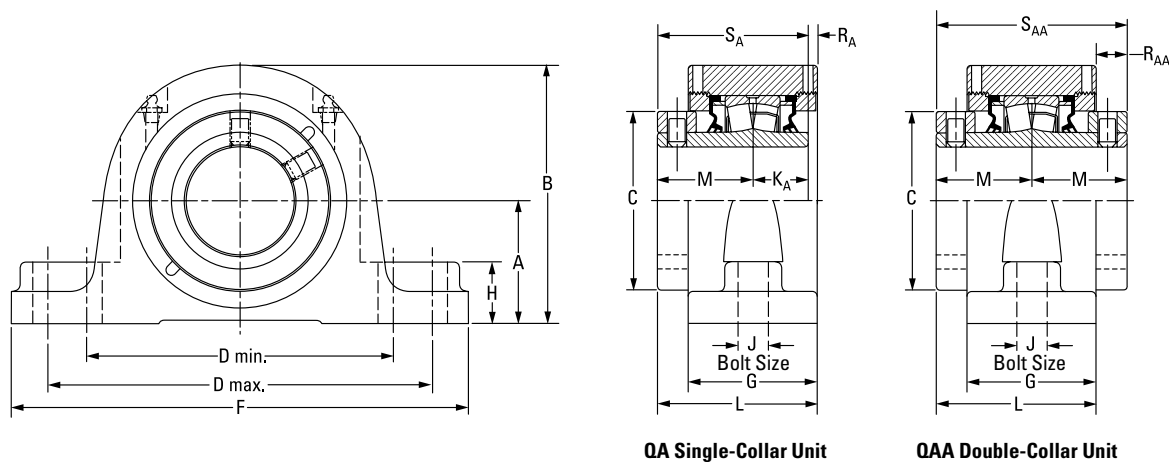

QA Single-Collar Unit

QAA Double-Collar Unit

Bearing Part No. ⁽¹⁾	Shaft Dia.	Bearing No.	A	B	C	D min.	D max.	F	G	H	J	K _A	L	M	R _A	R _{AA}	S _A	S _{AA}	Wt.	
	mm in.		mm in.	mm in.	mm in.	mm in.	mm in.	mm in.	mm in.	mm in.	mm in.	mm in.	mm in.	mm in.	mm in.	mm in.	mm in.	mm in.	mm in.	kg lbs.
QAPMD08A035S	35 mm	22208	54.1	110.5	60.5	131.6	149.4	184.2	57.2	25.4	12	25.4	73.2	44.5	3.3	-	69.9	-	4.1	
QAPMD08A107S	1 7/16 in.		2.13	4.35	2.38	5.18	5.88	7.25	2.25	1.00	1/2	1.00	2.88	1.75	0.13	-	2.75	-	9	
QAPMD08A108S	1 1/2 in.	22208	54.1	110.5	60.5	131.6	149.4	184.2	57.2	25.4	12	25.4	73.2	44.5	3.3	-	69.9	-	4.1	
QAPMD09A110S	1 5/8 in.	22209	54.1	113.3	66.8	139.7	157.2	189.0	62.0	25.4	12	25.4	78.7	47.8	5.6	-	73.2	-	4.5	
QAPMD09A040S	40 mm		2.13	4.46	2.63	5.5	6.19	7.44	2.44	1.00	1/2	1.00	3.10	1.88	0.22	-	2.88	-	10	
QAPMD09A111S	1 11/16 in.	22209	57.2	116.3	66.8	152.4	169.7	206.2	62.0	31.8	16	25.4	78.7	47.8	5.6	-	73.2	-	4.5	
QAPMD09A112S	1 3/4 in.		2.25	4.58	2.63	6.00	6.68	8.12	2.44	1.25	5/8	1.00	3.10	1.88	0.22	-	2.88	-	10	
QAPMD09A045S	45 mm																			
QAPMD10A115S QAAPMD10A115S	1 5/8 in.	22210	63.5	127.0	73.2	162.1	189.0	225.6	62.0	31.8	16	25.4	79.0	47.5	6.1	17.0	72.9	95.3	5.9	
QAPMD10A200S QAAPMD10A200S	2 in.		2.50	5.00	2.88	6.38	7.44	8.88	2.44	1.25	5/8	1.00	3.11	1.87	0.24	0.67	2.87	3.75	13	
QAPMD10A050S QAAPMD10A050S	50 mm	22211	69.9	139.7	82.6	174.8	201.7	241.3	66.8	38.1	16	28.7	84.3	50.8	4.8	17.5	79.5	101.6	7.7	
QAPMD11A203S QAAPMD11A203S	2 3/16 in.		2.75	5.50	3.25	6.88	7.94	9.50	2.63	1.50	5/8	1.13	3.32	2.00	0.19	0.69	3.13	4.00	17	
QAPMD11A204S QAAPMD11A204S	2 1/4 in.																			
QAPMD11A055S QAAPMD11A055S	55 mm	22213	76.2	153.7	96.5	190.5	223.0	273.1	73.7	34.9	20	31.5	91.4	54.6	5.3	17.8	86.1	109.2	10.0	
QAPMD13A060S QAAPMD13A060S	60 mm		3.00	6.05	3.80	7.50	8.78	10.75	2.90	1.38	3/4	1.24	3.60	2.15	0.21	0.70	3.39	4.30	22	
QAPMD13A207S QAAPMD13A207S	2 7/8 in.																			
QAPMD13A208S QAAPMD13A208S	2 1/2 in.																			
QAPMD13A065S QAAPMD13A065S	65 mm																			

⁽¹⁾Bearing part numbers use QA to designate single-collar units (use S_A and R_A dimensions) and QAA to designate double-collar units (use S_{AA} and R_{AA} dimensions).

Continued on next page.

QAPMD AND QAAPMD TWO-BOLT PILLOW BLOCKS – continued

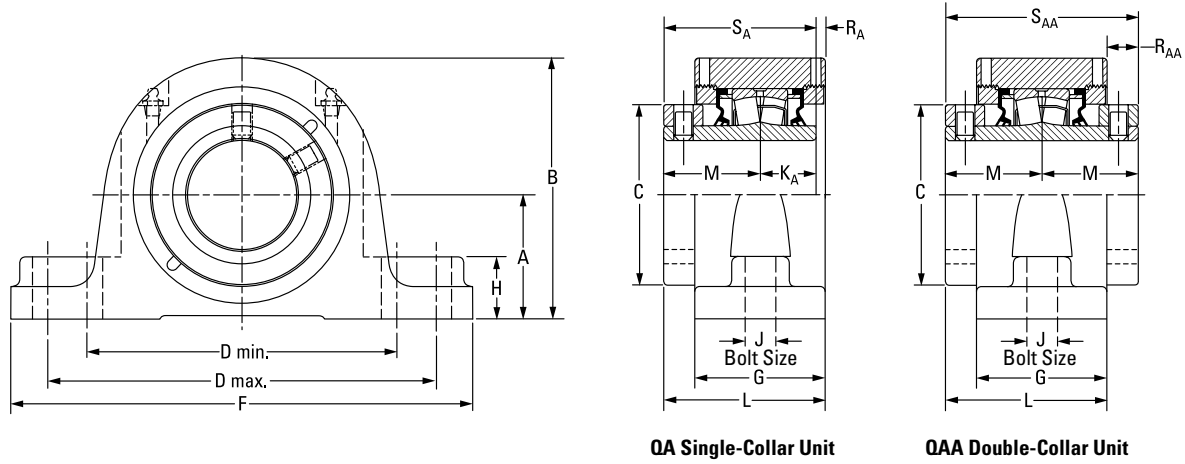

Continued from previous page.

Bearing Part No. ⁽¹⁾	Shaft Dia.	Bearing No.	A	B	C	D min.	D max.	F	G	H	J	KA	L	M	RA	RAA	SA	SAA	Wt.	
	mm in.		mm in.	mm in.	mm in.	mm in.	mm in.	mm in.	mm in.	mm in.	mm in.	mm in.	mm in.	mm in.	mm in.	mm in.	mm in.	mm in.	mm in.	kg lbs.
QAPL15A211S QAAPL15A211S	2 1/16 in.	22215	88.9 3.50	171.5 6.75	109.0 4.29	215.9 8.50	241.3 9.50	298.5 11.75	76.2 3.00	38.1 1.50	24 7/8	31.8 1.25	98.3 3.87	60.2 2.37	6.4 0.25	22.1 0.87	91.9 3.62	120.4 4.74	12.7 28	
QAPL15A212S QAAPL15A212S	2 3/4 in.																			
QAPL15A070S QAAPL15A070S	70 mm																			
QAPL15A215S QAAPL15A215S	2 15/16 in.																			
QAPL15A300S QAAPL15A300S	3 in.																			
QAPL15A075S QAAPL15A075S	75 mm																			
QAPL18A303S QAAPL18A303S	3 3/16 in.	22218	101.6 4.00	201.7 7.94	130.3 5.13	262.1 10.32	295.1 11.62	344.9 13.58	85.9 3.38	28.4 1.12	24 7/8	36.6 1.44	108.7 4.28	65.8 2.59	6.35 0.25	22.9 0.90	102.4 4.03	131.6 5.18	20.4 45	
QAPL18A304S QAAPL18A304S	3 1/4 in.																			
QAPL18A080S QAAPL18A080S	80 mm																			
QAPL18A085S QAAPL18A085S	85 mm																			
QAPL18A307S QAAPL18A307S	3 7/16 in.																			
QAPL18A308S QAAPL18A308S	3 1/2 in.																			
QAPL18A090S QAAPL18A090S	90 mm																			

QASN AND QAASN SN-STYLE TWO-BOLT PILLOW BLOCKS – PURE METRIC DESIGN

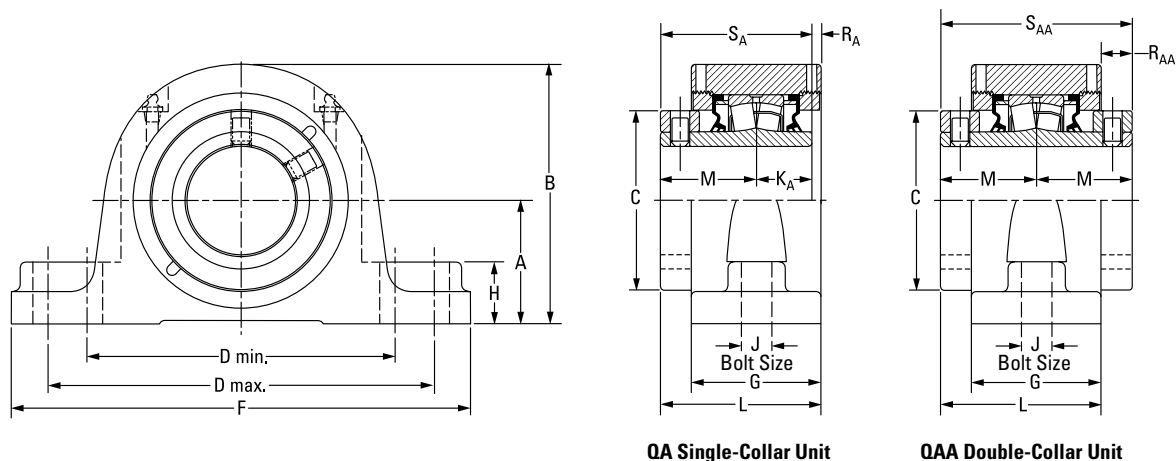

QA Single-Collar Unit

QAA Double-Collar Unit

Bearing Part No. ⁽¹⁾	Shaft Dia.	Bearing No.	A	B	C	D min.	D max.	F	G	H	J	K _A	L	M	R _A	R _{AA}	S _A	S _{AA}	Wt.	
	mm in.		mm in.	mm in.	mm in.	mm in.	mm in.	mm in.	mm in.	mm in.	mm in.	mm in.	mm in.	mm in.	mm in.	mm in.	mm in.	mm in.	mm in.	kg lbs.
QASN08A035S	35 mm	22208	60	111	60.5	159	175	205	62	35	12	25	75	44	5	–	70	–	10.5	
QASN08A107S	1 7/16 in.		2.36	4.37	2.38	6.26	6.89	8.07	2.44	1.38	1/2	1.00	2.95	1.75	0.20	–	2.75	–	23	
QASN08A108S	1 1/2 in.																			
QASN09A040S	40 mm	22209	60	111	66.8	159	175	205	62	35	12	25	79	48	6	–	73	–	10.5	
QASN09A111S	1 11/16 in.		2.36	4.37	2.63	6.26	6.89	8.07	2.44	1.38	1/2	1.00	3.10	1.88	0.22	–	2.88	–	23	
QASN09A112S	1 3/4 in.																			
QASN09A045S	45 mm	22210	70	136	73	183	216	254	68	25	16	25.4	82	48	9	14	73	95	12.7	
QASN10A115S	1 15/16 in.		2.76	5.35	2.87	7.20	8.50	10.00	2.68	0.98	5/8	1.00	3.23	1.87	0.35	0.55	2.87	3.75	28	
QAASN10A115S	1 1/2 in.																			
QASN10A200S	2 in.	22211	70	141	83	183	216	254	68	25	16	29	85	51	5	17	80	102	13.2	
QAASN10A200S	2 in.		2.76	5.55	3.27	7.20	8.50	10.00	2.68	0.98	5/8	1.14	3.35	2.01	0.20	0.67	3.15	4.02	29	
QASN10A050S	50 mm																			
QAASN10A050S	50 mm																			
QASN11A203S	2 3/16 in.	22213	80	157	96.8	196	235	275	74	35	16	31	92	55	6	18	86	110	15.9	
QAASN11A203S	2 3/16 in.		3.15	6.18	3.81	7.72	9.25	10.83	2.91	1.38	5/8	1.22	3.62	2.17	0.24	0.71	3.39	4.33	35	
QASN11A204S	2 1/4 in.																			
QAASN11A204S	2 1/4 in.																			
QASN11A055S	55 mm	22215	95	183	109.0	241	279	316	76	34	20	32	98	60	6	22	92	120	20.9	
QAASN11A055S	55 mm		3.74	7.20	4.29	9.49	10.98	12.44	2.99	1.34	3/4	1.26	3.86	2.36	0.24	0.87	3.62	4.72	46	
QASN15A211S	2 11/16 in.																			
QAASN15A211S	2 11/16 in.																			
QASN15A212S	2 3/4 in.																			
QAASN15A212S	2 3/4 in.																			
QASN15A070S	70 mm																			
QAASN15A070S	70 mm																			
QASN15A215S	2 15/16 in.																			
QAASN15A215S	2 15/16 in.																			
QASN15A300S	3 in.																			
QAASN15A300S	3 in.																			
QASN15A075S	75 mm																			
QAASN15A075S	75 mm																			

⁽¹⁾Bearing part numbers use QA to designate single-collar units (use S_A and R_A dimensions) and QAA to designate double-collar units (use S_{AA} and R_{AA} dimensions).

Continued on next page.

QASN AND QAASN SN-STYLE TWO-BOLT PILLOW BLOCKS – PURE METRIC DESIGN – continued

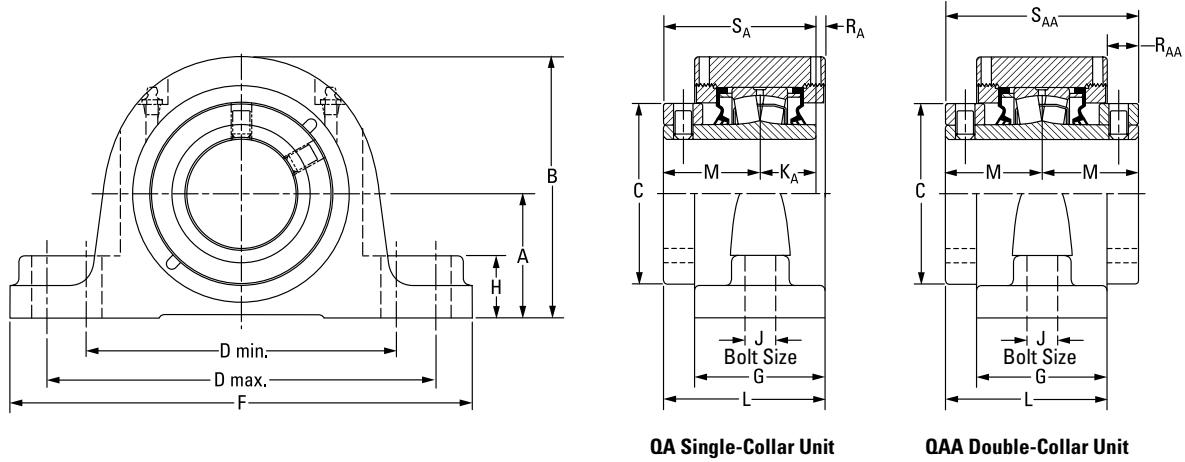

QA Single-Collar Unit

QAA Double-Collar Unit

Continued from previous page.

Bearing Part No. ⁽¹⁾	Shaft Dia.	Bearing No.	A	B	C	D min.	D max.	F	G	H	J	K _A	L	M	R _A	R _{AA}	S _A	S _{AA}	Wt.
			mm in.	mm in.	mm in.	mm in.	mm in.	mm in.	mm in.	mm in.	mm in.	mm in.	mm in.	mm in.	mm in.	mm in.	mm in.	mm in.	mm in.
QASN18A303S QAASN18A303S	3 3/16 in.	22218	100 3.94	200 7.87	130 5.12	279 10.98	292 11.50	345 13.58	86 3.39	39 1.54	20 3/4	37 1.46	109 4.29	66 2.60	6 0.24	23 0.91	102 4.02	132 5.20	25.5 56
QASN18A304S QAASN18A304S	3 1/4 in.																		
QASN18A080S QAASN18A080S	80 mm																		
QASN18A085S QAASN18A085S	85 mm	22218	112 4.41	212 8.35	130 5.12	279 10.98	292 11.50	345 13.58	86 3.39	39 1.54	20 3/4	37 1.46	109 4.29	66 2.60	6 0.24	23 0.91	102 4.02	132 5.20	25.5 56
QASN18A307S QAASN18A307S	3 7/16 in.	22218	112 4.41	212 8.35	130 5.12	290 11.42	327 12.87	380 14.96	86 3.39	39 1.54	24 7/8	37 1.46	109 4.29	66 2.60	6 0.24	23 0.91	102 4.02	132 5.20	25.5 56
QASN18A308S QAASN18A308S	3 1/2 in.																		
QASN18A090S QAASN18A090S	90 mm																		
QASN20A315S QAASN20A315S	3 15/16 in.	22220	125 4.92	241 9.49	152 5.98	319 12.56	366 14.41	410 16.14	101 3.98	50 1.97	24 7/8	41 1.61	126 4.96	75 2.95	10 0.39	25 0.98	117 4.61	150 5.91	35.9 79
QASN20A400S QAASN20A400S	4 in.																		
QASN20A100S QAASN20A100S	100 mm																		
QAASN22A110S	110 mm	22222	140 5.51	255 10.04	160 6.30	332 13.07	365 14.37	410 16.14	105 4.13	39 1.54	24 7/8	-	133 5.24	80 3.15	-	28 1.10	-	160 6.30	35.9 79
QAASN22A407S	4 7/16 in.	22222	150 5.91	265 10.43	160 6.30	367 14.45	400 15.75	445 17.52	105 4.13	49 1.93	24 7/8	-	133 5.24	80 3.15	-	28 1.10	-	160 6.30	40.0 88
QAASN22A408S	4 1/2 in.																		
QAASN22A115S	115 mm																		
QAASN26A125S	125 mm	22226	150 5.91	282 11.10	175 6.89	402 15.83	435 17.13	500 19.69	113 4.45	49 1.93	30 1 1/4	-	151 5.94	94 3.70	-	38 1.50	-	188 7.40	40.0 88
QAASN26A415S	4 15/16 in.																		
QAASN26A500S	5 in.																		
QAASN26A130S	130 mm																		

⁽¹⁾Bearing part numbers use QA to designate single-collar units (use S_A and R_A dimensions) and QAA to designate double-collar units (use S_{AA} and R_{AA} dimensions).

QAAPXT 5000 SERIES TWO-BOLT PILLOW BLOCKS

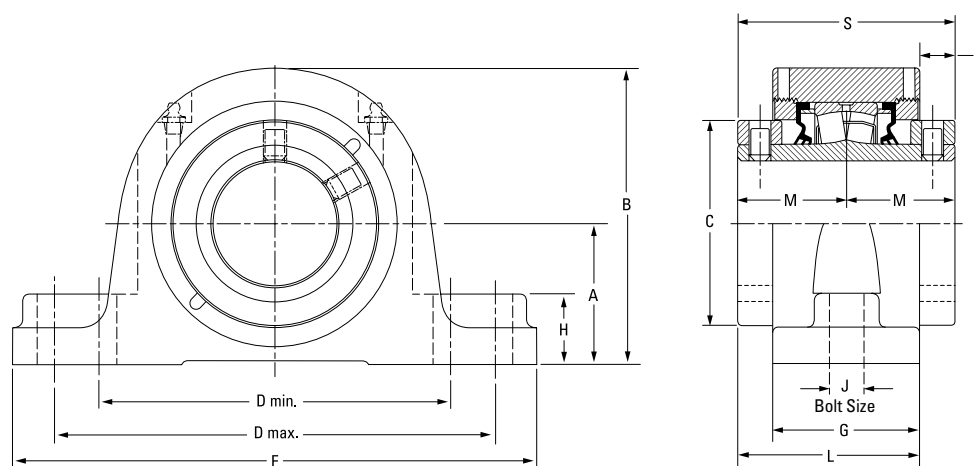

Bearing Part No.	Shaft Dia.	Bearing No.	A	B	C	D min.	D max.	F	G	H	J	L	M	R	S	Wt.
	mm in.		mm in.	mm in.	mm in.	mm in.	mm in.	mm in.	mm in.	mm in.	mm in.	mm in.	mm in.	mm in.	mm in.	kg lbs.
QAAPXT13A060S	60 mm	22213	76.2 3.00	153.7 6.05	96.8 3.81	194.6 7.66	223.0 8.78	285.8 11.25	73.7 2.90	35.1 1.38	20 3/4	91.4 3.60	54.6 2.15	17.8 0.70	109.2 4.30	10.0 22
QAAPXT13A207S	2 7/16 in.															
QAAPXT13A208S	2 1/2 in.															
QAAPXT13A065S	65 mm															
QAAPXT15A211S	2 11/16 in.	22215	88.9 3.50	173.7 6.84	109.0 4.29	230.1 9.06	265.2 10.44	330.2 13.00	75.7 2.98	35.1 1.38	24 7/8	98.0 3.86	60.2 2.37	22.4 0.88	120.4 4.74	12.7 28
QAAPXT15A212S	2 3/4 in.															
QAAPXT15A070S	70 mm															
QAAPXT15A215S	2 15/16 in.															
QAAPXT15A300S	3 in.															
QAAPXT15A075S	75 mm															

QAPF AND QAAPF FOUR-BOLT PILLOW BLOCKS

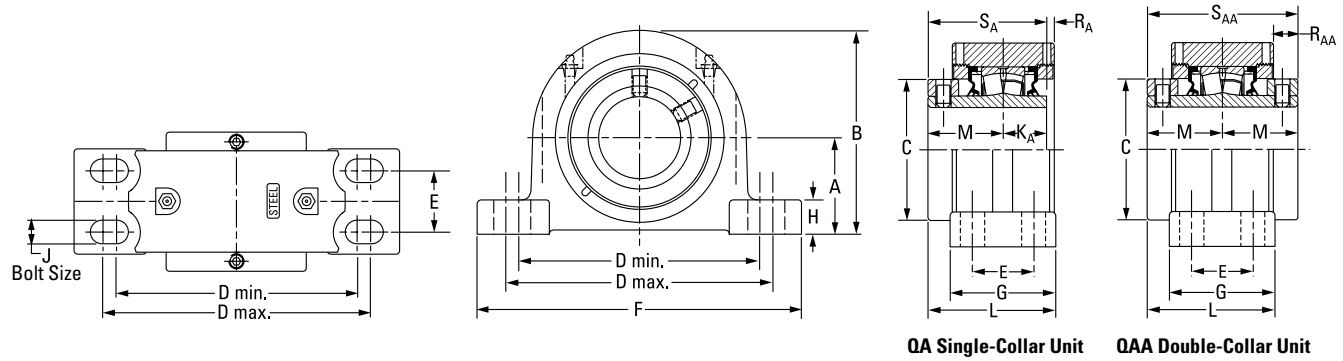

Bearing Part No. ⁽¹⁾	Shaft Dia.	Bearing No.	A	B	C	D min.	D max.	E	F	G	H	J	K _A	L	M	R _A	R _{AA}	S _A	S _{AA}	Wt.	
	mm in.		mm in.	mm in.	mm in.	mm in.	mm in.	mm in.	mm in.	mm in.	mm in.	mm in.	mm in.	mm in.	mm in.	mm in.	mm in.	mm in.	mm in.	mm in.	kg lbs.
QAPF13A060S QAAPF13A060S	60 mm	22213	69.9 2.75	147.3 5.80	96.8 3.81	174.8 6.88	193.8 7.63	44.5 1.75	235.0 9.25	76.2 3.00	24.9 0.98	16 5/8	31.5 1.24	92.7 3.65	54.6 2.15	5.3 0.21	17.8 0.70	86.1 3.39	109.2 4.30	9.1 20	
QAPF13A207S QAAPF13A207S	2 7/16 in.																				
QAPF13A208S QAAPF13A208S	2 1/2 in.																				
QAPF13A065S QAAPF13A065S	65 mm																				
QAPF15A211S QAAPF15A211S	2 13/16 in.	22215	82.6 3.25	167.6 6.60	109.0 4.29	193.0 7.60	231.1 9.10	47.8 1.88	265.2 10.44	79.5 3.13	32.8 1.29	16 5/8	31.8 1.25	100.1 3.94	60.2 2.37	6.1 0.24	22.4 0.88	91.9 3.62	120.4 4.74	12.2 27	
QAPF15A212S QAAPF15A212S	2 3/4 in.																				
QAPF15A070S QAAPF15A070S	70 mm																				
QAPF15A215S QAAPF15A215S	2 15/16 in.																				
QAPF15A300S QAAPF15A300S	3 in.	22218	95.3 3.75	195.3 7.69	130.3 5.13	225.6 8.88	276.4 10.88	50.8 2.00	312.4 12.30	95.3 3.75	39.6 1.56	20 3/4	36.6 1.44	113.5 4.47	65.8 2.59	7.9 0.31	21.3 0.84	102.4 4.03	131.6 5.18	22.2 49	
QAPF15A075S QAAPF15A075S	75 mm																				
QAPF18A303S QAAPF18A303S	3 3/16 in.																				
QAPF18A304S QAAPF18A304S	3 1/4 in.																				
QAPF18A080S QAAPF18A080S	80 mm	22218	95.3 3.75	195.3 7.69	130.3 5.13	225.6 8.88	276.4 10.88	50.8 2.00	312.4 12.30	95.3 3.75	39.6 1.56	20 3/4	36.6 1.44	113.5 4.47	65.8 2.59	7.9 0.31	21.3 0.84	102.4 4.03	131.6 5.18	22.2 49	
QAPF18A085S QAAPF18A085S	85 mm																				
QAPF18A307S QAAPF18A307S	3 7/16 in.																				
QAPF18A308S QAAPF18A308S	3 1/2 in.																				
QAPF18A090S QAAPF18A090S	90 mm																				

⁽¹⁾Bearing part numbers use QA to designate single-collar units (use S_A and R_A dimensions) and QAA to designate double-collar units (use S_{AA} and R_{AA} dimensions).

QAPF AND QAAPF FOUR-BOLT PILLOW BLOCKS

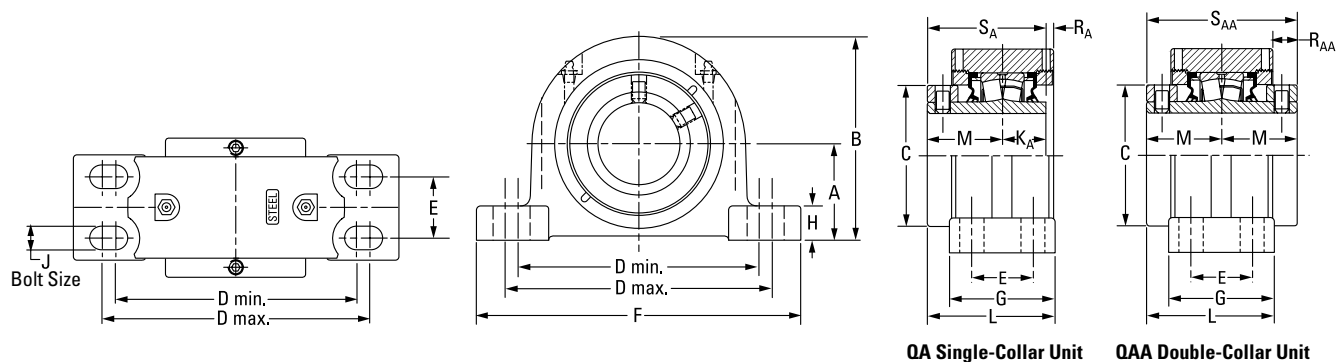

Bearing Part No. ⁽¹⁾	Shaft Dia.	Bearing No.	A	B	C	D min.	D max.	E	F	G	H	J	K _A	L	M	R _A	R _{AA}	S _A	S _{AA}	Wt.	
	mm in.		mm in.	mm in.	mm in.	mm in.	mm in.	mm in.	mm in.	mm in.	mm in.	mm in.	mm in.	mm in.	mm in.	mm in.	mm in.	mm in.	mm in.	mm in.	kg lbs.
QAPF20A315S QAAPF20A315S	3 15/16 in.	22220	108.0	223.0	152.4	276.4	339.9	57.2	378.0	109.5	35.6	20	41.4	130.3	75.4	8.9	25.1	116.6	150.9	30.4	
QAPF20A400S QAAPF20A400S	4 in.		4.25	8.78	6.00	10.88	13.38	2.25	14.88	4.31	1.40	3/4	1.63	5.13	2.97	0.35	0.99	4.59	5.94	67	
QAPF20A100S QAAPF20A100S	100 mm	22222	120.7	233.4	160.0	301.8	368.3	63.5	409.7	120.7	40.1	20	-	140.0	79.5	-	28.7	-	158.8	37.2	
QAAPF22A110S	110 mm		4.75	9.19	6.30	11.88	14.50	2.50	16.13	4.75	1.58	3/4	-	5.51	3.13	-	1.13	-	6.25	82	
QAAPF22A407S	4 7/16 in.	22226	139.7	279.7	175.0	349.3	403.4	69.9	444.5	128.0	39.1	24	-	158.5	94.5	-	36.8	-	189.0	60.8	
QAAPF22A408S	4 1/2 in.		5.50	11.01	6.89	13.75	15.88	2.75	17.50	5.04	1.54	7/8	-	6.24	3.72	-	1.45	-	7.44	134	
QAAPF22A115S	115 mm	22226	139.7	279.7	175.0	349.3	403.4	69.9	444.5	128.0	39.1	24	-	158.5	94.5	-	36.8	-	189.0	60.8	
QAAPF26A125S	125 mm		5.50	11.01	6.89	13.75	15.88	2.75	17.50	5.04	1.54	7/8	-	6.24	3.72	-	1.45	-	7.44	134	
QAAPF26A415S	4 15/16 in.		5.50	11.01	6.89	13.75	15.88	2.75	17.50	5.04	1.54	7/8	-	6.24	3.72	-	1.45	-	7.44	134	
QAAPF26A500S	5 in.																				
QAAPF26A130S	130 mm																				

⁽¹⁾Bearing part numbers use QA to designate single-collar units (use S_A and R_A dimensions) and QAA to designate double-collar units (use S_{AA} and R_{AA} dimensions).

QAPR AND QAAPR FOUR-BOLT PILLOW BLOCKS

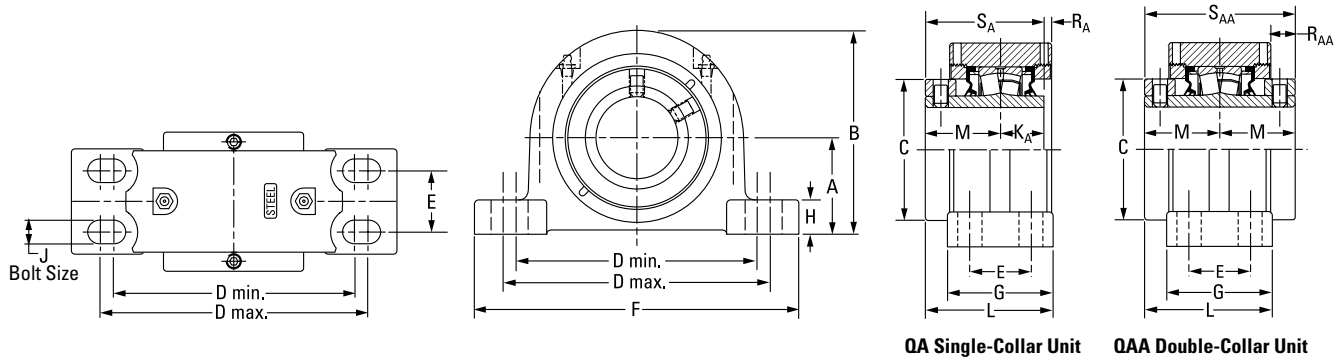

Bearing Part No. ⁽¹⁾	Shaft Dia.	Bearing No.	A	B	C	D min.	D max.	E	F	G	H	J	K _A	L	M	R _A	R _{AA}	S _A	S _{AA}	Wt.	
	mm in.		mm in.	mm in.	mm in.	mm in.	mm in.	mm in.	mm in.	mm in.	mm in.	mm in.	mm in.	mm in.	mm in.	mm in.	mm in.	mm in.	mm in.	mm in.	kg lbs.
QAPR13A060S QAAPR13A060S	60 mm	22213	69.9 2.75	147.3 5.80	96.8 3.81	181.1 7.13	222.3 8.75	47.8 1.88	260.4 10.25	82.6 3.25	24.9 0.98	16 5/8	31.5 1.24	95.8 3.77	54.6 2.15	5.3 0.21	17.8 0.70	86.1 3.39	109.2 4.30	9.1 20	
QAPR13A207S QAAPR13A207S	2 7/16 in.																				
QAPR13A208S QAAPR13A208S	2 1/2 in.																				
QAPR13A065S QAAPR13A065S	65 mm																				
QAPR15A211S QAAPR15A211S	2 11/16 in.	22215	79.5 3.13	164.3 6.47	109.0 4.29	203.2 8.00	243.8 9.60	54.1 2.13	275.1 10.83	85.9 3.38	29.5 1.16	16 5/8	31.8 1.25	102.1 4.02	60.2 2.37	6.1 0.24	22.4 0.88	91.9 3.62	120.4 4.74	12.2 27	
QAPR15A212S QAAPR15A212S	2 3/4 in.																				
QAPR15A070S QAAPR15A070S	70 mm																				
QAPR15A215S QAAPR15A215S	2 15/16 in.																				
QAPR15A300S QAAPR15A300S	3 in.	22218	95.3 3.75	195.3 7.69	130.3 5.13	235.0 9.25	285.8 11.25	60.5 2.38	346.2 13.63	95.3 3.75	39.6 1.56	20 3/4	36.6 1.44	113.5 4.47	65.8 2.59	7.9 0.31	21.3 0.84	102.4 4.03	131.6 5.18	22.2 49	
QAPR18A303S QAAPR18A303S	3 3/8 in.																				
QAPR18A304S QAAPR18A304S	3 1/4 in.																				
QAPR18A080S QAAPR18A080S	80 mm																				
QAPR18A085S QAAPR18A085S	85 mm																				
QAPR18A307S QAAPR18A307S	3 7/8 in.																				
QAPR18A308S QAAPR18A308S	3 1/2 in.																				
QAPR18A090S QAAPR18A090S	90 mm																				

⁽¹⁾Bearing part numbers use QA to designate single-collar units (use S_A and R_A dimensions) and QAA to designate double-collar units (use S_{AA} and R_{AA} dimensions).

QAPR AND QAAPR FOUR-BOLT PILLOW BLOCKS

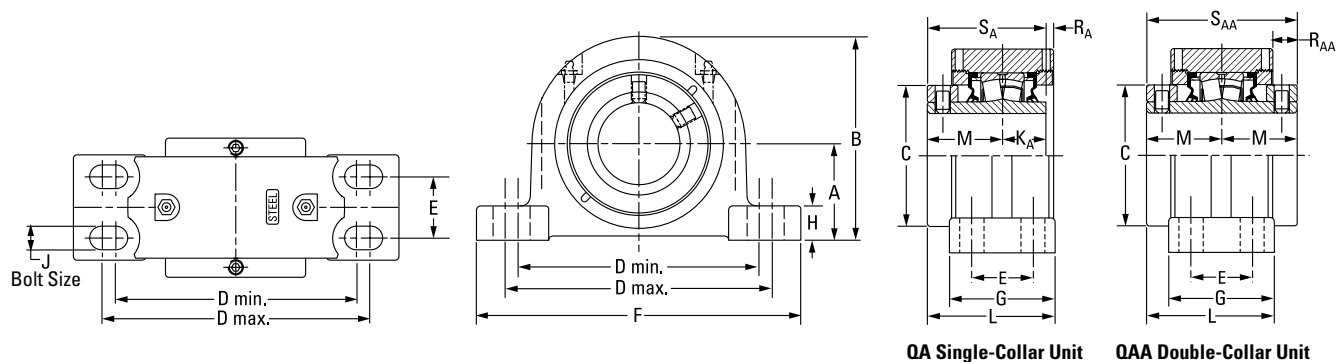

QA Single-Collar Unit QAA Double-Collar Unit

Bearing Part No. ⁽¹⁾	Shaft Dia.	Bearing No.	A	B	C	D min.	D max.	E	F	G	H	J	K _A	L	M	R _A	R _{AA}	S _A	S _{AA}	Wt.	
	mm in.		mm in.	mm in.	mm in.	mm in.	mm in.	mm in.	mm in.	mm in.	mm in.	mm in.	mm in.	mm in.	mm in.	mm in.	mm in.	mm in.	mm in.	mm in.	kg lbs.
QAPR20A311S QAAPR20A311S	3 1/16 in.	22220	108.0 4.25	223.0 8.78	152.4 6.00	276.4 10.88	339.9 13.38	57.2 2.25	378.0 14.88	109.5 4.31	35.6 1.40	20 3/4	41.4 1.63	130.3 5.13	75.4 2.97	9.1 0.36	25.1 0.99	116.7 4.59	150.9 5.94	30.4 67	
QAPR20A312S QAAPR20A312S	3 3/4 in.																				
QAPR20A315S QAAPR20A315S	3 15/16 in.																				
QAPR20A400S QAAPR20A400S	4 in.																				
QAPR20A100S QAAPR20A100S	100 mm																				
QAAPR22A110S	110 mm	22222	120.7 4.75	233.4 9.19	155.6 6.13	301.8 11.88	368.3 14.50	63.5 2.50	409.7 16.13	120.7 4.75	40.1 1.58	20 3/4	139.7 5.50	79.5 3.13	-	28.6 1.13	-	158.8 6.25	37.2 82		
QAAPR22A407S	4 7/16 in.																				
QAAPR22A408S	4 1/2 in.																				
QAAPR22A115S	115 mm																				
QAAPR26A125S	125 mm	22226	139.7 5.50	279.7 11.01	174.6 6.88	330.2 13.00	403.4 15.88	71.4 2.81	444.5 17.50	128.0 5.04	39.1 1.54	24 7/8	158.5 6.24	94.5 3.72	-	36.8 1.45	-	189.0 7.44	60.8 134		
QAAPR26A415S	4 15/16 in.																				
QAAPR26A500S	5 in.																				
QAAPR26A130S	130 mm																				

⁽¹⁾Bearing part numbers use QA to designate single-collar units (use S_A and R_A dimensions) and QAA to designate double-collar units (use S_{AA} and R_{AA} dimensions).

QAAPX 5000 SERIES FOUR-BOLT PILLOW BLOCKS

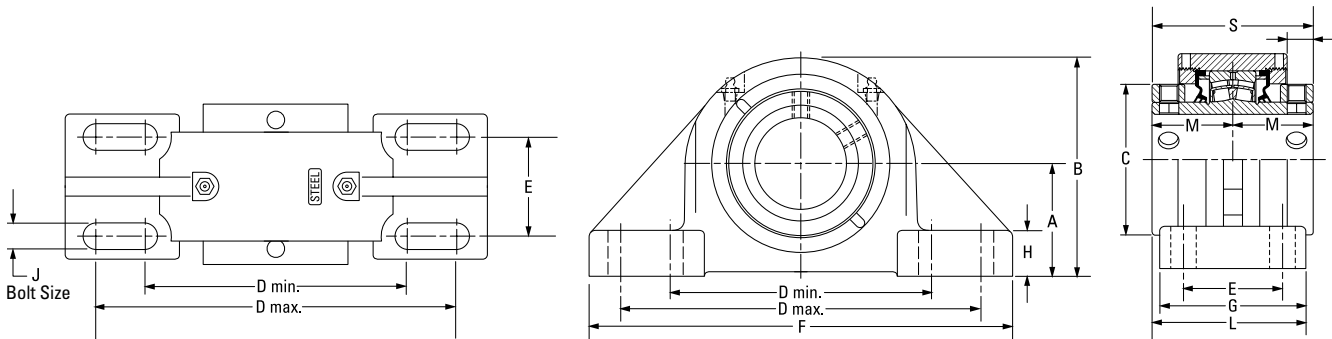

Bearing Part No. ⁽¹⁾	Shaft Dia.	Bearing No.	A	B	C	D min.	D max.	E	F	G	H	J	L	M	R	S	Wt.
	mm in.		mm in.	mm in.	mm in.	mm in.	mm in.	mm in.	mm in.	mm in.	mm in.	mm in.	mm in.	mm in.	mm in.	mm in.	kg lbs.
QAAPX13A060S	60 mm	22213	76.2 3.00	153.7 6.05	96.8 3.81	176.3 6.94	242.8 9.56	66.8 2.63	285.8 11.25	98.6 3.88	31.0 1.22	16 %	103.9 4.09	54.6 2.15	17.8 0.70	109.2 4.30	13.2 29
QAAPX13A207S	2 7/16 in.																
QAAPX13A208S	2 1/2 in.																
QAAPX13A065S	65 mm	22215	88.9 3.50	173.5 6.83	109.0 4.29	230.1 9.06	265.2 10.44	69.9 2.75	330.2 13.00	108.0 4.25	39.1 1.54	20 3/4	114.3 4.50	60.2 2.37	21.3 0.84	120.4 4.74	20.4 45
QAAPX15A211S	2 11/16 in.																
QAAPX15A212S	2 3/4 in.																
QAAPX15A070S	70 mm	22218	101.6 4.00	201.2 7.92	130.3 5.13	274.6 10.81	309.6 12.19	76.2 3.00	381.0 15.00	120.7 4.75	38.1 1.50	20 3/4	126.2 4.97	65.8 2.59	21.3 0.84	131.6 5.18	29.0 64
QAAPX15A075S	75 mm																
QAAPX18A303S	3 3/16 in.																
QAAPX18A304S	3 1/4 in.	22220	127.0 5.00	239.8 9.44	152.4 6.00	317.5 12.50	355.6 14.00	88.9 3.50	425.5 16.75	139.7 5.50	41.4 1.63	24 %	145.0 5.71	75.2 2.96	25.4 1.00	150.4 5.92	44.9 99
QAAPX18A080S	80 mm																
QAAPX18A085S	85 mm																
QAAPX18A307S	3 7/16 in.	22222	146.1 5.75	273.8 10.78	159.8 6.29	354.1 13.94	395.2 15.56	101.6 4.00	469.9 18.50	158.8 6.25	45.7 1.80	24 1	158.8 6.25	79.5 3.13	28.7 1.13	158.8 6.25	63.0 139
QAAPX18A308S	3 1/2 in.																
QAAPX18A090S	90 mm																
QAAPX20A315S	3 15/16 in.	22226	155.7 6.13	283.2 11.15	174.8 6.88	387.4 15.25	425.5 16.75	108.0 4.25	514.4 20.25	171.5 6.75	50.8 2.00	24.0 1 1/8	180.3 7.10	94.5 3.72	37.3 1.47	189.0 7.44	67.6 149
QAAPX20A400S	4 in.																
QAAPX20A100S	100 mm																
QAAPX22A110S	110 mm	22226	155.7 6.13	283.2 11.15	174.8 6.88	387.4 15.25	425.5 16.75	108.0 4.25	514.4 20.25	171.5 6.75	50.8 2.00	24.0 1 1/8	180.3 7.10	94.5 3.72	37.3 1.47	189.0 7.44	67.6 149
QAAPX22A407S	4 7/16 in.																
QAAPX22A408S	4 1/2 in.																
QAAPX22A115S	115 mm	22226	155.7 6.13	283.2 11.15	174.8 6.88	387.4 15.25	425.5 16.75	108.0 4.25	514.4 20.25	171.5 6.75	50.8 2.00	24.0 1 1/8	180.3 7.10	94.5 3.72	37.3 1.47	189.0 7.44	67.6 149
QAAPX26A125S	125 mm																
QAAPX26A415S	4 15/16 in.																
QAAPX26A500S	5 in.	22226	155.7 6.13	283.2 11.15	174.8 6.88	387.4 15.25	425.5 16.75	108.0 4.25	514.4 20.25	171.5 6.75	50.8 2.00	24.0 1 1/8	180.3 7.10	94.5 3.72	37.3 1.47	189.0 7.44	67.6 149
QAAPX26A130S	130 mm																

⁽¹⁾Bearing part numbers use QA to designate single-collar units (use S_A and R_A dimensions) and QAA to designate double-collar units (use S_{AA} and R_{AA} dimensions).

QAC AND QAAC PILOTED FLANGE CARTRIDGES

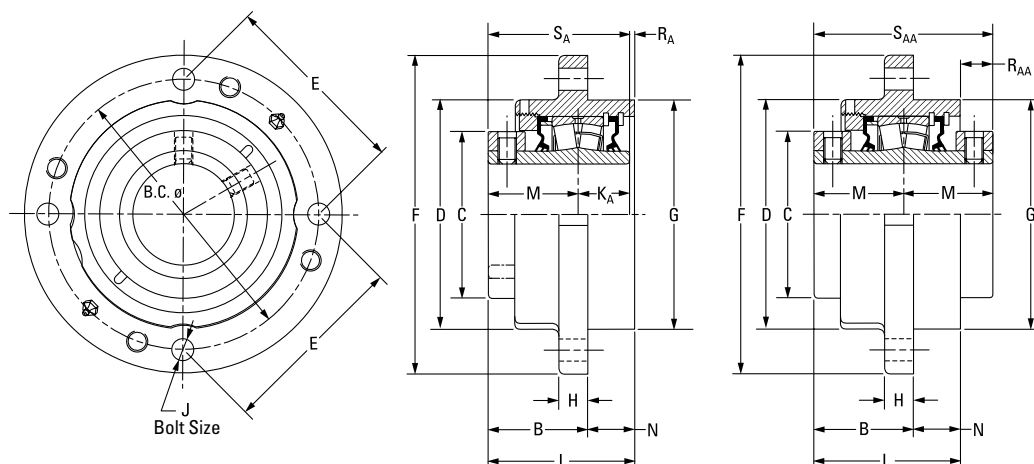

Bearing Part No. ⁽¹⁾	Shaft Dia.	Bearing No.	B	B	B.C.	C	D	E	F	G ⁽²⁾	H	J	K _A	L	L	M	N	R _A	R _{AA}	S _A	S _{AA}	Wt.
			FIX	EXP	mm	mm	mm	mm	mm	mm	mm	mm	mm	mm	mm	mm	mm	mm	mm	mm	mm	mm
QAC08A035S	35 mm	22208	49.8	51.8	111.3	60.5	92.2	78.5	133.4	92.1	12.7	10	25.4	73.7	75.7	44.5	23.9	3.8	–	69.9	–	3.6
QAC08A107S	1 7/16 in.		1.96	2.04	4.38	2.38	3.63	3.09	5.25	3.625	0.50	7/16	1.00	2.90	2.98	1.75	0.94	0.15	–	2.75	–	8
QAC08A108S	1 1/2 in.																					
QAC09A040S	40 mm	22209	54.6	56.6	130.3	66.8	111.3	91.9	155.7	108.0	12.7	10	25.4	77.0	78.2	47.8	22.4	3.8	–	73.2	–	4.1
QAC09A111S	1 11/16 in.		2.15	2.23	5.13	2.63	4.38	3.62	6.13	4.250	0.50	7/16	1.00	3.03	3.08	1.88	0.88	0.15	–	2.88	–	9
QAC09A112S	1 3/4 in.																					
QAC09A045S	45 mm	22210	50.5	52.6	136.7	73.2	113.5	96.5	162.1	114.3	16.0	10	25.4	77.5	79.5	47.5	26.9	4.6	18.5	72.9	95.3	4.5
QAC10A115S QAAC10A115S	1 15/16 in.		1.99	2.07	5.38	2.88	4.47	3.80	6.38	4.500	0.63	7/16	1.00	3.05	3.13	1.87	1.06	0.18	0.73	2.87	3.75	10
QAC10A200S QAAC10A200S	2 in.																					
QAC10A050S QAAC10A050S	50 mm	22211	54.4	56.4	152.4	82.6	127.0	107.7	185.4	127.0	14.7	12	28.7	83.1	85.1	50.8	28.7	3.6	18.5	79.5	101.6	5.9
QAC11A203S QAAC11A203S	2 3/16 in.		2.14	2.22	6.00	3.25	5.00	4.24	7.30	5.000	0.58	1/2	1.13	3.27	3.35	2.00	1.13	0.14	0.73	3.13	4.00	13
QAC11A204S QAAC11A204S	2 1/4 in.																					
QAC11A055S QAAC11A055S	55 mm	22213	60.5	62.5	165.1	96.8	139.7	116.8	193.8	139.7	17.5	12	31.5	88.9	90.9	54.6	28.7	3.0	20.3	86.1	109.2	7.3
QAC13A060S QAAC13A060S	60 mm		2.38	2.46	6.50	3.81	5.50	4.60	7.63	5.500	0.69	1/2	1.24	3.50	3.58	2.15	1.13	0.12	0.80	3.39	4.30	16
QAC13A207S QAAC13A207S	2 7/16 in.																					
QAC13A208S QAAC13A208S	2 1/2 in.																					
QAC13A065S QAAC13A065S	65 mm																					

⁽¹⁾ Bearing part numbers use QA to designate single-collar units (use S_A and R_A dimensions) and QAA to designate double-collar units (use S_{AA} and R_{AA} dimensions).

⁽²⁾ Pilot tolerance: +0/-0.051 mm (+0/-0.002 in.).

⁽³⁾ Six-bolt housing.

Continued on next page.

QAC AND QAAC PILOTED FLANGE CARTRIDGES – continued

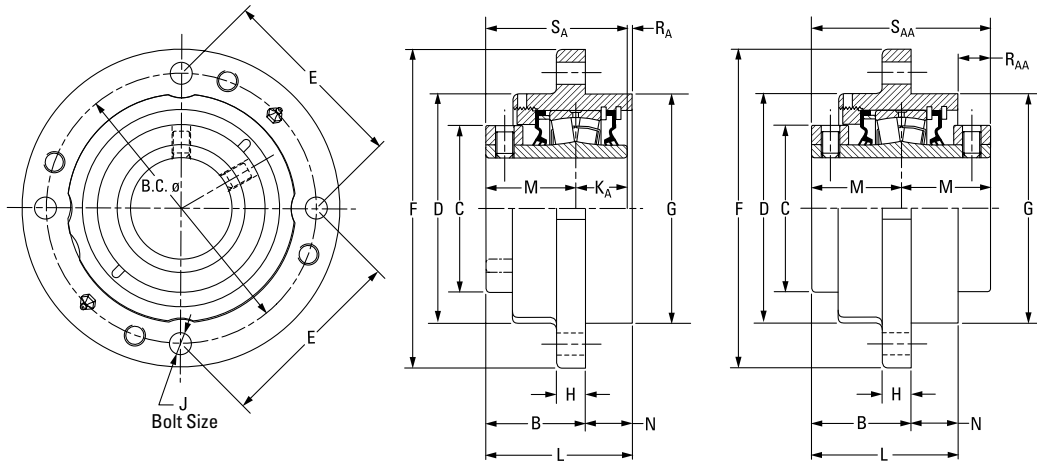

Continued from previous page.

Bearing Part No. ⁽¹⁾	Shaft Dia.	Bearing No.	B FIX	B EXP	B.C.	C	D	E	F	G ⁽²⁾	H	J	K _A	L FIX	L EXP	M	N	R _A	R _{AA}	S _A	S _{AA}	Wt.																						
	mm in.		mm in.	mm in.	mm in.	mm in.	mm in.	mm in.	mm in.	mm in.	mm in.	mm in.	mm in.	mm in.	mm in.	mm in.	mm in.	mm in.	mm in.	mm in.	mm in.	mm in.	kg lbs.																					
QAC15A211S QAAC15A211S	2 1/16 in.	22215	62.5 2.46	64.5 2.54	190.5 7.50	109.0 4.29	162.1 6.38	134.6 5.30	222.3 8.75	161.9 6.375	20.6 0.81	16 5/8	31.8 1.25	94.2 3.71	96.3 3.79	60.2 2.37	31.8 1.25	2.3 0.09	21.6 0.85	91.9 3.62	120.4 4.74	10.0 22																						
QAC15A212S QAAC15A212S	2 3/4 in.																																											
QAC15A070S QAAC15A070S	70 mm																																											
QAC15A215S QAAC15A215S	2 15/16 in.																																											
QAC15A300S QAAC15A300S	3 in.																																											
QAC15A075S QAAC15A075S	75 mm																																											
QAC18A303S QAAC18A303S	3 3/16 in.																						22218	73.2 2.88	75.2 2.96	219.2 8.63	130.3 5.13	187.5 7.38	154.9 6.10	262.6 10.34	187.3 7.375	25.4 1.00	20 3/4	36.6 1.44	106.4 4.19	108.5 4.27	65.8 2.59	33.3 1.31	4.1 0.16	25.1 0.99	102.4 4.03	131.6 5.18	14.5 32	
QAC18A304S QAAC18A304S	3 1/4 in.																																											
QAC18A080S QAAC18A080S	80 mm																																											
QAC18A085S QAAC18A085S	85 mm																																											
QAC18A307S QAAC18A307S	3 7/16 in.																																											
QAC18A308S QAAC18A308S	3 1/2 in.																																											
QAC18A090S QAAC18A090S	90 mm																																											
QAC20A315S QAAC20A315S	3 15/16 in.	22220	72.1 2.84	74.2 2.92	238.3 9.38	152.4 6.00	206.5 8.13	168.4 6.63	276.4 10.88	206.4 8.125	25.4 1.00	20 3/4	41.4 1.63	126.0 4.96	128.0 5.04	75.4 2.97	54.1 2.13	9.4 0.37	24.9 0.98	116.6 4.59	150.9 5.94	19.5 43																						
QAC20A400S QAAC20A400S	4 in.																																											
QAC20A100S QAAC20A100S	100 mm																																											
QAAC22A110S	110 mm																						22222	78.0 3.07	80.0 3.15	298.5 11.75 ⁽³⁾	160.0 6.30	254.0 10.00	149.4 5.88 ⁽³⁾	342.9 13.50	260.4 10.250	25.4 1.00	20 3/4 ⁽³⁾	126.2 4.97	128.3 5.05	79.5 3.13	48.3 1.90	-	32.8 1.29	-	158.8 6.25	32.7 72		
QAAC22A407S ⁽³⁾	4 7/16 in.																																											
QAAC22A408S ⁽³⁾	4 1/2 in.																																											
QAAC22A115S ⁽³⁾	115 mm																																											

⁽¹⁾Bearing part numbers use QA to designate single-collar units (use S_A and R_A dimensions) and QAA to designate double-collar units (use S_{AA} and R_{AA} dimensions).

⁽²⁾Pilot tolerance: +0/-0.051 mm (+0/-0.002 in.).

⁽³⁾Six-bolt housing.

QACMD AND QAACMD PILOTED FLANGE CARTRIDGES

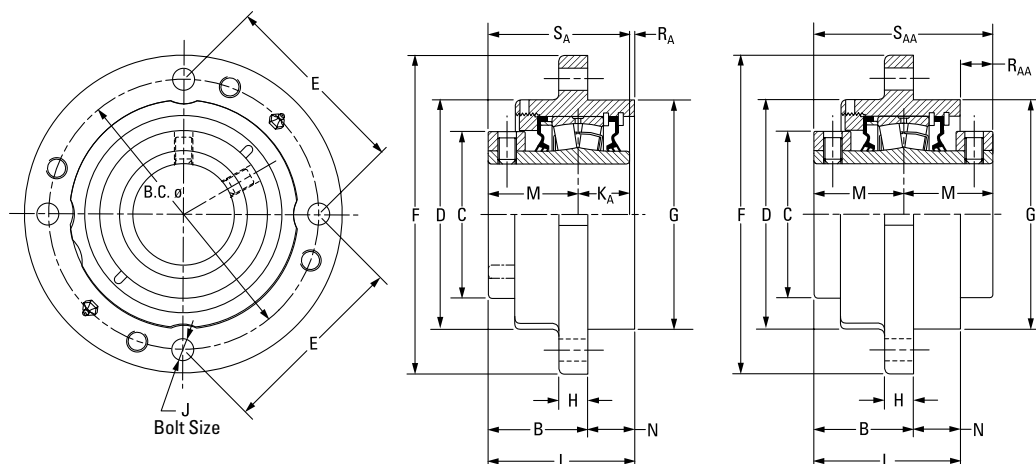

Bearing Part No. ⁽¹⁾	Shaft Dia.	Bearing No.	B FIX	B EXP	B.C.	C	D	E	F	G ⁽²⁾	H	J	KA	L FIX	L EXP	M	N	RA	RAA	SA	SAA	Wt.
	mm in.		mm in.	mm in.	mm in.	mm in.	mm in.	mm in.	mm in.	mm in.	mm in.	mm in.	mm in.	mm in.	mm in.	mm in.	mm in.	mm in.	mm in.	mm in.	mm in.	kg lbs.
QACMD08A035S	35 mm																					
QACMD08A107S	1 7/16 in.	22208	49.8 1.96	51.8 2.04	111.3 4.38	60.5 2.38	92.2 3.63	78.5 3.09	133.4 5.25	92.1 3.625	12.7 0.50	10 7/16	25.4 1.00	73.7 2.70	75.7 1.73	44.5 0.92	23.9 0.92	4.06 0.14	—	69.9 2.73	—	3.6 6
QACMD08A108S	1 1/2 in.																					
QACMD09A040S	40 mm																					
QACMD09A111S	1 1/16 in.	22209	54.6 2.15	56.6 2.23	130.3 5.13	65.0 2.56	111.3 4.38	91.9 3.62	155.7 6.13	108.0 4.250	12.7 0.50	12 1/2	25.4 1.00	77.0 3.03	79.0 3.11	47.5 1.87	22.4 0.88	4.1 0.16	—	73.2 2.88	—	4.1 9
QACMD09A112S	1 3/4 in.																					
QACMD09A045S	45 mm																					
QACMD10A115S QAACMD10A115S	1 1/16 in.																					
QACMD10A200S QAACMD10A200S	2 in.	22210	50.1 1.97	52.6 2.07	136.7 5.38	70.3 2.77	113.5 4.47	96.5 3.80	162.1 6.38	114.3 4.500	16.0 0.63	12 1/2	25.4 1.00	77.5 3.05	79.5 3.13	47.5 1.87	26.9 1.06	4.6 0.18	18.5 0.73	72.9 2.87	95.3 3.75	4.5 10
QACMD10A050S QAACMD10A050S	50 mm																					
QACMD11A203S QAACMD11A203S	2 3/16 in.																					
QACMD11A204S QAACMD11A204S	2 1/4 in.	22211	54.0 2.13	56.4 2.22	152.4 6.00	79.3 3.12	127.0 5.00	107.7 4.24	185.4 7.30	127.0 5.000	14.7 0.58	12 1/2	28.7 1.13	82.7 3.26	85.1 3.35	50.5 1.99	28.7 1.13	3.5 0.14	18.5 0.73	79.2 3.12	101.6 4.00	5.9 13
QACMD11A055S QAACMD11A055S	55 mm																					
QACMD13A060S QAACMD13A060S	60 mm																					
QACMD13A207S QAACMD13A207S	2 7/16 in.	22213	60.5 2.38	61.5 2.42	165.1 6.50	96.8 3.81	139.7 5.50	116.8 4.60	193.8 7.63	139.7 5.500	17.5 0.69	12 1/2	31.5 1.24	88.9 3.50	91.2 3.59	54.1 2.13	28.7 1.13	2.3 0.09	20.3 0.80	85.6 3.37	109.2 4.30	7.3 16
QACMD13A208S QAACMD13A208S	2 1/2 in.																					
QACMD13A065S QAACMD13A065S	65 mm																					

⁽¹⁾ Bearing part numbers use QA to designate single-collar units (use SA and RA dimensions) and QAA to designate double-collar units (use SAA and RAA dimensions).

⁽²⁾ Pilot tolerance: +0/-0.051 mm (+0/-0.002 in.).

⁽³⁾ Six-bolt housing.

Continued on next page.

QACMD AND QAACMD PILOTED FLANGE CARTRIDGES – continued

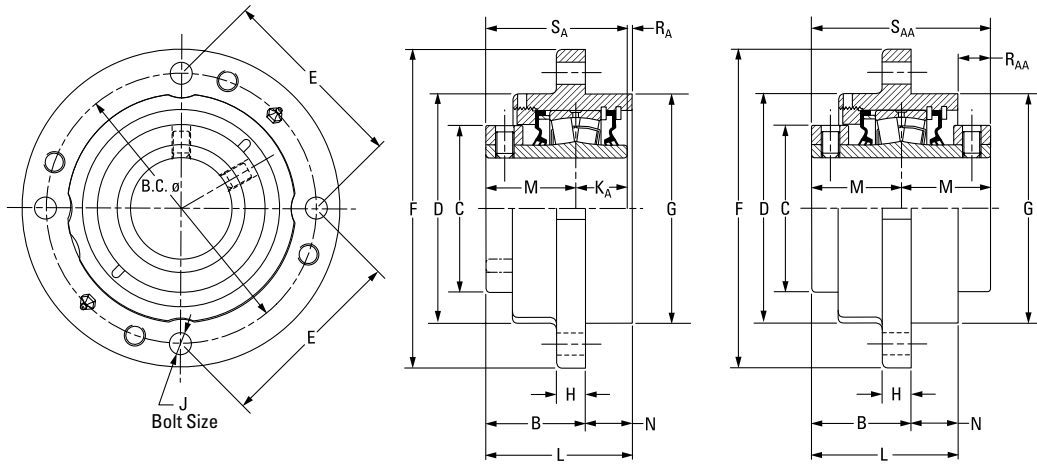

Continued from previous page.

Bearing Part No. ⁽¹⁾	Shaft Dia.	Bearing No.	B FIX	B EXP	B.C.	C	D	E	F	G ⁽²⁾	H	J	K _A	L FIX	L EXP	M	N	R _A	R _{AA}	S _A	S _{AA}	Wt.	
	mm in.		mm in.	mm in.	mm in.	mm in.	mm in.	mm in.	mm in.	mm in.	mm in.	mm in.	mm in.	mm in.	mm in.	mm in.	mm in.	mm in.	mm in.	mm in.	mm in.	mm in.	kg lbs.
QACMD15A211S QAACMD15A211S	2 1/16 in.	22215	62.5 2.46	64.5 2.54	190.5 7.50	109.0 4.29	162.1 6.38	134.6 5.30	222.3 8.75	161.9 6.375	20.6 0.81	16 5/8	31.8 1.25	94.2 3.71	96.5 3.80	60.2 2.37	31.8 1.25	2.3 0.09	21.6 0.85	91.9 3.62	120.4 4.74	10.0 22	
QACMD15A212S QAACMD15A212S	2 3/4 in.																						
QACMD15A070S QAACMD15A070S	70 mm																						
QACMD15A215S QAACMD15A215S	2 15/16 in.																						
QACMD15A300S QAACMD15A300S	3 in.																						
QACMD15A075S QAACMD15A075S	75 mm																						
QACMD18A303S QAACMD18A303S	3 3/16 in.																						22218
QACMD18A304S QAACMD18A304S	3 1/4 in.																						
QACMD18A080S QAACMD18A080S	80 mm																						
QACMD18A085S QAACMD18A085S	85 mm																						
QACMD18A307S QAACMD18A307S	3 7/16 in.																						
QACMD18A308S QAACMD18A308S	3 1/2 in.																						
QACMD18A090S QAACMD18A090S	90 mm																						

⁽¹⁾Bearing part numbers use QA to designate single-collar units (use S_A and R_A dimensions) and QAA to designate double-collar units (use S_{AA} and R_{AA} dimensions).

⁽²⁾Pilot tolerance: +0/-0.051 mm (+0/-0.002 in.).

⁽³⁾Six-bolt housing.

QACW AND QAACW PILOTED FLANGE CARTRIDGES

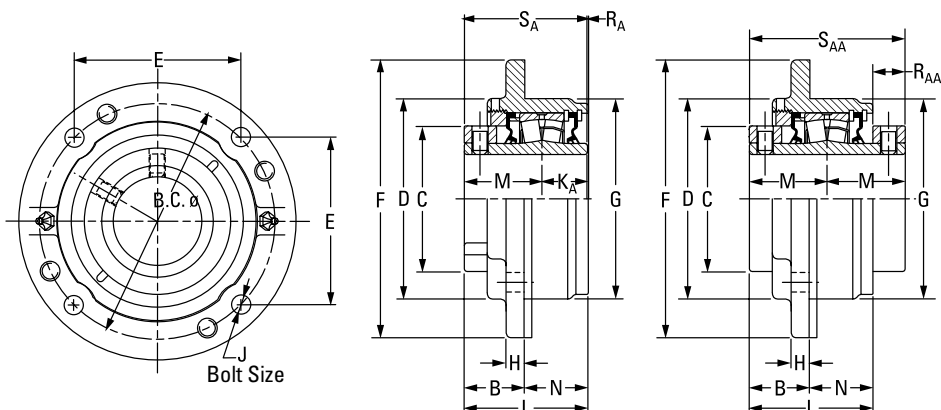

QA Single-Collar Unit

QAA Double-Collar Unit

Bearing Part No. ⁽¹⁾	Shaft Dia.	Bearing No.	B FIX	B EXP	B.C.	C	D	E	F	G ⁽²⁾	H	J	K _A	L FIX	L EXP	M	N	R _A	R _{AA}	S _A	S _{AA}	Wt.	
			mm in.	mm in.	mm in.	mm in.	mm in.	mm in.	mm in.	mm in.	mm in.	mm in.	mm in.	mm in.	mm in.	mm in.	mm in.	mm in.	mm in.	mm in.	mm in.	mm in.	kg lbs.
QACW08A035S	35 mm	22208	38.9	40.9	111.3	60.5	92.2	78.5	133.4	92.1	12.7	10	25.4	73.7	75.7	44.5	35.1	3.8	-	69.9	-	3.6	
QACW08A107S	1 3/16 in.		1.53	1.61	4.38	2.38	3.63	3.09	5.25	3.625	0.50	7/16	1.00	2.90	2.98	1.75	1.38	0.15	-	2.75	-	8	
QACW08A108S	1 1/2 in.																						
QACW09A040S	40 mm	22209	38.9	40.1	130.3	66.8	111.3	91.9	155.7	108.0	10.2	10	25.4	77.0	78.2	47.8	38.1	4.1	-	73.2	-	4.1	
QACW09A111S	1 1/8 in.		1.53	1.58	5.13	2.63	4.38	3.62	6.13	4.250	0.40	7/16	1.00	3.03	3.08	1.88	1.5	0.16	-	2.88	-	9	
QACW09A112S	1 3/4 in.																						
QACW09A045S	45 mm	22210	35.3	37.3	136.7	73.2	113.5	96.5	162.1	114.3	9.7	10	25.4	73.4	75.4	47.5	38.1	0.5	22.6	72.9	95.3	4.5	
QACW10A115S	1 5/8 in.		1.39	1.47	5.38	2.88	4.47	3.80	6.38	4.500	0.38	7/16	1.00	2.89	2.97	1.87	1.50	0.02	0.89	2.87	3.75	10	
QAACW10A115S	2 in.																						
QACW10A200S	50 mm	22211	38.9	40.9	152.4	82.6	126.7	107.7	181.1	127.0	14.2	12	28.7	80.3	82.3	50.8	41.4	0.8	14.7	79.5	101.6	5.9	
QAACW10A200S			2 3/16 in.	1.53	1.61	6.00	3.25	4.99	4.24	7.13	5.000	0.56	1/2	1.13	3.16	3.24	2.00	1.63	0.03	0.58	3.13	4.00	13
QAACW10A203S			2 1/2 in.																				
QACW11A204S	55 mm	22213	47.2	49.3	165.1	96.8	139.7	116.8	193.8	139.7	12.7	12	31.5	90.2	92.2	54.6	42.9	4.3	19.1	86.1	109.2	7.3	
QAACW11A204S			2 3/8 in.	1.86	1.94	6.50	3.81	5.50	4.60	7.63	5.500	0.50	1/2	1.24	3.55	3.63	2.15	1.69	0.17	0.75	3.39	4.30	16
QAACW11A208S			2 1/2 in.																				
QACW13A060S	60 mm	22215	46.0	48.0	190.5	109.0	162.1	134.6	222.3	161.9	12.7	16	31.8	93.5	95.5	60.2	47.8	1.5	26.9	91.9	120.4	10.0	
QAACW13A060S			2 1/8 in.	1.81	1.89	7.50	4.29	6.38	5.30	8.75	6.375	0.50	5/8	1.25	3.68	3.76	2.37	1.88	0.06	1.06	3.62	4.74	22
QAACW13A070S			2 3/4 in.																				
QACW13A207S	70 mm	22215	46.0	48.0	190.5	109.0	162.1	134.6	222.3	161.9	12.7	16	31.8	93.5	95.5	60.2	47.8	1.5	26.9	91.9	120.4	10.0	
QAACW13A207S			2 7/8 in.	1.81	1.89	7.50	4.29	6.38	5.30	8.75	6.375	0.50	5/8	1.25	3.68	3.76	2.37	1.88	0.06	1.06	3.62	4.74	22
QAACW13A208S			2 1/2 in.																				
QACW13A065S	65 mm	22215	46.0	48.0	190.5	109.0	162.1	134.6	222.3	161.9	12.7	16	31.8	93.5	95.5	60.2	47.8	1.5	26.9	91.9	120.4	10.0	
QAACW13A065S			2 5/8 in.	1.81	1.89	7.50	4.29	6.38	5.30	8.75	6.375	0.50	5/8	1.25	3.68	3.76	2.37	1.88	0.06	1.06	3.62	4.74	22
QAACW13A075S			3 in.																				
QACW15A075S	75 mm	22215	46.0	48.0	190.5	109.0	162.1	134.6	222.3	161.9	12.7	16	31.8	93.5	95.5	60.2	47.8	1.5	26.9	91.9	120.4	10.0	

⁽¹⁾Bearing part numbers use QA to designate single-collar units (use S_A and R_A dimensions) and QAA to designate double-collar units (use S_{AA} and R_{AA} dimensions).

Continued on next page.

⁽²⁾Pilot tolerance: +0/-0.051 mm (+0/-0.002 in.).

⁽³⁾Six-bolt housing.

QACW AND QAACW PILOTED FLANGE CARTRIDGES – continued

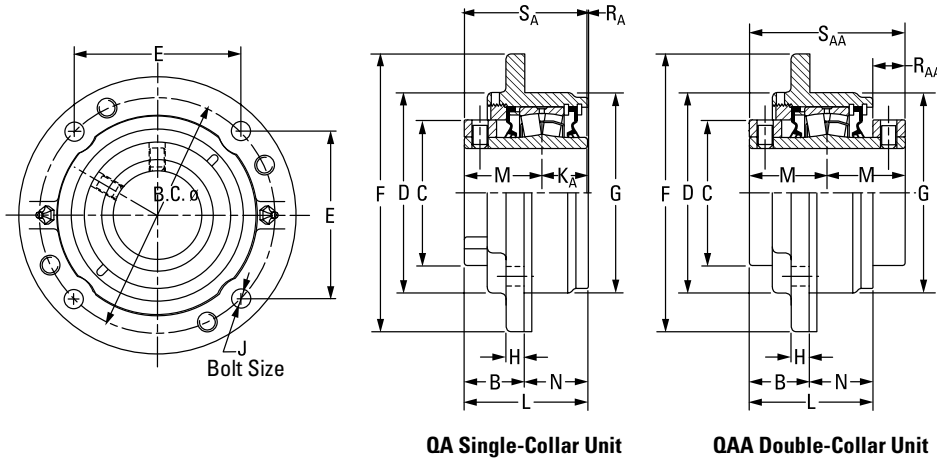

Continued from previous page.

Bearing Part No. ⁽¹⁾	Shaft Dia.	Bearing No.	B FIX	B EXP	B.C.	C	D	E	F	G ⁽²⁾	H	J	K _A	L FIX	L EXP	M	N	R _A	R _{AA}	S _A	S _{AA}	Wt.																					
	mm in.		mm in.	mm in.	mm in.	mm in.	mm in.	mm in.	mm in.	mm in.	mm in.	mm in.	mm in.	mm in.	mm in.	mm in.	mm in.	mm in.	mm in.	mm in.	mm in.	mm in.	kg lbs.																				
QACW18A303S QAACW18A303S	3 3/16 in.	22218	58.2 2.29	60.2 2.37	219.2 8.63	130.3 5.13	187.5 7.38	154.9 6.10	260.4 10.25	187.3 7.375	22.4 0.88	20 3/4	36.6 1.44	105.9 4.17	108.0 4.25	65.8 2.59	47.8 1.88	3.3 0.13	21.3 0.84	102.4 4.03	131.6 5.18	14.5 32																					
QACW18A304S QAACW18A304S	3 1/4 in.																																										
QACW18A080S QAACW18A080S	80 mm																																										
QACW18A085S QAACW18A085S	85 mm																																										
QACW18A307S QAACW18A307S	3 7/16 in.																																										
QACW18A308S QAACW18A308S	3 1/2 in.																																										
QACW18A090S QAACW18A090S	90 mm																																										
QACW20A315S QAACW20A315S	3 15/16 in.																						22220	65.5 2.58	67.6 2.66	238.3 9.38	152.4 6.00	206.5 8.13	168.4 6.63	276.4 10.88	206.4 8.125	25.4 1.00	20 3/4	41.4 1.63	123.4 4.86	125.5 4.94	75.4 2.97	57.9 2.28	6.9 0.27	30.2 1.19	116.6 4.59	150.9 5.94	19.5 43
QACW20A400S QAACW20A400S	4 in.																																										
QACW20A100S QAACW20A100S	100 mm																																										
QACW22A110S QAACW22A407S ⁽³⁾	4 7/16 in.	22222	62.0 2.44	64.0 2.52	298.5 11.75 ⁽³⁾	160.0 6.30	254.0 10.00	149.4 5.88 ⁽³⁾	342.9 13.50	260.4 10.250	25.4 1.00	20 3/4 ⁽³⁾	-	130.0 5.12	132.1 5.20	79.5 3.13	68.3 2.69	-	28.7 1.13	-	158.8 6.25	32.7 72																					
QAACW22A408S ⁽³⁾	4 1/2 in.																																										
QAACW22A115S ⁽³⁾	115 mm																																										
QACW26A125S ⁽³⁾ QAACW26A415S ⁽³⁾	4 15/16 in.	22226	73.7 2.90	75.7 2.98	323.9 12.75 ⁽³⁾	175.0 6.89	266.7 10.50	162.1 6.38 ⁽³⁾	374.7 14.75	279.4 11.000	26.2 1.03	24 7/8 ⁽³⁾	-	153.2 6.03	155.2 6.11	94.5 3.72	78.0 3.07	-	35.8 1.41	-	189.0 7.44	46.3 102																					
QAACW26A500S ⁽³⁾	5 in.																																										
QAACW26A130S ⁽³⁾	130 mm																																										

⁽¹⁾Bearing part numbers use QA to designate single-collar units (use S_A and R_A dimensions) and QAA to designate double-collar units (use S_{AA} and R_{AA} dimensions).

⁽²⁾Pilot tolerance: +0/-0.051 mm (+0/-0.002 in.).

⁽³⁾Six-bolt housing.

QAF AND QAAF SQUARE FLANGE BLOCKS

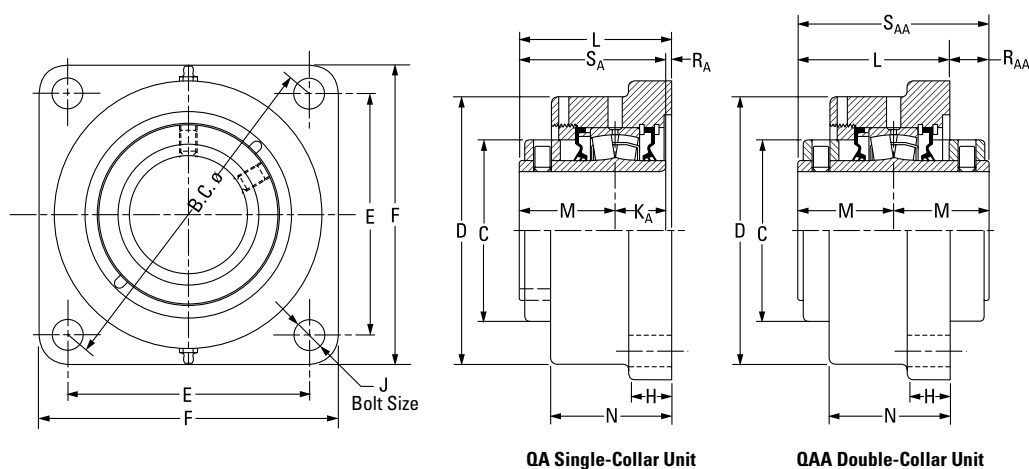

QA Single-Collar Unit

QAA Double-Collar Unit

Bearing Part No. ⁽¹⁾	Shaft Dia.	Bearing No.	B.C.	C	D	E	F	H	J	K _A	L FIX	L EXP	M	N	R _A	R _{AA}	S _A	S _{AA}	Wt.																	
	mm in.		mm in.	mm in.	mm in.	mm in.	mm in.	mm in.	mm in.	mm in.	mm in.	mm in.	mm in.	mm in.	mm in.	mm in.	mm in.	mm in.	mm in.	kg lbs.																
QAF08A035S	35 mm	22208	125.7	60.5	93.7	88.9	117.6	22.4	12	25.4	72.9	74.9	44.5	57.2	3.0	-	69.9	-	4.5																	
QAF08A107S	1 7/16 in.		4.95	2.38	3.69	3.50	4.63	0.88	1/2	1.00	2.87	2.95	1.75	2.25	0.12	-	2.75	-	10																	
QAF08A108S	1 1/2 in.	22208	148.3	60.5	108.0	104.9	136.7	22.4	12	25.4	73.7	75.7	44.5	59.4	3.8	-	69.9	-	4.5																	
			5.84	2.38	4.25	4.13	5.38	0.88	1/2	1.00	2.90	2.98	1.75	2.34	0.15	-	2.75	-	10																	
QAF09A040S	40 mm	22209	148.3	66.8	118.4	104.9	136.7	22.4	12	25.4	79.5	81.5	47.8	63.5	6.4	-	73.2	-	5.0																	
QAF09A111S	1 1/16 in.		5.84	2.63	4.66	4.13	5.38	0.88	1/2	1.00	3.13	3.21	1.88	2.50	0.25	-	2.88	-	11																	
QAF09A112S	1 3/4 in.	22209	157.2	66.8	118.4	111.3	143.0	22.4	12	25.4	79.5	81.5	47.8	63.5	6.4	-	73.2	-	5.0																	
QAF09A045S	45 mm		6.19	2.63	4.66	4.38	5.63	0.88	1/2	1.00	3.13	3.21	1.88	2.50	0.25	-	2.88	-	11																	
QAF10A115S	1 1/16 in.	22210	157.2	73.2	120.7	111.3	139.7	22.4	12	25.4	80.8	82.8	47.5	65.0	7.9	15.2	72.9	95.3	5.0																	
QAAF10A115S																																				
QAF10A200S	2 in.		6.19	2.88	4.75	4.38	5.50	0.88	1/2	1.00	3.18	3.26	1.87	2.56	0.31	0.60	2.87	3.75	11																	
QAF10A050S	50 mm																																			
QAF11A203S	2 3/16 in.	22211	175.0	82.6	130.3	124.0	157.2	25.4	16	28.7	83.1	85.1	50.8	66.8	3.8	18.5	79.5	101.6	6.4																	
QAAF11A203S																																				
QAF11A204S	2 1/4 in.		6.89	3.25	5.13	4.88	6.19	1.00	5/8	1.13	3.27	3.35	2.00	2.63	0.15	0.73	3.13	4.00	14																	
QAF11A055S	55 mm																																			
QAF11A055S																																				
QAF13A060S	60 mm	22213	193.0	96.8	146.1	136.7	168.4	25.4	16	31.5	89.2	91.2	54.6	72.4	3.0	20.1	86.1	109.2	7.7																	
QAAF13A060S																																				
QAF13A207S	2 7/16 in.																			7.60	3.81	5.75	5.38	6.63	1.00	5/8	1.24	3.51	3.59	2.15	2.85	0.12	0.79	3.39	4.30	17
QAAF13A207S																																				
QAF13A208S	2 1/2 in.																																			
QAAF13A208S																																				
QAF13A065S	65 mm																																			
QAAF13A065S																																				

⁽¹⁾ Bearing part numbers use QA to designate single-collar units (use S_A and R_A dimensions) and QAA to designate double-collar units (use S_{AA} and R_{AA} dimensions).

Continued on next page.

QAF AND QAAF SQUARE FLANGE BLOCKS – continued

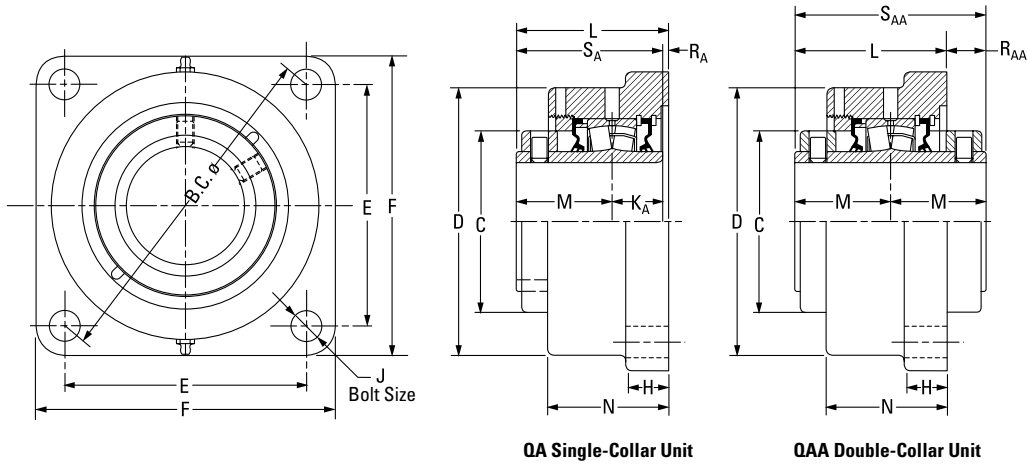

Continued from previous page.

Bearing Part No. ⁽¹⁾	Shaft Dia.	Bearing No.	B.C.	C	D	E	F	H	J	K _A	L FIX	L EXP	M	N	R _A	R _{AA}	S _A	S _{AA}	Wt.																		
	mm in.		mm in.	mm in.	mm in.	mm in.	mm in.	mm in.	mm in.	mm in.	mm in.	mm in.	mm in.	mm in.	mm in.	mm in.	mm in.	mm in.	kg lbs.																		
QAF15A211S QAAF15A211S	2 1/16 in.	22215	215.4 8.48	109.0 4.29	168.9 6.65	152.4 6.00	189.0 7.44	26.9 1.06	20 3/4	31.8 1.25	95.8 3.77	97.8 3.85	60.2 2.37	76.2 3.00	3.8 0.15	24.6 0.97	91.9 3.62	120.4 4.74	10.4 23																		
QAF15A212S QAAF15A212S	2 3/4 in.																																				
QAF15A070S QAAF15A070S	70 mm																																				
QAF15A215S QAAF15A215S	2 15/16 in.																																				
QAF15A300S QAAF15A300S	3 in.																																				
QAF15A075S QAAF15A075S	75 mm																																				
QAF18A303S QAAF18A303S	3 3/16 in.																			22218	251.7 9.91	130.3 5.13	193.8 7.63	177.8 7.00	219.2 8.63	33.3 1.31	20 3/4	36.6 1.44	107.2 4.22	109.2 4.30	65.8 2.59	84.1 3.31	4.8 0.19	24.4 0.96	102.4 4.03	131.6 5.18	15.9 35
QAF18A304S QAAF18A304S	3 1/4 in.																																				
QAF18A080S QAAF18A080S	80 mm																																				
QAF18A085S QAAF18A085S	85 mm																																				
QAF18A307S QAAF18A307S	3 7/16 in.																																				
QAF18A308S QAAF18A308S	3 1/2 in.																																				
QAF18A090S QAAF18A090S	90 mm																																				
QAF20A315S QAAF20A315S	3 15/16 in.	22220	278.4 10.96	152.4 6.00	224.0 8.82	196.9 7.75	253.2 9.97	38.1 1.50	24 7/8	41.4 1.63	126.0 4.96	128.0 5.04	75.4 2.97	103.1 4.06	9.4 0.37	24.1 0.95	116.6 4.59	150.4 5.92	24.9 55																		
QAF20A400S QAAF20A400S	4 in.																																				
QAF20A100S QAAF20A100S	100 mm																																				
QAAF22A110S	110 mm	22222	314.5 12.38	155.70 6.13	256.8 10.11	222.3 8.75	276.4 10.88	38.1 1.50	24 7/8	-	135.6 5.34	137.7 5.42	79.5 3.13	106.9 4.21	-	23.4 0.92	-	158.8 6.25	28.6 63																		
QAF22A407S	4 7/16 in.																																				
QAF22A408S QAAF22A115S	4 1/2 in. 115 mm																																				

⁽¹⁾Bearing part numbers use QA to designate single-collar units (use S_A and R_A dimensions) and QAA to designate double-collar units (use S_{AA} and R_{AA} dimensions).

QAFE AND QAAFE SQUARE FLANGE BLOCKS

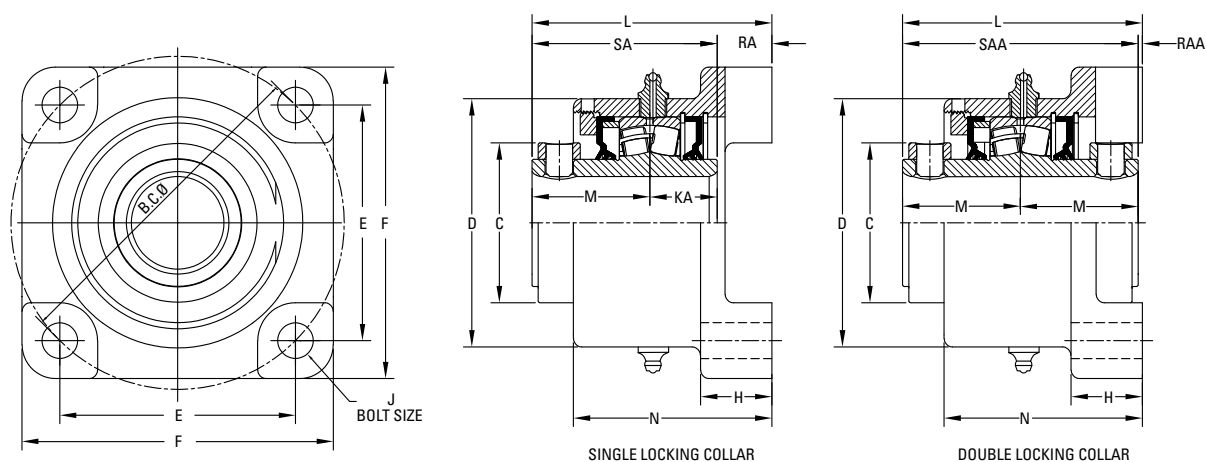

Bearing Part No. ⁽¹⁾	Shaft Dia.	Bearing No.	B.C.	C	D	E	F	H	J	K _A	L FIX	L EXP	M	N	R _A	R _{AA}	S _A	S _{AA}	Wt.	
	mm in.		mm in.	mm in.	mm in.	mm in.	mm in.	mm in.	mm in.	mm in.	mm in.	mm in.	mm in.	mm in.	mm in.	mm in.	mm in.	mm in.	mm in.	kg lbs.
QAFE08A035S	35 mm	22208	125.7	60.5	93.7	88.9	117.6	25.8	M12	25.4	90.5	93.1	44.5	74.9	20.7	-	69.9	-	2.8	
QAFE08A107S	1 7/16 in.		4.95	2.38	3.69	3.50	4.63	1.06	1/2	1.00	3.56	3.67	1.75	2.95	0.81	-	2.75	-	6	
QAFE08A108S	1 1/2 in.	22208	148.3	60.5	108.0	104.9	136.7	30.2	M12	25.4	90.5	94.6	44.5	76.4	20.7	-	69.9	-	4.5	
			5.84	2.38	4.25	4.13	5.38	1.19	1/2	1.00	3.56	3.73	1.75	3.01	0.81	-	2.75	-	10	
QAFE09A111S	1 1/16 in.	22209	148.3	66.8	118.4	104.9	136.7	30.2	M12	25.4	96.3	101.9	47.8	80.5	23.3	-	73.2	-	5.0	
QAFE09A040S	40 mm		5.84	2.63	4.66	4.13	5.38	1.19	1/2	1.00	3.79	4.01	1.88	3.17	0.92	-	2.88	-	11	
QAFE09A112S	1 3/4 in.	22209	157.2	66.8	118.4	111.3	143.0	30.2	M12	25.4	96.3	101.9	47.8	80.5	23.3	-	73.2	-	5.3	
QAFE09A045S	45 mm		6.19	2.63	4.66	4.38	5.63	1.19	1/2	1.00	3.79	4.01	1.88	3.17	0.92	-	2.88	-	12	
QAFE10A115S	1 1/16 in.	22210	157.2	73.2	120.7	111.3	139.7	30.2	M12	25.4	97.3	102.8	47.8	81.8	24.3	1.9	72.9	95.3	5.5	
QAAFE10A115S																				
QAFE10A200S	2 in.		6.19	2.88	4.75	4.38	5.50	1.19	1/2	1.00	3.83	4.05	1.88	3.22	0.96	0.07	2.87	3.75	12	
QAAFE10A200S																				
QAFE10A050S	50 mm	22211	175.0	82.6	130.3	124.0	157.2	34.9	M16	28.7	105.0	110.5	50.8	85.7	25.6	3.4	79.5	101.6	6.9	
QAAFE10A050S																				
QAFE11A203S	2 3/16 in.		6.89	3.25	5.13	4.88	6.19	1.38	5/8	1.13	4.13	4.35	2.00	3.38	1.01	0.14	3.13	4.00	15	
QAAFE11A203S																				
QAFE11A204S	2 1/4 in.																			
QAAFE11A204S																				
QAFE11A055S	55 mm	22213	193.0	96.8	146.1	136.7	168.4	38.1	M16	31.5	114.2	116.2	54.6	97.8	28.5	5.3	86.1	109.2	8.9	
QAAFE11A055S																				
QAFE13A060S	60 mm		7.60	3.81	5.75	5.38	6.63	1.50	5/8	1.24	4.50	4.57	2.15	3.85	1.12	0.21	3.39	4.30	20	
QAAFE13A060S																				
QAFE13A207S	2 7/16 in.																			
QAAFE13A207S																				
QAFE13A208S	2 1/2 in.																			
QAAFE13A208S																				
QAFE13A065S	65 mm																			
QAAFE13A065S																				

⁽¹⁾Bearing part numbers use QA to designate single-collar units (use S_A and R_A dimensions) and QAA to designate double-collar units (use S_{AA} and R_{AA} dimensions).

Continued on next page.

QAFE AND QAAFE SQUARE FLANGE BLOCKS – continued

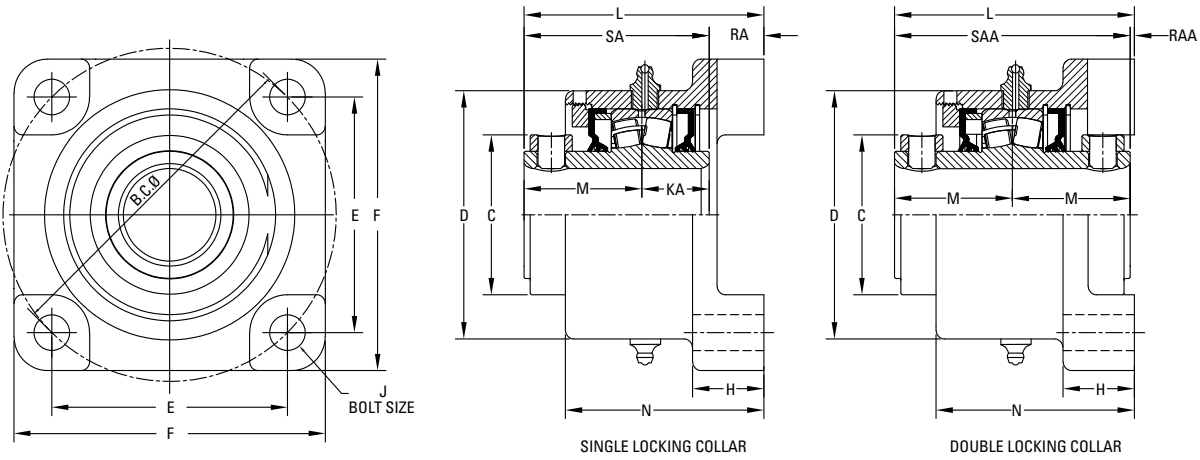

Continued from previous page.

Bearing Part No. ⁽¹⁾	Shaft Dia.	Bearing No.	B.C.	C	D	E	F	H	J	K _A	L FIX	L EXP	M	N	R _A	R _{AA}	S _A	S _{AA}	Wt.	
	mm in.		mm in.	mm in.	mm in.	mm in.	mm in.	mm in.	mm in.	mm in.	mm in.	mm in.	mm in.	mm in.	mm in.	mm in.	mm in.	mm in.	mm in.	kg lbs.
QAFE15A211S QAAFE15A211S	2 1/16 in.	22215	215.4 8.48	109.0 4.29	170.7 6.72	152.4 6.00	189.0 7.44	41.3 1.63	M20 3/4	31.8 1.25	122.9 4.84	125.9 4.92	60.2 2.37	103.2 4.06	30.9 1.22	2.5 0.10	91.9 3.62	120.4 4.74	12.4 27	
QAFE15A212S QAAFE15A212S	2 3/4 in.																			
QAFE15A070S QAAFE15A070S	70 mm																			
QAFE15A215S QAAFE15A215S	2 15/16 in.																			
QAFE15A300S QAAFE15A300S	3 in.																			
QAFE15A075S QAAFE15A075S	75 mm																			
QAFE18A303S QAAFE18A303S	3 3/16 in.	22218	251.7 9.91	130.3 5.13	193.8 7.63	177.8 7.00	219.2 8.63	47.6 1.88	M20 3/4	36.6 1.44	135.0 5.31	136.9 5.39	65.8 2.59	111.8 4.40	32.5 1.28	3.3 0.13	102.4 4.03	131.6 5.18	18.1 40	
QAFE18A304S QAAFE18A304S	3 1/4 in.																			
QAFE18A080S QAAFE18A080S	80 mm																			
QAFE18A085S QAAFE18A085S	85 mm																			
QAFE18A307S QAAFE18A307S	3 7/16 in.																			
QAFE18A308S QAAFE18A308S	3 1/2 in.																			
QAFE18A090S QAAFE18A090S	90 mm	22220	278.4 10.96	152.4 6.00	224.0 8.82	196.9 7.75	253.2 9.97	54.0 2.13	M24 7/8	41.3 1.62	154.7 6.09	156.8 6.17	75.4 2.97	131.8 5.19	38.0 1.50	3.8 0.15	116.6 4.59	150.8 5.94	27.3 60	
QAFE20A315S QAAFE20A315S	3 15/16 in.																			
QAFE20A400S QAAFE20A400S	4 in.																			
QAFE20A100S QAAFE20A100S	100 mm																			
QAAFE22A110S	110 mm																			
QAAFE22A407S QAAFE22A408S	4 7/16 in. 4 1/2 in.																			22222
QAAFE22A115S	115 mm																			

⁽¹⁾Bearing part numbers use QA to designate single-collar units (use S_A and R_A dimensions) and QAA to designate double-collar units (use S_{AA} and R_{AA} dimensions).

QAFL AND QAAFL SQUARE FLANGE BLOCKS

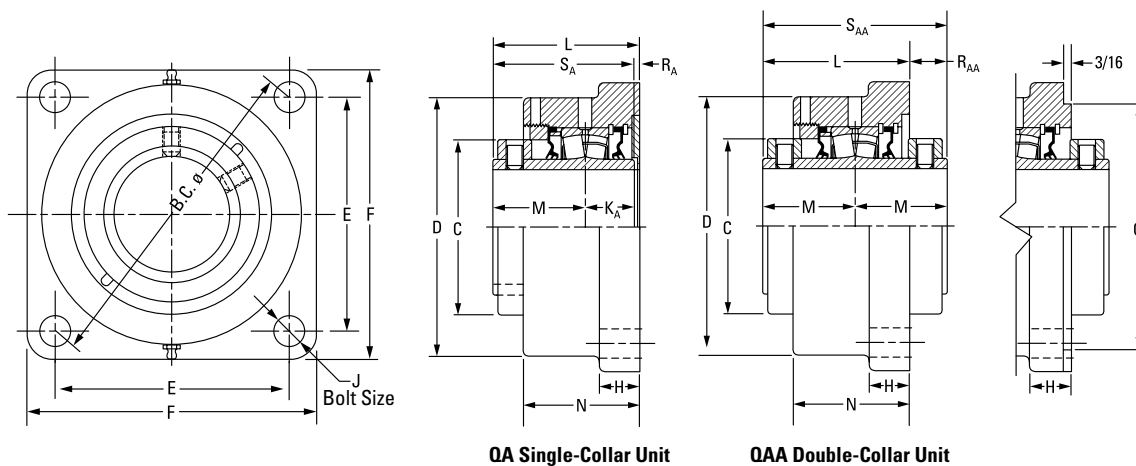

QA Single-Collar Unit

QAA Double-Collar Unit

Bearing Part No. ⁽¹⁾	Shaft Dia.	Bearing No.	B.C.	C	D	E	F	G ⁽²⁾⁽³⁾⁽⁴⁾	H	J	K _A	L FIX	L EXP	M	N	R _A	R _{AA}	S _A	S _{AA}	Wt.
	mm in.		mm in.	mm in.	mm in.	mm in.	mm in.	mm in.	mm in.	mm in.	mm in.	mm in.	mm in.	mm in.	mm in.	mm in.	mm in.	mm in.	mm in.	kg lbs.
QAFL08A035S	35 mm	22208	127.0	60.5	93.7	89.9	117.6	N/A	22.4	12	25.4	72.9	74.9	44.5	57.2	3.0	—	69.9	—	4.5
QAFL08A107S	1 7/16 in.		5.00	2.38	3.69	3.54	4.63	0.88	1/2	1.00	2.87	2.95	1.75	2.25	0.12	—	2.75	—	10	
QAFL08A108S	1 1/2 in.																			
QAFL09A040S	40 mm	22209	139.7	66.8	118.4	98.8	136.7	N/A	22.4	12	25.4	79.5	81.5	47.8	63.5	6.6	—	73.2	—	5.0
QAFL09A111S	1 1/4 in.		5.50	2.63	4.66	3.89	5.38	0.88	1/2	1.00	3.13	3.21	1.88	2.50	0.26	—	2.88	—	11	
QAFL09A112S	1 3/4 in.																			
QAFL09A045S	45 mm																			
QAFL10A115S	1 5/16 in.	22210	146.1	73.2	115.3	103.4	131.8	N/A	23.1	12	25.4	80.8	82.8	47.5	62.5	7.9	15.2	72.9	95.3	5.0
QAFL10A200S	2 in.		5.75	2.88	4.54	4.07	5.19	0.91	1/2	1.00	3.18	3.26	1.87	2.46	0.31	0.60	2.87	3.75	11	
QAFL10A050S	50 mm																			
QAFL11A203S	2 3/16 in.	22211	162.1	82.6	131.8	114.3	149.4	N/A	19.1	16	28.7	83.3	85.3	50.8	66.8	3.8	18.3	79.5	101.6	6.4
QAFL11A204S	2 1/4 in.		6.38	3.25	5.19	4.50	5.88	0.75	5/8	1.13	3.28	3.36	2.00	2.63	0.15	0.72	3.13	4.00	14	
QAFL11A055S	55 mm																			
QAFL13A060S	60 mm	22213	171.5	96.8	146.1	121.2	157.2	N/A	25.4	16	31.5	89.2	91.2	54.6	72.6	3.0	20.1	86.1	109.2	7.7
QAFL13A207S	2 7/16 in.		6.75	3.81	5.75	4.77	6.19	1.00	5/8	1.24	3.51	3.59	2.15	2.86	0.12	0.79	3.39	4.30	17	
QAFL13A208S	2 1/2 in.																			
QAFL13A065S	65 mm																			

⁽¹⁾ Bearing part numbers use QA to designate single-collar units (use S_A and R_A dimensions) and QAA to designate double-collar units (use S_{AA} and R_{AA} dimensions).

⁽²⁾ Pilot tolerance: +0/-0.05 mm (+0/-0.002 in.).

⁽³⁾ Add (p) to the end of the housing designation in the part number to order with pilot using G dimension.

⁽⁴⁾ Piloted flange blocks will be quoted (price and delivery) upon request. For optional spigot on flange side, insert the letter P as seen in the following example: QMFP**J***S.

Continued on next page.

QAFL AND QAAFL SQUARE FLANGE BLOCKS – continued

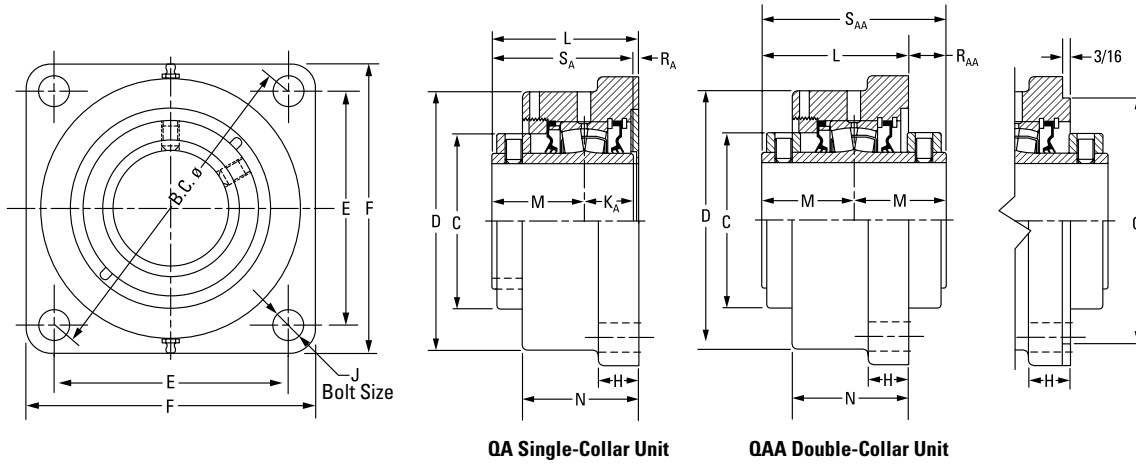

Continued from previous page.

Bearing Part No. ⁽¹⁾	Shaft Dia.	Bearing No.	B.C.	C	D	E	F	G ⁽²⁾⁽³⁾⁽⁴⁾	H	J	K _A	L FIX	L EXP	M	N	R _A	R _{AA}	S _A	S _{AA}	Wt.	
	mm in.		mm in.	mm in.	mm in.	mm in.	mm in.	mm in.	mm in.	mm in.	mm in.	mm in.	mm in.	mm in.	mm in.	mm in.	mm in.	mm in.	mm in.	mm in.	kg lbs.
QAFL15A211S QAAFL15A211S	2 1/16 in.	22215	200.2 7.88	109.0 4.29	168.4 6.63	141.2 5.56	182.6 7.19	N/A	26.9 1.06	20 3/4	31.8 1.25	95.8 3.77	97.8 3.85	60.2 2.37	74.4 2.93	3.8 0.15	24.6 0.97	91.9 3.62	120.4 4.74	10.4 23	
QAFL15A212S QAAFL15A212S	2 3/4 in.																				
QAFL15A070S QAAFL15A070S	70 mm																				
QAFL15A215S QAAFL15A215S	2 15/16 in.																				
QAFL15A300S QAAFL15A300S	3 in.																				
QAFL15A075S QAAFL15A075S	75 mm																				
QAFL18A303S QAAFL18A303S	3 3/16 in.	22218	241.3 9.50	130.3 5.13	193.8 7.63	170.7 6.72	212.9 8.38	187.33 7.375	32.5 1.28	20 3/4	36.6 1.44	106.4 4.19	108.5 4.27	65.8 2.59	86.4 3.40	4.1 0.16	25.1 0.99	102.4 4.03	131.6 5.18	15.9 35	
QAFL18A304S QAAFL18A304S	3 1/4 in.																				
QAFL18A080S QAAFL18A080S	80 mm																				
QAFL18A085S QAAFL18A085S	85 mm																				
QAFL18A307S QAAFL18A307S	3 7/16 in.																				
QAFL18A308S QAAFL18A308S	3 1/2 in.																				
QAFL18A090S QAAFL18A090S	90 mm	22220	273.1 10.75	152.4 6.00	229.6 9.04	193.0 7.60	241.3 9.50	215.90 8.500	38.1 1.50	24 1	41.4 1.63	132.3 5.21	134.4 5.29	75.4 2.97	104.6 4.12	15.7 0.62	18.0 0.71	116.6 4.59	150.4 5.92	24.9 55	
QAFL20A315S QAAFL20A315S	3 15/16 in.																				
QAFL20A400S QAAFL20A400S	4 in.																				
QAFL20A100S QAAFL20A100S	100 mm																				

⁽¹⁾ Bearing part numbers use QA to designate single-collar units (use S_A and R_A dimensions) and QAA to designate double-collar units (use S_{AA} and R_{AA} dimensions).

⁽²⁾ Pilot tolerance: +0/-0.05 mm (+0/-0.002 in.).

⁽³⁾ Add (p) to the end of the housing designation in the part number to order with pilot using G dimension.

⁽⁴⁾ Piloted flange blocks will be quoted (price and delivery) upon request. For optional spigot on flange side, insert the letter P as seen in the following example: QAFL**A***S

QAFMD AND QAAFMD SQUARE FLANGE BLOCKS

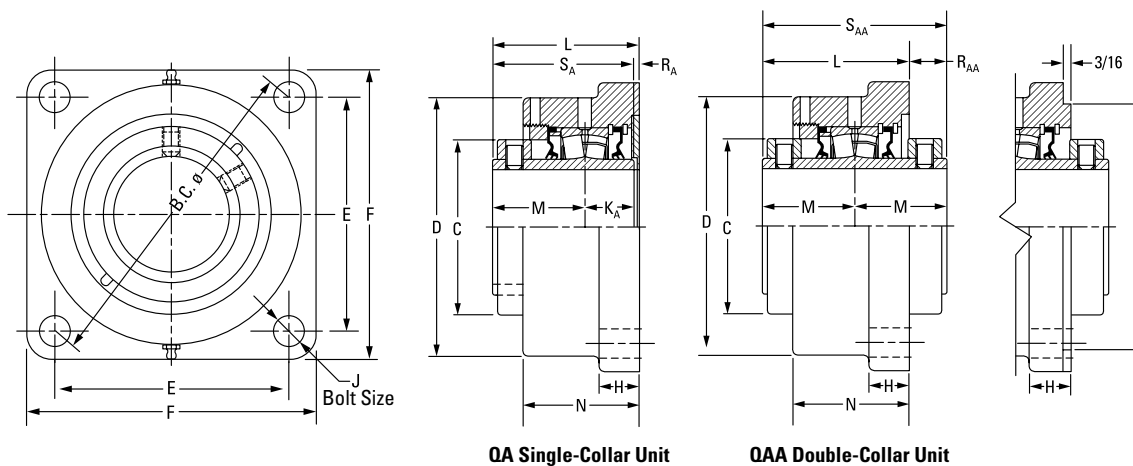

Bearing Part No. ⁽¹⁾	Shaft Dia.	Bearing No.	B.C.	C	D	E	F	H	J	KA	L FIX	L EXP	M	N	RA	RAA	SA	SAA	Wt.
	mm in.		mm in.	mm in.	mm in.	mm in.	mm in.	mm in.	mm in.	mm in.	mm in.	mm in.	mm in.	mm in.	mm in.	mm in.	mm in.	mm in.	kg lbs.
QAFMD08A035S	35 mm	22208	143.8	60.5	108.0	101.6	130.3	22.4	12	25.4	72.9	74.9	44.5	59.4	3.0	-	69.9	-	4.5
QAFMD08A107S	1 7/16 in.		5.66	2.38	4.25	4.00	5.13	0.88	1/2	1	2.87	2.95	1.75	2.34	0.12	-	2.75	-	10
QAFMD08A108S	1 1/2 in.	22208	148.3	60.5	108.0	104.9	136.7	22.4	12	25.4	73.7	75.9	44.5	59.4	3.8	-	69.9	-	4.5
QAFMD09A040S	40 mm		5.84	2.38	4.25	4.13	5.38	0.88	1/2	1	2.90	2.98	1.76	2.34	0.15	-	2.75	-	10
QAFMD09A110S	1 5/8 in.	22209	148.3	66.8	108.0	104.9	136.7	22.4	12	25.4	79.5	81.5	47.8	63.5	6.4	-	73.2	-	5.0
QAFMD09A045S	45 mm		5.84	2.63	4.25	4.13	5.38	0.88	1/2	1	3.13	3.21	1.88	2.50	0.25	-	2.88	-	11
QAFMD09A111S	1 11/16 in.	22209	157.2	66.8	118.4	111.3	143.0	22.4	12	25.4	79.5	81.5	47.8	63.5	6.4	-	73.2	-	5.0
QAFMD09A112S	1 3/4 in.		6.19	2.63	4.66	4.38	5.63	0.88	1/2	1	3.13	3.21	1.88	2.50	0.25	-	2.88	-	11
QAFMD10A115S	1 15/16 in.	22210	184.1	73.2	120.7	130.2	165.1	22.4	16	25.4	80.8	82.8	47.5	65.0	7.9	15.2	72.9	95.3	5.0
QAFMD10A200S	2 in.		7.25	2.88	4.75	5.13	6.50	0.88	5/8	1.00	3.18	3.26	1.87	2.56	0.31	0.60	2.87	3.75	11
QAFMD10A050S	50 mm	22211	202.1	82.6	137.9	142.9	174.8	25.4	16	28.7	83.1	85.1	50.8	66.8	3.8	18.5	79.5	101.6	6.4
QAFMD11A203S	2 3/8 in.		7.96	3.25	5.43	5.63	6.88	1.00	5/8	1.13	3.27	3.35	2.00	2.63	0.15	0.73	3.13	4.00	14
QAFMD11A204S	2 1/4 in.	22213	211.0	96.8	146.1	149.2	187.5	25.4	16	31.5	89.2	91.2	54.6	72.4	3.0	20.1	86.1	109.2	7.7
QAFMD11A055S	55 mm		8.31	3.81	5.75	5.88	7.38	1.00	5/8	1.24	3.51	3.59	2.15	2.85	0.12	0.79	3.39	4.30	17
QAFMD13A060S	60 mm	22213	211.0	96.8	146.1	149.2	187.5	25.4	16	31.5	89.2	91.2	54.6	72.4	3.0	20.1	86.1	109.2	7.7
QAFMD13A207S	2 7/8 in.		8.31	3.81	5.75	5.88	7.38	1.00	5/8	1.24	3.51	3.59	2.15	2.85	0.12	0.79	3.39	4.30	17
QAFMD13A208S	2 1/2 in.	22213	211.0	96.8	146.1	149.2	187.5	25.4	16	31.5	89.2	91.2	54.6	72.4	3.0	20.1	86.1	109.2	7.7
QAFMD13A065S	65 mm		8.31	3.81	5.75	5.88	7.38	1.00	5/8	1.24	3.51	3.59	2.15	2.85	0.12	0.79	3.39	4.30	17

⁽¹⁾Bearing part numbers use QA to designate single-collar units (use SA and RA dimensions) and QAA to designate double-collar units (use SAA and RAA dimensions).

Continued on next page.

QAFMD AND QAAFMD SQUARE FLANGE BLOCKS – continued

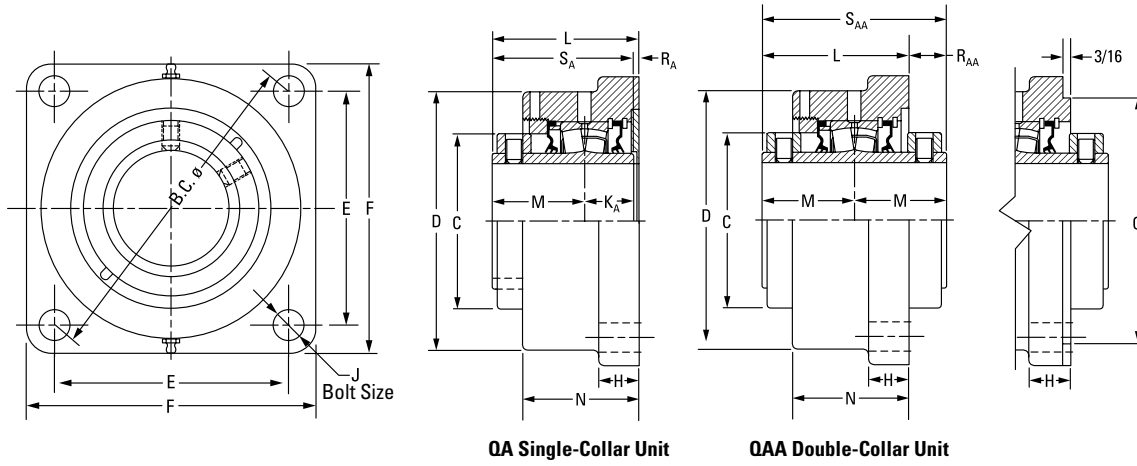

Continued from previous page.

Bearing Part No. ⁽¹⁾	Shaft Dia.	Bearing No.	B.C.	C	D	E	F	H	J	K _A	L FIX	L EXP	M	N	R _A	R _{AA}	S _A	S _{AA}	Wt.
	mm in.		mm in.	mm in.	mm in.	mm in.	mm in.	mm in.	mm in.	mm in.	mm in.	mm in.	mm in.	mm in.	mm in.	mm in.	mm in.	mm in.	kg lbs.
QAFMD15A211S QAAFMD15A211S	2 1/16 in.	22215	215.4 8.48	109.0 4.29	168.9 6.65	152.4 6.00	189.0 7.44	26.9 1.06	20 3/4	31.8 1.25	95.8 3.77	97.8 3.85	60.2 2.37	76.2 3.00	3.8 0.15	24.6 0.97	91.9 3.62	120.4 4.74	10.4 23
QAFMD15A212S QAAFMD15A212S	2 3/4 in.																		
QAFMD15A070S QAAFMD15A070S	70 mm																		
QAFMD15A215S QAAFMD15A215S	2 15/16 in.																		
QAFMD15A300S QAAFMD15A300S	3 in.																		
QAFMD15A075S QAAFMD15A075S	75 mm																		
QAFMD18A303S QAAFMD18A303S	3 3/16 in.	22218	241.3 9.50	130.2 5.13	193.8 7.63	171.5 6.72	212.7 8.38	32.5 1.28	20 3/4	36.6 1.44	106.4 4.19	108.5 4.27	65.8 2.59	86.4 3.40	4.3 0.17	25.0 0.94	102.4 4.03	131.6 5.18	15.9 35
QAFMD18A304S QAAFMD18A304S	3 1/4 in.																		
QAFMD18A080S QAAFMD18A080S	80 mm																		
QAFMD18A085S QAAFMD18A085S	85 mm																		
QAFMD18A307S QAAFMD18A307S	3 7/16 in.																		
QAFMD18A308S QAAFMD18A308S	3 1/2 in.																		
QAFMD18A090S QAAFMD18A090S	90 mm																		

⁽¹⁾Bearing part numbers use QA to designate single-collar units (use S_A and R_A dimensions) and QAA to designate double-collar units (use S_{AA} and R_{AA} dimensions).

QAAF 5000 SERIES FLANGE BLOCKS

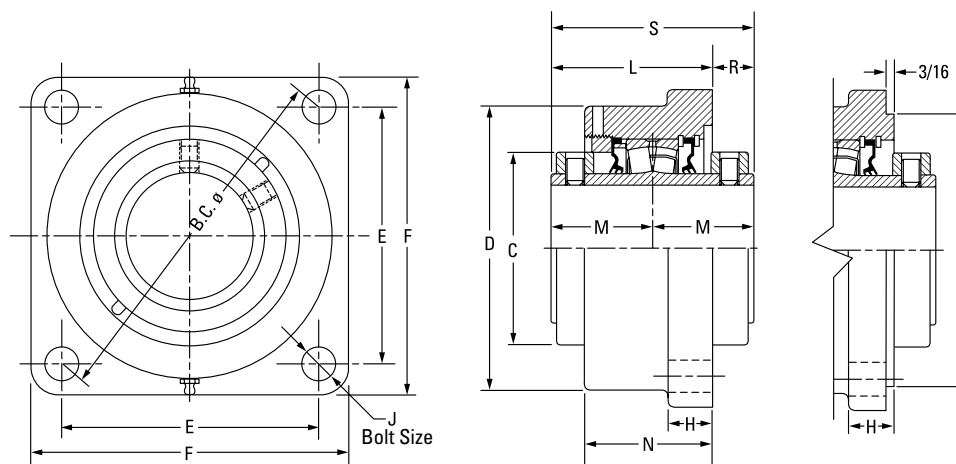

Bearing Part No.	Shaft Dia.	Bearing No.	B.C.	C	D	E	F	G ⁽¹⁾⁽²⁾⁽³⁾	H	J	L FIX	L EXP	M	N	R	S	Wt.
	mm in.		mm in.	mm in.	mm in.	mm in.	mm in.	mm in.	mm in.	mm in.	mm in.	mm in.	mm in.	mm in.	mm in.	mm in.	kg lbs.
QAAF10A115S	1 1/16 in.	22210	146.1	73.2	120.7	103.1	134.9	111.13	22.4	12	80.8	82.8	47.5	65.0	15.2	95.3	5.4
QAAF10A200S	2 in.		5.75	2.88	4.75	4.06	5.31	4.375	0.88	1/2	3.18	3.26	1.87	2.56	0.60	3.75	12
QAAF10A050S	50 mm																
QAAF11A203S	2 3/16 in.	22211	161.5	82.6	130.3	114.3	149.4	127.00	25.4	16	83.1	85.1	50.5	66.8	18.5	101.6	6.8
QAAF11A204S	2 1/4 in.		6.36	3.25	5.13	4.50	5.88	5.000	1.00	5/8	3.27	3.35	1.99	2.63	0.73	4.00	15
QAAF11A055S	55 mm																
QAAF13A060S	60 mm	22213	180.8	96.8	146.1	127.8	157.2	138.13	25.4	16	89.2	91.2	54.6	72.4	19.6	109.2	8.6
QAAF13A207S	2 7/16 in.		7.12	3.81	5.75	5.03	6.19	5.438	1.00	5/8	3.51	3.59	2.15	2.85	0.77	4.30	19
QAAF13A208S	2 1/2 in.																
QAAF13A065S	65 mm																
QAAF15A211S	2 1/16 in.	22215	215.9	109.0	168.9	152.7	189.0	160.35	26.9	20	96.0	98.0	60.2	76.2	24.4	120.4	12.7
QAAF15A212S	2 3/4 in.		8.50	4.29	6.65	6.01	7.44	6.313	1.06	3/4	3.78	3.86	2.37	3.00	0.96	4.74	28
QAAF15A070S	70 mm																
QAAF15A215S	2 15/16 in.																
QAAF15A300S	3 in.																
QAAF15A075S	75 mm																
QAAF18A303S	3 3/16 in.	22218	241.3	130.3	193.8	170.7	212.9	187.33	33.3	20	107.2	109.2	65.8	84.1	24.6	131.6	19.1
QAAF18A304S	3 1/4 in.		9.50	5.13	7.63	6.72	8.38	7.375	1.31	3/4	4.22	4.30	2.59	3.31	0.97	5.18	42
QAAF18A080S	80 mm																
QAAF18A085S	85 mm																
QAAF18A307S	3 7/16 in.																
QAAF18A308S	3 1/2 in.																
QAAF18A090S	90 mm																
QAAF20A315S	3 15/16 in.	22220	298.5	152.4	215.9	211.1	268.2	225.43	38.1	24	126.0	128.0	75.4	103.1	24.6	150.4	29.9
QAAF20A400S	4 in.		11.75	6.00	8.50	8.31	10.56	8.875	1.50	7/8	4.96	5.04	2.97	4.06	0.97	5.92	66
QAAF20A100S	100 mm																
QAAF22A110S	110 mm																
QAAF22A407S ⁽⁴⁾	4 7/16 in.	22222	327.2	160.0	256.5	163.6	384.3	263.53	31.8	24	143.8	145.8	94.0	106.9	15.0	158.8	46.3
QAAF22A408S ⁽⁴⁾	4 1/2 in.		12.88 ⁽⁴⁾	6.30	10.10	6.44 ⁽⁴⁾	15.13	10.375	1.25	7/8	5.66	5.74	3.70	4.21	0.59	6.25	102
QAAF22A115S ⁽⁴⁾	115 mm																
QAAF26A125S ⁽⁴⁾	125 mm																
QAAF26A415S ⁽⁴⁾	4 15/16 in.	22226	355.6	175.0	284.2	177.8	419.1	284.18	38.1	24	174.8	176.8	94.5	135.1	14.2	189.0	52.2
QAAF26A500S ⁽⁴⁾	5 in.		14.00 ⁽⁴⁾	6.89	11.19	7.00 ⁽⁴⁾	16.50	11.188	1.50	1	6.88	6.96	3.72	5.32	0.56	7.44	115
QAAF26A130S ⁽⁴⁾	130 mm																

⁽¹⁾Pilot tolerance: +0/-0.05 mm (+0/-0.002 in.).⁽²⁾Add (p) to the end of the housing designation in the part number to order with pilot using G dimension.⁽³⁾Piloted flange blocks will be quoted (price and delivery) upon request. For optional spigot on flange side, insert the letter P as seen in the following example: QMFP**J***S.⁽⁴⁾Six-bolt round housing.

QAFY AND QAAFY ROUND FLANGE BLOCKS

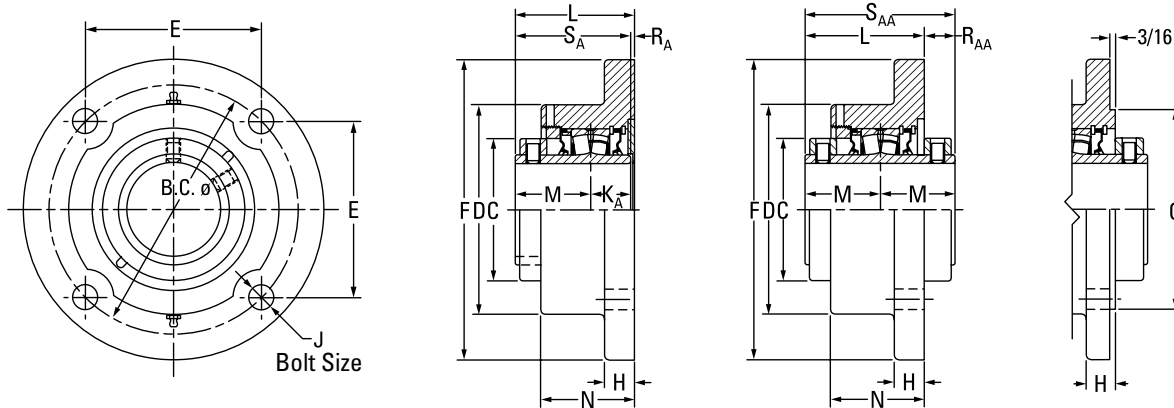

QA Single-Collar Unit

QAA Double-Collar Unit

Bearing Part No. ⁽¹⁾	Shaft Dia.	Bearing No.	B.C.	C	D	E	F	G ⁽²⁾⁽³⁾⁽⁴⁾	H	J	KA	L FIX	L EXP	M	N	RA	RAA	SA	SAA	Wt.	
	mm in.		mm in.	mm in.	mm in.	mm in.	mm in.	mm in.	mm in.	mm in.	mm in.	mm in.	mm in.	mm in.	mm in.	mm in.	mm in.	mm in.	mm in.	mm in.	kg lbs.
QAFY08A035S ⁽⁵⁾	35 mm	22208	127.0	60.5	108.0	110.0	158.8	90.50	19.1	12	25.4	73.2	75.2	44.5	57.4	3.3	-	69.9	-	4.5	
QAFY08A107S ⁽⁵⁾	1 7/16 in.		5.00	2.38	4.25	4.33	6.25	3.563	0.75	1/2	1.00	2.88	2.96	1.75	2.26	0.13	-	2.75	-	10	
QAFY08A108S ⁽⁵⁾	1 1/2 in.																				
QAFY09A040S	40 mm	22209	139.7	66.8	104.9	98.8	171.5	103.20	20.6	12	25.4	76.2	78.2	47.8	60.5	3.0	-	73.2	-	5.0	
QAFY09A111S	1 11/16 in.		5.50	2.63	4.13	3.89	6.75	4.063	0.81	1/2	1.00	3.00	3.08	1.88	2.38	0.12	-	2.88	-	11	
QAFY09A112S	1 3/4 in.																				
QAFY09A045S	45 mm	22210	146.1	73.2	115.3	103.4	177.8	111.13	19.1	12	25.4	75.9	78.0	47.5	57.2	3.0	20.1	72.9	95.3	5.4	
QAFY10A115S	1 15/16 in.		5.75	2.88	4.54	4.07	7.00	4.375	0.75	1/2	1.00	2.99	3.07	1.87	2.25	0.12	0.79	2.87	3.75	12	
QAFY10A200S	2 in.																				
QAFY10A050S	50 mm	22211	162.1	82.6	130.3	114.3	196.9	127.00	19.1	16	28.7	82.3	84.3	50.8	62.0	3.0	19.3	79.5	101.6	6.8	
QAFY11A204S	2 1/4 in.		6.38	3.25	5.13	4.50	7.75	5.000	0.75	5/8	1.13	3.24	3.32	2.00	2.44	0.12	0.76	3.13	4.00	15	
QAFY11A055S	55 mm																				
QAFY13A060S	60 mm	22213	171.5	96.8	146.1	121.2	206.5	138.13	23.9	16	31.5	91.2	93.2	54.6	72.4	5.1	20.6	86.1	109.2	8.6	
QAFY13A207S	2 7/16 in.		6.75	3.81	5.75	4.77	8.13	5.438	0.94	5/8	1.24	3.49	3.67	2.15	2.85	0.20	0.81	3.39	4.30	19	
QAFY13A208S	2 1/2 in.																				
QAFY13A065S	65 mm																				

⁽¹⁾Bearing part numbers use QA to designate single-collar units (use SA and RA dimensions) and QAA to designate double-collar units (use SAA and RAA dimensions).

⁽²⁾Pilot tolerance: +0/-0.05 mm (+0/-0.002 in.).

⁽³⁾Add (p) to the end of the housing designation in the part number to order with pilot using G dimension.

⁽⁴⁾Piloted flange blocks will be quoted (price and delivery) upon request. For optional spigot on flange side, insert the letter P as seen in the following example: QMFP**J***S.

⁽⁵⁾Three-bolt housing.

⁽⁶⁾Six-bolt housing.

QAFY AND QAAFY ROUND FLANGE BLOCKS

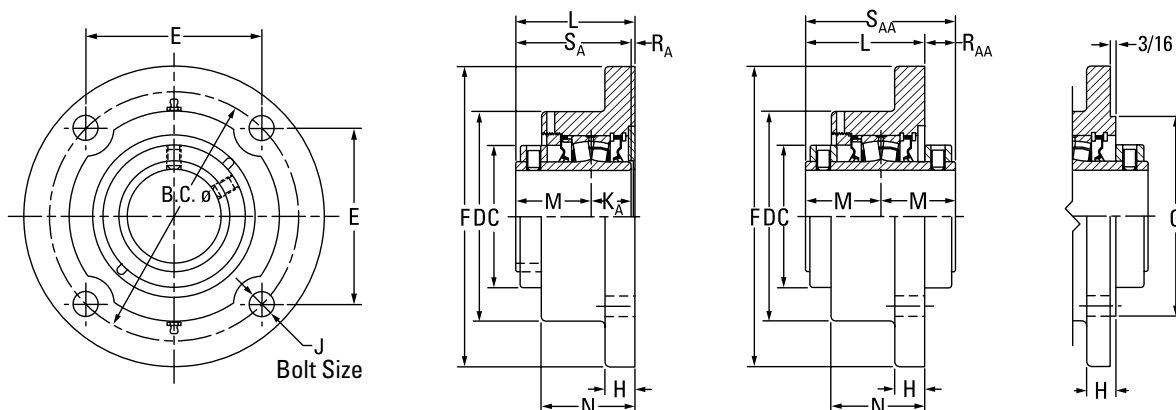

QA Single-Collar Unit

QAA Double-Collar Unit

Bearing Part No. ⁽¹⁾	Shaft Dia.	Bearing No.	B.C.	C	D	E	F	G ⁽²⁾⁽³⁾⁽⁴⁾	H	J	KA	L FIX	L EXP	M	N	RA	RAA	SA	SAA	Wt.
	mm in.		mm in.	mm in.	mm in.	mm in.	mm in.	mm in.	mm in.	mm in.	mm in.	mm in.	mm in.	mm in.	mm in.	mm in.	mm in.	mm in.	mm in.	kg lbs.
QAFY15A211S QAAFY15A211S	2 1/16 in.	22215	200.2 7.88	109.0 4.29	168.4 6.63	141.5 5.57	241.3 9.50	160.35 6.313	23.9 0.94	20 3/4	31.8 1.25	98.3 3.87	100.3 3.95	60.2 2.37	74.4 2.93	6.4 0.25	21.8 0.86	91.9 3.62	120.4 4.74	12.7 28
QAFY15A212S QAAFY15A212S	2 3/4 in.																			
QAFY15A070S QAAFY15A070S	70 mm																			
QAFY15A215S QAAFY15A215S	2 15/16 in.																			
QAFY15A300S QAAFY15A300S	3 in.																			
QAFY15A075S QAAFY15A075S	75 mm																			
QAFY18A303S QAAFY18A303S	3 3/16 in.	22218	241.3 9.50	130.3 5.13	193.8 7.63	170.7 6.72	282.7 11.13	N/A	28.7 1.13	24 7/8	36.6 1.44	108.7 4.28	110.7 4.36	65.8 2.59	85.3 3.36	6.4 0.25	22.9 0.90	102.4 4.03	131.6 5.18	19.1 42
QAFY18A304S QAAFY18A304S	3 1/4 in.																			
QAFY18A080S QAAFY18A080S	80 mm																			
QAFY18A085S QAAFY18A085S	85 mm																			
QAFY18A307S QAAFY18A307S	3 7/16 in.																			
QAFY18A308S QAAFY18A308S	3 1/2 in.																			
QAFY18A090S QAAFY18A090S	90 mm	22220	273.1 10.75	152.4 6.00	222.5 8.76	193.0 7.60	320.8 12.63	N/A	28.7 1.13	24 1	41.4 1.63	123.7 4.87	125.7 4.95	75.4 2.97	103.1 4.06	6.9 0.27	26.7 1.05	116.6 4.59	150.4 5.92	29.9 66
QAFY20A315S QAAFY20A315S	3 15/16 in.																			
QAFY20A400S QAAFY20A400S	4 in.																			
QAFY20A100S QAAFY20A100S	100 mm																			
QAFY22A110S ⁽⁶⁾ QAAFY22A110S ⁽⁶⁾	110 mm																			
QAFY22A407S ⁽⁶⁾ QAAFY22A407S ⁽⁶⁾	4 7/16 in.																			
QAFY22A408S ⁽⁶⁾ QAAFY22A408S ⁽⁶⁾	4 1/2 in.	22222	327.2 12.88 ⁽⁵⁾	160.0 6.30	254.0 10.00	163.6 6.44 ⁽⁵⁾	384.3 15.13	N/A	31.8 1.25	24 1 ⁽⁵⁾	-	129.0 5.08	131.1 5.16	79.5 3.13	100.3 3.95	-	30.0 1.18	-	158.8 6.25	46.3 102
QAFY22A115S ⁽⁶⁾ QAAFY22A115S ⁽⁶⁾	115 mm																			
QAFY26A125S ⁽⁶⁾ QAAFY26A125S ⁽⁶⁾	125 mm	22226	355.6 14.00 ⁽⁵⁾	175.0 6.89	284.2 11.19	177.8 7.00 ⁽⁵⁾	419.1 16.50	N/A	38.1 1.50	27 1 1/8 ⁽⁵⁾	-	169.9 6.69	172.0 6.77	94.5 3.72	139.7 5.50	-	19.1 0.75	-	189.0 7.44	52.2 115
QAFY26A415S ⁽⁶⁾ QAAFY26A415S ⁽⁶⁾	4 15/16 in.																			
QAFY26A500S ⁽⁶⁾ QAAFY26A500S ⁽⁶⁾	5 in.																			
QAFY26A130S ⁽⁶⁾ QAAFY26A130S ⁽⁶⁾	130 mm																			

⁽¹⁾Bearing part numbers use QA to designate single-collar units (use SA and RA dimensions) and QAA to designate double-collar units (use SAA and RAA dimensions).

⁽²⁾Pilot tolerance: +0/-0.05 mm (+0/-0.002 in.).

⁽³⁾Add (p) to the end of the housing designation in the part number to order with pilot using G dimension.

⁽⁴⁾Piloted flange blocks will be quoted (price and delivery) upon request. For optional spigot on flange side, insert the letter P as seen in the following example: QMFP**J***S.

⁽⁵⁾Three-bolt housing.

⁽⁶⁾Six-bolt housing.

QAMC AND QAAMC CARTRIDGE BLOCKS

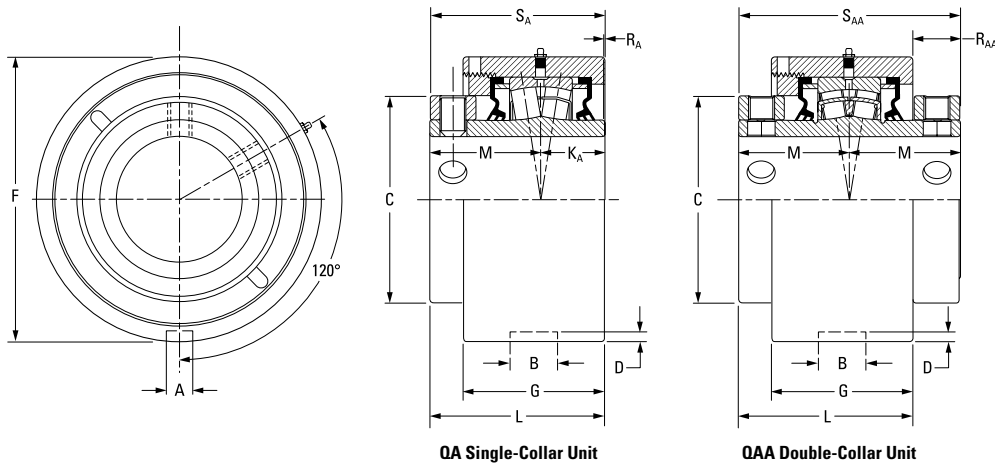

QA Single-Collar Unit

QAA Double-Collar Unit

Bearing Part No. ⁽¹⁾	Shaft Dia.	Bearing No.	A	B	C	D	F	G	KA	L FIX	L EXP	M	RA	RAA	SA	SAA	Wt.	
	mm in.		mm in.	mm in.	mm in.	mm in.	mm in.	mm in.	mm in.	mm in.	mm in.	mm in.	mm in.	mm in.	mm in.	mm in.	kg lbs.	
QAMC10A115S QAAMC10A115S	1 15/16 in.	22210	13.5	23.1	73.2	4.8	104.78 (+0/-0.05)	62.2	25.4	79.2	81.3	47.5	6.1	16.8	72.9	95.3	3.6	
QAMC10A200S QAAMC10A200S	2 in.		0.53	0.91	2.88	0.19	4.125 (+0/-0.002)	2.45	1.00	3.12	3.20	1.87	0.24	0.66	2.87	3.75	8	
QAMC10A050S QAAMC10A050S	50 mm																	
QAMC11A203S QAAMC11A203S	2 3/16 in.	22211	13.5	23.1	82.6	4.8	115.09 (+0/-0.05)	65.5	28.7	83.8	85.9	50.8	4.1	18.0	79.5	101.6	4.5	
QAMC11A204S QAAMC11A204S	2 1/4 in.		0.53	0.91	3.25	0.19	4.531 (+0/-0.002)	2.58	1.13	3.30	3.38	2.00	0.16	0.71	3.13	4.00	10	
QAMC11A055S QAAMC11A055S	55 mm																	
QAMC13A060S QAAMC13A060S	60 mm	22213	13.5	23.1	96.8	3.6	127.00 (+0/-0.05)	69.3	31.5	85.9	87.9	54.6	0.0	14.0	86.1	109.2	5.4	
QAMC13A207S QAAMC13A207S	2 7/16 in.		0.53	0.91	3.81	0.14	5.000 (+0/-0.002)	2.73	1.24	3.38	3.46	2.15	0.00	0.55	3.39	4.30	12	
QAMC13A208S QAAMC13A208S	2 1/2 in.																	
QAMC13A065S QAAMC13A065S	65 mm																	
QAMC15A211S QAAMC15A211S	2 11/16 in.	22215	15.0	26.2	109.0	6.4	149.225 (+0/-0.05)	79.8	31.8	100.6	102.6	60.2	8.1	19.8	91.9	120.4	8.2	
QAMC15A212S QAAMC15A212S	2 3/4 in.		0.59	1.03	4.29	0.25	5.875 (+0/-0.002)	3.14	1.25	3.96	4.04	2.37	0.32	0.78	3.62	4.74	18	
QAMC15A070S QAAMC15A070S	70 mm																	
QAMC15A215S QAAMC15A215S	2 15/16 in.																	
QAMC15A300S QAAMC15A300S	3 in.																	
QAMC15A075S QAAMC15A075S	75 mm																	

⁽¹⁾Bearing part numbers use QA to designate single-collar units (use SA and RA dimensions) and QAA to designate double-collar units (use SAA and RAA dimensions).

QAMC AND QAAMC CARTRIDGE BLOCKS

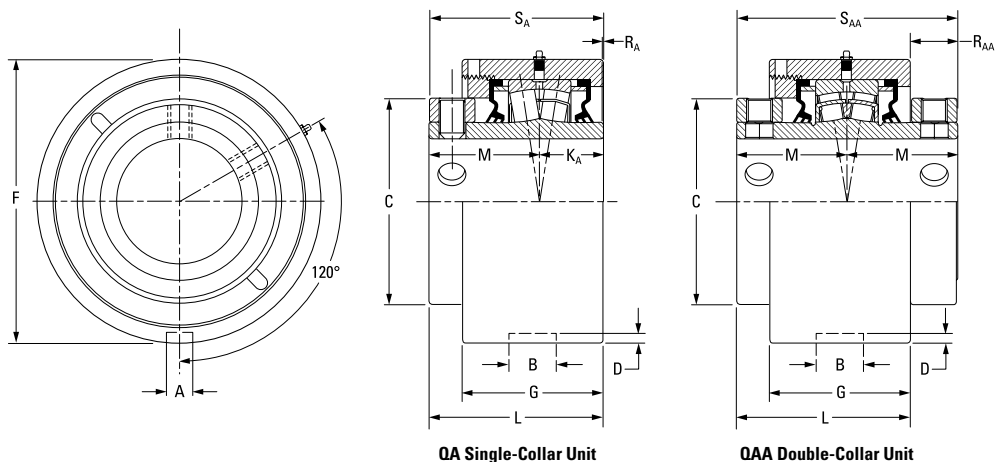

Bearing Part No. ⁽¹⁾	Shaft Dia.	Bearing No.	A	B	C	D	F	G	KA	L FIX	L EXP	M	RA	RAA	SA	SAA	Wt.
			mm in.	mm in.	mm in.	mm in.	mm in.	mm in.	mm in.	mm in.	mm in.	mm in.	mm in.	mm in.	mm in.	mm in.	mm in.
QAMC18A303S QAAMC18A303S	3 3/16 in.	22218	15.0 0.59	26.9 1.06	130.3 5.13	5.8 0.23	171.45 (+0/-0.05) 6.750 (+0/-0.002)	87.6 3.45	36.6 1.44	110.2 4.34	112.3 4.42	65.8 2.59	7.4 0.29	21.3 0.84	102.4 4.03	131.6 5.18	11.8 26
QAMC18A304S QAAMC18A304S	3 1/4 in.																
QAMC18A080S QAAMC18A080S	80 mm																
QAMC18A085S QAAMC18A085S	85 mm																
QAMC18A307S QAAMC18A307S	3 7/16 in.																
QAMC18A308S QAAMC18A308S	3 1/2 in.																
QAMC18A090S QAAMC18A090S	90 mm																
QAMC20A315S QAAMC20A315S	3 15/16 in.	22220	19.8 0.78	32.5 1.28	152.4 6.00	7.9 0.31	206.375 (+0/-0.05) 8.125 (+0/-0.002)	105.2 4.14	41.4 1.63	128.3 5.05	130.3 5.13	75.4 2.97	11.4 0.45	22.6 0.89	116.6 4.59	150.9 5.94	14.5 32
QAMC20A400S QAAMC20A400S	4 in.																
QAMC20A100S QAAMC20A100S	100 mm																
QAAMC22A110S	110 mm	22222	19.8 0.78	38.1 1.50	160.0 6.30	7.9 0.31	222.25 (+0/-0.08) 8.75 (+0/-0.003)	108.5 4.27	-	133.6 5.26	135.6 5.34	79.5 3.13	-	25.1 0.99	-	158.8 6.25	18.1 40
QAAMC22A407S	4 7/16 in.																
QAAMC22A408S	4 1/2 in.																
QAAMC22A115S	115 mm	22226	19.8 0.78	38.1 1.50	175.0 6.89	7.9 0.31	265.13 (+0/-0.08) 10.438 (+0/-0.003)	141.7 5.58	-	165.4 6.51	167.4 6.59	94.5 3.72	-	23.6 0.93	-	189.0 7.44	18.1 40
QAAMC26A125S	125 mm																
QAAMC26A415S	4 15/16 in.																
QAAMC26A500S	5 in.																
QAAMC26A130S	130 mm																

⁽¹⁾Bearing part numbers use QA to designate single-collar units (use SA and RA dimensions) and QAA to designate double-collar units (use SAA and RAA dimensions).

QATU AND QAATU TAKE-UP BLOCKS

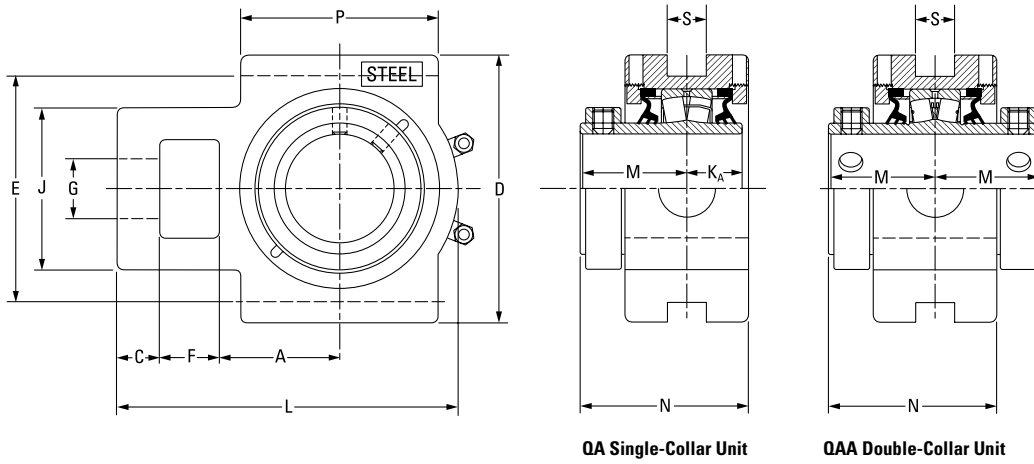

Bearing Part No. ⁽¹⁾	Shaft Dia.	Bearing No.	A	C	D	E	F	G	J	K _A	L	M	N	P	S	Wt.
			mm in.	mm in.	mm in.	mm in.	mm in.	mm in.	mm in.	mm in.	mm in.	mm in.	mm in.	mm in.	mm in.	mm in.
QATU10A115S QAATU10A115S	1 15/16 in.	22210	54.1 2.13	19.1 0.75	120.7 4.75	101.6 4.00	26.9 1.06	26.9 1.06	73.2 2.88	25.4 1.00	153.4 6.04	47.5 1.87	75.7 2.98	88.9 3.50	17.5 0.69	7.7 17
QATU10A200S QAATU10A200S	2 in.		60.5 2.38	19.1 0.75	133.4 5.25	114.3 4.50	28.7 1.13	30.2 1.19	88.9 3.50	28.7 1.13	167.9 6.61	50.8 2.00	81.8 3.22	95.3 3.75	20.6 0.81	9.5 21
QATU11A203S QAATU11A203S	2 3/16 in.		69.9 2.75	22.4 0.88	149.4 5.88	130.3 5.13	33.3 1.31	35.1 1.38	95.3 3.75	31.5 1.24	193.8 7.63	54.6 2.15	91.2 3.59	120.7 4.75	26.9 1.06	12.2 27
QATU11A204S QAATU11A204S	2 1/4 in.	22213	76.2 3.00	25.4 1.00	171.5 6.75	150.9 5.94	39.6 1.56	39.6 1.56	108.0 4.25	31.8 1.25	219.7 8.65	60.2 2.37	97.0 3.82	120.7 4.75	46.0 1.81	15.9 35
QATU11A055S QAATU11A055S	55 mm		76.2 3.00	25.4 1.00	171.5 6.75	150.9 5.94	39.6 1.56	39.6 1.56	108.0 4.25	31.8 1.25	219.7 8.65	60.2 2.37	97.0 3.82	120.7 4.75	46.0 1.81	15.9 35
QATU13A060S QAATU13A060S	60 mm		76.2 3.00	25.4 1.00	171.5 6.75	150.9 5.94	39.6 1.56	39.6 1.56	108.0 4.25	31.8 1.25	219.7 8.65	60.2 2.37	97.0 3.82	120.7 4.75	46.0 1.81	15.9 35
QATU13A207S QAATU13A207S	2 7/16 in.	22215	76.2 3.00	25.4 1.00	171.5 6.75	150.9 5.94	39.6 1.56	39.6 1.56	108.0 4.25	31.8 1.25	219.7 8.65	60.2 2.37	97.0 3.82	120.7 4.75	46.0 1.81	15.9 35
QATU13A208S QAATU13A208S	2 1/2 in.		76.2 3.00	25.4 1.00	171.5 6.75	150.9 5.94	39.6 1.56	39.6 1.56	108.0 4.25	31.8 1.25	219.7 8.65	60.2 2.37	97.0 3.82	120.7 4.75	46.0 1.81	15.9 35
QATU13A065S QAATU13A065S	65 mm		76.2 3.00	25.4 1.00	171.5 6.75	150.9 5.94	39.6 1.56	39.6 1.56	108.0 4.25	31.8 1.25	219.7 8.65	60.2 2.37	97.0 3.82	120.7 4.75	46.0 1.81	15.9 35
QATU15A211S QAATU15A211S	2 11/16 in.	22215	76.2 3.00	25.4 1.00	171.5 6.75	150.9 5.94	39.6 1.56	39.6 1.56	108.0 4.25	31.8 1.25	219.7 8.65	60.2 2.37	97.0 3.82	120.7 4.75	46.0 1.81	15.9 35
QATU15A212S QAATU15A212S	2 3/4 in.		76.2 3.00	25.4 1.00	171.5 6.75	150.9 5.94	39.6 1.56	39.6 1.56	108.0 4.25	31.8 1.25	219.7 8.65	60.2 2.37	97.0 3.82	120.7 4.75	46.0 1.81	15.9 35
QATU15A070S QAATU15A070S	70 mm		76.2 3.00	25.4 1.00	171.5 6.75	150.9 5.94	39.6 1.56	39.6 1.56	108.0 4.25	31.8 1.25	219.7 8.65	60.2 2.37	97.0 3.82	120.7 4.75	46.0 1.81	15.9 35
QATU15A215S QAATU15A215S	2 15/16 in.		76.2 3.00	25.4 1.00	171.5 6.75	150.9 5.94	39.6 1.56	39.6 1.56	108.0 4.25	31.8 1.25	219.7 8.65	60.2 2.37	97.0 3.82	120.7 4.75	46.0 1.81	15.9 35
QATU15A300S QAATU15A300S	3 in.		76.2 3.00	25.4 1.00	171.5 6.75	150.9 5.94	39.6 1.56	39.6 1.56	108.0 4.25	31.8 1.25	219.7 8.65	60.2 2.37	97.0 3.82	120.7 4.75	46.0 1.81	15.9 35
QATU15A075S QAATU15A075S	75 mm	76.2 3.00	25.4 1.00	171.5 6.75	150.9 5.94	39.6 1.56	39.6 1.56	108.0 4.25	31.8 1.25	219.7 8.65	60.2 2.37	97.0 3.82	120.7 4.75	46.0 1.81	15.9 35	

⁽¹⁾Bearing part numbers use QA to designate single-collar units and QAA to designate double-collar units.
NOTE: Please refer to page 250 for take-up frames.

QATU AND QAATU TAKE-UP BLOCKS

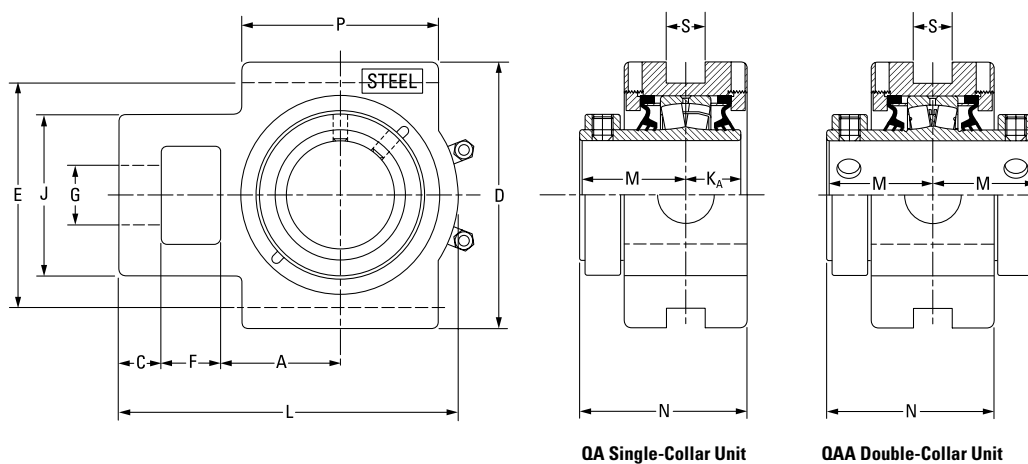

Bearing Part No. ⁽¹⁾	Shaft Dia.	Bearing No.	A	C	D	E	F	G	J	KA	L	M	N	P	S	Wt.
	mm in.		mm in.	mm in.	mm in.	mm in.	mm in.	mm in.	mm in.	mm in.	mm in.	mm in.	mm in.	mm in.	mm in.	kg lbs.
QATU18A303S QAATU18A303S	3 3/16 in.	22218	92.2 3.63	25.4 1.00	193.8 7.63	173.0 6.81	46.0 1.81	47.8 1.88	124.0 4.88	36.6 1.44	257.0 10.12	65.8 2.59	107.2 4.22	158.8 6.25	46.0 1.81	20.0 44
QATU18A304S QAATU18A304S	3 1/4 in.															
QATU18A080S QAATU18A080S	80 mm															
QATU18A085S QAATU18A085S	85 mm															
QATU18A307S QAATU18A307S	3 7/16 in.															
QATU18A308S QAATU18A308S	3 1/2 in.															
QATU18A090S QAATU18A090S	90 mm															
QATU20A315S QAATU20A315S	3 15/16 in.															
QATU20A400S QAATU20A400S	4 in.															
QATU20A100S QAATU20A100S	100 mm															
QAATU22A110S	110 mm															
QAATU22A407S	4 7/16 in.	22222	128.5 5.06	38.1 1.50	263.7 10.38	241.3 9.50	54.1 2.13	54.1 2.13	162.1 6.38	-	341.4 13.44	79.5 3.13	143.8 5.66	199.9 7.87	52.3 2.06	36.4 80
QAATU22A408S	4 1/2 in.															
QAATU22A115S	115 mm															
QAATU26A125S	125 mm	22226	134.9 5.31	63.5 2.50	285.8 11.25	260.4 10.25	63.5 2.50	60.5 2.38	177.8 7.00	-	396.7 15.62	94.5 3.72	150.9 5.94	228.6 9.00	52.3 2.06	60.8 134
QAATU26A415S	4 15/16 in.															
QAATU26A500S	5 in.															
QAATU26A130S	130 mm															

⁽¹⁾Bearing part numbers use QA to designate single-collar units and QAA to designate double-collar units.

NOTE: Please refer to page 250 for take-up frames.

QATP AND QAATP TOP ANGLE TAKE-UP BLOCKS

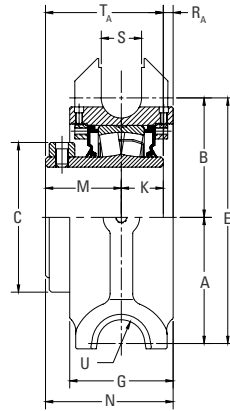
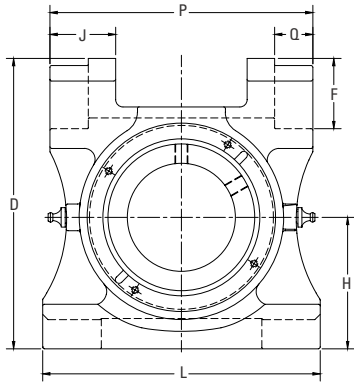

QATP

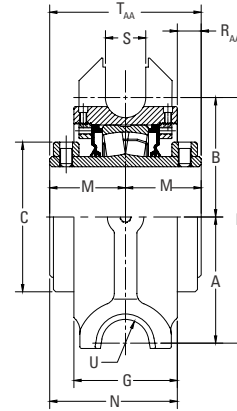

QAATP

Bearing Part No.	Shaft Dia.	Bearing No.	A	B	C	D	E	F	G	H	J	K	L	M	N	P	Q	R _A	R _{AA}	S	T _A	T _{AA}	U	
	mm in.		mm in.	mm in.	mm in.	mm in.	mm in.	mm in.	mm in.	mm in.	mm in.	mm in.	mm in.	mm in.	mm in.	mm in.	mm in.	mm in.	mm in.	mm in.	mm in.	mm in.	kg lbs.	
QATP10A115S QAATP10A115S	1 1/8 in.	22210	71.4	60.5	73.0	163.6	131.8	42.2	62.7	77.8	41.9	25.0	165.1	48.0	79.3	152.4	20.6	6.3	16.7	22.4	73.0	96.0	20.6	
QATP10A200S QAATP10A200S	2 in.		2.81	2.38	2.88	6.44	5.19	1.66	2.47	3.06	1.65	0.98	6.50	1.89	3.12	6.00	0.81	0.25	0.66	0.88	2.87	3.78	0.81	
QATP10A050S QAATP10A050S	50 mm																							
QATP11A203S QAATP11A203S	2 3/8 in.	22211	82.6	72.8	82.6	193.8	158.8	49.3	69.9	88.9	44.4	28.7	190.6	50.8	88.5	177.8	26.9	9.0	13.1	98.4	79.5	101.6	20.6	
QATP11A204S QAATP11A204S	2 1/4 in.		3.25	2.87	3.25	7.63	6.25	1.94	2.75	3.50	1.75	1.13	7.50	2.00	3.49	7.0	1.06	0.36	0.51	1.12	3.13	4.0	0.81	
QATP11A055S QAATP11A055S	55 mm																							
QATP13A207S QAATP13A207S	2 7/8 in.	22213	96.8	84.6	96.6	210.3	181.4	47.8	81.0	97.5	44.5	31.5	215.9	54.5	95.0	203.2	26.9	9.0	14.0	28.4	86.0	109.0	20.6	
QATP13A208S QAATP13A208S	2 1/2 in.		3.81	3.33	3.81	8.28	7.14	1.88	3.19	3.84	1.75	1.24	8.50	2.15	3.74	8.00	1.06	0.35	0.55	1.12	3.39	4.29	0.81	
QATP13A060S QAATP13A060S	60 mm																							
QATP15A211S QAATP15A211S	2 11/16 in.	22215	97.0	84.1	108.9	215.9	181.1	49.3	81.0	101.4	44.4	31.8	215.9	60.2	100.7	203.2	26.9	8.7	19.7	28.4	92.0	120.4	20.6	
QATP15A212S QAATP15A212S	2 3/4 in.		3.82	3.31	4.29	8.50	7.13	1.94	3.19	3.99	1.75	1.25	8.50	2.37	3.96	8.00	1.06	0.34	0.78	1.12	3.62	4.74	0.81	
QATP15A070S QAATP15A070S	70 mm																							
QATP15A215S QAATP15A215S	2 15/16 in.																							
QATP15A300S QAATP15A300S	3 in.																							
QATP15A075S QAATP15A075S	75 mm																							

QATP AND QAATP TOP ANGLE TAKE-UP BLOCKS

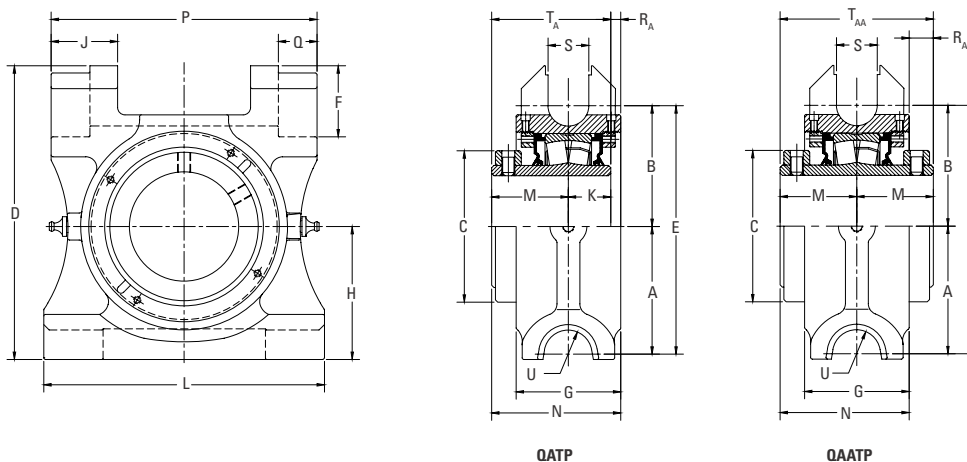

Bearing Part No.	Shaft Dia.	Bearing No.	A	B	C	D	E	F	G	H	J	K	L	M	N	P	Q	R _A	R _{AA}	S	T _A	T _{AA}	U
	mm in.		mm in.	mm in.	mm in.	mm in.	mm in.	mm in.	mm in.	mm in.	mm in.	mm in.	mm in.	mm in.	mm in.	mm in.	mm in.	mm in.	mm in.	mm in.	mm in.	mm in.	kg lbs.
QATP18A303S QAATP18A303S	3 3/8 in.	22218	109.7 4.32	103.9 4.09	130.2 5.13	252.5 9.94	213.6 8.41	61.3 2.41	90.0 3.54	114.3 4.50	57.1 2.25	36.5 1.44	241.3 9.50	65.9 2.59	110.9 4.37	228.6 9.00	33.3 1.31	8.6 0.34	20.8 0.82	35.1 1.38	102.4 4.03	131.8 5.19	20.6 0.81
QATP18A304S QAATP18A304S	3 1/4 in.																						
QATP18A080S QAATP18A080S	80 mm																						
QATP18A085S QAATP18A085S	85 mm																						
QATP18A307S QAATP18A307S	3 7/8 in.																						
QATP18A308S QAATP18A308S	3 1/2 in.																						
QATP18A090S QAATP18A090S	90 mm																						
QATP20A311S QAATP20A311S	3 11/16 in.																						
QATP20A312S QAATP20A312S	3 3/4 in.																						
QATP20A315S QAATP20A315S	3 15/16 in.																						
QATP20A400S QAATP20A400S	4 in.																						
QATP20A100S QAATP20A100S	100 mm																						

QAMH AND QAAMH HANGER BLOCKS

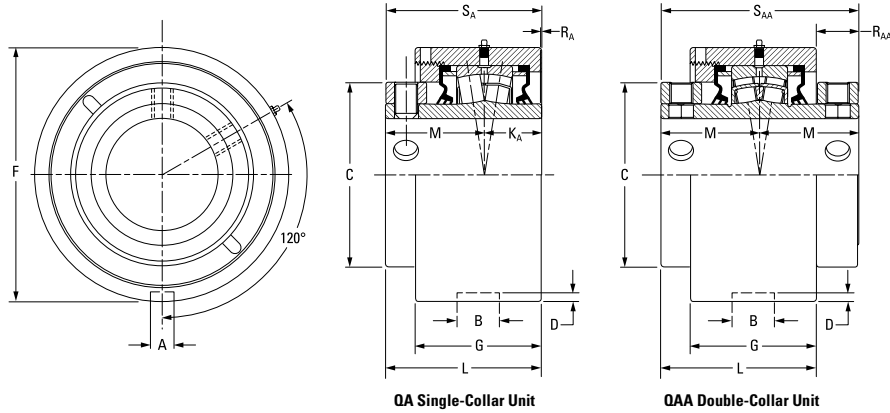

Bearing Part No.	Shaft Dia.	Bearing No.	A	B	C	D	E	F	G	J	K _A	L	M	R _A	R _{AA}	S _A	S _{AA}	Wt.
	mm in.		mm in.	mm in.	mm in.	mm in.	mm in.	mm in.	mm in.	in.	mm in.	mm in.	mm in.	mm in.	mm in.	mm in.	mm in.	kg lbs.
QAMH15A211S QAAMH15A211S	2 1/16 in.	22215	131.8 5.19	212.9 8.38	109.0 4.29	162.1 6.38	50.8 2.00	50.8 2.00	69.9 2.75	1 - 8UNC	31.8 1.25	91.9 3.62	60.2 2.37	0.0 0.00	28.4 1.12	91.9 3.62	120.7 4.75	10.0 22
QAMH15A212S QAAMH15A212S	2 3/4 in.																	
QAMH15A070S QAAMH15A070S	70 mm																	
QAMH15A215S QAAMH15A215S	2 15/16 in.																	
QAMH15A300S QAAMH15A300S	3 in.																	
QAMH15A075S QAAMH15A075S	75 mm																	
QAMH18A303S QAAMH18A303S	3 3/16 in.	22218	160.3 6.31	260.4 10.25	130.3 5.13	200.2 7.88	63.5 2.50	76.2 3.00	76.2 3.00	1 1/4 - 7UNC	36.6 1.44	99.3 3.91	65.8 2.59	3.0 0.12	32.3 1.27	102.4 4.03	131.6 5.18	16.3 36
QAMH18A304S QAAMH18A304S	3 1/4 in.																	
QAMH18A080S QAAMH18A080S	80 mm																	
QAMH18A085S QAAMH18A085S	85 mm																	
QAMH18A307S QAAMH18A307S	3 7/16 in.																	
QAMH18A308S QAAMH18A308S	3 1/2 in.																	
QAMH18A090S QAAMH18A090S	90 mm																	



EC SERIES

The reduced eccentric offset of our EC series locking collar results in a secure shaft lock that is designed not to release from a properly prepared shaft. EC series mounted bearings also are suitable for reversing applications.

The following topics are covered within this section:

Introduction	180
QMP Two-Bolt Pillow Blocks	181
QMPL Two-Bolt Pillow Blocks	182
QMPMD Two-Bolt Pillow Blocks	183
QMPF Four-Bolt Pillow Blocks	184
QMPR Four-Bolt Pillow Blocks	185
QMPH and QMPG Four-Bolt Pillow Blocks	186
QMPX 5000 Series Four-Bolt Pillow Blocks	187
QMPXT 5000 Series Two-Bolt Pillow Blocks	189
QMSN SN-Style Two-Bolt Pillow Blocks	190
QMC Piloted Flange Cartridges	192
QMCMD Piloted Flange Cartridges	193
QMCW Piloted Flange Cartridges	194
QMF Four-Bolt Square Flange Blocks	196
QMFL Four-Bolt Square Flange Blocks	197
QMFMD Four-Bolt Square Flange Blocks	198
QMFY Round Flange Blocks	199
QMFY 5000 Series Square Flange Blocks	201
QMMC Cartridge Blocks	203
QMTU Take-Up Blocks	205
QMTTP Top Angle Take-Up Blocks	206
QMMH Hanger Blocks	207

EC SERIES

Fig. 49. EC series eccentric lock.

YOU HAVE CHOICES

For the EC series, you can select from many seal configurations and housing styles, which are shown on page 15.

HOUSINGS

- Two-bolt pillow blocks
- Four-bolt pillow blocks
- Flange blocks
- Piloted flange cartridges
- Take-up blocks
- Cartridge blocks
- Hanger blocks

SEALS

- Labyrinth: DuPont™ Teflon® (T)
- Triple-lip: nitrile rubber (M), urethane (O) and Viton® (N)
- Double-lip: nitrile rubber (B) and Viton (C)
- Steel and urethane closed-end covers (CS)
- Steel and urethane open-end covers (CJ) with:
 - DuPont Teflon (T)
 - Triple-lip seal (DR)
 - V-ring seal (VR)
- Piloted flange cartridge backing plates (HSY) with:
 - Triple-lip seal (DR)
- Flange block backing plates (UFP)
 - V-ring (VR)

QMP TWO-BOLT PILLOW BLOCKS

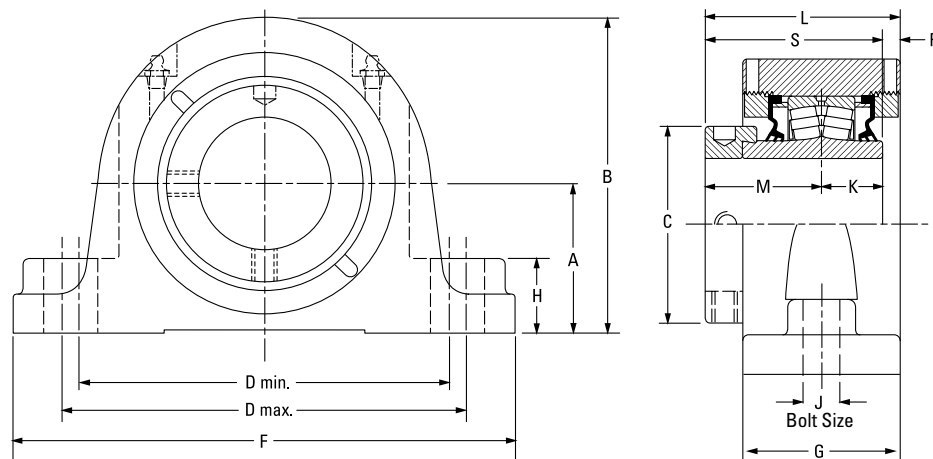

Bearing Part No.	Shaft Dia.	Bearing No.	A	B	C	D min.	D max.	F	G	H	J	K	L	M	R	S	Wt.	
	mm in.		mm in.	mm in.	mm in.	mm in.	mm in.	mm in.	mm in.	mm in.	mm in.	mm in.	mm in.	mm in.	mm in.	mm in.	kg lbs.	
QMP08J035S	35 mm	22208	47.8	94.7	60.5	119.1	152.4	174.8	57.2	25.4	12	25.4	73.2	44.5	3.3	69.9	4.1	
QMP08J107S	1 7/16 in.		1.88	3.73	2.38	4.69	6.00	6.88	2.25	1.00	1/2	1.00	2.88	1.75	0.13	2.75	9	
QMP08J108S	1 1/2 in.	22208	54.1	101.1	60.5	119.1	165.1	200.2	57.2	25.4	12	25.4	73.2	44.5	3.3	69.9	4.1	
			2.13	3.98	2.38	4.69	6.50	7.88	2.25	1.00	1/2	1.00	2.88	1.75	0.13	2.75	9	
QMP09J111S	1 1/8 in.	22209	54.1	104.9	66.5	144.8	165.1	200.2	60.2	31.8	12	25.4	77.7	47.8	4.8	73.2	4.5	
			2.13	4.13	2.62	5.70	6.50	7.88	2.37	1.25	1/2	1.00	3.06	1.88	0.19	2.88	10	
QMP09J040S	40 mm	22209	57.2	108.0	66.5	158.8	180.8	225.6	62.0	31.8	16	25.4	78.7	47.8	5.8	73.2	4.5	
QMP09J112S	1 3/4 in.		2.25	4.25	2.62	6.25	7.12	8.88	2.44	1.25	5/8	1.00	3.10	1.88	0.23	2.88	10	
QMP09J045S	45 mm																	
QMP10J115S	1 1/8 in.	22210	57.2	122.2	71.4	152.4	181.1	225.6	62.0	31.8	16	25.4	79.0	47.5	6.1	72.9	5.9	
QMP10J200S	2 in.		2.25	4.81	2.81	6.00	7.13	8.88	2.44	1.25	5/8	1.00	3.11	1.87	0.24	2.87	13	
QMP10J050S	50 mm																	
QMP11J203S	2 3/8 in.	22211	63.5	133.4	75.9	165.1	200.2	244.6	66.8	31.8	16	28.7	84.1	50.8	4.8	79.5	7.7	
QMP11J204S	2 1/2 in.		2.50	5.25	2.99	6.50	7.88	9.63	2.63	1.25	5/8	1.13	3.31	2.00	0.19	3.13	17	
QMP11J055S	55 mm																	
QMP13J060S	60 mm	22213	69.9	147.3	91.9	174.8	219.2	260.4	73.7	35.1	16	31.5	91.2	54.1	5.3	85.6	10.0	
QMP13J207S	2 3/8 in.		2.75	5.80	3.62	6.88	8.63	10.25	2.90	1.38	5/8	1.24	3.59	2.13	0.21	3.37	22	
QMP13J208S	2 1/2 in.																	
QMP13J065S	65 mm	22215	79.5	164.3	101.9	200.2	244.6	295.4	76.2	35.1	20	31.8	98.3	60.2	6.4	91.9	12.7	
QMP15J211S	2 1/8 in.																	
QMP15J212S	2 3/8 in.		3.13	6.47	4.01	7.88	9.63	11.63	3.00	1.38	3/4	1.25	3.87	2.37	0.25	3.62	28	
QMP15J070S	70 mm																	
QMP15J215S	2 15/16 in.																	
QMP15J300S	3 in.																	
QMP15J075S	75 mm																	
QMP18J303S	3 3/8 in.	22218	95.3	195.3	120.9	238.3	285.8	342.9	86.6	47.8	24	36.6	109.2	65.8	7.1	102.4	20.4	
QMP18J304S	3 1/4 in.		3.75	7.69	4.76	9.38	11.25	13.50	3.41	1.88	7/8	1.44	4.30	2.59	0.28	4.03	45	
QMP18J080S	80 mm																	
QMP18J085S	85 mm																	
QMP18J307S	3 7/8 in.																	
QMP18J308S	3 1/2 in.																	
QMP18J090S	90 mm																	
QMP20J311S	3 1/8 in.	22220	104.9	209.8	152.4	255.0	320.0	362.0	94.7	50.8	24	41.4	122.9	75.2	6.1	116.6	26.8	
QMP20J312S	3 3/8 in.		4.13	8.26	6.00	10.04	12.60	14.25	3.73	2.00	1	1.63	4.84	2.96	0.24	4.59	59	
QMP20J315S	3 15/16 in.																	
QMP20J400S	4 in.																	
QMP20J100S	100 mm																	

QMPL TWO-BOLT PILLOW BLOCKS

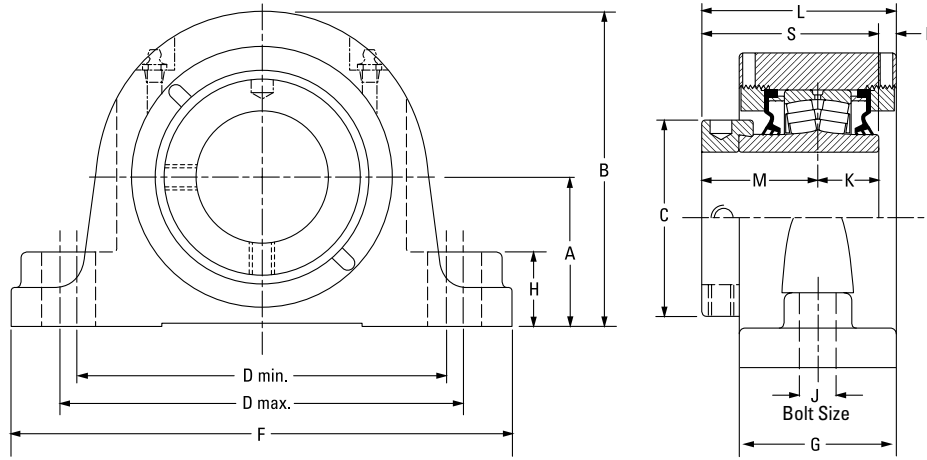

Bearing Part No.	Shaft Dia.	Bearing No.	A	B	C	D min.	D max.	F	G	H	J	K	L	M	R	S	Wt.
	mm in.		mm in.	mm in.	mm in.	mm in.	mm in.	mm in.	mm in.	mm in.	mm in.	mm in.	mm in.	mm in.	mm in.	mm in.	kg lbs.
QMPL08J035S	35 mm	22208	47.8	94.7	60.5	119.1	152.4	174.8	57.2	25.4	12	25.4	73.2	44.5	3.3	69.9	4.1
QMPL08J107S	1 7/16 in.		1.88	3.73	2.38	4.69	6.00	6.88	2.25	1.00	1/2	1.00	2.88	1.75	0.13	2.75	9
QMPL08J108S	1 1/2 in.																
QMPL09J040S	40 mm	22209	54.1	104.9	66.5	133.4	146.1	181.1	60.2	31.8	12	25.4	77.7	47.8	4.8	73.2	4.5
QMPL09J111S	1 1/16 in.		2.13	4.13	2.62	5.25	5.75	7.13	2.37	1.25	1/2	1.00	3.06	1.88	0.19	2.88	10
QMPL09J112S	1 3/4 in.																
QMPL09J045S	45 mm	22210	57.2	122.2	71.4	150.6	161.5	212.9	62.0	31.8	16	25.4	79.0	47.5	6.1	72.9	5.9
QMPL10J115S	1 15/16 in.		2.25	4.81	2.81	5.93	6.36	8.38	2.44	1.25	3/8	1.00	3.11	1.87	0.24	2.87	13
QMPL10J200S	2 in.																
QMPL10J050S	50 mm	22211	63.5	133.4	75.9	165.1	179.3	225.6	65.5	31.8	16	28.4	83.3	50.8	4.3	79.2	7.7
QMPL11J203S	2 3/16 in.		2.50	5.25	2.99	6.50	7.06	8.88	2.58	1.25	5/8	1.12	3.28	2.00	0.17	3.12	17
QMPL11J204S	2 1/4 in.																
QMPL11J055S	55 mm	22213	69.9	147.3	91.9	173.0	189.0	235.0	73.7	35.1	16	31.5	90.9	54.1	5.3	85.6	10.0
QMPL13J060S	60 mm		2.75	5.80	3.62	6.81	7.44	9.25	2.90	1.38	5/8	1.24	3.58	2.13	0.21	3.37	22
QMPL13J207S	2 7/16 in.																
QMPL13J208S	2 1/2 in.																
QMPL13J065S	65 mm	22215	82.6	167.4	101.9	195.6	213.4	265.2	76.2	35.1	20	31.8	98.3	60.2	6.4	91.9	12.7
QMPL15J211S	2 1/16 in.		3.25	6.59	4.01	7.70	8.40	10.44	3.00	1.38	3/4	1.25	3.87	2.37	0.25	3.62	28
QMPL15J212S	2 3/4 in.																
QMPL15J070S	70 mm	22218	95.3	195.3	120.9	235.0	273.1	330.2	86.6	47.8	24	36.6	109.2	65.8	7.1	102.4	20.4
QMPL15J215S	2 15/16 in.		3.75	7.69	4.76	9.25	10.75	13.00	3.41	1.88	7/8	1.44	4.30	2.59	0.28	4.03	45
QMPL15J300S	3 in.																
QMPL15J075S	75 mm	22220	108.0	212.9	152.4	255.0	320.0	362.0	94.7	53.8	24	41.4	122.9	75.2	6.1	116.6	26.8
QMPL18J303S	3 3/16 in.		4.25	8.38	6.00	10.04	12.60	14.25	3.73	2.12	1	1.63	4.84	2.96	0.24	4.59	59
QMPL18J304S	3 1/4 in.																
QMPL18J080S	80 mm																
QMPL18J085S	85 mm																
QMPL18J307S	3 7/16 in.																
QMPL18J308S	3 1/2 in.																
QMPL18J090S	90 mm																
QMPL20J311S	3 1/16 in.																
QMPL20J312S	3 3/4 in.																
QMPL20J315S	3 15/16 in.																
QMPL20J400S	4 in.																
QMPL20J100S	100 mm																

QMPMD TWO-BOLT PILLOW BLOCKS

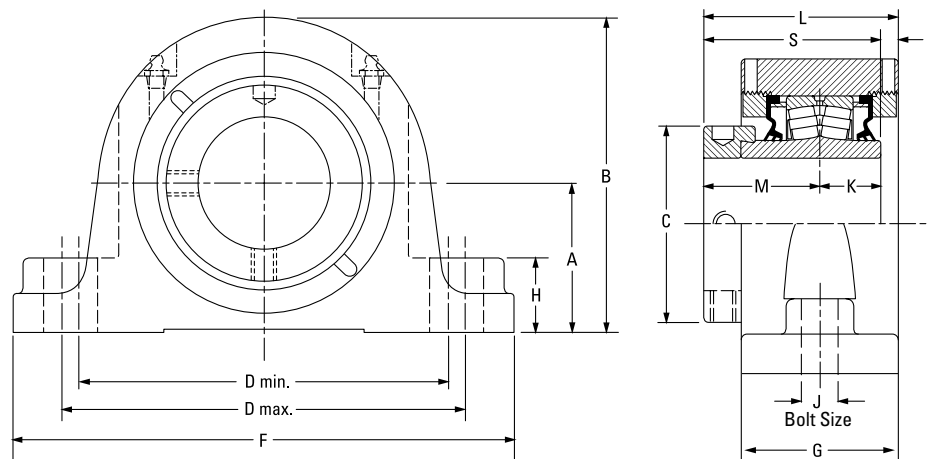

Bearing Part No.	Shaft Dia.	Bearing No.	A	B	C	D min.	D max.	F	G	H	J	K	L	M	R	S	Wt.
	mm in.		mm in.	mm in.	mm in.	mm in.	mm in.	mm in.	mm in.	mm in.	mm in.	mm in.	mm in.	mm in.	mm in.	mm in.	kg lbs.
QMPMD08J035S	35 mm	22208	54.1	110.5	60.5	131.6	149.4	184.2	57.2	25.4	12	25.4	73.2	44.5	3.3	69.9	4.1
QMPMD08J107S	1 7/16 in.		2.13	4.35	2.38	5.18	5.88	7.25	2.25	1.00	1/2	1.00	2.88	1.75	0.13	2.75	9
QMPMD08J108S	1 1/2 in.	22208	54.1	100.8	60.0	119.1	165.1	189.0	57.2	25.4	12	25.4	75.4	44.5	3.2	69.9	4.1
QMPMD09J040S	40 mm	22209	54.1	113.3	66.8	139.7	157.2	189.0	62.0	25.4	12	25.4	78.7	47.8	5.6	73.2	4.5
QMPMD09J111S	1 1/16 in.		2.13	4.46	2.63	5.5	6.19	7.44	2.44	1.00	1/2	1.00	3.10	1.88	0.22	2.88	10
QMPMD09J112S	1 3/8 in.	22209	57.2	116.3	66.8	152.4	169.7	206.2	62.0	31.8	16	25.4	78.7	47.8	5.6	73.2	4.5
QMPMD09J045S	45 mm		2.25	4.58	2.63	6.00	6.68	8.12	2.44	1.25	5/8	1.00	3.10	1.88	0.22	2.88	10
QMPMD10J115S	1 15/16 in.	22210	63.5	127.2	71.4	162.1	189.0	225.6	62.0	31.8	16	25.4	79.0	47.5	6.1	72.9	5.9
QMPMD10J200S	2 in.		2.50	5.00	2.81	6.38	7.44	8.88	2.44	1.25	5/8	1.00	3.11	1.87	0.24	2.87	13
QMPMD10J050S	50 mm	22211	69.9	139.7	82.6	174.8	201.7	241.3	66.8	38.1	16	28.7	84.3	50.8	4.8	79.2	7.7
QMPMD11J203S	2 3/8 in.		2.75	5.50	3.25	6.88	7.94	9.50	2.63	1.50	5/8	1.13	3.32	2.00	0.19	3.13	17
QMPMD11J204S	2 1/4 in.	22213	76.2	153.7	92.0	190.5	223.0	273.1	73.7	34.9	20	31.5	91.4	54.6	5.3	86.0	10.0
QMPMD11J055S	55 mm		3.00	6.05	3.62	7.50	8.78	10.75	2.90	1.38	3/4	1.24	3.60	2.15	0.21	3.39	22
QMPMD13J060S	60 mm	22215	88.9	171.5	109.0	215.9	241.3	298.5	76.2	38.1	24	31.8	98.3	60.2	6.4	91.9	12.7
QMPMD13J207S	2 7/16 in.		3.50	6.75	4.29	8.50	9.50	11.75	3.00	1.50	7/8	1.25	3.87	2.37	0.25	3.62	28
QMPMD13J208S	2 1/2 in.	22218	101.6	201.7	121.0	262.1	295.1	344.9	85.9	28.4	24	36.6	109.2	65.8	6.35	102.4	20.4
QMPMD13J065S	65 mm		4.00	7.94	4.76	10.32	11.62	13.58	3.38	1.12	7/8	1.44	4.30	2.59	0.25	4.03	45
QMPMD15J211S	2 1/16 in.	22218	101.6	201.7	121.0	262.1	295.1	344.9	85.9	28.4	24	36.6	109.2	65.8	6.35	102.4	20.4
QMPMD15J212S	2 3/8 in.		4.00	7.94	4.76	10.32	11.62	13.58	3.38	1.12	7/8	1.44	4.30	2.59	0.25	4.03	45
QMPMD15J070S	70 mm	22218	101.6	201.7	121.0	262.1	295.1	344.9	85.9	28.4	24	36.6	109.2	65.8	6.35	102.4	20.4
QMPMD15J215S	2 15/16 in.		4.00	7.94	4.76	10.32	11.62	13.58	3.38	1.12	7/8	1.44	4.30	2.59	0.25	4.03	45
QMPMD15J300S	3 in.	22218	101.6	201.7	121.0	262.1	295.1	344.9	85.9	28.4	24	36.6	109.2	65.8	6.35	102.4	20.4
QMPMD15J075S	75 mm		4.00	7.94	4.76	10.32	11.62	13.58	3.38	1.12	7/8	1.44	4.30	2.59	0.25	4.03	45
QMPMD18J303S	3 3/16 in.	22218	101.6	201.7	121.0	262.1	295.1	344.9	85.9	28.4	24	36.6	109.2	65.8	6.35	102.4	20.4
QMPMD18J304S	3 1/4 in.		4.00	7.94	4.76	10.32	11.62	13.58	3.38	1.12	7/8	1.44	4.30	2.59	0.25	4.03	45
QMPMD18J080S	80 mm	22218	101.6	201.7	121.0	262.1	295.1	344.9	85.9	28.4	24	36.6	109.2	65.8	6.35	102.4	20.4
QMPMD18J085S	85 mm		4.00	7.94	4.76	10.32	11.62	13.58	3.38	1.12	7/8	1.44	4.30	2.59	0.25	4.03	45
QMPMD18J307S	3 7/16 in.	22218	101.6	201.7	121.0	262.1	295.1	344.9	85.9	28.4	24	36.6	109.2	65.8	6.35	102.4	20.4
QMPMD18J308S	3 1/2 in.		4.00	7.94	4.76	10.32	11.62	13.58	3.38	1.12	7/8	1.44	4.30	2.59	0.25	4.03	45
QMPMD18J090S	90 mm	22218	101.6	201.7	121.0	262.1	295.1	344.9	85.9	28.4	24	36.6	109.2	65.8	6.35	102.4	20.4

QMPF FOUR-BOLT PILLOW BLOCKS

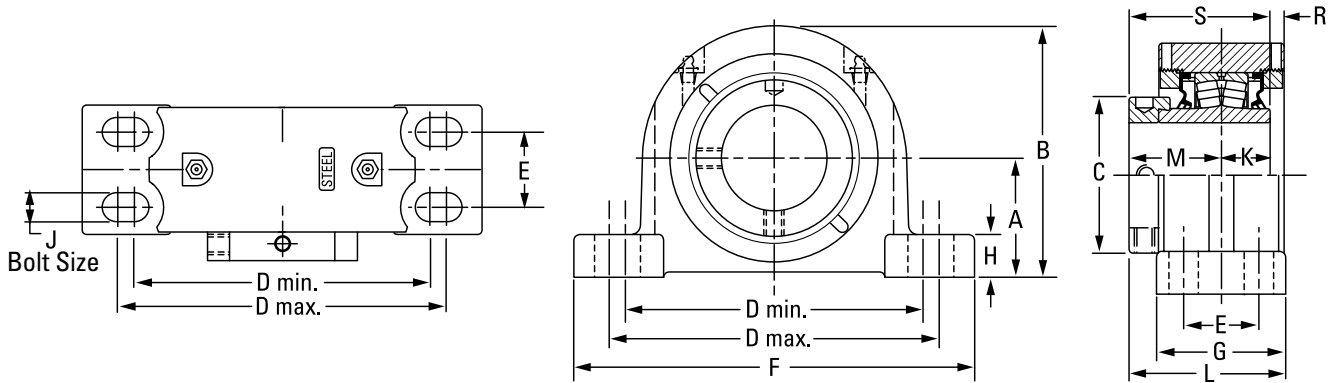

Bearing Part No.	Shaft Dia.	Bearing No.	A	B	C	D min.	D max.	E	F	G	H	J	K	L	M	R	S	Wt.
	mm in.		mm in.	mm in.	mm in.	mm in.	mm in.	mm in.	mm in.	mm in.	mm in.	mm in.	mm in.	mm in.	mm in.	mm in.	mm in.	kg lbs.
QMPF13J060S	60 mm	22213	69.9 2.75	147.3 5.80	91.9 3.62	174.8 6.88	193.8 7.63	44.5 1.75	235.0 9.25	76.2 3.00	24.9 0.98	16 5/8	31.5 1.24	92.2 3.63	54.1 2.13	5.3 0.21	85.6 3.37	9.1 20
QMPF13J207S	2 7/8 in.																	
QMPF13J208S	2 1/2 in.																	
QMPF13J065S	65 mm	22215	82.6 3.25	167.6 6.60	101.9 4.01	193.0 7.60	231.1 9.10	47.8 1.88	265.2 10.44	79.5 3.13	32.8 1.29	16 5/8	31.8 1.25	99.8 3.93	60.2 2.37	6.1 0.24	91.9 3.62	12.2 27
QMPF15J211S	2 1/4 in.																	
QMPF15J212S	2 3/4 in.																	
QMPF15J070S	70 mm	22218	95.3 3.75	195.3 7.69	120.9 4.76	225.6 8.88	276.4 10.88	50.8 2.00	312.4 12.30	95.3 3.75	39.6 1.56	20 3/4	36.6 1.44	113.3 4.46	65.8 2.59	8.1 0.32	102.4 4.03	22.2 49
QMPF15J215S	2 15/16 in.																	
QMPF15J300S	3 in.																	
QMPF15J075S	75 mm	22220	108.0 4.25	223.0 8.78	152.4 6.00	276.4 10.88	339.9 13.38	57.2 2.25	378.0 14.88	109.5 4.31	35.6 1.40	20 3/4	41.4 1.63	130.3 5.13	75.2 2.96	9.1 0.36	116.6 4.59	30.4 67
QMPF18J303S	3 3/8 in.																	
QMPF18J304S	3 1/4 in.																	
QMPF18J080S	80 mm	22222	120.7 4.75	233.4 9.19	160.0 6.30	301.8 11.88	368.3 14.50	63.5 2.50	409.7 16.13	120.7 4.75	40.1 1.58	20 3/4	46.5 1.83	154.4 6.08	94.0 3.70	4.3 0.17	140.5 5.53	37.2 82
QMPF18J085S	85 mm																	
QMPF18J307S	3 7/8 in.																	
QMPF18J308S	3 1/2 in.	22226	139.7 5.50	279.7 11.01	175.0 6.89	349.3 13.75	403.4 15.88	69.9 2.75	444.5 17.5	128.0 5.04	39.1 1.54	24 7/8	58.7 2.31	158.8 6.25	94.7 3.73	-0.8 -0.03	153.4 6.04	60.8 134
QMPF20J311S	3 11/16 in.																	
QMPF20J312S	3 3/4 in.																	
QMPF20J315S	3 15/16 in.	23230	169.9 6.69	330.2 13.00	205.0 8.07	441.5 17.38	485.9 19.13	95.3 3.75	558.8 22.00	171.5 6.75	76.2 3.00	24 1	75.9 2.99	201.7 7.94	116.1 4.57	6.6 0.26	192.0 7.56	113.4 250
QMPF20J400S	4 in.																	
QMPF20J100S	100 mm																	
QMPF22J110S	110 mm	23234	190.5 7.50	390.7 15.38	235.0 9.25	530.4 20.88	600.2 23.63	117.5 4.625	660.4 26.00	190.5 7.50	63.5 2.50	24 1	85.1 3.35	224.3 8.83	129.0 5.08	5.6 0.22	214.1 8.43	170.1 375
QMPF22J407S	4 7/8 in.																	
QMPF22J408S	4 1/2 in.																	
QMPF22J115S	115 mm	23234	190.5 7.50	390.7 15.38	235.0 9.25	530.4 20.88	600.2 23.63	117.5 4.625	660.4 26.00	190.5 7.50	63.5 2.50	24 1	85.1 3.35	224.3 8.83	129.0 5.08	5.6 0.22	214.1 8.43	170.1 375
QMPF26J125S	125 mm																	
QMPF26J415S	4 15/16 in.																	
QMPF26J500S	5 in.	23234	190.5 7.50	390.7 15.38	235.0 9.25	530.4 20.88	600.2 23.63	117.5 4.625	660.4 26.00	190.5 7.50	63.5 2.50	24 1	85.1 3.35	224.3 8.83	129.0 5.08	5.6 0.22	214.1 8.43	170.1 375
QMPF26J130S	130 mm																	
QMPF30J507S	5 7/8 in.																	
QMPF30J508S	5 1/2 in.	23234	190.5 7.50	390.7 15.38	235.0 9.25	530.4 20.88	600.2 23.63	117.5 4.625	660.4 26.00	190.5 7.50	63.5 2.50	24 1	85.1 3.35	224.3 8.83	129.0 5.08	5.6 0.22	214.1 8.43	170.1 375
QMPF30J140S	140 mm																	
QMPF30J515S	5 15/16 in.																	
QMPF30J600S	6 in.	23234	190.5 7.50	390.7 15.38	235.0 9.25	530.4 20.88	600.2 23.63	117.5 4.625	660.4 26.00	190.5 7.50	63.5 2.50	24 1	85.1 3.35	224.3 8.83	129.0 5.08	5.6 0.22	214.1 8.43	170.1 375
QMPF30J150S	150 mm																	
QMPF34J607S	6 7/8 in.																	
QMPF34J608S	6 1/2 in.	23234	190.5 7.50	390.7 15.38	235.0 9.25	530.4 20.88	600.2 23.63	117.5 4.625	660.4 26.00	190.5 7.50	63.5 2.50	24 1	85.1 3.35	224.3 8.83	129.0 5.08	5.6 0.22	214.1 8.43	170.1 375
QMPF34J170S	170 mm																	
QMPF34J615S	6 15/16 in.																	
QMPF34J700S	7 in.	23234	190.5 7.50	390.7 15.38	235.0 9.25	530.4 20.88	600.2 23.63	117.5 4.625	660.4 26.00	190.5 7.50	63.5 2.50	24 1	85.1 3.35	224.3 8.83	129.0 5.08	5.6 0.22	214.1 8.43	170.1 375
QMPF34J180S	180 mm																	

QMPR FOUR-BOLT PILLOW BLOCKS

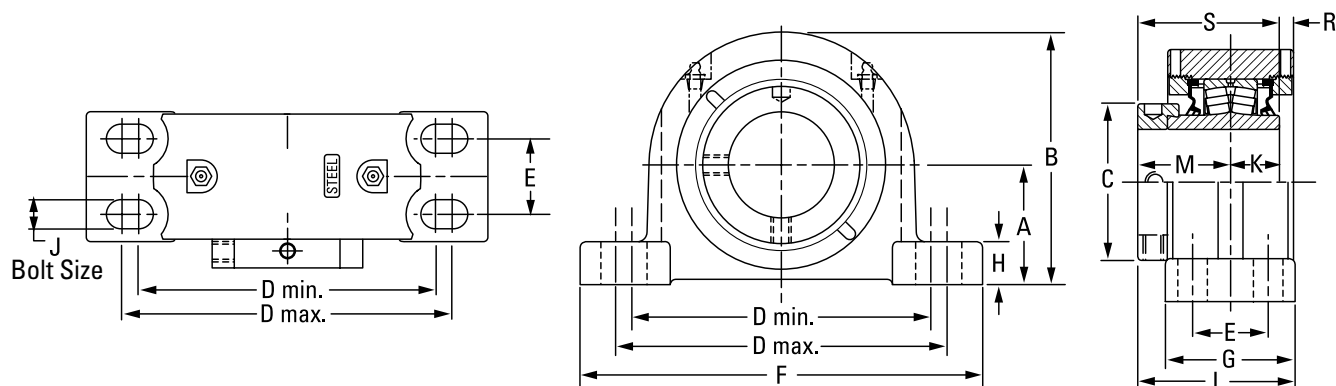

Bearing Part No.	Shaft Dia.	Bearing No.	A	B	C	D min.	D max.	E	F	G	H	J	K	L	M	R	S	Wt.
	mm in.		mm in.	mm in.	mm in.	mm in.	mm in.	mm in.	mm in.	mm in.	mm in.	mm in.	mm in.	mm in.	mm in.	mm in.	mm in.	kg lbs.
QMPR13J060S	60 mm	22213	69.9 2.75	147.3 5.80	91.9 3.62	181.1 7.13	222.3 8.75	47.8 1.88	260.4 10.25	82.6 3.25	24.9 0.98	16 5/8	31.5 1.24	95.5 3.76	54.1 2.13	5.3 0.21	85.6 3.37	9.1 20
QMPR13J207S	2 7/16 in.																	
QMPR13J208S	2 1/2 in.																	
QMPR13J065S	65 mm																	
QMPR15J211S	2 11/16 in.	22215	79.5 3.13	164.3 6.47	101.9 4.01	203.2 8.00	243.8 9.60	54.1 2.13	275.1 10.83	85.9 3.38	29.5 1.16	16 5/8	31.8 1.25	103.1 4.06	60.2 2.37	6.1 0.24	91.9 3.62	12.2 27
QMPR15J212S	2 3/4 in.																	
QMPR15J070S	70 mm																	
QMPR15J215S	2 15/16 in.																	
QMPR15J300S	3 in.	22218	95.3 3.75	195.3 7.69	120.9 4.76	235.0 9.25	285.8 11.25	60.5 2.38	346.2 13.63	95.3 3.75	39.6 1.56	20 3/4	36.6 1.44	113.3 4.46	65.8 2.59	8.1 0.32	102.4 4.03	22.2 49
QMPR15J075S	75 mm																	
QMPR18J303S	3 3/16 in.																	
QMPR18J304S	3 1/4 in.																	
QMPR18J080S	80 mm	22220	108.0 4.25	223.0 8.78	152.4 6.00	276.4 10.88	339.9 13.38	57.2 2.25	378.0 14.88	109.5 4.31	35.6 1.40	20 3/4	41.4 1.63	130.3 5.13	75.2 2.96	8.9 0.35	116.7 4.59	30.4 69
QMPR18J085S	85 mm																	
QMPR18J307S	3 7/16 in.																	
QMPR18J308S	3 1/2 in.																	
QMPR18J090S	90 mm	22222	120.7 4.75	233.4 9.19	160.0 6.30	301.8 11.88	368.3 14.50	63.5 2.50	409.7 16.13	120.7 4.75	40.1 1.58	20 3/4	46.5 1.83	154.4 6.08	94.0 3.70	4.3 0.17	140.5 5.53	37.2 82
QMPR20J311S	3 11/16 in.																	
QMPR20J312S	3 3/4 in.																	
QMPR20J315S	3 15/16 in.																	
QMPR20J400S	4 in.	22226	139.7 5.50	179.7 11.014	175.0 6.89	330.2 13.00	403.4 15.88	71.4 2.81	444.5 17.50	128.0 5.04	39.1 1.54	24 7/8	58.7 2.31	158.5 6.24	94.5 3.72	-1.0 -0.04	153.2 6.03	60.8 134
QMPR20J100S	100 mm																	
QMPR22J110S	110 mm																	
QMPR22J407S	4 7/16 in.																	
QMPR22J408S	4 1/2 in.																	
QMPR22J115S	115 mm																	
QMPR26J125S	125 mm																	
QMPR26J415S	4 15/16 in.																	
QMPR26J500S	5 in.																	
QMPR26J130S	130 mm																	

QMPH AND QMPG FOUR-BOLT PILLOW BLOCKS

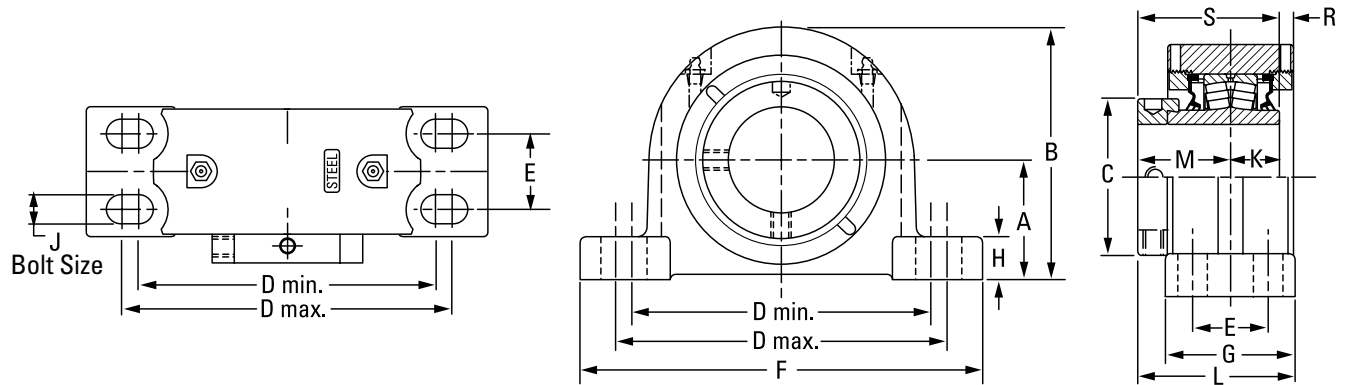

QMPH SAF STYLE FOUR-BOLT PILLOW BLOCK DIMENSIONS

Bearing Part No.	Shaft Dia.	Bearing No.	A	B	C	D min.	D max.	E	F	G	H	J	K	L	M	R	S	Wt.
	mm in.		mm in.	mm in.	mm in.	mm in.	mm in.	mm in.	mm in.	mm in.	mm in.	mm in.	mm in.	mm in.	mm in.	mm in.	mm in.	kg lbs.
QMPH26J125S	125 mm	22226	152.4 6.00	290.8 11.45	175 6.89	406.4 16.00	435.1 17.13	85.9 3.38	500.4 19.70	128 5.04	51.8 2.04	24 1	58.7 2.31	158.5 6.24	94.5 3.72	-0.7 -0.03	153.4 6.04	60.8
QMPH26J415S	4 1/16 in.																	134
QMPH26J500S	5 in.																	134
QMPH26J130S	130 mm	23230	169.9 6.69	330.7 13.02	205.0 8.07	441.5 17.38	485.9 19.13	95.3 3.75	558.8 22.00	171.5 6.75	76.2 3.00	24 1	75.9 2.99	199.1 7.84	116.1 4.57	5.1 0.20	192.0 7.56	118.8
QMPH30J507S	5 7/16 in.																	262
QMPH30J508S	5 1/2 in.																	262
QMPH30J140S	140 mm	23230	179.4 7.06	339.9 13.38	205.0 8.07	492.3 19.38	549.4 21.63	108.0 4.25	628.7 24.75	171.5 6.75	85.9 3.38	24 1	75.9 2.99	201.7 7.94	116.1 4.57	6.6 0.26	192.0 7.56	122.9
QMPH30J515S	5 15/16 in.																	271
QMPH30J600S	6 in.																	271
QMPH30J150S	150 mm	23234	190.5 7.50	390.7 15.38	235.0 9.25	530.4 20.88	600.2 23.63	117.5 4.63	711.2 28.00	190.5 7.50	63.5 2.50	24 1	85.1 3.35	224.3 8.83	129.0 5.08	5.6 0.22	214.1 8.43	170.1
QMPH34J607S	6 7/16 in.																	375
QMPH34J608S	6 1/2 in.																	375
QMPH34J170S	170 mm	23234	200.0 7.88	400.1 15.75	235.0 9.25	549.4 21.63	619.3 24.38	112.7 4.44	711.2 28.00	190.5 7.50	73.2 2.88	30 1 1/4	85.1 3.35	224.3 8.83	129.0 5.08	5.6 0.22	214.1 8.43	178.3
QMPH34J615S	6 15/16 in.																	393
QMPH34J700S	7 in.																	393
QMPH34J180S	180 mm																	

QMPG SN STYLE FOUR-BOLT PILLOW BLOCK DIMENSIONS

Bearing Part No.	Shaft Dia.	Bearing No.	A	B	C	D min.	D max.	E	F	G	H	J	K	L	M	R	S	Wt.
	mm in.		mm in.	mm in.	mm in.	mm in.	mm in.	mm in.	mm in.	mm in.	mm in.	mm in.	mm in.	mm in.	mm in.	mm in.	mm in.	kg lbs.
QMPG26J125S	125 mm	22226	150.0 5.91	288.4 11.36	175.0 6.89	383.4 15.09	448.5 17.66	80.0 3.15	500.1 19.69	128 5.04	49.3 1.94	24 1	58.7 2.31	158.5 6.24	94.5 3.72	-6.9 -0.27	153.4 6.04	60.8
QMPG26J415S	4 1/16 in.																	134
QMPG26J500S	5 in.																	134
QMPG26J130S	130 mm	23230	170.0 6.69	332.2 13.08	205.0 8.07	438.2 17.25	482.6 19.00	89.9 3.54	547.6 21.65	171.5 6.75	76.2 3.00	24 1	75.9 2.99	198.6 7.82	116.1 4.57	9.7 0.38	192.0 7.56	113.4
QMPG30J507S	5 7/16 in.																	250
QMPG30J508S	5 1/2 in.																	250
QMPG30J140S	140 mm	23234	190.5 7.50	390.7 15.38	235.0 9.25	530.4 20.88	600.2 23.63	117.5 4.63	711.2 28.00	190.5 7.50	63.5 2.50	24 1	85.1 3.35	224.3 8.83	129.0 5.08	5.6 0.22	214.1 8.43	178.3
QMPG30J600S	6 in.																	393
QMPG30J150S	150 mm																	393
QMPG34J607S	6 7/16 in.	23234	200.0 7.88	400.1 15.75	235.0 9.25	549.4 21.63	619.3 24.38	114.3 4.50	711.2 28.00	190.5 7.50	73.2 2.88	30 1 1/4	85.1 3.35	224.3 8.83	129.0 5.08	5.6 0.22	214.1 8.43	170.1
QMPG34J608S	6 1/2 in.																	375
QMPG34J170S	170 mm																	375
QMPG34J615S	6 15/16 in.	23234	200.0 7.88	400.1 15.75	235.0 9.25	549.4 21.63	619.3 24.38	114.3 4.50	711.2 28.00	190.5 7.50	73.2 2.88	30 1 1/4	85.1 3.35	224.3 8.83	129.0 5.08	5.6 0.22	214.1 8.43	170.1
QMPG34J700S	7 in.																	375
QMPG34J180S	180 mm																	375

QMPX 5000 SERIES FOUR-BOLT PILLOW BLOCKS

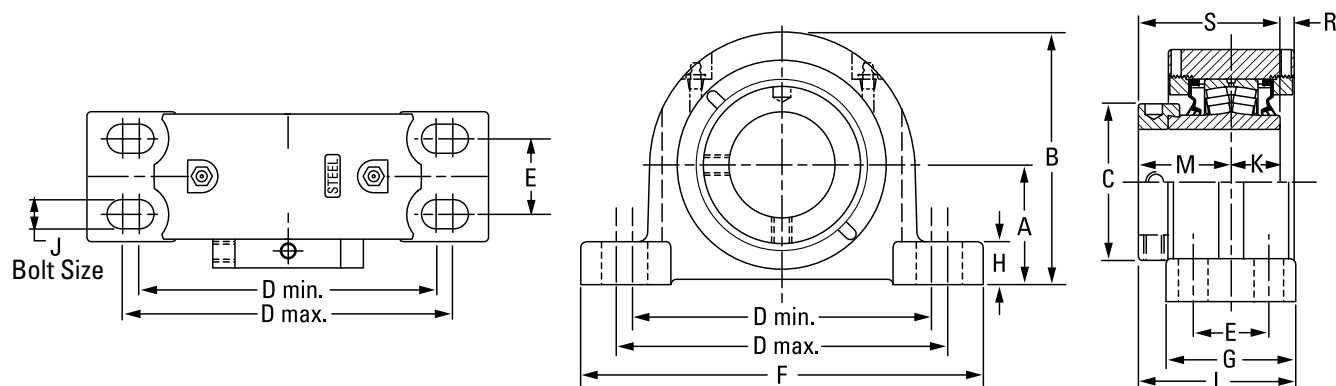

Bearing Part No.	Shaft Dia.	Bearing No.	A	B	C	D min.	D max.	E	F	G	H	J	K	L	M	R	S	Wt.
	mm in.		mm in.	mm in.	mm in.	mm in.	mm in.	mm in.	mm in.	mm in.	mm in.	mm in.	mm in.	mm in.	mm in.	mm in.	mm in.	kg lbs.
QMPX13J060S	60 mm	22213	76.2 3.00	153.7 6.05	91.9 3.62	176.3 6.94	242.8 9.56	66.8 2.63	285.8 11.25	98.6 3.88	31.2 1.23	16 5/8	31.5 1.24	103.4 4.07	54.1 2.13	5.3 0.21	85.6 3.37	10.4 23
QMPX13J207S	2 7/16 in.																	
QMPX13J208S	2 1/2 in.																	
QMPX13J065S	65 mm	22215	88.9 3.50	173.5 6.83	101.9 4.01	230.1 9.06	265.2 10.44	68.9 2.75	330.2 13.00	108.0 4.25	39.1 1.54	20 3/4	31.8 1.25	114.3 4.50	60.2 2.37	7.1 0.28	91.9 3.62	12.7 28
QMPX15J211S	2 1/4 in.																	
QMPX15J212S	2 3/4 in.																	
QMPX15J070S	70 mm	22218	101.6 4.00	201.2 7.92	120.9 4.76	274.6 10.81	309.6 12.19	76.2 3.00	381.0 15.00	120.7 4.75	38.1 1.50	20 3/4	36.6 1.44	126.0 4.96	65.8 2.59	8.1 0.32	102.4 4.03	22.2 49
QMPX15J215S	2 15/16 in.																	
QMPX15J300S	3 in.																	
QMPX15J075S	75 mm	22220	127.0 5.00	239.8 9.44	152.4 6.00	317.5 12.50	355.6 14.00	88.9 3.50	425.5 16.75	139.7 5.50	41.4 1.63	24 7/8	41.4 1.63	145.3 5.72	75.2 2.96	8.6 0.34	116.6 4.59	30.4 67
QMPX18J303S	3 3/16 in.																	
QMPX18J304S	3 1/4 in.																	
QMPX18J080S	80 mm	22222	146.1 5.75	273.8 10.78	160.0 6.30	354.1 13.94	395.2 15.56	101.6 4.00	469.9 18.50	158.8 6.25	45.7 1.80	24 1	46.5 1.83	171.2 6.74	94.0 3.70	2.3 0.09	140.5 5.53	37.2 82
QMPX18J085S	85 mm																	
QMPX18J307S	3 7/16 in.																	
QMPX18J308S	3 1/2 in.																	
QMPX18J090S	90 mm																	
QMPX20J311S	3 1/16 in.																	
QMPX20J312S	3 3/4 in.																	
QMPX20J315S	3 15/16 in.																	
QMPX20J400S	4 in.																	
QMPX20J100S	100 mm																	
QMPX22J110S	110 mm																	
QMPX22J407S	4 7/16 in.																	
QMPX22J408S	4 1/2 in.																	
QMPX22J115S	115 mm																	

⁽¹⁾No gussets on outside housing.

Continued on next page.

QMPX 5000 SERIES FOUR-BOLT PILLOW BLOCKS – *continued*

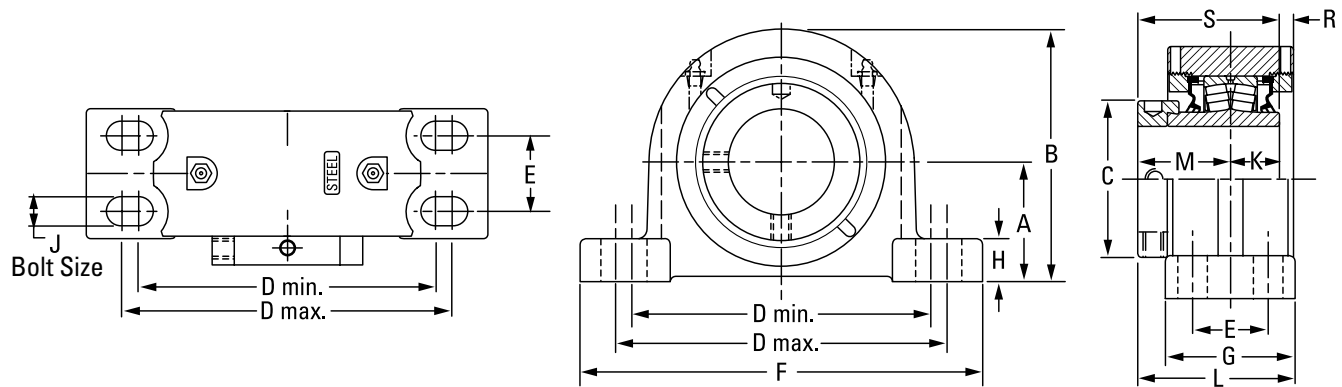

Continued from previous page.

Bearing Part No.	Shaft Dia.	Bearing No.	A	B	C	D min.	D max.	E	F	G	H	J	K	L	M	R	S	Wt.	
	mm in.		mm in.	mm in.	mm in.	mm in.	mm in.	mm in.	mm in.	mm in.	mm in.	mm in.	mm in.	mm in.	mm in.	mm in.	mm in.	kg lbs.	
QMPX26J125S	125 mm	22226	155.6 6.13	283.2 11.15	175.0 6.89	387.4 15.25	425.5 16.75	108.0 4.25	514.4 20.25	171.5 6.75	50.8 2.00	24 1 1/8	58.7 2.31	180.3 7.10	94.5 3.72	-1.5 -0.06	153.4 6.04	60.8 134	
QMPX26J415S	4 15/16 in.																		
QMPX26J500S	5 in.																		
QMPX26J130S	130 mm	23230	169.9 6.69	330.2 13.00	205.0 8.07	439.9 17.32	485.8 19.125	93.5 3.68	558.8 22.00	171.5 6.75	76.2 3.00	24 1 1/8	75.9 2.99	201.7 7.94	116.1 4.57	6.6 0.26	192.0 7.56	113.4 250	
QMPX30J507S	5 7/16 in.																		
QMPX30J508S	5 1/2 in.																		
QMPX30J140S	140 mm	23230	179.4 7.06	339.9 13.38	205.0 8.07	489.0 19.25	552.5 21.75	106.4 4.19	625.7 24.75	171.5 6.75	85.6 3.37	24 1 1/8	75.9 2.99	196.9 7.75	116.1 4.57	4.8 0.19	192.0 7.56	120.2 265	
QMPX30J515S ⁽¹⁾	5 15/16 in.																		
QMPX30J600S ⁽¹⁾	6 in.																		
QMPX30J150S ⁽¹⁾	150 mm	23234	200.0 7.88	400.1 15.75	235.0 9.25	549.4 21.63	619.3 24.38	112.8 4.44	711.2 28.00	190.5 7.50	73.2 2.88	30 1 1/4	80.1 3.35	224.3 8.83	129.0 5.08	5.6 0.22	214.1 8.43	179.2 395	
QMPX34J607S ⁽¹⁾	6 7/16 in.																		
QMPX34J608S ⁽¹⁾	6 1/2 in.																		
QMPX34J170S ⁽¹⁾	170 mm																		
QMPX34J615S ⁽¹⁾	6 15/16 in.																		
QMPX34J700S ⁽¹⁾	7 in.																		
QMPX34J180S ⁽¹⁾	180 mm																		

⁽¹⁾No gussets on outside housing.

QMPXT 5000 SERIES TWO-BOLT PILLOW BLOCKS

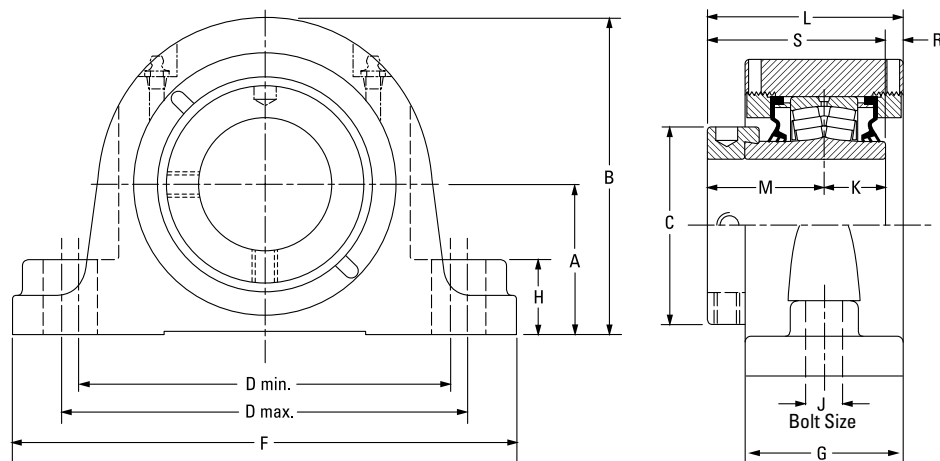

Bearing Part No.	Shaft Dia.	Bearing No.	A	B	C	D min.	D max.	F	G	H	J	K	L	M	R	S	Wt.
	mm in.		mm in.	mm in.	mm in.	mm in.	mm in.	mm in.	mm in.	mm in.	mm in.	mm in.	mm in.	mm in.	mm in.	mm in.	kg lbs.
QMPXT13J060S	60 mm	22213	76.2 3.00	153.7 6.05	91.9 3.62	194.6 7.66	223.0 8.78	285.8 11.25	73.7 2.90	35.1 1.38	20 ¾	31.5 1.24	91.4 3.60	54.1 2.13	5.3 0.21	85.6 3.37	10.0 22
QMPXT13J207S	2 ¼ in.																
QMPXT13J208S	2 ½ in.																
QMPXT13J065S	65 mm																
QMPXT15J211S	2 ¼ in.	22215	88.9 3.50	173.7 6.84	101.9 4.01	230.1 9.06	265.2 10.44	330.2 13.00	75.7 2.98	35.1 1.38	24 7/8	31.8 1.25	98.0 3.86	60.2 2.37	6.1 0.24	91.9 3.62	12.7 28
QMPXT15J212S	2 ¾ in.																
QMPXT15J070S	70 mm																
QMPXT15J215S	2 ⅝ in.																
QMPXT15J300S	3 in.																
QMPXT15J075S	75 mm																

QMSN SN-STYLE TWO-BOLT PILLOW BLOCKS – PURE METRIC DESIGN

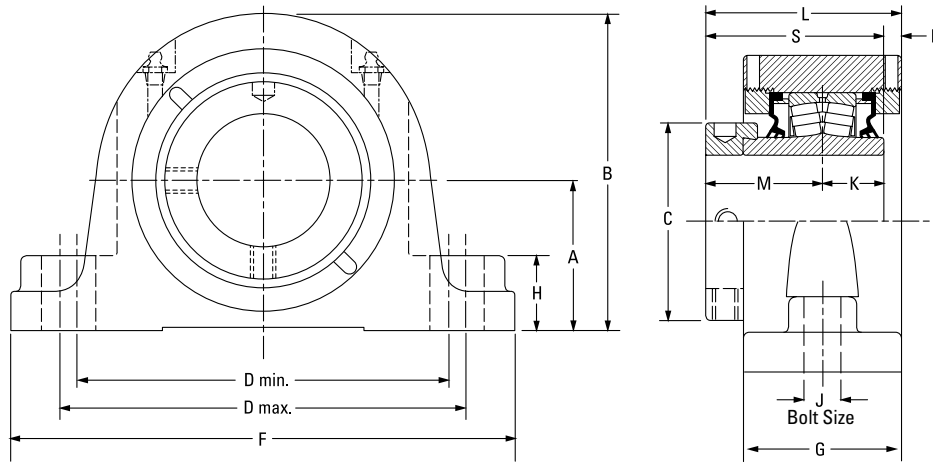

Bearing Part No.	Shaft Dia.	Bearing No.	A	B	C	D min.	D max.	F	G	H	J	K	L	M	R	S	Wt.
	mm in.		mm in.	mm in.	mm in.	mm in.	mm in.	mm in.	mm in.	mm in.	mm in.	mm in.	mm in.	mm in.	mm in.	mm in.	kg lbs.
QMSN08J035S	35 mm																
QMSN08J107S	1 7/16 in.	22208	60 2.36	111 4.37	60.5 2.38	159 6.26	175 6.89	205 8.07	62 2.44	35 1.38	12 1/2	25 1.00	75 2.95	44 1.75	5 0.20	70 2.75	10.5 23
QMSN08J108S	1 1/2 in.																
QMSN09J040S	40 mm																
QMSN09J111S	1 11/16 in.	22209	60 2.36	111 4.37	67 2.64	159 6.26	175 6.89	205 8.07	62 2.44	35 1.38	12 1/2	25 0.98	79 3.11	48 1.89	6 0.24	73 2.87	10.5 23
QMSN09J112S	1 3/4 in.																
QMSN09J045S	45 mm																
QMSN10J115S	1 15/16 in.	22210	70 2.76	136 5.35	70 2.76	183 7.20	216 8.50	254 10.00	68 2.68	25 0.98	16 5/8	25 0.98	82 3.23	48 1.89	9 0.35	73 2.87	12.7 28
QMSN10J200S	2 in.																
QMSN10J050S	50 mm																
QMSN11J203S	2 3/16 in.	22211	70 2.76	141 5.55	76 2.99	183 7.20	216 8.50	254 10.00	68 2.68	25 0.98	16 5/8	29 1.14	85 3.35	51 2.01	6 0.24	80 3.15	13.2 29
QMSN11J204S	2 1/4 in.																
QMSN11J055S	55 mm																
QMSN13J060S	60 mm																
QMSN13J207S	2 7/16 in.	22213	80 3.15	157 6.18	92 3.62	196 7.72	235 9.25	275 10.83	74 2.91	35 1.38	16 5/8	31 1.22	91 3.58	55 2.17	5 0.20	86 3.39	15.9 35
QMSN13J208S	2 1/2 in.																
QMSN13J065S	65 mm																
QMSN15J211S	2 11/16 in.	22215	95 3.74	183 7.20	102 4.02	241 9.49	279 10.98	316 12.44	76 2.99	34 1.34	20 3/4	32 1.26	98 3.86	60 2.36	6 0.24	92 3.62	20.9 46
QMSN15J212S	2 3/4 in.																
QMSN15J070S	70 mm																
QMSN15J215S	2 15/16 in.																
QMSN15J300S	3 in.																
QMSN15J075S	75 mm																
QMSN18J303S	3 3/16 in.	22218	100 3.94	200 7.87	121 4.76	279 10.98	292 11.50	345 13.58	86 3.39	39 1.54	20 3/4	37 1.46	109 4.29	66 2.60	7 0.28	103 4.06	25.5 56
QMSN18J304S	3 1/4 in.																
QMSN18J080S	80 mm																

QMSN SN-STYLE TWO-BOLT PILLOW BLOCKS – PURE METRIC DESIGN

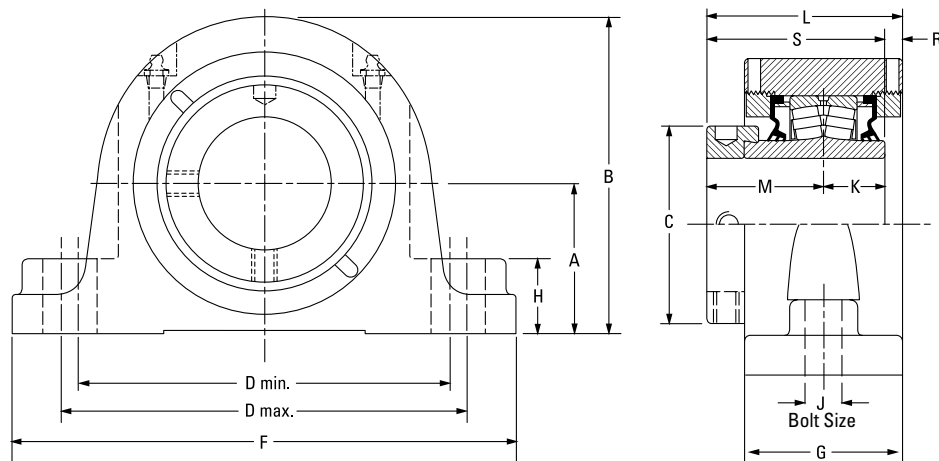

Bearing Part No.	Shaft Dia.	Bearing No.	A	B	C	D min.	D max.	F	G	H	J	K	L	M	R	S	Wt.
	mm in.		mm in.	mm in.	mm in.	mm in.	mm in.	mm in.	mm in.	mm in.	mm in.	mm in.	mm in.	mm in.	mm in.	mm in.	kg lbs.
QMSN18J085S	85 mm	22218	112 4.41	212 8.35	121 4.76	280 11.02	292 11.50	345 13.58	86 3.38	39 1.53	20 3/4	37 1.46	109 4.29	66 2.60	7 0.28	103 4.06	25.5 56
QMSN18J307S	3 7/16 in.	22218	112 4.41	212 8.35	121 4.76	290 11.42	327 12.87	380 14.96	86 3.38	39 1.53	24 7/8	37 1.46	109 4.29	66 2.60	7 0.28	103 4.06	25.5 56
QMSN18J308S	3 1/2 in.																
QMSN18J090S	90 mm																
QMSN20J311S	3 11/16 in.	22220	125 4.92	241 9.48	152 5.98	319 12.58	366 14.42	410 16.14	101 3.96	50 1.98	24 7/8	41 1.61	126 4.96	75 2.95	9 0.35	116 4.57	35.9 79
QMSN20J312S	3 3/4 in.																
QMSN20J315S	3 15/16 in.																
QMSN20J400S	4 in.																
QMSN20J100S	100 mm																
QMSN22J110S	110 mm	22222	140 5.51	255 10.04	160 6.30	332 13.08	365 14.37	410 16.14	105 4.15	39 1.53	24 7/8	47 1.85	147 5.79	94 3.70	6 0.24	141 5.55	35.9 79
QMSN22J407S	4 7/16 in.	22222	150 5.91	265 10.43	160 6.30	367 14.45	400 15.75	445 17.52	105 4.13	49 1.93	24 7/8	47 1.85	147 5.79	94 3.70	6 0.24	141 5.55	35.5 78
QMSN22J408S	4 1/2 in.																
QMSN22J115S	115 mm																
QMSN26J125S	125 mm	22226	150 5.91	282 11.10	175 6.89	402 15.83	435 17.13	500 19.69	113 4.45	49 1.93	30 1 1/4	58 2.28	151 5.94	95 3.74	2 0.08	153 6.02	40.0 88
QMSN26J415S	4 15/16 in.																
QMSN26J500S	5 in.																
QMSN26J130S	130 mm	23230	170 6.69	330 13.01	205 8.07	461 18.15	479 18.86	550 21.65	171 6.75	76 3.01	30 1 1/4	76 2.99	202 7.94	116 4.57	7 0.26	192 7.56	136.4 300
QMSN30J507S	5 7/16 in.																
QMSN30J508S	5 1/2 in.																
QMSN30J140S	140 mm																
QMSN30J515S	5 15/16 in.																
QMSN30J600S	6 in.																
QMSN30J150S	150 mm																

QMC PILOTED FLANGE CARTRIDGES

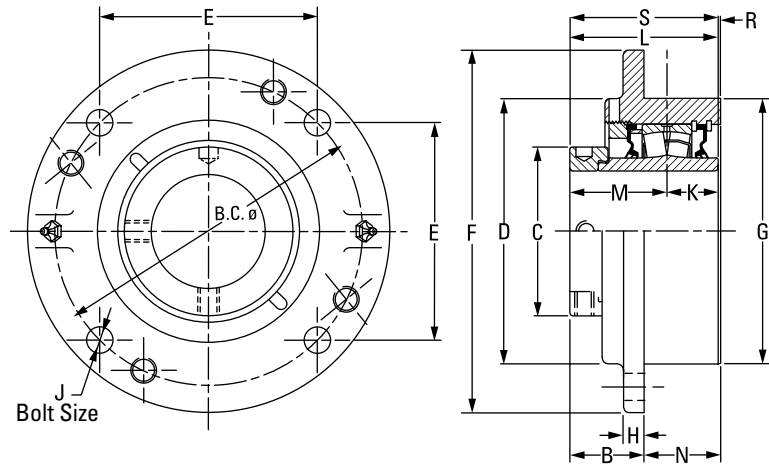

Bearing Part No.	Shaft Dia.	Bearing No.	B	B	B.C.	C	D	E	F	G ⁽¹⁾	H	J	K	L	L	M	N	R	S	Wt.	
			FIX	EXP	mm	mm	mm	mm	mm	mm	mm	mm	mm	mm	mm	mm	mm	mm	mm		mm
	mm in.		mm in.	mm in.	mm in.	mm in.	mm in.	mm in.	mm in.	mm in.	mm in.	mm in.	mm in.	mm in.	mm in.	mm in.	mm in.	mm in.	mm in.	mm in.	lbs.
QMC08J035S	35 mm																				
QMC08J107S	1 7/16 in.	22208	49.8	51.8	111.3	60.5	92.2	78.5	133.4	92.1	12.7	10	25.4	73.7	75.7	44.5	23.9	3.81	69.9	3.6	
QMC08J108S	1 1/2 in.		1.96	2.04	4.38	2.38	3.63	3.09	5.25	3.625	0.50	7/16	1.00	2.90	2.98	1.75	0.94	0.15	2.75	8	
QMC09J040S	40 mm																				
QMC09J111S	1 11/16 in.	22209	54.6	56.6	130.3	66.8	111.3	91.9	155.7	108.0	12.7	10	25.4	77.0	79.0	47.5	22.4	3.81	72.9	4.1	
QMC09J112S	1 3/4 in.		2.15	2.23	5.13	2.63	4.38	3.62	6.13	4.250	0.50	7/16	1.00	3.03	3.11	1.87	0.88	0.15	2.87	9	
QMC09J045S	45 mm																				
QMC10J115S	1 5/16 in.	22210	50.4	52.6	136.7	70.1	113.5	96.5	162.1	114.3	16.0	10	25.4	77.5	79.5	47.5	26.9	4.6	72.9	4.5	
QMC10J200S	2 in.		1.99	2.07	5.38	2.76	4.47	3.80	6.38	4.500	0.63	7/16	1.00	3.05	3.13	1.87	1.06	0.18	2.87	10	
QMC10J050S	50 mm																				
QMC11J203S	2 3/16 in.	22211	54.4	56.4	152.4	75.9	127.0	107.7	185.4	127.0	14.7	12	28.7	83.1	85.1	50.5	28.7	3.6	79.2	5.9	
QMC11J204S	2 1/4 in.		2.14	2.22	6.00	2.99	5.00	4.24	7.30	5.000	0.58	1/2	1.13	3.27	3.35	1.99	1.13	0.14	3.12	13	
QMC11J055S	55 mm																				
QMC13J060S	60 mm																				
QMC13J207S	2 7/16 in.	22213	59.4	61.5	165.1	91.9	139.7	116.8	193.8	139.7	17.5	12	31.5	87.9	91.2	54.1	28.7	2.3	85.6	7.3	
QMC13J208S	2 1/2 in.		2.34	2.42	6.50	3.62	5.50	4.60	7.63	5.500	0.69	1/2	1.24	3.46	3.59	2.13	1.13	0.09	3.37	16	
QMC13J065S	65 mm																				
QMC15J211S	2 11/16 in.	22215	62.5	64.5	190.5	101.9	159.2	134.6	222.3	161.9	20.6	16	31.8	94.5	96.5	60.2	31.8	2.3	91.9	10.0	
QMC15J212S	2 3/4 in.		2.46	2.54	7.50	4.01	6.27	5.30	8.75	6.375	0.81	5/8	1.25	3.72	3.80	2.37	1.25	0.09	3.62	22	
QMC15J070S	70 mm																				
QMC15J215S	2 5/8 in.																				
QMC15J300S	3 in.																				
QMC15J075S	75 mm																				
QMC18J303S	3 3/16 in.	22218	73.2	75.2	219.2	120.9	187.5	154.9	262.6	187.3	25.4	20	36.6	106.4	108.5	65.8	33.3	4.1	116.6	14.5	
QMC18J304S	3 1/4 in.		2.88	2.96	8.63	4.76	7.38	6.10	10.34	7.375	1.00	3/4	1.44	4.19	4.27	2.59	1.31	0.16	4.59	32	
QMC18J080S	80 mm																				
QMC18J085S	85 mm																				
QMC18J307S	3 7/16 in.																				
QMC18J308S	3 1/2 in.																				
QMC18J090S	90 mm																				
QMC20J311S	3 11/16 in.	22220	72.1	74.2	238.3	152.4	206.5	168.4	276.4	206.4	25.4	20	41.4	126.0	128.0	75.2	54.1	9.4	116.6	19.5	
QMC20J312S	3 3/4 in.		2.84	2.92	9.38	6.00	8.13	6.63	10.88	8.125	1.00	3/4	1.63	4.96	5.04	2.96	2.13	0.37	4.59	43	
QMC20J315S	3 5/8 in.																				
QMC20J400S	4 in.																				
QMC20J100S	100 mm																				
QMC22J110S ⁽²⁾	110 mm	22222	92.5	94.5	298.5	160.0	254.0	149.4	342.9	260.4	25.4	20	46.5	140.7	142.7	94.0	48.3	0.3	140.5	32.7	
QMC22J407S ⁽²⁾	4 7/16 in.		3.64	3.72	11.75 ⁽²⁾	6.30	10.00	5.88 ⁽²⁾	13.50	10.250	1.00	3/4 ⁽²⁾	1.83	5.54	5.62	3.70	1.90	0.01	5.53	72	
QMC22J408S ⁽²⁾	4 1/2 in.																				
QMC22J115S ⁽²⁾	115 mm																				

⁽¹⁾Pilot tolerance: +0/-0.05 mm (+0/-0.002 in.).

⁽²⁾Six-bolt housing.

QMCMD PILOTED FLANGE CARTRIDGES

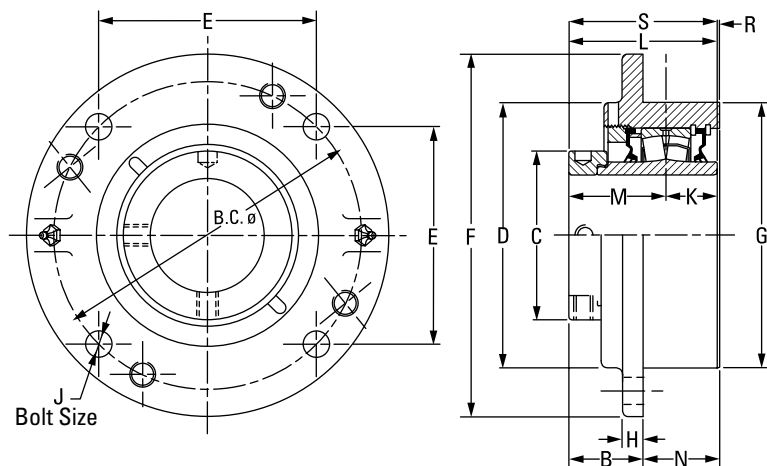

Bearing Part No.	Shaft Dia.	Bearing No.	B FIX	B EXP	B.C.	C	D	E	F	G ⁽¹⁾	H	J	K	L FIX	L EXP	M	N	R	S	Wt.
			mm in.	mm in.	mm in.	mm in.	mm in.	mm in.	mm in.	mm in.	mm in.	mm in.	mm in.	mm in.	mm in.	mm in.	mm in.	mm in.	mm in.	mm in.
QMCMD08J035S	35 mm	22208	49.8	51.8	111.3	60.5	92.2	78.5	133.4	92.1	12.7	10	25.4	73.7	75.7	44.5	23.9	4.06	69.9	3.6
QMCMD08J107S	1 7/16 in.		1.96	2.04	4.38	2.38	3.63	3.09	5.25	3.625	0.30	7/16	1.00	2.70	1.73	0.92	0.92	0.14	2.73	6
QMCMD08J108S	1 1/2 in.																			
QMCMD09J040S	40 mm	22209	54.6	56.3	130.3	65.0	111.3	91.9	155.7	108.0	12.7	12	25.4	77.0	79.0	47.5	22.4	4.10	73.2	4.1
QMCMD09J111S	1 1/16 in.		2.15	2.23	5.13	2.56	4.38	3.62	6.13	4.250	0.50	1/2	1.00	3.03	3.11	1.87	0.88	0.16	2.88	9
QMCMD09J112S	1 3/4 in.																			
QMCMD09J045S	45 mm	22210	50.1	52.6	136.7	70.3	113.5	96.5	162.1	114.3	16.0	12	25.4	77.5	79.5	47.5	26.9	4.6	72.9	4.5
QMCMD10J115S	1 1/16 in.		1.97	2.07	5.38	2.77	4.47	3.80	6.38	4.500	0.63	1/2	1.00	3.05	3.13	1.87	1.06	0.18	2.87	10
QMCMD10J200S	2 in.																			
QMCMD10J050S	50 mm	22211	54.0	56.4	152.4	75.3	127.0	107.7	185.4	127.0	14.7	12	28.7	82.7	85.1	50.5	28.7	3.5	79.2	5.9
QMCMD11J203S	2 3/16 in.		2.13	2.22	6.00	3.12	5.00	4.24	7.30	5.000	0.58	1/2	1.13	1.13	3.35	1.99	1.13	0.14	3.12	13
QMCMD11J204S	2 1/4 in.																			
QMCMD11J055S	55 mm	22213	60.5	61.5	165.1	96.8	139.7	116.8	193.8	139.7	17.5	12	31.5	88.9	91.2	54.1	28.7	2.3	85.6	7.3
QMCMD13J060S	60 mm		2.38	2.42	6.50	3.81	5.50	4.60	7.63	5.500	0.69	1/2	1.24	3.50	3.59	2.13	1.13	0.09	3.37	16
QMCMD13J207S	2 7/16 in.																			
QMCMD13J208S	2 1/2 in.																			
QMCMD13J065S	65 mm	22215	62.5	64.5	190.5	109.0	162.1	134.6	222.3	161.9	20.6	16	31.8	94.2	96.5	60.2	31.8	2.3	91.9	10.0
QMCMD15J211S	2 11/16 in.		2.46	2.54	7.50	4.29	6.38	5.30	8.75	6.375	0.81	5/8	1.25	3.71	3.80	2.37	1.25	0.09	3.62	22
QMCMD15J212S	2 3/4 in.																			
QMCMD15J070S	70 mm	22218	73.2	75.2	219.2	120.9	187.5	154.9	262.6	187.3	25.4	20	36.6	106.4	108.5	65.8	33.3	4.3	102.1	14.5
QMCMD15J300S	3 in.		2.88	2.96	8.63	4.76	7.38	6.10	10.34	7.375	1.00	3/4	1.44	4.19	4.27	2.59	1.31	0.17	4.02	32
QMCMD15J075S	75 mm																			
QMCMD18J303S	3 3/16 in.																			
QMCMD18J304S	3 1/4 in.																			
QMCMD18J080S	80 mm																			
QMCMD18J085S	85 mm																			
QMCMD18J307S	3 7/16 in.																			
QMCMD18J308S	3 1/2 in.																			
QMCMD18J090S	90 mm																			

⁽¹⁾Pilot tolerance: +0/-0.05 mm (+0/-0.002 in.).

QMCW PILOTED FLANGE CARTRIDGES

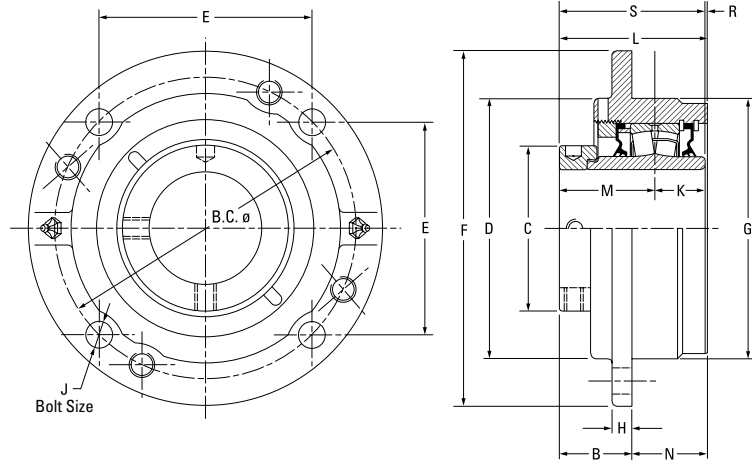

Bearing Part No.	Shaft Dia.	Bearing No.	B FIX	B EXP	B.C.	C	D	E	F	G ⁽¹⁾	H	J	K	L FIX	L EXP	M	N	R	S	Wt.
	mm in.		mm in.	mm in.	mm in.	mm in.	mm in.	mm in.	mm in.	mm in.	mm in.	mm in.	mm in.	mm in.	mm in.	mm in.	mm in.	mm in.	mm in.	kg lbs.
QMCW08J035S	35 mm	22208	38.6	40.9	111.3	59.9	92.2	78.5	133.4	92.1	12.7	10	25.4	73.7	75.7	44.5	35.1	3.8	69.9	3.6
QMCW08J107S	1 7/16 in.		1.53	1.61	4.38	2.36	3.63	3.09	5.25	3.625	0.50	7/16	1.00	2.90	2.98	1.75	1.38	0.15	2.75	8
QMCW08J108S	1 1/2 in.																			
QMCW09J040S	40 mm	22209	38.9	40.1	130.3	66.8	111.3	91.9	155.7	108.0	10.2	10	25.1	77.0	78.2	47.8	38.1	4.1	72.9	4.1
QMCW09J111S	1 1/16 in.		1.53	1.58	5.13	2.63	4.38	3.62	6.13	4.250	0.40	7/16	0.99	3.03	3.08	1.88	1.50	0.16	2.87	9
QMCW09J112S	1 3/4 in.																			
QMCW09J045S	45 mm	22210	39.1	41.1	136.7	71.4	113.5	96.5	162.1	114.3	9.7	10	24.9	77.2	79.2	48.0	38.1	4.3	72.9	4.5
QMCW10J115S	1 15/16 in.		1.54	1.62	5.38	2.81	4.47	3.80	6.38	4.500	0.38	7/16	0.98	3.04	3.12	1.89	1.50	0.17	2.87	10
QMCW10J200S	2 in.																			
QMCW10J050S	50 mm	22211	45.7	47.8	152.4	75.9	127.0	107.7	181.1	127.0	14.2	12	28.7	86.9	88.9	50.5	41.4	7.62	79.2	5.9
QMCW11J203S	2 3/16 in.		1.80	1.88	6.00	2.99	5.00	4.24	7.13	5.000	0.56	1/2	1.13	3.42	3.50	1.99	1.63	0.30	3.12	13
QMCW11J204S	2 1/4 in.																			
QMCW11J055S	55 mm	22213	47.5	49.5	165.1	91.9	139.7	116.8	193.8	139.7	12.7	12	31.5	90.2	92.2	54.1	42.9	4.31	85.6	7.3
QMCW13J060S	60 mm		1.87	1.95	6.50	3.62	5.50	4.60	7.63	5.500	0.50	1/2	1.24	3.55	3.63	2.13	1.69	0.17	3.37	16
QMCW13J207S	2 7/16 in.																			
QMCW13J208S	2 1/2 in.	22215	46.0	48.0	190.5	101.9	162.1	134.6	222.3	161.9	12.7	16	31.8	93.5	95.5	60.2	47.8	1.5	91.9	10.0
QMCW13J065S	65 mm		1.81	1.89	7.50	4.01	6.38	5.30	8.75	6.375	0.50	5/8	1.25	3.68	3.76	2.37	1.88	0.06	3.62	22
QMCW15J211S	2 1/16 in.																			
QMCW15J212S	2 3/4 in.	22218	62.5	64.5	219.2	120.9	187.5	154.9	260.4	187.3	22.4	20	36.6	110.2	112.3	65.8	47.8	7.9	102.4	14.5
QMCW15J070S	70 mm		2.15	2.15	8.63	4.76	7.38	6.10	10.25	7.375	0.88	3/4	1.44	4.34	4.42	2.59	1.88	0.31	4.03	32
QMCW15J215S	2 15/16 in.																			
QMCW15J300S	3 in.	22218	62.5	64.5	219.2	120.9	187.5	154.9	260.4	187.3	22.4	20	36.6	110.2	112.3	65.8	47.8	7.9	102.4	14.5
QMCW15J075S	75 mm		2.46	2.54	8.63	4.76	7.38	6.10	10.25	7.375	0.88	3/4	1.44	4.34	4.42	2.59	1.88	0.31	4.03	32
QMCW18J303S	3 3/16 in.																			
QMCW18J304S	3 1/4 in.	22218	62.5	64.5	219.2	120.9	187.5	154.9	260.4	187.3	22.4	20	36.6	110.2	112.3	65.8	47.8	7.9	102.4	14.5
QMCW18J080S	80 mm		2.46	2.54	8.63	4.76	7.38	6.10	10.25	7.375	0.88	3/4	1.44	4.34	4.42	2.59	1.88	0.31	4.03	32
QMCW18J085S	85 mm																			
QMCW18J307S	3 7/16 in.	22218	62.5	64.5	219.2	120.9	187.5	154.9	260.4	187.3	22.4	20	36.6	110.2	112.3	65.8	47.8	7.9	102.4	14.5
QMCW18J308S	3 1/2 in.		2.46	2.54	8.63	4.76	7.38	6.10	10.25	7.375	0.88	3/4	1.44	4.34	4.42	2.59	1.88	0.31	4.03	32
QMCW18J090S	90 mm																			

⁽¹⁾Pilot tolerance: +0/-0.05 mm (+0/-0.002 in.).

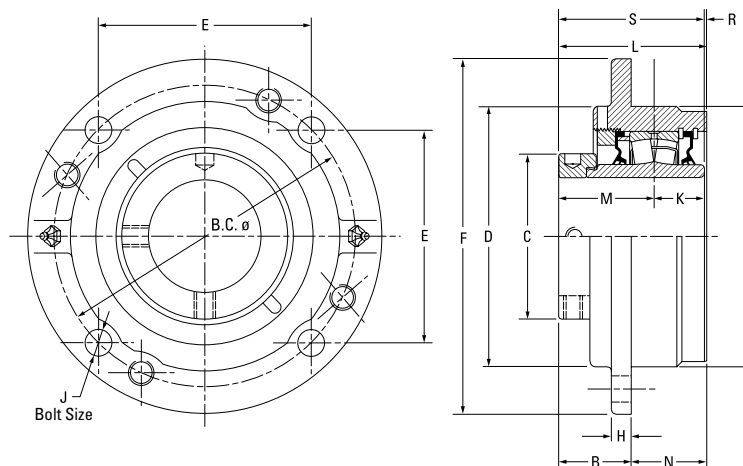

Bearing Part No.	Shaft Dia.	Bearing No.	B FIX	B EXP	B.C.	C	D	E	F	G ⁽¹⁾	H	J	K	L FIX	L EXP	M	N	R	S	Wt.	
			mm in.	mm in.	mm in.	mm in.	mm in.	mm in.	mm in.	mm in.	mm in.	mm in.	mm in.	mm in.	mm in.	mm in.	mm in.	mm in.	mm in.	mm in.	mm in.
QMCW20J311S	3 1/16 in.	22220	63.5 2.50	65.5 2.58	238.3 9.38	152.4 6.00	206.5 8.13	168.4 6.63	276.4 10.88	206.4 8.125	25.4 1.00	20 3/4	41.4 1.63	120.7 4.75	122.7 4.83	75.2 2.96	57.2 2.25	4.1 0.16	116.6 4.59	19.5 43	
QMCW20J312S	3 3/8 in.																				
QMCW20J315S	3 15/16 in.																				
QMCW20J400S	4 in.																				
QMCW20J100S	100 mm	22222	76.5 3.01	78.5 3.09	298.5 11.75 ⁽²⁾	160.0 6.30	254.0 10.00	149.4 5.88 ⁽²⁾	342.9 13.50	260.4 10.250	25.4 1.00	20 3/4 ⁽²⁾	46.5 1.83	144.8 5.70	146.8 5.78	94.0 3.70	68.3 2.69	4.3 0.17	140.5 5.53	32.7 72	
QMCW22J110S ⁽²⁾	110 mm																				
QMCW22J407S ⁽²⁾	4 7/16 in.																				
QMCW22J408S ⁽²⁾	4 1/2 in.																				
QMCW22J115S ⁽²⁾	115 mm	22226	73.7 2.90	75.7 2.98	323.9 12.75 ⁽²⁾	175.0 6.89	266.7 10.50	162.1 6.38 ⁽²⁾	374.7 14.75	279.4 11.000	26.2 1.03	24 7/8 ⁽²⁾	58.7 2.31	151.4 5.96	153.4 6.04	94.7 3.73	77.9 3.065	-1.8 -0.07	153.4 6.04	46.3 102	
QMCW26J125S ⁽²⁾	125 mm																				
QMCW26J415S ⁽²⁾	4 15/16 in.																				
QMCW26J500S ⁽²⁾	5 in.																				
QMCW26J130S ⁽²⁾	130 mm	23230	82.8 3.26	84.8 3.34	368.3 14.50 ⁽²⁾	205.0 8.07	304.8 12.00	184.2 7.25 ⁽²⁾	431.8 17.00	330.2 13.000	26.2 1.03	24 7/8 ⁽²⁾	75.9 2.99	204.2 8.04	206.2 8.12	116.1 4.57	121.4 4.78	12.2 0.48	192.0 7.56	102.5 226	
QMCW30J507S ⁽²⁾	5 7/16 in.																				
QMCW30J508S ⁽²⁾	5 1/2 in.																				
QMCW30J140S ⁽²⁾	140 mm																				
QMCW30J515S ⁽²⁾	5 15/16 in.	23230	82.8 3.26	84.8 3.34	419.1 16.50 ⁽²⁾	205.0 8.07	304.8 12.00	209.6 8.25 ⁽²⁾	482.6 19.00	355.6 14.000	26.2 1.03	24 7/8 ⁽²⁾	75.9 2.99	211.3 8.32	213.4 8.40	116.1 4.57	128.5 5.06	19.3 0.76	192.0 7.56	101.6 224	
QMCW30J600S ⁽²⁾	6 in.																				
QMCW30J150S ⁽²⁾	150 mm																				
QMCW34J607S ⁽²⁾	6 7/16 in.																				
QMCW34J608S ⁽²⁾	6 1/2 in.	23234	85.9 3.38	87.9 3.46	431.8 17.00	235.0 9.25	355.6 14.00	215.9 8.50	482.6 19.00	381.0 15.000	28.7 1.13	24 1 ⁽²⁾	85.1 3.35	216.2 8.51	218.2 8.59	129.0 5.08	130.3 5.13	2.0 0.08	214.1 8.43	152.4 336	
QMCW34J170S ⁽²⁾	170 mm																				
QMCW34J615S ⁽²⁾	6 15/16 in.																				
QMCW34J700S ⁽²⁾	7 in.																				
QMCW34J180S ⁽²⁾	180 mm																				

⁽¹⁾Pilot tolerance: +0/-0.05 mm (+0/-0.002 in.).

⁽²⁾Six-bolt housing.

QMF FOUR-BOLT SQUARE FLANGE BLOCKS

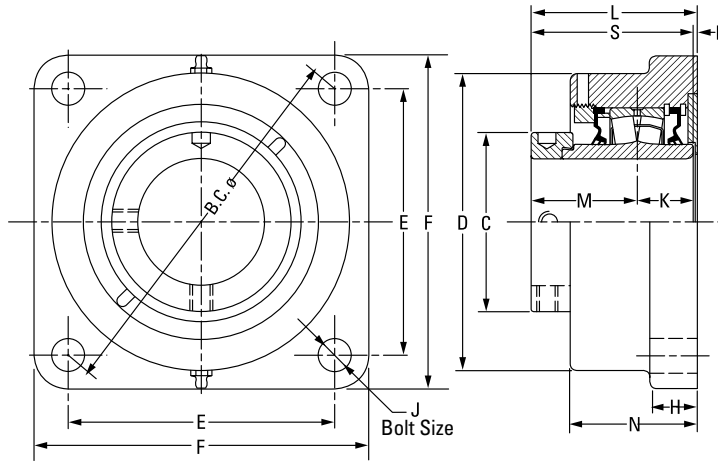

Bearing Part No.	Shaft Dia.	Bearing No.	B.C.	C	D	E	F	H	J	K	L FIX	L EXP	M	N	R	S	Wt.
	mm in.		mm in.	mm in.	mm in.	mm in.	mm in.	mm in.	mm in.	mm in.	mm in.	mm in.	mm in.	mm in.	mm in.	mm in.	lbs. kg
QMF08J035S	35 mm	22208	127.7	60.5	93.7	88.9	117.6	22.4	12	25.4	72.9	74.9	44.5	57.2	3.0	69.9	4.5
QMF08J107S	1 7/16 in.		4.95	2.38	3.69	3.50	4.63	0.88	1/2	1.00	2.87	2.95	1.75	2.25	0.12	2.75	10
QMF08J108S	1 1/2 in.	22208	148.3	60.5	108.0	104.9	136.7	22.4	12	25.4	73.7	75.7	44.5	59.4	3.8	69.9	4.5
			5.84	2.38	4.25	4.13	5.38	0.88	1/2	1.00	2.90	2.98	1.75	2.34	0.15	2.75	10
QMF09J111S	1 1/16 in.	22209	148.3	66.8	118.4	104.9	136.7	22.4	12	25.4	79.5	81.5	47.8	63.5	6.4	73.2	5.0
QMF09J040S	40 mm		5.84	2.63	4.66	4.13	5.38	0.88	1/2	1.00	3.13	3.21	1.88	2.50	0.25	2.88	11
QMF09J112S	1 3/4 in.	22209	157.2	66.8	118.4	111.3	143.0	22.4	12	25.4	79.5	81.5	47.8	63.5	6.4	72.9	5.0
QMF09J045S	45 mm		6.19	2.63	4.66	4.38	5.63	0.88	1/2	1.00	3.13	3.21	1.88	2.50	0.25	2.87	11
QMF10J115S	1 1/16 in.	22210	157.2	71.4	120.7	111.3	139.7	22.4	12	24.4	80.8	82.8	48.0	65.0	7.9	72.9	5.0
QMF10J200S	2 in.		6.19	2.81	4.75	4.38	5.50	0.88	1/2	0.98	3.18	3.26	1.89	2.56	0.31	2.87	11
QMF10J050S	50 mm																
QMF11J203S	2 3/16 in.	22211	175.0	75.9	130.3	124.0	157.2	25.4	16	28.7	82.8	84.8	50.5	66.8	3.3	79.2	6.4
QMF11J204S	2 1/4 in.		6.89	2.99	5.13	4.88	6.19	1.00	5/8	1.13	3.26	3.34	1.99	2.63	0.13	3.12	14
QMF11J055S	55 mm																
QMF13J060S	60 mm	22213	193.0	91.9	146.1	136.7	168.4	25.4	16	31.5	88.6	90.7	54.1	72.4	3.0	85.6	7.7
QMF13J207S	2 7/16 in.		7.60	3.62	5.75	5.38	6.63	1.00	5/8	1.24	3.49	3.57	2.13	2.85	0.12	3.37	17
QMF13J208S	2 1/2 in.																
QMF13J065S	65 mm	22215	215.6	101.9	168.9	152.4	189.0	26.9	20	31.8	96.0	98.0	60.2	76.2	4.1	91.9	10.4
QMF15J211S	2 1/16 in.		8.49	4.01	6.65	6.00	7.44	1.06	3/4	1.25	3.78	3.86	2.37	3.00	0.16	3.62	23
QMF15J212S	2 3/4 in.																
QMF15J070S	70 mm																
QMF15J215S	2 13/16 in.																
QMF15J300S	3 in.																
QMF15J075S	75 mm	22218	251.7	120.9	193.8	177.8	219.2	33.3	20	36.6	107.2	109.2	66.8	84.1	4.8	102.4	15.9
QMF18J303S	3 3/16 in.		9.91	4.76	7.63	7.00	8.63	1.31	3/4	1.44	4.22	4.30	2.59	3.31	0.19	4.03	35
QMF18J304S	3 1/4 in.																
QMF18J080S	80 mm																
QMF18J085S	85 mm																
QMF18J307S	3 7/16 in.																
QMF18J308S	3 1/2 in.	22220	278.4	152.4	224.0	196.9	253.2	38.1	24	41.4	126.2	128.3	75.2	103.1	9.4	116.6	24.9
QMF18J090S	90 mm		10.96	6.00	8.82	7.75	9.97	1.50	7/8	1.63	4.97	5.05	2.96	4.06	0.37	4.59	55
QMF20J311S	3 1/16 in.																
QMF20J312S	3 3/4 in.	22222	314.5	160.0	256.8	222.3	276.4	38.1	24	46.5	150.1	152.1	94.0	106.9	9.7	140.5	28.6
QMF20J315S	3 15/16 in.		12.38	6.30	10.11	8.75	10.88	1.50	7/8	1.83	5.91	5.99	3.70	4.21	0.38	5.53	63
QMF20J400S	4 in.																
QMF20J100S	100 mm																
QMF22J110S	110 mm	22222	314.5	160.0	256.8	222.3	276.4	38.1	24	46.5	150.1	152.1	94.0	106.9	9.7	140.5	28.6
QMF22J407S	4 7/16 in.		12.38	6.30	10.11	8.75	10.88	1.50	7/8	1.83	5.91	5.99	3.70	4.21	0.38	5.53	63
QMF22J408S	4 1/2 in.																
QMF22J115S	115 mm																

QMFL FOUR-BOLT SQUARE FLANGE BLOCKS

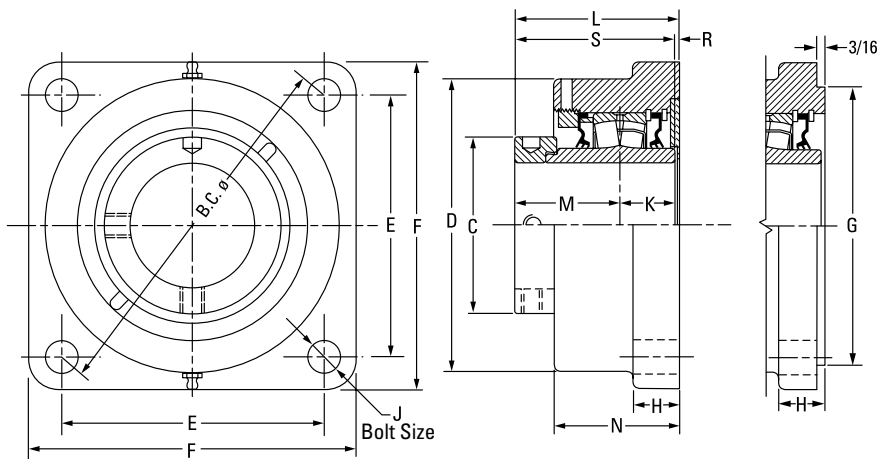

Bearing Part No.	Shaft Dia.	Bearing No.	B.C.	C	D	E	F	G ⁽¹⁾⁽²⁾⁽³⁾	H	J	K	L FIX	L EXP	M	N	R	S	Wt.	
	mm in.		mm in.	mm in.	mm in.	mm in.	mm in.	mm in.	mm in.	mm in.	mm in.	mm in.	mm in.	mm in.	mm in.	mm in.	mm in.	kg lbs.	
QMFL08J035S	35 mm	22208	127.0	60.5	93.7	89.9	117.6	N/A	22.4	12	25.4	72.9	74.9	44.5	57.2	3.0	69.9	4.5	
QMFL08J107S	1 7/16 in.		5.00	2.38	3.69	3.54	4.63		0.88	1/2	1.00	2.87	2.95	1.75	2.25	0.12	2.75	10	
QMFL08J108S	1 1/2 in.																		
QMFL09J111S	1 1/16 in.	22209	139.7	66.8	118.4	98.8	136.7	N/A	22.4	12	25.1	79.5	81.5	47.8	63.5	6.6	72.9	5.0	
QMFL09J040S	40 mm		5.50	2.63	4.66	3.89	5.38		0.88	1/2	0.99	3.13	3.21	1.88	2.50	0.26	2.87	11	
QMFL09J112S	1 3/4 in.																		
QMFL09J045S	45 mm	22210	146.1	71.4	115.3	103.4	131.8	N/A	23.1	12	24.9	80.8	82.8	48.0	62.5	7.9	72.9	5.0	
QMFL10J115S	1 5/16 in.		5.75	2.81	4.54	4.07	5.19		0.91	1/2	0.98	3.18	3.26	1.89	2.46	0.31	2.87	11	
QMFL10J200S	2 in.																		
QMFL10J050S	50 mm	22211	162.1	76.0	130.3	114.3	149.4	N/A	19.1	16	28.7	83.3	85.3	50.5	66.8	3.8	79.2	6.4	
QMFL11J203S	2 3/16 in.		6.38	2.99	5.13	4.50	5.88		0.75	5/8	1.13	3.28	3.36	1.99	2.63	0.15	3.12	14	
QMFL11J204S	2 1/4 in.																		
QMFL11J055S	55 mm	22213	171.5	91.9	146.1	121.2	157.2	N/A	25.4	16	31.5	88.9	90.7	54.1	72.6	3.0	85.6	7.7	
QMFL13J060S	60 mm		6.75	3.62	5.75	4.77	6.19		1.00	5/8	1.24	3.50	3.57	2.13	2.86	0.12	3.37	17	
QMFL13J207S	2 7/16 in.																		
QMFL13J208S	2 1/2 in.	22215	200.2	101.9	168.4	141.2	182.6	N/A	26.9	20	31.8	95.8	97.8	60.2	74.4	3.8	91.9	10.4	
QMFL13J065S	65 mm		7.88	4.01	6.63	5.56	7.19		1.06	3/4	1.25	3.77	3.85	2.37	2.93	0.15	3.62	23	
QMFL15J211S	2 1/16 in.																		
QMFL15J212S	2 3/4 in.	22218	241.3	120.9	193.8	170.7	212.9	187.33	32.5	20	36.6	106.4	108.5	65.8	86.4	4.1	102.4	15.9	
QMFL15J070S	70 mm		9.50	4.76	7.63	6.72	8.38	7.375	1.28	3/4	1.44	4.19	4.27	2.59	3.40	0.16	4.03	35	
QMFL15J215S	2 1/16 in.																		
QMFL15J300S	3 in.	22220	273.1	152.4	229.6	193.0	241.3	215.90	38.1	24	41.4	132.3	134.4	75.2	104.6	15.7	116.6	24.9	
QMFL15J075S	75 mm		10.75	6.00	9.04	7.60	9.50	8.500	1.50	1	1.63	5.21	5.29	2.96	4.12	0.62	4.59	55	
QMFL18J303S	3 3/16 in.																		
QMFL18J304S	3 1/4 in.	22220	273.1	152.4	229.6	193.0	241.3	215.90	38.1	24	41.4	132.3	134.4	75.2	104.6	15.7	116.6	24.9	
QMFL18J080S	80 mm		10.75	6.00	9.04	7.60	9.50	8.500	1.50	1	1.63	5.21	5.29	2.96	4.12	0.62	4.59	55	
QMFL18J085S	85 mm																		
QMFL18J307S	3 7/16 in.	22220	273.1	152.4	229.6	193.0	241.3	215.90	38.1	24	41.4	132.3	134.4	75.2	104.6	15.7	116.6	24.9	
QMFL18J308S	3 1/2 in.																		
QMFL18J090S	90 mm																		
QMFL20J311S	3 1/16 in.	22220	273.1	152.4	229.6	193.0	241.3	215.90	38.1	24	41.4	132.3	134.4	75.2	104.6	15.7	116.6	24.9	
QMFL20J312S	3 3/4 in.																		
QMFL20J315S	3 1/16 in.																		
QMFL20J400S	4 in.	22220	273.1	152.4	229.6	193.0	241.3	215.90	38.1	24	41.4	132.3	134.4	75.2	104.6	15.7	116.6	24.9	
QMFL20J100S	100 mm																		

⁽¹⁾Pilot tolerance: +0/-0.05 mm (+0/-0.002 in.).

⁽²⁾Add (p) to the end of the housing designation in the part number to order with pilot using G dimension.

⁽³⁾Piloted flange blocks will be quoted (price and delivery) upon request. For optional spigot on flange side, insert the letter P as seen in the following example: QMFP**J***S.

QMFMD FOUR-BOLT SQUARE FLANGE BLOCKS

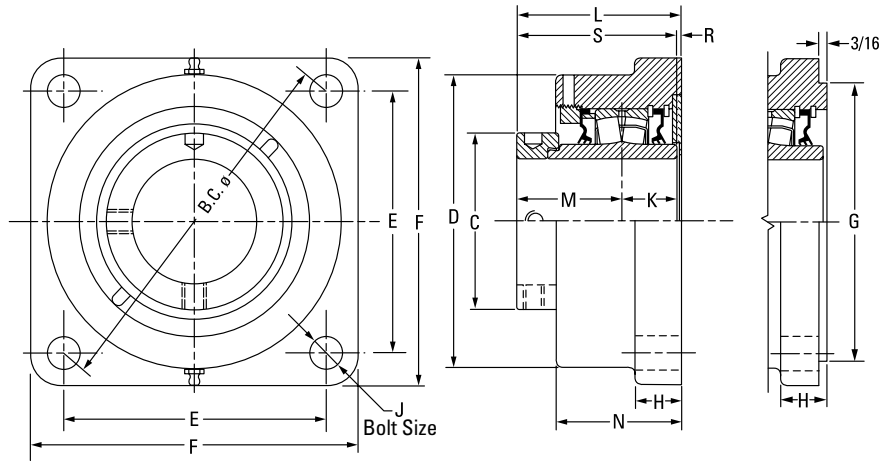

Bearing Part No.	Shaft Dia.	Bearing No.	B.C.	C	D	E	F	H	J	K	L FIX	L EXP	M	N	R	S	Wt.
	mm in.		mm in.	mm in.	mm in.	mm in.	mm in.	mm in.	mm in.	mm in.	mm in.	mm in.	mm in.	mm in.	mm in.	mm in.	kg lbs.
QMFMD08J035S	35 mm	22208	143.8	60.5	108.0	101.6	130.3	22.4	12	25.4	72.9	74.9	44.5	59.4	3.0	69.9	4.5
QMFMD08J107S	1 7/16 in.		5.66	2.38	4.25	4.00	5.13	0.88	1/2	1.00	2.87	2.95	1.75	2.34	0.12	2.75	10
QMFMD08J108S	1 1/2 in.	22208	143.8	60.5	108.0	104.9	136.7	22.4	12	25.4	73.7	75.7	44.5	59.4	3.8	69.9	4.5
			5.66	2.38	4.25	4.13	5.38	0.88	1/2	1.00	2.90	2.98	1.75	2.34	0.15	2.75	10
QMFMD09J040S	40 mm	22209	143.8	66.8	108.0	104.9	136.7	22.4	12	25.4	79.5	81.5	47.8	63.5	6.4	73.2	5.0
			5.66	2.63	4.25	4.13	5.38	0.88	1/2	1.00	3.13	3.21	1.88	2.50	0.25	2.88	11
QMFMD09J111S	1 1/16 in.	22209	157.2	66.8	118.4	111.3	143.0	22.4	12	25.4	79.5	81.5	47.8	63.5	6.4	73.2	5.0
QMFMD09J112S	1 3/4 in.		6.19	2.63	4.66	4.38	5.63	0.88	1/2	1.00	3.13	3.21	1.88	2.50	0.25	2.88	11
QMFMD09J045S	45 mm	22210	184.1	73.2	120.7	130.2	165.1	22.4	12	25.4	80.8	82.8	47.5	65.0	7.9	72.9	5.0
QMFMD10J115S	1 1/16 in.		7.25	2.88	4.75	5.13	6.5	0.88	1/2	1.00	3.18	3.26	1.87	2.56	0.31	2.87	11
QMFMD10J200S	2 in.	22211	202.1	82.6	137.9	142.9	174.8	25.4	16	28.7	83.3	85.1	50.8	66.8	3.8	79.5	6.4
QMFMD10J050S	50 mm		7.96	3.25	5.43	5.63	6.88	1.00	5/8	1.13	3.27	3.35	2.00	2.63	0.15	3.13	14
QMFMD11J203S	2 3/16 in.	22213	211.0	96.8	146.1	149.2	187.5	25.4	16	31.5	89.2	91.2	54.6	72.4	3.0	86.1	7.7
QMFMD11J204S	2 1/4 in.		8.31	3.81	5.75	5.88	7.38	1.00	5/8	1.24	3.51	3.59	2.15	2.85	0.12	3.39	17
QMFMD11J055S	55 mm	22215	215.4	109.0	168.9	152.4	189.0	26.9	20	31.8	95.8	97.8	60.2	76.2	3.8	91.9	10.4
QMFMD13J060S	60 mm		8.48	4.29	6.65	6.00	7.44	1.06	3/4	1.25	3.77	3.85	2.37	3.00	0.15	3.62	23
QMFMD13J207S	2 7/16 in.	22218	241.3	130.2	193.8	171.5	212.7	32.5	20	36.6	106.4	108.5	65.8	86.4	4.3	102.4	15.9
QMFMD13J208S	2 1/2 in.		9.50	5.13	7.63	6.72	8.38	1.28	3/4	1.44	4.19	4.27	2.59	3.40	0.17	4.03	35
QMFMD13J065S	65 mm	22218	241.3	130.2	193.8	171.5	212.7	32.5	20	36.6	106.4	108.5	65.8	86.4	4.3	102.4	15.9
QMFMD15J211S	2 1/16 in.		9.50	5.13	7.63	6.72	8.38	1.28	3/4	1.44	4.19	4.27	2.59	3.40	0.17	4.03	35
QMFMD15J212S	2 3/4 in.	22218	241.3	130.2	193.8	171.5	212.7	32.5	20	36.6	106.4	108.5	65.8	86.4	4.3	102.4	15.9
QMFMD15J070S	70 mm		9.50	5.13	7.63	6.72	8.38	1.28	3/4	1.44	4.19	4.27	2.59	3.40	0.17	4.03	35
QMFMD15J215S	2 15/16 in.	22218	241.3	130.2	193.8	171.5	212.7	32.5	20	36.6	106.4	108.5	65.8	86.4	4.3	102.4	15.9
QMFMD15J300S	3 in.		9.50	5.13	7.63	6.72	8.38	1.28	3/4	1.44	4.19	4.27	2.59	3.40	0.17	4.03	35
QMFMD15J075S	75 mm	22218	241.3	130.2	193.8	171.5	212.7	32.5	20	36.6	106.4	108.5	65.8	86.4	4.3	102.4	15.9
QMFMD18J303S	3 3/16 in.		9.50	5.13	7.63	6.72	8.38	1.28	3/4	1.44	4.19	4.27	2.59	3.40	0.17	4.03	35
QMFMD18J304S	3 3/4 in.	22218	241.3	130.2	193.8	171.5	212.7	32.5	20	36.6	106.4	108.5	65.8	86.4	4.3	102.4	15.9
QMFMD18J080S	80 mm		9.50	5.13	7.63	6.72	8.38	1.28	3/4	1.44	4.19	4.27	2.59	3.40	0.17	4.03	35
QMFMD18J085S	85 mm	22218	241.3	130.2	193.8	171.5	212.7	32.5	20	36.6	106.4	108.5	65.8	86.4	4.3	102.4	15.9
QMFMD18J307S	3 7/16 in.		9.50	5.13	7.63	6.72	8.38	1.28	3/4	1.44	4.19	4.27	2.59	3.40	0.17	4.03	35
QMFMD18J308S	3 1/2 in.	22218	241.3	130.2	193.8	171.5	212.7	32.5	20	36.6	106.4	108.5	65.8	86.4	4.3	102.4	15.9
QMFMD18J090S	90 mm		9.50	5.13	7.63	6.72	8.38	1.28	3/4	1.44	4.19	4.27	2.59	3.40	0.17	4.03	35

QMFY ROUND FLANGE BLOCKS

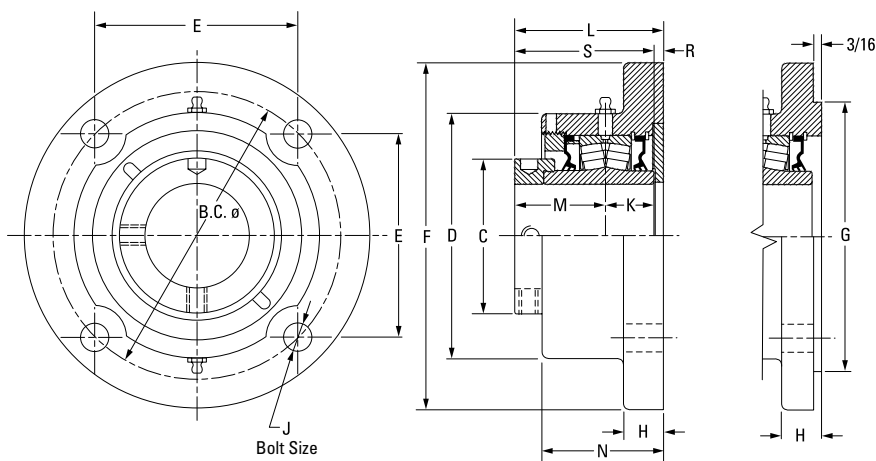

Bearing Part No.	Shaft Dia.	Bearing No.	B.C.	C	D	E	F	G ⁽¹⁾⁽²⁾⁽³⁾	H	J	K	L FIX	L EXP	M	N	R	S	Wt.
	mm in.		mm in.	mm in.	mm in.	mm in.	mm in.	mm in.	mm in.	mm in.	mm in.	mm in.	mm in.	mm in.	mm in.	mm in.	mm in.	kg lbs.
QMFY08J035S ⁽⁴⁾	35 mm	22208	127.0	60.5	108.0	110.0	158.8	90.50	19.1	12	25.4	73.2	75.2	44.5	57.4	3.3	69.9	4.5
QMFY08J107S ⁽⁴⁾	1 7/16 in.		5.00 ⁽⁴⁾	2.38	4.25	4.33 ⁽⁴⁾	6.25	3.563	0.75	1 1/2 ⁽⁴⁾	1.00	2.88	2.96	1.75	2.26	0.13	2.75	10
QMFY08J108S ⁽⁴⁾	1 1/2 in.																	
QMFY09J040S	40 mm	22209	139.7	66.8	104.9	98.8	171.5	103.20	20.6	12	25.1	76.2	78.2	47.8	60.5	3.0	72.9	5.0
QMFY09J111S	1 11/16 in.		5.50	2.63	4.13	3.89	6.75	4.063	0.81	1/2	0.99	3.00	3.08	1.88	2.38	0.12	2.87	11
QMFY09J112S	1 3/4 in.																	
QMFY09J045S	45 mm	22210	146.1	71.4	115.3	103.4	177.8	111.13	19.1	12	24.9	75.9	78.0	48.0	58.4	3.0	72.9	5.4
QMFY10J200S	2 in.		5.75	2.81	4.54	4.07	7.00	4.375	0.75	1/2	0.98	2.99	3.07	1.89	2.30	0.12	2.87	12
QMFY10J050S	50 mm																	
QMFY11J203S	2 3/8 in.	22211	162.1	75.9	130.3	114.3	196.9	127.00	19.1	16	28.7	82.3	84.3	50.8	62.0	3.0	79.2	6.8
QMFY11J204S	2 1/4 in.		6.38	2.99	5.13	4.50	7.75	5.000	0.75	5/8	1.13	3.24	3.32	2.00	2.44	0.12	3.12	15
QMFY11J055S	55 mm																	
QMFY13J060S	60 mm	22213	171.5	91.9	146.1	121.2	206.5	138.13	23.9	16	31.5	88.1	90.4	54.1	72.4	2.3	85.6	8.6
QMFY13J207S	2 7/16 in.		6.75	3.62	5.75	4.77	8.13	5.438	0.94	5/8	1.24	3.47	3.56	2.13	2.85	0.09	3.37	19
QMFY13J208S	2 1/2 in.																	
QMFY13J065S	65 mm	22215	199.9	101.9	168.4	141.2	241.3	160.35	23.9	20	31.8	98.6	100.6	60.2	76.2	6.4	91.9	12.7
QMFY15J211S	2 11/16 in.		7.87	4.01	6.63	5.56	9.50	6.313	0.94	3/4	1.25	3.88	3.96	2.37	3.00	0.25	3.62	28
QMFY15J212S	2 3/4 in.																	
QMFY15J070S	70 mm	22215	199.9	101.9	168.4	141.2	241.3	160.35	23.9	20	31.8	98.6	100.6	60.2	76.2	6.4	91.9	12.7
QMFY15J215S	2 3/8 in.		7.87	4.01	6.63	5.56	9.50	6.313	0.94	3/4	1.25	3.88	3.96	2.37	3.00	0.25	3.62	28
QMFY15J300S	3 in.																	
QMFY15J075S	75 mm																	

⁽¹⁾Pilot tolerance: +0/-0.05 mm (+0/-0.002 in.).

⁽²⁾Add (p) to the end of the housing designation in the part number to order with pilot using G dimension.

⁽³⁾Piloted flange blocks will be quoted (price and delivery) upon request. For optional spigot on flange side, insert the letter P as seen in the following example: QMFP**J***S.

⁽⁴⁾Three-bolt housing.

NOTE: Housings also are available with a 3/16 in. machined pilot. Please contact your Timken engineer for more information.

Continued on next page.

QMFY ROUND FLANGE BLOCKS – continued

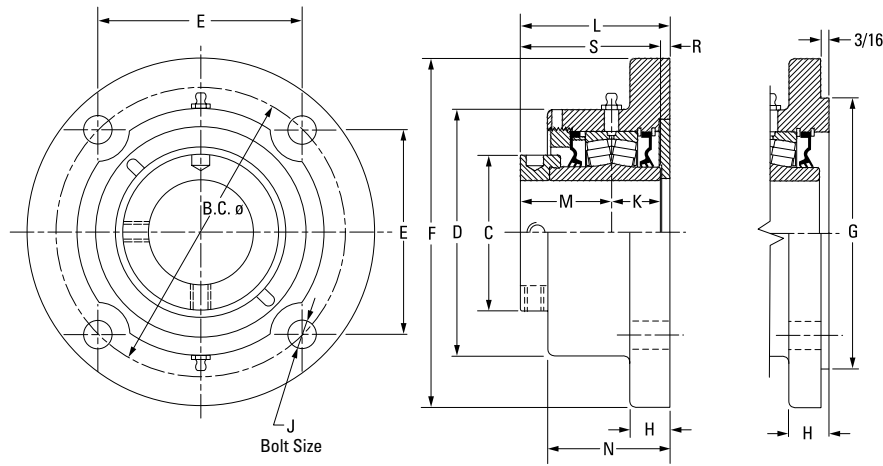

Continued from previous page.

Bearing Part No.	Shaft Dia.	Bearing No.	B.C.	C	D	E	F	G ⁽¹⁾⁽²⁾⁽³⁾	H	J	K	L FIX	L EXP	M	N	R	S	Wt.
	mm in.		mm in.	mm in.	mm in.	mm in.	mm in.	mm in.	mm in.	mm in.	mm in.	mm in.	mm in.	mm in.	mm in.	mm in.	mm in.	kg lbs.
QMFY18J303S	3 3/16 in.																	
QMFY18J304S	3 1/4 in.																	
QMFY18J080S	80 mm																	
QMFY18J085S	85 mm	22218	241.3 9.50	120.9 4.76	193.8 7.63	170.7 6.72	282.7 11.13	N/A	28.7 1.13	24 7/8	36.6 1.44	108.7 4.28	110.7 4.36	65.8 2.59	85.3 3.36	6.4 0.25	102.4 4.03	19.1 42
QMFY18J307S	3 7/16 in.																	
QMFY18J308S	3 1/2 in.																	
QMFY18J090S	90 mm																	
QMFY20J311S	3 11/16 in.																	
QMFY20J312S	3 3/4 in.																	
QMFY20J315S	3 15/16 in.	22220	273.1 10.75	152.4 6.00	222.5 8.76	193.0 7.60	320.8 12.63	N/A	28.7 1.13	24 1	41.4 1.63	123.7 4.87	125.7 4.95	75.2 2.96	103.1 4.06	6.9 0.27	116.6 4.59	29.9 66
QMFY20J400S	4 in.																	
QMFY20J100S	100 mm																	
QMFY22J110S ⁽⁵⁾	110 mm																	
QMFY22J407S ⁽⁵⁾	4 7/16 in.	22222	327.2 12.88 ⁽⁵⁾	160.0 6.30	254.0 10.00	163.6 6.44 ⁽⁵⁾	384.3 15.13	N/A	31.8 1.25	24 1 ⁽⁵⁾	46.5 1.83	143.5 5.65	145.5 5.73	94.0 3.70	100.3 3.95	3.0 0.12	140.5 5.53	46.3 102
QMFY22J408S ⁽⁵⁾	4 1/2 in.																	
QMFY22J115S ⁽⁵⁾	115 mm																	
QMFY26J125S ⁽⁵⁾	125 mm																	
QMFY26J415S ⁽⁵⁾	4 15/16 in.	22226	355.6 14.00 ⁽⁵⁾	175.0 6.89	284.2 11.19	177.8 7.00 ⁽⁵⁾	419.1 16.50	N/A	38.1 1.50	24 1 1/8 ⁽⁵⁾	58.7 2.31	170.2 6.70	172.2 6.78	94.7 3.73	138.4 5.45	16.8 0.66	153.4 6.04	52.2 115
QMFY26J500S ⁽⁵⁾	5 in.																	
QMFY26J130S ⁽⁵⁾	130 mm																	

⁽¹⁾Pilot tolerance: +0/-0.05 mm (+0/-0.002 in.).

⁽²⁾Add (p) to the end of the housing designation in the part number to order with pilot using G dimension.

⁽³⁾Piloted flange blocks will be quoted (price and delivery) upon request. For optional spigot on flange side, insert the letter P as seen in the following example: QMFP**J***S.

⁽⁴⁾Three-bolt housing.

⁽⁵⁾Six-bolt housing.

NOTE: Housings also are available with a 3/16 in. machined pilot. Please contact your Timken engineer for more information.

QMFx 5000 SERIES SQUARE FLANGE BLOCKS

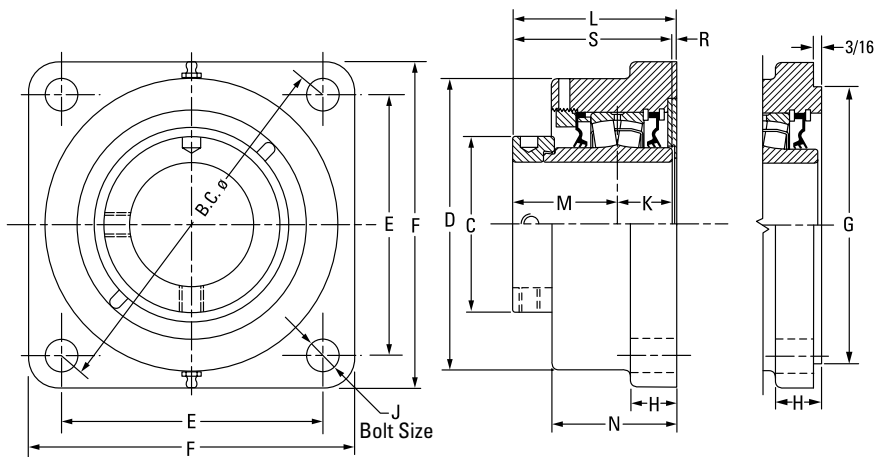

Bearing Part No.	Shaft Dia.	Bearing No.	B.C.	C	D	E	F	G ⁽¹⁾⁽²⁾⁽³⁾	H	J	K	L FIX	L EXP	M	N	R	S	Wt.																	
																		kg lbs.																	
	mm in.		mm in.	mm in.	mm in.	mm in.	mm in.	mm in.	mm in.	mm in.	mm in.	mm in.	mm in.	mm in.	mm in.	mm in.	mm in.	mm in.																	
QMFx08J035S	35 mm	22208	133.6	59.9	93.7	94.5	117.6	90.50	22.1	12	25.4	72.9	74.9	44.5	57.2	3.0	69.9	4.5																	
QMFx08J107S	1 7/16 in.		5.26	2.36	3.69	3.72	4.63	3.563	0.88	1/2	1.00	2.87	2.95	1.75	2.25	0.12	2.75	10																	
QMFx08J108S	1 1/2 in.	22208	139.7	59.9	108.0	98.8	130.3	103.20	22.1	12	25.4	73.7	75.7	44.5	59.4	3.81	69.9	4.5																	
QMFx09J040S	40 mm	22209	139.7	66.8	108.0	98.8	130.3	103.20	22.1	12	25.1	79.5	81.5	47.8	63.5	6.4	72.9	5.0																	
QMFx09J111S	1 1/16 in.																		5.50	2.63	4.25	3.89	5.13	4.063	0.88	1/2	0.99	3.13	3.21	1.88	2.50	0.25	2.87	11	
QMFx09J112S	1 3/4 in.																		22210	146.1	71.4	120.7	103.1	134.9	111.13	22.1	12	24.9	80.8	82.8	48.0	65.0	7.9	72.9	5.0
QMFx09J045S	45 mm																																		
QMFx10J115S	1 5/16 in.	22211	161.5	75.9	130.3	114.3	149.4	127.00	25.4	16	28.7	83.1	85.1	50.5	66.8	3.3	79.2	5.0																	
QMFx10J200S	2 in.																		6.36	2.99	5.13	4.50	5.88	5.000	1.00	5/8	1.13	3.27	3.35	1.99	2.63	0.13	3.12	11	
QMFx10J050S	50 mm																		22213	180.8	91.9	146.1	127.8	157.2	138.13	25.4	16	31.5	89.2	91.2	54.1	72.4	3.0	85.6	6.4
QMFx11J203S	2 3/16 in.	7.12	3.62	5.75	5.03	6.19	5.438	1.00	5/8	1.24	3.51	3.59	2.13	2.85	0.12	3.37	14																		
QMFx11J204S	2 1/4 in.	22215	215.9	102.1	168.9	152.7	189.0	160.35	26.9	20	31.8	96.0	98.0	60.2	76.2	4.1	91.9	7.7																	
QMFx11J055S	55 mm																		8.50	4.02	6.65	6.01	7.44	6.313	1.06	3/4	1.25	3.78	3.86	2.37	3.00	0.16	3.62	17	
QMFx13J060S	60 mm	22215	215.9	102.1	168.9	152.7	189.0	160.35	26.9	20	31.8	96.0	98.0	60.2	76.2	4.1	91.9	7.7																	
QMFx13J207S	2 7/16 in.																		8.50	4.02	6.65	6.01	7.44	6.313	1.06	3/4	1.25	3.78	3.86	2.37	3.00	0.16	3.62	17	
QMFx13J208S	2 1/2 in.	22215	215.9	102.1	168.9	152.7	189.0	160.35	26.9	20	31.8	96.0	98.0	60.2	76.2	4.1	91.9	7.7																	
QMFx13J065S	65 mm																		8.50	4.02	6.65	6.01	7.44	6.313	1.06	3/4	1.25	3.78	3.86	2.37	3.00	0.16	3.62	17	
QMFx15J211S	2 1/16 in.	22215	215.9	102.1	168.9	152.7	189.0	160.35	26.9	20	31.8	96.0	98.0	60.2	76.2	4.1	91.9	7.7																	
QMFx15J212S	2 3/4 in.																		8.50	4.02	6.65	6.01	7.44	6.313	1.06	3/4	1.25	3.78	3.86	2.37	3.00	0.16	3.62	17	
QMFx15J070S	70 mm	22215	215.9	102.1	168.9	152.7	189.0	160.35	26.9	20	31.8	96.0	98.0	60.2	76.2	4.1	91.9	7.7																	
QMFx15J215S	2 13/16 in.																		8.50	4.02	6.65	6.01	7.44	6.313	1.06	3/4	1.25	3.78	3.86	2.37	3.00	0.16	3.62	17	
QMFx15J300S	3 in.	22215	215.9	102.1	168.9	152.7	189.0	160.35	26.9	20	31.8	96.0	98.0	60.2	76.2	4.1	91.9	7.7																	
QMFx15J075S	75 mm																		8.50	4.02	6.65	6.01	7.44	6.313	1.06	3/4	1.25	3.78	3.86	2.37	3.00	0.16	3.62	17	

⁽¹⁾Pilot tolerance: +0/-0.05 mm (+0/-0.002 in.).

⁽²⁾Add (p) to the end of the housing designation in the part number to order with pilot using G dimension.

⁽³⁾Piloted flange blocks will be quoted (price and delivery) upon request. For optional spigot on flange side, insert the letter P as seen in the following example: QMFP**J***S.

⁽⁴⁾Six-bolt round housing.

Continued on next page.

QMF5000 SERIES SQUARE FLANGE BLOCKS – continued

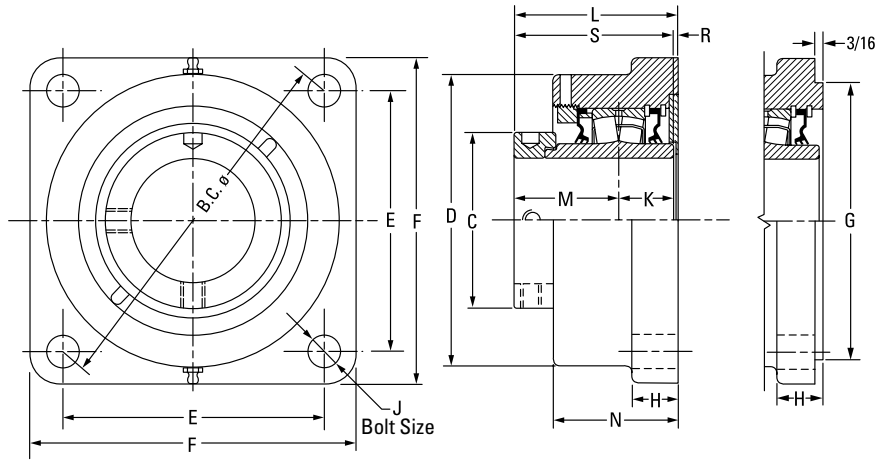

Continued from previous page.

Bearing Part No.	Shaft Dia.	Bearing No.	B.C.	C	D	E	F	G ⁽¹⁾⁽²⁾⁽³⁾	H	J	K	L FIX	L EXP	M	N	R	S	Wt.
	mm in.		mm in.	mm in.	mm in.	mm in.	mm in.	mm in.	mm in.	mm in.	mm in.	mm in.	mm in.	mm in.	mm in.	mm in.	mm in.	kg lbs.
QMF18J303S	3 3/8 in.	22218	241.3 9.50	120.9 4.76	193.8 7.63	170.7 6.72	212.9 8.38	187.33 7.375	33.3 1.31	20 3/4	36.6 1.44	107.2 4.22	109.2 4.30	65.8 2.59	84.1 3.31	4.8 0.19	102.4 4.03	10.4 23
QMF18J304S	3 1/4 in.																	
QMF18J080S	80 mm																	
QMF18J085S	85 mm																	
QMF18J307S	3 7/8 in.																	
QMF18J308S	3 1/2 in.																	
QMF18J090S	90 mm	22220	298.5 11.75	152.4 6.00	215.9 8.50	211.1 8.31	268.2 10.56	225.43 8.875	38.1 1.50	24 7/8	41.4 1.63	126.0 4.96	128.0 5.04	75.2 2.96	103.1 4.06	9.4 0.37	116.8 4.60	15.9 35
QMF20J311S	3 11/16 in.																	
QMF20J312S	3 3/4 in.																	
QMF20J315S	3 15/16 in.																	
QMF20J400S	4 in.																	
QMF20J100S	100 mm																	
QMF22J110S ⁽⁴⁾	110 mm	22222	327.2 12.88 ⁽¹⁾	160.0 6.30	256.5 10.10	163.6 6.44 ⁽¹⁾	384.3 15.13	263.53 10.375	31.8 1.25	24 1 ⁽¹⁾	46.5 1.83	143.8 5.66	145.8 5.74	94.0 3.70	106.9 4.21	3.3 0.13	140.5 5.53	46.3 102
QMF22J407S ⁽⁴⁾	4 7/8 in.																	
QMF22J408S ⁽⁴⁾	4 1/2 in.																	
QMF22J115S ⁽⁴⁾	115 mm																	
QMF26J125S ⁽⁴⁾	125 mm	22226	355.6 14.00 ⁽¹⁾	175.0 6.89	284.2 11.19	177.8 7.00 ⁽¹⁾	419.1 16.50	284.18 11.188	38.1 1.50	24 1 1/8 ⁽¹⁾	58.7 2.31	172.2 6.78	174.2 6.86	94.7 3.73	135.1 5.32	17.3 0.68	153.4 6.04	52.2 115
QMF26J415S ⁽⁴⁾	4 15/16 in.																	
QMF26J500S ⁽⁴⁾	5 in.																	
QMF26J130S ⁽⁴⁾	130 mm																	

⁽¹⁾Pilot tolerance: +0/-0.05 mm (+0/-0.002 in.).

⁽²⁾Add (p) to the end of the housing designation in the part number to order with pilot using G dimension.

⁽³⁾Piloted flange blocks will be quoted (price and delivery) upon request. For optional spigot on flange side, insert the letter P as seen in the following example: QMFP**J***S.

⁽⁴⁾Six-bolt round housing.

QMMC CARTRIDGE BLOCKS

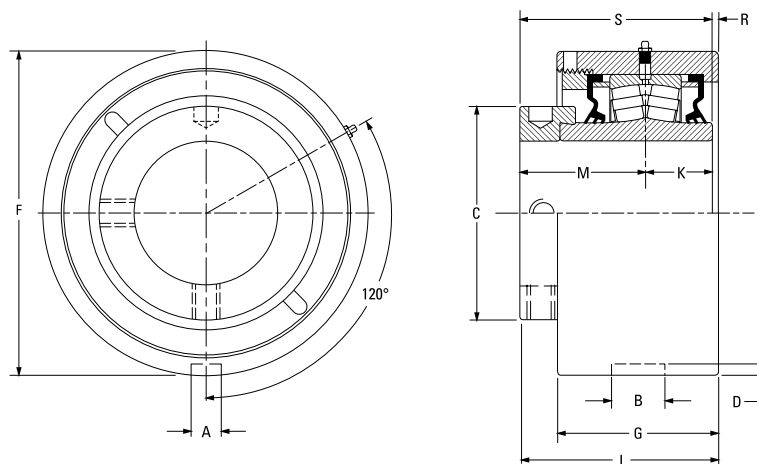

Bearing Part No.	Shaft Dia.	Bearing No.	A	B	C	D	F	G	K	L FIX	L EXP	M	R	S	Wt.	
	mm in.		mm in.	mm in.	mm in.	mm in.	mm in.	mm in.	mm in.	mm in.	mm in.	mm in.	mm in.	mm in.	kg lbs.	
QMMC10J115S	1 1/16 in.	22210	13.5	23.1	71.4	4.8	104.78 (+0/-0.05)	62.2	24.9	79.2	81.3	48.0	6.1	72.9	3.6	
QMMC10J200S	2 in.		0.53	0.91	2.81	0.19	4.125 (+0/-0.002)	2.45	0.98	3.12	3.20	1.89	0.24	2.87	8	
QMMC10J050S	50 mm															
QMMC11J203S	2 3/16 in.	22211	13.5	23.1	75.9	4.8	115.09 (+0/-0.05)	65.5	28.7	83.6	85.6	50.5	4.1	79.2	4.5	
QMMC11J204S	2 1/4 in.		0.53	0.91	2.99	0.19	4.531 (+0/-0.002)	2.58	1.13	3.29	3.37	1.99	0.16	3.12	10	
QMMC11J055S	55 mm															
QMMC13J060S ⁽¹⁾	60 mm	22213	13.5	23.1	91.9	4.8	127.00 (+0/-0.05)	69.3	31.5	85.6	87.6	54.1	0.0	85.6	5.4	
QMMC13J207S ⁽¹⁾	2 7/16 in.		0.53	0.91	3.62	0.19	5.000 (+0/-0.002)	2.73	1.24	3.37	3.45	2.13	0.00	3.37	12	
QMMC13J208S ⁽¹⁾	2 1/2 in.															
QMMC13J065S ⁽¹⁾	65 mm															
QMMC15J211S	2 1/16 in.	22215	15.0	26.2	101.9	6.4	149.225 (+0/-0.05)	79.8	31.8	100.1	102.1	60.2	8.1	91.9	8.2	
QMMC15J212S	2 3/4 in.		0.59	1.03	4.01	0.25	5.875 (+0/-0.002)	3.14	1.25	3.94	4.02	2.37	0.32	3.62	18	
QMMC15J070S	70 mm															
QMMC15J215S	2 5/16 in.															
QMMC15J300S	3 in.															
QMMC15J075S	75 mm	22218	15.0	26.9	120.9	7.1	171.45 (+0/-0.05)	87.6	36.6	109.7	111.8	65.0	7.4	102.4	11.8	
QMMC18J303S	3 3/16 in.		0.59	1.06	4.76	0.28	6.750 (+0/-0.002)	3.45	1.44	4.32	4.40	2.56	0.29	4.03	26	
QMMC18J304S	3 1/4 in.															
QMMC18J080S	80 mm															
QMMC18J085S	85 mm															
QMMC18J307S	3 7/16 in.															
QMMC18J308S	3 1/2 in.	22220	19.8	32.5	152.4	7.9	206.375 (+0/-0.05)	105.2	41.4	128.0	130.0	75.2	11.4	116.6	14.5	
QMMC20J311S	3 1/16 in.		0.78	1.28	6.00	0.31	8.125 (+0/-0.002)	4.14	1.63	5.039	5.12	2.96	0.45	4.59	32	
QMMC20J312S	3 3/4 in.															
QMMC20J315S	3 5/16 in.															
QMMC20J400S	4 in.															
QMMC20J100S	100 mm															

⁽¹⁾The grub screw is located in the external housing nut to secure to the housing.

Continued on next page.

QMMC CARTRIDGE BLOCKS – continued

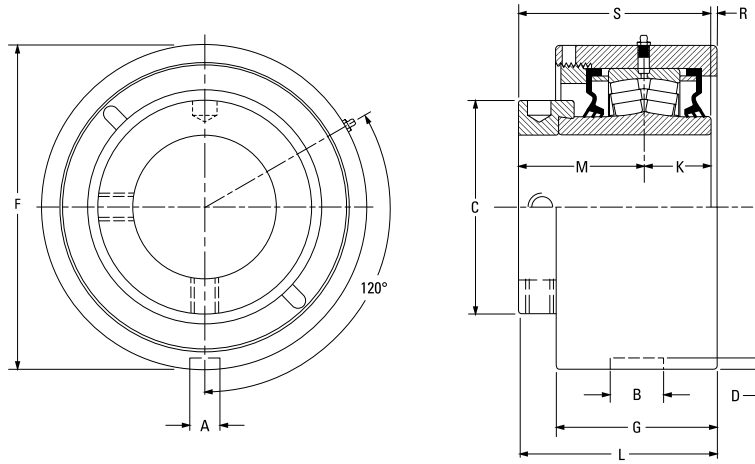

Continued from previous page.

Bearing Part No.	Shaft Dia.	Bearing No.	A	B	C	D	F	G	K	L FIX	L EXP	M	R	S	Wt.
	mm in.		mm in.	mm in.	mm in.	mm in.	mm in.	mm in.	mm in.	mm in.	mm in.	mm in.	mm in.	mm in.	kg lbs.
QMMC22J110S	110 mm	22222	19.8 0.78	38.1 1.50	160.0 6.30	7.9 0.31	222.25 (+0/-0.08) 8.75 (+0/-0.003)	108.5 4.27	46.5 1.83	148.0 5.83	150.1 5.91	94.0 3.70	7.6 0.30	140.5 5.53	18.1 40
QMMC22J407S	4 7/16 in.														
QMMC22J408S	4 1/2 in.														
QMMC22J115S	115 mm														
QMMC26J125S	125 mm	22226	19.8 0.78	38.1 1.50	175.0 6.89	7.9 0.31	265.13 (+0/-0.08) 10.438 (+0/-0.003)	141.7 5.58	58.7 2.31	165.4 6.51	167.4 6.59	94.7 3.73	11.9 0.47	153.4 6.04	31.8 70
QMMC26J415S	4 15/16 in.														
QMMC26J500S	5 in.														
QMMC26J130S	130 mm														
QMMC30J507S	5 7/16 in.	23230	19.8 0.78	38.1 1.50	205.0 8.07	5.6 0.22	292.10 (+0/-0.08) 11.500 (+0/-0.003)	154.4 6.08	75.9 2.99	188.2 7.41	190.2 7.49	116.1 4.57	-3.8 -0.15	192.0 7.56	88.0 194
QMMC30J508S	5 1/2 in.														
QMMC30J140S	140 mm														
QMMC30J515S	5 15/16 in.														
QMMC30J600S	6 in.	23230	19.8 0.78	38.1 1.50	205.0 8.07	5.6 0.22	311.15 (+0/-0.08) 12.250 (+0/-0.003)	154.4 6.08	75.9 2.99	188.2 7.41	190.2 7.49	116.1 4.57	-3.8 -0.15	192.0 7.56	87.1 192
QMMC30J150S	150 mm														
QMMC34J607S	6 7/16 in.														
QMMC34J608S	6 1/2 in.														
QMMC34J170S	170 mm	23234	19.8 0.78	38.1 1.50	235.0 9.25	5.6 0.22	344.50 (+0/-0.08) 13.563 (+0/-0.003)	181.1 7.13	85.1 3.35	219.5 8.64	221.5 8.72	129.0 5.08	5.33 0.21	214.1 8.43	155.6 343
QMMC34J615S	6 15/16 in.														
QMMC34J700S	7 in.														
QMMC34J180S	180 mm														

⁽¹⁾The grub screw is located in the external housing nut to secure to the housing.

QMTU TAKE-UP BLOCKS

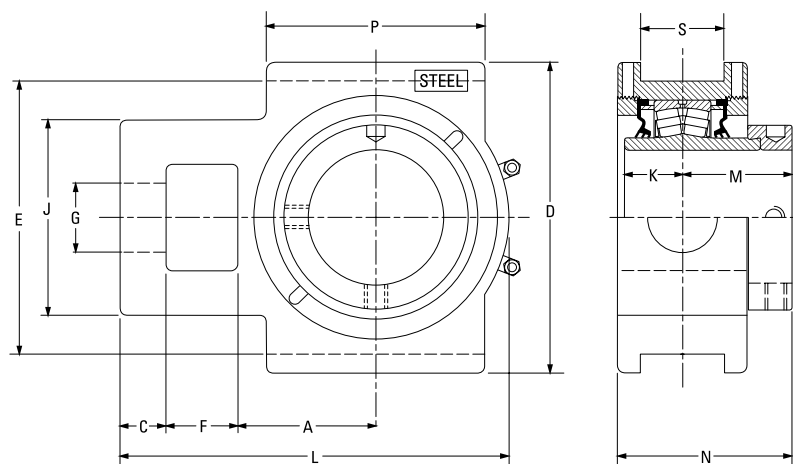

Bearing Part No.	Shaft Dia.	Bearing No.	A	C	D	E	F	G	J	K	L	M	N	P	S	Wt.
			mm in.	mm in.	mm in.	mm in.	mm in.	mm in.	mm in.	mm in.	mm in.	mm in.	mm in.	mm in.	mm in.	mm in.
QMTU10J115S	1 1/16 in.	22210	54.1	19.1	120.7	101.6	26.9	26.9	73.2	24.9	153.4	48.0	76.7	88.9	17.5	7.7
QMTU10J200S	2 in.		2.13	0.75	4.75	4.00	1.06	1.06	2.88	0.98	6.04	1.89	3.02	3.50	0.69	17
QMTU10J050S	50 mm															
QMTU11J203S	2 3/16 in.	22211	60.5	19.1	133.4	114.3	30.2	30.2	88.9	28.7	167.9	50.5	82.8	95.3	20.6	9.5
QMTU11J204S	2 1/4 in.		2.38	0.75	5.25	4.50	1.19	1.19	3.50	1.13	6.61	1.99	3.26	3.75	0.81	21
QMTU11J055S	55 mm															
QMTU13J060S	60 mm	22213	69.9	22.4	149.4	130.3	33.3	34.9	95.3	31.5	193.8	54.1	90.7	120.7	26.9	12.2
QMTU13J207S	2 7/16 in.		2.75	0.88	5.88	5.13	1.31	1.38	3.75	1.24	7.63	2.13	3.57	4.75	1.06	27
QMTU13J208S	2 1/2 in.															
QMTU13J065S	65 mm	22215	76.2	25.4	171.5	150.9	39.6	39.6	108.0	31.8	219.7	60.2	97.0	120.7	46.0	15.9
QMTU15J211S	2 1/16 in.		3.00	1.00	6.75	5.94	1.56	1.56	4.25	1.25	8.65	2.37	3.82	4.75	1.81	35
QMTU15J212S	2 3/4 in.															
QMTU15J070S	70 mm	22218	92.2	25.4	193.8	173.0	46.0	49.3	124.0	36.6	257.0	65.8	106.4	158.8	46.0	20.0
QMTU15J215S	2 15/16 in.		3.63	1.00	7.63	6.81	1.81	1.94	4.88	1.44	10.12	2.59	4.19	6.25	1.81	44
QMTU18J303S	3 3/16 in.															
QMTU18J304S	3 1/4 in.	22220	104.9	28.7	239.8	219.2	54.1	52.3	143.0	41.4	296.9	75.4	120.4	177.8	52.3	26.3
QMTU18J080S	80 mm		4.13	1.13	9.44	8.63	2.13	2.06	5.63	1.63	11.69	2.97	4.74	7.00	2.06	58
QMTU18J085S	85 mm															
QMTU18J307S	3 7/16 in.	22222	128.5	38.1	263.7	241.3	54.1	54.1	162.1	46.5	341.4	94.0	143.8	199.9	52.3	36.4
QMTU18J308S	3 1/2 in.		5.06	1.50	10.38	9.50	2.13	2.13	6.38	1.83	13.44	3.70	5.66	7.87	2.06	80
QMTU18J090S	90 mm															
QMTU20J311S	3 1/16 in.	22226	134.9	63.5	285.8	260.4	63.5	60.5	177.8	58.7	396.7	94.7	151.1	228.6	52.3	60.8
QMTU20J312S	3 3/4 in.		5.31	2.50	11.25	10.25	2.50	2.38	7.00	2.31	15.62	3.73	5.95	9.00	2.06	134
QMTU20J315S	3 15/16 in.															
QMTU20J400S	4 in.	22226	134.9	63.5	285.8	260.4	63.5	60.5	177.8	58.7	396.7	94.7	151.1	228.6	52.3	60.8
QMTU20J100S	100 mm		5.31	2.50	11.25	10.25	2.50	2.38	7.00	2.31	15.62	3.73	5.95	9.00	2.06	134
QMTU22J110S	110 mm															
QMTU22J407S	4 7/16 in.	22226	134.9	63.5	285.8	260.4	63.5	60.5	177.8	58.7	396.7	94.7	151.1	228.6	52.3	60.8
QMTU22J408S	4 1/2 in.		5.31	2.50	11.25	10.25	2.50	2.38	7.00	2.31	15.62	3.73	5.95	9.00	2.06	134
QMTU22J115S	115 mm															
QMTU26J125S	125 mm	22226	134.9	63.5	285.8	260.4	63.5	60.5	177.8	58.7	396.7	94.7	151.1	228.6	52.3	60.8
QMTU26J415S	4 15/16 in.		5.31	2.50	11.25	10.25	2.50	2.38	7.00	2.31	15.62	3.73	5.95	9.00	2.06	134
QMTU26J500S	5 in.															
QMTU26J130S	130 mm															

NOTE: Please refer to page 250 for take-up frames.

QMTP – TOP ANGLE TAKE-UP BLOCKS

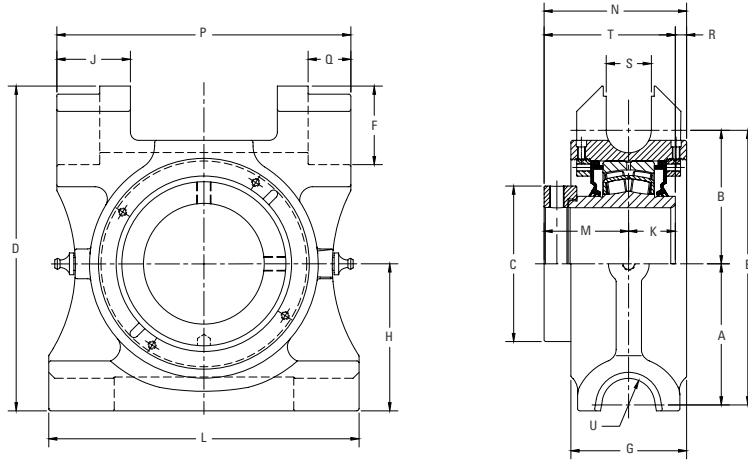

Bearing Part No.	Shaft Dia.	Bearing No.	A	B	C	D	E	F	G	H	J	K	L	M	N	P	Q	R	S	T	U
			mm in.	mm in.	mm in.	mm in.	mm in.	mm in.	mm in.	mm in.	mm in.	mm in.	mm in.	mm in.	mm in.	mm in.	mm in.	mm in.	mm in.	mm in.	mm in.
QMTP10J115S	1 1/8 in.	22210	71.4	60.5	71.4	163.6	131.8	42.2	62.7	77.8	41.9	24.9	165.1	48.0	79.3	152.4	20.6	6.4	22.4	72.9	20.6
QMTP10J200S	2 in.		2.81	2.38	2.81	6.44	5.19	1.66	2.47	3.06	1.65	0.98	6.50	1.89	3.12	6.00	0.81	.025	0.88	2.87	0.81
QMTP10J050S	50 mm																				
QMTP11J203S	2 3/8 in.	22211	82.6	72.8	79.1	193.8	155.4	49.3	69.9	88.9	44.4	28.6	190.6	50.6	88.3	177.8	26.9	9.1	28.4	79.2	20.6
QMTP11J204S	2 1/4 in.		3.25	2.87	3.12	7.63	6.12	1.94	2.75	3.50	1.75	1.13	7.50	1.99	3.48	7.00	1.06	0.36	1.12	3.12	0.81
QMTP11J055S	55 mm																				
QMTP13J207S	2 7/8 in.	22213	96.8	84.6	91.9	210.3	181.4	47.8	81.0	97.5	44.5	31.5	215.9	54.2	94.7	203.2	26.9	9.0	28.4	85.7	20.6
QMTP13J208S	2 1/2 in.		3.81	3.33	3.62	8.28	7.14	1.88	3.19	3.84	1.75	1.24	8.50	2.13	3.73	8.00	1.06	0.35	1.12	3.37	0.81
QMTP13J060S	60 mm																				
QMTP15J211S	2 1/8 in.	22215	97.0	84.1	101.7	215.9	181.1	49.3	81.0	101.4	44.4	31.8	215.9	60.2	100.7	203.2	26.9	8.7	28.4	92.0	20.6
QMTP15J212S	2 3/4 in.		3.82	3.31	4.00	8.50	7.13	1.94	3.19	3.99	1.75	1.25	8.50	2.37	3.96	8.00	1.06	0.34	1.12	3.62	0.81
QMTP15J070S	70 mm																				
QMTP15J300S	3 in.	22218	109.7	103.9	121.0	252.5	213.6	61.3	90.0	114.3	57.1	36.3	241.3	65.8	110.9	228.6	33.3	8.8	35.1	102.1	20.6
QMTP15J075S	75 mm		4.32	4.09	4.76	9.94	8.41	2.41	3.54	4.50	2.25	1.43	9.50	2.59	4.37	9.00	1.31	0.35	1.38	4.02	0.81
QMTP18J303S	3 3/8 in.																				
QMTP18J304S	3 1/4 in.	22220	121.0	117.6	152.5	289.1	238.6	63.5	79.5	139.7	58.7	41.3	279.4	75.5	126.2	266.7	33.3	9.4	35.1	116.8	20.6
QMTP18J080S	80 mm		4.76	4.63	6.00	11.38	9.39	2.50	3.13	5.50	2.31	1.63	11.00	2.97	4.97	10.50	1.31	0.37	1.37	4.60	0.81
QMTP18J085S	85 mm																				
QMTP20J311S	3 1/8 in.	22220	121.0	117.6	152.5	289.1	238.6	63.5	79.5	139.7	58.7	41.3	279.4	75.5	126.2	266.7	33.3	9.4	35.1	116.8	20.6
QMTP20J312S	3 3/4 in.		4.76	4.63	6.00	11.38	9.39	2.50	3.13	5.50	2.31	1.63	11.00	2.97	4.97	10.50	1.31	0.37	1.37	4.60	0.81
QMTP20J315S	3 1/2 in.																				
QMTP20J400S	4 in.	22220	121.0	117.6	152.5	289.1	238.6	63.5	79.5	139.7	58.7	41.3	279.4	75.5	126.2	266.7	33.3	9.4	35.1	116.8	20.6
QMTP20J100S	100 mm		4.76	4.63	6.00	11.38	9.39	2.50	3.13	5.50	2.31	1.63	11.00	2.97	4.97	10.50	1.31	0.37	1.37	4.60	0.81

⁽¹⁾Frame only.

QMMH HANGER BLOCKS

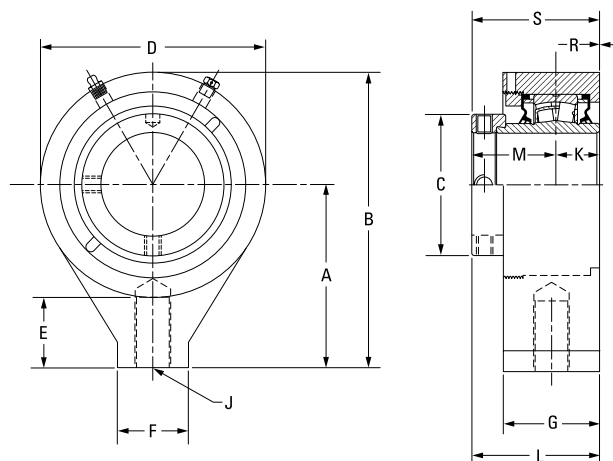

Bearing Part No.	Shaft Dia.	Bearing No.	A	B	C	D	E	F	G	J	K	L	M	R	S	Wt.
	mm in.		mm in.	mm in.	mm in.	mm in.	mm in.	mm in.	mm in.	in.	mm in.	mm in.	mm in.	mm in.	mm in.	kg lbs.
QMMH15J211S	2 1/16 in.	22215	131.8 5.19	212.9 8.38	101.9 4.01	162.1 6.38	50.8 2.00	50.8 2.00	69.9 2.75	1-8UNC	31.8 1.25	91.9 3.62	60.2 2.37	0.0 0.00	91.9 3.62	10.0 22
QMMH15J212S	2 3/4 in.															
QMMH15J070S	70 mm															
QMMH15J215S	2 15/16 in.															
QMMH15J300S	3 in.															
QMMH15J075S	75 mm	22218	160.3 6.31	260.4 10.25	120.9 4.76	200.2 7.88	63.5 2.50	76.2 3.00	76.2 3.00	1 1/4-7UNC	36.6 1.44	99.3 3.91	65.8 2.59	3.0 0.12	102.4 4.03	16.3 36
QMMH18J303S	3 3/16 in.															
QMMH18J304S	3 1/4 in.															
QMMH18J080S	80 mm															
QMMH18J085S	85 mm															
QMMH18J307S	3 7/16 in.															
QMMH18J308S	3 1/2 in.															
QMMH18J090S	90 mm															

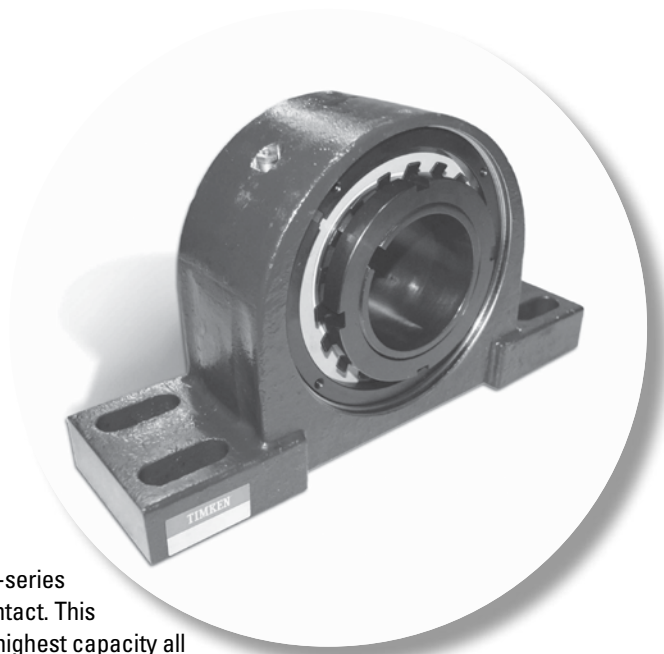

TA/DV TAA/DAA SERIES

The TA/DV and TAA/DAA series feature a 2300-series tapered adapter sleeve for increased shaft contact. This design offers the best shaft concentricity and highest capacity all the while having the ability to accommodate undersized shafting.

The following topics are covered within this section:

Introduction	210
DVP and DAAP Two-Bolt Pillow Blocks	211
TAPA and TAAPA SAF-Style Two-Bolt Pillow Blocks	212
TAPN and TAAPN SN-Style Two-Bolt Pillow Blocks	214
TASD and TAASD Special Duty-Style Two-Bolt Pillow Blocks	216
TADI and TAADI DI-Style Two-Bolt Pillow Block	217
TAPKT and TAAPKT 9000 Series Two-Bolt Pillow Blocks	218
DVPF and DAAPF Four-Bolt Pillow Blocks	219
TAPK and TAAPK 9000 Series Four-Bolt Pillow Blocks	220
TA4SD and TAA4SD Special Duty-Style Four-Bolt Pillow Block	222
TA4DI and TAA4DI DI-Style Four-Bolt Pillow Block	224
TAPH and TAAPH SAF-Style Four-Bolt Pillow Blocks	226
TAAPH SAF 500-Style Four-Bolt Pillow Blocks	228
TAAPHD SDAF 500-Style Four-Bolt Pillow Blocks	229
TAAPH6 SAF 600-Style Four-Bolt Pillow Blocks	230
TAAPH6D SDAF 600-Style Four Bolt Pillow Blocks	231
TAAPH0 SAF 230-Style Four-Bolt Pillow Blocks	232
TAAPH0 SDAF 230-Style Four-Bolt Pillow Blocks	233
TAAPH1 SDAF 231-Style Four-Bolt Pillow Blocks	234
TAAPG SN-Style Four-Bolt Pillow Blocks	235
TAASN 3000 Series Four-Bolt Pillow Block	237
TAASN 3100 Series Four-Bolt Pillow Block	239
DVC and DAAC Piloted Flange Cartridges	241
TACK and TAACK Piloted Flange Cartridges	243
T AFC and TAAFC Square Piloted Flange Cartridges	245
TAFB and TAAFB Square Flange Blocks	246
TAFNL and TAAFNL Series Square Flange Blocks	247
DVF and DAAF Square Flange Blocks	248
TAFK and TAAFK 9000 Series Square Flange Blocks	250
TAMC and TAAMC Cartridge Blocks	251

TA/DV TAA/DAA SERIES

TA/TAA SERIES

TA series mounted bearings are a direct drop-in replacement for SAF/SN split-cap housing dimensions.

DV/DAA SERIES

DV series mounted bearings are a drop-in replacement for common American set screw mounted bearings.



Fig. 50. TA/DV series taper adapter insert.



Fig. 51. Double nut tapered adapter insert.

YOU HAVE CHOICES

For the TA/TAA and DV/DAA series, you can select from many seal options and housing styles, which are shown on page 15.

HOUSINGS

- Two-bolt pillow blocks
- Four-bolt pillow blocks
- Flange blocks
- Piloted flange cartridges
- Cartridge blocks

SEALS

- Labyrinth: DuPont™ Teflon® (T)
- Triple-lip: nitrile rubber (M), urethane (O) and Viton® (N)
- Double-lip: nitrile rubber (B) and Viton (C)
- Steel and urethane closed-end covers (CS)
- Steel and urethane open-end covers (CK) with:
 - DuPont Teflon (T)
 - Triple-lip seal (DR)
 - V-ring seal (VR)

DVP AND DAAP TWO-BOLT PILLOW BLOCKS

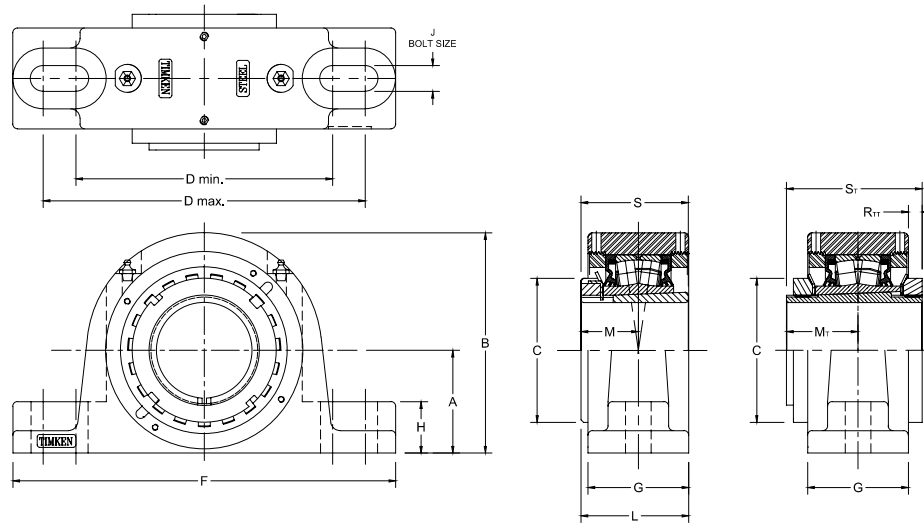

Bearing Part No.	Shaft Dia.	Bearing No.	A	B	C	D min.	D max.	F	G	H	J	L	M	M _T	R _{TT}	S	S _T	Wt.
			mm in.	mm in.	mm in.	mm in.	mm in.	mm in.	mm in.	mm in.	mm in.	mm in.	mm in.	mm in.	mm in.	mm in.	mm in.	mm in.
DVP09K107S DAAP09K107S	1 7/8 in.	22209	47.8 1.88	98.6 3.88	65.0 2.56	119.1 4.69	152.4 6.00	174.8 6.88	53.3 2.10	25.4 1.00	12 1/2	57.4 2.26	30.7 1.21			50.3 1.98		4.5 10
DVP09K108S DAAP09K108S	1 1/2 in.	22209	54.1 2.13	104.9 4.13	65.0 2.56	119.1 4.69	165.1 6.50	200.2 7.88	53.3 2.10	25.4 1.00	12 1/2	57.4 2.26	30.7 1.21	34.2 1.34	4.5 0.18	50.3 1.98	65.33 2.57	4.5 10
DVP09K040S DAAP09K040S	40 mm																	
DVP10K111S DAAP10K111S	1 11/16 in.	22210	54.1 2.13	114.3 4.50	70.1 2.76	144.8 5.70	165.1 6.50	200.2 7.88	54.9 2.16	31.8 1.25	12 1/2	61.0 2.40	33.5 1.32			55.1 2.17		5.0 11
DVP10K112S DAAP10K112S	1 3/4 in.	22210	57.2 2.25	117.3 4.62	70.1 2.76	158.8 6.25	180.8 7.12	225.6 8.88	54.9 2.16	31.8 1.25	16 5/8	61.0 2.40	33.5 1.32	37.6 1.48	6.3 0.25	55.1 2.17	71.33 2.81	5.0 11
DVP10K045S DAAP10K045S	45 mm																	
DVP11K115S DAAP11K115S	1 15/16 in.	22211	57.2 2.25	123.4 4.86	74.9 2.95	152.4 6.00	181.1 7.13	225.6 8.88	61.7 2.43	31.8 1.25	16 5/8	66.5 2.62	35.6 1.40	39.1 1.54	6.4 0.25	58.9 2.32	76.33 3.01	5.9 13
DVP11K050S DAAP11K050S	50 mm																	
DVP13K203S DAAP13K203S	2 3/8 in.	22213	63.5 2.50	138.9 5.47	85.1 3.35	165.1 6.50	200.0 7.87	244.6 9.63	70.6 2.78	32.8 1.29	16 5/8	74.9 2.95	39.6 1.56	43.7 1.72	3.8 0.15	65.0 2.56	82.83 3.26	9.1 20
DVP13K060S DAAP13K060S	60 mm																	
DVP15K207S DAAP15K207S	2 7/8 in.	22215	69.9 2.75	149.9 5.90	98.0 3.86	174.8 6.88	219.2 8.63	260.4 10.25	68.6 2.70	35.1 1.38	16 5/8	78.2 3.08	43.9 1.73	48.7 1.92	9.3 0.37	73.4 2.89	92.33 3.64	11.3 25
DVP15K065S DAAP15K065S	65 mm																	
DVP17K215S DAAP17K215S	2 15/16 in.	22217	82.6 3.25	173.2 6.82	110.0 4.33	200.2 7.88	244.3 9.62	295.4 11.63	76.2 3.00	35.1 1.38	20 3/4	88.1 3.47	49.8 1.96	50.2 1.98	16.0 0.63	82.0 3.23	104.33 4.12	14.5 32
DVP17K075S DAAP17K075S	75 mm																	
DVP20K307S DAAP20K307S	3 7/8 in.	22220	95.3 3.75	202.7 7.98	130.0 5.12	238.3 9.38	285.8 11.25	342.9 13.50	85.9 3.38	47.8 1.88	24 7/8	101.3 3.99	58.4 2.30	63.6 2.51	15.3 0.60	97.0 3.82	121.83 4.80	25.9 57
DVP20K090S DAAP20K090S	90 mm																	
DVP22K315S DAAP22K315S	3 15/16 in.	22222	108.0 4.25	223.5 8.80	145.0 5.71	255.5 10.06	317.5 12.50	362.0 14.25	100.6 3.96	38.1 1.50	24 1	113.3 4.46	63.0 2.48	65.8 2.59	14.6 0.57	104.9 4.13	130.7 5.15	30.4 67
DVP22K400S DAAP22K400S	4 in.																	
DVP22K100S DAAP22K100S	100 mm																	

TAPA AND TAAPA SAF-STYLE TWO-BOLT PILLOW BLOCKS

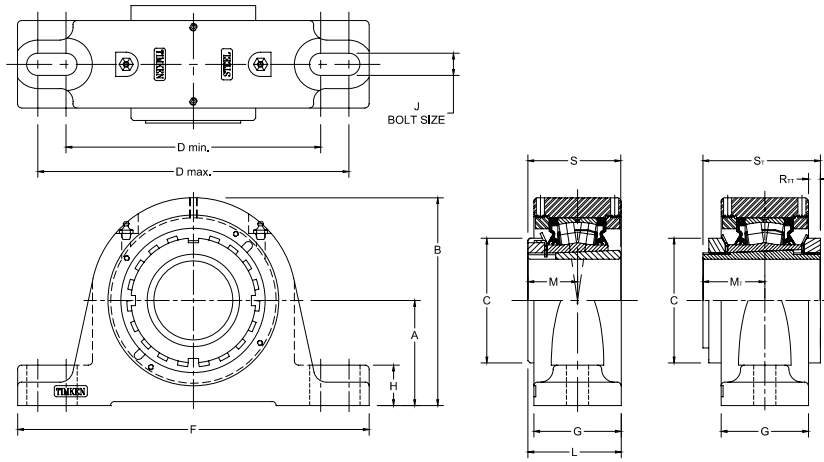

Bearing Part No.	Shaft Dia.	Bearing No.	A	B	C	D min.	D max.	F	G	H	J	L	M	M _T	R _T	S	S _T	Wt.
	mm in.		mm in.	mm in.	mm in.	mm in.	mm in.	mm in.	mm in.	mm in.	mm in.	mm in.	mm in.	mm in.	mm in.	mm in.	mm in.	kg lbs.
TAPA09K107S TAAPA09K107S	1 1/8 in.	22209	57.2	108.0	65.0	158.8	177.8	209.6	53.3	29.0	12	57.4	30.7	34.2	4.6	50.3	65.33	4.5
TAPA09K108S TAAPA09K108S	1 1/2 in.		2.25	4.25	2.56	6.25	7.00	8.25	2.10	1.14	1/2	2.26	1.21	1.34	0.18	1.98	2.57	10
TAPA09K040S TAAPA09K040S	40 mm																	
TAPA10K111S TAAPA10K111S	1 11/16 in.	22210	63.5	123.7	70.1	165.1	177.8	209.6	54.9	31.8	12	61.0	33.5	37.6	6.3	55.1	71.33	5.9
TAPA10K112S TAAPA10K112S	1 3/4 in.		2.50	4.87	2.76	6.50	7.00	8.25	2.16	1.25	1/2	2.40	1.32	1.48	0.25	2.17	2.81	13
TAPA10K045S TAAPA10K045S	45 mm																	
TAPA11K115S TAAPA11K115S	1 15/16 in.	22211	69.9	135.4	74.9	165.1	221.0	251.0	60.5	31.8	16	65.8	35.6	39.1	7.0	58.9	76.33	7.7
TAPA11K200S TAAPA11K200S	2 in.		2.75	5.33	2.95	6.50	8.70	9.88	2.38	1.25	5/8	2.59	1.40	1.54	0.27	2.32	3.01	17
TAPA11K050S TAAPA11K050S	50 mm																	
TAPA13K203S TAAPA13K203S	2 3/8 in.	22213	76.2	151.1	85.1	182.9	241.3	269.5	68.6	31.2	16	73.9	39.6	43.7	4.8	65.0	82.83	10.4
TAPA13K204S TAAPA13K204S	2 1/4 in.		3.00	5.95	3.35	7.20	9.50	10.61	2.70	1.23	5/8	2.91	1.56	1.72	0.19	2.56	3.26	23
TAPA13K060S TAAPA13K060S	60 mm																	
TAPA15K207S TAAPA15K207S	2 7/16 in.	22215	82.6	163.3	98.0	200.2	244.6	276.4	68.6	31.8	16	78.2	43.9	48.7	9.3	72.9	92.33	12.2
TAPA15K208S TAAPA15K208S	2 1/2 in.		3.25	6.43	3.86	7.88	9.63	10.88	2.70	1.25	5/8	3.08	1.73	1.92	0.37	2.87	3.64	27
TAPA15K065S TAAPA15K065S	65 mm																	
TAPA16K211S TAAPA16K211S	2 11/16 in.	22216	88.9	176.7	104.7	228.6	279.4	330.2	72.6	31.8	20	83.8	47.5	51.7	11.3	77.8	99.33	13.6
TAPA16K212S TAAPA16K212S	2 3/4 in.		3.50	6.96	4.12	9.00	11.00	13.00	2.86	1.25	3/4	3.30	1.87	2.04	0.45	3.06	3.91	30
TAPA16K070S TAAPA16K070S	70 mm																	

TAPA AND TAAPA SAF-STYLE TWO-BOLT PILLOW BLOCKS

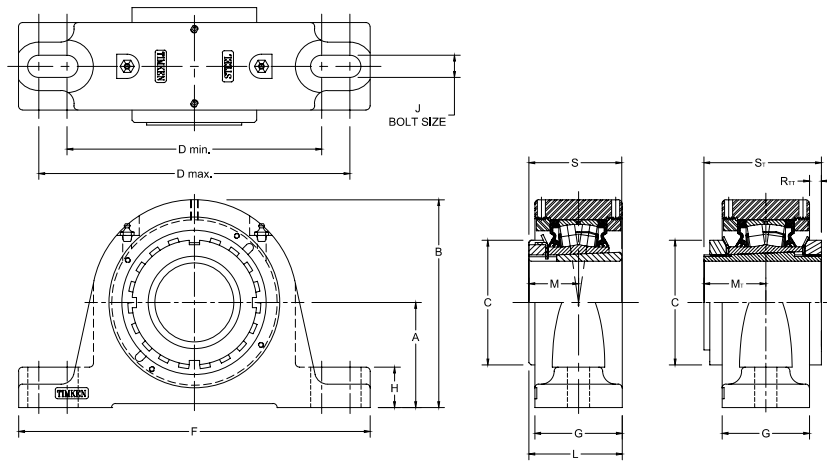

Bearing Part No.	Shaft Dia.	Bearing No.	A	B	C	D min.	D max.	F	G	H	J	L	M	M _T	R _T	S	S _T	Wt.	
			mm in.	mm in.	mm in.	mm in.	mm in.	mm in.	mm in.	mm in.	mm in.	mm in.	mm in.	mm in.	mm in.	mm in.	mm in.	mm in.	mm in.
TAPA17K215S TAAPA17K215S	2 1/16 in.	22217	95.3 3.75	185.9 7.32	110.0 4.33	241.3 9.50	279.4 11.00	320.8 12.63	76.2 3.00	33.8 1.33	20 3/4	88.1 3.47	49.8 1.96	50.2 1.98	16.0 0.63	82.0 3.23	104.33 4.12	15.0 33	
TAPA17K300S TAAPA17K300S	3 in.																		
TAPA17K075S TAAPA17K075S	75 mm																		
TAPA18K303S TAAPA18K303S	3 3/8 in.	22218	101.6 4.00	203.1 8.00	119.6 4.71	254.0 10.00	298.5 11.75	349.3 13.75	79.8 3.14	41.3 1.63	20 3/4	91.9 3.62	52.0 2.05	56.6 2.23	12.3 0.49	86.0 3.39	108.83 4.28	22.2 49	
TAPA18K304S TAAPA18K304S	3 1/4 in.																		
TAPA18K080S TAAPA18K080S	80 mm																		
TAPA20K307S TAAPA20K307S	3 7/8 in.	22220	114.3 4.50	219.2 8.63	130.0 5.12	276.4 10.88	333.5 13.13	374.7 14.75	86.9 3.42	41.4 1.63	24 7/8	102.4 4.03	58.4 2.30	63.6 2.51	14.8 0.58	97.0 3.82	121.83 4.80	29.5 65	
TAPA20K308S TAAPA20K308S	3 1/2 in.																		
TAPA20K090S TAAPA20K090S	90 mm																		
TAPA22K315S TAAPA22K315S	3 15/16 in.	22222	125.5 4.94	240.5 9.47	145.0 5.71	317.5 12.50	368.3 14.50	406.4 16.00	100.6 3.96	50.8 2.00	24 7/8	113.5 4.47	63.0 2.48	65.8 2.59	14.6 0.57	104.9 4.13	130.7 5.15	38.1 84	
TAPA22K400S TAAPA22K400S	4 in.																		
TAPA22K100S TAAPA22K100S	100 mm																		
TAPA26K407S TAAPA26K407S	4 7/16 in.	22226	152.4 6.00	284.0 11.18	165.1 6.50	362.0 14.25	400.1 15.75	444.5 17.50	128.0 5.04	51.8 2.04	24 1	135.9 5.35	71.9 2.83	76.6 3.01	9.1 0.36	120.9 4.76	149.65 5.89	61.7 136	
TAPA26K408S TAAPA26K408S	4 1/2 in.																		
TAPA26K115S TAAPA26K115S	115 mm																		
TAPA28K415S TAAPA28K415S	4 15/16 in.	22228	152.4 6.00	297.2 11.7	180.1 7.09	384.3 15.13	441.3 17.38	499.9 19.68	108.0 4.25	51.8 2.04	30 1 1/4	120.4 4.74	77.5 3.05	85.2 3.35	22.0 0.86	131.1 5.16	161.15 6.34	61.8 136	
TAPA28K500S TAAPA28K500S	5 in.																		
TAPA28K125S TAAPA28K125S	125 mm																		

TAPN AND TAAPN SN-STYLE TWO-BOLT PILLOW BLOCKS

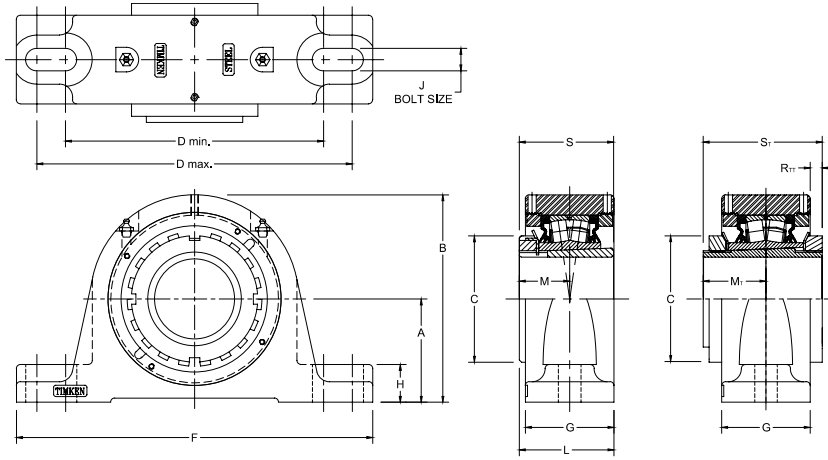

Bearing Part No. ⁽¹⁾	Shaft Dia.	Bearing No.	A	B	C	D min.	D max.	F	G	H	J	L	M	M _T	R _{TT}	S	S _T	Wt.	
	mm in.		mm in.	mm in.	mm in.	mm in.	mm in.	mm in.	mm in.	mm in.	mm in.	mm in.	mm in.	mm in.	mm in.	mm in.	mm in.	kg lbs.	
TAPN09K107S TAAPN09K107S	1 7/8 in.	22209	60.0 2.362	108.0 4.25	65.0 2.56	158.8 6.25	177.8 7.00	209.6 8.25	53.3 2.10	29.0 1.14	12 1/2	57.4 2.26	30.7 1.21	34.2 1.34	4.6 0.18	50.3 1.98	65.33 2.57	4.5 10	
TAPN09K108S TAAPN09K108S	1 1/2 in.																		
TAPN09K040S TAAPN09K040S	40 mm																		
TAPN10K111S TAAPN10K111S	1 1/16 in.	22210	60.0 2.362	120.1 4.73	70.1 2.76	165.1 6.50	177.8 7.00	209.6 8.25	54.9 2.16	28.2 1.11	12 1/2	61.0 2.40	33.5 1.32	37.6 1.48	6.3 0.25	55.1 2.17	71.33 2.81	5.9 13	
TAPN10K112S TAAPN10K112S	1 3/4 in.																		
TAPN10K045S TAAPN10K045S	45 mm																		
TAPN11K115S TAAPN11K115S	1 5/8 in.	22211	69.9 2.75	135.4 5.33	74.9 2.95	165.1 6.50	221.0 8.70	251.0 9.88	60.5 2.38	31.8 1.25	16 5/8	65.8 2.59	35.6 1.40	39.1 1.54	7.0 0.27	58.9 2.32	76.33 3.01	7.7 17	
TAPN11K200S TAAPN11K200S	2 in.																		
TAPN11K050S TAAPN11K050S	50 mm																		
TAPN12K055S TAAPN12K055S	55 mm	22212	70.0 2.756	140.5 5.53	79.8 3.14	177.8 7.00	219.2 8.63	254.0 10.00	60.5 2.38	31.8 1.25	16 5/8	67.6 2.66	37.6 1.48	41.1 1.62	7.0 0.27	62.0 2.44	78.33 3.08	9.1 20	
TAPN13K203S TAAPN13K203S	2 3/8 in.	22213	80.0 3.15	154.9 6.10	85.1 3.35	182.9 7.20	241.3 9.50	269.5 10.61	68.6 2.70	35.1 1.38	16 5/8	73.9 2.91	39.6 1.56	43.7 1.72	4.8 0.19	65.0 2.56	82.83 3.26	10.4 23	
TAPN13K204S TAAPN13K204S	2 1/4 in.																		
TAPN13K060S TAAPN13K060S	60 mm																		
TAPN15K207S TAAPN15K207S	2 7/16 in.	22215	80.0 3.15	160.8 6.33	98.0 3.86	200.2 7.88	244.6 9.63	276.4 10.88	68.6 2.70	29.2 1.15	16 5/8	78.2 3.08	43.9 1.73	48.7 1.92	9.3 0.37	72.9 2.87	92.33 3.64	12.2 27	
TAPN15K208S TAAPN15K208S	2 1/2 in.																		
TAPN15K065S TAAPN15K065S	65 mm																		
TAPN16K211S TAAPN16K211S	2 11/16 in.	22216	95.0 3.74	180.3 7.10	104.6 4.12	235.0 9.25	266.7 10.50	315.0 12.40	72.6 2.86	31.8 1.25	20 3/4	83.8 3.30	47.5 1.87	51.7 2.04	11.3 0.45	78.0 3.07	99.33 3.91	13.6 30	
TAPN16K212S TAAPN16K212S	2 3/4 in.																		
TAPN16K070S TAAPN16K070S	70 mm																		
TAPN17K215S TAAPN17K215S	2 15/16 in.	22217	95.3 3.75	185.9 7.32	110.0 4.33	241.3 9.50	279.4 11.00	320.8 12.63	76.2 3.00	33.8 1.33	20 3/4	88.1 3.47	49.8 1.96	50.2 1.98	16.0 0.63	82.0 3.23	104.33 4.12	15.0 33	
TAPN17K300S TAAPN17K300S	3 in.																		
TAPN17K075S TAAPN17K075S	75 mm																		

⁽¹⁾Double-nut (TAA/DAA) part number shown. Single-nut (TA/DV) version available upon request.

TAPN AND TAAPN SN-STYLE TWO-BOLT PILLOW BLOCKS

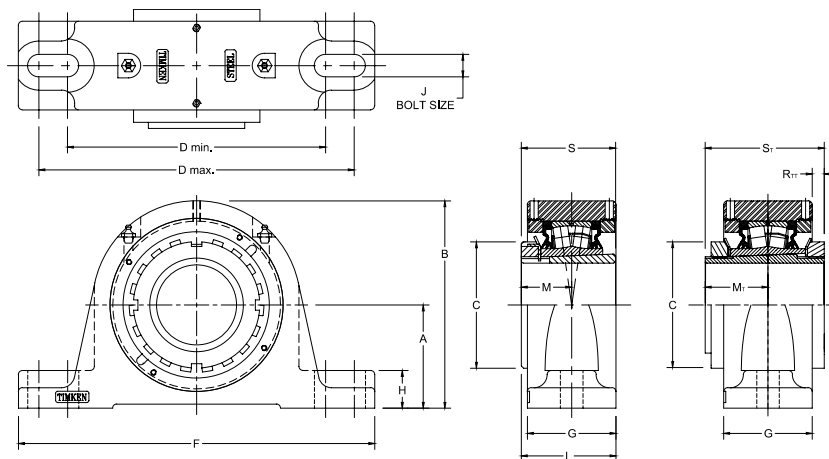

Bearing Part No. ⁽¹⁾	Shaft Dia.	Bearing No.	A	B	C	D min.	D max.	F	G	H	J	L	M	M _T	R _T	S	S _T	Wt.	
			mm in.	mm in.	mm in.	mm in.	mm in.	mm in.	mm in.	mm in.	mm in.	mm in.	mm in.	mm in.	mm in.	mm in.	mm in.	mm in.	mm in.
TAPN18K080S TAAPN18K080S	80 mm	22218	100.0 3.937	195.3 7.69	119.6 4.71	285.8 11.25	295.4 11.63	346.2 13.63	79.8 3.14	38.9 1.53	20 ¾	91.7 3.61	52.1 2.05	56.6 2.23	12.3 0.49	86.1 3.39	108.83 4.28	22.2 49	
TAPN18K303S TAAPN18K303S	3 ¾ in.																		
TAPN18K304S TAAPN18K304S	3 ¼ in.																		
TAPN19K085S TAAPN19K085S	85 mm	22219	112.0 4.409	212.3 8.36	124.7 4.91	285.8 11.25	295.4 11.63	346.2 13.63	82.8 3.26	38.9 1.53	20 ¾	96.0 3.78	54.6 2.15	59.2 2.33	13.2 0.52	89.9 3.54	113.83 4.48	23.1 51	
TAPN20K307S TAAPN20K307S	3 7/16 in.	22220	112.0 4.409	216.9 8.54	130.0 5.12	276.4 10.88	333.5 13.13	374.7 14.75	86.9 3.42	38.9 1.53	24 7/8	102.4 4.03	58.4 2.30	63.6 2.51	14.8 0.58	97.0 3.82	121.83 4.80	29.5 65	
TAPN20K308S TAAPN20K308S	3 ½ in.																		
TAPN20K090S TAAPN20K090S	90 mm	22222	125.0 4.921	240.5 9.47	145.0 5.71	317.5 12.50	368.3 14.50	406.4 16.00	100.6 3.96	50.8 2.00	24 7/8	113.5 4.47	63.0 2.48	65.8 2.59	14.6 0.57	104.9 4.13	130.7 5.15	38.1 84	
TAPN22K315S TAAPN22K315S	3 15/16 in.																		
TAPN22K400S TAAPN22K400S	4 in.																		
TAPN22K100S TAAPN22K100S	100 mm	22224	140.0 5.512	262.9 10.35	154.4 6.08	344.4 13.56	355.6 14.00	409.7 16.13	97.8 3.85	50.8 2.00	24 7/8	116.1 4.57	67.1 2.64	71.6 2.82	18.7 0.73	112.0 4.41	139.15 5.48	49.9 110	
TAPN24K403S TAAPN24K403S	4 3/16 in.																		
TAPN24K404S TAAPN24K404S	4 ¼ in.																		
TAPN24K110S TAAPN24K110S	110 mm	22226	150.0 5.906	281.7 11.09	165.1 6.50	367.3 14.46	400.1 15.75	444.5 17.50	128.0 5.04	49.3 1.94	24 1	135.9 5.35	71.9 2.83	76.6 3.01	9.1 0.36	120.9 4.76	149.65 5.89	61.7 136	
TAPN26K407S TAAPN26K407S	4 7/16 in.																		
TAPN26K408S TAAPN26K408S	4 ½ in.																		
TAPN26K115S TAAPN26K115S	115 mm	22228	150.0 5.906	288.5 11.36	180.1 7.09	384.3 15.13	441.5 17.38	499.9 19.68	108.0 4.25	49.3 1.94	30 1 ¼	120.4 4.74	77.5 3.05	85.2 3.35	22.0 0.86	131.1 5.16	161.15 6.34	61.8 136	
TAPN28K415S TAAPN28K415S	4 15/16 in.																		
TAPN28K500S TAAPN28K500S	5 in.																		
TAPN28K125S TAAPN28K125S	125 mm																		

⁽¹⁾Double-nut (TAA/DAA) part number shown. Single-nut (TA/DV) version available upon request.

TASD AND TAASD SPECIAL DUTY-STYLE TWO-BOLT PILLOW BLOCKS

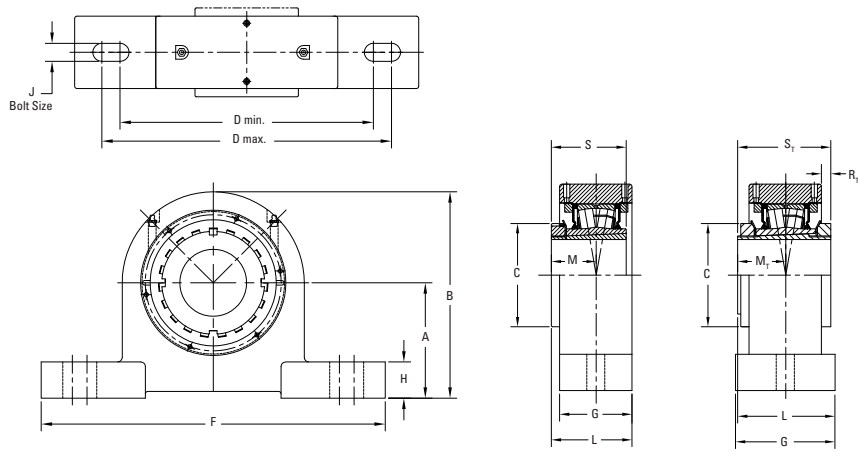

Bearing Part No. ⁽¹⁾	Shaft Dia.	Bearing No.	A	B	C	D min.	D max.	F	G	H	J	L	M	M _T	R _{TT}	S	S _T	Wt.
	mm in.		mm in.	mm in.	mm in.	mm in.	mm in.	mm in.	mm in.	mm in.	mm in.	mm in.	mm in.	mm in.	mm in.	mm in.	mm in.	kg lbs.
TASD09K107S TAASD09K107S	1 7/8 in.	22209	73.2	124.0	65.0	174.8	193.8	228.6	51.7	29.0	M12	56.6	30.7	33.3	6.20	50.2	65.3	6
TASD09K108S TAASD09K108S	1 1/2 in.		73.2	124.0	65.0	174.8	193.8	228.6	51.7	29.0	M12	56.6	30.7	33.3	6.20	50.2	65.3	6
TASD09K040S TAASD09K040S	40 mm		73.2	124.0	65.0	174.8	193.8	228.6	51.7	29.0	M12	56.6	30.7	33.3	6.20	50.2	65.3	6
TASD10K111S TAASD10K111S	1 11/16 in.	22210	79.5	139.7	70.1	192.0	201.7	241.3	51.7	31.8	M12	59.4	33.5	36.3	9.20	55.0	71.3	7
TASD10K112S TAASD10K112S	1 3/4 in.		79.5	139.7	70.1	192.0	201.7	241.3	51.7	31.8	M12	59.4	33.5	36.3	9.20	55.0	71.3	7
TASD10K045S TAASD10K045S	45 mm		79.5	139.7	70.1	192.0	201.7	241.3	51.7	31.8	M12	59.4	33.5	36.3	9.20	55.0	71.3	7
TASD11K115S TAASD11K115S	1 5/8 in.	22211	82.6	148.1	74.9	209.6	235.0	279.4	57.5	31.8	M16	64.3	35.6	39.4	8.20	58.9	76.3	9
TASD11K200S TAASD11K200S	2 in.		82.6	148.1	74.9	209.6	235.0	279.4	57.5	31.8	M16	64.3	35.6	39.4	8.20	58.9	76.3	9
TASD11K050S TAASD11K050S	50 mm		82.6	148.1	74.9	209.6	235.0	279.4	57.5	31.8	M16	64.3	35.6	39.4	8.20	58.9	76.3	9
TASD13K203S TAASD13K203S	2 3/8 in.	22213	95.3	170.2	85.1	231.9	263.7	304.8	70.7	31.8	M16	75.0	39.6	42.4	5.10	65.0	82.8	13
TASD13K204S TAASD13K204S	2 1/4 in.		95.3	170.2	85.1	231.9	263.7	304.8	70.7	31.8	M16	75.0	39.6	42.4	5.10	65.0	82.8	13
TASD13K060S TAASD13K060S	60 mm		95.3	170.2	85.1	231.9	263.7	304.8	70.7	31.8	M16	75.0	39.6	42.4	5.10	65.0	82.8	13
TASD15K207S TAASD15K207S	2 7/8 in.	22215	101.6	182.4	98.0	254.0	292.1	336.6	70.7	31.8	M20	79.3	43.9	47.0	10.0	72.9	92.3	15
TASD15K208S TAASD15K208S	2 1/2 in.		101.6	182.4	98.0	254.0	292.1	336.6	70.7	31.8	M20	79.3	43.9	47.0	10.0	72.9	92.3	15
TASD15K065S TAASD15K065S	65 mm		101.6	182.4	98.0	254.0	292.1	336.6	70.7	31.8	M20	79.3	43.9	47.0	10.0	72.9	92.3	15
TASD17K215S TAASD17K215S	2 15/16 in.	22217	120.7	211.3	110.0	279.4	317.5	362.0	75.7	39.6	M20	87.6	49.8	53.6	12.9	82.0	104.3	22
TASD17K300S TAASD17K300S	3 in.		120.7	211.3	110.0	279.4	317.5	362.0	75.7	39.6	M20	87.6	49.8	53.6	12.9	82.0	104.3	22
TASD17K075S TAASD17K075S	75 mm		120.7	211.3	110.0	279.4	317.5	362.0	75.7	39.6	M20	87.6	49.8	53.6	12.9	82.0	104.3	22
TASD18K080S TAASD18K080S	80 mm	22218	139.7	237.5	119.6	336.6	362.0	425.5	79.7	39.6	M24	91.9	52.1	56.1	12.9	86.1	108.8	28
TASD18K303S TAASD18K303S	3 3/8 in.		139.7	237.5	119.6	336.6	362.0	425.5	79.7	39.6	M24	91.9	52.1	56.1	12.9	86.1	108.8	28
TASD18K304S TAASD18K304S	3 1/4 in.		139.7	237.5	119.6	336.6	362.0	425.5	79.7	39.6	M24	91.9	52.1	56.1	12.9	86.1	108.8	28
TASD20K307S TAASD20K307S	3 7/8 in.	22220	139.7	247.7	130.0	336.6	362.0	425.5	85.7	69.9	M24	101.3	58.4	62.6	16.4	97.0	121.8	33
TASD20K308S TAASD20K308S	3 1/2 in.		139.7	247.7	130.0	336.6	362.0	425.5	85.7	69.9	M24	101.3	58.4	62.6	16.4	97.0	121.8	33
TASD20K090S TAASD20K090S	90 mm		139.7	247.7	130.0	336.6	362.0	425.5	85.7	69.9	M24	101.3	58.4	62.6	16.4	97.0	121.8	33

⁽¹⁾ Double-nut (TAA) part number shown. Single-nut (TA) version available upon request.

TADI AND TAADI DI-STYLE TWO-BOLT PILLOW BLOCK

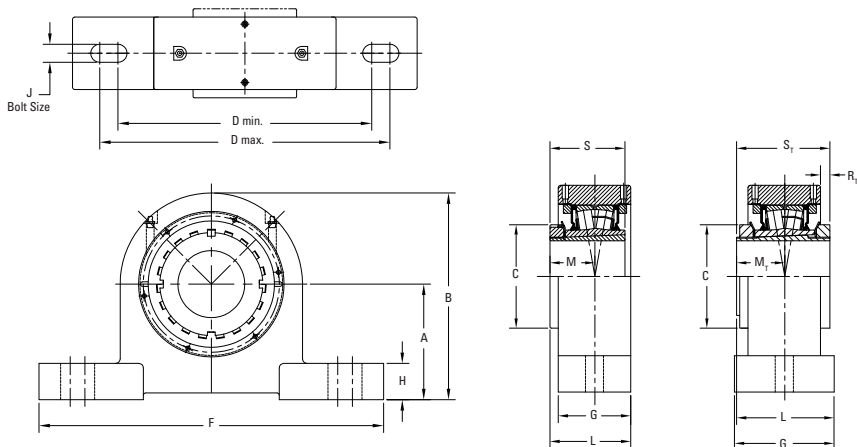

Bearing Part No.	Shaft Dia.	Bearing No.	A	B	C	D min.	D max.	F	G	H	J	L	M	M _T	R _{TT}	S	S _T	Wt.
			mm in.	mm in.	mm in.	mm in.	mm in.	mm in.	mm in.	mm in.	mm in.	mm in.	mm in.	mm in.	mm in.	mm in.	mm in.	mm in.
TADI09K107S TAADI09K107S	1 7/8 in.	22209	60.5 2.38	119.8 4.72	65.0 2.56	158.8 6.25	168.4 6.63	203.2 8.00	51.7 2.03	29.0 1.14	M12 ½	56.6 2.23	30.7 1.21	33.3 1.31	6.20 0.24	50.3 1.98	65.3 2.42	5 12
TADI09K108S TAADI09K108S	1 ½ in.		66.8 2.63	127.0 5.00	65.0 2.56	174.8 6.88	193.8 7.63	228.6 9.00	51.7 2.03	31.8 1.25	M12 ½	56.6 2.23	30.7 1.21			50.3 1.98		
TADI09K040S TAADI09K040S	40 mm		66.8 2.63	127.0 5.00	70.1 2.76	174.8 6.88	193.8 7.63	228.6 9.00	51.7 2.03	31.8 1.25	M12 ½	62.1 2.45	33.5 1.32	36.3 1.43	9.2 0.36	55.1 2.17	71.3 2.64	6 13
TADI10K111S TAADI10K111S	1 11/16 in.		73.2 2.88	138.7 5.46	70.1 2.76	187.5 7.38	201.7 7.94	254.0 10.00	51.7 2.03	31.8 1.25	M12 ½	65.3 2.57	33.5 1.32			55.1 2.17		
TADI10K112S TAADI10K112S	1 ¾ in.	22211	73.2 2.88	138.7 5.46	74.9 2.95	187.5 7.38	201.7 7.94	254.0 10.00	57.5 2.26	31.8 1.25	M16 5/8	64.3 2.53	35.6 1.40	39.4 1.55	8.2 0.32	58.9 2.32	76.3 2.80	7 16
TADI10K045S TAADI10K045S	45 mm		73.2 2.88	138.7 5.46	74.9 2.95	187.5 7.38	201.7 7.94	254.0 10.00	57.5 2.26	31.8 1.25	M16 5/8	64.3 2.53	35.6 1.40	39.4 1.55		58.9 2.32		
TADI11K115S TAADI11K115S	1 5/8 in.		76.2 3.00	151.1 5.95	85.1 3.35	203.2 8.00	235.0 9.25	279.4 11.00	70.71 2.78	31.8 1.25	M16 5/8	77.7 3.06	39.6 1.56	42.4 1.67	5.0 0.20	65.0 2.56	82.8 3.12	11 25
TADI11K050S TAADI11K050S	50 mm		82.6 3.25	163.3 6.43	85.1 3.35	235.0 9.25	260.4 10.25	304.8 12.00	70.71 2.78	31.8 1.25	M16 5/8	82.0 3.23	43.9 1.73			47.0 1.85		
TADI15K207S TAADI15K207S	2 7/8 in.	22215	82.6 3.25	163.3 6.43	98.0 3.86	235.0 9.25	260.4 10.25	304.8 12.00	70.71 2.78	31.8 1.25	M16 5/8	82.0 3.23	43.9 1.73	47.0 1.85	9.9 0.39	72.9 2.87	92.3 3.46	13 29
TADI15K208S TAADI15K208S	2 ½ in.		82.6 3.25	163.3 6.43	98.0 3.86	235.0 9.25	260.4 10.25	304.8 12.00	70.71 2.78	31.8 1.25	M16 5/8	82.0 3.23	43.9 1.73	47.0 1.85	9.9 0.39	72.9 2.87		
TADI15K065S TAADI15K065S	65 mm		95.3 3.75	185.9 7.32	110.0 4.33	251.0 9.88	292.1 11.50	341.8 13.46	75.7 2.98	31.8 1.25	M20 ¾	87.9 1.96	49.8 1.96	53.6 2.11	12.9 0.51	82.0 3.23	104.3 3.92	18 39
TADI17K215S TAADI17K215S	2 9/16 in.		95.3 3.75	185.9 7.32	110.0 4.33	251.0 9.88	292.1 11.50	341.8 13.46	75.7 2.98	31.8 1.25	M20 ¾	87.9 1.96	49.8 1.96	53.6 2.11	12.9 0.51	82.0 3.23		
TADI18K080S TAADI18K080S	80 mm	22218	114.3 4.50	219.2 8.63	119.6 4.71	325.4 12.81	350.8 13.81	406.4 16.00	79.7 3.14	39.6 1.56	M24 7/8	93.3 3.68	52.1 2.05	56.1 2.21	12.8 0.51	86.1 3.39	108.8 4.10	26 58
TADI18K303S TAADI18K303S	3 3/8 in.		114.3 4.50	219.2 8.63	119.6 4.71	325.4 12.81	350.8 13.81	406.4 16.00	79.7 3.14	39.6 1.56	M24 7/8	93.3 3.68	52.1 2.05	56.1 2.21	12.8 0.51	86.1 3.39		
TADI18K304S TAADI18K304S	3 ¼ in.		114.3 4.50	219.2 8.63	130.0 5.12	325.4 12.81	350.8 13.81	406.4 16.00	85.7 3.38	39.6 1.56	M24 7/8	102.9 4.05	58.4 2.30	58.4 2.30	16.3 0.64	97.0 3.82	121.8 4.60	27 60
TADI20K307S TAADI20K307S	3 7/8 in.		114.3 4.50	219.2 8.63	130.0 5.12	325.4 12.81	350.8 13.81	406.4 16.00	85.7 3.38	39.6 1.56	M24 7/8	102.9 4.05	58.4 2.30	58.4 2.30	16.3 0.64	97.0 3.82		
TADI20K308S TAADI20K308S	3 ½ in.	90 mm	114.3 4.50	219.2 8.63	130.0 5.12	325.4 12.81	350.8 13.81	406.4 16.00	85.7 3.38	39.6 1.56	M24 7/8	102.9 4.05	58.4 2.30	58.4 2.30	16.3 0.64	97.0 3.82	121.8 4.60	27 60
TADI20K090S TAADI20K090S	90 mm		114.3 4.50	219.2 8.63	130.0 5.12	325.4 12.81	350.8 13.81	406.4 16.00	85.7 3.38	39.6 1.56	M24 7/8	102.9 4.05	58.4 2.30	58.4 2.30	16.3 0.64	97.0 3.82	121.8 4.60	27 60

TAPKT AND TAAPKT 9000 SERIES TWO-BOLT PILLOW BLOCKS

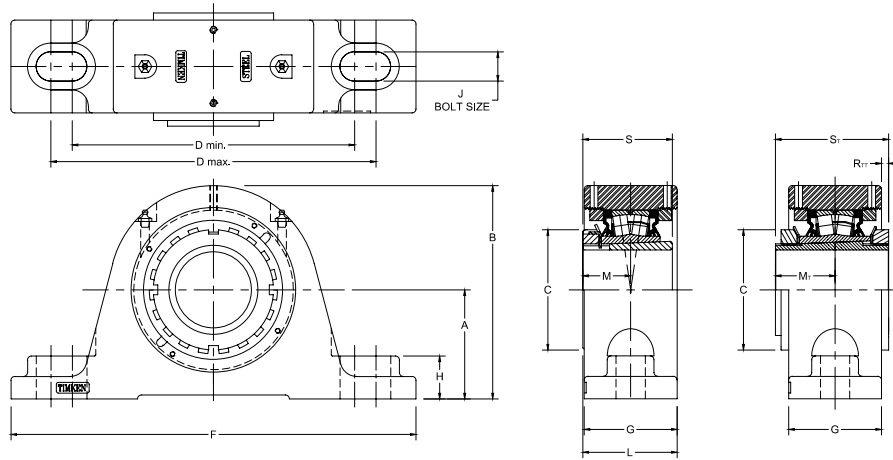

Bearing Part No.	Shaft Dia.	Bearing No.	A	B	C	D min.	D max.	F	G	H	J	L	M	M _T	R _{TT}	S	S _T	Wt.
	mm in.		mm in.	mm in.	mm in.	mm in.	mm in.	mm in.	mm in.	mm in.	mm in.	mm in.	mm in.	mm in.	mm in.	mm in.	mm in.	kg lbs.
TAPKT10K045S TAAPKT10K045S	45 mm	22210	69.9 2.75	133.4 5.25	70.1 2.67	176.3 6.94	204.7 8.06	260.4 10.25	54.9 2.16	41.4 1.63	16 5/8	61.0 2.4	33.5 1.32	37.6 1.48	6.4 0.25	55.1 2.17	71.3 2.81	3.65 8.02
TAPKT11K115S TAAPKT11K115S	1 15/16 in.	22211	69.9 2.75	133.4 5.25	74.9 2.95	176.3 6.94	204.7 8.06	260.4 10.25	61.8 2.43	41.4 1.63	16 5/8	66.4 2.62	35.6 1.40	39.1 1.54	6.6 0.26	58.9 2.32	76.3 3.01	3.92 8.63
TAPKT11K200S TAAPKT11K200S	2 in.	22211																
TAPKT11K050S TAAPKT11K050S	50 mm	22211	76.2 3.00	146.1 5.75	79.8 3.14	195.3 7.69	223.8 8.81	285.8 11.25	60.5 2.38	44.5 1.75	20 3/4	67.8 2.67	37.6 1.48	41.1 1.62	6.9 0.27	62.0 2.44	78.3 3.08	4.83 10.63
TAPKT12K055S TAAPKT12K055S	55 mm	22212																
TAPKT13K203S TAAPKT13K203S	2 3/8 in.	22213	76.2 3.00	153.7 6.05	85.1 3.35	194.6 7.66	223.0 8.78	285.8 11.25	73.7 2.90	35.1 1.38	20 3/4	76.5 3.01	36.6 1.56	43.7 1.72	2.3 0.09	65.0 2.56	82.83 3.26	10.0 22
TAPKT13K204S TAAPKT13K204S	2 1/4 in.																	
TAPKT13K060S TAAPKT13K060S	60 mm	22215	88.9 3.50	173.7 6.84	98.0 3.86	230.1 9.06	265.2 10.44	330.2 13.00	75.7 2.98	35.1 1.38	24 7/8	81.8 3.22	43.9 1.73	48.7 1.92	5.8 0.23	72.9 2.87	92.33 3.64	12.7 28
TAPKT15K207S TAAPKT15K207S	2 7/8 in.																	
TAPKT15K208S TAAPKT15K208S	2 1/2 in.	22215	88.9 3.50	173.7 6.84	98.0 3.86	230.1 9.06	265.2 10.44	330.2 13.00	75.7 2.98	35.1 1.38	24 7/8	81.8 3.22	43.9 1.73	48.7 1.92	5.8 0.23	72.9 2.87	92.33 3.64	12.7 28
TAPKT15K065S TAAPKT15K065S	65 mm																	

DVPF AND DAAPF FOUR-BOLT PILLOW BLOCKS

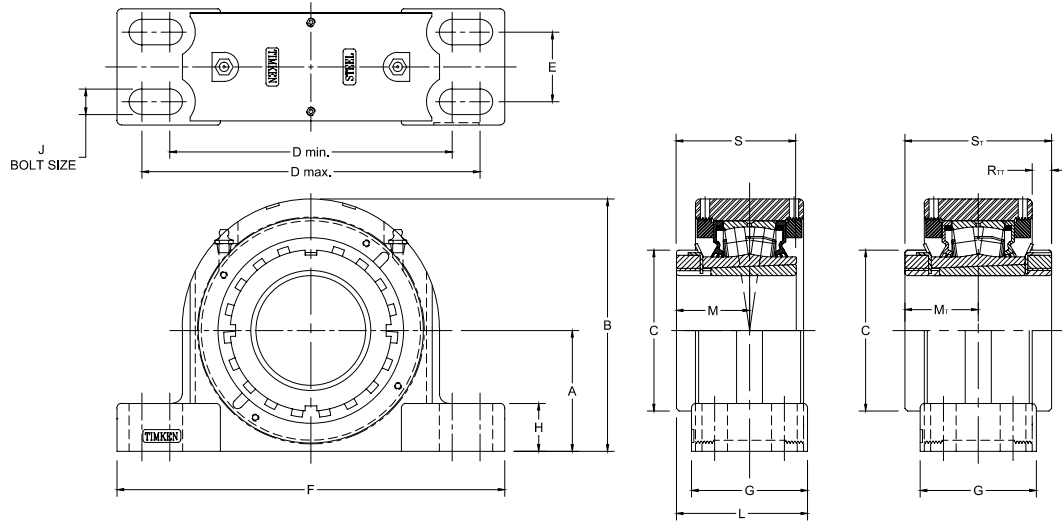

Bearing Part No.	Shaft Dia.	Bearing No.	A	B	C	D min.	D max.	E	F	G	H	J	L	M	M _T	R _T	S	S _T	Wt.	
	mm in.		mm in.	mm in.	mm in.	mm in.	mm in.	mm in.	mm in.	mm in.	mm in.	mm in.	mm in.	mm in.	mm in.	mm in.	mm in.	mm in.	kg lbs.	
DVPF17K215S DAAPF17K215S	2 1/16 in.	22217	82.6	172.5	110.0	193.0	231.1	47.8	265.2	79.5	32.8	16	86.6	49.8	50.2	13.2	82.0	104.33	23.1	
DVPF17K300S DAAPF17K300S	3 in.		3.25	6.79	4.33	7.60	9.10	1.88	10.44	3.13	1.29	5/8	3.41	1.96	1.98	0.52	3.23	4.12	51	
DVPF17K075S DAAPF17K075S	75 mm																			
DVPF20K307S DAAPF20K307S	3 7/16 in.	22220	95.3	200.2	130.0	225.6	276.4	50.8	312.4	95.3	39.6	20	101.3	58.4	63.6	13.8	97.0	121.83	31.8	
DVPF20K308S DAAPF20K308S	3 1/2 in.		3.75	7.88	5.12	8.88	10.88	2.00	12.30	3.75	1.56	3/4	3.99	2.30	2.51	0.54	3.82	4.80	70	
DVPF20K090S DAAPF20K090S	90 mm																			
DVPF22K315S DAAPF22K315S	3 15/16 in.	22222	108.0	223.0	145.0	276.4	339.9	57.2	378.0	109.5	35.6	20	110.7	63.0	65.8	17.3	104.9	130.7	38.6	
DVPF22K400S DAAPF22K400S	4 in.		4.25	8.78	5.71	10.88	13.38	2.25	14.88	4.31	1.40	3/4	4.36	2.48	2.59	0.68	4.13	5.15	85	
DVPF22K100S DAAPF22K100S	100 mm																			
DVPF26K407S DAAPF26K407S	4 7/16 in.	22226	120.7	250.7	165.1	302.3	368.3	63.5	409.7	120.7	40.1	20	123.7	71.9	76.6	16.7	120.1	149.65	62.1	
DVPF26K408S DAAPF26K408S	4 1/2 in.		4.75	9.87	6.50	11.90	14.50	2.50	16.13	4.75	1.58	3/4	4.87	2.83	3.01	0.66	4.73	5.89	137	
DVPF26K115S DAAPF26K115S	115 mm																			
DAAPF32K140S	140 mm	23132 ⁽¹⁾	169.9	330.3	210.0	441.3	489.0	95.3	558.8	171.5	76.2	24	176.2	N/A	90.5	11.9	N/A	185.0	122.4	
DAAPF32K506S	5 3/8 in.		6.69	13.00	8.27	17.38	19.25	3.75	22.00	6.75	3.00	1	6.94		3.56	0.47		7.28	270	
DAAPF32K507S	5 7/8 in.																			
DAAPF32K508S	5 1/2 in.																			
DAAPF34K150S	150 mm																			
DAAPF34K513S	5 13/16 in.	23134	169.9	330.3	219.4	441.3	485.8	95.3	558.8	171.5	76.2	24	179.1	N/A	93.4	10.8	N/A	186.7	132.9	
DAAPF34K514S	5 7/8 in.		6.69	13.00	8.64	17.38	19.13	3.75	22.00	6.75	3.00	1	7.05		3.68	0.42		7.35	293	
DAAPF34K515S	5 1/8 in.																			
DAAPF34K600S	6 in.																			
DAAPF36K160S	160 mm																			
DAAPF36K605S	6 5/16 in.	23136	160.5	391.2	230.0	530.2	600.1	117.5	660.4	190.5	76.2	24	194.2	N/A	98.9	14.5	N/A	196.7	157.1	
DAAPF36K606S	6 3/8 in.		7.50	15.40	9.06	20.88	23.63	4.63	26.00	7.50	3.00	1	7.65		3.90	0.57		7.74	346.4	
DAAPF36K607S	6 7/16 in.																			
DAAPF36K608S	6 1/2 in.																			
DAAPF38K170S	170 mm																			
DAAPF38K613S	6 13/16 in.	23138	160.5	391.2	241.7	530.2	600.1	117.5	660.4	190.5	76.2	24	200.0	N/A	104.8	11.4	N/A	206.7	170.7	
DAAPF38K614S	6 7/8 in.		7.50	15.40	9.51	20.88	23.63	4.63	26.00	7.50	3.00	1	7.88		4.13	0.45		8.14	376.3	
DAAPF38K615S	6 1/8 in.																			
DAAPF38K700S	7 in.																			

⁽¹⁾Insert size 23132K and above come standard with double nut tapered adapter.

TAPK AND TAAPK 9000 SERIES FOUR-BOLT PILLOW BLOCKS

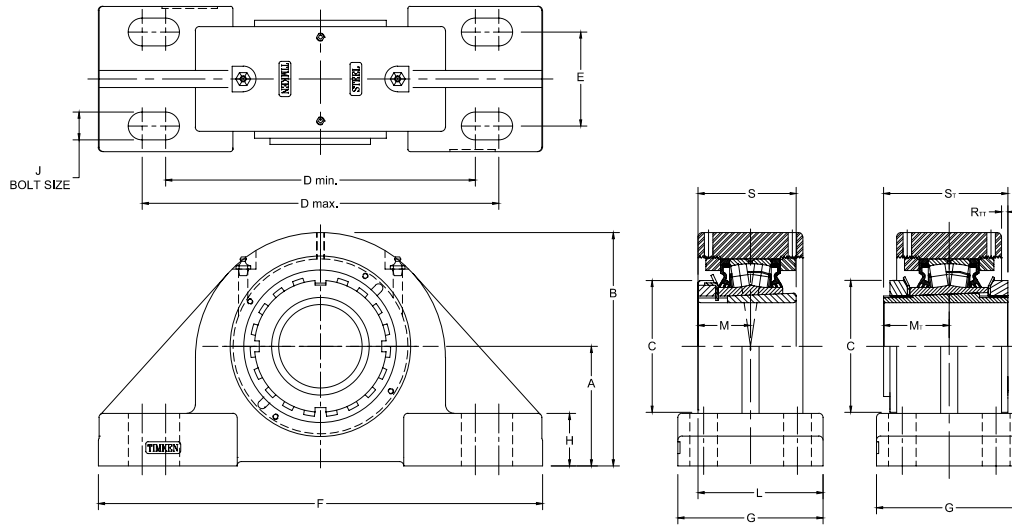

Bearing Part No.	Shaft Dia.	Bearing No.	A	B	C	D min.	D max.	E	F	G	H	J	L	M	M _T	R _{TT}	S	S _T	Wt.
	mm in.		mm in.	mm in.	mm in.	mm in.	mm in.	mm in.	mm in.	mm in.	mm in.	mm in.	mm in.	mm in.	mm in.	mm in.	mm in.	mm in.	kg lbs.
TAPK10K045S TAAPK10K045S	45 mm	22210	69.9 2.75	134.9 5.31	70.1 2.76	176.3 6.94	204.7 8.06	57.2 2.25	260.4 10.25	95.3 3.75	25.4 1.00	16 5/8	81.3 3.20	33.5 1.32	37.6 1.48	3.6 0.14	55.1 2.17	71.3 2.81	7.77 17.1
TAPK11K115S TAAPK11K115S	1 15/16 in.																		
TAPK11K200S TAAPK11K200S	2 in.	22211	69.9 2.75	134.9 5.31	74.9 2.95	176.3 6.94	204.7 8.06	57.2 2.25	260.4 10.25	95.3 3.75	25.4 1.00	16 5/8	85.9 3.38	35.6 1.4	39.1 1.54	7.1 0.28	58.9 2.32	76.3 3.01	7.77 17.1
TAPK11K050S TAAPK11K050S	50 mm																		
TAPK12K055S TAAPK12K055S	55 mm	22212	76.2 3.00	146.8 5.78	79.8 3.14	195.3 7.69	223.8 8.81	66.8 2.63	285.5 11.25	104.9 4.13	28.7 1.13	16 5/8	90.2 3.55	37.6 1.48	41.1 1.62	6.9 0.27	62.0 2.44	78.3 3.08	9.4 20.9
TAPK13K203S TAAPK13K203S	2 3/8 in.	22213	76.2 3.00	152.4 6.00	85.1 3.35	195.3 7.69	223.8 8.81	66.8 2.63	285.5 11.25	104.9 4.13	28.7 1.13	16 5/8	92.2 3.63	39.6 1.56	43.7 1.72	4.8 0.19	65.0 2.56	82.8 3.26	10.1 22.2
TAPK15K207S TAAPK15K207S	2 7/8 in.																		
TAPK15K208S TAAPK15K208S	2 1/2 in.	22215	88.9 3.50	173.5 6.83	98.0 3.86	230.1 9.06	265.2 10.44	69.9 2.75	330.2 13.00	108.0 4.25	39.1 1.54	20 3/4	98.0 3.86	43.9 1.73	48.7 1.92	4.7 0.18	72.9 2.87	92.33 3.64	13.2 29
TAPK15K065S TAAPK15K065S	65 mm																		
TAPK16K211S TAAPK16K211S	2 11/16 in.	22216	101.6 4.00	190.5 7.50	104.7 4.12	274.6 10.81	309.6 12.19	76.2 3.00	381.0 15.00	127.0 5.00	38.1 1.50	20 3/4	111.0 4.37	47.5 1.87	51.7 2.04	11.2 0.44	77.8 3.06	99.3 3.91	7.45 16.4
TAPK17K215S TAAPK17K215S	2 15/16 in.																		
TAPK17K300S TAAPK17K300S	3 in.	22217	101.6 4.00	201.2 7.92	110.0 4.33	274.6 10.81	309.6 12.19	76.2 3.00	381.0 15.00	120.7 4.75	38.1 1.50	20 3/4	110.2 4.34	49.8 1.96	50.2 1.98	9.7 0.38	82.0 3.23	104.33 4.12	16.8 37
TAPK17K075S TAAPK17K075S	75 mm																		
TAPK18K303S TAAPK18K303S	3 3/8 in.	22218	127.0 5.00	228.6 9.00	119.6 4.71	322.3 12.69	350.8 13.81	88.9 3.50	425.5 16.75	139.7 5.50	38.1 1.50	22 7/8	121.9 4.80	52.0 2.05	56.6 2.23	11.9 0.47	86.0 3.39	108.8 4.28	9.91 21.8
TAPK18K080S TAAPK18K080S	80 mm																		

TAPK AND TAAPK 9000 SERIES FOUR-BOLT PILLOW BLOCKS

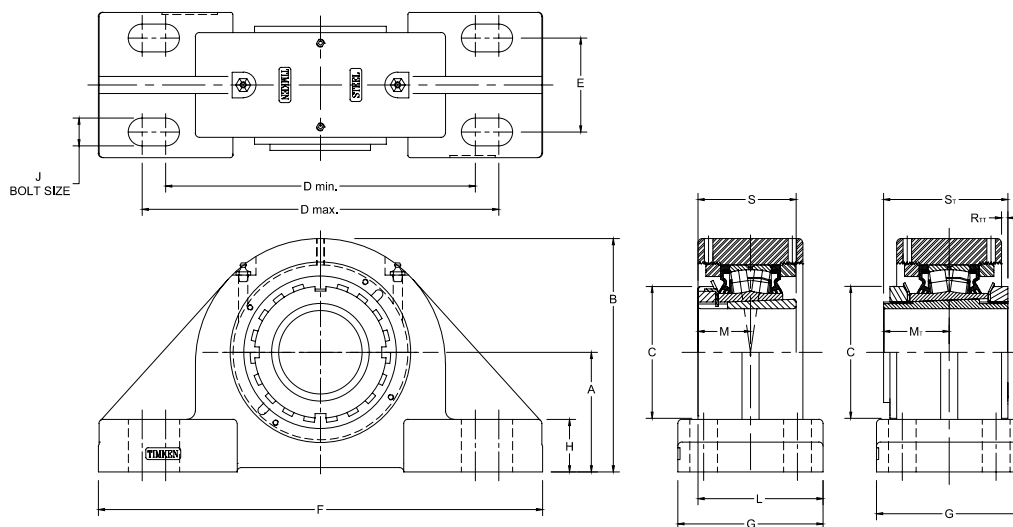

Bearing Part No.	Shaft Dia.	Bearing No.	A	B	C	D min.	D max.	E	F	G	H	J	L	M	M _T	R _T	S	S _T	Wt.	
	mm in.		mm in.	mm in.	mm in.	mm in.	mm in.	mm in.	mm in.	mm in.	mm in.	mm in.	mm in.	mm in.	mm in.	mm in.	mm in.	mm in.	mm in.	kg lbs.
TAPK20K307S TAAPK20K307S	3 7/8 in.	22220	127.0 5.00	239.8 9.44	130.0 5.12	317.5 12.50	355.6 14.00	88.9 3.50	425.5 16.75	139.7 5.50	41.4 1.63	22 7/8	128.3 5.05	58.4 2.30	63.6 2.51	8.4 0.33	97.0 3.82	121.83 4.80	31.8 70	
TAPK20K308S TAAPK20K308S	3 1/2 in.																			
TAPK20K090S TAAPK20K090S	90 mm																			
TAPK22K315S TAAPK22K315S	3 15/16 in.	22222	146.1 5.75	273.8 10.78	145.0 5.71	354.1 13.94	395.2 15.56	101.6 4.00	469.9 18.50	158.8 6.25	45.7 1.80	24 1	138.2 5.44	63.0 2.48	65.8 2.59	14.1 0.56	104.9 4.13	130.7 5.15	39.5 87	
TAPK22K400S TAAPK22K400S	4 in.																			
TAPK22K100S TAAPK22K100S	100 mm																			
TAPK24K403S TAAPK24K403S	4 3/8 in.	22224	155.7 6.13	289.1 11.38	154.4 6.08	387.4 15.25	425.5 16.75	108.0 4.25	514.4 20.25	158.8 6.25	47.8 1.88	24 1 1/8	146.6 5.77	67.1 2.64	71.6 2.82	18.8 0.74	112.0 4.41	139.2 5.48	20.2 44.4	
TAPK26K407S TAAPK26K407S	4 7/8 in.	22226	155.6 6.125	283.2 11.15	165.1 6.50	387.4 15.25	425.5 16.75	108.0 4.25	514.4 20.25	171.5 6.75	50.8 2.00	24 1 1/8	157.5 6.20	71.9 2.83	76.6 3.01	15.9 0.63	120.9 4.76	149.65 5.89	61.7 136	
TAPK26K408S TAAPK26K408S	4 1/2 in.																			
TAPK26K115S TAAPK26K115S	115 mm																			
TAPK28K415S TAAPK28K415S	4 15/16 in.	22228	169.9 6.69	322.3 12.69	180.1 7.09	444.5 17.50	485.9 19.13	93.7 3.69	558.8 22.00	157.2 6.19	50.8 2.00	24 1 1/8	156.2 6.15	77.5 3.05	85.2 3.35	22.1 0.87	131.1 5.16	161.2 6.34	28.0 61.5	
TAPK28K500S TAAPK28K500S	5 in.																			
TAPK32K507S TAAPK32K507S	5 7/8 in.	23132	179.4 7.06	338.1 13.31	210.0 8.27	500.1 19.69	541.3 21.31	106.4 4.19	628.7 24.75	171.5 6.75	54.1 2.13	24 1 1/8	176.3 6.94	-	90.5 3.56	11.9 0.47	-	185.0 7.28	39.5 87.0	
TAPK34K515S TAAPK34K515S	5 15/16 in.	23134	200.0 7.88	371.6 14.63	220.0 8.66	563.6 22.19	604.8 23.81	112.8 4.44	711.2 28.00	190.5 7.50	60.5 2.38	30 1 1/4	190.0 7.48	-	94.7 3.73	9.4 0.37	-	187.5 7.38	43.5 95.7	
TAPK34K600S TAAPK34K600S	6 in.																			
TAPK36K607S TAAPK36K607S	6 7/8 in.	23136	200.0 7.88	381.7 15.03	230.0 9.06	563.6 22.19	604.8 23.81	112.8 4.44	711.2 28.00	190.5 7.50	60.5 2.38	30 1 1/4	194.3 7.65	-	99.0 3.90	15.0 0.59	-	196.7 7.74	50.9 112.0	

TA4SD AND TAA4SD SPECIAL DUTY-STYLE FOUR-BOLT PILLOW BLOCK

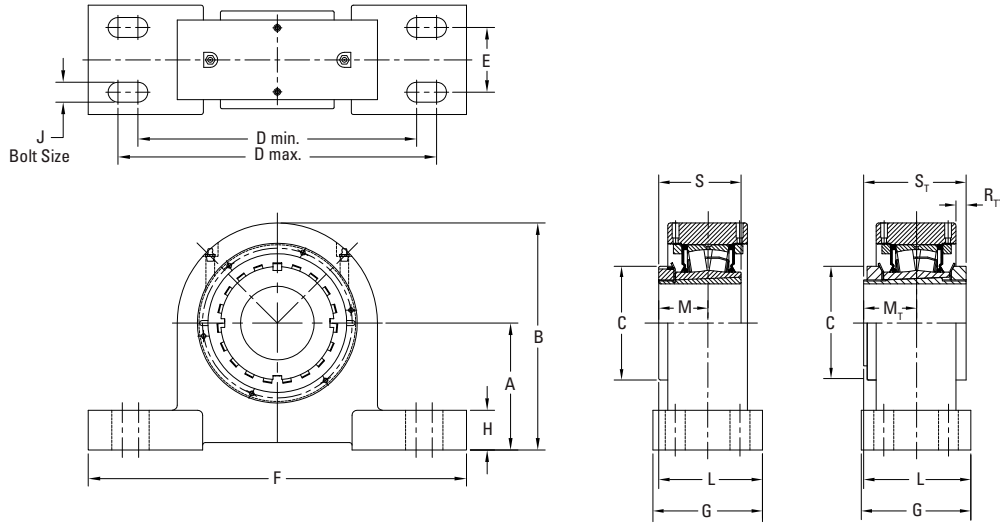

Bearing Part No.	Shaft Dia.	Bearing No.	A	B	C	D min.	D max.	E	F	G	H	J	L	M	M _T	R _{TT}	S	S _T	Wt.
	mm in.		mm in.	mm in.	mm in.	mm in.	mm in.	mm in.	mm in.	mm in.	mm in.	mm in.	mm in.	mm in.	mm in.	mm in.	mm in.	mm in.	kg lbs.
TA4SD15K207S TAA4SD15K207S	2 7/16 in.	22215	101.6 4.00	182.1 7.17	98.04 3.86	251.0 9.88	295.4 11.63	63.5 2.5	336.6 13.25	103.4 4.07	31.8 1.25	M16 5/8	98.7 3.89	43.9 1.73	47.0 1.85	8.60 0.34	72.9 2.87	87.9 3.46	18 39
TA4SD15K208S TAA4SD15K208S	2 1/2 in.																		
TA4SD15K065S TAA4SD15K065S	65 mm	22217	120.7 4.75	211.3 8.32	110.0 4.33	276.4 10.88	320.8 12.63	69.9 2.75	362.0 14.25	109.8 4.32	31.8 1.25	M16 5/8	108.5 4.27	49.8 1.96	53.6 2.11	11.9 0.47	82.0 3.23	99.6 3.92	24 52
TA4SD17K215S TAA4SD17K215S	2 15/16 in.																		
TA4SD17K300S TAA4SD17K300S	3 in.	22220	139.7 5.50	254.0 10	130.0 5.12	330.2 13.00	368.3 14.50	82.56 3.25	425.5 16.75	126.5 4.98	39.6 1.56	M20 3/4	119.4 4.70	56.1 2.21	56.1 2.21	15.5 0.61	97.0 3.82	116.8 4.60	39 87
TA4SD17K075S TAA4SD17K075S	75 mm																		
TA4SD20K307S TAA4SD20K307S	3 7/16 in.	22222	161.9 6.38	285.8 11.25	145.0 5.71	381.0 15.00	406.4 16.00	82.56 3.25	482.6 19.00	133.6 5.26	44.5 1.75	M24 7/8	129.3 5.09	63.0 2.48	62.5 2.46	16.6 0.66	105.0 4.13	126.0 4.96	52 115
TA4SD20K308S TAA4SD20K308S	3 1/2 in.																		
TA4SD20K090S TAA4SD20K090S	90 mm	22226	184.2 7.25	317.5 12.50	165.0 6.50	393.7 15.50	444.5 17.50	88.9 3.5	508.0 20.00	140.0 5.51	50.8 2.00	M24 7/8	143.8 5.66	71.9 2.83	73.8 2.91	20.1 0.79	121.0 4.76	143.8 5.66	67 148
TA4SD22K315S TAA4SD22K315S	3 15/16 in.																		
TA4SD22K400S TAA4SD22K400S	4 in.	22228	190.5 7.50	342.9 13.50	180.0 7.09	450.9 17.75	501.7 19.75	95.3 3.75	584.2 23.00	152.7 6.01	50.8 2.00	M24 1	155.7 6.13	77.5 3.05	79.3 3.12	10.5 0.41	131.0 5.16	154.9 6.10	89 196
TA4SD22K100S TAA4SD22K100S	100 mm																		
TA4SD26K407S TAA4SD26K407S	4 7/16 in.	23132 ⁽¹⁾	228.6 9.00	400.1 15.75	210.0 8.27	543.1 21.38	600.2 23.63	127.0 5.00	679.5 26.75	190.8 7.51	63.5 2.50	M24 1 1/8	185.8 7.32	-	90.5 3.56	19.1 0.75	-	185.0 7.28	150 331
TA4SD26K408S TAA4SD26K408S	4 1/2 in.																		
TA4SD26K115S TAA4SD26K115S	115 mm	22228	190.5 7.50	342.9 13.50	180.0 7.09	450.9 17.75	501.7 19.75	95.3 3.75	584.2 23.00	152.7 6.01	50.8 2.00	M24 1	155.7 6.13	77.5 3.05	79.3 3.12	10.5 0.41	131.0 5.16	154.9 6.10	89 196
TA4SD28K415S TAA4SD28K415S	4 15/16 in.																		
TA4SD28K500S TAA4SD28K500S	5 in.	23132 ⁽¹⁾	228.6 9.00	400.1 15.75	210.0 8.27	543.1 21.38	600.2 23.63	127.0 5.00	679.5 26.75	190.8 7.51	63.5 2.50	M24 1 1/8	185.8 7.32	-	90.5 3.56	19.1 0.75	-	185.0 7.28	150 331
TA4SD28K125S TAA4SD28K125S	125 mm																		
TA4SD32K140S TAA4SD32K140S	140 mm	23132 ⁽¹⁾	228.6 9.00	400.1 15.75	210.0 8.27	543.1 21.38	600.2 23.63	127.0 5.00	679.5 26.75	190.8 7.51	63.5 2.50	M24 1 1/8	185.8 7.32	-	90.5 3.56	19.1 0.75	-	185.0 7.28	150 331
TA4SD32K506S TAA4SD32K506S	5 3/8 in.																		
TA4SD32K507S TAA4SD32K507S	5 7/16 in.	23132 ⁽¹⁾	228.6 9.00	400.1 15.75	210.0 8.27	543.1 21.38	600.2 23.63	127.0 5.00	679.5 26.75	190.8 7.51	63.5 2.50	M24 1 1/8	185.8 7.32	-	90.5 3.56	19.1 0.75	-	185.0 7.28	150 331
TA4SD32K508S TAA4SD32K508S	5 1/2 in.																		

⁽¹⁾Insert size 23132K and above come standard with double nut tapered adapter.

TA4SD AND TAA4SD SPECIAL DUTY-STYLE FOUR-BOLT PILLOW BLOCK

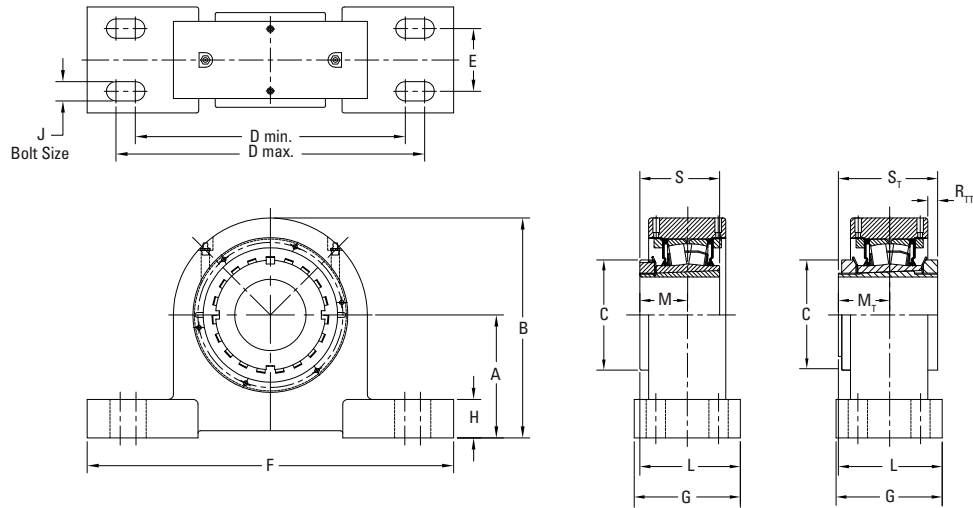

Bearing Part No.	Shaft Dia.	Bearing No.	A	B	C	D min.	D max.	E	F	G	H	J	L	M	M _T	R _{TT}	S	S _T	Wt.	
	mm in.		mm in.	mm in.	mm in.	mm in.	mm in.	mm in.	mm in.	mm in.	mm in.	mm in.	mm in.	mm in.	mm in.	mm in.	mm in.	mm in.	mm in.	kg lbs.
TAA4SD34K150S	150 mm	23134 ⁽¹⁾	228.6 9.00	400.1 15.75	220.0 8.66	543.1 21.38	600.2 23.63	127.0 5.00	679.5 26.75	190.8 7.51	63.5 2.50	M24 1 ¹ / ₈	190.1 7.49	-	94.7 3.73	15.0 0.59	-	187.5 7.38	151 332	
TAA4SD34K513S	5 ³ / ₁₆ in.																			
TAA4SD34K514S	5 ⁷ / ₁₆ in.																			
TAA4SD34K515S	5 ¹ / ₂ in.																			
TAA4SD34K600S	6 in.	23136 ⁽¹⁾	285.8 11.25	501.7 19.75	230.0 9.06	698.5 27.50	774.7 30.50	139.70 5.50	873.3 34.38	223.5 8.80	69.9 2.75	M36 1 ¹ / ₂	210.8 8.30	-	99.0 3.90	15.8 0.62	-	196.7 7.74	270 596	
TA4SD36K160S	160 mm																			
TAA4SD36K160S	6 ³ / ₁₆ in.																			
TA4SD36K605S	6 ⁵ / ₁₆ in.																			
TAA4SD36K605S	6 ⁵ / ₁₆ in.	23138 ⁽¹⁾	285.8 11.25	501.7 19.75	240 9.45	698.5 27.50	774.7 30.50	139.70 5.50	873.3 34.38	223.5 8.80	69.9 2.75	M36 1 ¹ / ₂	216.6 8.53	-	104.8 4.13	17.0 0.67	-	207.6 8.17	273 603	
TA4SD36K606S	6 ³ / ₁₆ in.																			
TAA4SD36K606S	6 ³ / ₁₆ in.																			
TA4SD36K607S	6 ⁷ / ₁₆ in.																			
TAA4SD36K607S	6 ⁷ / ₁₆ in.	23144 ⁽¹⁾	317.5 12.50	558.8 22.00	280.0 11.02	774.7 30.50	863.6 34.00	152.4 6.00	984.3 38.75	260.6 10.26	85.1 3.35	M42 1 ³ / ₄	249.2 9.81	-	119.0 4.68	21.8 0.86	-	234.7 9.24	380 838	
TA4SD36K608S	6 ¹ / ₂ in.																			
TAA4SD36K608S	6 ¹ / ₂ in.																			
TA4SD38K170S	170 mm																			
TAA4SD38K170S	6 ¹ / ₁₆ in.	23144 ⁽¹⁾	317.5 12.50	558.8 22.00	280.0 11.02	774.7 30.50	863.6 34.00	152.4 6.00	984.3 38.75	260.6 10.26	85.1 3.35	M42 1 ³ / ₄	249.2 9.81	-	119.0 4.68	21.8 0.86	-	234.7 9.24	380 838	
TA4SD38K613S	6 ¹ / ₁₆ in.																			
TAA4SD38K613S	6 ¹ / ₁₆ in.																			
TA4SD38K614S	6 ³ / ₁₆ in.																			
TAA4SD38K614S	6 ³ / ₁₆ in.	23144 ⁽¹⁾	317.5 12.50	558.8 22.00	280.0 11.02	774.7 30.50	863.6 34.00	152.4 6.00	984.3 38.75	260.6 10.26	85.1 3.35	M42 1 ³ / ₄	249.2 9.81	-	119.0 4.68	21.8 0.86	-	234.7 9.24	380 838	
TA4SD38K615S	6 ¹ / ₁₆ in.																			
TAA4SD38K615S	6 ¹ / ₁₆ in.																			
TA4SD38K700S	7 in.																			
TAA4SD38K700S	7 in.	23144 ⁽¹⁾	317.5 12.50	558.8 22.00	280.0 11.02	774.7 30.50	863.6 34.00	152.4 6.00	984.3 38.75	260.6 10.26	85.1 3.35	M42 1 ³ / ₄	249.2 9.81	-	119.0 4.68	21.8 0.86	-	234.7 9.24	380 838	
TA4SD44K715S	200 mm																			
TAA4SD44K715S	7 ¹ / ₁₆ in.																			
TA4SD44K715S	7 ¹ / ₁₆ in.																			
TAA4SD44K715S	7 ¹ / ₁₆ in.	23144 ⁽¹⁾	317.5 12.50	558.8 22.00	280.0 11.02	774.7 30.50	863.6 34.00	152.4 6.00	984.3 38.75	260.6 10.26	85.1 3.35	M42 1 ³ / ₄	249.2 9.81	-	119.0 4.68	21.8 0.86	-	234.7 9.24	380 838	
TA4SD44K715S	7 ¹ / ₁₆ in.																			
TAA4SD44K715S	7 ¹ / ₁₆ in.																			
TA4SD44K800S	8 in.																			
TAA4SD44K800S	8 in.																			

⁽¹⁾Insert size 23132K and above come standard with double nut tapered adapter

TA4DI AND TAA4DI DI-STYLE FOUR-BOLT PILLOW BLOCK

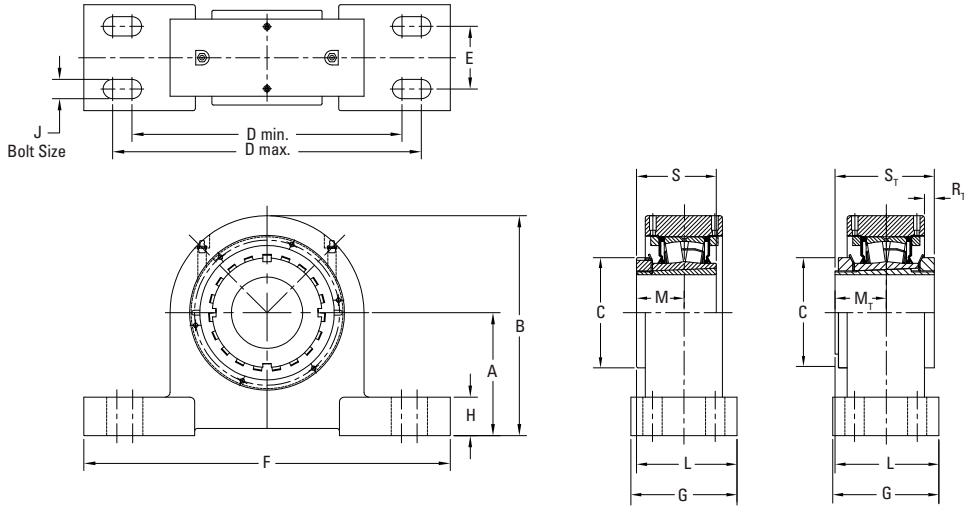

Bearing Part No.	Shaft Dia.	Bearing No.	A	B	C	D min.	D max.	E	F	G	H	J	L	M	M _T	R _{TT}	S	S _T	Wt.	
	mm in.		mm in.	mm in.	mm in.	mm in.	mm in.	mm in.	mm in.	mm in.	mm in.	mm in.	mm in.	mm in.	mm in.	mm in.	mm in.	mm in.	kg lbs.	
TA4DI15K207S TAA4DI15K207S	2 7/8 in.	22215	82.6 3.25	162.1 6.38	98.0 3.86	235.0 9.20	260.4 10.25	44.5 1.75	304.8 12.00	76.2 3.00	31.8 1.25	M12 ½	78.9 3.11	43.9 1.73	47.0 1.85	8.60 0.34	72.9 2.87	92.3 3.46	14 30	
TA4DI15K208S TAA4DI15K208S	2 ½ in.																			
TA4DI15K065S TAA4DI15K065S	65 mm	22217	95.3 3.75	185.7 7.32	110.0 4.33	250.8 9.88	292.1 11.50	47.6 1.88	341.4 13.44	88.9 3.50	31.8 1.25	M16 5/8	94.2 3.71	49.8 1.96	53.6 2.11	11.9 0.47	82.0 3.23	104.3 3.92	19 42	
TA4DI17K215S TAA4DI17K215S	2 15/16 in.																			
TA4DI17K300S TAA4DI17K300S	3 in.	22220	114.3 4.50	220.4 8.68	130.0 5.12	325.4 12.81	350.8 13.81	50.8 2.00	406.4 16.00	95.3 3.75	39.6 1.56	M20 ¾	106.0 4.18	58.4 2.30	56.1 2.21	15.5 0.61	97.0 3.82	108.8 4.10	29 65	
TA4DI17K075S TAA4DI17K075S	75 mm																			
TA4DI20K307S TAA4DI20K307S	3 7/8 in.	22222	127.0 5.00	250.8 9.88	145.0 5.71	333.4 13.13	374.7 14.75	50.8 2.00	443.0 17.44	101.6 4.00	44.5 1.75	M20 ¾	113.8 4.48	63.0 2.48	62.5 2.46	16.6 0.66	105.0 4.13	121.8 4.60	40 88	
TA4DI20K308S TAA4DI20K308S	3 ½ in.																			
TA4DI20K090S TAA4DI20K090S	90 mm	22226	146.1 5.75	279.4 11.00	165.0 6.50	365.1 14.38	412.8 16.25	57.2 2.25	482.6 19.00	114.3 4.50	50.8 2.00	M20 ¾	122.7 4.83	71.9 2.83	73.9 2.91	20.1 0.79	121.0 4.76	121.0 4.76	54 118	
TA4DI22K315S TAA4DI22K315S	3 15/16 in.																			
TA4DI22K400S TAA4DI22K400S	4 in.	22226	146.1 5.75	279.4 11.00	165.0 6.50	365.1 14.38	412.8 16.25	57.2 2.25	482.6 19.00	114.3 4.50	50.8 2.00	M20 ¾	122.7 4.83	71.9 2.83	73.9 2.91	20.1 0.79	121.0 4.76	121.0 4.76	54 118	
TA4DI22K100S TAA4DI22K100S	100 mm																			
TA4DI26K407S TAA4DI26K407S	4 7/8 in.	22226	146.1 5.75	279.4 11.00	165.0 6.50	365.1 14.38	412.8 16.25	57.2 2.25	482.6 19.00	114.3 4.50	50.8 2.00	M20 ¾	122.7 4.83	71.9 2.83	73.9 2.91	20.1 0.79	121.0 4.76	121.0 4.76	54 118	
TA4DI26K408S TAA4DI26K408S	4 ½ in.																			
TA4DI26K115S TAA4DI26K115S	115 mm																			

⁽¹⁾Insert size 23132K and above come standard with double nut tapered adapter

TA4DI AND TAA4DI DI-STYLE FOUR-BOLT PILLOW BLOCK

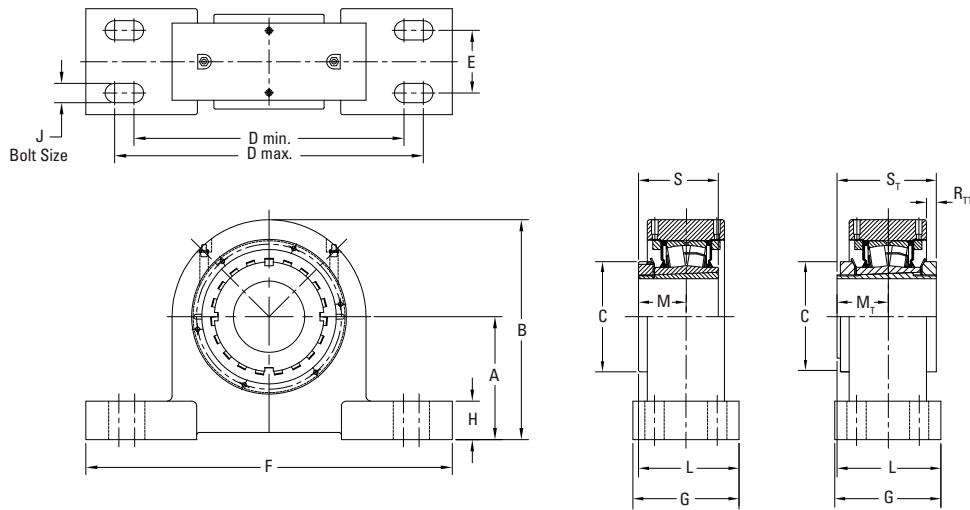

Bearing Part No.	Shaft Dia.	Bearing No.	A	B	C	D min.	D max.	E	F	G	H	J	L	M	M _T	R _{TT}	S	S _T	Wt.	
			mm in.	mm in.	mm in.	mm in.	mm in.	mm in.	mm in.	mm in.	mm in.	mm in.	mm in.	mm in.	mm in.	mm in.	mm in.	mm in.	mm in.	mm in.
TA4DI28K415S TAA4DI28K415S	4 1/8 in.	22228	158.8	311.2	180.0	393.7	458.7	63.5	520.7	120.4	50.8	M24	134.6	77.5	79.3	10.5	131.0	131.0	72	
TA4DI28K500S TAA4DI28K500S	5 in.		6.25	12.25	7.09	15.50	18.06	2.50	20.50	4.74	2.00	M24 7/8	5.30	3.05	3.12	0.41	5.16	5.16	159	
TA4DI28K125S TAA4DI28K125S	125 mm																			
TAA4DI32K140S	140 mm																			
TAA4DI32K506S	5 3/8 in.	23132 ⁽¹⁾	181.1	352.6	210.0	482.6	524.0	76.2	601.7	165.1	63.5	M24	168.7	-	90.5	19.1	-	185.0	119	
TAA4DI32K507S	5 7/8 in.		7.13	13.88	8.27	19.00	20.63	3.00	23.69	6.50	2.50	M24 1	6.64		3.56	0.75		7.28	263	
TAA4DI32K508S	5 1/2 in.																			
TAA4DI34K150S	150 mm	23134 ⁽¹⁾	181.1	352.6	220.0	482.6	524.0	76.2	601.7	167.6	63.5	M24	169.6	-	94.7	15.0	-	186.7	120	
TAA4DI34K513S	5 13/16 in.		7.13	13.88	8.66	19.00	20.63	3.00	23.69	6.60	2.50	M24 1	6.68		3.73	0.59		7.35	264	
TAA4DI34K514S	5 7/8 in.																			
TAA4DI34K515S	5 15/16 in.																			
TAA4DI34K600S	6 in.																			

⁽¹⁾Insert size 23132K and above come standard with double nut tapered adapter

TAPH AND TAAPH SAF-STYLE FOUR-BOLT PILLOW BLOCKS

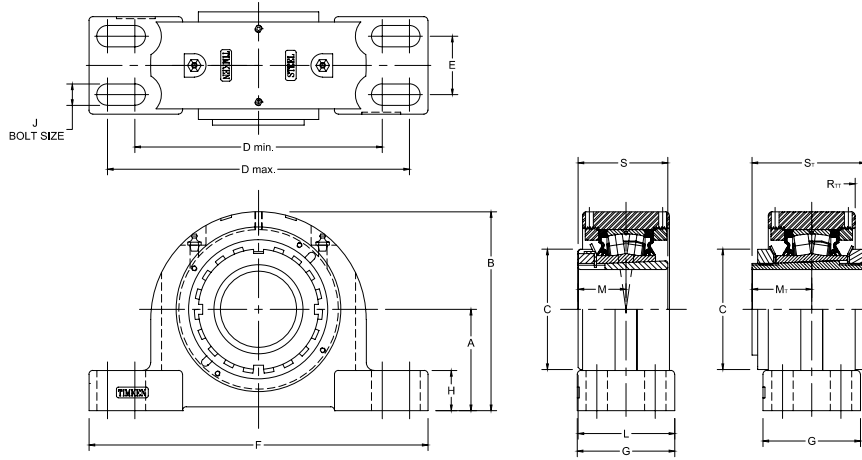

Bearing Part No.	Shaft Dia.	Bearing No.	A	B	C	D min.	D max.	E	F	G	H	J	L	M	M _T	R _T	S	S _T	Wt.
	mm in.		mm in.	mm in.	mm in.	mm in.	mm in.	mm in.	mm in.	mm in.	mm in.	mm in.	mm in.	mm in.	mm in.	mm in.	mm in.	mm in.	mm lbs.
TAPH11K115S TAAPH11K115S	1 15/16 in.	22211	69.9 2.75	134.9 5.31	74.9 2.95	182.4 7.18	217.4 8.56	39.9 1.57	251.0 9.88	68.6 2.70	31.8 1.25	16 5/8	69.9 2.75	35.6 1.40	39.1 1.54	7.1 0.28	58.9 2.32	76.33 3.01	8.6 19
TAPH11K200S TAAPH11K200S	2 in.																		
TAPH11K050S TAAPH11K050S	50 mm																		
TAPH13K203S TAAPH13K203S	2 3/8 in.	22213	76.2 3.00	151.1 5.95	85.1 3.35	182.4 7.18	217.4 8.56	50.8 2.00	261.9 10.31	82.6 3.25	31.2 1.23	12 1/2	81.0 3.19	39.6 1.56	43.7 1.72	5.1 0.20	65.0 2.56	82.83 3.26	11.3 25
TAPH13K204S TAAPH13K204S	2 1/4 in.																		
TAPH13K060S TAAPH13K060S	60 mm																		
TAPH15K207S TAAPH15K207S	2 7/8 in.	22215	82.6 3.25	162.1 6.38	98.0 3.86	201.7 7.94	246.1 9.69	47.8 1.88	276.4 10.88	79.5 3.13	32.8 1.29	12 1/2	83.6 3.29	43.9 1.73	48.7 1.92	8.3 0.33	72.9 2.87	92.33 3.64	13.2 29
TAPH15K208S TAAPH15K208S	2 1/2 in.																		
TAPH15K065S TAAPH15K065S	65 mm																		
TAPH16K211S TAAPH16K211S	2 11/16 in.	22216	88.9 3.50	176.6 6.96	104.7 4.12	228.6 9.00	279.4 11.00	53.9 2.13	330.2 13.00	88.9 3.50	31.7 1.25	16 5/8	91.7 3.61	47.5 1.87	51.7 2.04	11.3 0.45	77.7 3.06	99.33 3.91	14.5 32
TAPH16K212S TAAPH16K212S	2 3/4 in.																		
TAPH16K070S TAAPH16K070S	70 mm																		
TAPH17K215S TAAPH17K215S	2 15/16 in.	22217	95.3 3.75	182.9 7.20	110.0 4.33	239.8 9.44	287.3 11.31	53.9 2.13	320.8 12.63	92.2 3.63	32.0 1.26	16 5/8	96.0 3.78	49.8 1.96	50.2 1.98	16.0 0.63	82.0 3.23	104.33 4.12	16.8 37
TAPH17K300S TAAPH17K300S	3 in.																		
TAPH17K075S TAAPH17K075S	75 mm																		
TAPH18K303S TAAPH18K303S	3 3/8 in.	22218	101.6 4.00	202.1 7.96	119.6 4.71	254.0 10.00	298.5 11.75	54.0 2.13	349.3 13.75	98.4 3.88	41.3 1.63	16 5/8	101.2 3.98	52.0 2.05	56.6 2.23	12.3 0.49	86.0 3.39	108.83 4.28	19.1 42
TAPH18K304S TAAPH18K304S	3 1/4 in.																		
TAPH18K080S TAAPH18K080S	80 mm																		

TAPH AND TAAPH SAF-STYLE FOUR-BOLT PILLOW BLOCKS

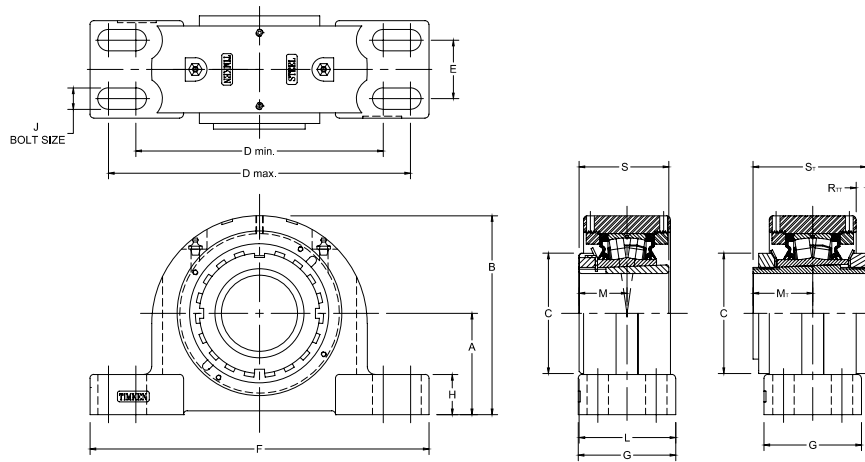

Bearing Part No.	Shaft Dia.	Bearing No.	A	B	C	D min.	D max.	E	F	G	H	J	L	M	M _T	R _T	S	S _T	Wt.	
	mm in.		mm in.	mm in.	mm in.	mm in.	mm in.	mm in.	mm in.	mm in.	mm in.	mm in.	mm in.	mm in.	mm in.	mm in.	mm in.	mm in.	mm in.	mm lbs.
TAPH20K307S TAAPH20K307S	3 ⁷ / ₁₆ in.	22220	114.3 4.50	216.9 8.54	130.0 5.12	276.4 10.88	339.9 13.38	60.5 2.38	381 15.00	109.5 4.31	41.9 1.65	20 3/4	113.3 4.46	58.4 2.30	63.6 2.51	10.6 0.42	97.0 3.82	121.83 4.80	31.8 70	
TAPH20K308S TAAPH20K308S	3 1/2 in.																			
TAPH20K090S TAAPH20K090S	90 mm																			
TAPH22K315S TAAPH22K315S	3 15/16 in.	22222	125.5 4.94	238.3 9.38	145.0 5.71	301.8 11.88	368.3 14.50	69.9 2.75	406.4 16.00	120.7 4.75	45.0 1.77	20 3/4	123.4 4.86	63.0 2.48	65.8 2.59	14.1 0.56	104.9 4.13	130.7 5.15	39.5 87	
TAPH22K400S TAAPH22K400S	4 in.																			
TAPH22K100S TAAPH22K100S	100 mm																			
TAPH24K403S TAAPH24K403S	4 3/16 in.	22224	133.4 5.25	256.7 10.11	154.5 6.08	330.2 13.00	368.3 14.50	69.9 2.75	419.1 16.50	120.7 4.75	50.8 2.00	20 3/4	127.3 5.01	67.0 2.64	71.6 2.82	18.7 0.73	112.0 4.41	139.15 5.48	49.9 110	
TAPH24K404S TAAPH24K404S	4 1/4 in.																			
TAPH24K110S TAAPH24K110S	110 mm																			
TAPH26K407S TAAPH26K407S	4 7/16 in.	22226	152.4 6.00	284.0 11.18	165.1 6.50	362.0 14.25	406.4 16.00	82.6 3.25	450.85 17.75	128.0 5.04	51.8 2.04	22 7/8	135.9 5.35	71.9 2.83	76.6 3.01	20.4 0.80	120.9 4.76	149.65 5.89	61.7 136	
TAPH26K408S TAAPH26K408S	4 1/2 in.																			
TAPH26K115S TAAPH26K115S	115 mm																			
TAPH28K415S TAAPH28K415S	4 15/16 in.	22228	152.4 6.00	290.8 11.45	180.1 7.09	406.4 16.00	435.1 17.13	85.9 3.38	500.4 19.70	128.0 5.04	51.8 2.04	24 1	141.5 5.57	77.5 3.05	85.2 3.35	18.3 0.72	131.1 5.16	161.15 6.34	61.8 136	
TAPH28K500S TAAPH28K500S	5 in.																			
TAPH28K125S TAAPH28K125S	125 mm																			

TAAPH SAF 500-STYLE FOUR-BOLT PILLOW BLOCKS

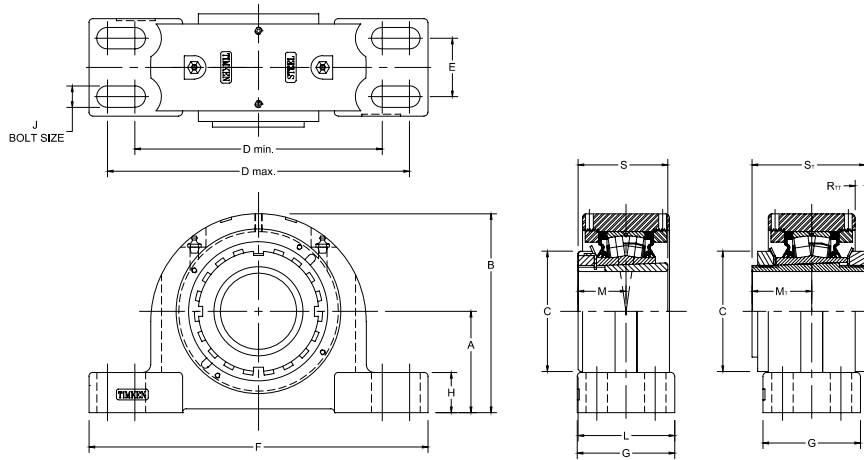

Bearing Part No. ⁽¹⁾	Shaft Dia.	Bearing No.	A	B	C	D min.	D max.	E	F	G	H	J	L	M _T	R _{TT}	S _T	Wt.
	mm in.		mm in.	mm in.	mm in.	mm in.	mm in.	mm in.	mm in.	mm in.	mm in.	mm in.	mm in.	mm in.	mm in.	mm in.	kg lbs.
TAAPH30K503S0	5 3/16 in.	23130	160.3	320.6	200.0	431.8	463.6	95.2	539.8	171.5	66.2	M24	170	84	8	175	95.2
TAAPH30K504S0	5 1/4 in.		6.31	12.62	7.89	17.00	18.25	3.75	21.25	6.75	2.61	1	6.69	3.32	0.32	6.89	210
TAAPH30K135S0	135 mm																
TAAPH32K140S0	140 mm	23132	169.9	330.2	210.0	441.3	489.0	95.2	558.8	171.5	76.2	M24	176	91	12	185	122.4
TAAPH32K506S0	5 3/8 in.		6.69	13.00	8.27	17.38	19.25	3.75	22.00	6.75	3.00	1	6.94	3.56	0.47	7.28	270
TAAPH32K507S0	5 7/16 in.																
TAAPH32K508S0	5 1/2 in.	23134	179.4	339.8	220.0	493.6	549.4	108.0	628.7	171.5	85.9	M24	180	95	13	188	132.9
TAAPH34K150S0	150 mm		7.06	13.38	8.66	19.38	21.63	4.25	24.75	6.75	3.38	1	7.10	3.73	0.52	7.38	293
TAAPH34K513S0	5 13/16 in.																
TAAPH34K514S0	5 7/8 in.	23136	190.5	391.2	230.0	531.8	600.2	117.5	679.5	190.5	76.2	M24	196	99	14	197	159.2
TAAPH34K515S0	5 15/16 in.		7.50	15.40	9.06	20.88	23.63	4.63	26.75	7.5	3.00	1	7.72	3.90	0.57	7.74	351
TAAPH34K600S0	6 in.																
TAAPH36K160S0	160 mm	23138	200.0	400.1	240.0	550.9	619.3	114.3	711.2	190.5	85.9	M30	206.7	105	13.2	208	185.9
TAAPH36K605S0	6 3/16 in.		7.88	15.75	9.45	21.63	24.38	4.50	28.00	7.50	3.38	1 1/4	8.14	4.13	0.52	8.17	410
TAAPH36K606S0	6 3/8 in.																
TAAPH36K607S0	6 7/16 in.	23140	209.6	429.3	250.0	573.1	635.0	127.0	749.3	210.0	80.0	M30	215	110	16	218	207.7
TAAPH36K608S0	6 1/2 in.		8.25	16.16	9.84	22.50	25.00	5.00	29.50	8.27	3.15	1 1/4	8.46	4.32	0.65	8.57	458
TAAPH38K170S0	170 mm																
TAAPH38K613S0	6 13/16 in.	23144	241.3	455.3	280.0	630.4	708.2	133.4	831.9	225.0	85.1	M36	231	119	21	235	284.4
TAAPH38K614S0	6 7/8 in.		9.50	17.93	11.02	24.75	27.88	5.25	32.75	8.86	3.35	1 1/2	9.11	4.68	0.81	9.24	627
TAAPH38K615S0	6 15/16 in.																
TAAPH38K700S0	7 in.	23140	209.6	429.3	250.0	573.1	635.0	127.0	749.3	210.0	80.0	M30	215	110	16	218	207.7
TAAPH40K180S0	180 mm		8.25	16.16	9.84	22.50	25.00	5.00	29.50	8.27	3.15	1 1/4	8.46	4.32	0.65	8.57	458
TAAPH40K702S0	7 1/8 in.																
TAAPH40K703S0	7 3/16 in.	23144	241.3	455.3	280.0	630.4	708.2	133.4	831.9	225.0	85.1	M36	231	119	21	235	284.4
TAAPH40K704S0	7 1/4 in.		9.50	17.93	11.02	24.75	27.88	5.25	32.75	8.86	3.35	1 1/2	9.11	4.68	0.81	9.24	627
TAAPH44K200S0	200 mm																
TAAPH44K713S0	7 13/16 in.	23144	241.3	455.3	280.0	630.4	708.2	133.4	831.9	225.0	85.1	M36	231	119	21	235	284.4
TAAPH44K714S0	7 7/8 in.		9.50	17.93	11.02	24.75	27.88	5.25	32.75	8.86	3.35	1 1/2	9.11	4.68	0.81	9.24	627
TAAPH44K715S0	7 15/16 in.																
TAAPH44K800S0	8 in.																

⁽¹⁾Insert size 23132K and above come standard with double nut tapered adapter

TAAPHD SDAF 500-STYLE FOUR-BOLT PILLOW BLOCKS

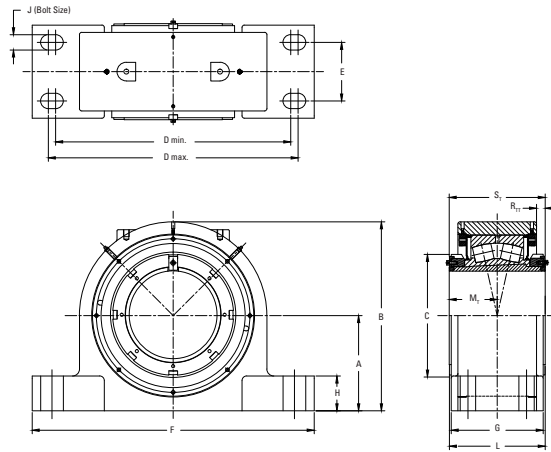

Bearing Part No. ⁽¹⁾	Shaft Dia.	Bearing No.	A	B	C	D min.	D max.	E	F	G	H	J	L	M _T	R _T	S _T	Wt.
			mm in.	mm in.	mm in.	mm in.	mm in.	mm in.	mm in.	mm in.	mm in.	mm in.	mm in.	mm in.	mm in.	mm in.	mm in.
TAAPH34DK150S0	150 mm	23134	179.3 7.06	370.0 14.60	199.9 7.87	492.3 19.38	549.4 21.63	139.7 5.50	628.7 24.75	215.9 8.50	65.0 2.56	M30 1 ¼	203 7.98	95 3.73	13 0.52	188 7.38	132.9 293
TAAPH34DK513S0	5 13/16 in.																
TAAPH34DK514S0	5 7/8 in.																
TAAPH34DK515S0	5 15/16 in.																
TAAPH34DK600S0	6 in.																
TAAPH36DK160S0	160 mm	23136	190.5 7.50	391.2 15.40	210.1 8.27	530.4 20.88	600.2 23.63	149.4 5.88	679.5 26.75	219.5 8.64	69.9 2.75	M30 1 ¼	209 8.22	99 3.90	14 0.57	197 7.74	158.3 349
TAAPH36DK605S0	6 5/16 in.																
TAAPH36DK606S0	6 3/8 in.																
TAAPH36DK607S0	6 7/16 in.																
TAAPH36DK608S0	6 1/2 in.																
TAAPH38DK170S0	170 mm	23138	200.1 7.88	410.8 16.17	219.9 8.66	546.1 21.50	596.9 23.50	158.8 6.25	701.8 27.63	235.0 9.25	74.9 2.95	M30 1 3/8	199 7.83	104 4.08	13 0.52	208 8.17	186.8 412
TAAPH38DK613S0	6 13/16 in.																
TAAPH38DK614S0	6 7/8 in.																
TAAPH38DK615S0	6 15/16 in.																
TAAPH38DK700S0	7 in.																
TAAPH40DK180S0	180 mm	23140	209.5 8.25	429.2 16.90	240.0 9.45	584.2 23.00	635.0 25.00	171.5 6.75	730.3 28.75	247.7 9.75	80.0 3.15	M30 1 3/8	234 9.21	110 4.32	16 0.65	218 8.57	220.4 486
TAAPH40DK702S0	7 1/8 in.																
TAAPH40DK703S0	7 3/16 in.																
TAAPH40DK704S0	7 1/4 in.																
TAAPH44DK200S0	200 mm																
TAAPH44DK713S0	7 13/16 in.																
TAAPH44DK714S0	7 7/8 in.																
TAAPH44DK715S0	7 15/16 in.																
TAAPH44DK800S0	8 in.																

TAAPH6 SAF 600-STYLE FOUR-BOLT PILLOW BLOCKS

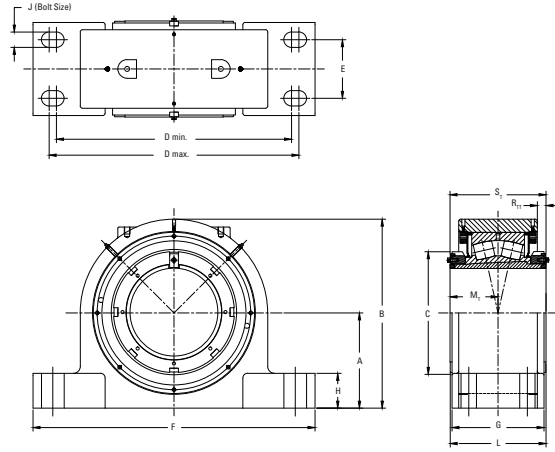

Bearing Part No. ⁽¹⁾	Shaft Dia.	Bearing No.	A	B	C	D min.	D max.	E	F	G	H	J	L	M _T	R _T	S _T	Wt.
	mm in.		mm in.	mm in.	mm in.	mm in.	mm in.	mm in.	mm in.	mm in.	mm in.	mm in.	mm in.	mm in.	mm in.	mm in.	kg lbs.
TAAPH634K150SO	150 mm	23134	209.6 8.25	400.4 15.76	220.0 8.66	571.5 22.50	635.0 25.00	127.0 5.00	749.3 29.50	203.2 8.00	65.0 2.56	M30 1 ¼	196 7.73	95 3.73	13 0.53	187.5 7.38	161.1 355
TAAPH634K513SO	5 13/16 in.																
TAAPH634K514SO	5 7/8 in.																
TAAPH634K515SO	5 15/16 in.																
TAAPH634K600SO	6 in.																
TAAPH636K160SO	160 mm	23136	225.4 8.88	426.7 16.80	230.0 9.06	609.6 24.00	676.3 26.63	133.4 5.25	793.8 31.25	250.8 9.88	69.9 2.75	M30 1 ¼	224 8.84	99 3.90	14 0.57	197 7.74	193.6 427
TAAPH636K605SO	6 5/16 in.																
TAAPH636K606SO	6 3/8 in.																
TAAPH636K607SO	6 7/16 in.																
TAAPH636K608SO	6 1/2 in.																
TAAPH638K170SO	170 mm	23138	241.3 9.50	452.1 17.80	240.0 9.45	268.7 24.75	708.0 27.88	133.4 5.25	831.9 32.75	209.6 8.25	74.9 2.95	M36 1 ½	210 8.26	105 4.13	15 0.60	208 8.17	229.1 505
TAAPH638K613SO	6 13/16 in.																
TAAPH638K614SO	6 7/8 in.																
TAAPH638K615SO	6 15/16 in.																
TAAPH638K700SO	7 in.																
TAAPH640K180SO	180 mm	23140	250.8 9.88	472.4 18.6	250.0 9.84	666.8 26.25	749.3 29.50	139.7 5.50	870.0 34.3	215.9 8.50	80.0 3.15	M36 1 ½	217.9 8.58	110 4.32	16 0.65	218 8.57	272.4 601
TAAPH640K702SO	7 1/8 in.																
TAAPH640K703SO	7 3/16 in.																
TAAPH640K704SO	7 1/4 in.																

TAAPH6D SDAF 600-STYLE FOUR-BOLT PILLOW BLOCKS

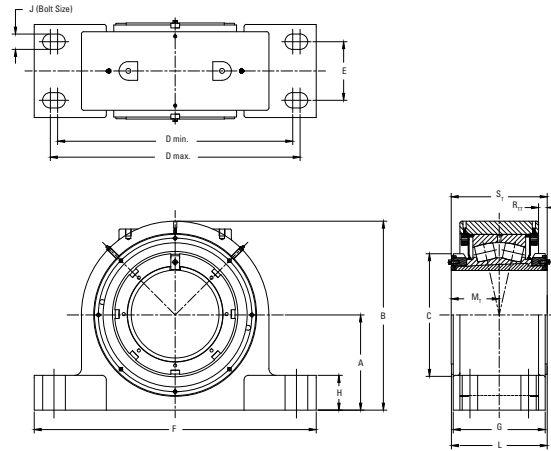

Bearing Part No. ⁽¹⁾	Shaft Dia.	Bearing No.	A	B	C	D min.	D max.	E	F	G	H	J	L	M _T	R _T	S _T	Wt.
	mm in.		mm in.	mm in.	mm in.	mm in.	mm in.	mm in.	mm in.	mm in.	mm in.	mm in.	mm in.	mm in.	mm in.	mm in.	kg lbs.
TAAPH634DK150SO	150 mm	23134	209.6 8.25	400.4 15.76	220.0 8.66	584.2 23.00	635.0 25.00	171.5 6.75	730.3 28.75	247.7 9.75	65.0 2.56	M30 1 3/8	219 8.60	95 3.73	13 0.53	187.5 7.38	158.4 349
TAAPH634DK513SO	5 13/16 in.																
TAAPH634DK514SO	5 7/8 in.																
TAAPH634DK515SO	5 15/16 in.																
TAAPH634DK600SO	6 in.																
TAAPH636DK160SO	160 mm	23136	225.4 8.88	426.7 16.80	230.0 9.06	612.8 24.13	669.9 26.38	174.6 6.88	774.7 30.50	250.8 9.88	69.9 2.75	M36 1 1/2	224 8.84	99 3.90	14 0.57	197 7.74	189.6 418
TAAPH636DK605SO	6 5/16 in.																
TAAPH636DK606SO	6 3/8 in.																
TAAPH636DK607SO	6 7/16 in.																
TAAPH636DK608SO	6 1/2 in.																
TAAPH638DK170SO	170 mm	23138	241.3 9.50	452.1 17.80	240.0 9.45	650.9 25.63	708.0 27.88	184.2 7.25	812.8 32.00	260.4 10.25	74.9 2.95	M36 1 1/2	235 9.26	105 4.13	15 0.60	208 8.17	226.4 500
TAAPH638DK613SO	6 13/16 in.																
TAAPH638DK614SO	6 7/8 in.																
TAAPH638DK615SO	6 15/16 in.																
TAAPH638DK700SO	7 in.																
TAAPH640DK180SO	180 mm	23140	250.8 9.88	472.4 18.6	250.0 9.84	676.3 26.63	743.0 29.25	193.7 7.63	850.9 33.5	269.9 10.63	80.0 3.15	M36 1 3/8	244.9 9.64	110 4.32	16 0.65	218 8.57	268.3 592
TAAPH640DK702SO	7 1/8 in.																
TAAPH640DK703SO	7 3/8 in.																
TAAPH640DK704SO	7 1/4 in.																

TAAPH0 SAF 230-STYLE FOUR-BOLT PILLOW BLOCKS

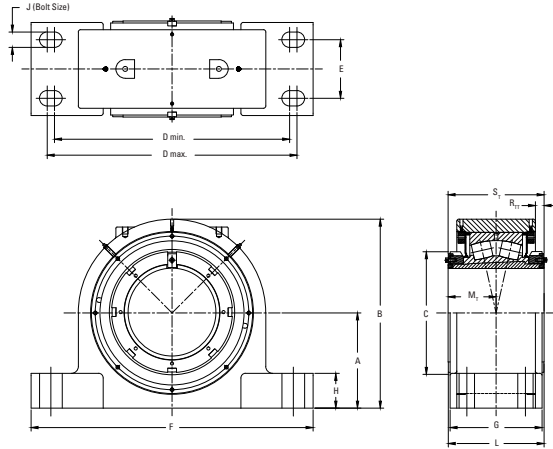

Bearing Part No.	Shaft Dia.	Bearing No.	A	B	C	D min.	D max.	E	F	G	H	J	L	M _T	R _T	S _T	Wt.
	mm in.		mm in.	mm in.	mm in.	mm in.	mm in.	mm in.	mm in.	mm in.	mm in.	mm in.	mm in.	mm in.	mm in.	mm in.	kg lbs.
TAAPH034K150S0	150 mm	23134	152.4 6.00	330.2 13.00	220 8.66	406.4 16.00	435.1 17.13	85.7 3.38	511.3 20.13	171.5 6.75	65.0 2.56	M24 1	184.8 7.28	99 3.90	9.10 0.36	188 7.38	106 234
TAAPH034K513S0	5 15/16 in.																
TAAPH034K514S0	5 7/8 in.																
TAAPH034K515S0	5 9/16 in.																
TAAPH034K600S0	6 in.																
TAAPH036K160S0	160 mm	23136	169.9 6.69	342.9 13.5	230 9.06	441.4 17.38	488.9 19.25	95.3 3.75	558.8 22.00	180.1 7.09	59.9 2.36	M24 1	189.1 7.45	99 3.90	14.0 0.57	197 7.74	131 289
TAAPH036K605S0	6 3/8 in.																
TAAPH036K606S0	6 3/8 in.																
TAAPH036K607S0	6 7/8 in.																
TAAPH036K608S0	6 1/2 in.																
TAAPH038K170S0	170 mm	23138	169.9 6.69	355.6 14.00	240 9.45	441.5 17.38	488.9 19.25	95.2 3.75	558.8 22.00	196.2 7.72	54.9 2.16	M24 1	203.0 7.99	105 4.13	15.3 0.60	208 8.17	145 319
TAAPH038K613S0	6 15/16 in.																
TAAPH038K614S0	6 7/8 in.																
TAAPH038K615S0	6 9/16 in.																
TAAPH034K700S0	7 in.																
TAAPH040K180S0	180 mm	23140	179.3 7.06	380.5 14.98	250 9.84	492.3 19.38	549.4 21.63	107.0 4.25	628.6 24.75	206.2 8.12	49.3 1.94	M24 1	213.1 8.39	110 4.32	16.4 0.65	218 8.57	182 401
TAAPH040K702S0	7 1/8 in.																
TAAPH040K703S0	7 3/8 in.																
TAAPH040K704S0	7 1/4 in.																
TAAPH044K200S0	200 mm																
TAAPH044K713S0	7 13/16 in.																
TAAPH044K714S0	7 7/8 in.																
TAAPH044K715S0	7 15/16 in.																
TAAPH044K800S0	8 in.																
TAAPH048K220S0	220 mm	23148	209.5 8.25	459.7 18.10	300 11.81	571.5 22.50	635.0 25.00	127.0 5.00	749.3 29.50	203.2 8.00	89.9 3.54	M30 1 1/4	226.6 8.92	125 4.93	22.4 0.88	247 9.71	270 595
TAAPH048K807S0	8 7/8 in.																
TAAPH048K808S0	8 1/2 in.																
TAAPH048K815S0	8 15/16 in.																
TAAPH048K900S0	9 in.																
TAAPH052K240S0	240 mm	23152	241.3 9.5	512.1 20.16	330 12.99	628.6 24.75	708.1 27.88	133.3 5.25	831.8 32.75	236.2 9.30	76.2 3.00	M36 1 1/2	256.5 10.10	138.4 5.45	29.1 1.15	275 10.82	346 764
TAAPH052K907S0	9 7/8 in.																
TAAPH052K908S0	9 1/2 in.																

TAAPH0 SDAF 230-STYLE FOUR-BOLT PILLOW BLOCKS

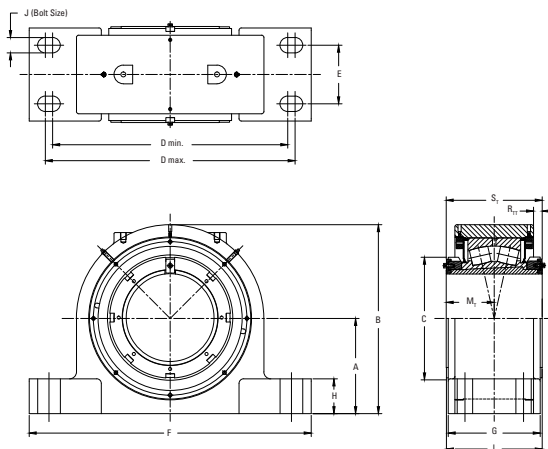

Bearing Part No. ⁽¹⁾	Shaft Dia.	Bearing No.	A	B	C	D min.	D max.	E	F	G	H	J	L	M _T	R _{TT}	S _T	Wt.
	mm in.		mm in.	mm in.	mm in.	mm in.	mm in.	mm in.	mm in.	mm in.	mm in.	mm in.	mm in.	mm in.	mm in.	mm in.	kg lbs.
TAAPH056K260S0	260 mm	23156	250.9 9.88	522.0 20.55	350 13.78	666.7 26.25	749.3 29.50	139.7 5.50	869.0 34.25	236.2 9.30	71.1 2.80	M36 1 ½	256.8 10.11	139 5.46	20.2 0.80	275 10.83	421 928
TAAPH056K915S0	9 15/16 in.																
TAAPH056K1000S0	10 in.																
TAAPH056K1007S0	10 7/16 in.																
TAAPH056K1008S0	10 ½ in.	23160	304.8 12.00	595.9 23.46	380 14.96	831.8 32.75	850.9 33.50	228.6 9.00	971.6 38.25	304.8 12.00	104.9 4.13	M42 1 ¾	297.9 11.73	146 5.73	146 5.73	287 11.29	569 1255
TAAPH060K280S0	280 mm																
TAAPH060K1015S0	10 15/16 in.																
TAAPH060K1100S0	11 in.																
TAAPH064K300S0	300 mm	23164	304.8 12.00	616.0 24.25	400 15.75	831.9 32.75	850.9 33.50	228.6 9.00	971.6 38.25	342.9 13.50	89.4 3.52	M42 1 ¾	327.1 12.88	156 6.13	19.8 0.78	307 12.07	618 1362
TAAPH064K1107S0	11 7/16 in.																
TAAPH064K1108S0	11 ½ in.																
TAAPH064K1115S0	11 15/16 in.																
TAAPH064K1200S0	12 in.	23168	304.8 12.00	645.6 25.42	440 17.32	812.8 32.00	850.9 33.50	254.0 10.00	990.6 39.00	349.3 13.75	64.3 2.53	M48 1 ¾	350.4 13.80	176 6.92	32.7 1.29	347 13.65	709 1564
TAAPH068K320S0	320 mm																
TAAPH068K1207S0	12 7/16 in.																
TAAPH068K1208S0	12 ½ in.																
TAAPH072K340S0	340 mm	23172	325.3 12.81	670.6 26.39	460 18.11	889.0 35.00	927.1 36.50	266.7 10.50	1060.4 41.75	368.3 14.50	72.1 2.84	M48 1 ¾	357.5 14.08	180 7.08	35.8 1.41	355 13.96	802 1770
TAAPH072K1215S0	12 15/16 in.																
TAAPH072K1300S0	13 in.																
TAAPH072K1307S0	13 7/16 in.																
TAAPH072K1308S0	13 ½ in.	23176	325.3 12.81	680.5 26.79	490 19.29	889.0 35.00	927.1 36.50	266.7 10.50	1060.4 41.75	342.9 13.50	115.0 4.53	M48 1 ¾	354.5 13.96	183 7.21	37.4 1.47	361 14.20	845 1863
TAAPH076K360S0	360 mm																
TAAPH076K1315S0	13 15/16 in.																
TAAPH076K1400S0	14 in.																
TAAPH080K380S0	380 mm	23180	368.3 14.50	763.3 30.05	520 20.47	996.9 39.25	1035.0 40.75	279.4 11.00	1168.4 46.00	406.4 16.00	94.5 3.72	M50 2	381.7 15.03	188 7.40	39.4 1.55	371 14.59	1126 2482
TAAPH080K1415S0	14 15/16 in.																
TAAPH080K1500S0	15 in.																

⁽¹⁾Insert size 23132K and above come standard with double nut tapered adapter

TAAPH1 SDAF 231-STYLE FOUR-BOLT PILLOW BLOCKS

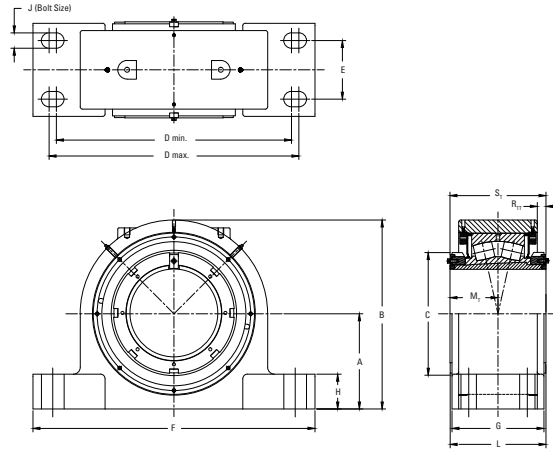

Bearing Part No. ⁽¹⁾	Shaft Dia.	Bearing No.	A	B	C	D min.	D max.	E	F	G	H	J	L	M _T	R _T	S _T	Wt.
	mm in.		mm in.	mm in.	mm in.	mm in.	mm in.	mm in.	mm in.	mm in.	mm in.	mm in.	mm in.	mm in.	mm in.	mm in.	kg lbs.
TAAPH152K240S0	240 mm	23152	260.3 10.25	531 20.91	330 12.99	736.6 29.00	774.7 30.50	222.2 8.75	889.0 35.00	298.5 11.75	95.0 3.74	M42 1 3/4	288 11.33	138 5.45	29 1.15	275 10.82	379 836
TAAPH152K907S0	9 7/16 in.																
TAAPH152K908S0	9 1/2 in.																
TAAPH156K260S0	260 mm	23156	304.8 12.00	576 22.67	350 13.78	762 30.00	851 33.50	228.6 9.00	971.5 38.25	330.2 13.00	101.6 4.00	M42 1 3/4	304 11.96	139 5.46	20 0.88	275 10.83	512 1130
TAAPH156K915S0	9 15/16 in.																
TAAPH156K1000S0	10 in.																
TAAPH156K1007S0	10 7/16 in.																
TAAPH156K1008S0	10 1/2 in.																
TAAPH160K280S0	280 mm	23160	304.8 12.00	596 23.46	380 14.96	831.8 32.75	850.9 33.50	228.6 9.00	971.6 38.25	305.0 12.00	104.9 4.33	M42 1 3/4	298 11.73	146 5.73	18 0.71	287 11.29	569 1255
TAAPH160K1015S0	10 15/16 in.																
TAAPH160K1100S0	11 in.																
TAAPH164K300S0	300 mm	23164	325.4 12.81	636 25.06	400 15.75	889.0 35.00	927.1 36.50	266.7 10.50	1060.5 41.75	342.9 13.50	109.9 4.33	M42 1 3/4	327 12.88	156 6.13	20 0.78	307 12.07	676 1490
TAAPH164K1107S0	11 7/16 in.																
TAAPH164K1108S0	11 1/2 in.																
TAAPH164K1115S0	11 15/16 in.																
TAAPH164K1200S0	12 in.																
TAAPH168K320S0	320 mm	23168	355.6 14.00	696 27.42	440 17.32	933.5 36.75	971.6 38.25	273.1 10.75	1111.3 43.75	349 13.75	115.0 4.53	M50 2	350 13.80	176 6.92	33 1.29	347 13.65	841 1855
TAAPH168K1207S0	12 7/16 in.																
TAAPH168K1208S0	12 1/2 in.																
TAAPH172K340S0	340 mm	23172	368.3 14.50	713 28.08	460 18.11	996.9 39.25	1035.0 40.75	279.4 11.00	1168.4 46.00	368.3 14.5	115.0 4.53	M50 2	358 14.08	180 7.08	36 1.41	355 13.96	920 2029
TAAPH172K1215S0	12 15/16 in.																
TAAPH172K1300S0	13 in.																
TAAPH172K1307S0	13 7/16 in.																
TAAPH172K1308S0	13 1/2 in.																
TAAPH176K360S0	360 mm	23176	368.3 14.50	729 28.71	490 19.29	996.9 39.25	1035.0 40.75	279.4 11.00	1168.4 46.00	368.3 14.5	115.0 4.53	M50 2	361 14.2	183 7.21	37 1.5	361 14.20	965 2128
TAAPH176K1315S0	13 15/16 in.																
TAAPH176K1400S0	14 in.																
TAAPH180K380S0	380 mm	23180	393.7 15.50	789 31.0	520 20.47	1060.4 41.75	1104.9 43.50	311.1 12.25	1238.2 48.75	406.4 16.00	119.9 4.72	M60 2 1/4	382 15.0	188 7.40	39 1.6	371 14.59	1205 2657
TAAPH180K1415S0	14 15/16 in.																
TAAPH180K1500S0	15 in.																

⁽¹⁾Insert size 23132K and above come standard with double nut tapered adapter

TAAPG SN-STYLE FOUR-BOLT PILLOW BLOCKS

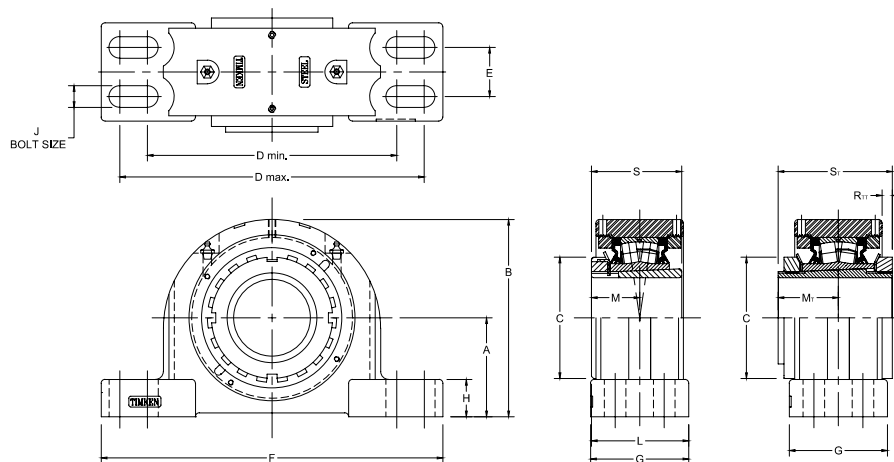

Bearing Part No.	Shaft Dia.	Bearing No.	A	B	C	D min.	D max.	E	F	G	H	J	L	M	M _T	R _T	S	S _T	Wt.
	mm in.		mm in.	mm in.	mm in.	mm in.	mm in.	mm in.	mm in.	mm in.	mm in.	mm in.	mm in.	mm in.	mm in.	mm in.	mm in.	mm in.	kg lbs.
TAPG11K115S TAAPG11K115S	1 15/16 in.	22211	69.9 2.75	134.9 5.31	74.9 2.95	182.4 7.18	217.4 8.56	39.9 1.57	251.0 9.88	68.6 2.70	31.8 1.25	16 5/8	69.9 2.75	35.6 1.40	39.1 1.54	7.1 0.28	58.9 2.32	76.33 3.01	8.6 19
TAPG11K200S TAAPG11K200S	2 in.																		
TAPG11K050S TAAPG11K050S	50 mm	22212	70.0 2.756	140.5 5.53	79.8 3.14	177.8 7.00	219.2 8.63	35.1 1.38	254.0 10.00	69.9 2.75	31.8 1.25	16 5/8	72.6 2.86	37.6 1.48	41.1 1.62	7.0 0.28	62.0 2.44	78.33 3.08	9.9 22
TAPG12K055S TAAPG12K055S	55 mm																		
TAPG13K203S TAAPG13K203S	2 3/16 in.	22213	80.0 3.15	154.9 6.10	85.1 3.35	182.4 7.18	217.4 8.56	48.0 1.89	261.9 10.31	82.6 3.25	35.1 1.38	16 5/8	81.0 3.19	39.6 1.56	43.7 1.72	5.1 0.20	65.0 2.56	82.83 3.26	11.3 25
TAPG13K204S TAAPG13K204S	2 1/4 in.																		
TAPG13K060S TAAPG13K060S	60 mm	22215	80.0 3.15	162.1 6.38	98.0 3.86	201.7 7.94	246.1 9.69	39.6 1.56	276.4 10.88	79.5 3.13	30.2 1.19	16 5/8	83.8 3.30	43.9 1.73	48.7 1.92	8.3 0.33	72.9 2.87	92.33 3.64	13.2 29
TAPG15K207S TAAPG15K207S	2 7/16 in.																		
TAPG15K208S TAAPG15K208S	2 1/2 in.	22216	95.0 3.74	180.3 7.10	104.6 4.12	235.0 9.25	266.7 10.50	50.0 1.97	315.0 12.40	89.9 3.54	31.8 1.25	16 5/8	92.5 3.64	47.5 1.87	51.7 2.04	11.3 0.45	78.0 3.07	99.33 3.91	14.9 33
TAPG15K065S TAAPG15K065S	65 mm																		
TAPG16K211S TAAPG16K211S	2 11/16 in.	22217	95.0 3.74	182.9 7.20	110.0 4.33	239.8 9.44	287.3 11.31	52.3 2.06	320.8 12.63	92.2 3.63	31.8 1.25	20 3/4	96.0 3.78	49.8 1.96	50.2 1.98	16.0 0.63	82.0 3.23	104.33 4.12	16.8 37
TAPG16K212S TAAPG16K212S	2 3/4 in.																		
TAPG16K070S TAAPG16K070S	70 mm	22218	100.0 3.937	195.3 7.69	119.6 4.71	282.7 11.13	298.5 11.75	50.0 1.97	344.9 13.58	100.1 3.94	39.6 1.56	16 5/8	102.1 4.02	52.1 2.05	56.6 2.23	12.3 0.49	86.1 3.39	108.83 4.28	24.5 54
TAPG17K215S TAAPG17K215S	2 15/16 in.																		
TAPG17K300S TAAPG17K300S	3 in.	22219	112.0 4.409	212.3 8.36	124.7 4.91	282.7 11.13	298.5 11.75	50.0 1.97	344.9 13.58	100.1 3.94	39.6 1.56	16 5/8	104.6 4.12	54.6 2.15	59.2 2.33	13.2 0.52	89.9 3.54	113.83 4.48	25.4 56
TAPG17K075S TAAPG17K075S	75 mm																		
TAPG18K080S TAAPG18K080S	80 mm	22219	112.0 4.409	212.3 8.36	124.7 4.91	282.7 11.13	298.5 11.75	50.0 1.97	344.9 13.58	100.1 3.94	39.6 1.56	16 5/8	104.6 4.12	54.6 2.15	59.2 2.33	13.2 0.52	89.9 3.54	113.83 4.48	25.4 56
TAPG18K303S TAAPG18K303S	3 3/16 in.																		
TAPG18K304S TAAPG18K304S	3 1/4 in.	22219	112.0 4.409	212.3 8.36	124.7 4.91	282.7 11.13	298.5 11.75	50.0 1.97	344.9 13.58	100.1 3.94	39.6 1.56	16 5/8	104.6 4.12	54.6 2.15	59.2 2.33	13.2 0.52	89.9 3.54	113.83 4.48	25.4 56
TAPG19K085S TAAPG19K085S	85 mm																		

Continued on next page.

TAAPG SN-STYLE FOUR-BOLT PILLOW BLOCKS – continued

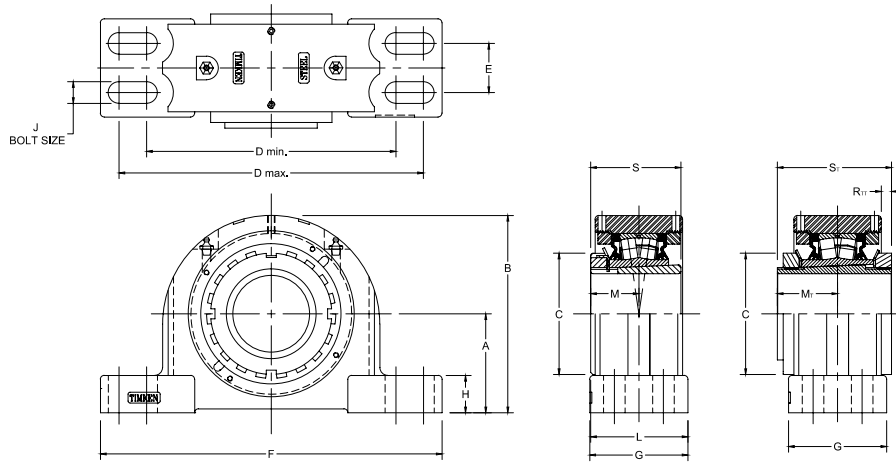

Continued from previous page.

Bearing Part No.	Shaft Dia.	Bearing No.	A	B	C	D min.	D max.	E	F	G	H	J	L	M	M _T	R _T	S	S _T	Wt.
	mm in.		mm in.	mm in.	mm in.	mm in.	mm in.	mm in.	mm in.	mm in.	mm in.	mm in.	mm in.	mm in.	mm in.	mm in.	mm in.	mm in.	kg lbs.
TAPG20K307S TAAPG20K307S	3 7/8 in.	22220	112.0	214.6	130.0	276.4	339.9	60.5	381.0	109.5	39.6	20	113.3	58.4	63.6	10.6	97.0	121.83	31.8
TAPG20K308S TAAPG20K308S	3 1/2 in.		4.409	8.45	5.12	10.88	13.38	2.38	15.00	4.31	1.56	3/4	4.46	2.30	2.51	0.42	3.82	4.80	70
TAPG20K090S TAAPG20K090S	90 mm	22222	125.0	238.3	145.0	301.8	368.3	69.9	406.4	120.7	44.5	20	123.4	63.0	65.8	14.1	104.9	130.7	39.5
TAPG22K315S TAAPG22K315S	3 15/16 in.		4.921	9.38	5.71	11.88	14.50	2.75	16.00	4.75	1.75	3/4	4.86	2.48	2.59	0.56	4.13	5.15	87
TAPG22K100S TAAPG22K100S	100 mm	22224	140.0	262.9	154.4	330.2	355.6	70.1	410.0	120.7	50.8	16	127.5	67.1	71.6	16.8	112.0	139.15	49.9
TAPG24K403S TAAPG24K403S	4 3/8 in.		5.512	10.35	6.08	13.00	14.00	2.76	16.14	4.75	2.00	5/8	5.02	2.64	2.82	0.66	4.41	5.48	110
TAPG24K110S TAAPG24K110S	110 mm	22226	150.0	281.7	165.1	367.28	400.1	81.0	444.5	128.0	49.3	24	135.9	71.88	76.6	20.4	120.9	149.65	61.7
TAPG26K407S TAAPG26K407S	4 7/8 in.		5.906	11.09	6.50	14.46	15.75	3.19	17.50	5.04	1.94	1	5.35	2.83	3.01	0.80	4.76	5.89	136
TAPG26K115S TAAPG26K115S	115 mm	22228	150.0	288.4	180.1	384.3	447.8	80.0	500.4	128.0	49.3	24	141.5	77.5	85.2	18.3	131.1	161.15	61.8
TAPG28K415S TAAPG28K415S	4 15/16 in.		5.906	11.36	7.09	15.13	17.63	3.15	19.70	5.04	1.94	1	5.57	3.05	3.35	0.72	5.16	6.34	136
TAPG28K500S TAAPG28K500S	5 in.	23130	150.0	288.4	180.1	384.3	447.8	80.0	500.4	128.0	49.3	24	141.5	77.5	85.2	18.3	131.1	161.15	61.8
TAPG28K125S TAAPG28K125S	125 mm		5.906	11.36	7.09	15.13	17.63	3.15	19.70	5.04	1.94	1	5.57	3.05	3.35	0.72	5.16	6.34	136
TAAPG30K503S	5 3/8 in.	23130	160.0	320.7	200.5	444.0	456.0	90.0	530.0	160.0	60.0	24	164.2	N/A	84.2	10.8	N/A	175.0	84
TAAPG30K504S	5 1/4 in.		6.30	12.62	7.89	17.48	17.95	3.54	20.87	6.30	2.36	1	6.46	N/A	3.32	0.43	N/A	6.89	185
TAAPG30K135S	135 mm		6.30	12.62	7.89	17.48	17.95	3.54	20.87	6.30	2.36	1	6.46	N/A	3.32	0.43	N/A	6.89	185

TAASN 3000 SERIES FOUR-BOLT PILLOW BLOCK

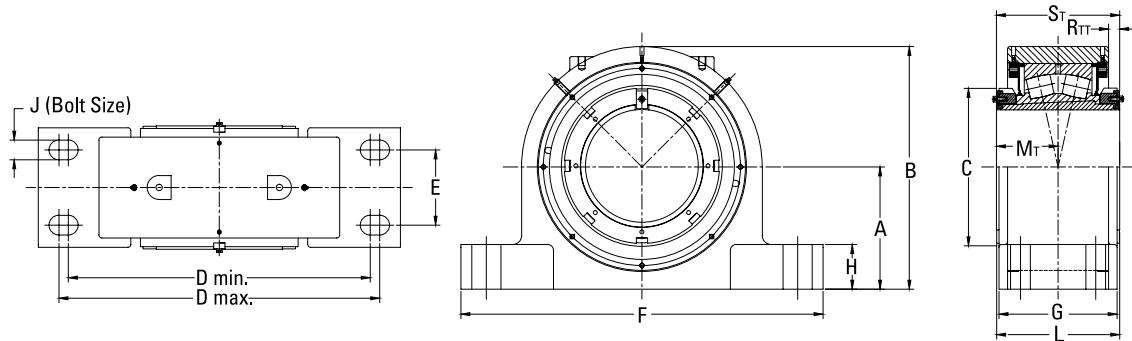

Bearing Part No. ⁽¹⁾	Shaft Dia.	Bearing No.	A	B	C	D min.	D max.	E	F	G	H	J	L	M _T	N	R _T	S _T	Wt.
			mm in.	mm in.	mm in.	mm in.	mm in.	mm in.	mm in.	mm in.	mm in.	mm in.	mm in.	mm in.	mm in.	mm in.	mm in.	mm in.
TAA30SN36K160SO	160 mm	23136	170 6.69	343 13.50	210 8.27	410 16.14	450 17.72	100 3.94	510 20.08	180 7.09	60 2.36	24 1	189 7.44	99 3.90	48 1.89	14 0.56	197 7.74	112 248
TAA30SN36K605SO	6 3/16 in.																	
TAA30SN36K606SO	6 3/8 in.																	
TAA30SN36K607SO	6 7/16 in.																	
TAA30SN36K608SO	6 1/2 in.																	
TAA30SN38K170SO	170 mm	23138	180 7.09	365 14.37	220 8.66	430 16.93	470 18.50	110 4.33	530 20.87	196 7.72	65 2.56	24 1	203 8.21	105 4.13	48 1.89	15 0.60	208 8.17	131 289
TAA30SN38K613SO	6 9/16 in.																	
TAA30SN38K614SO	6 7/8 in.																	
TAA30SN38K615SO	6 11/16 in.																	
TAA30SN38K700SO	7 in.																	
TAA30SN40K180SO	180 mm	23140	190 7.48	391 15.39	240 9.45	460 18.11	500 19.69	120 4.72	560 22.05	206 8.13	60 2.36	24 1	213 8.38	110 4.32	48 1.89	17 0.66	218 8.57	153 339
TAA30SN40K702SO	7 1/8 in.																	
TAA30SN40K703SO	7 3/16 in.																	
TAA30SN40K704SO	7 1/4 in.																	
TAA30SN44K200SO	200 mm																	
TAA30SN44K713SO	7 9/16 in.																	
TAA30SN44K714SO	7 7/8 in.																	
TAA30SN44K715SO	7 15/16 in.																	
TAA30SN44K800SO	8 in.																	
TAA30SN48K220SO	220 mm	23148	220 8.27	454 17.87	300 11.81	520 20.47	560 22.05	140 5.51	640 25.20	240 9.45	90 3.54	30 1 1/4	238 9.38	125 4.93	55 2.17	22 0.87	247 9.71	230 506
TAA30SN48K807SO	8 7/16 in.																	
TAA30SN48K808SO	8 1/2 in.																	
TAA30SN48K815SO	8 15/16 in.																	
TAA30SN48K900SO	9 in.																	
TAA30SN52K240SO	240 mm	23152	240 9.45	496 19.53	330 12.99	580 22.83	620 24.41	150 5.91	700 27.56	254 10	75 2.96	30 1 1/4	257 10.10	91 5.45	55 2.17	18 0.72	275 10.82	289 637
TAA30SN52K907SO	9 7/16 in.																	
TAA30SN52K908SO	9 1/2 in.																	

⁽¹⁾SN 3000 Series comes standard with double nut tapered adapter

Continued on next page.

TAASN 3000 SERIES FOUR-BOLT PILLOW BLOCK – continued

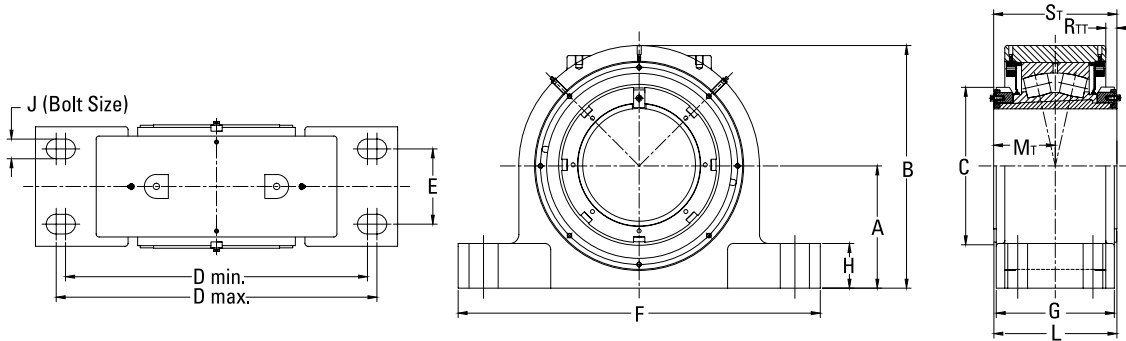

Continued from previous page.

Bearing Part No. ⁽¹⁾	Shaft Dia.	Bearing No.	A	B	C	D min.	D max.	E	F	G	H	J	L	M _T	N	R _T	S _T	Wt.	
	mm in.		mm in.	mm in.	mm in.	mm in.	mm in.	mm in.	mm in.	mm in.	mm in.	mm in.	mm in.	mm in.	mm in.	mm in.	mm in.	mm in.	kg lbs.
TAA30SN56K260SO	260 mm	23156	260 10.24	531 20.91	350 13.78	642 25.28	682 26.85	160 6.30	770 30.31	236 9.30	82 3.22	36 1 ½	257 10.11	139 5.46	62 2.44	20 0.80	275 10.83	358 790	
TAA30SN56K915SO	9 ⅝ in.																		
TAA30SN56K1000SO	10 in.																		
TAA30SN56K1007SO	10 ⅞ in.																		
TAA30SN56K1008SO	10 ½ in.	23160	280 11.02	571 22.48	380 14.96	650 25.59	690 27.17	160 6.30	790 31.10	266 10.48	105 4.13	36 1 ½	279 10.97	146 5.73	62 2.44	18 0.71	287 11.29	442 975	
TAA30SN60K280SO	280 mm																		
TAA30SN60K1015SO	10 ⅝ in.																		
TAA30SN60K1100SO	11 in.																		
TAA30SN64K300SO	300 mm	23164	300 11.81	611 24.06	400 15.75	690 27.17	730 28.74	190 7.48	830 32.68	276 10.87	90 3.54	36 1 ½	294 11.57	156 6.13	62 2.44	20 0.78	307 12.07	524 1156	
TAA30SN64K1107SO	11 ⅞ in.																		
TAA30SN64K1108SO	11 ½ in.																		
TAA30SN64K1115SO	11 ⅝ in.																		
TAA30SN64K1200SO	12 in.	23168	320 12.60	655 25.79	440 17.32	730 28.74	770 30.31	200 7.87	880 34.65	296 11.66	115 4.53	36 1 ½	324 12.75	176 6.92	62 2.44	33 1.29	347 13.65	634 1398	
TAA30SN68K320SO	320 mm																		
TAA30SN68K1207SO	12 ⅞ in.																		
TAA30SN68K1208SO	12 ½ in.																		
TAA30SN72K340SO	340 mm	23172	320 12.60	665 26.18	460 18.11	730 28.74	770 30.31	200 7.87	950 37.40	296 11.66	115 4.53	36 1 ½	328 12.91	180 7.08	62 2.44	36 1.40	355 13.96	760 1676	
TAA30SN72K1215SO	12 ⅝ in.																		
TAA30SN72K1300SO	13 in.																		
TAA30SN72K1307SO	13 ⅞ in.																		
TAA30SN72K1308SO	13 ½ in.	23176	340 13.39	695 27.36	490 19.29	790 31.10	830 32.68	220 8.66	1000 39.37	296 11.66	95 3.74	36 1 ½	331 13.04	183 7.21	62 2.44	37 1.47	361 14.20	838 1848	
TAA30SN76K360SO	360 mm																		
TAA30SN76K1315SO	13 ⅝ in.																		
TAA30SN76K1400SO	14 in.																		
TAA30SN80K380SO	380 mm	23180	350 13.78	745 29.33	520 20.47	820 32.28	860 33.86	220 8.66	1040 40.94	316 12.45	90 3.54	36 1 ½	346 13.63	188 7.40	62 2.44	39 1.55	371 14.59	921 2031	
TAA30SN80K1415SO	14 ⅝ in.																		
TAA30SN80K1500SO	15 in.																		

⁽¹⁾SN 3000 Series comes standard with double nut tapered adapter

TAASN 3100 SERIES FOUR-BOLT PILLOW BLOCK

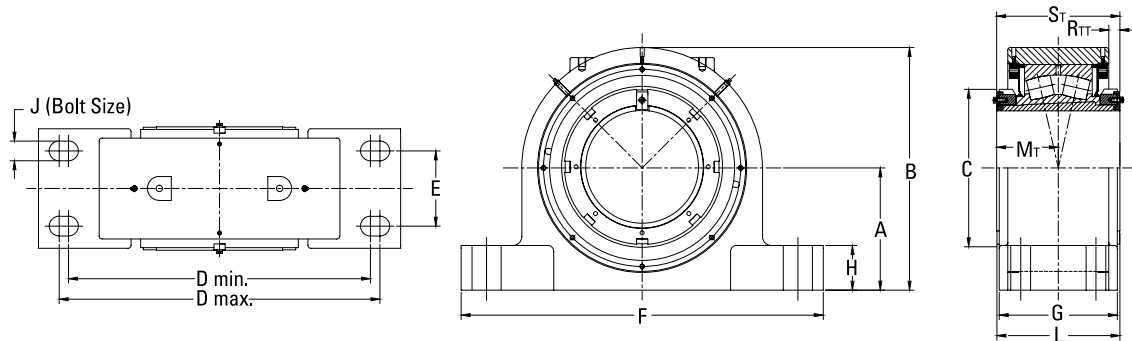

Bearing Part No. ⁽¹⁾	Shaft Dia.	Bearing No.	A	B	C	D min.	D max.	E	F	G	H	J (Bolt Size)	L	M _T	N	R _T	S _T	Wt.
			mm in.	mm in.	mm in.	mm in.	mm in.	mm in.	mm in.	mm in.	mm in.	mm in.	mm in.	mm in.	mm in.	mm in.	mm in.	mm in.
TAA31SN34K150S0	150 mm	23134	170 6.69	333 13.11	220 8.66	410 16.14	450 17.72	100 3.94	510 20.08	171.5 6.75	65 2.56	24 1	180 7.08	95 3.73	48 1.89	14 0.53	188 7.38	104 230
TAA31SN34K513S0	5 3/8 in.																	
TAA31SN34K514S0	5 7/8 in.																	
TAA31SN34K515S0	5 9/16 in.																	
TAA31SN34K600S0	6 in.																	
TAA31SN36K160S0	160 mm	23136	180 7.09	353 13.90	230 9.06	430 16.93	470 18.50	110 4.33	530 20.87	180 7.09	70 2.76	24 1	189 7.45	99 3.90	48 1.89	14 0.57	197 7.74	122 268
TAA31SN36K605S0	6 9/16 in.																	
TAA31SN36K606S0	6 3/8 in.																	
TAA31SN36K607S0	6 7/16 in.																	
TAA31SN36K608S0	6 1/2 in.																	
TAA31SN38K170S0	170 mm	23138	190 7.48	375 14.76	240 9.45	460 18.11	500 19.69	120 4.72	560 22.05	196.2 7.72	75 2.95	24 1	200 7.87	105 4.13	48 1.89	16 0.61	208 8.17	144 317
TAA31SN38K613S0	6 9/16 in.																	
TAA31SN38K614S0	6 7/8 in.																	
TAA31SN38K615S0	6 9/16 in.																	
TAA31SN38K700S0	7 in.																	
TAA31SN40K180S0	180 mm	23140	210 8.27	411 16.18	250 9.84	490 19.29	530 20.87	130 5.12	610 24.02	206 8.12	80 3.15	30 1 1/4	215 8.46	110 4.32	55 2.17	16 0.64	218 8.57	182 401
TAA31SN40K702S0	7 1/8 in.																	
TAA31SN40K703S0	7 3/16 in.																	
TAA31SN40K704S0	7 1/4 in.																	
TAA31SN44K200S0	200 mm																	
TAA31SN44K713S0	7 9/16 in.																	
TAA31SN44K714S0	7 7/8 in.																	
TAA31SN44K715S0	7 9/16 in.																	
TAA31SN44K800S0	8 in.																	
TAA31SN48K220S0	220 mm	23148	240 9.45	474 18.66	300 11.81	580 22.83	620 24.41	150 5.91	700 27.56	240 9.45	90 3.54	30 1 1/4	245 9.66	125 4.93	55 2.17	22 0.88	247 9.71	265 584
TAA31SN48K807S0	8 7/16 in.																	
TAA31SN48K808S0	8 1/2 in.																	
TAA31SN48K815S0	8 9/16 in.																	
TAA31SN48K900S0	9 in.																	

⁽¹⁾SN 3100 Series comes standard with double nut tapered adapter

Continued on next page.

TAASN 3100 SERIES FOUR-BOLT PILLOW BLOCK – continued

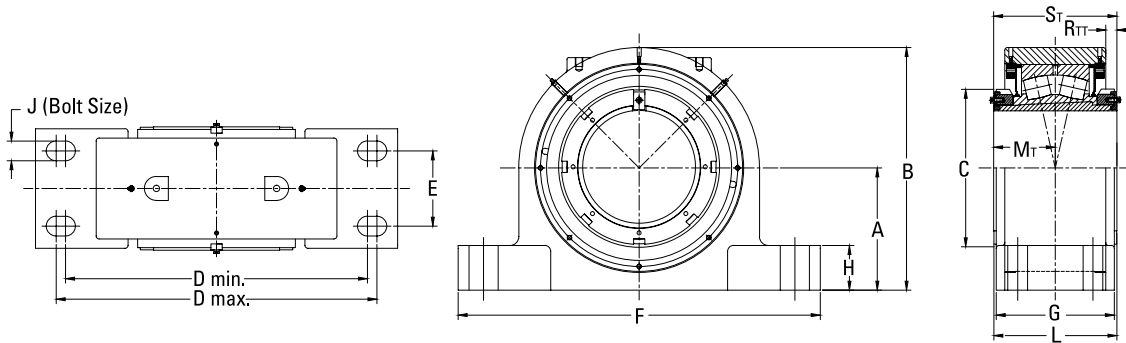

Continued from previous page.

Bearing Part No. ⁽¹⁾	Shaft Dia.	Bearing No.	A	B	C	D min.	D max.	E	F	G	H	J (Bolt Size)	L	M _T	N	R _{TT}	S _T	Wt.	
	mm in.		mm in.	mm in.	mm in.	mm in.	mm in.	mm in.	mm in.	mm in.	mm in.	mm in.	mm in.	mm in.	mm in.	mm in.	mm in.	kg lbs.	
TAA31SN52K240SO	240 mm	23152	260	530.6	330	642	682	160	770	236	95	36	265	91	62	29	275	327	
TAA31SN52K907SO	9 7/16 in.		10.24	20.89	12.99	25.28	26.85	6.30	30.31	9.30	3.74	1 1/2	10.45	5.45	2.44	1.15	10.82	721	
TAA31SN52K908SO	9 1/2 in.																		
TAA31SN56K260SO	260 mm	23156	280	551	350	650	690	160	790	236	100	36	266	139	62	20	275	403	
TAA31SN56K915SO	9 15/16 in.		11.02	21.69	13.78	25.59	27.17	6.30	31.10	9.30	3.94	1 1/2	10.46	5.46	2.44	0.80	10.83	888	
TAA31SN56K1000SO	10 in.																		
TAA31SN56K1007SO	10 7/16 in.																		
TAA31SN56K1008SO	10 1/2 in.																		
TAA31SN60K280SO	280 mm	23160	300	591	380	690	730	190	830	266	125	36	296	146	62	18	287	487	
TAA31SN60K1015SO	10 15/16 in.		11.81	23.27	14.96	27.17	28.74	7.48	32.68	10.48	4.92	1 1/2	11.63	5.73	2.44	0.71	11.29	1074	
TAA31SN60K1100SO	11 in.																		
TAA31SN64K300SO	300 mm	23164	320	631	400	730	770	200	880	276	110	36	311	156	62	20	307	573	
TAA31SN64K1107SO	11 7/16 in.		12.60	24.84	15.75	28.74	30.31	7.87	34.65	10.82	4.33	1 1/2	12.23	6.13	2.44	0.78	12.07	1263	
TAA31SN64K1108SO	11 1/2 in.																		
TAA31SN64K1115SO	11 15/16 in.																		
TAA31SN64K1200SO	12 in.																		
TAA31SN68K320SO	320 mm	23168	340	675	440	790	830	220	950	296	115	36	346	176	62	33	347	713	
TAA31SN68K1207SO	12 7/16 in.		13.39	26.57	17.32	31.10	32.68	8.66	37.40	11.66	4.53	1 1/2	13.62	6.92	2.44	1.29	13.65	1572	
TAA31SN68K1208SO	12 1/2 in.																		
TAA31SN72K340SO	340 mm	23172	350	695	460	820	860	220	1000	296	115	36	350	180	62	36	355	787	
TAA31SN72K1215SO	12 15/16 in.		13.78	27.36	18.11	32.28	33.86	8.66	39.37	11.66	4.53	1 1/2	13.77	7.08	2.44	1.41	13.96	1736	
TAA31SN72K1300SO	13 in.																		
TAA31SN72K1307SO	13 7/16 in.																		
TAA31SN72K1308SO	13 1/2 in.																		
TAA31SN76K360SO	360 mm	23176	360	715	490	850	890	220	1040	296	115	36	353	183	62	37	361	862	
TAA31SN76K1315SO	13 15/16 in.		14.17	28.15	19.29	33.46	35.04	8.66	40.94	11.66	4.53	1 1/2	13.90	7.21	2.44	1.47	14.20	1901	
TAA31SN76K1400SO	14 in.																		
TAA31SN80K380SO	380 mm	23180	380	775	520	930	970	240	1120	316	120	42	373	188	68	39	371	1088	
TAA31SN80K1415SO	14 15/16 in.		14.96	30.51	20.47	36.61	38.19	9.45	44.09	12.45	4.72	1 3/8	14.69	7.40	2.68	1.55	14.59	2398	
TAA31SN80K1500SO	15 in.																		

⁽¹⁾SN 3100 Series comes standard with double nut tapered adapter

DVC AND DAAC PILOTED FLANGE CARTRIDGES

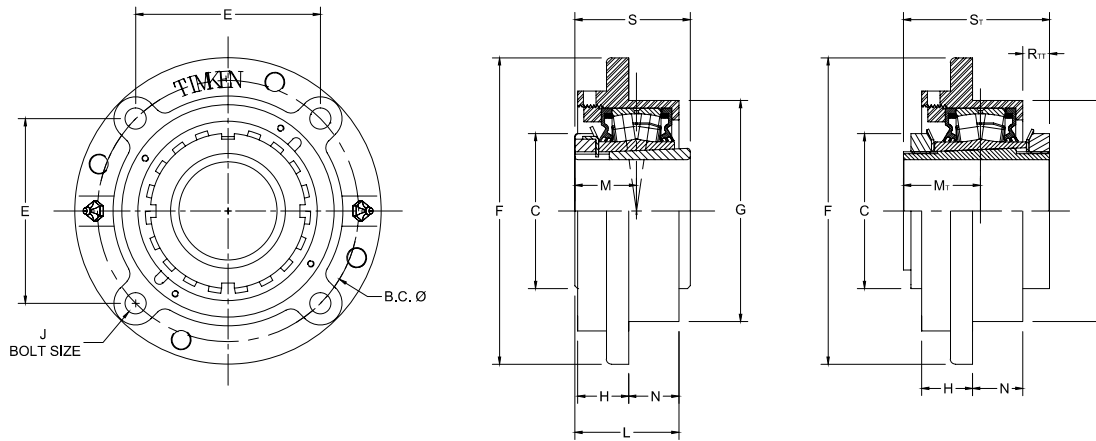

Bearing Part No.	Shaft Dia.	Bearing No.	B.C.	C	E	F	G ⁽¹⁾	H	I	J	L	M	M _T	N	R	R _{TT}	S	S _T	Wt.
	mm in.		mm in.	mm in.	mm in.	mm in.	mm in.	mm in.	mm in.	mm in.	mm in.	mm in.	mm in.	mm in.	mm in.	mm in.	mm in.	mm in.	kg lbs.
DVC09K107S DAAC09K107S	1 7/8 in.	22209	111.3 4.38	65.0 2.56	78.5 3.09	133.4 5.25	92.1 3.625	26.7 1.05	48.3 1.90	10 7/16	55.4 2.18	30.7 1.21	34.2 1.34	23.9 0.94	5.1 0.20	6.4 0.25	50.3 1.98	65.33 2.57	4.1 9
DVC09K108S DAAC09K108S	1 1/2 in.																		
DVC09K040S DAAC09K040S	40 mm																		
DVC10K111S DAAC10K111S	1 11/16 in.	22210	130.3 5.13	70.1 2.76	91.9 3.62	155.7 6.13	107.95 4.250	26.7 1.05	58.9 2.32	10 7/16	60.1 2.37	33.5 1.32	37.6 1.48	25.4 1.00	5.1 0.20	7.1 0.28	55.1 2.17	71.33 2.81	4.5 10
DVC10K112S DAAC10K112S	1 3/4 in.																		
DVC10K045S DAAC10K045S	45 mm																		
DVC11K115S DAAC11K115S	1 15/16 in.	22211	136.7 5.38	74.9 2.95	96.5 3.80	162.1 6.38	114.3 4.500	31.5 1.24	62.2 2.45	10 7/16	63.2 2.49	35.6 1.40	39.1 1.54	25.4 1.00	4.1 0.16	9.6 0.38	58.9 2.32	76.33 3.01	5.0 11
DVC11K200S DAAC11K200S	2 in.																		
DVC11K050S DAAC11K050S	50 mm																		
DVC13K203S DAAC13K203S	2 3/8 in.	22213	152.4 6.00	82.6 3.35	107.7 4.24	181.1 7.13	127.0 5.000	37.3 1.47	84.8 3.34	12 1/2	65.5 2.58	39.6 1.56	43.7 1.72	25.4 1.00	-2.8 -0.11	13.2 0.52	65.0 2.56	82.83 3.26	7.3 16
DVC13K204S DAAC13K204S	2 1/4 in.																		
DVC13K060S DAAC13K060S	60 mm																		
DVC15K207S DAAC15K207S	2 7/8 in.	22215	165.1 6.50	98.0 3.86	116.8 4.60	193.8 7.63	139.7 5.500	32.3 1.27	79.0 3.11	12 1/2	69.9 2.75	43.9 1.73	48.7 1.92	31.8 1.25	3.6 0.14	17.6 0.69	72.9 2.87	92.33 3.64	8.2 18
DVC15K208S DAAC15K208S	2 1/2 in.																		
DVC15K065S DAAC15K065S	65 mm																		
DVC17K215S DAAC17K215S	2 15/16 in.	22217	190.5 7.50	110.0 4.33	134.6 5.30	222.3 8.75	161.9 6.375	32.5 1.28	90.2 3.55	16 5/8	79.8 3.14	49.8 1.96	50.2 1.98	35.1 1.38	2.3 0.09	24.1 0.95	82.0 3.23	104.33 4.12	11.3 25
DVC17K300S DAAC17K300S	3 in.																		
DVC17K075S DAAC17K075S	75 mm																		

Continued on next page.

DVC AND DAAC PILOTED FLANGE CARTRIDGES – continued

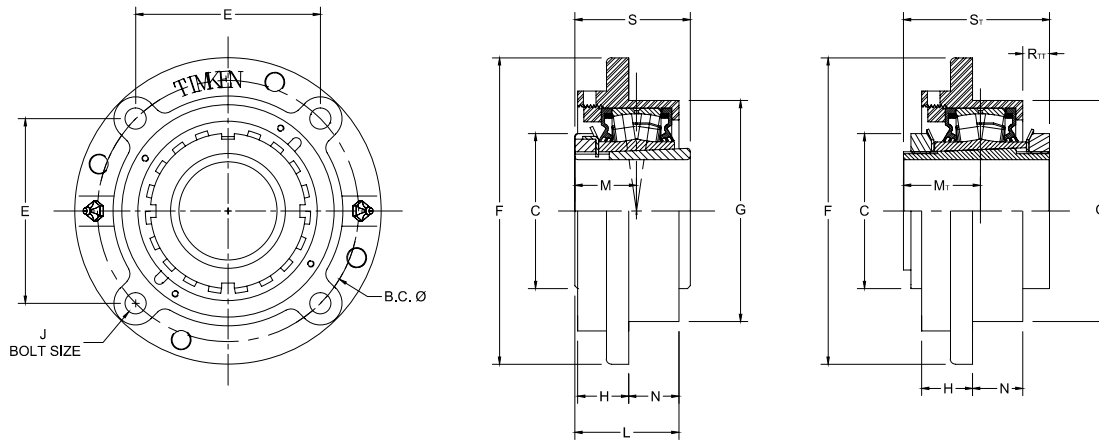

Bearing Part No.	Shaft Dia.	Bearing No.	B.C.	C	E	F	G ⁽¹⁾	H	I	J	L	M	M _T	N	R	R _{TT}	S	S _T	Wt.	
	mm in.		mm in.	mm in.	mm in.	mm in.	mm in.	mm in.	mm in.	mm in.	mm in.	mm in.	mm in.	mm in.	mm in.	mm in.	mm in.	mm in.	mm in.	kg lbs.
DVC20K307S DAAC20K307S	3 7/16 in.	22220	219.2 8.63	130.0 5.12	154.9 6.10	260.4 10.25	187.3 7.375	41.1 1.62	106.2 4.18	20 3/4	91.9 3.62	58.4 2.30	63.6 2.51	35.1 1.38	5.1 0.20	24.7 0.97	97.0 3.82	121.83 4.80	16.8 37	
DVC20K308S DAAC20K308S	3 1/2 in.																			
DVC20K090S DAAC20K090S	90 mm																			
DVC22K315S DAAC22K315S	3 15/16 in.	22222	238.3 9.38	145.0 5.71	168.4 6.63	276.4 10.88	206.4 8.125	48.0 1.89	116.8 4.60	20 3/4	100.1 3.94	63.0 2.48	65.8 2.59	38.1 1.50	4.6 0.18	27.8 1.09	104.9 4.13	130.7 5.15	26.3 58	
DVC22K400S DAAC22K400S	4 in.																			
DVC22K100S DAAC22K100S	100 mm																			
DVC26K407S ⁽²⁾ DAAC26K407S ⁽²⁾	4 7/16 in.	22226	298.5 11.75 ⁽²⁾	165.1 6.50	149.4 5.88 ⁽²⁾	342.9 13.50	260.4 10.250	47.0 1.85	137.9 5.43	20 3/4 ⁽²⁾	116.8 4.60	71.9 2.83	76.6 3.01	48.3 1.90	4.1 0.16	28.2 1.11	120.9 4.76	149.65 5.89	34.5 76	
DVC26K408S ⁽²⁾ DAAC26K408S ⁽²⁾	4 1/2 in.																			
DVC26K115S ⁽²⁾ DAAC26K115S ⁽²⁾	115 mm																			

⁽¹⁾Pilot tolerance: +0/-0.05 mm (+0/-0.002 in.).

⁽²⁾Six-bolt housing.

TACK AND TAACK PILOTED FLANGE CARTRIDGES

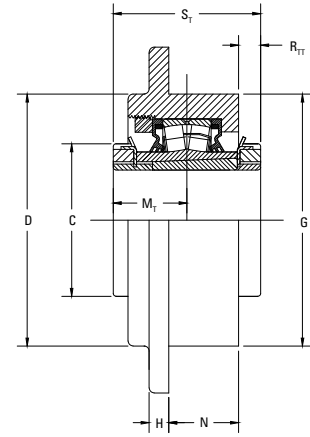
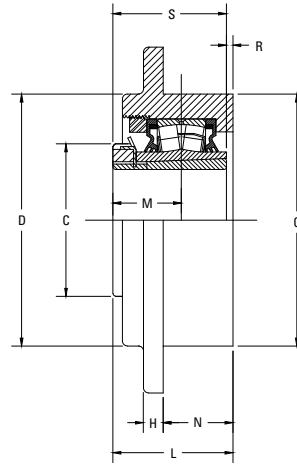
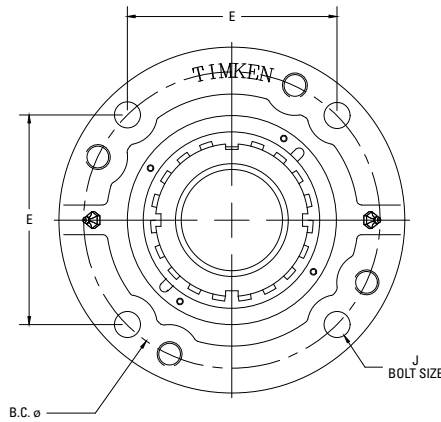

Bearing Part No. ⁽¹⁾	Shaft Dia.	Bearing No.	B.C.	C	D	E	F	G ⁽²⁾	H	J	L	M	M _T	N	R	R _T	S	S _T	Wt.
TACK10K045S TAACK10K045S	45 mm	22210	152.4 6.00	70.0 2.76	127.0 5.00	107.7 4.24	181.1 7.13	127.0 5.000	12.4 0.50	12 ½	60.1 2.37	33.5 1.32	37.6 1.48	25.4 1.00	-5.1 -0.20	7.1 0.28	55.0 2.17	71.3 2.81	3.8 8.4
TACK11K115S TAACK11K115S	1 15/16 in.	22211	152.4 6.00	75.0 2.95	127.0 5.00	107.7 4.24	181.1 7.13	127.0 5.000	14.2 0.56	12 ½	71.9 2.83	35.5 1.40	39.1 1.54	39.7 1.56	-13.0 -0.51	1.0 0.04	59.0 2.32	76.3 3.01	5.8 12.8
TACK11K200S TAACK11K200S	2 in.																		
TACK11K050S TAACK11K050S	50 mm	22212	165.1 6.50	80.0 3.15	139.7 5.50	116.7 4.60	193.8 7.63	139.7 5.500	12.4 0.50	12 ½	67.6 2.66	37.5 1.48	41.1 1.62	25.4 1.00	-5.6 -0.22	7.1 0.28	62.0 2.44	78.3 3.08	7.4 16.4
TACK12K055S TAACK12K055S	55 mm																		
TACK13K203S TAACK13K203S	2 3/8 in.	22213	165.1 6.50	85.0 3.35	139.7 5.50	116.7 4.60	193.8 7.63	139.7 5.500	12.4 0.50	12 ½	78.0 3.07	39.5 1.55	43.7 1.72	42.9 1.69	-13.0 -0.51	0.5 0.02	65.0 2.56	82.8 3.26	8.5 18.8
TACK13K204S TAACK13K204S	2 ¼ in.																		
TACK15K207S TAACK15K207S	2 7/8 in.	22215	190.5 7.50	85.0 3.35	162.1 6.38	134.7 5.30	222.3 8.75	161.9 6.375	16.0 0.63	16 5/8	82.7 3.26	44.0 1.73	48.7 1.92	47.6 1.88	-9.9 -0.39	4.6 0.18	73.0 2.87	92.3 3.63	9.6 21.1
TACK15K208S TAACK15K208S	2 ½ in.																		
TACK16K211S TAACK16K211S	2 11/16 in.	22216	219.2 8.63	105.0 4.13	187.5 7.38	154.9 6.10	260.4 10.25	187.3 7.375	19.1 0.75	20 ¾	79.0 3.11	47.5 1.87	49.7 1.96	34.9 1.38	-1.0 -0.04	18.0 0.71	78.0 3.07	99.3 3.91	11.7 25.8
TACK17K215S TAACK17K215S	2 15/16 in.	22217	219.2 8.63	110.0 4.33	187.5 7.38	154.9 6.10	260.4 10.25	187.3 7.375	19.1 0.75	20 ¾	80.5 3.17	50.0 1.97	51.7 2.03	34.9 1.38	1.5 0.06	22.4 0.88	82.0 3.23	104.3 4.11	13.8 30.5
TACK17K300S TAACK17K300S	3 in.																		
TACK17K075S TAACK17K075S	75 mm	22218	238.3 9.38	120.0 4.72	203.2 8.00	168.4 6.63	276.4 10.88	206.5 8.125	19.1 0.75	20 ¾	86.9 3.42	52.0 2.05	54.4 2.14	34.9 1.38	-0.8 -0.03	19.6 0.77	86.0 3.39	108.8 4.28	15.9 35.1
TACK18K303S TAACK18K303S	3 3/8 in.																		
TACK18K080S TAACK18K080S	80 mm	22220	238.3 9.38	130.0 5.12	206.5 8.13	168.4 6.63	276.4 10.88	206.5 8.125	25.4 1.00	20 ¾	110.1 4.33	59.4 2.34	62.7 2.47	57.2 2.25	-13.0 -0.51	8.6 0.34	97.0 3.82	121.8 4.80	26.9 59.2
TACK20K307S TAACK20K307S	3 7/8 in.																		
TACK22K315S ⁽³⁾ TAACK22K315S ⁽³⁾	3 15/16 in.	22222	298.5 11.75	145.0 5.71	260.4 10.25	149.2 5.88 ⁽²⁾	342.9 13.50	260.4 10.250	25.4 1.00	20 ¾ ⁽²⁾	119.1 4.69	63.0 2.48	67.7 2.67	68.1 2.68	-14.2 -0.56	6.9 0.27	105.0 4.13	130.7 5.15	37.8 83.4
TACK22K400S ⁽³⁾ TAACK22K400S ⁽³⁾	4 in.																		
TACK22K100S ⁽³⁾ TAACK22K100S ⁽³⁾	100 mm	22224	323.9 12.75	155.0 6.10	260.4 10.25	161.9 6.38 ⁽²⁾	374.7 14.75	279.4 11.000	25.4 1.00	24 7/8 ⁽²⁾	115.9 4.56	67.0 2.64	70.3 2.77	48.3 1.90	-3.81 -0.15	20.1 0.79	112.0 4.41	139.2 5.48	41.6 91.8
TACK24K403S ⁽³⁾ TAACK24K403S ⁽³⁾	4 3/8 in.																		
TACK24K404S ⁽³⁾ TAACK24K404S ⁽³⁾	4 ¼ in.																		

⁽¹⁾ Double-nut (TAA/DAA) part number shown. Single-nut (TA/DV) version available upon request.

⁽²⁾ Pilot tolerance: +0/-0.05 mm (+0/-0.002 in.).

⁽³⁾ Six-bolt housing.

Continued on next page.

TACK AND TAACK PILOTED FLANGE CARTRIDGES – continued

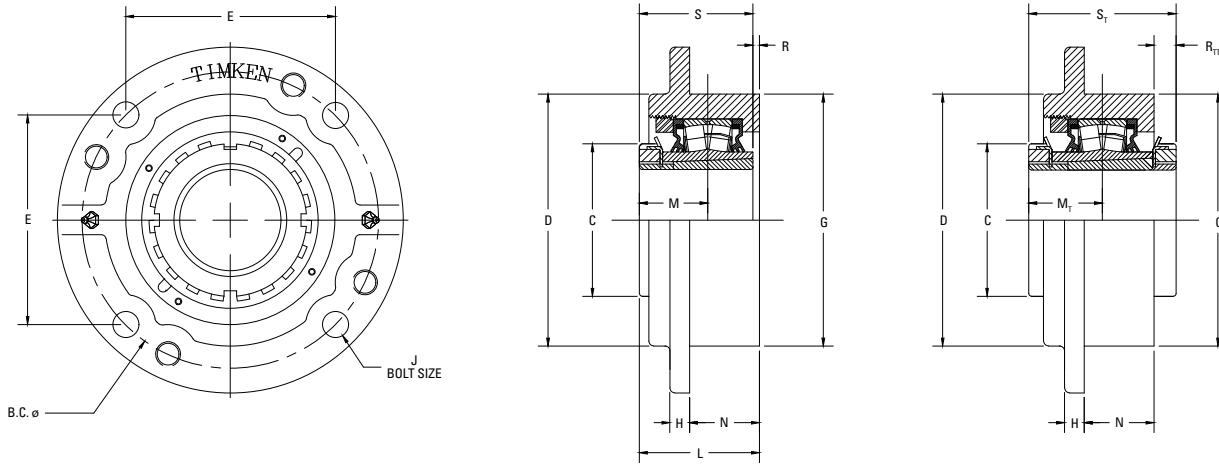

Bearing Part No. ⁽¹⁾	Shaft Dia.	Bearing No.	B.C.	C	D	E	F	G ⁽²⁾	H	J	L	M	M _T	N	R	R _T	S	S _T	Wt.	
	mm in.		mm in.	mm in.	mm in.	mm in.	mm in.	mm in.	mm in.	mm in.	mm in.	mm in.	mm in.	mm in.	mm in.	mm in.	mm in.	mm in.	mm in.	kg lbs.
TACK26K407S ⁽³⁾ TAACK26K407S ⁽³⁾	4 7/16 in.	22226	323.9 12.75	165.0 6.50	266.7 10.50	161.9 6.38 ⁽²⁾	374.7 14.75	279.4 11.000	25.4 1.00	24 7/8 ⁽²⁾	129.8 5.11	72.0 2.83	76.6 3.01	77.9 3.07	-8.9 -0.35	15.2 0.60	121.0 4.76	149.7 5.89	45.4 100.2	
TACK28K415S ⁽³⁾ TAACK28K415S ⁽³⁾	4 15/16 in.	22228	368.3 14.50	180.0 7.09	304.8 12.00	184.2 7.25	431.8 17.00	330.2 13.000	25.4 1.00	24 7/8 ⁽²⁾	133.5 5.25	77.5 3.05	85.3 3.36	65.0 2.56	-2.3 -0.09	20.1 0.79	131.0 5.16	161.2 6.35	83.1 183.3	
TACK28K500 ⁽³⁾ TAACK28K500S ⁽³⁾	5 in.																			
TACK32K507S ⁽³⁾ TAACK32K507S ⁽³⁾	5 7/16 in.	23132	419.1 16.50	210.0 8.27	330.2 13.00	209.6 8.25	482.6 19.00	355.6 14.000	31.8 1.25	M24 1 ⁽²⁾	173.2 6.82	-	90.5 3.56	104.9 4.13	-	11.7 0.46	-	185.0 7.28	110.7 244	
TACK34K515S ⁽³⁾ TAACK34K515S ⁽³⁾	5 15/16 in.	23134	431.8 17.00	220.0 8.66	355.6 14.00	215.9 8.50	482.6 19.00	381.0 15.000	31.8 1.25	M24 1 ⁽²⁾	177.3 6.98	-	94.6 3.73	104.9 4.13	-	9.4 0.37	-	186.7 7.35	112.5 248	
TACK34K600S ⁽³⁾ TAACK34K600S ⁽³⁾	6 in.																			
TACK36K607S ⁽³⁾ TAACK36K607S ⁽³⁾	6 7/16 in.	23136	431.8 17.00	230.0 9.06	355.6 14.00	215.9 8.50	482.6 19.00	381.0 15.000	31.8 1.25	M24 1 ⁽²⁾	182.3 7.18	-	98.9 3.90	104.9 4.13	-	14.2 0.56	-	196.7 7.74	130.4 287.4	

⁽¹⁾Double-nut (TAA/DAA) part number shown. Single-nut (TA/DV) version available upon request.

⁽²⁾Pilot tolerance: +0/-0.05 mm (+0/-0.002 in.).

⁽³⁾Six-bolt housing.

T AFC AND TAAFC SQUARE PILOTED FLANGE CARTRIDGES

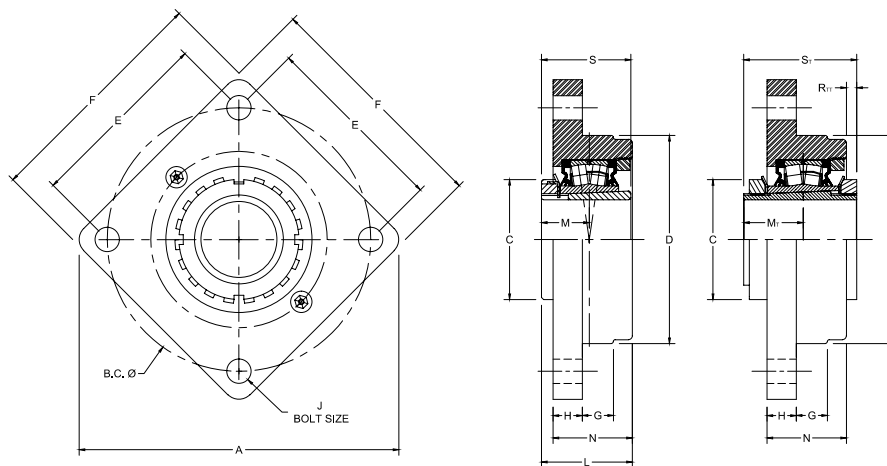

Bearing Part No.	Shaft Dia.	Bearing No.	A	B.C.	C	D ⁽¹⁾	E	F	G	H	J	L	M	M _T	N	R _{TT}	S	S _T	Wt.	
	mm in.		mm in.	mm in.	mm in.	mm in.	mm in.	mm in.	mm in.	mm in.	mm in.	mm in.	mm in.	mm in.	mm in.	mm in.	mm in.	mm in.	mm in.	kg lbs.
T AFC15K2075 TAAFC15K2075	2 7/16 in.	22215	255.0 10.04	215.1 8.47	98.0 3.86	169.9 6.690	152.4 6.00	192.0 7.56	25.4 1.00	23.9 0.94	16 5/8	79.5 3.13	43.9 1.73	48.7 1.92	64.8 2.55	8.0 0.32	72.9 2.87	92.33 3.64	11.3 25	
T AFC15K2085 TAAFC15K2085	2 1/2 in.																			
T AFC15K0655 TAAFC15K0655	65 mm	22217	282.4 11.12	240.0 9.45	110.0 4.33	190.0 7.480	169.7 6.68	212.1 8.35	25.4 1.00	25.4 1.00	16 5/8	88.6 3.49	49.8 1.96	50.2 1.98	69.9 2.75	15.3 0.60	82.0 3.23	104.33 4.12	13.6 30	
T AFC17K2155 TAAFC17K2155	2 15/16 in.																			
T AFC17K3005 TAAFC17K3005	3 in.	22220	330.2 13.00	279.9 11.02	130.0 5.12	230.1 9.060	197.9 7.79	247.9 9.76	31.8 1.25	28.7 1.13	20 3/4	105.7 4.16	58.4 2.30	63.6 2.51	94.2 3.71	10.9 0.43	97.0 3.82	121.83 4.80	18.1 40	
T AFC17K0755 TAAFC17K0755	75 mm																			
T AFC20K3075 TAAFC20K3075	3 7/16 in.	22222	367.0 14.45	309.9 12.20	145.0 5.71	255.0 10.039	219.2 8.63	274.3 10.80	44.5 1.75	26.4 1.04	20 3/4	113.0 4.45	63.0 2.48	65.8 2.59	101.1 3.98	14.9 0.59	104.9 4.13	130.7 5.15	27.2 60	
T AFC20K3085 TAAFC20K3085	3 1/2 in.																			
T AFC20K0905 TAAFC20K0905	90 mm	22226	411.5 16.20	355.1 13.98	165.1 6.50	290.0 11.417	251.0 9.88	298.5 11.75	41.9 1.65	32.0 1.26	24 7/8	130.6 5.14	71.9 2.83	76.6 3.01	114.3 4.50	14.4 0.56	120.9 4.76	149.65 5.89	42.6 94	
T AFC22K3155 TAAFC22K3155	3 15/16 in.																			
T AFC22K4005 TAAFC22K4005	4 in.	22226	411.5 16.20	355.1 13.98	165.1 6.50	290.0 11.417	251.0 9.88	298.5 11.75	41.9 1.65	32.0 1.26	24 7/8	130.6 5.14	71.9 2.83	76.6 3.01	114.3 4.50	14.4 0.56	120.9 4.76	149.65 5.89	42.6 94	
T AFC22K1005 TAAFC22K1005	100 mm																			
T AFC26K4075 TAAFC26K4075	4 7/16 in.	22226	411.5 16.20	355.1 13.98	165.1 6.50	290.0 11.417	251.0 9.88	298.5 11.75	41.9 1.65	32.0 1.26	24 7/8	130.6 5.14	71.9 2.83	76.6 3.01	114.3 4.50	14.4 0.56	120.9 4.76	149.65 5.89	42.6 94	
T AFC26K4085 TAAFC26K4085	4 1/2 in.																			
T AFC26K1155 TAAFC26K1155	115 mm																			

⁽¹⁾Pilot tolerance: +0/-0.05 mm (+0/-0.002 in.).

TAFB AND TAAFB SQUARE FLANGE BLOCKS

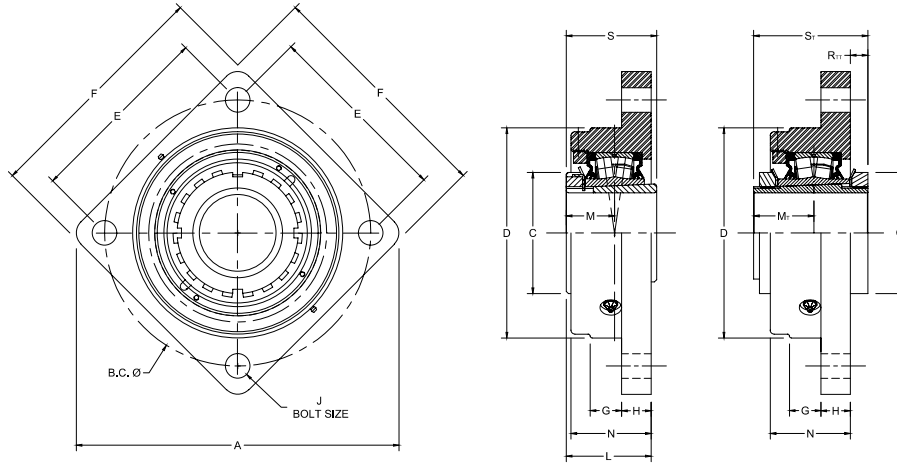

Bearing Part No.	Shaft Dia.	Bearing No.	A	B.C.	C	D	E	F	G	H	J	L	M	M _T	N	R _{TT}	S	S _T	Wt.	
	mm in.		mm in.	mm in.	mm in.	mm in.	mm in.	mm in.	mm in.	mm in.	mm in.	mm in.	mm in.	mm in.	mm in.	mm in.	mm in.	mm in.	mm in.	kg lbs.
TAFB15K207S TAAFB15K207S	2 7/16 in.	22215	255.0 10.04	215.1 8.47	98.0 3.86	169.9 6.69	152.4 6.00	192.0 7.56	25.4 1.00	23.9 0.94	16 5/8	73.7 2.90	43.9 1.73	48.7 1.92	64.8 2.55	13.8 0.54	72.9 2.87	92.33 3.64	11.3 25	
TAFB15K208S TAAFB15K208S	2 1/2 in.																			
TAFB15K065S TAAFB15K065S	65 mm																			
TAFB17K215S TAAFB17K215S	2 15/16 in.	22217	282.4 11.12	240.0 9.45	110.0 4.33	190.0 7.48	169.7 6.68	212.1 8.35	25.4 1.00	25.4 1.00	16 5/8	88.6 3.49	49.8 1.96	50.2 1.98	69.9 2.75	15.3 0.60	82.0 3.23	104.33 4.12	13.6 30	
TAFB17K300S TAAFB17K300S	3 in.																			
TAFB17K075S TAAFB17K075S	75 mm																			
TAFB20K307S TAAFB20K307S	3 7/16 in.	22220	330.2 13.00	280.0 11.02	130.0 5.12	230.1 9.06	197.9 7.79	247.9 9.76	31.8 1.25	28.7 1.13	20 3/4	105.7 4.16	58.4 2.30	63.6 2.51	94.2 3.71	10.9 0.43	97.0 3.82	121.83 4.80	18.1 40	
TAFB20K308S TAAFB20K308S	3 1/2 in.																			
TAFB20K090S TAAFB20K090S	90 mm																			
TAFB22K315S TAAFB22K315S	3 15/16 in.	22222	367.0 14.45	309.9 12.20	145.0 5.71	255.0 10.04	219.2 8.63	279.4 11.00	44.5 1.75	26.4 1.04	20 3/4	113.0 4.45	63.0 2.48	65.8 2.59	101.1 3.98	14.9 0.59	104.9 4.13	130.7 5.15	27.2 60	
TAFB22K400S TAAFB22K400S	4 in.																			
TAFB22K100S TAAFB22K100S	100 mm																			
TAFB26K407S TAAFB26K407S	4 7/16 in.	22226	411.5 16.20	354.8 13.97	165.1 6.50	290.0 11.42	251.0 9.88	298.5 11.75	41.9 1.65	32.0 1.26	24 7/8	130.6 5.14	71.9 2.83	76.6 3.01	114.3 4.50	14.4 0.56	120.9 4.76	149.65 5.89	42.6 94	
TAFB26K408S TAAFB26K408S	4 1/2 in.																			
TAFB26K115S TAAFB26K115S	115 mm																			

TAFNL SERIES SQUARE FLANGE BLOCKS - TAPERED BORE EQUIVALENT

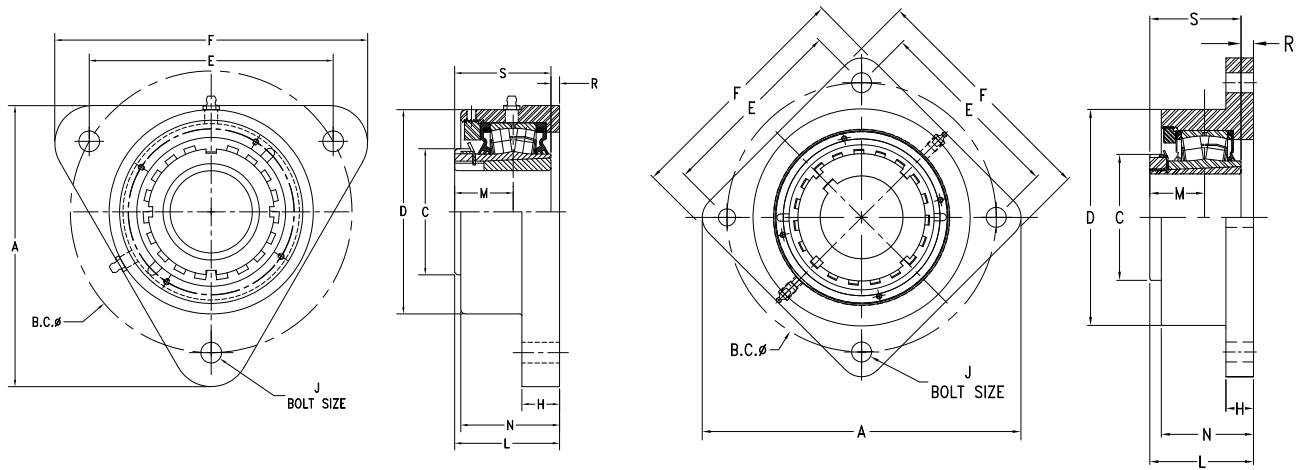

Bearing Part No.	Shaft Dia.	Bearing No.	A	B.C	C	D	E	F	H	J	L	M	N	R	S	Wt.
			mm in.	mm in.	mm in.	mm in.	mm in.	mm in.	mm in.	mm in.	mm in.	mm in.	mm in.	mm in.	mm in.	mm in.
TAFNL09K040S TAFNL09K107S TAFNL09K108S	40 mm	22209	161.5	160.0	65	118.4	138.6	179	12	12	57.0	30.8	53.2	19.6	50.3	4.0
	1 7/16 in.		6.36	6.3	2.56	4.66	5.46	7.05	0.47	1/2	2.24	1.21	2.10	0.77	1.98	8.8
	1 1/2 in.															
TAFNL10K045S TAFNL10K111S TAFNL10K112S	45 mm	22210	161.5	160	70	118.4	138.6	179	15	12	62.6	33.6	56.2	21.3	54.8	5.0
	1 7/16 in.		6.36	6.3	2.76	4.66	5.46	7.05	0.59	1/2	2.46	1.32	2.21	0.84	2.16	11
	1 3/4 in.															
TAFNL11K050S TAFNL11K115S TAFNL11K200S	50 mm	22211	172.3	170	75	121.9	147.2	192	15	12	65.1	35.5	60.0	23.4	59	5.0
	1 9/16 in.		6.78	6.69	2.95	4.8	5.8	7.56	0.59	1/2	2.56	1.40	2.36	0.92	2.32	11
	2 in.															
TAFNL12K055S	55 mm	22212	173.2	180	80	127.0	155.9	210	15	12	67.8	37.5	59.0	24.4	62	5.4
			6.82	7.09	3.15	5.00	6.14	8.27	0.59	1/2	2.67	1.48	2.32	0.96	11.9	11
TAFNL13K060S TAFNL13K203S TAFNL13K204S	60 mm	22213	200.2	190	85	137.8	164.5	223.3	15	12	70.8	39.5	66.6	25.7	65	6.3
	2 3/8 in.		7.88	7.48	3.35	5.43	6.48	8.79	0.59	1/2	2.79	1.55	2.62	1.01	2.56	13.9
	2 1/4 in.															
TAFNL15K065S TAFNL15K207S TAFNL15K208S	65 mm	22215	258.2	215.0	98.0	169.9	152.0	190.0	25	16	74.0	44.0	65.4	29	73.0	11.3
	2 5/8 in.		10.16	8.46	3.86	6.69	5.98	7.48	0.98	5/8	2.91	1.73	2.58	1.14	2.87	25
	2 1/2 in.															
TAFNL16K070S TAFNL16K211S TAFNL16K212S	70 mm	22216	258.2	215.0	105.0	170.0	152.0	190.0	25	16	79.2	47.5	65.4	30.5	78.0	11.3
	2 7/8 in.		10.16	8.46	4.13	6.69	5.98	7.48	0.98	5/8	3.12	1.87	2.58	1.20	3.07	25
	2 3/4 in.															
TAFNL17K075S TAFNL17K215S TAFNL17K300S	75 mm	22217	279.4	240.0	110.0	190.0	170.0	210.0	25	16	86.9	50.0	73.1	32.0	82.0	13.6
	2 9/16 in.		11.00	9.47	4.33	7.48	6.69	8.27	0.98	5/8	3.42	1.97	2.88	1.26	3.23	30
	3 in.															
TAFNL18K080S TAFNL18K303S TAFNL18K304S	80 mm	22218	279.4	240.0	120.0	190.0	170.0	210.0	25.0	16	87.4	52.0	73.1	34	86.0	13.6
	3 1/8 in.		11.00	9.47	4.72	7.48	6.69	8.27	0.98	5/8	3.44	2.05	2.88	1.34	3.39	30
	3 1/4 in.															
TAFNL20K090S TAFNL20K307S TAFNL20K308S	90 mm	22220	332.5	279.9	130.0	198.1	197.9	250.0	30.0	20	103.4	59.4	90.8	37.6	97.0	18.1
	3 5/8 in.		13.09	11.02	5.12	7.80	7.79	9.87	1.18	3/4	4.08	2.34	3.58	1.48	3.82	40
	3 1/2 in.															
TAFNL22K100S TAFNL22K315S TAFNL22K400S	100 mm	22222	360.8	309.9	145.0	218.4	219.1	270.0	30.0	20	112.5	62.7	99.6	42.2	105.0	27.2
	3 9/16 in.		14.21	12.20	5.71	8.60	8.63	10.63	1.18	3/4	4.43	2.47	3.92	1.66	4.13	60
	4 in.															

DVF AND DAAF SQUARE FLANGE BLOCKS

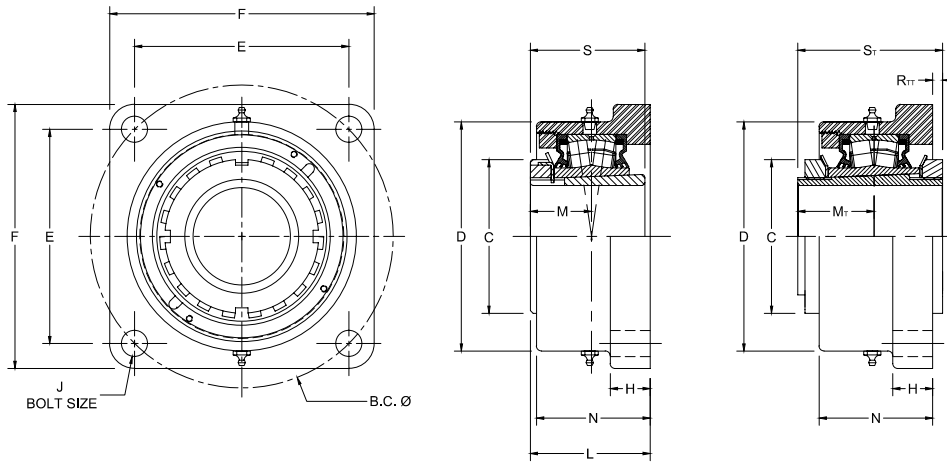

Bearing Part No.	Shaft Dia.	Bearing No.	B.C.	C	D	E	F	H	J	L FIX	L EXP	M	M _T	N	R _{TT}	S	S _T	Wt.
	mm in.		mm in.	mm in.	mm in.	mm in.	mm in.	mm in.	mm in.	mm in.	mm in.	mm in.	mm in.	mm in.	mm in.	mm in.	mm in.	kg lbs.
DVF09K107S DAAF09K107S	1 7/8 in.	22209	125.7 4.95	65.0 2.56	101.6 4.00	88.9 3.50	117.6 4.63	19.1 0.75	12	61.1 2.41	62.4 2.46	30.7 1.21	34.2 1.34	56.1 2.21	0.7 0.03	50.3 1.98	65.33 2.57	5.0 11
DVF09K108S DAAF09K108S	1 1/2 in.	22209	148.3	65.0	107.8	104.9	136.7	19.1	12	61.1	62.4	30.7	34.2	56.1	0.7	50.3	65.33	5.0
DVF09K040S DAAF09K040S	40 mm		5.84	2.56	4.25	4.13	5.38	0.75	1/2	2.41	2.46	1.21	1.34	2.21	0.03	1.98	2.57	11
DVF10K111S DAAF10K111S	1 11/16 in.	22210	148.3 5.84	70.1 2.76	118.4 4.66	104.9 4.13	136.7 5.38	22.4 0.88	12	59.0 2.32	60.3 2.37	33.5 1.32	37.6 1.48	52.3 2.06	8.2 0.32	55.1 2.17	71.33 2.81	5.5 12
DVF10K112S DAAF10K112S	1 3/4 in.	22210	157.2	70.1	118.4	111.3	143.0	22.4	12	59.0	60.3	33.5	37.6	52.3	8.2	55.1	71.33	5.5
DVF10K045S DAAF10K045S	45 mm		6.19	2.76	4.66	4.38	5.63	0.88	1/2	2.32	2.37	1.32	1.48	2.06	0.32	2.17	2.81	12
DVF11K115S DAAF11K115S	1 5/8 in.	22211	157.2	74.9	121.9	111.3	139.7	22.4	12	67.1	68.4	35.6	39.1	65.0	5.7	58.9	76.33	5.44
DVF11K200S DAAF11K200S	2 in.		6.19	2.95	4.80	4.38	5.50	0.88	1/2	2.64	2.69	1.40	1.54	2.56	0.23	2.32	3.01	12
DVF11K050S DAAF11K050S	50 mm																	
DVF13K203S DAAF13K203S	2 3/8 in.	22213	175.0	85.1	137.9	124.0	157.2	25.4	16	70.8	72.9	39.6	43.7	66.8	7.9	65.0	82.83	6.8
DVF13K204S DAAF13K204S	2 1/4 in.		6.89	3.35	5.43	4.88	6.19	1.00	5/8	2.79	2.87	1.56	1.72	2.63	0.31	2.56	3.26	15
DVF13K060S DAAF13K060S	60 mm																	
DVF15K207S DAAF15K207S	2 7/8 in.	22215	193.0	98.0	146.0	136.7	168.4	25.4	16	81.4	83.5	43.9	48.7	72.4	6.1	72.9	92.33	8.2
DVF15K208S DAAF15K208S	2 1/2 in.		7.60	3.86	5.75	5.38	6.63	1.00	5/8	3.20	3.29	1.73	1.92	2.85	0.24	2.87	3.64	18
DVF15K065S DAAF15K065S	65 mm																	

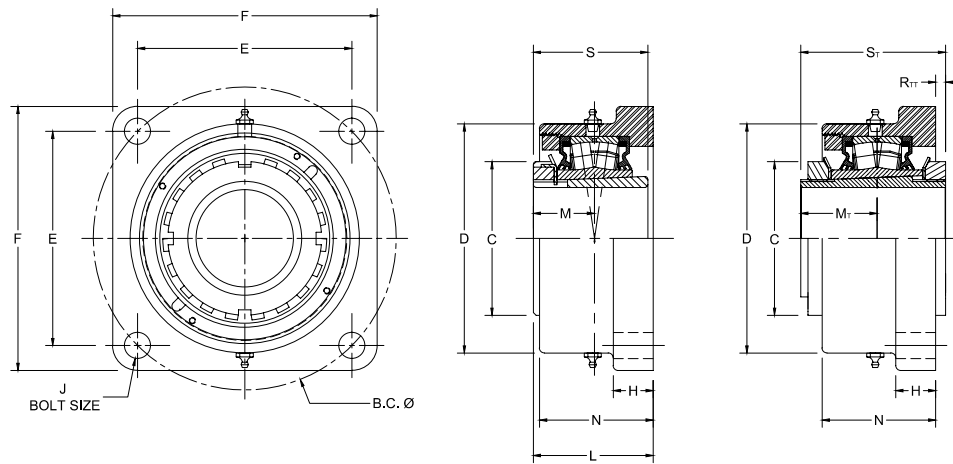

Bearing Part No.	Shaft Dia.	Bearing No.	B.C.	C	D	E	F	H	J	L FIX	L EXP	M	M _T	N	R _T	S	S _T	Wt.
	mm in.		mm in.	mm in.	mm in.	mm in.	mm in.	mm in.	mm in.	mm in.	mm in.	mm in.	mm in.	mm in.	mm in.	mm in.	mm in.	kg lbs.
DVF17K215S DAAF17K215S	2 1/8 in.	22217	215.4 8.48	110.0 4.33	170.7 6.72	152.4 6.00	189.0 7.44	26.9 1.06	20 3/4	87.9 3.46	90.0 3.54	49.8 1.96	50.2 1.98	77.0 3.03	16.0 0.63	82.0 3.23	104.33 4.12	12.7 28
DVF17K300S DAAF17K300S	3 in.																	
DVF17K075S DAAF17K075S	75 mm																	
DVF20K307S DAAF20K307S	3 7/8 in.	22220	251.5 9.90	130.0 5.12	193.8 7.63	177.8 7.00	219.2 8.63	33.3 1.31	20 3/4	100.9 3.97	103.0 4.06	58.4 2.30	63.6 2.51	84.1 3.31	15.7 0.62	97.0 3.82	121.83 4.80	17.7 39
DVF20K308S DAAF20K308S	3 1/2 in.																	
DVF20K090S DAAF20K090S	90 mm																	
DVF22K315S DAAF22K315S	3 15/16 in.	22222	278.4 10.96	145.0 5.71	215.9 8.50	196.9 7.75	253.2 9.97	38.1 1.50	24 7/8	119.9 4.72	122.0 4.80	63.0 2.48	65.8 2.59	103.1 4.06	8.0 0.31	104.9 4.13	130.7 5.15	24.0 53
DVF22K400S DAAF22K400S	4 in.																	
DVF22K100S DAAF22K100S	100 mm																	
DVF26K407S DAAF26K407S	4 7/8 in.	22226	314.5 12.38	165.1 6.50	263.7 10.38	222.3 8.75	276.4 10.88	38.1 1.50	24 7/8	124.7 4.91	126.8 4.99	71.9 2.83	76.6 3.01	106.9 4.21	20.3 0.80	120.9 4.76	149.65 5.89	34.0 75
DVF26K408S DAAF26K408S	4 1/2 in.																	
DVF26K115S DAAF26K115S	115 mm																	

TAFK AND TAAFK 9000 SERIES SQUARE FLANGE BLOCKS

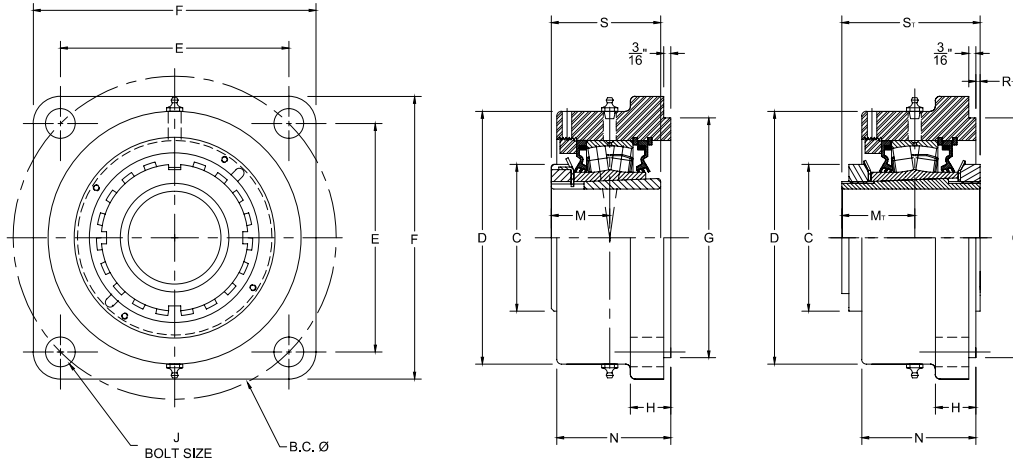

Bearing Part No.	Shaft Dia.	Bearing No.	B.C.	C	D	E	F	G ⁽¹⁾⁽²⁾⁽³⁾	H	J	L FIX	L EXP	M	M _T	N	R	R _T	S	S _T	Wt.
	mm in.		mm in.	mm in.	mm in.	mm in.	mm in.	mm in.	mm in.	mm in.	mm in.	mm in.	mm in.	mm in.	mm in.	mm in.	mm in.	mm in.	mm in.	kg lbs.
TAFK11K115S TAAFK11K115S	1 15/16 in.	22211	161.5	74.9	130.3	114.3	149.4	127.00	25.4	16	71.6	72.9	35.6	39.1	66.8	12.7	1.2	58.9	76.33	5.0
TAFK11K200S TAAFK11K200S	2 in.		6.36	2.95	5.13	4.50	5.88	5.000	1.00	5/8	2.82	2.87	1.40	1.54	2.63	0.50	0.05	2.32	3.01	11
TAFK11K050S TAAFK11K050S	50 mm	22213	180.8	85.1	146.1	127.8	157.2	138.13	25.4	16	77.7	79.8	39.6	43.7	72.4	12.7	1.0	65.0	82.83	6.
TAFK13K203S TAAFK13K203S	2 3/16 in.		7.12	3.35	5.75	5.03	6.19	5.438	1.00	5/8	3.06	3.14	1.56	1.72	2.85	0.50	0.04	2.56	3.26	14
TAFK13K204S TAAFK13K204S	2 1/4 in.	22215	215.9	98.0	168.9	152.7	189.0	160.35	26.9	20	84.8	86.9	43.9	48.7	76.2	11.9	2.7	72.9	92.33	7.7
TAFK13K060S TAAFK13K060S	60 mm		8.50	3.86	6.65	6.01	7.44	6.313	1.06	3/4	3.34	3.42	1.73	1.92	3.00	0.47	0.11	2.87	3.64	17
TAFK15K207S TAAFK15K207S	2 7/16 in.	22217	241.3	110.0	193.8	170.7	212.9	187.33	33.3	20	96.3	98.3	49.8	50.2	84.1	14.2	7.6	82.0	104.33	10.4
TAFK15K208S TAAFK15K208S	2 1/2 in.		9.50	4.33	7.63	6.72	8.38	7.375	1.31	3/4	3.79	3.87	1.96	1.98	3.31	0.56	0.30	3.23	4.12	23
TAFK15K065S TAAFK15K065S	65 mm	22220	298.5	130.0	215.9	211.1	268.2	225.43	38.1	24	114.6	116.6	58.4	63.6	103.1	17.5	2.0	97.0	121.83	15.9
TAFK17K215S TAAFK17K215S	2 15/16 in.		11.75	5.12	8.50	8.31	10.56	8.875	1.50	7/8	4.51	4.59	2.30	2.51	4.06	0.69	0.08	3.82	4.80	35
TAFK17K300S TAAFK17K300S	3 in.	22222	327.2	145.0	256.5	163.6	384.3	263.53	38.1	24	117.3	119.4	63.0	65.8	106.9	12.4	10.6	104.9	130.7	24.9
TAFK17K075S TAAFK17K075S	75 mm		12.88 ⁽⁴⁾	5.71	10.10	6.44 ⁽⁴⁾	15.13	10.375	1.50	1 ⁽⁴⁾	4.62	4.70	2.48	2.59	4.21	0.49	0.42	4.13	5.15	55
TAFK20K307S TAAFK20K307S	3 7/16 in.	22226	355.6	165.1	284.2	177.8	419.1	284.18	38.1	27	147.3	149.4	71.9	76.6	135.1	26.4	-2.4	120.9	149.65	49.0
TAFK20K308S TAAFK20K308S	3 1/2 in.		14.00 ⁽⁴⁾	6.50	11.19	7.00 ⁽⁴⁾	16.50	11.188	1.50	1 1/8 ⁽⁴⁾	5.80	5.88	2.83	3.01	5.32	1.04	-0.09	4.76	5.89	108
TAFK20K090S TAAFK20K090S	90 mm																			
TAFK22K315S ⁽⁴⁾ TAAFK22K315S ⁽⁴⁾	3 15/16 in.																			
TAFK22K400S ⁽⁴⁾ TAAFK22K400S ⁽⁴⁾	4 in.																			
TAFK22K100S ⁽⁴⁾ TAAFK22K100S ⁽⁴⁾	100 mm																			
TAFK26K407S ⁽⁴⁾ TAAFK26K407S ⁽⁴⁾	4 7/16 in.																			
TAFK26K408S ⁽⁴⁾ TAAFK26K408S ⁽⁴⁾	4 1/2 in.																			
TAFK26K115S ⁽⁴⁾ TAAFK26K115S ⁽⁴⁾	115 mm																			

⁽¹⁾Pilot tolerance: +0/-0.05 mm (+0/-0.002 in.).

⁽²⁾Add (p) to the end of the housing designation in the part number to order with pilot using G dimension.

⁽³⁾Piloted flange blocks will be quoted (price and delivery) upon request. For optional spigot on flange side, insert the letter P as seen in the following example: QMFP**J***S.

⁽⁴⁾Six-bolt housing.

TAMC AND TAAMC CARTRIDGE BLOCKS

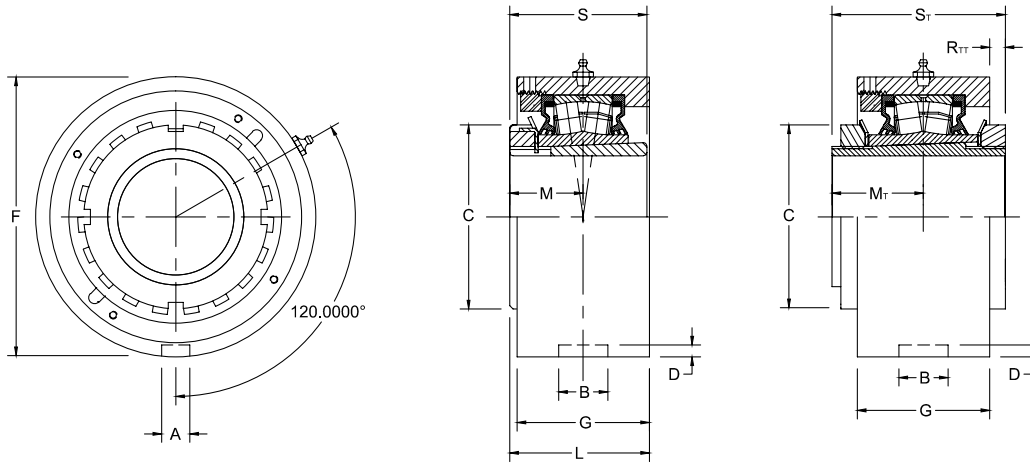

Bearing Part No.	Shaft Dia.	Bearing No.	A	B	C	D	F	G	L FIX	L EXP	M	M _T	R _{TT}	S	S _T	Wt.
	mm in.		mm in.	mm in.	mm in.	mm in.	mm in.	mm in.	mm in.	mm in.	mm in.	mm in.	mm in.	mm in.	mm in.	kg lbs.
TAMC11K115S TAAMC11K115S	1 1/8 in.	22211	13.5 0.530	23.0 0.906	74.9 2.95	4.8 0.188	115.09 (+0/-0.05) 4.531 (+0/-0.002)	55.4 2.18	63.2 2.49	64.5 2.54	35.6 1.40	39.1 1.54	9.6 0.38	58.9 2.32	76.33 3.01	4.5 10
TAMC11K200S TAAMC11K200S	2 in.															
TAMC11K050S TAAMC11K050S	50 mm	22213	13.5 0.530	23.0 0.906	85.1 3.35	4.8 0.188	127.00 (+0/-0.05) 5.000 (+0/-0.002)	67.1 2.64	70.9 2.79	72.9 2.87	39.6 1.56	43.7 1.72	7.8 0.31	65.0 2.56	82.83 3.26	5.4 12
TAMC13K203S TAAMC13K203S	2 3/8 in.															
TAMC13K204S TAAMC13K204S	2 1/4 in.	22215	15.1 0.594	26.2 1.032	98.0 3.86	6.4 0.250	149.23 (+0/-0.05) 5.875 (+0/-0.002)	70.6 2.78	78.2 3.08	80.3 3.16	43.9 1.73	48.7 1.92	9.3 0.37	72.9 2.87	92.33 3.64	8.2 18
TAMC13K060S TAAMC13K060S	60 mm															
TAMC15K207S TAAMC15K207S	2 7/8 in.	22217	15.1 0.594	27.5 1.083	110.0 4.33	7.1 0.281	171.45 (+0/-0.05) 6.750 (+0/-0.002)	74.9 2.95	87.4 3.44	89.4 3.52	49.8 1.96	50.2 1.98	16.5 0.65	82.0 3.23	104.33 4.12	11.8 26
TAMC15K208S TAAMC15K208S	2 1/2 in.															
TAMC15K065S TAAMC15K065S	65 mm	22220	19.8 0.781	32.5 1.281	130.0 5.12	8.0 0.313	206.38 (+0/-0.05) 8.125 (+0/-0.002)	85.6 3.37	101.3 3.99	103.4 4.07	58.4 2.30	63.6 2.51	15.3 0.60	97.0 3.82	121.83 4.80	14.5 32
TAMC20K307S TAAMC20K307S	3 7/8 in.															
TAMC20K308S TAAMC20K308S	3 1/2 in.	22222	19.8 0.781	32.5 1.281	145.0 5.71	8.0 0.313	222.25 (+0/-0.08) 8.750 (+0/-0.003)	97.8 3.85	112.0 4.41	114.0 4.49	63.0 2.48	65.8 2.59	15.9 0.63	104.9 4.13	130.7 5.15	18.1 40
TAMC20K090S TAAMC20K090S	90 mm															
TAMC22K315S TAAMC22K315S	3 1/8 in.	22226	19.8 0.780	38.1 1.500	165.1 6.50	8.0 0.313	265.10 (+0/-0.08) 10.437 (+0/-0.003)	104.4 4.11	124.2 4.89	126.2 4.97	71.9 2.83	76.6 3.01	20.8 0.82	120.9 4.76	149.65 5.89	23.6 52
TAMC22K400S TAAMC22K400S	4 in.															
TAMC22K100S TAAMC22K100S	100 mm	22226	19.8 0.780	38.1 1.500	165.1 6.50	8.0 0.313	265.10 (+0/-0.08) 10.437 (+0/-0.003)	104.4 4.11	124.2 4.89	126.2 4.97	71.9 2.83	76.6 3.01	20.8 0.82	120.9 4.76	149.65 5.89	23.6 52
TAMC26K407S TAAMC26K407S	4 7/8 in.															
TAMC26K408S TAAMC26K408S	4 1/2 in.	22226	19.8 0.780	38.1 1.500	165.1 6.50	8.0 0.313	265.10 (+0/-0.08) 10.437 (+0/-0.003)	104.4 4.11	124.2 4.89	126.2 4.97	71.9 2.83	76.6 3.01	20.8 0.82	120.9 4.76	149.65 5.89	23.6 52
TAMC26K115S TAAMC26K115S	115 mm															

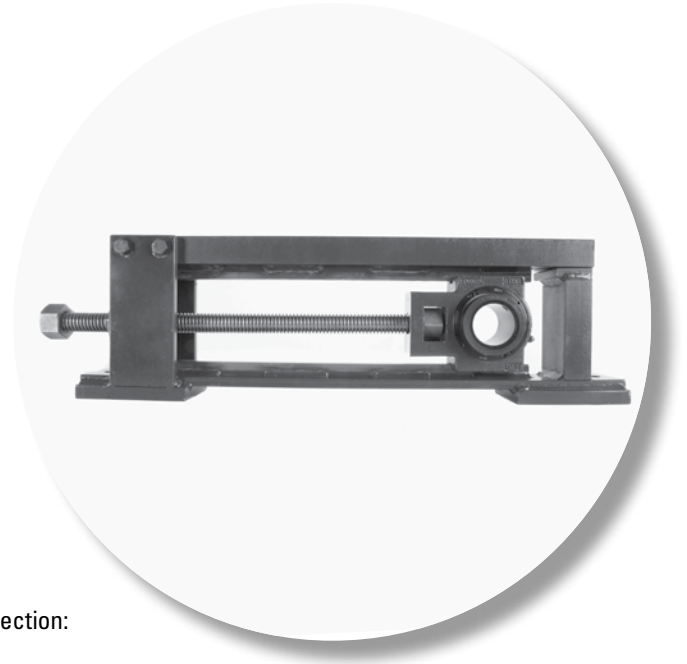

TAKE-UP FRAMES

The following topics are covered within this section:

QMTPF Center Pull Take-Up Frames	254
QMTF Take-Up Frames	255
QMT Pillow Block Take-Up Frames	256
QMTPF Top Angle Take-Up Frames	257
THD Heavy Duty Take-Up Frames	258

QMTPF CENTER PULL TAKE-UP FRAMES⁽¹⁾

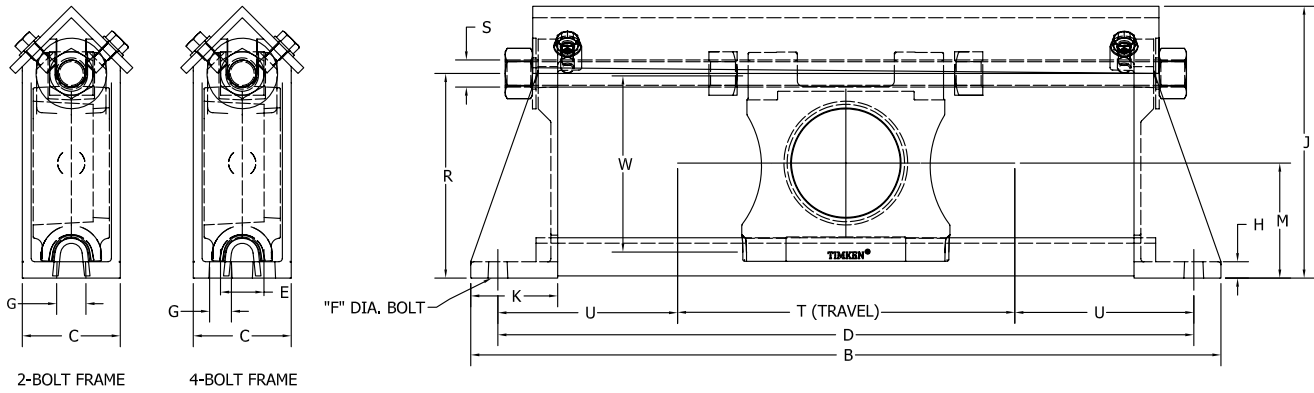

Frame Part No.	Travel Nom.	B	C	D	F	E	G	H	J	K	M	R	S	T	U	W	Wt.
		mm in.	mm in.	mm in.	mm in.	mm in.	mm in.	mm in.	mm in.	mm in.	mm in.	mm in.	mm in.	mm in.	mm in.	mm in.	mm in.
QMTPF12-115	12	723.9 28.50		673.1 26.50										368.3 14.50			14.52 32
QMTPF18-115	48	876.3 34.50	88.9 3.50	825.5 32.50	M16 %	-	25.4 1.00	19.0 0.75	215.9 8.50	76.2 3.00	100.0 3.94	161.1 6.34	¾-10 UNC	520.7 20.50	152.4 6.00	131.0 5.16	16.32 36
QMTPF24-115	24	1028.7 40.50		977.9 38.50										673.1 26.50			18.59 41
QMTPF12-203/207E	12	774.7 30.50		723.9 28.50										368.3 14.50			21.32 47
QMTPF18-203/207E	18	927.1 36.50	101.6 4.00	876.3 34.50	M20 ¾	-	33.3 1.31	19.1 0.75	257.2 10.13	88.9 3.50	111.1 4.38	187.3 7.38	1-8 UNC	520.7 20.50	177.8 7.00	157.2 6.19	24.49 54
QMTPF24-203/207E	24	1079.5 42.50		1028.7 40.50										673.1 26.50			27.21 60
QMTPF12-207/215	12	825.5 32.50		774.7 30.50										393.7 15.50			23.6 52
QMTPF18-207/215	18	977.9 38.50	114.3 4.50	927.1 36.50	M16 %	50.8 2	25.4 1.00	19.1 0.75	281 11.06	88.9 3.50	125.4 4.94	212.7 8.38	1-8 UNC	546.1 21.50	190.5 7.50	182.6 7.19	27.2 60
QMTPF24-207/215	24	1130.3 44.50		1079.5 42.50										698.5 27.50			29.9 66
QMTPF12-307	12	876.3 34.50		812.8 32.00										381 15.00			28.6 63
QMTPF18-307	18	1028.7 40.50	114.3 4.50	965.2 68.00	M20 ¾	50.8 2	25.4 1.00	19.1 0.75	317.5 12.50	101.6 4.00	138.1 5.44	239.0 9.41	1 ¼-7 UNC	533.4 21.00	215.9 8.50	208.8 8.22	31.7 70
QMTPF24-307	24	1181.1 46.50		1117.6 44.00										685.8 27.00			35.8 79
QMTPF12-315	12	977.9 38.50		914.4 36.00										419.1 16.50			38.1 84
QMTPF18-315	18	1130 44.50	139.7 5.50	1066.8 42.00	M20 ¾	63.5 2.5	25.4 1.00	19.1 0.75	362 14.25	114.3 4.50	177.8 7.00	288.0 11.34	1 ¼-7 UNC	571.5 22.50	244.5 9.63	226.2 8.91	41.7 92
QMTPF24-315	24	1282.7 50.50		1219.2 48.00										723.9 28.50			46.3 102

⁽¹⁾Frame only. Bearing unit must be ordered separately. See pages 176 (CL) and 206 (EC) for information on top pull take-up bearing units.

QMTF TAKE-UP FRAMES⁽¹⁾

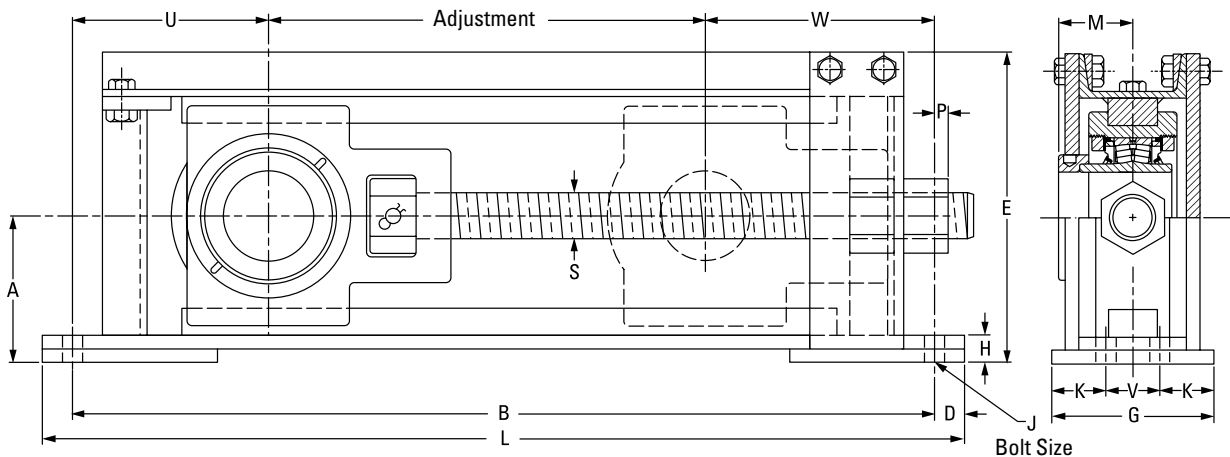

Frame Part No.	Travel Nom.	Travel Adj.	A	B	D	E	G	H	J	K	L	M	P	S	U	V	W	No. of Bolts Req.	Wt.
		mm in.	mm in.	mm in.	mm in.	mm in.	mm in.	mm in.	mm in.	mm in.	mm in.	mm in.	mm in.	mm in.	mm in.	mm in.	mm in.		kg lbs.
QMTF12-115	12	419.1 16.50	100.1 3.94	698.5 27.50	25.4 1.00	210.3 8.28	101.6 4.00	31.8 1.25	16 5/8	-	749.3 29.50	47.8 1.88	31.8 1.25	1-5 ACME	136.7 5.38	-	143.0 5.63	2	27.2 60
QMTF12-203	12	431.8 17.00	106.4 4.19	698.5 27.50	25.4 1.00	220.0 8.66	101.6 4.00	35.1 1.38	16 5/8	-	749.3 29.50	50.8 2.00	41.4 1.63	1.125-5 ACME	115.8 4.56	-	150.9 5.94	2	29.5 65
QMTF12-207	12	421.6 16.60	111.3 4.38	723.9 28.50	25.4 1.00	233.4 9.19	101.6 4.00	28.7 1.13	20 3/4	-	774.7 30.50	54.1 2.13	44.5 1.75	1.25-5 ACME	134.9 5.31	-	166.6 6.56	2	32.2 71
QMTF12-215	12	393.7 15.50	129.3 5.09	774.7 30.50	25.4 1.00	272.8 10.74	127.0 5.00	28.7 1.13	16 5/8	38.1 1.50	825.5 32.50	60.5 2.38	12.7 0.50	1.5-4 ACME	165.1 6.50	50.8 2.00	215.9 8.50	4	49.4 109
QMTF12-307	12	393.7 15.50	143.0 5.63	812.8 32.00	28.7 1.13	295.4 11.63	127.0 5.00	26.2 1.03	20 3/4	38.1 1.50	870.0 34.25	65.5 2.58	25.4 1.00	1.75-4 ACME	185.7 7.31	50.8 2.00	233.4 9.19	4	62.6 138
QMTF12-315	12	457.2 18.00	177.8 7.00	914.4 36.00	31.8 1.25	367.5 14.47	152.4 6.00	36.6 1.44	20 3/4	44.5 1.75	977.9 38.50	75.2 2.96	41.4 1.63	2-4 ACME	190.5 7.50	63.5 2.50	265.2 10.44	4	86.6 191
QMTF18-207	18	574.0 22.60	111.3 4.38	876.3 34.50	25.4 1.00	234.2 9.22	101.6 4.00	26.9 1.06	20 3/4	-	927.1 36.50	54.1 2.13	44.5 1.75	1.25-5 ACME	139.7 5.50	-	162.6 6.40	2	36.7 81
QMTF18-215	18	546.1 21.50	129.3 5.09	927.1 36.50	25.4 1.00	272.8 10.74	127.0 5.00	28.7 1.13	16 5/8	38.1 1.50	977.9 38.50	60.5 2.38	12.7 0.50	1.5-4 ACME	165.1 6.50	50.8 2.00	215.9 8.50	4	54.4 120
QMTF18-307	18	546.1 21.50	143.0 5.63	965.2 38.00	28.7 1.13	295.4 11.63	127.0 5.00	26.2 1.03	20 3/4	38.1 1.50	1022.4 40.25	65.5 2.58	25.4 1.00	1.75-4 ACME	185.7 7.31	50.8 2.00	233.4 9.19	4	70.8 156
QMTF18-315	18	609.6 24.00	177.8 7.00	1066.8 42.00	31.8 1.25	366.8 14.44	152.4 6.00	36.6 1.44	20 3/4	44.5 1.75	1130.3 44.50	75.2 2.96	41.4 1.63	2-4 ACME	190.5 7.50	63.5 2.50	265.2 10.44	4	101.2 223
QMTF24-207	24	726.4 28.60	111.3 4.38	1028.7 40.50	25.4 1.00	233.4 9.19	101.6 4.00	28.7 1.13	20 3/4	-	1079.5 42.50	54.1 2.13	44.5 1.75	1.25-5 ACME	115.8 4.56	-	166.6 6.56	2	41.3 91
QMTF24-215	24	698.5 27.50	129.3 5.09	1079.5 42.50	25.4 1.00	271.5 10.69	127.0 5.00	24.6 0.97	16 5/8	38.1 1.50	1130.3 44.50	60.5 2.38	12.7 0.50	1.5-4 ACME	165.1 6.50	50.8 2.00	215.9 8.50	4	64.0 141
QMTF24-307	24	698.5 27.50	143.0 5.63	1117.6 44.00	28.7 1.13	295.4 11.63	127.0 5.00	26.2 1.03	20 3/4	38.1 1.50	1174.8 46.25	65.5 2.58	25.4 1.00	1.75-4 ACME	185.7 7.31	50.8 2.00	233.4 9.19	4	81.2 179
QMTF24-315	24	762.0 30.00	177.8 7.00	1219.2 48.00	31.8 1.25	367.5 14.47	152.4 6.00	36.6 1.44	20 3/4	44.5 1.75	1282.7 50.50	75.2 2.96	41.4 1.63	2-4 ACME	190.5 7.50	63.5 2.50	265.2 10.44	4	112.9 249

⁽¹⁾Frame only. Bearing unit must be ordered separately. See pages 136 (V-Lock), 174-175 (CL) and 205 (EC) for information on take-up bearing units.
NOTE: Take-up frames come with NC threaded rod.

QMT PILLOW BLOCK TAKE-UP FRAMES⁽¹⁾

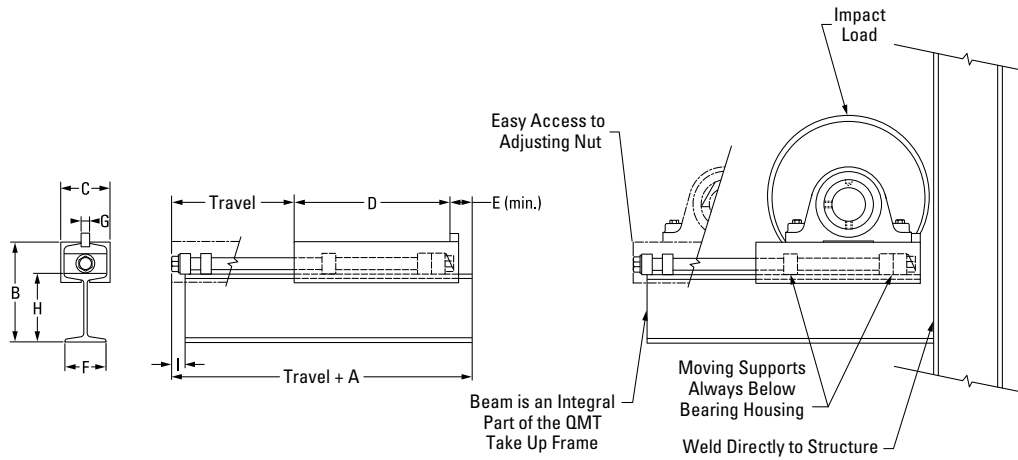

Frame Part No.	Bearing Size	Travel	A	B	C	D	E	F	G	H	I	Wt.
			mm in.	mm in.	mm in.	mm in.	mm in.	mm in.	mm in.	mm in.	mm in.	kg lbs.
QMT1 X 9	1 7/16 in. – 2 15/16 in.	9	330.2 13.0	187.3 7.375	92.1 3.625	289.1 11.38	41.4 1.63	76.2 3.00	20 3/4	127.0 5.0	25.4 1.0	11.8 26
QMT1 X 12	1 7/16 in. – 2 15/16 in.	12	330.2 13.0	187.3 7.375	92.1 3.625	289.1 11.38	41.4 1.63	76.2 3.00	20 3/4	127.0 5.0	25.4 1.0	13.6 30
QMT1 X 18	1 7/16 in. – 2 15/16 in.	18	330.2 13.0	187.3 7.375	92.1 3.625	289.1 11.38	41.4 1.63	76.2 3.00	20 3/4	127.0 5.0	25.4 1.0	16.3 36
QMT1 X 24	1 7/16 in. – 2 15/16 in.	24	330.2 13.0	187.3 7.375	92.1 3.625	289.1 11.38	41.4 1.63	76.2 3.00	20 3/4	127.0 5.0	25.4 1.0	19.1 42
QMT2 X 18	2 15/16 in. – 4 7/16 in.	18	482.6 19.0	311.2 12.25	125.4 4.938	431.8 17.00	50.8 2.00	106.4 4.19	24 1	203.2 8.0	38.1 1.5	33.6 74
QMT2 X 24	2 15/16 in. – 4 7/16 in.	24	482.6 19.0	311.2 12.25	125.4 4.938	431.8 17.00	50.8 2.00	106.4 4.19	24 1	203.2 8.0	38.1 1.5	40.8 90
QMT2 X 36	2 15/16 in. – 4 7/16 in.	36	482.6 19.0	311.2 12.25	125.4 4.938	431.8 17.00	50.8 2.00	106.4 4.19	24 1	203.2 8.0	38.1 1.5	43.6 96

⁽¹⁾Frame only. Bearing unit must be ordered separately.

QMTPF TOP ANGLE TAKE-UP FRAMES⁽¹⁾

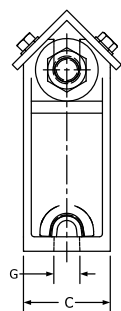

2-BOLT FRAME

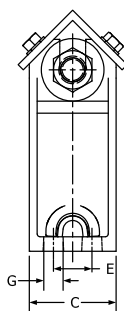

4-BOLT FRAME

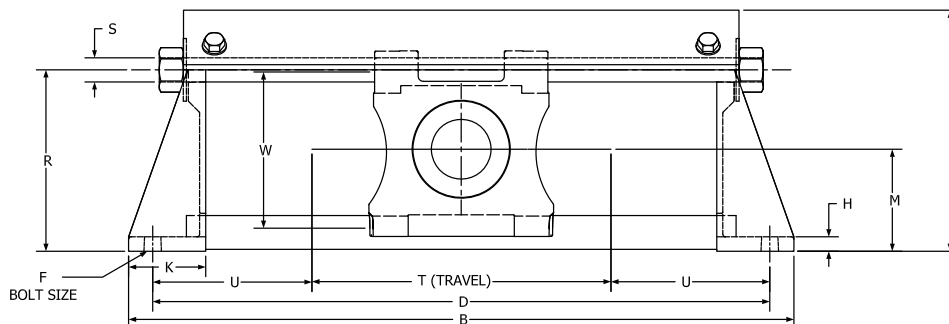

Bearing Part No.	Type E Shaft Size	SRB Shaft Size	Nominal "T"	B	C	D	F	E	G	H	J	K	M	R	S	T	U	W	Wt.	
				mm in.	mm in.	mm in.	mm in.	mm in.	mm in.	mm in.	mm in.	mm in.	mm in.	mm in.	mm in.	mm in.	mm in.	mm in.	mm in.	mm in.
QMTPF12-115	1 3/4 in.	1 1/8 in. 2 in.	304.8 12	723.9 28.50	88.9 3.50	673.1 26.50	M16 %	-	25.4 1.00	19.0 0.75	215.9 8.50	76.2 3.00	100.0 3.94	161.1 6.34	3/4-10 UNC	368.3 14.50	152.4 6.00	131.0 5.16	14.52 32	
QMTPF18-115	1 7/8 in.		457.2 48	876.3 34.50		825.5 32.50										520.7 20.50			16.32 36	
QMTPF24-115	2 in.		609.6 24	1028.7 40.50		977.9 38.50										673.1 26.50			18.59 41	
QMTPF12-203E	2 3/8 in. 50 mm	-	304.8 12	749.3 29.50	88.9 3.50	698.5 27.50	M16 %	-	25.4 1.00	19.1 0.75	231.8 9.13	76.2 3.00	106.4 4.19	177.0 6.97	3/4-10 UNC	381.0 15.00	158.8 6.25	146.8 5.78	15.52 34	
QMTPF18-203E			457.2 48	901.7 35.50		850.9 33.50										533.4 21.00			17.69 39	
QMTPF24-203E			609.6 24	1054.1 41.50		1003.3 39.50										685.8 27.00			19.5 43	
QMTPF12-203/207E	2 1/4 in.	2 3/8 in. 2 1/4 in.	304.8 12	774.7 30.50	101.6 4.00	723.9 28.50	M20 3/4	-	33.3 1.31	19.1 0.75	257.2 10.13	88.9 3.50	111.1 4.38	187.3 7.38	1-8 UNC	368.3 14.50	177.8 7.00	157.2 6.19	21.32 47	
QMTPF18-203/207E	2 7/8 in.		457.2 48	927.1 36.50		876.3 34.50										520.7 20.50			24.49 54	
QMTPF24-203/207E	2 1/2 in.		609.6 24	1079.5 42.50		1028.7 40.50										673.1 26.50			27.21 60	
QMTPF12-207/215	2 1/8 in.	2 7/8 in. 2 1/8 in.	304.8 12	825.5 32.50	114.3 4.50	774.7 30.50	M16 %	50.8 2	25.4 1.00	19.1 0.75	281.0 11.06	88.9 3.50	125.4 4.94	212.7 8.38	1-8 UNC	393.7 15.50	190.5 7.50	182.6 7.19	23.6 52	
QMTPF18-207/215	2 3/8 in.		457.2 48	977.9 38.50		927.1 36.50										546.1 21.50			27.2 60	
QMTPF24-207/215	2 1/2 in.		609.6 24	1130.3 44.50		1079.5 42.50										698.5 27.50			29.9 66	
QMTPF12-307	3 3/8 in.	3 3/8 in. 3 1/4 in.	304.8 12	876.3 34.50	114.3 4.50	812.8 32.00	M20 3/4	50.8 2	25.4 1.00	19.1 0.75	317.5 12.50	101.6 4.00	138.1 5.44	239.0 8.38	1 1/4-7 UNC	381.0 15.00	215.9 8.50	208.8 8.22	28.6 63	
QMTPF18-307	3 1/2 in.		457.2 48	1028.7 40.50		965.2 68.00										533.4 21.00			31.7 70	
QMTPF24-307	3 1/2 in.		609.6 24	1181.1 46.50		1117.6 44.00										685.8 27.00			35.8 79	
QMTPF12-315	3 1/8 in. 4 in.	3 1/8 in. 3 3/4 in.	304.8 12	977.9 38.50	139.7 5.50	914.4 36.00	M20 3/4	63.5 2.5	25.4 1.00	19.1 0.75	362.0 14.25	114.3 4.50	177.8 7.00	288.0 11.34	1 1/4-7 UNC	419.1 16.50	244.5 9.63	226.2 8.91	38.1 84	
QMTPF18-315			3 3/4 in.	457.2 48		1130.0 44.50										1066.8 42.00			571.5 22.50	41.7 92
QMTPF24-315			3 1/2 in.	609.6 24		1282.7 50.50										1219.2 48.00			723.9 28.50	46.3 102

⁽¹⁾Frame only. Bearing unit must be ordered separately. See pages 155-156 (CL) and 186 (EC) for information on take-up bearing units.

THD HEAVY DUTY TAKE-UP FRAMES

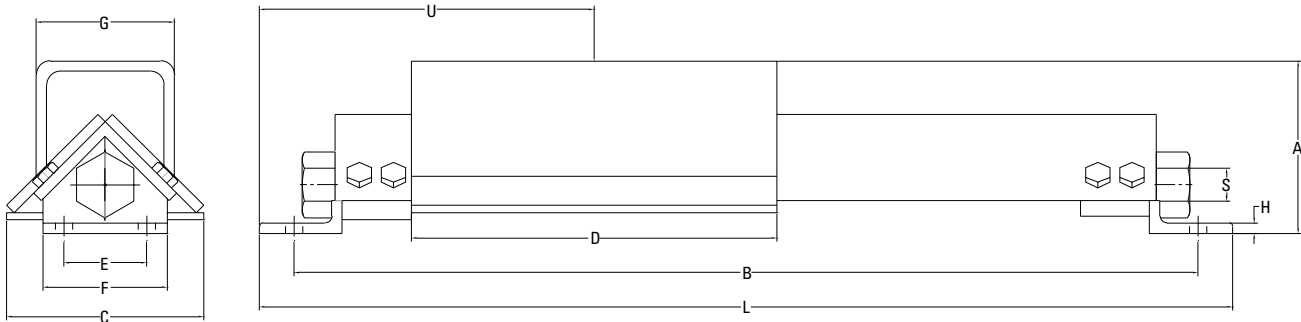

Frame Part No.	Travel Nom.	A	B	C	D	E	F	G	H	J	L	S	U	Wt.
		mm in.	mm in.	mm in.	mm in.	mm in.	mm in.	mm in.	mm in.	mm in.	mm in.		mm in.	kg lbs.
THD200X12	12		736.6 29.00								769.9 30.31			21.8 48.0
THD200X18	18	133.4 5.25	889.0 35.00	127.0 5.00	279.4 11.00	63.5 2.50	127.0 5.00	101.6 4.00	6.4 0.25	M16 %	896.9 35.31	1-5 ACME	247.7 9.75	23.6 52.0
THD200X24	24		1041.4 41.00								1074.7 42.31			25.4 56.0
THD200X36	36		1346.2 53.00								1379.5 54.31			29.0 64.0
THD208X12	12		831.9 32.75								895.4 35.25			37.6 83.0
THD208X18	18	158.8 6.25	984.3 38.75	139.7 5.50	336.6 13.25	76.2 3.00	139.7 5.50	127.0 5.00	9.5 0.38	M16 %	1073.2 41.25	1-5 ACME	276.2 10.88	40.4 89.0
THD208X24	24		1136.7 44.75								1200.2 47.25			43.0 95.0
THD208X36	36		1441.5 56.75								1505.0 59.25			48.5 107.0
THD300X12	12		901.7 35.50								971.6 38.25			62.1 137.0
THD300X18	18	177.8 7.00	1054.1 41.50	165.1 6.50	362.0 14.25	76.2 3.00	165.1 6.50	152.4 6.00	12.7 0.50	M20 ¾	1124.0 44.25	1.25-5 ACME	298.5 11.75	66.7 147.0
THD300X24	24		1206.5 47.50								1276.4 50.25			71.2 157.0
THD300X36	36		1511.3 59.50								1581.2 62.25			79.8 176.0
THD308X12	12		946.2 37.25								1016.0 40.00			66.7 147.0
THD308X18	18	177.8 7.00	1098.6 43.25	165.1 6.50	406.4 16.00	76.2 3.00	165.1 6.50	152.4 6.00	12.7 0.50	M20 ¾	1168.4 46.00	1.25-5 ACME	320.7 12.63	71.2 157.0
THD308X24	24		1251.0 49.25								1320.8 52.00			75.7 167.0
THD308X36	36		1555.8 61.25								1625.6 64.00			84.8 187.0
THD400X12	12		1047.8 41.25								1117.6 44.00			79.8 176.0
THD400X18	18	177.8 7.00	1200.2 47.25	165.1 6.50	508.0 20.00	76.2 3.00	165.1 6.50	177.8 7.00	12.7 0.50	M20 ¾	1270.0 50.00	1.25-5 ACME	396.9 15.63	84.4 186.0
THD400X24	24		1352.6 53.25								1422.4 56.00			88.9 196.0
THD400X36	36		1682.8 66.25								1727.2 68.00			98.0 216.0

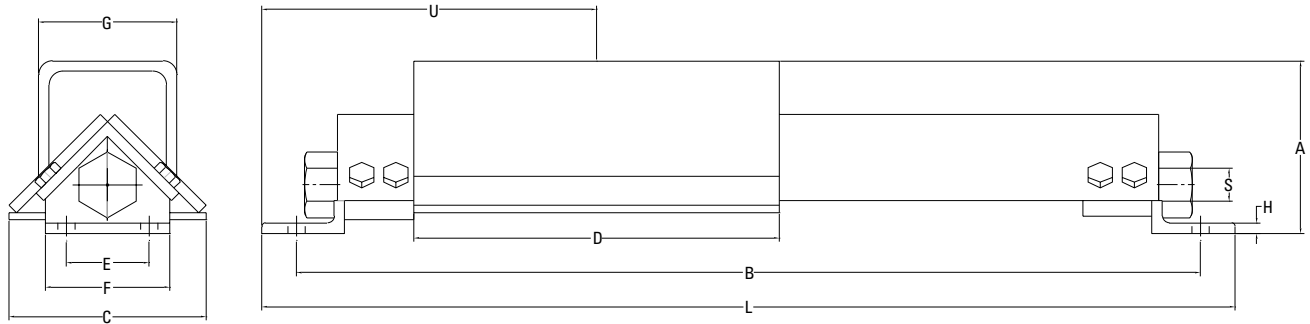

Frame Part No.	Travel Nom.	A	B	C	D	E	F	G	H	J	L	S	U	Wt.
		mm in.	mm in.	mm in.	mm in.	mm in.	mm in.	mm in.	mm in.	mm in.	mm in.		mm in.	kg lbs.
THD500X12	12	196.9 7.75	1193.8 47.00	177.8 7.00	596.9 23.50	101.6 4.00	177.8 7.00	215.9 8.50	12.7 0.50	M24 ¾	1257.3 49.50	1-5-4 ACME	419.1 16.50	137.9 304.0
THD500X18	18		1346.2 53.00								1409.7 55.50			146.6 321.0
THD500X24	24		1498.6 59.00								1562.1 61.50			152.9 337.0
THD500X36	36		1803.4 71.00								1866.9 73.50			168.3 371.0
THD600X12	12	260.4 10.25	1378.0 54.25	254.0 10.00	654.1 25.75	152.4 6.00	254.0 10.00	254.0 10.00	19.1 0.75	M24 1	1466.9 57.75	2-4 ACME	525.1 20.68	227.7 502.0
THD600X18	18		1530.4 60.25								1619.3 63.75			237.7 524.0
THD600X24	24		1682.8 66.25								1771.7 69.75			247.7 546.0
THD600X36	36		1987.6 78.25								2076.5 81.75			267.6 590.0
THD800X12	12	323.9 12.75	1546.2 60.88	304.8 12.00	914.4 36.00	152.4 6.00	304.8 12.00	304.8 12.00	19.1 0.75	M30 1¼	1800.2 70.88	2.5-3 ACME	539.8 21.25	362.4 799.0
THD800X18	18		1698.6 66.88								1952.6 76.88			372.9 822.0
THD800X24	24		1851.0 72.88								2105.0 82.88			382.8 844.0
THD800X36	36		2155.8 84.88								2409.8 94.88			403.2 889.0
THD1000X12	12	393.7 15.50	1689.1 66.50	355.6 14.00	1016.0 40.00	152.4 6.00	355.6 14.00	355.6 14.00	19.1 0.75	M38 1½	1934.1 76.50	3-2 ACME	590.6 23.25	540.7 1192.0
THD1000X18	18		1841.5 72.50								2095.5 82.50			559.3 1233.0
THD1000X24	24		1993.9 78.50								2247.9 88.50			577.9 1274.0
THD1000X36	36		2298.7 90.50								2552.7 100.50			615.5 1357.0

INDEX**SOLID-BLOCK MOUNTED SPHERICAL ROLLER BEARINGS**

Bearing Loads.....	34	QMCMD Piloted Flange Cartridges.....	193
CL Series (concentric [set screw] lock).....	137	QMCW Piloted Flange Cartridges.....	194
DVC and DAAC Piloted Flange Cartridges.....	241	QMF Four-Bolt Square Flange Blocks.....	196
DVF and DAAF Square Flange Blocks.....	248	QMFL Four-Bolt Square Flange Blocks.....	197
DVP and DAAP Two-Bolt Pillow Blocks.....	211	QMFMD Four-Bolt Square Flange Blocks.....	198
DVPF and DAAPF Four-Bolt Pillow Blocks.....	219	QMF5000 Series Square Flange Blocks.....	201
EC Series (eccentric lock).....	179	QMFY Round Flange Blocks.....	199
Engineering.....	9	QMMC Cartridge Blocks.....	203
Installation Guides.....	68	QMMH Hanger Blocks.....	207
Internal Radial Clearances.....	63	QMP Two-Bolt Pillow Blocks.....	181
Locking Styles.....	15	QMPF Four-Bolt Pillow Blocks.....	184
Lubrication.....	67	QMPH and QMPG Four-Bolt Pillow Blocks.....	186
Misalignment.....	67	QMPL Two-Bolt Pillow Blocks.....	182
Nomenclature.....	10	QMPMD Two-Bolt Pillow Blocks.....	183
Normal Speed Ratings for Seals.....	57	QMPR Four-Bolt Pillow Blocks.....	185
QAAFX 5000 Series Flange Blocks.....	169	QMPX 5000 Series Four-Bolt Pillow Blocks.....	187
QAAPX 5000 Series Four-Bolt Pillow Blocks.....	154	QMPXT 5000 Series Two-Bolt Pillow Blocks.....	189
QAAPXT 5000 Series Two-Bolt Pillow Blocks.....	149	QMSN SN-Style Two-Bolt Pillow Blocks – Pure Metric Design.....	190
QAC and QAAC Piloted Flange Cartridges.....	155	QMT Pillow Block Take-Up Frames.....	256
QACMD and QAACMD Piloted Flange Cartridges.....	157	QMTF Take-Up Frames.....	255
QACW and QAACW Piloted Flange Cartridges.....	159	QMTTP Top Angle Take-Up Blocks.....	206
QAF and QAAF Square Flange Blocks.....	161	QMTPF Center Pull Take-Up Frames.....	254
QAFE and QAAFE Square Flange Blocks.....	163	QMTPF Top Angle Take-Up Frames.....	257
QAFM and QAAFMD Square Flange Blocks.....	167	QMTU Take-Up Blocks.....	205
QAFY and QAAFY Round Flange Blocks.....	170	QVC and QVVC Piloted Flange Cartridges – Straight Bore Equivalent.....	130
QAMC and QAAMC Cartridge Blocks.....	172	QVCW and QVVCW Piloted Flange Cartridges – Straight Bore Equivalent.....	132
QAMH and QAAMH Hanger Blocks.....	178	QVF and QVVF Square Flange Blocks – Straight Bore Equivalent.....	115
QAP and QAAP Two-Bolt Pillow Blocks.....	139	QVFB and QVVFBSquare Flange Blocks – Tapered Adapter Equivalent.....	117
QAPF and QAAPF Four-Bolt Pillow Blocks.....	150	QVFC and QVFC Piloted Flange Cartridges – Tapered Adapter Equivalent.....	119
QAPL and QAAPL Two-Bolt Pillow Blocks.....	143	QVFK and QVFK 9000 Series Square Flange Blocks – Tapered Adapter Equivalent.....	125
QAPMD and QAAPMD Two-Bolt Pillow Blocks.....	145	QVFL and QVFL Square Flange Blocks – Straight Bore Equivalent.....	121
QAPR and QAAPR Four-Bolt Pillow Blocks.....	152		
QASN and QAASN SN-Style Two-Bolt Pillow Blocks – Pure Metric Design.....	147		
QATP and QAATP Top Angle Take-Up Blocks.....	176		
QATU and QAATU Take-Up Blocks.....	174		
QMC Piloted Flange Cartridges.....	192		

QVFNL Series Square Flange Blocks – Straight Bore Equivalent.	127	TA4DI and TAA4DI DI-Style Four-Bolt Pillow Block	224
QVFX and QVFX 5000 Series Square Flange Blocks – Straight Bore Equivalent.	123	TA4SD and TAA4SD Special Duty-Style Four-Bolt Pillow Block	222
QVFY and QVVFY Round Flange Blocks – Straight Bore Equivalent.	128	TAAPG SN-Style Four-Bolt Pillow Blocks	235
QVMC and QVVMC Cartridge Blocks – Tapered Adapter Equivalent.	134	TAAPH SAF 500-Style Four-Bolt Pillow Blocks	228
QVP and QVVP Two-Bolt Pillow Blocks – Straight Bore Equivalent.	92	TAAPH0 SAF 230-Style Four-Bolt Pillow Blocks	232
QVPA and QVPPA SAF Two-Bolt Pillow Blocks – Tapered Adapter Equivalent.	96	TAAPH0 SDAF 230-Style Four-Bolt Pillow Blocks	233
QVPF and QVVPF Four-Bolt Pillow Blocks – Straight Bore Equivalent.	103	TAAPH1 SDAF 231-Style Four-Bolt Pillow Blocks	234
QVPG and QVPPG SN-Style Four-Bolt Pillow Blocks – Tapered Adapter Equivalent.	109	TAAPH6 SAF 600-Style Four-Bolt Pillow Blocks	230
QVPH and QVPPH SAF-Style Four-Bolt Pillow Blocks – Tapered Adapter Equivalent.	111	TAAPH6D SDAF 600-Style Four Bolt Pillow Blocks	231
QVPK and QVPPK 9000 Series Four-Bolt Pillow Blocks – Tapered Adapter Equivalent.	113	TAAPHD SDAF 500-Style Four-Bolt Pillow Blocks	229
QVPKT and QVPPKT 9000 Series Two-Bolt Pillow Blocks – Tapered Adapter Equivalent.	102	TAASN 3000 Series Four-Bolt Pillow Block	237
QVPL and QVPPPL Two-Bolt Pillow Blocks – Straight Bore Equivalent.	94	TAASN 3100 Series Four-Bolt Pillow Block	239
QVPN and QVPPN SN-Style Two-Bolt Pillow Blocks – Tapered Adapter Equivalent.	98	TACK and TAACK Piloted Flange Cartridges	243
QVPR and QVPPR Four-Bolt Pillow Blocks – Straight Bore Equivalent.	105	TADI and TAADI DI-Style Two-Bolt Pillow Block	217
QVPX and QVPPX 5000 Series Four-Bolt Pillow Blocks – Straight Bore Equivalent.	106	TAFB and TAAFB Square Flange Blocks	246
QVPXT and QVPPXT 5000 Series Two-Bolt Pillow Blocks – Straight Bore Equivalent.	108	TAFC and TAAFC Square Piloted Flange Cartridges	245
QVSN and QVSSN SN-Style Two-Bolt Pillow Blocks – Pure Metric Design	100	TAFK and TAAFK 9000 Series Square Flange Blocks	250
QVVTU Take-Up Blocks – Straight Bore Equivalent.	136	TAFNL and TAAFNL Series Square Flange Blocks – Tapered Adapter Equivalent.	247
Seal and Cover Options.	16	Take-Up Frames	253
Solid-Block Mounted Spherical Roller Bearing Product Data Tables	89	TAMC and TAAMC Cartridge Blocks	251
TA/DV TAA/DAA Series (tapered adapter lock)	209	TAPA and TAAPA SAF-Style Two-Bolt Pillow Blocks	212
		TAPH and TAAPH SAF-Style Four-Bolt Pillow Blocks	226
		TAPK and TAAPK 9000 Series Four-Bolt Pillow Blocks	220
		TAPKT and TAAPKT 9000 Series Two-Bolt Pillow Blocks	218
		TAPN and TAAPN SN-Style Two-Bolt Pillow Blocks	214
		TASD and TAASD Special Duty-Style Two-Bolt Pillow Blocks	216
		THD Heavy Duty Take-Up Frames	258
		V-Lock® Series (taper lock)	89



To view more Timken catalogs, go to www.timken.com/catalogs for interactive versions, or to download the Timken catalog app for your smartphone or mobile device scan the QR code or go to timkencatalogs.squawqr.com.

TIMKEN

The Timken team applies their know-how to improve the reliability and performance of machinery in diverse markets worldwide. The company designs, makes and markets bearings, gear drives, automated lubrication systems, belts, brakes, clutches, chain, couplings, linear motion products and related industrial motion rebuild and repair services.

Stronger. By Design.

Price: USD \$75

www.timken.com