

TIMKEN



TIMKEN® FAFNIR® MOUNTED BALL BEARING CATALOG

ABOUT THE TIMKEN COMPANY

As a global leader in bearings and industrial motion systems, Timken focuses on precise solution design, materials and craftsmanship to deliver reliable and efficient performance that improves productivity and uptime. Timken offers a full range of bearings, gear drives, automated lubrication systems, belts, chains, couplings and linear motion products along with rebuild and repair services. Timken applies its proven expertise in metallurgy, tribology and industrial motion to create innovative approaches to customers' complex needs. Global availability of products and engineering talent, combined with exceptional service delivery across markets, makes Timken a preferred choice worldwide.

To view more Timken catalogs, go to www.timken.com/catalogs for interactive versions, or to download our catalog app to your smart phone or mobile device.

TIMKEN® FAFNIR® MOUNTED BALL BEARING CATALOG

INTRODUCTION	2
HOW TO USE THIS CATALOG	3
SHELF LIFE/STORAGE	3
WARNINGS	4
Engineering	5
Wide-Inner-Ring Ball Bearings	27
Mounted Ball Bearings	65



TIMKEN® FAFNIR® MOUNTED BALL BEARINGS OFFER EASY INSTALLATION, FLEXIBLE OPTIONS

Timken® Fafnir® mounted ball bearings, available in a variety of sizes and types, feature wide-inner-ring ball bearings that provide additional shaft support and locking options. The Timken® Fafnir® wide-inner-ring ball bearing is designed for straight shafts and can be positioned without shoulders, locknuts or adapters.

For easy installation, our mounted ball bearings can be ordered pre-assembled with bearings, housings, seals and locking systems. Choose from pillow blocks, flanged cartridges, take-up units and cylindrical cartridges. Our cast-iron, pressed-steel and

other optional materials give you durable choices for the exterior covers. Timken® Fafnir® locking options include set screws, self-locking collars and concentric collars.

Timken® Fafnir® Shaft Guarding Technology™ deters set-screw damage to shafts by placing a hardened band in the groove along the inner ring of the bearing. The set screws press against the band to transfer gripping pressure onto the shaft, preventing nicks, as well as raised-metal or permanent shaft damage. The stainless-steel band resists corrosion on the shaft. This system is particularly helpful for applications where it would be expensive and time-consuming to replace shafts.

TYPICAL INDUSTRIES AND APPLICATIONS

Use Timken Fafnir mounted ball bearings in agricultural applications, fans, blowers, food processing devices and conveyors.



HOW TO USE THIS CATALOG

We designed this catalog to help you find the Timken bearings best suited to your equipment needs and specifications. Timken offers an extensive range of bearings and accessories in both imperial and metric sizes. For your convenience, size ranges are indicated in millimeters and inches. Contact your Timken engineer to learn more about our complete line for the special needs of your application.

This publication contains dimensions, tolerances and load ratings, as well as engineering sections describing mounting and fitting practices for shafts and housings, internal clearances, materials and other bearing features.

It provides valuable assistance in the initial consideration of the type and characteristics of the bearings that may best suit your particular needs.

ISO, as used in this publication, refers to the International Organization for Standardization and JIS refers to the Japanese Industrial Standards.

Updates are made periodically to this catalog. Visit www.timken.com/catalogs for the most recent version of the Timken Fafnir Mounted Ball Bearing Catalog.

SHELF LIFE AND STORAGE OF GREASE-LUBRICATED BEARINGS AND COMPONENTS

To help you get the most value from our products, Timken provides guidelines for the shelf life of grease-lubricated ball and roller bearings, components and assemblies. Shelf life information is based on Timken and industry test data and experience.

SHELF LIFE

Shelf life should be distinguished from lubricated bearing/component design life as follows:

Shelf life of the grease-lubricated bearing/component represents the period of time prior to use or installation.

The shelf life is a portion of the anticipated aggregate design life. It is impossible to accurately predict design life due to variations in lubricant bleed rates, oil migration, operating conditions, installation conditions, temperature, humidity and extended storage.

TIMKEN IS NOT RESPONSIBLE FOR THE SHELF LIFE OF ANY BEARING/COMPONENT LUBRICATED BY ANOTHER PARTY.

European REACH compliance

Timken lubricants, greases and similar products sold in standalone containers or delivery systems are subject to the European REACH (Registration, Evaluation, Authorization and Restriction of CHemicals) directive. For import into the European Union, Timken can sell and provide only those lubricants and greases that are registered with ECHA (European CHemical Agency). For further information, please contact your Timken engineer.

STORAGE

Timken suggests the following storage guidelines for our finished products (bearings, components and assemblies, referred to as "products"):

- Unless directed otherwise by Timken, products should be kept in their original packaging until they are ready to be placed into service
- Do not remove or alter any labels or stencil markings on the packaging
- Products should be stored in such a way that the packaging is not pierced, crushed or otherwise damaged
- After a product is removed from its packaging, it should be placed into service as soon as possible
- When removing a product that is not individually packaged from a bulk pack container, the container should be resealed immediately after the product is removed
- The storage area temperature should be maintained between 0° C and 40° C; temperature fluctuations should be minimized
- The relative humidity should be maintained below 60 percent and the surfaces should be dry
- The storage area should be kept free from airborne contaminants such as, but not limited to, dust, dirt, harmful vapors, etc.
- The storage area should be isolated from undue vibration
- Extreme conditions of any kind should be avoided

Due to the fact that Timken is not familiar with your particular storage conditions, we strongly suggest following these guidelines. However, you may be required by circumstances or applicable government requirements to adhere to stricter storage requirements.

Be careful in selecting lubrication, however, since different lubricants are often incompatible.

When you receive a bearing shipment, do not remove products from their packaging until they are ready for mounting so they do not become corroded or contaminated.

Store bearings and bearing housings in an appropriate atmosphere so they remain protected for the intended period.

**WARNING**

Failure to observe the following warnings could create a risk of death or serious injury.

Proper maintenance and handling practices are critical. Always follow installation instructions and maintain proper lubrication.

Never spin a bearing with compressed air. The components may be forcefully expelled.

Overheated bearings can ignite explosive atmospheres. Special care must be taken to properly select, install, maintain and lubricate mounted bearings that are used in or near atmospheres that may contain explosive levels of combustible gases or accumulations of dust such as grain, coal, or other combustible materials.

Consult your equipment designer or supplier for installation and maintenance instructions.

If hammer and bar are used for installation or removal of a part, use a mild steel bar (e.g., 1010 or 1020 grade). Mild steel bars are less likely to cause release of high speed fragments from the hammer or bar or the part being installed or removed.

Ungrounded bearings can create static electricity that can ignite in an explosive atmosphere such as combustible gases or accumulations of dust such as grain, coal, or other combustible materials. Proper dissipation of such potential static electricity discharge must be assured to prevent any such explosion.

Below -40° C (-40° F), polymer housings may break. Select stainless or steel housings that operate to lower temperatures.

Tensile stresses can be very high in tightly fitted bearing components. Attempting to remove such components by cutting the inner ring may result in a sudden shattering of the component, causing fragments of metal to be forcefully expelled.

Always use properly guarded presses or bearing pullers to remove bearings from shafts, and always use suitable personal protective equipment, including safety glasses.

For additional Timken product warnings, visit www.timken.com/warnings.

CAUTION

Failure to observe the following cautions could result in property damage.

The products cataloged are application specific. Any use in applications other than those intended could lead to equipment failure or to reduced equipment life.

Use of improper bearing fits may cause damage to equipment.

Do not use damaged mounted bearings.

Do not use damaged bearings. The use of a damaged bearing can result in equipment damage.

NOTE

Do not use excessive force when mounting or dismounting the unit.

Follow all tolerance, fit, and torque recommendations.

Always follow the Original Equipment Manufacturer's installation and maintenance guidelines.

Ensure proper alignment.

Never weld mounted bearings.

Do not heat components with an open flame.

Do not operate at bearing temperatures above 121° C (250° F).

DISCLAIMER

This catalog is provided solely to give you analysis tools and data to assist you in your product selection. Product performance is affected by many factors beyond the control of Timken. Therefore, you must validate the suitability and feasibility of all product selections.

Timken products are sold subject to Timken terms and conditions of sale, which include our limited warranty and remedy. You can find these at <https://www.timken.com/legal-notices/termsandconditionsofsale/>.

Please consult with your Timken engineer for more information and assistance. Every reasonable effort has been made to ensure the accuracy of the information in this writing, but no liability is accepted for errors, omissions or for any other reason.

ENGINEERING

Antifriction bearings possess capabilities involving broad ranges of speed and many combinations of radial and thrust loads. Other important environmental conditions, such as low and high temperatures, dust and dirt, moisture and unusual conditions, affect bearing operation.

This engineering section is not intended to be comprehensive, but it does serve as a useful guide in bearing selection. Where more complex bearing applications are involved, contact your Timken engineer.

To view the complete engineering catalog, please visit www.timken.com. To order the catalog, please contact your Timken engineer and request a copy of the Timken Engineering Manual, order number 10424.

The following topics are covered within this section:

Materials	6
Internal Clearances	8
Cages	9
Lubrication	10
Load Ratings and Life Calculations	13
Frequency Coefficients	15
Mounting	16
Installation	24
Selection Guide for Applications	26



MATERIALS

TEMPERATURE RANGES, RESISTANCE TO CORROSION AND OTHER OPERATING ENVIRONMENTS

To accommodate the needs of the rapidly expanding industrial world, the capability of bearings in various extreme environments becomes vitally important. No general recommendations can be made to cover all such applications. Each installation must be studied to determine peak and average operating temperatures, length of time at these temperatures, load, oscillation or rotation, and any other factors affecting bearing operation.

RINGS, BALLS AND ROLLERS

Suggested materials for use in rings, balls and rollers at various operating temperatures together with data on chemical composition, hardness and dimensional stability are listed in table 1 on page 7. A temperature of 427° C (800° F) is generally the upper limit for successful bearing operating steels. Above 427° C (800° F), or below where lubricant is not permitted, cast or wrought-cobalt alloys are generally used. Although chosen primarily for their good retention of physical properties, they also possess good oxidation resistance at elevated temperatures.

CAGES, SHIELDS AND SEALS

Recommended materials for cages, shields and seals with their temperature capabilities are in table 3 on page 9.

DIMENSIONAL STABILITY

Dimensional stability of rings and balls is achieved by tempering the hardened steel until any further growth by transformation of austenite to martensite is balanced by shrinkage from tempering martensite. This balance is never perfect, and some size change will always occur. The amount depends upon the operating time and temperature of the bearings and the composition of and heat-treatment of the steel. The American Bearings Manufacturers Association (ABMA) definition for stabilized rings and balls permits a change of less than 0.0001 inch per inch after exposure to a temperature of 149° C (300° F) for 2500 hours. Rings and balls used at elevated temperatures are defined as stable by ABMA where there is a size change of less than 0.00015 inch per inch after 1500 hours of exposure at temperatures of 232° C, 316° C and 427° C (450° F, 600° F and 800° F).

CORROSION RESISTANCE

Timken developed a premium coating named TDC™ (thin-dense chrome), which has excellent corrosion resistance, as well as other properties leading to improved bearing life. TDC-coated bearings are intended for use in applications where unprotected bearings do not survive. This proprietary coating, emanating from years of research and testing, is a real problem-solver.

Besides its corrosion resistance feature, this coating has a high hardness (HRC 70-72), reduced coefficient of friction and a dense modular texture.

TDC is resistant to most organic and inorganic compounds. The normal thin coating of less than 0.003 mm (0.0001 in.) will outlast 440C stainless steel. The very high hardness, lower coefficient of friction and surface texture provide extra resistance to wear under less-than-ideal lubrication and thus longer bearing life.

Under normal lubrication conditions, TDC-coated races can provide fatigue life that's two times longer than the life of standard bearings.

To order wide-inner-ring ball bearings with TDC-coated races, stainless-steel balls and nylon retainers, specify suffix TDC or TDCF, which includes food safe grease (i.e., G1100KRRB + COL TDCF). This coating also can be readily applied to various types of tapered, cylindrical and spherical roller bearings.

To ensure proper application of TDC, contact your Timken engineer.

In addition to the bearings mentioned above, Timken is able to supply specially coated housing for applications involving particularly harsh environments where Food and Drug Administration (FDA) and United States Department of Agriculture (USDA) regulations apply. These housings, named Survivor® are available as electroless nickel-plated or polymer depending on the situation. The electroless nickel units are required for food processing, medical and other applications and may be ordered by adding an -NT suffix to the part number. The polymer units are similar to the NT units but offer superior protection against corrosion. Add the suffix -PT to the part when ordering.

Both coatings offer excellent protection to a broad variety of corrosive environments and are vulnerable only to a very few aggressive materials.

A complete review of operating conditions is essential before specifying corrosion-resistance mounted bearings and/or thin-dense chrome (TDC) coated bearings. Consult your Timken engineer for comprehensive recommendations.

OTHER CONSIDERATIONS

Installations that operate at high temperatures for extended periods may lose the quality of shaft and housing fits. Carefully machined and heat-treated shafts and housings will minimize trouble from this source.

In some applications, the internal clearance of bearings may be partially absorbed. For example, during the first few seconds of rotation, a massive housing may keep the outer race cooler than the inner race and balls, even if the housing is already at some elevated temperature. Also, during heat soakback, when rotation stops, heat may flow back to the bearing along the shaft. If, while stationary, the effects of heat soakback nullify

the radial internal clearance, radial brinelling of the races may occur and the bearing will be rough during subsequent rotation. Bearings with greater internal looseness may be required to compensate for these conditions. Consult your Timken engineer for recommendations.

This table provides standard operating temperatures for common bearing component materials. It should be used for reference purposes only. Other bearing component materials are available on request.

Contact your Timken engineer for further information.

TABLE 1. OPERATING TEMPERATURES FOR BEARING COMPONENT MATERIALS – RINGS, BALLS AND ROLLERS

Material	Approximate Chemical Analysis %	Temp. °C, (°F)	Hardness HRC	-73° C -100° F	-54° C -65° F	-17° C 0° F	38° C 100° F	93° C 200° F	121° C 250° F	149° C 300° F	204° C 400° F	260° C 500° F	316° C 600° F	371° C 700° F	427° C 800° F
Low-alloy carbon-chromium bearing steels. 52100 and others per ASTM A295	1C 0.5 – 1.5Cr 0.35Mn	21 (70)	60	STANDARD DIMENSIONAL STABILIZATION <0.0001 in./in dimensional change in 2500 hours at 100° C (212° F). Good oxidation resistance.											
Low-alloy carbon-chromium bearing steels. 52100 and others per ASTM A295	1C 0.5 – 1.5Cr 0.35Mn	21 (70) 177 (350) 232 (450)	58 56 54	Heat stabilized per FS136. When given a stabilizing heat treatment, A295 steel is suitable for many applications in the 177°–232° C (350°–450° F) range; however, it is not as stable dimensionally as it is at temperatures below 177° C (350° F). If utmost stability is required, use materials in the 316° C (600° F) group below.											
Deep-hardening steels for heavy sections per ASTM A485	1C 1 – 1.8Cr 1 – 1.5Mn .06Si	21 (70) 232 (450) 316 (600)	58 55 52	After heat-treated and tempered, it is stabilized.											
Carburizing steels per ASTM A534 a) low alloy 4118, 8X19, 5019, 8620 (Ni-Moly grades) b) high nickel 3310	Ni-Moly: 0.2C, 0.4-2.0Mn, 0.3-0.8Cr, 0-2.0Ni, 0-0.3Mo .01C, 1.5Cr, 0.4Mn, 3.5Ni	21 (70)	58	Nickel-Moly grades of steel frequently used to achieve extra ductility in inner rings for locking device bearings. 3311 and others used for extra-thick-section rings.											
Corrosion-resistant 440C stainless steel per ASTM A756	1C 18Cr	21 (70)	58	Excellent corrosion resistance.											
Corrosion-resistant 440C stainless steel per ASTM A756	1C 18Cr	21 (70) 232 (450) 316 (600)	58 55 52	Heat stabilized for maximum hardness at high temperatures (FS238). Good oxidation resistance at higher temperatures. Note load capacity drops off more rapidly at higher temperatures than M50 shown below, which should be considered if loads are high.											
M-50 medium high speed	4Cr 4Mo 1V 0.8C	21 (70) 232 (450) 316 (600)	60 59 57	Suggested where stable high hardness at elevated temperature is required.											

NOTE: Bearings have been made of special material for operation at temperatures above 427° C (800° F). Consult your Timken engineer regarding the application. ASTM A295 bearing steels are suitable for many applications up to 212° C (413° F) but are not as dimensionally stable as they are at the temperatures below 100° C (212° F).

INTERNAL CLEARANCE

RADIAL INTERNAL CLEARANCE

The radial internal clearance of radial contact ball bearings can be defined as the average outer ring raceway diameter minus the average inner ring raceway diameter minus twice the ball diameter.

RADIAL BALL BEARINGS

While manufacturing ball bearings, it is standard practice to assemble rings and balls with a specified internal clearance (table 2). This characteristic is necessary to absorb the effect of press fitting the bearing rings at mounting.

Internal clearance is sometimes utilized to compensate for thermal expansion of bearings, shafts and housings, or to provide a contact angle in the bearing after mounting.

Internal clearance can be measured by gaging either radially or axially.

Radial measurement is accepted as the more significant characteristic because it is more directly related to shaft and housing fits. It also is the method prescribed by the American Bearing Manufacturers Association (ABMA).

Radial internal clearance can be measured mechanically by moving the outer ring horizontally, as shown in fig. 1. The total movement of the outer ring when the balls are properly seated in the raceways determines the radial internal clearance. Several readings should be taken using different circumferential orientations of the rings to get a comprehensive average reading.

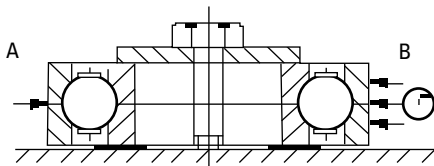

Fig. 1. Radial internal clearance. A and B are applied forces.

TABLE 2. LIMITS FOR RADIAL INTERNAL CLEARANCE OF SINGLE-ROW RADIAL CONTACT BALL BEARINGS UNDER NO LOAD (APPLIES TO BEARINGS OF ABEC1 AND ABEC3 TOLERANCES)

All tolerances in micrometers (µm) and ten-thousandths inches (0.0001 in.)

Timken Prefix (ABMA designation)		H (C2) Acceptance Limits		R (C0) Acceptance Limits ⁽¹⁾		P (C3) Acceptance Limits ⁽¹⁾		J (C4) Acceptance Limits		JJ (C5) Acceptance Limits	
Basic Bore Dia.											
Over	Incl.	Low	High	Low	High	Low	High	Low	High	Low	High
mm	mm	µm in.	µm in.	µm in.	µm in.	µm in.	µm in.	µm in.	µm in.	µm in.	µm in.
2.5	10	0	7	2	13	8	23	14	29	20	37
		0	3	1	5	3	9	6	11	8	15
10	18	0	9	3	18	11	25	18	33	25	45
		0	3.5	1	7	4	10	7	13	10	18
18	24	0	10	5	20	13	28	20	36	28	48
		0	4	2	8	5	11	8	14	11	19
24	30	1	11	5	20	13	28	23	41	30	53
		0.5	4.5	2	8	5	11	9	16	12	21
30	40	1	11	6	20	15	33	28	46	40	64
		0.5	4.5	2	8	6	13	11	18	16	25
40	50	1	11	6	23	18	36	30	51	45	73
		0.5	4.5	2.5	9	7	14	12	20	18	29
50	65	1	15	8	28	23	43	38	61	55	90
		0.5	6	3.5	11	9	17	15	24	22	35
65	80	1	15	10	30	25	51	46	71	65	105
		0.5	6	4	12	10	20	18	28	26	41
80	100	1	18	12	36	30	58	53	84	75	120
		0.5	7	4.5	14	12	23	21	33	30	47
100	120	2	20	15	41	36	66	61	97	90	140
		1	8	6	16	14	26	24	38	35	55
120	140	2	23	18	48	41	81	71	114	105	160
		1	9	7	19	16	32	28	45	41	63
140	160	2	23	18	53	46	91	81	130	120	180
		1	9	7	21	18	36	32	51	47	71
160	180	2	25	20	61	53	102	91	147	135	200
		1	10	8	24	21	40	36	58	53	79
180	200	2	30	25	71	63	117	107	163	150	230
		1	12	10	28	25	46	42	64	59	91
200	240	3	36	30	81	74	137	127	193	183	267
		1	14	12	32	29	54	50	76	72	105
240	280	3	41	33	97	86	157	147	224	213	310
		1	16	13	38	34	62	58	88	84	122
280	320	5	48	41	114	104	180	170	257	246	353
		2	19	16	45	41	71	67	101	97	139
320	370	5	53	46	127	117	208	198	295	284	409
		2	21	18	50	46	82	78	116	112	161
370	430	8	64	56	147	137	241	231	340	330	475
		3	25	22	58	54	95	91	134	130	187
430	500	10	74	66	170	160	279	269	396	386	551
		4	29	26	67	63	110	106	156	152	217
500	570	10	81	74	193	183	318	307	450	439	630
		4	32	29	76	72	125	121	177	173	248
570	640	13	91	85	216	206	356	345	505	495	706
		5	36	33	85	81	140	136	199	195	278
640	710	20	114	107	239	229	394	384	564	554	780
		8	45	42	94	90	155	151	222	218	307
710	800	20	140	130	269	259	445	434	630	620	879
		8	55	51	106	102	175	171	248	244	346
800	1060	28	211	201	353	345	587	577	833	823	1148
		11	83	79	139	136	231	227	328	324	452

⁽¹⁾Standard fits for Timken® radial ball bearings. P(C3) for bearing O.D. greater than 52 mm (greater than 25 mm bore).

CAGES

Cages (also referred to as rolling-element retainers) serve several purposes in the proper operation of a rolling-element bearing. Cages separate the rolling elements and prevent rolling-element-on-rolling-element contact and wear. Cages serve to maintain rolling-element spacing in the races of the inner and outer rings of the bearings as the rolling elements pass into and out of the load zones. For handling purposes, cages also can retain the rolling elements on the inner ring assembly to allow for bearing installation.

To meet the needs of the various service requirements of customers, Timken offers two reliable cage types for wide-inner-ring ball bearings – pressed-steel welded cages and molded-nylon finger-type cages.

PRESSED-STEEL WELDED CAGES

This cage type consists of two formed cage halves welded together (fig. 2). This type of cage is standard for most radial non-filling-slot ball bearings, providing high strength and rigidity, as well as good uniformity of ball-to-pocket clearance. It is suitable for very high-temperature applications, but does not accommodate application misalignment.



Fig. 2. Pressed-steel welded cage.

MOLDED-NYLON FINGER-TYPE CAGES

This type of cage consists of a one-piece molded design (fig. 3). Rolling elements simply snap into place. Used in the majority of wide-inner-ring ball bearings, these cages are molded of nylon 6/6 that is heat-stabilized and moisture-conditioned. The polymer can withstand continuous operating temperatures up to 120° C (250° F) with spikes up to 150° C (300° F) and provides a non-corrosive, self-lubricating material with good resistance to abrasion, wear, most solvents, oils and greases. This cage type can accommodate application misalignment.

Care needs to be exercised when using aggressive lubricants with extreme-pressure (EP) additives in combination with elevated temperatures greater than 107° C (225° F).



Fig. 3. Molded-nylon cage.

TABLE 3. OPERATING TEMPERATURES FOR BEARING COMPONENT MATERIALS—CAGES, SHIELDS AND SEALS

	-54° C -65° F	-17° C 0° F	38° C 100° F	93° C 200° F	149° C 300° F	204° C 400° F	260° C 500° F	316° C 600° F	371° C 700° F	427° C 800° F
CAGES										
Molded 6/6 nylon (PRB)										
Molded 6/6 fiberglass reinforced nylon (PRC)										
Phenolic resin laminate										
Low-carbon pressed steel										
Pressed stainless steel										
Machined bronze										
Machined iron-silicon bronze										
Machined steel										
SHIELDS										
Low-carbon steel										
Stainless steel										
Nylon										
SEALS										
Buna N										
Polyacrylic										
Fluoroelastomer										
Stabilized TFE fluorocarbon ⁽¹⁾										
TFE fluorocarbon ⁽¹⁾ (with glass fabric)										

⁽¹⁾Limited life above these temperatures.

LUBRICATION SPEED CAPABILITY

There is no precise method for determining the maximum speed at which a ball bearing may operate. Bearing characteristics and features of surrounding parts, shafts, housings and other components, as well as basic service conditions, are all variables that are dependent upon each other for continued satisfactory high-speed performance.

The safe operating speed of a ball bearing is often limited by the temperature within the bearing, which, in turn, is dependent upon the temperature surrounding the application, bearing seals, shaft and housing tolerances, auxiliary parts, etc., and the type and amount of lubricant.

Although the speed values shown in the table 4 are based on many years of research and accumulated data, numerous bearing applications successfully operate with speed ratings in excess of those tabulated. Such applications should be reviewed by your Timken engineer.

The values in the following table may be used as a general guide for determining the safe maximum speed of standard types of wide-inner-ring ball bearings. To obtain the speed rating for any bearing size with inner ring rotation, multiply the bore in millimeters of the basic size bearing by the speed in revolutions per minute.

TABLE 4. MAXIMUM OPERATING SPEED RECOMMENDATIONS

Timken Fafnir Series	Maximum dN Values
Industrial Duty	
R series	175000
Y series	175000
Medium Y series	175000
Special Duty	
R-NT series	175000
SAL and SAOL series	275000
RAKH and RAKHL series	175000
Severe Duty	
R-PT series	175000
Y-PT series	175000
L series	250000
T series	500 RPM maximum ⁽¹⁾
Standard Duty	
V series	140000
S series	140000

⁽¹⁾Please contact your Timken engineer for applications where speeds may exceed 500 RPM.

Example:

Find the maximum operating speed for an LAK1 pillow block.

1. Find the maximum dN value for an LAK1 from the above table.
250000
2. Find the bore of an LAK1 in millimeter.
1 in. = 25.4 mm
3. Apply the dN equation.

$$\begin{aligned} dN \text{ max.} &= \text{bearing bore (in.mm)} \times \text{max. operating speed} \\ 250000 &= 25.4 \times \text{maximum operating speed} \\ \text{Max. operating speed} &= 250000/25.4 = 9840 \text{ RPM} \end{aligned}$$

Thus, the maximum operating speed for an LAK1 is 9840 RPM.

LUBRICANT SELECTION

The successful application of lubricating fluids on bearings depends on the physical and chemical properties of the lubricant as they pertain to the bearing, its application, installation and general environmental factors.

VISCOSITY

Generally, the most important single property of a lubricating fluid is its viscosity. Viscosity is the measure of the relative resistance of a fluid to flow and is a function of speed and temperature (fig. 4).

The measurement of viscosity can be made by several different instruments called viscosimeters. A common unit of measure is the Saybolt Universal Second (SUS). This is the time, in seconds, required for 60 cc of a fluid to flow through a standardized orifice under a standard head, at a given temperature. The common temperatures for reporting viscosity are 37.78° C to 98.89° C (100° F to 210° F). The higher the viscosity number, the greater the resistance to flow.

Experience indicates that a lubricating fluid with a viscosity of at least 100 SUS at the operating temperature of the application will be adequate for normal bearing lubrication.

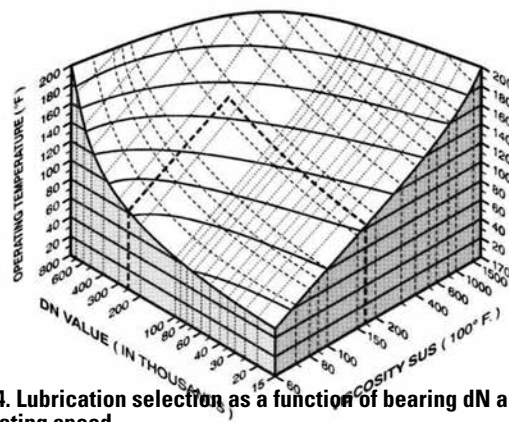

Fig. 4. Lubrication selection as a function of bearing dN and operating speed.

VISCOSITY INDEX

The ideal oil (as far as viscosity is concerned) would be the same viscosity at all temperatures. All oils become less viscous (thin-out) when heated and more viscous (thickened) when cooled.

However, oils do not vary in viscosity to the same extent. Some thicken or thin more rapidly than others.

The term viscosity index, or VI, is used to rate oils according to their temperature-viscosity behavior.

Oils with the highest viscosity index are more resistant to changes in viscosity with changes in temperature than lower viscosity index oils. Obviously, high viscosity-index lubricants are most suitable for bearing applications experiencing wide temperature variations.

The National Lubricating Grease Institute (NLGI) classification of grease consistency is shown below (table 5):

TABLE 5. NLGI CLASSIFICATIONS

NLGI Grease Grades	Penetration No.
0	355-385
1	310-340
2	265-295
3	220-250
4	175-205
5	130-160
6	85-115

POUR POINT

The pour point is the lowest temperature at which a fluid will flow or can be poured. It is important in applications exposed to low temperatures that the lubricating fluid selected has a pour point lower than the minimum ambient temperature.



WARNING

Failure to observe the following warnings could create a risk of death or serious injury.

Proper maintenance and handling practices are critical.
Always follow installation instructions and maintain proper lubrication.

TYPES OF LUBRICATION

Timken understands the importance of friction management. Our line of application- and environment-specific lubricants has been developed by leveraging our knowledge of tribology and antifriction bearings, as well as how these two elements affect overall system performance.

Timken® lubricants help bearings and related components operate effectively in demanding industrial operations. High-temperature, anti-wear and water-resistant additives offer superior protection in challenging environments.

Similar to our bearings, all Timken lubricants are backed by highly trained customer service and technical support associates. Industrial customers turn to Timken for comprehensive friction management solutions. We help customers analyze performance and suggest options that make sense for their unique operating conditions and maintenance intervals.

TABLE 6. STANDARD BALL-BEARING LUBRICATION

Bearing Type	Grease Type	Grease Temperature Range
Radial bearings (double shielded, and single and double shielded)	Polyurea thickener Petroleum oil	-34.44° C to +135° C (-40° to +275° F)
Wide-inner-ring ball bearings (contact seal types)	Polyurea thickener Petroleum oil	-34.44° C to +135° C (-40° to +275° F)
Wide-inner-ring ball bearings (labyrinth seal types)	Synthetic thickener Synthetic hydrocarbon fluid	-53.89° F to +162.75° C (-65° F to +350° F)

NOTE: Open-type bearings and single-shielded types are not prelubricated. They have a rust-preventative coating only and must be lubricated by the customer or end-user before operation.

Bearings that have been factory pre-lubricated use a high-quality grease. Bearings with contacting lip seals and shields contain No. 2 polyurea base grease. Bearings with non-contacting labyrinth seals (suffix KLL in bearing part number) contain a No. 2 modified clay base grease. For normal conditions of service, these bearings require no further lubrication.

Normal service is considered as operating in a clean, dry environment at temperatures between -34° C to +82° C (-30° F to +180° F) and at dN values (bore in millimeter multiplied by speed in RPM) less than 175000.

If service is considered abnormal due to speed, temperature or exposure to moisture, dirt or corrosive chemicals, periodic relubrication may be advisable. Excessive relubrication may cause high operating temperatures due to grease churning. General guidelines for relubrication are provided in table 7.

TIMKEN BALL-BEARING PILLOW-BLOCK GREASE

Timken ball-bearing pillow-block grease is an NLGI No. 2 polyurea-thickened grease. It provides outstanding long life and moderately high-temperature lubrication to ball bearings. This grease maintains its mechanical shear stability and provides corrosion resistance, even in the presence of salt water. Timken ball-bearing pillow-block grease features low-noise characteristics and excellent pumpability. This grease does not contain extreme-pressure additives but inhibits rust and oxidation. Operating temperatures range from -40° C to 163° C (-40° F to 400° F). This grease is typically used in lightly loaded ball bearings in pillow blocks and conveyors that operate in high-temperature environments, including kiln and glasswork applications, electric motors, chemical manufacturing and noise-sensitive environments.

SAL/SAOL LUBRICATION

SAL/SAOL mounted bearings are intended for use with oil lubrication and are equipped with a filler cup located on top of the pillow block. Each housing assembly also has an overflow cup and a pipe plug located at the base. These can be interchanged as required to properly locate the overflow cup with respect to shaft rotation. The overflow cup should be placed on the downward side of the shaft rotation. Incorrect placement will cause oil to leak from the overflow cup during operation. Oil should be supplied through the filler cup until overflow is full. Please note to inspect and refill only when the shaft is stationary to avoid overfilling.

Inspection is necessary to determine the frequency of refilling, which is based on a number of factors, including speed, temperature and oil type. To avoid inadequate lubrication, maintain the oil level to the top of the overflow cup.

In general, a high-quality automotive or turbine oil with oxidation inhibitors is recommended. For normal operating conditions, an SAE 30 weight oil or equivalent is adequate. Contact your Timken engineer for abnormal service lubrication recommendations.

SURVIVOR® PT, NT AND PS LUBRICATION

These mounted bearings are specifically designed for use in conditions of corrosion and contamination. The premium bearing insert is factory-prelubricated with aluminum-complex, high-quality, type H1, food-grade grease. This grease is acceptable in applications with incidental food contact.

GENERAL RELUBRICATION SUGGESTIONS

Periodic relubrication is advisable due to the nature of food-grade grease and the corrosive environments for which these units are designed. Consult your equipment manufacturer’s operating manual for the relubrication cycle. General guidelines are found in table 7.

TABLE 7. GENERAL RELUBRICATION RECOMMENDATIONS FOR GREASED BEARINGS⁽¹⁾

Condition	Relubrication Interval
Indoor service	Not required
Outdoor service	Two/three times per year
Severe outdoor exposure	Once a month
High contamination/washdown	Once a week

⁽¹⁾As a guideline, relubricate until the first indication of grease is observed purging from either seal lip.

SINGLE-POINT AND CENTRALIZED MULTI-POINT LUBRICATORS

Proper lubrication is critical to bearing and machine performance. To help prevent damage, Timken G-Power and M-Power single-point lubricators deliver periodic grease to bearings, chains, guideways and other industrial equipment components (fig. 5). You can choose from gas-powered or electromechanical varieties to meet your operating specifications. C-Power multi-point lubricators are a centralized lubrication system capable of delivering grease to up to six lubrication points (fig. 6). Oil is not an option for this unit.

G-Power, M-Power and C-Power canisters can be filled with Timken-formulated lubricants or many other types of commercial lubricants. A full line of accessories— including brackets, clamps, brushes, fittings and hose extensions— ease installation and offer a host of mounting options for hard-to-reach locations.



Fig. 5. G-Power and M-Power lubrication units with activators.



Fig. 6. C-Power.

LOAD RATINGS AND LIFE CALCULATIONS

RADIAL BALL-BEARING LOAD RATINGS

The load ratings published in this catalog are based on ABMA Standard Section 9, but they are increased to reflect improvements in materials and processing. These ratings are referred to as extended basic dynamic load ratings (C_E). Care must be taken that the extended basic dynamic load ratings only be used in equations containing C_E .

NOTATIONS USED IN THIS SECTION

- C_N = Radial load rating of bearings at operating speed N – pounds or newtons = ($N_f \times C_E$)
- C_E = Extended basic dynamic load rating – radial ball bearings pounds or newtons
- C_o = Basic static load rating – radial ball bearing pounds or newtons⁽¹⁾
- K_T = Relative thrust-load factor – ball bearings
- L_f = Life factor
- L_r = Fatigue life for reliability level r – hours
- N = Operating speed – revolutions per minute (RPM)
- N_f = Speed factor
- R = Applied radial load on bearing pounds or newtons
- P = Equivalent radial load on bearing pounds or newtons
- T = Applied thrust load on bearing pounds or newtons
- Y = Thrust-load factor
- a_1 = Life-adjustment factor for reliability⁽²⁾
- a_2 = Life-adjustment factor for bearing material⁽³⁾
- a_3 = Life-adjustment factor for application conditions⁽⁴⁾
- f_B = Dynamic load rating adjustment factor for number of adjacently mounted bearings⁽⁵⁾
- i_B = Number of adjacently mounted bearings
- r = Percent reliability of survival life
- μ = Operating viscosity – centistokes
- μ_R = Reference viscosity – centistokes

⁽¹⁾ C_E does **not** represent the maximum permissible radial load, which, in general, is equal to C_o , the static radial load ratings.

⁽²⁾ L_{10} rating life is based upon 90 percent survival of a group of bearings at the specified load and speed. The a_1 value is 1.0 for L_{10} life calculations.

⁽³⁾The a_2 value is 1.0 when using typical Timken® bearing steel. Bearings with thin-dense chrome-plated races may use an a_2 factor of 3.0 for calculating life.

⁽⁴⁾The a_3 factor of 1.0 may be acceptable to most users, but the factor can be made up of multiple application factors such as adequate lubrication, alignment, temperature or mounting conditions. ABMA standard suggests and a_3 of 0.456 for insert ball bearings slip fitted to the shaft as a result of possible mounting variation.

⁽⁵⁾ $f_B = 1.0$ for wide-inner-ring ball bearings.

FATIGUE LIFE

Because of the dispersion in the life of identical bearings operating under identical conditions, a statistical result will be obtained for bearing fatigue life. For most calculations, life is expressed as the number of hours that 90 percent of a group of identical bearings will exceed under a given set of conditions, and is referred to as the L_{10} life.

The basic equation for radial ball bearings is:

$$L_r = 16667 \times \frac{a_1 \times a_2 \times a_3}{N} \frac{[f_B \times C_E]^3}{P} \text{ (Hours)} \quad \text{Formula 1}$$

In life calculations, the first step is to ascertain the equivalent radial load (P) applied to the bearing from the following equations:

$$R_e = R \text{ or } P = 0.56R + YT \quad \text{use greater value of P, Formula 2 3}$$

Values of Y are selected from table 8 for the appropriate K_T . For more intermediate values of K_T , Y may be estimated by linear interpolation.

TABLE 8. REQUIRED Y FACTORS FOR BALL BEARING DYNAMIC EQUIVALENT RADIAL LOADS

K_T	Y
0.015	2.30
0.020	2.22
0.025	2.10
0.030	2.00
0.040	1.86
0.050	1.76
0.060	1.68
0.080	1.57
0.100	1.48
0.120	1.42
0.150	1.34
0.200	1.25
0.250	1.18
0.300	1.13
0.400	1.05
0.500	1.00
0.600	–
0.800	–
1.000	–
1.200	–

For single-row bearings and tandem mountings: $K_T = \frac{T}{i_B C_o}$

For double-row and preloaded pair mountings: $K_T = \frac{T}{C_o}$

RADIAL BALL BEARING LIFE

The L_{10} (expected minimum life for 90 percent of the bearings of a given size and type in a given population) is calculated by the following formula, which is a condensed version of formula 1.

$$L_{10} = \frac{16700}{N} \left(\frac{C_E}{P} \right)^3 \quad \text{(Hours)} \quad \text{Formula 4}$$

The calculation of bearing life also can be performed by using logarithmic factors for rotational speed (N_f) and life (L_f) based on the formula.

$$L_{10} = 500 \left(\frac{C_N}{P} \right)^3 \quad \text{(Hours)} \quad \text{Formula 5}$$

In cases where the rating at a specific speed is not listed, determine C_N by $C_N = N_f \times C_E$; thereby:

$$L_{10} = 500 \left(\frac{N_f C_E}{P} \right)^3 \quad \text{Formula 6}$$

where:

$$N_f = \left(\frac{1}{0.03N} \right)^{3/10} \quad \text{Formula 7}$$

The speed factor (N_f) can be read directly from scale 1 (fig. 7).

Scale 2 provides life factors (L_f) for practical life requirements, where:

$$L_f = \frac{C_N}{1.44P} \quad \text{or} \quad L_f = \frac{N_f(C_E)}{1.44P}$$

Frequently it is necessary to determine the minimum bearing capacity that will meet a specific application requirement. For this purpose, formula 4 is rewritten:

$$C_E = P \left(\frac{N \times L_{10}}{16700} \right)^{1/3} \quad \text{Formula 8}$$

BEARING LIFE UNDER VARYING LOADS AND SPEEDS

In many applications, bearings are required to run at a number of different loads and speeds. If the different loads and speeds and the portions of time that are in effect are known, the life can be found from the following relation:

$$L_r = \frac{1}{\frac{p_1}{L_{n_1}} + \frac{p_2}{L_{n_2}} + \frac{p_3}{L_{n_3}} + \dots + \frac{p_n}{L_{n_n}}}$$

Note: $p_1 + p_2 + p_3 + \dots + p_n = 1.0$

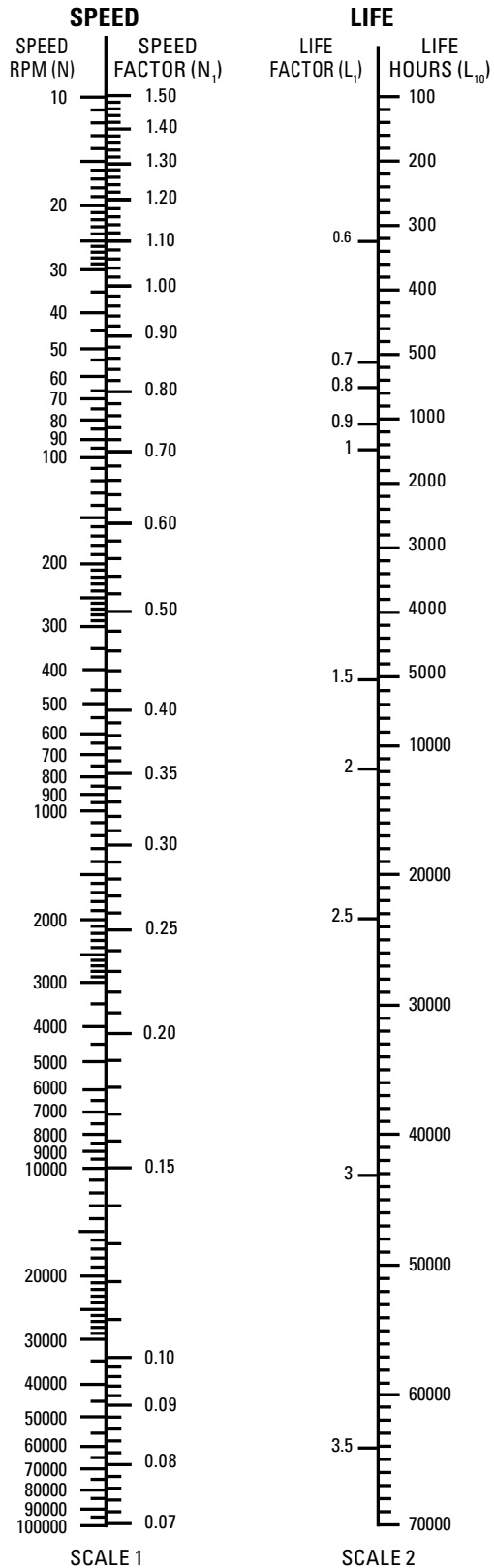

Fig. 7. Wide-inner-ring ball bearing's speed and life factors.

FREQUENCY COEFFICIENTS

Predictive application maintenance requires knowledge of the frequencies that a bearing can emit, which are based on its specific design. The table below (table 9) provides the most commonly used coefficients for this purpose. The frequencies are expressed as Orders. To obtain bearing defect frequencies in Hz, multiply the bearing coefficient by the rotating speed in revolutions per second.

Example:

9104-series bearing retainer frequency shaft running at 1200 RPM:

$$1200 \text{ RPM} \times 1 \text{ min}/60 \text{ seconds} \times 0.398 = 7.96 \text{ Hz.}$$

WIDE-INNER-RING BALL BEARINGS

FTF **Fundamental Train Frequency:** The frequency at which the retainer will operate with inner ring rotation.

BSF **Ball Spin Frequency:** The frequency at which a single defect on a rolling element will be detected.

BPFO **Ball Pass Frequency Outer:** The frequency at which a single defect in the outer race will be detected.

BPFI **Ball Pass Frequency Inner:** The frequency at which a single defect in the inner race will be detected.

OR ROT **Fundamental Train Frequency:** The frequency at which the retainer will operate with outer-ring rotation. Also know as Outer-Ring ROTation.

TABLE 9. FREQUENCY COEFFICIENTS OF WIDE-INNER-RING BALL BEARINGS

Basic Outer-Ring Size	FTF	BSF	BPFO	BPFI	OR ROT FTF	Basic Outer-Ring Size	FTF	BSF	BPFO	BPFI	OR ROT FTF
9104	0.398	2.339	3.578	5.422	0.602	303K	0.364	1.696	2.545	4.455	0.636
9105	0.397	2.328	3.574	5.426	0.603	304K	0.368	1.757	2.574	4.426	0.632
9106	0.417	2.933	4.588	6.412	0.583	305K	0.367	2.328	3.574	5.426	0.603
202K	0.391	2.175	3.125	4.875	0.609	306K	0.368	1.757	2.574	4.426	0.632
203K	0.382	1.994	3.053	4.947	0.618	307K	0.376	1.888	3.006	4.994	0.624
204K	0.382	1.992	3.052	4.948	0.618	308K	0.378	1.925	3.023	4.977	0.622
205K	0.397	2.328	3.574	5.426	0.603	309K	0.380	1.955	3.037	4.963	0.620
206K	0.396	2.311	3.568	5.432	0.604	310K	0.381	1.981	3.047	4.953	0.619
207K	0.396	2.303	3.565	5.435	0.604	311K	0.382	2.002	3.057	4.943	0.618
208K	0.394	2.256	3.547	5.453	0.606	312K	0.383	2.020	3.064	4.936	0.617
209K	0.402	2.461	3.621	5.379	0.598	314K	0.385	2.050	3.076	4.924	0.615
210K	0.409	2.665	4.093	5.907	0.591	315K	0.385	2.062	3.081	4.919	0.615
211K	0.408	2.620	4.078	5.922	0.592	316K	0.386	2.073	3.086	4.914	0.614
212K	0.407	2.584	4.066	5.934	0.593	318K	0.387	2.091	3.093	4.907	0.613
213K	0.410	2.685	4.099	5.901	0.590	318W	0.381	1.982	4.572	7.428	0.619
214K	0.410	2.702	4.104	5.896	0.590	319W	0.382	1.993	4.198	6.802	0.618
215K	0.415	2.850	4.148	5.852	0.585	320K	0.384	2.041	3.073	4.927	0.616
216K	0.417	2.923	4.585	6.415	0.583	320W	0.379	1.946	4.549	7.451	0.621
217K	0.412	2.759	4.122	5.878	0.588	321W	0.380	1.958	4.557	7.443	0.620
219W	0.410	2.692	6.562	9.438	0.590	322W	0.382	2.002	4.203	6.797	0.618
220W	0.409	2.665	6.549	9.451	0.591	326W	0.384	2.036	4.222	6.778	0.616

MOUNTING

STANDARD SERIES MOUNTING DATA

When shafts are selected for use with wide-inner-ring ball bearings, a minimum slip fit is desirable for the most satisfactory mounting. Special shaft limits are required in certain cases and a variety of standard fits can be used, including a press fit. The recommended figures are noted in table 10. In some applications, it may be permissible to use increased shaft tolerances. In such cases, applications should be forwarded to your Timken engineer for complete recommendations.

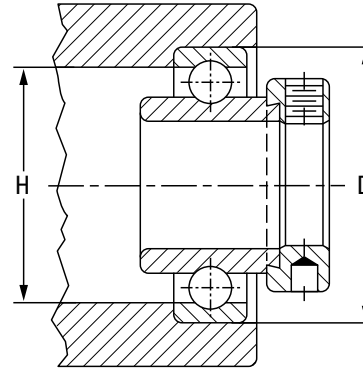

Bearing bore tolerances:

- ½ in. – 2 3/16 in., nominal to +0.013 mm, +0.0005 in.;
- 2 ¼ in. – 3 3/16 in., nominal to +0.015 mm, +0.0006 in.;

Recommended shaft tolerances:

- ½ in. – 1 15/16 in., nominal to -0.013 mm, -0.0005 in.;
- 2 in. – 2 15/16 in., nominal to -0.025 mm, -0.0010 in.

TABLE 10. HOUSING, SHOULDER AND SHAFT DIAMETERS

Bearing No.					Shaft Dia.	Basic Outer-Ring Size	Stationary Housing ⁽¹⁾			Shoulder Dia.	
KRR Type	G-KRR Type	RA-RR Type	GRA-RR Type	GYA-RR Type			Housing Bore D		Mean Fit	H	
							Max.	Min.		Loose	Max.
					in. mm		mm in.	mm in.	mm in.	mm in.	
1008KRR	–	RA008RR	GRA08RR	GYA008RR	½	203	40.015 1.5754	40.000 1.5748	0.013 0.0005	34.8 1.37	34.0 1.34
–	–	RA009RR	GRA009RR	GYA009RR	9/16						
101KRR(KR)	G1010KRR	RA010RR	GRA010RR	GYA010RR	5/8						
1011KRR	G1011KRR	–	–	–	11/16	204	47.015 1.8510	47.000 1.8504	0.013 0.0005	40.9 1.61	40.6 1.60
E17KRR	GE17KRR	RAE17RR	GRAE17RR	GYAE17RR	17						
1012KRR(KR)	G1012KRR	RA012RR	GRA012RR	GYA012RR	¾						
E20KRR	GE20KRR	RAE20RR	GRAE20RR	GYAE20RR	20	205	52.017 2.0479	51.999 2.0472	0.015 0.0006	46.0 1.81	45.7 1.80
1013KRR	–	RA013RR	GRA013RR	GYA013RR	13/16						
1014KRR	G1014KRR	RA014RR	GRA014RR	GYA014RR	7/8						
1015KRR(KR)	G1015KRR	RA015RR	GRA015RR	GYA015RR	15/16	206	62.017 2.4416	61.999 2.4409	0.015 0.0006	56.1 2.21	54.9 2.16
1100KRR(KR)	G1100KRR	RA100RR	GRA100RR	GYA100RR	1						
E25KRR	GE25KRR	RAE25RR	GRAE25RR	GYAE25RR	25						
–	G1101KRR	RA101RR	GRA101RR	GYA101RR	1 1/16	207	72.017 2.8353	71.999 2.8346	0.015 0.0006	65.0 62.7	54.9 2.47
1102KRR(KR)	G1102KRR	RA102RR	GRA102RR	GYA102RR	1 1/8						
1103KRR(KR)	G1103KRR	RA103RR	GRA103RR	GYA103RR	1 3/16						
–	–	–	–	GYA103RR2	1 ¼	207	72.017 2.8353	71.999 2.8346	0.015 0.0006	65.0 62.7	54.9 2.47
E30KRR	GE30KRR	RAE30RR	GRAE30RR	GYAE30RR	30						
1104KRR(KR)	G1104KRR	RA104RR	GRA104RR	GYA104RR	1 1/4						
1105KRR	–	RA105RR	GRA105RR	GYA105RR	1 5/16	207	72.017 2.8353	71.999 2.8346	0.015 0.0006	65.0 62.7	54.9 2.47
1106KRR	G1106KRR	RA106RR	GRA106RR	GYA106RR	1 ¾						
1107KRR(KR)	G1107KRR	RA107RR	GRA107RR	GYA107RR	1 7/16						
E35KRR	GE35KRR	RAE35RR	GRAE35RR	GYAE35RR	35						

⁽¹⁾When the housing revolves in relation to the shaft, the housing bore dimensions shown on page 131 of the Timken Engineering Manual (order no. 10424) should be used. Outer ring tolerances and housing fillet radii correspond to equivalent 200-series single-row radial bearings.

Continued on next page.

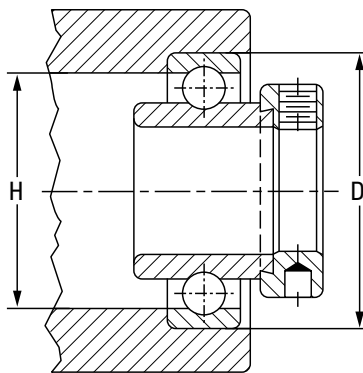

Continued from previous page.

Bearing No.					Shaft Dia.	Basic Outer-Ring Size	Stationary Housing ⁽¹⁾			Shoulder Dia.	
KRR Type	G-KRR Type	RA-RR Type	GRA-RR Type	GYA-RR Type			Housing Bore D		Mean Fit	H	
							Max.	Min.		Loose	Max.
					in. mm	mm in.	mm in.	mm in.	mm in.		
1108KRR(KR)	G1108KRR	RA108RR	GRA108RR	GYA108RR	1 1/2	208	80.018 3.1503	80.000 3.1496	0.015 0.0006	72.9 2.87	70.6 2.78
-	-	RA109RR	GRA109RR	GYA109RR	1 9/16						
-	-	-	GRAE40RR	GYAE40RR	40						
1110KRR	G1110KRR	RA110RR	GRA110RR	GYA110RR	1 5/8	209	85.024 3.3474	85.001 3.3465	0.020 0.0008	78.0 3.07	75.4 2.97
1111KRR(KR)	G1111KRR	RA111RR	GRA111RR	GYA111RR	1 11/16						
1112KRR(KR)	G1112KRR	RA112RR	GRA112RR	GYA112RR	1 3/4						
E45KRR	-	-	GRAE45RR	GYAE45RR	45	210	90.023 3.5442	90.000 3.5433	0.020 0.0008	83.1 3.27	81.0 3.19
-	-	RA113RR	GRA113RR	GYA113RR	1 13/16						
1114KRR	-	RA114RR	GRA114RR	GYA114RR	1 7/8						
1115KRR(KR)	G1115KRR	RA115RR	GRA115RR	GYA115RR	1 15/16	211	100.023 3.9379	100.000 3.9370	0.020 0.0008	90.9 3.58	90.4 3.56
-	-	-	GRA115RR2	-	2						
E50KRR	GE50KRR	RAE50RR	GRAE50RR	GYAE50RR	50						
1200KRR(KR)	G1200KRR	RA200RR	GRA200RR	GYA200RR	2	212	110.023 4.3316	110.000 4.3307	0.020 0.0008	101.1 3.98	98.3 3.87
-	-	RA201RR	GRA201RR	GYA201RR	2 1/16						
1202KRR	-	RA202RR	GRA202RR	GYA202RR	2 1/8						
1203KRR(KR)	G1203KRR	RA203RR	GRA203RR	GYA203RR	2 3/16	215	130.025 5.1191	130.000 5.1181	0.023 0.0009	120.9 4.76	116.6 4.59
E55KRR	GE55KRR	RAE55RR	GRAE55RR	GYAE55RR	55						
1204KRR	-	-	-	-	2 1/4						
1207KRR(KR)	G1207KRR	-	-	-	2 7/16	215	130.025 5.1191	130.000 5.1181	0.023 0.0009	120.9 4.76	116.6 4.59
E60KRR	GE60KRR	-	-	-	60						
1215KRR	-	-	-	-	2 15/16						
E75KRR	-	-	-	-	75						

⁽¹⁾When the housing revolves in relation to the shaft, the housing bore dimensions shown on page 131 of the Timken Engineering Manual (order no. 10424) should be used. Outer ring tolerances and housing fillet radii correspond to equivalent 200-series single-row radial bearings.

SNAP WIRE MOUNTING

KR-KRR SERIES

When shafts are selected for use with wide-inner-ring ball bearings, a minimum slip fit is desirable for the most satisfactory mounting. Special shaft limits are required in certain cases and a variety of standard fits can be used, including a press fit. The recommended figures are noted in table 11. For requirements, contact your Timken engineer.

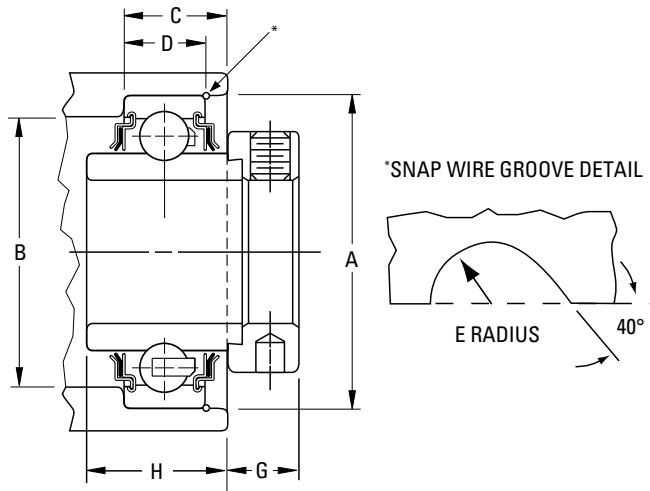
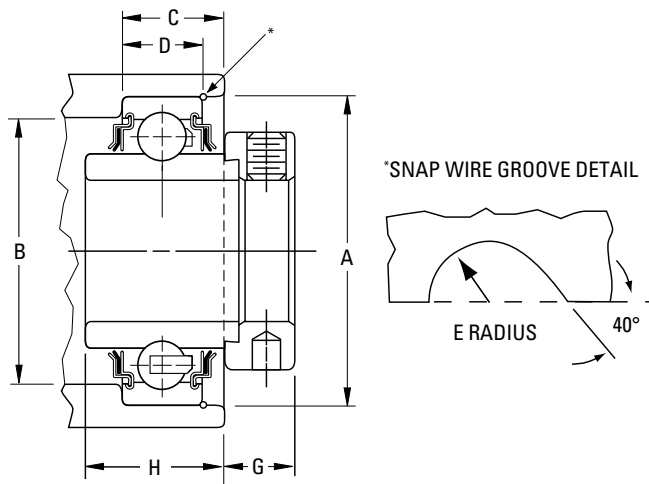

TABLE 11. R-SEAL STANDARD KR, KRR SERIES

Bearing No.	Shaft Dia.	Basic Outer-Ring Size	Housing Bore		Shoulder Dia.		C	D	Radius		
			Stationary Housing A ⁽¹⁾		B				E	G	H
			Max.	Min.	Max.	Min.					
	in. mm		mm in.	mm in.	mm in.	mm in.	mm in.	mm in.	mm in.	mm in.	
1008KRR	1/2	203	40.015 1.5754	40.000 1.5748	36.6 1.44	35.8 1.41	17.5 11/16	9.1 23/64	1.2 3/64	11.9 15/32	25.4 1
—	9/16										
1010KRR(KR)	5/8										
1011KRR	11/16										
E17KRR	17										
1012KRR(KR)	3/4	204	47.015 1.8510	47.000 1.8504	43.7 1.72	41.1 1.62	19.0 3/4	15.1 19/32	1.2 3/64	14.7 37/64	29.0 1 9/64
E20KRR	20										
1013KRR(KR)	13/16	205	52.017 2.0479	51.999 2.0472	48.5 1.91	46.7 1.84	20.6 13/16	15.9 5/8	1.2 3/64	13.9 35/64	30.6 1 13/64
1014KRR	7/8										
1015KRR(KR)	15/16										
1100KRR(KR)	1										
E25KR	25										
—	1 1/16	206	62.017 2.4416	61.999 2.4409	57.9 2.28	56.4 2.22	21.4 27/32	17.1 43/64	1.2 3/64	16.7 21/32	31.8 1 1/4
1102KRR(KR)	1 1/8										
1103KRR(KR)	1 3/16										
1103KRR3	1 1/4										
E30KRR	30										
1104KRR(KR)	1 1/4	207	72.017 2.8353	71.999 2.8346	67.6 2.66	64.3 2.53	23.0 29/32	18.3 23/32	1.6 1/16	17.9 45/64	33.3 1 15/16
1105KRR	1 5/16										
1106KRR	1 3/8										
1107KRR(KR)	1 7/16										
E35KRR	35										

⁽¹⁾When the housing revolves in relation to the shaft, the housing bore dimensions shown on page 131 of the Timken Engineering Manual (order no. 10424) should be used. Outer ring tolerances and housing fillet radii correspond to equivalent 200-series single-row radial bearings.

Continued on next page.



Continued from previous page.

Bearing No.	Shaft Dia.	Basic Outer-Ring Size	Housing Bore		Shoulder Dia.		C	D	Radius	G	H
			Stationary Housing A ⁽¹⁾		Max.	Min.			E		
			Max.	Min.							
	in. mm		mm in.	mm in.	mm in.	mm in.	mm in.	mm in.	mm in.	mm in.	
1108KRR(KR)	1 1/2	208	80.078	80.000	75.4	71.4	24.6	19.4	1.6	19.4	36.9
1109KRR	1 9/16		3.1503	3.1496	2.97	2.81	31/32	49/64	1/16	49/64	1 29/64
E40KRR	40										
1110KRR	1 5/8	209	85.024	85.001	80.3	77.0	25.4	20.2	1.6	19.0	37.3
1111KRR(KR)	1 11/16		3.3474	3.3465	3.16	3.03	1	51/64	1/16	3/4	1 15/32
1112KRR(KR)	1 3/4										
E45KRR	45										
1114KRR	1 7/8	210	90.023	90.000	83.1	82.3	26.2	21.4	1.6	21.8	40.9
1115KRR(KR)	1 15/16		3.5442	3.5433	3.27	3.24	1 1/32	37/32	1/6	55/64	1 39/64
E50KRR	50										
1200KRR(KR)	2	211	100.023	100.000	93.7	90.4	26.2	22.2	1.6	26.2	45.2
1202KRR	2 1/8		3.9379	3.9370	3.69	3.56	1 1/32	7/8	1/16	1 1/32	1 25/32
1203KRR(KR)	2 3/16										
E55KRR	55										
1204KRR	2 1/4	212	110.023	110.000	101.1	99.6	28.6	23.0	1.6	29.4	48.4
1207KRR(KR)	2 7/16		4.3316	4.3307	3.98	3.92	1 1/8	29/32	1/16	1 5/32	1 29/32
E60KRR	60										

⁽¹⁾When the housing revolves in relation to the shaft, the housing bore dimensions shown on page 131 of the Timken Engineering Manual (order no. 10424) should be used. Outer ring tolerances and housing fillet radii correspond to equivalent 200-series single-row radial bearings.

G-KRR SERIES

When shafts are selected for use with wide-inner-ring ball bearings, a minimum slip fit is desirable for the most satisfactory mounting. Special shaft limits are required in certain cases and a variety of standard fits can be used, including a press fit. The recommended values are in table 12. For special requirements, contact your Timken engineer.

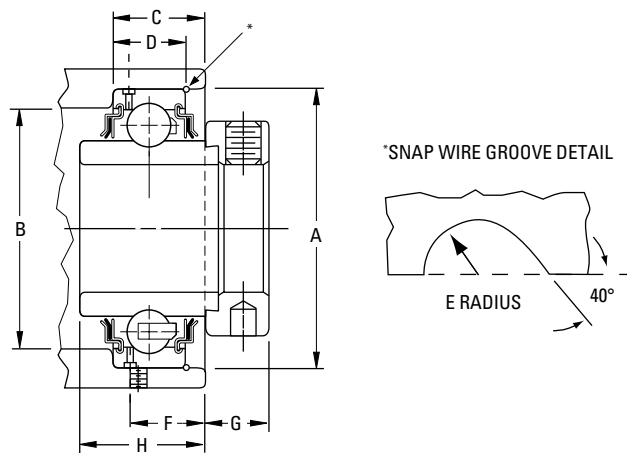

TABLE 12. R-SEAL STANDARD G-KRR SERIES

Bearing No.	Shaft Dia.	Basic Outer-Ring Size	Housing Bore		Shoulder Dia.		C	D	Radius E	F	G	H										
			Stationary Housing A ⁽¹⁾		B																	
			Max.	Min.	Max.	Min.																
	in.		mm	mm	mm	mm	mm	mm	mm	mm	mm	mm										
	mm		in.	in.	in.	in.	in.	in.	in.	in.	in.	in.										
G1010KRR	5/8	203	40.015	40.000	36.6	35.8	17.5	13.1	1.2	14.7	11.9	25.4										
G1011KRR	11/16		1.5754	1.5748	1.44	1.41	11/16	33/64	3/64	37/64	15/32	1										
GE17KRR	17																					
G1012KRR	3/4	204	47.015	47.000	43.7	41.1	19.0	15.1	1.2	15.9	14.7	29.0										
GE20KRR	20		1.8510	1.8504	1.72	1.62	3/4	19/32	3/64	5/8	37/64	1 9/64										
G1014KRR	7/8	205	52.017	51.999	48.5	46.7	20.6	15.9	1.2	16.7	13.9	30.6										
G1015KRR	15/16												2.0479	2.0472	1.91	1.84	13/16	5/8	3/64	21/32	35/64	1 13/64
G1100KRR	1																					
GE25KRR	25																					
G1101KRR	1 1/16	206	62.017	61.999	57.9	56.4	23.8	19.0	1.2	19.8	15.5	32.9										
G1102KRR	1 1/8												2.4416	2.4409	2.28	2.22	15/16	3/4	3/64	25/32	39/64	1 19/64
G1103KRR	1 3/16																					
GE30KRR	30																					
G1104KRR	1 1/4	207	72.017	71.999	67.6	64.3	25.4	20.2	1.6	21.4	16.7	34.5										
G1106KRR	1 3/8												2.8353	2.8346	2.66	2.53	1	51/64	1/16	27/32	21/32	1 23/64
G1107KRR	1 7/16																					
GE35KRR	35																					
G1108KRR	1 1/2	208	80.018	80.000	75.4	71.4	27.8	22.2	1.6	23.8	17.5	38.9										
G1109KRR	1 9/16												3.1503	3.1496	2.97	2.81	1 3/32	7/8	1/16	15/16	11/16	1 17/32
GE40KRR	40																					
G1110KRR	1 5/8																					
G1111KRR	1 11/16	209	85.024	85.001	80.3	77.0	28.6	23.4	1.6	24.2	17.5	38.9										
G1112KRR	1 3/4												3.3474	3.3465	3.16	3.03	1 1/8	59/64	1/16	31/32	11/16	1 17/32
GE45KRR	45																					
G1115KRR	1 15/16	210	90.023	90.000	83.1	82.3	29.4	24.2	1.6	24.6	20.2	42.5										
GE50KRR	50												3.5442	3.5433	3.27	3.24	1 5/32	61/64	1/16	31/32	51/64	1 43/64
G1200KRR	2	211	100.023	100.000	93.7	90.4	31.8	26.2	1.6	26.6	24.2	47.2										
G1203KRR	2 3/16												3.9379	3.9370	3.69	3.56	1 1/4	1 1/32	1/16	1 3/64	61/64	1 55/64
GE55KRR	55																					

⁽¹⁾When the housing revolves in relation to the shaft, the housing bore dimensions shown on page 131 of the Timken Engineering Manual (order no. 10424) should be used. Outer ring tolerances and housing fillet radii correspond to equivalent 200-series single-row radial bearings.

RA-RR SERIES

When shafts are selected for use with wide-inner-ring ball bearings, a minimum slip fit is desirable for the most satisfactory mounting. Special shaft limits are required in certain cases and a variety of standard fits can be used, including even a press fit. The recommended values are in table 13. For special requirements, contact your Timken engineer.

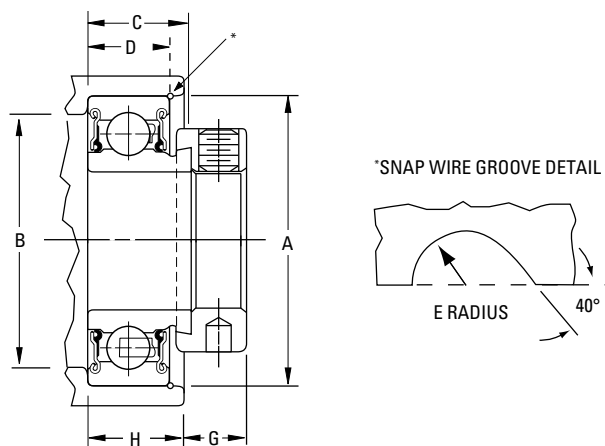
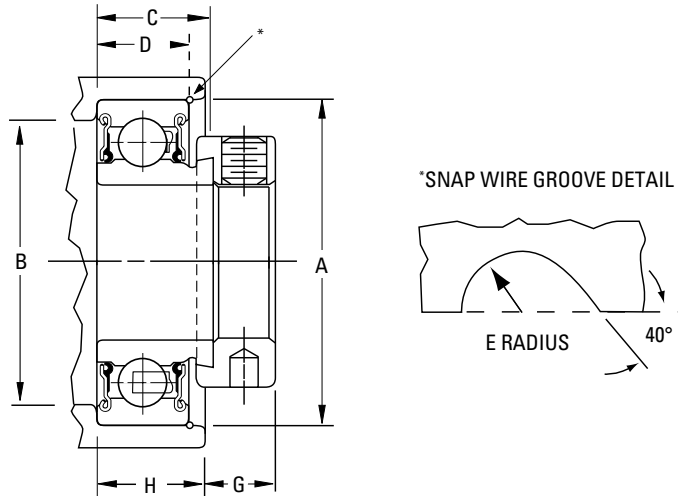

TABLE 13. RA-RR SERIES, NON-RELUBRICATABLE

Bearing No.	Shaft Dia.	Basic Outer-Ring Size	Housing Bore		Mean Fit Loose	Shoulder Dia.		C	D	H	Radius	
			Stationary Housing A ⁽¹⁾			B	Min.				E	G
			Max.	Min.								
	in. mm		mm in.	mm in.		mm in.	mm in.	mm in.	mm in.	mm in.	mm in.	
RA008RR	1/2	203	40.015 1.5754	40.000 1.5748	0.013 0.0005	1.34 35.1	1.31 34.3	19.0 3/4	14.3 9/16	16.67 21/32	1.2 3/64	9.5 3/8
RA009RR	9/16											
RA010RR	5/8											
RAE17RR	17											
RA012RR	3/4	204	47.015 1.8510	47.000 1.8504	0.013 0.0005	1.61 40.9	1.58 40.6	20.6 13/16	15.9 5/8	17.07 43/64	1.2 3/64	10.3 13/32
RAE20RR	20											
RA013RR	13/16	205	52.017 2.0479	51.999 2.0472	0.015 0.0006	1.81 46.0	1.78 45.7	20.6 13/16	15.9 5/8	17.07 43/64	1.2 3/64	10.3 13/32
RA014RR	7/8											
RA015RR	15/16											
RA100RR	1											
RAE25RR	25	206	62.017 2.4416	61.999 2.4409	0.015 0.0006	2.21 56.1	2.16 54.9	23.8 15/16	19.0 3/4	20.24 51/64	1.2 3/64	11.9 15/32
RA101RR	1 1/16											
RA102RR	1 1/8											
RA103RR	1 3/16											
RA103RR2	1 1/4	207	72.017 2.8353	71.999 2.8346	0.015 0.0006	2.56 65.0	2.47 62.7	25.4 1	20.6 13/16	22.22 7/8	1.6 1/16	13.5 17/32
RAE30RR	30											
RA104RR	1 1/4											
RA105RR	1 5/16											
RA106RR	1 3/8	208	80.018 3.1503	80.000 3.1496	0.015 0.0006	2.87 72.9	2.78 70.6	28.6 1 1/8	23.0 29/32	26.19 1 1/32	1.6 1/16	15.1 19/32
RAE35RR	35											
RA107RR	1 7/16											
RA108RR	1 1/2											
RA109RR	1 9/16	209	85.024 3.3474	85.001 3.3465	0.020 0.0008	3.07 78.0	2.97 75.4	28.6 1 1/8	23.0 29/32	26.19 1 1/32	1.6 1/16	15.1 19/32
RAE40RR	40											
RA110RR	1 5/8											
RA111RR	1 11/16											
RA112RR	1 3/4	209	85.024 3.3474	85.001 3.3465	0.020 0.0008	3.07 78.0	2.97 75.4	28.6 1 1/8	23.0 29/32	26.19 1 1/32	1.6 1/16	15.1 19/32
RAE45RR	45											

⁽¹⁾When the housing revolves in relation to the shaft, the housing bore dimensions shown on page 131 of the Timken Engineering Manual (order no. 10424) should be used. Outer ring tolerances and housing fillet radii correspond to equivalent 200-series single-row radial bearings.

Continued on next page.



Continued from previous page.

Bearing No.	Shaft Dia.	Basic Outer-Ring Size	Housing Bore		Mean Fit Loose	Shoulder Dia.		C	D	H	Radius	
			Stationary Housing A ⁽¹⁾			B					E	G
			Max.	Min.		Max.	Min.					
in.	mm	mm	mm	in.	mm	mm	mm	mm	mm	mm	mm	
RA113RR	1 13/16	210	90.023	90.000	0.020	3.27	3.17	28.6	23.0	26.19	1.6	15.1
RA114RR	1 7/8		3.5442	3.5433	0.0008	83.1	80.5	1 1/8	29/32	1 1/32	1/16	19/32
RA115RR	1 15/16											
RAE50RR	50											
RA200RR	2	211	100.023	100.000	0.020	3.68	3.56	31.0	25.4	28.18	1.6	17.5
RA201RR	2 1/16		3.9379	3.9370	0.0008	93.5	90.4	1 7/32	1	1 7/64	1/16	1 1/16
RA202RR	2 1/8											
RA203RR	2 3/16											
RAE55RR	55											

⁽¹⁾When the housing revolves in relation to the shaft, the housing bore dimensions shown on page 131 of the Timken Engineering Manual (order no. 10424) should be used. Outer ring tolerances and housing fillet radii correspond to equivalent 200-series single-row radial bearings.

GRA-RR SERIES

When shafts are selected for use with wide-inner-ring ball bearings, a minimum slip fit is desirable for the most satisfactory mounting. Special shaft limits are required in certain cases and a variety of standard fits can be used, including even a press fit. The recommended values are in table 14. For special requirements, contact your Timken engineer.

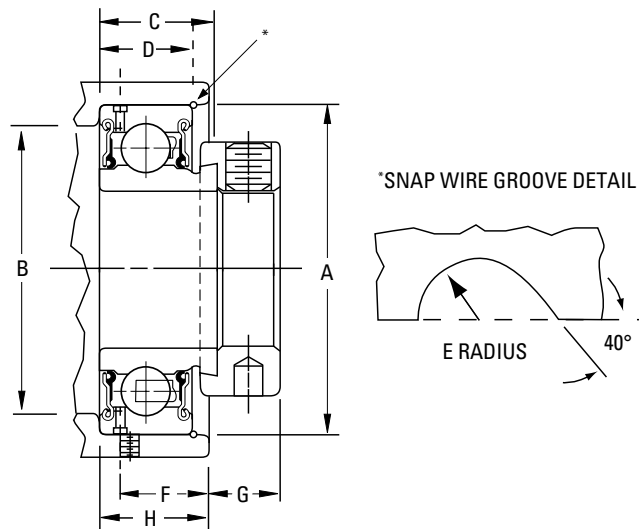

TABLE 14. GRA-RR SERIES, RELUBRICATABLE

Bearing No.	Shaft Dia.	Basic Outer-Ring Size	Housing Bore		Shoulder Dia.		C	D	H	Radius		
			Stationary Housing							E	F	G
			A ⁽¹⁾ Max.	Min.	Max.	Min.						
in.	mm	mm	in.	mm	mm	in.	mm	mm	in.	mm	mm	in.
GRA008RR	1/2	203	40.015	40.000	35.1	34.3	19.0	14.3	16.67	1.2	22.32	9.5
GRAE17RR	17		1.5754	1.5748	1.38	1.35	3/4	9/16	21/32	3/64	0.879	3/8
GRA012RR	3/4	204	47.015	47.000	40.9	40.6	20.6	15.9	17.07	1.2	25.6	10.3
GRAE20RR	20		1.8510	1.8504	1.61	1.60	13/16	5/8	43/64	3/64	1.008	13/32
GRA014RR	7/8	205	52.017	51.999	46.0	45.7	20.6	15.9	17.07	1.2	30.61	10.3
GRAE25RR	25		2.0479	2.0472	1.81	1.80	13/16	5/8	43/64	3/64	1.205	13/32
GRA101RR	1 1/16	206	62.017	61.999	56.1	54.9	23.8	19.0	20.24	1.2	37.29	11.9
GRAE30RR	30		2.4416	2.4409	2.21	2.16	15/16	3/4	51/64	3/64	1.468	15/32
GRA104RR	1 1/4	207	72.017	71.999	65.0	62.7	25.4	20.6	22.22	1.6	43.08	13.5
GRAE35RR	35		2.8353	2.8346	2.56	2.47	1	13/16	7/8	1/16	1.696	17/32

⁽¹⁾When the housing revolves in relation to the shaft, the housing bore dimensions shown on page 131 of the Timken Engineering Manual (order no. 10424) should be used. Outer ring tolerances and housing fillet radii correspond to equivalent 200-series single-row radial bearings.

INSTALLATION

Mounted ball bearings are available in a wide variety of types and sizes to accommodate a complete range of operating conditions.

These units generally have cast-iron housings and are designed for mounting on straight shafts with a slip fit. The self-locking collar and the set screw inner bearing design provides ease in mounting.

1. Ensure that the shaft is clean, free from burrs, straight and of proper diameter. The bearing should not be mounted on a worn section of the shaft. Using shafts with hardness greater than HRC 45 will reduce effectiveness of locking devices. See table 15 on page 25 for recommended shaft tolerances.
2. Align the bearing in its housing and slide the unit into position on the shaft.
3. Bolt housing tightly to its mounting supports using an appropriately sized fastener (table 17 on page 25). Flat washers should be used when installing any kind of mounted bearing. Washers should be properly sized to bolt diameter and should not be an SAE grade, which is smaller.

MOUNTED BALL BEARINGS MAY BE LOCKED INTO POSITION ON SHAFTS USING EITHER OF THE FOLLOWING METHODS

4. **Eccentric locking-collar bearings:** Slide collar over cammed end of inner ring. Rotate collar to engage cams and lock by lightly tapping with drift pin in the direction of shaft rotation. Tighten set screw to recommended torque levels as shown in table 16 on page 25.

In cases where the units are mounted vertically or where they are to assume considerable thrust loading, the unit should be placed so that the collar is forced against the inner ring by the thrust rather than away from it. In these cases, it may be advisable to spot the shaft under the set screw.

To disassemble, loosen set screw and lightly tap collar in direction opposite shaft rotation.

5. **Set screw locking bearings:** Lock bearing to the shaft by tightening each inner ring set screw incrementally to recommended torque levels as shown in table 16 on page 25. For concentric collar units, tighten each collar set screw to recommended torque levels in tables. To disassemble, loosen set screw.

INSTALLATION PROCEDURE FOR HIGH-SPEED OR HIGH-TEMPERATURE SAL/SAOL BEARINGS

- 6a. Remove housing cover gasket, bearing, spacer ring, endplates and packings. Use care when handling gasket and packings. Slide housing and one endplate along shaft. Ensure that the overflow cup, located at the base of the pillow block, is placed on the downward side of shaft rotation. Slide bearing onto shaft and into housing, with cam side outward (facing open end of housing).

Fixed mounting: Position bearing against housing shoulder and place spacer ring between bearing aligning ring face and housing cover shoulder face.

Float mounting: Position bearing in center of its floating space between housing and housing cover shoulder faces. Do not use spacer ring.

In general, it is preferable for the fixed bearing to be closest to the drive position.

- b. Follow step 4 or 5 on this page to secure bearing to shaft.
- c. Replace gasket and housing cover.
- d. Install packings and endplates. Tighten screws holding endplates to force packings into contact with shaft. This creates an effective seal.
- e. To disassemble, reverse the above operations to remove bearing from the shaft.

NOTE

Do not overtighten packings. If considerable heat develops during operation, loosen packings by loosening the screws holding endplate.



WARNING

Failure to observe the following warnings could create a risk of death or serious injury.

Proper maintenance and handling practices are critical. Always follow installation instructions and maintain proper lubrication.

TECHNICAL DATA

This section provides useful installation details related to shaft tolerance and torque for set screws and bolts.

TABLE 15. SUGGESTED SHAFT TOLERANCE⁽¹⁾

Shaft Size		Tolerance
in.	mm	
1/2 - 1 15/16	12.7 - 49.2	nominal to -0.0005 in., -0.013 mm
2 - 3 15/16	50.8 - 100.0	nominal to -0.0010 in., -0.025 mm
above 4	101.6	nominal to -0.0015 in., -0.038 mm

⁽¹⁾These are for normal service; for heavy loads, high speeds or vertical shaft applications, reduce the suggested shaft tolerance by half.

TABLE 16. SUGGESTED SET SCREW TIGHTENING TORQUE

Set Screw Size	Standard Steel	Stainless Steel (TDCF inserts)
in.	in. - lbs.	in. - lbs.
#10	35	23
1/4	80	60
5/16	155	122
3/8	275	213
7/16	425	340
mm	Nm	Nm
M5	4.0	3.1
M6	6.6	4.9
M8	15.3	11.5
M10	30.0	22
M12	49.0	37

TABLE 17. SUGGESTED BOLT MOUNTING TORQUE

Bolt Size	Torque
in.	ft. - lbs.
3/8	27
1/2	65
5/8	130
3/4	230
7/8	573
1	858
1 1/8	1059
mm	Nm
M10	44
M12	77
M16	192
M20	372

SELECTION GUIDE FOR APPLICATIONS

MOUNTED BALL BEARINGS

This is a general guide. For operating conditions outside the ranges identified in table 18, consult your Timken engineer.

TABLE 18. APPLICATION FACTOR

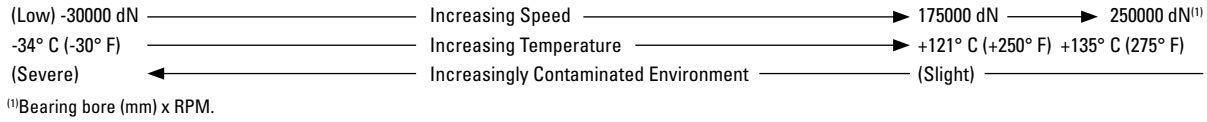

Table 19 is an application selection guide for mounted ball bearings.

TABLE 19. MOUNTED BALL BEARINGS SELECTION GUIDE FOR APPLICATIONS

Load	Bearing Types																		
	Wide Inner Ring Ball Bearing with Tri-ply Seals Self-Locking Collar		Wide-Inner-Ring Ball Bearing With Contact Seals Self-Locking Collar				Extended Inner Ring Bearing with Contact Seals Self-Locking Collar				Wide-Inner-Ring Ball Bearing with Contact Seals Set Screw Lock			Narrow Width Bearing with Contact Seals Set Screw Lock			Wide-Inner-Ring Ball Bearing with Labyrinth or Special Seals Self-Locking Collar		
	Housing Type		Housing Type				Housing Type				Housing Type			Housing Type			Housing Type		
	Pillow Block	Flange Unit	Pillow Block	Flange Unit	Take-Up Unit	Cartridge	Pillow Block	Flange Unit	Take-Up Unit	Cartridge	Pillow Block	Flange Unit	Take-Up Unit	Pillow Block	Flange Unit	Take-Up Unit	Pillow Block	Flange Unit	Take-Up Unit
Light Duty							PB ⁽¹⁾	LFST ⁽¹⁾	MSTU ⁽¹⁾	RCSM ⁽¹⁾									
							PBS ⁽¹⁾	VFMST ⁽¹⁾		RCR ⁽¹⁾									
							RBG(U)	RBGF		LCR ⁽¹⁾									
							RPB ⁽¹⁾	RA, RAT ⁽¹⁾		RABR ⁽¹⁾									
								RATR ⁽¹⁾											
								GRA											
Normal Duty	TAK	TCJ	RAK	RCJ		RC	VAK	VCJ	VTU		YAS	YCJ	YTU	SAS	SCJ	STU	LAK	LCJ	LTU
	TAS	TCJT	RAS	RCJT			VAS	VCJT	VNTU		YAK	YCJT		SAK	SCJT		LAS	LCJT	
			RAKH			RTU	VTB				YTB	RCJC		STB			LSA		
			RAKHL ⁽²⁾	GFRTD(R)		TU			FLCT ⁽¹⁾		RASC	RCJTC					SAL ⁽³⁾		
			DRNR	RFTD(R) ⁽¹⁾					GVFTD(R)				RFC				LAKHL		
				GRFD(R)					VFTD(R) ⁽¹⁾										
			RFD(R) ⁽¹⁾					GVFD(R)				YCJTM							
								VFD(R) ⁽¹⁾			YASM	YCJM							
Heavy Duty			RAO	RCJO													LAO	LCJO	
			RSAO														LSAO		
																	SAOL ⁽³⁾		

⁽¹⁾Non-relubricatable.

⁽²⁾Float unit, grease lubrication.

⁽³⁾Fixed and floating. Oil lubrication, SAL and SAOL units, with adjustable seal packages also can be considered for adverse environments.

NOTE: All bearings or units are double sealed and prelubricated with grease except where noted.

WIDE-INNER-RING BALL BEARINGS

Wide-inner-ring ball bearings consist of a single-row ball bearing and an extended inner ring. They carry radial, axial and combination loads. The extended inner ring slips onto the shaft and secures with a locking mechanism.

- **Sizes:** Standard series: 15 mm – 75 mm shaft (1/2 – 2 15/16 in.). Medium and heavy-duty series are available in larger sizes.
- **Industries and applications:** Agriculture, food processing, fans, blowers, and conveyors.
- **Features:** Available with a variety of shaft locking systems: eccentric locking collars, set screws and concentric locking collars.
- **Benefits:** Designed for ease of mounting and maximum shaft support.

Nomenclature..... 28
 Introduction..... 29

INDUSTRIAL SERIES

KR, KRR, KRRB Non-Relubricatable Types 34
 G-KRR, G-KRRB Relubricatable Types 36
 KL, KLB, KLL, KLLB Special Series,
 Non-Relubricatable Types 38
 G-KLL, G-KLLB Special Series, Relubricatable Types 39
 KLLG Special Series with Wireloc® 40
 Tri-Ply Industrial Series,
 Non-Relubricatable and Relubricatable Types..... 41
 GC-KRRB Industrial-Series Concentric Collar,
 Relubricatable Type..... 42
 SM Industrial Series A and B Types/MUA-B Inserts..... 43
 SM-S Industrial Series 45
 GY-KRRB Set Screw Industrial Series 46
 ER Industrial Series, Relubricatable Types 48

STANDARD SERIES

RA-RR, RA-RRB Non-Relubricatable Types..... 50
 GRA-RR, GRA-RRB Relubricatable Types 52
 RA-DD, Non-Relubricatable Types 54
 YA-RR, YA-RRB Non-Relubricatable Types 55
 GYA-RR, GYA-RRB Relubricatable Types..... 56

LIGHT SERIES

RAL-NPPB Non-Relubricatable Types..... 57

MEDIUM SERIES

GYM-KRRB Inserts Set Screw Lock..... 58

HEAVY SERIES

GN-KRRB Relubricatable Types 59
 GN-KLLB Special Duty 61
 SMN A and B Types/MUOA-B Inserts 62
 SMN-S Series..... 64

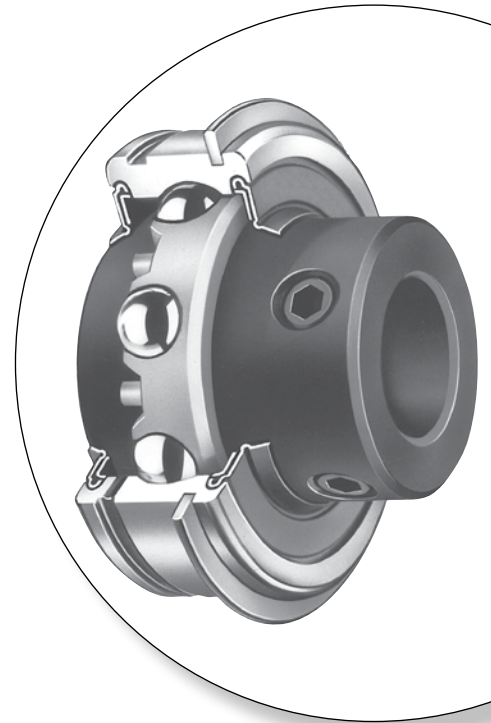

NOMENCLATURE

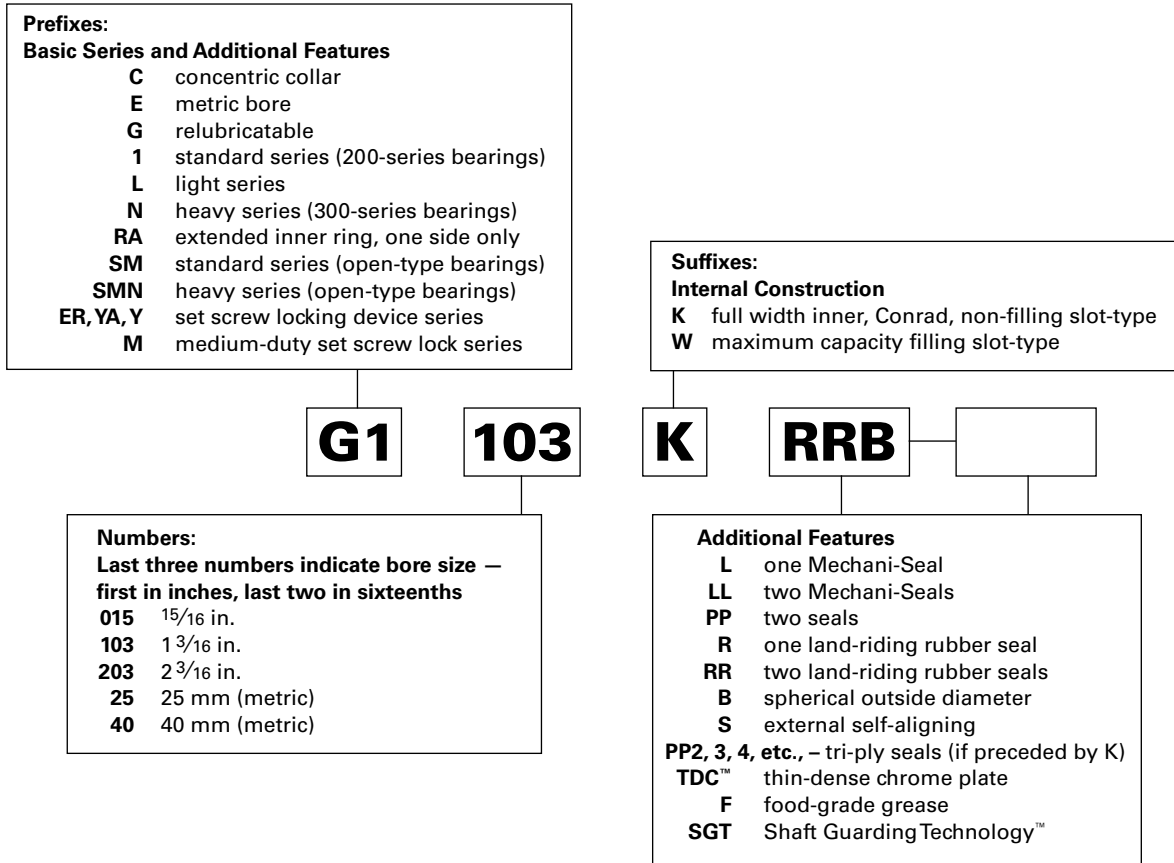

Fig. 8. Wide-inner-ring ball bearing nomenclature.

WARNING

Failure to observe the following warnings could create a risk of death or serious injury.

Proper maintenance and handling practices are critical. Always follow installation instructions and maintain proper lubrication.

Tensile stresses can be very high in tightly fitted bearing components. Attempting to remove such components by cutting the cone (inner race) may result in a sudden shattering of the component causing fragments of metal to be forcefully expelled. Always use properly guarded presses or bearing pullers to remove bearings from shafts, and always use suitable personal protective equipment, including safety glasses.

CAUTION

Failure to follow this caution could create a risk of injury.

SHAFT GUARDING TECHNOLOGY™

Do not remove band from bore groove. Removal may cause it to release suddenly.

NOTE

The products catalogued are application specific. Any use in applications other than those intended could lead to equipment failure or to reduced equipment life.

Use of improper bearing fits may cause damage to equipment.

Do not use damaged bearings. The use of a damaged bearing can result in equipment damage.

INTRODUCTION

WIDE-INNER-RING BALL BEARING DESIGN FOR BALL BEARINGS THAT ARE EASILY MOUNTED ON STRAIGHT SHAFTS AND POSITIONED WITHOUT SHOULDERS, LOCKNUTS OR ADAPTERS

The internal bearing construction is basically the same as the deep race, single-row radial type with the ability to carry radial, thrust and combined loads, while providing low-friction qualities. The inner ring is generally extended on both sides of the race to provide additional shaft support, and is locked to the shaft by specially designed set screws, an eccentric self-locking collar or a concentric collar. The wide-inner-ring ball bearings also are available with cylindrical or spherical outside diameters (O.D.). The cylindrical or straight O.D. type is used for mounting in straight-bored housings. The spherical O.D. type must be mounted in a corresponding spherical seat and is used to compensate for shaft or housing misalignments.

WIDE-INNER-RING BALL BEARINGS WITH ECCENTRIC LOCKING COLLARS

The following series are available with the eccentric cam (self-locking) collar. See installation instructions in table 20 on page 31.

RR SERIES

These bearings feature the flareout, contact-type R-seal which encloses a synthetic rubber-impregnated washer between two metal caps (fig. 9). Most sizes incorporate the shroud-seal design. R-seal wide-inner-ring ball bearings are available in the following non-relubricatable variations: KR (one seal, cylindrical O.D.), KRR (two seals, cylindrical O.D.) and KRRB (two seals, spherical O.D.). Relubricatable versions are: G-KRR, G-KRRB and GN-KRRB (heavy-duty).



Fig. 9. RR series.

RA-RR SERIES

The RA-RR series features an extended inner ring and self-locking collar for simple and effective shaft retention in a standard-series bearing (fig. 10). The positive contact, land-riding R-seal provides improved protection against the heavy contamination encountered in many applications. All sizes have a heat-stabilized, moisture-conditioned 6/6 nylon retainer, which has proven effective under conditions of misalignment. RA-RR extended inner-ring bearings are available as RA-RR (two-seals, straight O.D.) and RA-RRB (two seals, spherical O.D.). Relubricatable versions are GRA-RR and GRA-RRB.



Fig. 10. RA-RR series.

LL SERIES

These bearings are dimensionally interchangeable with the RR series, but have non-contact labyrinth seals and steel cages for low torque, high speed and higher temperature service (up to 177° C [350° F]).

TRI-PLY SEAL SERIES

Tri-ply seal bearings are designed for environments where severe conditions and moisture are present (fig. 11). The one-piece tri-ply seals incorporate a highly effective seal design molded to an exterior shroud cap. The shroud cap protects the seal lips from fiber wrap and abrasion while enhancing the overall sealing effectiveness of the unit. All units incorporate the self-locking collar and have a nylon retainer. Tri-ply seal bearings are available in both a non-relubricatable (KPPB) and relubricatable version (G-KPPB).



Fig. 11. Tri-ply seal series.

EXTERNAL SELF-ALIGNING SERIES

The construction of this series permits the inner assembly, which contains an open-type ball bearing with spherical O.D. to align in the seat of the mating outer ring (fig. 12). The seat of this outer ring is matched with the spherical O.D. of the ball bearing outer ring providing unrestricted self-alignment and allowing the inner assembly to become square and true with the shaft. Self-aligning units are available in both standard SM-S or heavy SMN-S series.



Fig. 12. External self-aligning series.

RA-DD-SERIES BEARINGS

The RA-DD-series bearings are extended inner-ring types with cam locking collars (fig. 13). They incorporate two close-fitting, non-contact grease shields to effectively retain lubricant and provide protection against harmful contaminants. The non-contact metallic shields provide improved high-speed and low-torque performance required for high-speed applications such as printing presses and tissue manufacturing. The 6/6 molded nylon retainer has proven effective under conditions of misalignment. These bearings are dimensionally interchangeable and have the same load capacities as the RA-RR series. Available in 15.88 mm – 38.10 mm ($\frac{5}{8}$ in. – 1 $\frac{1}{2}$ in.) shaft sizes.



Fig. 13. RA-DD series.

WIDE-INNER-RING BALL BEARINGS WITH CONCENTRIC COLLARS

GC SERIES

The GC series wide-inner-ring ball bearings are relubricatable with spherical outside diameters, nylon retainers and shroud seals (fig. 14). The metal shroud maintains tight seal contact against the inner ring and shields the rubber seals from damage due to dirt or fiber wrap. The concentric collar is locked to the shaft by two set screws, located 120 degrees apart, mated with threaded holes in the collar and drilled holes in the bearing inner ring.



Fig. 14. GC series.



CAM (SELF-LOCKING) COLLAR INSTALLATION INSTRUCTIONS

The self-locking collar eliminates the need for locknuts, washers, shoulders, sleeves and adapters. With various seal and inner width variations for many agricultural and industrial applications, self-locking collars are the easiest mounted bearings to install.

The locking collar has a counterbored recess made purposely eccentric to the collar bore. When assembled on the shaft, this eccentric recess engages or mates with an eccentric cam end of a bearing's inner ring. The collar is engaged on the inner cam of the bearing.

This assembly grips the shaft tightly with a positive binding action that increases with use. No adjustments of any kind are necessary. The collar set screw provides supplementary locking.

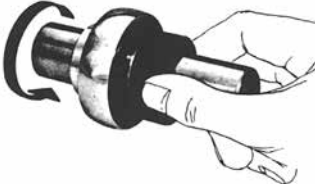
TABLE 20. CAM COLLAR INSTALLATION

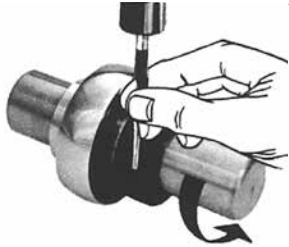
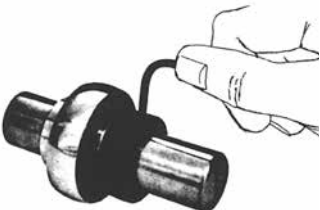
	<p>1. Observe cam design of the wide inner ring and self-locking collar.</p>
	<p>2. Mate the cam of the collar with the cam of the wide inner ring.</p>
	<p>3. Press the locking collar against the wide inner ring and turn in the direction of shaft rotation until tightly engaged.</p>
	<p>4. With drift pin in collar hole, tap lightly in direction of shaft rotation to lock.</p>
<p>For stationary shafts and outer ring rotation, turn the collar in opposite direction of rotation.</p>	<p>5. Tighten set screw in collar.</p>
	

WIDE-INNER-RING BALL BEARINGS WITH SET SCREW LOCKING DEVICE

The following series are available with the set screw locking device with special set screws that are resistant to loosening during operation.

Y SERIES

Y series bearings have full-width inner rings (fig. 15) for increased shaft support in various industrial applications, e.g. HVAC, conveyor etc. They feature superfinished raceways, grade-10 balls and anti-backout nylon patch set screws, flexible 6/6 nylon retainers and land-riding shroud seals ensure excellent performance. They are factory prelubricated and can be re-lubricated. The setscrews spaced 120° apart provide good locking and ideal for reversing applications. Bearings can be equipped with Shaft Guarding Technology™ for shaft protection (page 33), add SGT to the part number when ordering.



Fig. 15. Y series.

YA SERIES

The YA-series relubricatable and non-relubricatable bearings are an extended inner-ring type with specially designed set screws (fig. 16). Positive-contact, land-riding R-seals provide protection against harmful contaminants and retain lubricant.

Set screw series bearings are available in both non-relubricatable version YA and relubricatable version GYA-RRB. Both types have nylon retainers.



Fig. 16. YA series.

YM MEDIUM-DUTY SERIES

The Timken Fafnir medium-duty series offers reliable performance and extended life for applications that carry heavier loads (fig. 17). This series has been designed with a combination of premium features – superfinished raceways and a nylon-patch set screw locking device, designed for demanding conditions. These bearing inserts will operate with reduced levels of noise, vibration and friction and are the choice antifriction component for saw and paper mill applications, fan and blower assemblies, food and grain handling, and conveyor systems.



Fig. 17. YM series.

ER SERIES

This series offers industry-standard mounting dimensions and standard nomenclature for a large variety of sizes of relubricatable, extended inner-ring bearings for through-bored housings (fig. 18). All bearings in this series have nylon retainers and are equipped with snap rings, eliminating the need for machining housing shoulders. ER bearings are designed with a unique set screw locking device that locks the bearing to the shaft and is resistant to loosening during operation. Positive-contact, land-riding R-seals provide protection against harmful contaminants and retain lubricant. All ER bearings are black-oxide-coated for corrosion resistance. Ideal for low-starting and running-torque applications. To protect the shaft with Shaft Guarding Technology (page 33), add suffix SGT to the part number when ordering.



Fig. 18. ER series.

SHAFT GUARDING TECHNOLOGY™ FOR SET SCREW LOCKING DEVICES

Mounted bearings with Timken Shaft Guarding Technology use a stainless-steel, hardened band to transfer gripping pressure on the shaft. Unlike traditional set screws, which can dig into the shaft, there are no nicks, raised metal or permanent shaft damage when using Shaft Guarding Technology. The stainless band won't corrode on the shaft.

Timken Shaft Guarding Technology is designed to exceed gripping application requirements, maintain dimensional integrity and reduce fretting corrosion. This is a preferred solution when shaft replacement is costly.

Mounted bearings with Shaft Guarding Technology™:

- Are faster and easier to install and remove.
- Reduce the number of shaft replacements.
- Decrease overall system costs.

Tight grip offers protection.

- Two set screws and a nylon patch at a 90-degree separation provide strong holding capability with minimal distortion.
- Groove running beneath the set screws in the inner ring bore keeps the band in place.
- Hardened stainless-steel band helps protect the shaft from damage.
- Longer inner ring along the shaft (ABMA compliant) improves shaft support and reduces bearing misalignment.
- Timken thin-dense chrome (TDC™) optional.
- Seal options include three-piece R-seal for normal-to-high contamination environments and L-seal for higher speeds and temperatures.
- Choice of housing configurations.

Industries and applications:

- Rubber and plastic.
- Agriculture (combines and implements).
- Forest products (paper, tissue, newsprint, fine paper).
- Industrial machinery.
 - Fans and blowers.
 - Canning and bottling.
 - Conveyors.
 - Food processing.
 - Printing presses.
 - Packaging.
 - Textiles.

INDUSTRIAL SERIES

KR, KRR, KRRB
NON-RELUBRICATABLE TYPES

- Designed for extremely dirty or wet conditions.
- Feature R-seals with flared lips that firmly contact the ground O.D. of the inner ring.
- R-seals provide a positive seal against dirt and other contaminants, while effectively retaining the lubricant.
- Equipped with shroud-seals, providing extra effectiveness and protection.
- Extra-wide design provides additional shaft support and extra-large grease capacity.

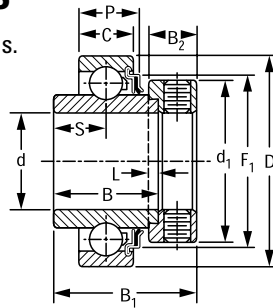

KR One Seal
Cylindrical O.D.

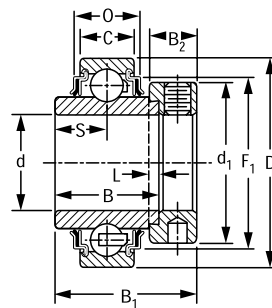

KRR Two Seals
Cylindrical O.D.

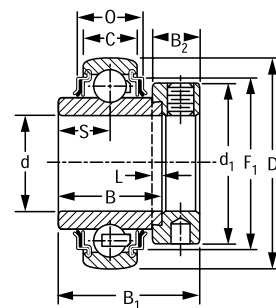

KRRB Two Seals
Spherical O.D.

Suggested shaft tolerances:

- 1/2 in. – 1 15/16 in., nominal to -0.013 mm, -0.0005 in.;
- 2 in. – 2 15/16 in., nominal to -0.025 mm, -0.0010 in.

To order, specify bearing number followed by "+ COL".

Example: 1103KRRB + COL.

Bearing No.		Collar No.	Basic Outer-Ring Size	Shaft Dia.	O.D.		Ring Widths									Brg. and Collar Wt.		Static Load Rating	Extended Dynamic Load Rating
Cylindrical O.D.	Spherical O.D.				Inner	Outer	S	L	d ₁	B ₂	B ₁	F ₁	O	P	kg	lbs.	C ₀		
				d	D	B	C	S	L	d ₁	B ₂	B ₁	F ₁	O	P	kg	lbs.	N	N
				in.	mm	mm	mm	mm	mm	mm	mm	mm	mm	mm	mm	kg	lbs.	N	N
-	1008KRR (KRRB)	S1008K		1/2												0.154	0.34		
1010KR	1010KRR (KRRB)	S1010K	203	5/8	40	27.78	12	13.90	4.0	28.6	13.5	37.3	34.01	16.56	14.27	0.145	0.32	4700	10700
-	1011KRR (KRRB)	S1011K		11/16	1.5748	1 3/32	0.472	35/64	5/32	1 1/8	17/32	1 15/32	1.339	0.652	0.562	0.122	0.27	1060	2400
-	E17KRR (KRRB)	SE17K		17												0.122	0.27		
1012KR	1012KRR (KRRB)	S1012K	204	3/4	47	34.13	14	17.10	4.0	33.3	13.5	43.7	38.91	16.56	15.29	0.204	0.45	6200	14300
-	E20KRR (KRRB)	SE20K		20	1.8504	1 11/32	0.551	43/64	5/32	1 5/16	17/32	1 23/32	1.532	0.652	0.602	0.204	0.45	1400	3200
-	1013KRR (KRRB)	S1013K		13/16												0.286	0.63		
-	1014KRR (KRRB)	S1014K		7/8												0.272	0.60		
1015KR	1015KRR (KRRB)	S1015K	205	15/16	52	34.92	15	17.50	4.0	38.1	13.5	44.1	45.19	16.66	15.82	0.254	0.56	7700	15800
1100KR	1100KRR (KRRB)	S1100K		1	2.0472	1 3/8	0.591	11/16	5/32	1 1/2	17/32	1 47/64	1.779	0.656	0.623	0.231	0.51	1730	3550
-	E25KRR (KRRB)	SE25K		25												0.231	0.51		
-	1101 (KRRB)	S1101K		1 1/16												0.413	0.91		
1102KR	1102KRR (KRRB)	S1102K		1 1/8												0.404	0.89		
1103KR	1103KRR (KRRB)	S1103K	206	1 3/16	62	36.51	16	18.30	4.0	44.4	15.9	48.4	52.53	19.56	17.78	0.376	0.83	11100	21200
-	1103KRR3 (KRRB3)	S1103K3		1 1/4	2.4409	1 7/16	0.630 ⁽¹⁾	23/32	5/32	1 3/4	5/8	1 29/32	2.068	0.770	0.700	0.349	0.77	2500	4900
-	E30KRR (KRRB)	SE30K		30												0.376	0.83		
1104KR	1104KRR (KRRB)	S1104K		1 1/4												0.653	1.44		
-	1105KRR (KRRB)	S1105K		1 5/16												0.603	1.33		
-	1106KRR (KRRB)	S1106K	207	1 3/8	72	37.70	17	18.85	4.0	54.0	17.1	51.2	60.55	19.69	18.34	0.572	1.26	15100	28500
1107KR	1107KRR (KRRB)	S1107K		1 7/16	2.8346	1 31/64	0.669 ⁽²⁾	0.742	5/32	2 1/8	43/64	2 1/64	2.384	0.775	0.722	0.544	1.20	3400	6400
-	E35KRR (KRRB)	SE35K		35												0.572	1.26		

⁽¹⁾Spherical O.D. outer-ring width is 18 mm (0.709 in.).

⁽²⁾Spherical O.D. outer-ring width is 19 mm (0.748 in.).

⁽³⁾Spherical O.D. outer-ring width is 21 mm (0.827 in.).

⁽⁴⁾Available with spherical O.D. To order, add suffix B. Example 1115KRRB.

⁽⁵⁾Spherical O.D. outer-ring width is 22 mm (0.866 in.).

NOTE: Bore tolerances: 1/2 in. – 2 3/16 in. nominal to +0.013 mm, +0.0005;
2 1/4 in. – 2 15/16 in. nominal to +0.015 mm, +0.0006 in.

Continued on next page.

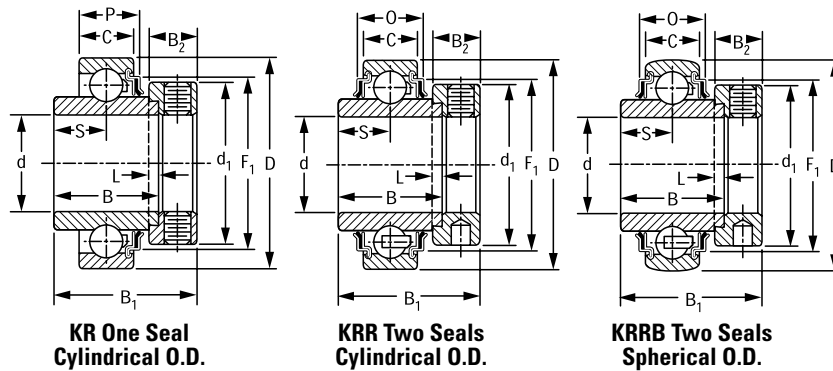

Continued from previous page.

Bearing No.		Collar No.	Basic Outer-Ring Size	Shaft Dia.	O.D.	Ring Widths										Brg. and Collar Wt.		Static Load Rating	Extended Dynamic Load Rating	
Cylindrical O.D.	Spherical O.D.					Inner	Outer	S	L	d ₁	B ₂	B ₁	F ₁	O	P	kg	lbs.			C ₀
				d	D	B	C	S	L	d ₁	B ₂	B ₁	F ₁	O	P					
				in.	mm	mm	mm	mm	mm	mm	mm	mm	mm	mm	mm	mm			N	N
				mm	in.	in.	in.	in.	in.	in.	in.	in.	in.	in.	in.		lbs.	lbs.	lbs.	lbs.
1108KR	1108KRR (KRRB)	S1108KT	208	1 1/2	80	42.86	18	21.40	4.8	60.3	18.3	56.4	67.79	20.45	19.28	0.789	1.74	19600	36000	
-	1109KRR (KRRB)	S1109KT		1 9/16	3.1496	1 11/16	0.709 ⁽³⁾	27/32	3/16	2 3/8	23/32	2 7/32	2.669	0.805	0.757	0.739	1.63	4400	8150	
-	E40KRR (KRRB)	SE40K		40												0.739	1.63			
-	1110KRR (KRRB)	S1110K	209	1 5/8	85	42.86	19	21.40	4.8	63.5	18.3	56.4	73.86	24.18	21.59	0.898	1.98	20000	36000	
1111KR	1111KRR (KRRB)	S1111K		1 11/16	3.3465	1 11/16	0.748	27/32	3/16	2 1/2	23/32	2 7/32	2.908	0.952	0.850	0.848	1.87	4500	8150	
1112KR	1112KRR (KRRB)	S1112K		1 3/4												0.825	1.82			
-	E45KRR (KRRB)	SE45K	45												0.825	1.82				
-	1114KRR (KRRB)	S1114K	210	1 7/8	90	49.21	20	24.60	4.8	69.9	18.3	62.7	77.7	24.51	22.25	1.057	2.33	22709	39000	
1115KR ⁽⁴⁾	1115KRR (KRRB)	S1115K		1 15/16	3.5433	1 15/16	0.787 ⁽⁵⁾	31/32	3/16	2 3/4	23/32	2 15/32	3.059	0.965	0.876	1.000	2.18	5100	8800	
-	E50KRR (KRRB)	SE50K		50												1.000	2.18			
1200KR	1200KRR (KRRB)	S1200K	211	2	100	55.56	21	27.80	4.8	76.2	20.6	71.4	87.17	27.41	24.21	1.520	3.35	28500	48000	
-	1202KRR (KRRB)	S1202K		2 1/8	3.9370	2 3/16	0.827	1 3/32	3/16	3	13/16	2 13/16	3.432	1.079	0.953	1.356	2.99	6400	10800	
1203KR	1203KRR (KRRB)	S1203K		2 3/16												1.306	2.88			
-	E55KRR (KRRB)	SE55K	55												1.306	2.88				
-	1204KRR (KRRB)	S1204K	212	2 1/4	110	61.91	22	31.00	6.4	84.1	22.2	77.8	94.89	30.02	26.01	1.715	3.78	35600	58500	
1207KR	1207KRR (KRRB)	S1207K		2 7/16	4.3307	2 7/16	0.866	1 7/32	1/4	3 5/16	7/8	3 1/16	3.736	1.182	1.024	1.565	3.45	8000	13200	
-	E60KRR (KRRB)	SE60K		60												1.615	3.56			
-	1215KRR (KRRB)	S1215K	215	2 15/16	130	74.61	25	37.30	6.4	101.6	23.8	91.2	113.13	34.03	-	2.640	5.82	43600	69500	
-	E75KRR (KRRB)	SE75K		75	5.1181	2 15/16	0.984	1 15/32	1/4	4	15/16	3 5/8	4.454	1.340		2.640	5.82	9800	15600	

⁽¹⁾Spherical O.D. outer-ring width is 18 mm (0.709 in.).

⁽²⁾Spherical O.D. outer-ring width is 19 mm (0.748 in.).

⁽³⁾Spherical O.D. outer-ring width is 21 mm (0.827 in.).

⁽⁴⁾Available with spherical O.D. To order, add suffix B. Example 1115KRRB.

⁽⁵⁾Spherical O.D. outer-ring width is 22 mm (0.866 in.).

NOTE: Bore tolerances: 1/2 in. - 2 3/16 in. nominal to +0.013 mm, +0.0005;
2 1/4 in. - 2 15/16 in. nominal to +0.015 mm, +0.0006 in.

**G-KRR, G-KRRB
RELUBRICATABLE TYPES**

- The G-KRR-series wide-inner-ring ball bearings are the same as the RR series and have a provision for relubrication.
- These bearings are designed for extremely dirty or wet conditions.
- The bearing includes R-seals with flared lips that firmly contact the ground O.D. of the inner ring. The inner ring provides a positive seal against dust, dirt and other contaminants, and effectively retains the lubricant.
- G-KRR-series bearings are equipped with shroud-seals, providing extra effectiveness and protection.
- The extra-wide design provides additional shaft support and extra-large grease capacity.

Suggested shaft tolerances:

- 1/2 in. – 1 15/16 in., nominal to -0.013 mm, -0.0005 in.;
- 2 in. – 2 15/16 in., nominal to -0.025 mm, -0.0010 in.

To order, specify bearing number followed by "+ COL".

Example: G1010KRRB + COL.

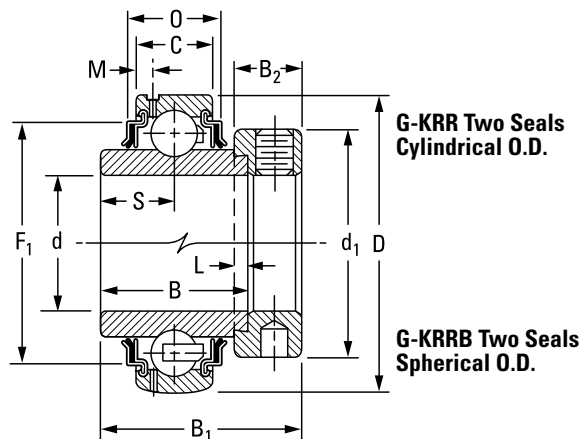

Bearing No.		Collar No.	Basic Outer-Ring Size	Shaft Dia.	O.D.	Ring Widths										Brg. and Collar Wt.	Static Load Rating	Extended Dynamic Load Rating	
Cylindrical O.D.	Spherical O.D.					Inner	Outer	S	L	d ₁	B ₂	M	B ₁	F ₁	O				C ₀
				d	D	B	C	S	L	d ₁	B ₂	M	B ₁	F ₁	O	kg	lbs.	N	N
				in.	mm	mm	mm	mm	mm	mm	mm	mm	mm	mm	mm			lbs.	lbs.
-	G1008KRRB	S1008K		1/2												0.154	0.34		
-	G1009KRRB	S1009K		9/16	40	27.78	12	13.90	4.0	28.6	13.5	2.72	37.3	34.01	16.56	0.141	0.31	4700	10700
G1010KRR	G1010KRRB	S1010K	203	5/8	1.5748	1 3/32	0.472	35/64	5/32	1 1/8	17/32	0.107	1 15/32	1.339	0.652	0.141	0.31	1060	2400
G1011KRR	G1011KRRB	S1011K		11/16												0.118	0.26		
GE17KRR	GE17KRRB	SE17K		17												0.118	0.26		
G1012KRR	G1012KRRB	S1012K	204	3/4	47	34.13	14	17.10	4.0	33.3	13.5	3.43	43.7	38.91	17.30	0.204	0.45	6200	14300
GE20KRR	GE20KRRB	SE20K		20	1.8504	1 11/32	0.551	43/64	5/32	1 5/16	17/32	0.135	1 23/32	1.532	0.681	0.204	0.45	1400	3200
-	G1013KRRB	S1013K		13/16												0.286	0.63		
G1014KRR	G1014KRRB	S1014K		7/8	52	34.92	15	17.50	4.0	38.1	13.5	3.86	44.4	45.19	16.66	0.263	0.58	7700	15800
G1015KRR	G1015KRRB	S1015K	205	15/16	2.0472	1 3/8	0.591	11/16	5/32	1 1/2	17/32	0.152	1 3/4	1.779	0.656	0.240	0.53	1730	3550
G1100KRR	G1100KRRB	S1100K		1												0.227	0.50		
GE25KRR	GE25KRRB	SE25K		25												0.227	0.50		
G1101KRR	G1101KRRB	S1101K		1 1/16												0.417	0.92		
G1102KRR	G1102KRRB	S1102K		1 1/8	62	36.51	18	18.30	4.0	44.1	15.9	3.96	48.4	52.53	21.56	0.404	0.89	11100	21800
G1103KRR	G1103KRRB	S1103K	206	1 3/16	2.4409	1 7/16	0.709	23/32	5/32	1 47/64	5/8	0.156	1 29/32	2.068	0.849	0.376	0.83	2500	4900
-	G1103KRRB3	S1103K3		1 1/4												0.349	0.77		
GE30KRR	GE30KRRB	SE30K		30												0.376	0.83		
G1104KRR	G1104KRRB	S1104K		1 1/4												0.653	1.44		
-	G1105KRRB	S1105K		1 5/16	72	37.70	19	18.85	4.0	54.0	17.1	3.68	51.2	60.55	21.74	0.617	1.36	15100	28500
G1106KRR	G1106KRRB	S1106K	207	1 3/8	2.8346	1 31/64	0.748	0.742	5/32	2 1/8	43/64	0.145	2 1/64	2.384	0.856	0.585	1.29	3400	6400
G1107KRR	G1107KRRB	S1107K		1 7/16												0.562	1.24		
GE35KRR	GE35KRRB	SE35K		35												0.585	1.29		
G1108KRR	G1108KRRB	S1108KT		1 1/2	80	42.86	21	21.40	4.8	60.3	18.3	4.06	56.4	67.79	23.44	0.812	1.79	19600	36000
-	G1109KRRB	S1109KT	208	1 9/16	3.1496	1 11/16	0.827	27/32	3/16	2 3/8	23/32	0.160	2 7/32	2.669	0.923	0.771	1.70	4400	8150
GE40KRR	GE40KRRB	SE40K		40												0.771	1.70		

⁽¹⁾Spherical O.D. outer-ring width is 22 mm, 0.866 in. 2 1/4 in. – 2 15/16 in., nominal to 0.015 mm, +0.0006 in.

⁽²⁾Spherical O.D. outer-ring width is 24 mm (0.945 in.).

NOTE: Bore tolerances: 1/2 in. – 2 3/16 in., nominal to +0.013 mm, +0.0005 in.

Continued on next page.

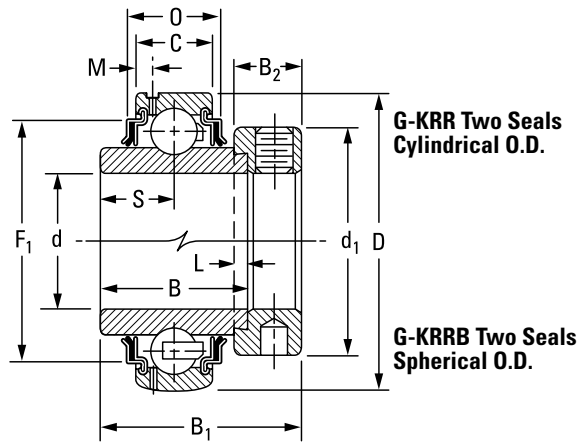

Continued from previous page.

Bearing No.		Collar No.	Basic Outer-Ring Size	Shaft Dia.	O.D.	Ring Widths										Brg. and Collar Wt.	Static Load Rating	Extended Dynamic Load Rating																	
Cylindrical O.D.	Spherical O.D.					Inner	Outer	S	L	d ₁	B ₂	M	B ₁	F ₁	O				C ₀	C _E															
				d	D	B	C	S	L	d ₁	B ₂	M	B ₁	F ₁	O	kg	lbs.	N	N																
				in.	mm	mm	mm	mm	mm	mm	mm	mm	mm	mm	mm			lbs.	lbs.																
G1110KRR	G1110KRRB	S1110K	209	1 5/8	85	42.86	22	21.40	4.8	63.5	18.3	4.55	56.4	73.86	27.18	0.925	2.04	20000	36000																
G1111KRR	G1111KRRB	S1111K		1 11/16																3.3465	1 11/16	0.866	27/32	3/16	2 1/2	23/32	0.179	2 7/32	2.908	1.07	0.880	1.94	4500	8150	
G1112KRR	G1112KRRB	S1112K		1 3/4																												0.835	1.84		
GE45KRR	GE45KRRB	SE45K		45																												0.835	1.84		
-	G1113KRR	S1113K	210	1 13/16	90	49.21	23	24.60	4.8	69.9	18.3	4.70	62.7	77.70	27.51	1.116	2.46	22700	39200																
-	G1114KRRB	S1114K		1 7/8																3.5433	1 15/16	0.903 ⁽¹⁾	31/32	3/16	2 3/4	23/32	0.185	2 15/32	3.059	1.083	1.034	2.28	5100	8800	
G1115KRR	G1115KRRB	S1115K		1 15/16																												1.016	2.24		
GE50KRR	GE50KRRB	SE50K		50																												1.016	2.24		
G1200KRR	G1200KRRB	S1200K	211	2	100	55.56	25	27.80	4.8	76.2	20.6	5.00	71.4	87.17	29.01	1.583	3.49	28500	48000																
-	G1201KRRB	S1201K		2 1/16																3.9370	2 3/16	0.983 ⁽²⁾	1 3/32	3/16	3	13/16	0.197	2 13/16	3.432	1.142	1.470	3.24	6400	10800	
-	G1202KRRB	S1202K		2 1/8																												1.406	3.10		
G1203KRR	G1203KRRB	S1203K		2 3/16																												1.365	3.01		
GE55KRR	GE55KRRB	SE55K	55													1.365	3.01																		
-	G1204KRRB	S1204K	212	2 1/4	110	61.91	27	31.00	6.4	84.1	22.2	5.13	77.8	94.89	35.03	2.041	4.50	35600	58800																
-	G1205KRRB	S1205K		2 5/16																4.3307	2 7/16	1.063	1 7/32	1/4	3 5/16	7/8	0.202	3 1/16	3.736	1.379	1.923	4.24	8000	13200	
-	G1206KRRB	S1206K		2 3/8																												1.846	4.07		
G1207KRR	G1207KRRB	S1207K		2 7/16																												1.778	3.92		
GE60KRR	GE60KRRB	SE60K	60													1.846	4.07																		
-	G1210KRRB	S1210K	214	2 5/8	125	68.26	28	34.10	6.4	96.8	23.8	5.08	79.4	109.17	35.94	2.681	5.91	43000	69500																
-	G1211KRRB	S1211K		2 11/16																4.9213	2 11/16	1.102	1 11/32	1/4	3 13/16	15/16	0.200	3 1/8	4.298	1.415	2.585	5.70	9650	15600	
-	GE70KRRB	SE70K		70																												2.585	5.70		
-	G1212KRRB	S1212K		2 3/4																												3.084	6.80		
-	G1213KRRB	S1213K	215	2 13/16	130	74.61	29	37.30	6.4	101.6	23.8	5.56	92.1	113.13	38.03	2.976	6.56	43600	69500																
-	G1214KRRB	S1214K		2 7/8																5.1181	2 15/16	1.142	1 15/32	1/4	4	15/16	0.219	3 5/8	4.454	1.497	2.867	6.32	9800	15600	
-	G1215KRRB	S1215K		2 15/16																												2.753	6.07		
-	GE75KRRB	SE75K		75																												2.753	6.07		

⁽¹⁾Spherical O.D. outer-ring width is 22 mm, 0.866 in. 2 1/4 in. - 2 15/16 in., nominal to 0.015 mm, +0.0006 in.

⁽²⁾Spherical O.D. outer-ring width is 24 mm (0.945 in.).

NOTE: Bore tolerances: 1/2 in. - 2 3/16 in., nominal to +0.013 mm, +0.0005 in.

KL, KLB, KLL, KLLB SPECIAL SERIES, NON-RELUBRICATABLE TYPES

- These wide-inner-ring ball bearings have either one or two Mechani-Seals.
- Types KLB and KLLB have spherical outside diameters permitting self-alignment when mounted in a housing with a corresponding spherical seat.
- All four types are prelubricated at the factory and require no further lubrication.
- These bearings are suitable for higher-speed and/or higher-temperature applications.
- Because they incorporate non-contact seals, these bearings have very low rotational torque.

Suggested shaft tolerances:

1/2 in. – 1 15/16 in., nominal to -0.013 mm, -0.0005 in.;
 2 in. – 2 15/16 in., nominal to -0.025 mm, -0.0010 in.

To order, specify bearing number followed by "+ COL".

Example: 1100KLL + COL.

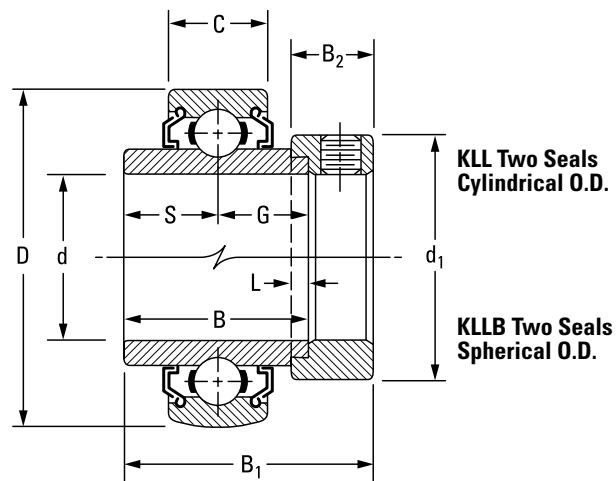

Bearing No.		Collar No.	Basic Outer-Ring Size	Shaft Dia.	O.D.	Ring Widths							Brg. and Collar Wt.		Static Load Rating	Extended Dynamic Load Rating												
Cylindrical O.D.	Spherical O.D.					Inner	Outer	S(G)	L	d ₁	B ₂	B ₁	kg	lbs.			C ₀	C _E										
				d	D	B	C	mm	mm	mm	mm	mm	mm			N	N											
				in.	mm	mm	mm	in.	in.	in.	in.	in.	in.			lbs.	lbs.											
1008KL	1008KLL (KLLB)	S1008K	203	1/2	40	27.78	12	13.89	3.97	28.58	13.49	37.31	0.168	0.37	4700	10700												
-	1009KLL	S1009K		9/16													1.5748	1 3/32	0.4724	39/64	5/32	1 1/8	17/32	1 15/32	0.163	0.36	1060	2400
1010KL	1010KLL (KLLB)	S1010K		5/8													1.5748	1 3/32	0.4724	39/64	5/32	1 1/8	17/32	1 15/32	0.141	0.31	1060	2400
1011KL	1011KLL (KLLB)	S1011K		11/16													1.5748	1 3/32	0.4724	39/64	5/32	1 1/8	17/32	1 15/32	0.122	0.27	1060	2400
1012KL	1012KLL (KLLB)	S1012K	204	3/4	47	34.13	14	17.06	3.97	33.34	13.50	43.70	0.209	0.46	6200	14300												
-	-	S1013K		13/16													1.8504	1 11/32	0.5512	43/64	5/32	1 5/16	17/32	1 23/32	0.286	0.63	1400	3200
1014KL	1014KLL (KLLB)	S1014K	205	7/8	52	34.92	15	17.46	3.97	38.10	13.49	44.45	0.277	0.61	7700	15800												
1015KL	1015KLL (KLLB)	S1015K		15/16													2.0472	1 3/8	0.5906	17/16	5/32	1 1/2	17/32	1 47/64	0.254	0.56	1730	3550
1100KL (KLB)	1100KLL (KLLB)	S1100K		1													2.0472	1 3/8	0.5906	17/16	5/32	1 1/2	17/32	1 47/64	0.250	0.55	1730	3550
1101KL	-	S1101K	206	1 1/16	62	36.51	16	18.26	3.97	44.10	15.88	48.42	0.417	0.92	11100	21800												
1102KL	1102KLL (KLLB)	S1102K		1 1/8													2.4409	1 7/16	0.6299 ⁽¹⁾	23/32	5/32	1 3/4	5/8	1 29/32	0.372	0.82	2500	4900
1103KL (KLB)	1103KLL (KLLB)	S1103K		1 3/16													2.4409	1 7/16	0.6299 ⁽¹⁾	23/32	5/32	1 3/4	5/8	1 29/32	0.372	0.82	2500	4900
1103KL3	1103KLL3 (KLLB3)	S1103K3		1 1/4													2.4409	1 7/16	0.6299 ⁽¹⁾	23/32	5/32	1 3/4	5/8	1 29/32	0.358	0.79	2500	4900
1104KL	1104KLL (KLLB)	S1104K	207	1 1/4	72	37.70	17	18.85	3.97	54.00	17.46	51.20	0.617	1.36	15100	28500												
-	1105KLL (KLLB)	S1105K		1 5/16													2.8346	1 31/64	0.6693 ⁽²⁾	0.742	5/32	2 1/8	43/64	2 1/64	0.581	1.28	3400	6400
1106KL	1106KLL (KLLB)	S1106K		1 3/8													2.8346	1 31/64	0.6693 ⁽²⁾	0.742	5/32	2 1/8	43/64	2 1/64	0.581	1.28	3400	6400
1107KL (KLB)	1107KLL (KLLB)	S1107K		1 7/16													2.8346	1 31/64	0.6693 ⁽²⁾	0.742	5/32	2 1/8	43/64	2 1/64	0.544	1.20	3400	6400
1108KL (KLB)	1108KLL (KLLB)	S1108K	208	1 1/2	80	42.86	18	21.43	4.76	60.32	18.26	56.36	0.821	1.81	17600	36200												
-	1109KLL (KLLB)	S1109K		1 9/16													3.1496	1 11/16	0.7087 ⁽³⁾	27/32	3/16	2 3/8	23/32	2 7/32	0.767	1.69	4000	8130
1110KL	1110KLL (KLLB)	S1110K	209	1 5/8	85	42.86	19	21.43	4.76	60.35	18.26	56.36	0.934	2.06	20000	36300												
1111KL	1111KLL (KLLB)	S1111K		1 11/16													3.3465	1 11/16	0.7480	27/32	3/16	2 1/2	23/32	2 7/32	0.890	1.96	4500	8160
1112KL (KLB)	1112KLL (KLLB)	S1112K		1 3/4													3.3465	1 11/16	0.7480	27/32	3/16	2 1/2	23/32	2 7/32	0.844	1.86	4500	8160
1114KL	1114KLL (KLLB)	S1114K		1 7/8													3.3465	1 11/16	0.7480	27/32	3/16	2 1/2	23/32	2 7/32	0.844	1.86	4500	8160
1115KL (KLB)	1115KLL (KLLB)	S1115K	210	1 15/16	90	49.21	20	24.61	4.76	69.90	18.26	62.71	1.075	2.37	22700	39000												
1115KL (KLB)	1115KLL (KLLB)	S1115K		1 15/16													3.5433	1 15/16	0.7874	31/32	3/16	2 3/4	23/32	2 15/32	1.021	2.25	5100	8800
1200KL (KLB)	1200KLL (KLLB)	S1200K	211	2	100	55.56	21	27.98	4.76	76.20	20.64	71.44	1.540	3.40	28500	48000												
-	1202KLL (KLLB)	S1202K		2 1/8													3.9370	2 3/16	0.8268	1 3/32	3/16	3	13/16	2 13/16	1.406	3.10	6400	10800
1203KL	1203KLL (KLLB)	S1203K		2 3/16													3.9370	2 3/16	0.8268	1 3/32	3/16	3	13/16	2 13/16	1.347	2.97	6400	10800
1207KL	-	S1207K	212	2 7/16	110	61.91	22	30.96	6.35	84.14	22.22	77.79	1.660	3.66	35600	58500												
-	1215KLL (KLLB)	S1215K		2 1/8													4.3307	2 7/16	0.8661	1 7/32	1/4	3 5/16	7/8	3 1/16	1.406	3.10	8000	13200
-	1215KLL (KLLB)	S1215K	215	2 15/16	130	74.61	25	37.31	6.35	101.6	23.81	91.08	2.268	5.00	43600	69500												
-	1215KLL (KLLB)	S1215K		2 15/16													5.1181	2 15/16	0.9843	1 15/32	1/4	4	15/16	3 5/8	1.347	2.97	9800	15600

⁽¹⁾Spherical O.D. outer-ring width is 18 mm (0.7087 in.).

⁽²⁾Spherical O.D. outer-ring width is 19 mm (0.7480 in.).

⁽³⁾Spherical O.D. outer-ring width is 21 mm (0.8268 in.).

NOTE: Bore tolerance: 1/2 in. – 2 3/16 in., nominal to +0.013 mm, +0.0005 in.
 2 7/16 in. – 2 15/16 in., nominal to +0.015 mm, +0.0006 in.

G-KLL, G-KLLB SPECIAL SERIES, RELUBRICATABLE TYPES

- These wide-inner-ring ball bearings have two Mechani-Seals and a provision for relubrication.
- Type G-KLL has a cylindrical outside diameter.
- Type G-KLLB has a spherical outside diameter.
- Both are generally suitable for higher-speed and/or higher-temperature applications.
- Because they incorporate non-contact seals, these bearings have very low rotational torque.
- Consult your Timken engineer for suggestions.

Suggested shaft tolerances:

1/2 in. – 1 15/16 in., nominal to -0.013 mm, -0.0005 in.;
 2 in. – 2 15/16 in., nominal to -0.025 mm, -0.0010 in.

To order, specify bearing number followed by "+ COL".

Example: G1015KLL + COL.

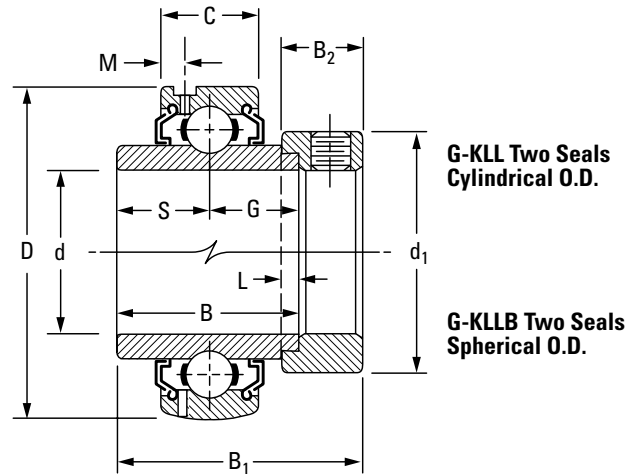

Bearing No.		Collar No.	Basic Outer-Ring Size	Shaft Dia.	O.D.	Ring Widths		S(G)	L	d ₁	B ₂	M	B ₁	Brg. and Collar Wt.	Static Load Rating	Extended Dynamic Load Rating
Cylindrical O.D.	Spherical O.D.					Inner	Outer									
				d	D	B	C	mm in.	mm in.	mm in.	mm in.	mm in.	mm in.	kg lbs.	N lbs.	N lbs.
-	G1008KLLB	S1008K		1/2										0.150	0.33	
-	G1009KLLB	S1009K		9/16	40	27.78	12	13.90	4.0	28.6	13.50	2.720	37.30	0.136	0.30	4700
G1010KLL	G1010KLLB	S1010K	203	5/8	1.5748	1 3/32	0.4724	35/64	5/32	1 1/8	17/32	0.107	1 15/32	0.141	0.31	1060
G1011KLL	G1011KLLB	S1011K		11/16										0.118	0.26	2400
G1012KLL	G1012KLLB	S1012K	204	3/4	47	34.13	14	17.10	4.0	33.3	13.50	3.430	43.70	0.200	0.44	6200
					1.8504	1 11/32	0.5512	43/64	5/32	1 5/16	17/32	0.135	1 23/32	0.286	0.63	1400
-	G1013KLLB	S1013K		13/16										0.263	0.58	7700
G1014KLL	G1014KLLB	S1014K	205	7/8	52	34.92	15	17.50	4.0	38.1	13.50	3.860	44.45	0.245	0.54	1730
G1015KLL	G1015KLLB	S1015K		15/16	2.0472	1 3/8	0.5906	11/16	5/32	1 1/2	17/32	0.152	1 3/4	0.245	0.54	3550
G1100KLL	G1100KLLB	S1100K		1										0.222	0.49	
G1101KLL	-	S1101K		1 1/16										0.422	0.93	
G1102KLL	G1102KLLB	S1102K	206	1 1/8	62	36.51	18	18.30	4.0	44.4	15.90	3.960	48.40	0.413	0.91	11100
G1103KLL	G1103KLLB	S1103K		1 3/16	2.4409	1 7/16	0.7087	23/32	5/32	1 3/4	5/8	0.156	1 29/32	0.395	0.87	2500
-	G1103KLLB3	S1103K3		1 1/4										0.340	0.75	4900
G1104KLL	G1104KLLB	S1104K		1 1/4										0.649	1.43	
-	G1105KLLB	S1105K	207	1 5/16	72	37.70	19	18.85	4.0	54.0	17.46	3.430	51.20	0.622	1.37	15100
G1106KLL	G1106KLLB	S1106K		1 3/8	2.8346	1 31/64	0.7480	0.742	5/32	2 1/8	11/16	0.135	2 1/64	0.590	1.30	3400
G1107KLL	G1107KLLB	S1107K		1 7/16										0.549	1.21	6400
G1108KLL	G1108KLLB	S1108KT	208	1 1/2	80	42.86	21	21.40	4.8	60.3	18.30	4.060	56.40	0.826	1.82	17600
G1109KLL	G1109KLLB	S1109KT		1 9/16	3.1496	1 11/16	0.8268	27/32	3/16	2 3/8	23/32	0.160	2 7/32	0.785	1.73	4000
G1110KLL	G1110KLLB	S1110K		1 5/8										0.949	2.09	8130
G1111KLL	G1111KLLB	S1111K	209	1 11/16	85	42.86	22	21.40	4.8	63.5	18.30	4.550	56.40	0.899	1.98	20000
G1112KLL	G1112KLLB	S1112K		1 3/4	3.3465	1 11/16	0.8661	27/32	3/16	2 1/2	23/32	0.179	2 7/32	0.853	1.88	4500
-	G1113KLLB	S1113K		1 13/16										1.148	2.53	
G1114KLL	G1114KLLB	S1114K	210	1 7/8	90	49.21	23	24.60	4.8	69.9	18.30	4.700	62.70	1.090	2.40	22700
G1115KLL	G1115KLLB	S1115K		1 15/16	3.5433	1 15/16	0.9055	31/32	3/16	2 3/4	23/32	0.185	2 15/32	1.031	2.27	5100
G1200KLL	G1200KLLB	S1200K		2										1.593	3.51	
-	G1201KLLB	S1201K	211	2 1/16	100	55.56	24	27.80	4.8	76.2	20.60	5.000	71.40	1.512	3.33	28500
-	G1202KLLB	S1202K		2 1/8	3.9370	2 3/16	0.9450	1 3/32	3/16	3	13/16	0.197	2 13/16	1.416	3.12	6400
G1203KLL	G1203KLLB	S1203K		2 3/16										1.285	2.83	10800
G1204KLL	G1204KLLB	S1204K		2 1/4										2.030	4.47	
-	G1205KLLB	S1205K	212	2 5/16	110	61.91	27	31.00	6.4	84.1	22.20	5.130	77.80	1.938	4.27	35600
-	G1206KLLB	S1206K		2 3/8	4.3307	2 7/16	1.0630	1 7/32	1/4	3 5/16	7/8	0.202	3 1/16	1.852	4.08	8000
-	G1207KLLB	S1207K		2 7/16										1.789	3.94	13200
-	G1215KLLB	S1215K	215	2 15/16	130	74.61	25	37.30	6.4	101.6	23.80	5.560	91.20	2.837	6.25	43600
					5.1181	2 15/16	0.9843	1 15/32	1/4	4	15/16	0.219	3 5/8	2.837	6.25	9800

NOTE: Bore tolerance: 1/2 in. – 2 3/16 in., nominal to +0.013 mm, +0.0005 in.
 2 1/4 in. – 2 15/16 in., nominal to +0.015 mm, +0.0006 in.

KLLG SPECIAL SERIES WITH WIRELOC®

- KLLG wide-inner-ring ball bearings are the same as the KLL type, except for a snap ring, or Wireloc®, in the outer ring.
- The Wireloc mounting provides a convenient method of positively locating a bearing axially.

Suggested shaft tolerances:

- 1/2 in. – 1 15/16 in., nominal to -0.013 mm, -0.0005 in.;
- 2 in. – 2 7/16 in., nominal to -0.025 mm, -0.0010 in.

To order, specify bearing number followed by "+ COL".

Example: 1008KLLG + COL.

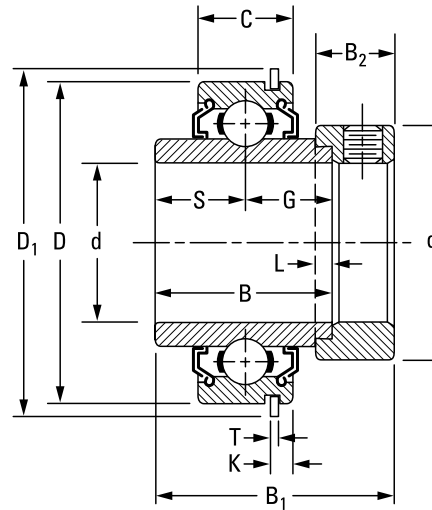

Bearing No.	Collar No.	Basic Outer-Ring Size	Shaft Dia. d	O.D. D	Ring Widths		S(G)	L	d ₁	B ₂	B ₁	Snap Ring Dimensions			Brg. and Collar Wt.		Static Load Rating C ₀	Extended Dynamic Load Rating C _E		
					Inner B	Outer C						D ₁	T	K	kg	lbs.				
				in.	mm in.	mm in.	mm in.	mm in.	mm in.	mm in.	mm in.	mm in.	mm in.	mm in.	kg	lbs.	N lbs.	N lbs.		
1008KLLG	S1008K	203	1/2	40	27.78	12	13.90	4.0	28.6	13.5	37.3	44.45	1.07	3.05	0.173	0.38	4700	10700		
1009KLLG	S1009K		9/16	1.5748	1 3/32	0.4724	35/64	5/32	1 1/8	17/32	1 15/32	1 3/4	0.042	0.120	0.154	0.34			1060	2400
1010KLLG	S1010K		5/8												0.141	0.31				
1011KLLG	S1011K		11/16												0.132	0.29				
1012KLLG	S1012K	204	3/4	47	34.13	14	17.10	4.0	33.3	13.5	43.7	52.39	1.07	3.45	0.204	0.45	6200	14300		
1013KLLG	S1013K		13/16	1.8504	1 11/32	0.5512	43/64	5/32	1 5/16	17/32	1 23/32	2 1/16	0.042	0.136	0.272	0.60			1400	3200
1014KLLG	S1014K		7/8												0.263	0.58				
1015KLLG	S1015K	15/16												0.245	0.54					
1100KLLG	S1100K	1												0.227	0.50					
1101KLLG	S1101K	206	1 1/16	62	36.51	16	18.30	4.0	44.4	15.9	48.4	67.47	1.65	4.83	0.427	0.94	11100	21800		
1102KLLG	S1102K		1 1/8	2.4409	1 7/16	0.6299	23/32	5/32	1 3/4	5/8	1 29/32	2 21/32	0.065	0.190	0.386	0.85			2500	4900
1103KLLG	S1103K		1 3/16												0.386	0.85				
1104KLLG	S1104K	1 1/4												0.645	1.42					
1105KLLG	S1105K	1 5/16												0.604	1.33					
1106KLLG	S1106K	1 3/8												0.577	1.27					
1107KLLG	S1107K	1 7/16												0.540	1.19					
1108KLLG	S1108KT	208	1 1/2	80	42.86	18	21.40	4.8	60.3	18.3	56.4	86.52	1.65	4.83	0.826	1.82	17600	36200		
1109KLLG	S1109KT		1 9/16	3.1496	1 11/16	0.7087	27/32	3/16	2 3/8	23/32	2 7/32	3 13/32	0.065	0.190	0.785	1.73			4000	8130
1110KLLG	S1110K	1 5/8												0.922	2.03					
1111KLLG	S1111K	1 11/16												0.881	1.94					
1112KLLG	S1112K	1 3/4												0.844	1.86					
1113KLLG	S1113K	1 13/16												1.035	2.28					
1114KLLG	S1114K	1 7/8												1.003	2.21					
1115KLLG	S1115K	1 15/16												0.971	2.14					
1200KLLG	S1200K	2												1.475	3.25					
1201KLLG	S1201K	211	2 1/16	100	55.56	21	27.80	4.8	76.2	20.6	71.4	106.36	2.41	5.59	1.444	3.18	28500	48000		
1202KLLG	S1202K		2 1/8	3.9370	2 3/16	0.8268	1 3/32	3/16	3	13/16	2 13/16	4 3/16	0.095	0.220	1.380	3.08			6400	10800
1203KLLG	S1203K		2 3/16												1.353	2.98				
1204KLLG	S1204K		2 1/4												1.793	3.95				
1205KLLG	S1205K	212	2 5/16	110	61.91	22	30.96	6.4	84.1	22.2	77.8	116.28	2.41	5.59	1.743	3.84	35600	58500		
1206KLLG	S1206K		2 3/8	4.3307	2 7/16	0.8661	1 7/32	1/4	3 5/16	7/8	3 1/16	4 37/64	0.095	0.220	1.711	3.77			8000	13200
1207KLLG	S1207K		2 7/16												1.684	3.71				

NOTE: Bore tolerance: 1/2 in. – 2 3/16 in., nominal to +0.013 mm, +0.0005 in.
 2 1/4 in. – 2 7/16 in., nominal to +0.015 mm, +0.0006 in.

TRI-PLY SEAL INDUSTRIAL SERIES, NON-RELUBRICATABLE AND RELUBRICATABLE TYPES

- Tri-ply seal bearings are dimensionally interchangeable with KRRB bearings and can be used with standard housings.
- One-piece tri-ply seals incorporate a highly effective seal design molded to an exterior shroud cap. The shroud cap protects the seal lip from fiber wrap and abrasion.
- Supplied with a self-locking collar, the bearings are most effective in environments with severe contamination and moisture.
- Relubricatable tri-ply seal bearings are dimensionally interchangeable with G-KRRB bearings.
- This design can be used with standard housings.

Suggested shaft tolerances:

- Heavy loads – nominal to -0.025 mm, -0.001 in.;
- Light loads – nominal to -0.050 mm, -0.002 in.

To order, specify bearing number followed by "+ COL".

Example: G1115KPPB3 + COL.

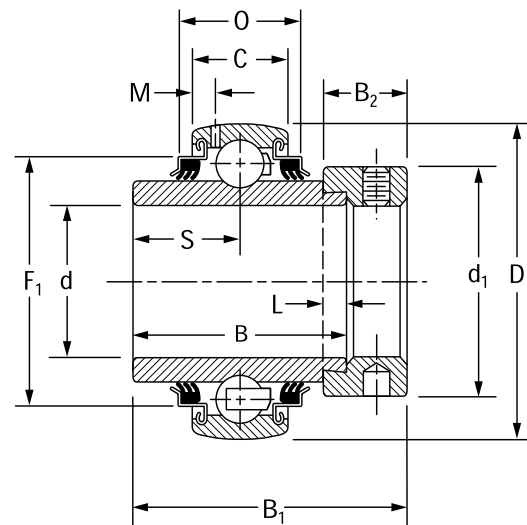

Bearing No.		Basic Outer-Ring Size	Shaft Dia.	O.D.	Ring Widths												Brg. and Collar Wt.		Static Load Rating	Extended Dynamic Load Rating
Spherical O.D.					Inner	Outer	L	d ₁	B ₂	S	B ₁	M ⁽¹⁾	F ₁	O	kg	lbs.	C ₀	C _E		
Relubricatable Type	Non-Relubricatable Type		d	D	B	C	L	d ₁	B ₂	S	B ₁	M ⁽¹⁾	F ₁	O			N	N		
			in.	mm	mm	mm	mm	mm	mm	mm	mm	mm	mm	mm			lbs.	lbs.		
G1013KPPB3	1013KPPB3	205	13/16	52	34.92	15	3.9	38.1	13.5	17.50	44.4	3.61	45.19	16.66	0.286	0.63	7700	15800		
G1014KPPB3	1014KPPB3		7/8												0.254	0.56				
G1015KPPB3	1015KPPB3		15/16												0.231	0.51				
G1100KPPB3	1100KPPB3		1												0.231	0.51				
GE25KPPB3	E25KPPB3		25												0.231	0.51				
G1101KPPB3	1101KPPB3	206	1 1/16	62	36.51	18	3.9	44.4	15.9	18.30	48.4	4.19	52.53	21.56	0.413	0.91	11100	21800		
G1102KPPB3	1102KPPB3		1 1/8												0.404	0.89				
G1103KPPB3	1103KPPB3		1 3/16												0.376	0.83				
G1103KPPB4	1103KPPB4		1 1/4												0.349	0.77				
GE30KPPB3	E30KPPB3		30												0.376	0.83				
G1104KPPB2	1104KPPB2	207	1 1/4	72	37.70	19	3.9	54.0	17.1	18.85	51.2	3.68	60.35	25.40	0.653	1.44	15100	28500		
G1105KPPB2	1105KPPB2		1 5/16												0.603	1.33				
G1106KPPB2	1106KPPB2		1 3/8												0.572	1.26				
G1107KPPB2	1107KPPB2		1 7/16												0.544	1.20				
GE35KPPB2	E35KPPB2		35												0.572	1.26				
G1108KPPB3	1108KPPB3	208	1 1/2	80	42.86	21	4.8	60.3	18.3	21.40	56.4	5.66	67.79	23.44	0.789	1.74	19800	20500		
G1109KPPB3	1109KPPB3		1 9/16												0.739	1.63				
GE40KPPB3	E40KPPB3		40												0.739	1.63				
G1110KPPB4	1110KPPB4		1 5/8												0.898	1.98				
G1111KPPB4	1111KPPB4	209	1 11/16	85	42.86	22	4.8	63.5	18.3	21.40	56.4	4.55	72.44	27.48	0.848	1.87	36200	36300		
G1112KPPB4	1112KPPB4		1 3/4												0.826	1.82				
GE45KPPB4	E45KPPB4		45												0.826	1.82				
G1113KPPB3	1113KPPB3	210	1 13/16	90	49.21	23	4.8	69.9	18.3	24.60	62.7	4.70	77.70	27.51	1.116	2.46	22700	39200		
G1114KPPB3	1114KPPB3		1 7/8												1.034	2.28				
G1115KPPB3	1115KPPB3		1 15/16												1.016	2.24				
GE50KPPB3	E50KPPB3		50												1.016	2.24				
G1200KPPB4	1200KPPB4	211	2	100	55.56	24	4.8	76.2	20.6	27.80	71.4	5.41	87.17	29.01	1.583	3.49	28500	48100		
G1201KPPB4	1201KPPB4		2 1/16												1.470	3.24				
G1202KPPB4	1202KPPB4		2 1/8												1.406	3.10				
G1203KPPB4	1203KPPB4		2 3/16												1.365	3.01				
GE55KPPB4	E55KPPB4		55												1.365	3.01				

⁽¹⁾Applies to relubricatable type only.
 NOTE: Suggested max speed – 500 RPM.
 NOTE: Bore tolerance: 19/16 in. – 23/16 in., nominal to +0.013 mm, +0.0005 in.

GC-KRRB INDUSTRIAL-SERIES CONCENTRIC COLLAR, RELUBRICATABLE TYPES

- These bearing are relubricatable with spherical outside diameters and shroud seals.
- The metal shroud maintains tight seal contact against the inner ring and shields the rubber seals from damage because of dirt or fiber wrap.
- The concentric collar is locked to the shaft by two set screws located 120 degrees apart, mated with threaded holes in the collar and drilled holes in the bearing inner ring.
- The extra-wide design provides additional shaft support and extra-large grease capacity.

Suggested shaft tolerances:

- 1/2 in. – 1 15/16 in., nominal to -0.013 mm, -0.0005 in.;
- 2 in. – 2 15/16 in., nominal to -0.025 mm, -0.0010 in.

To order, specify bearing number.

Example: GC1103KRRB + COL.

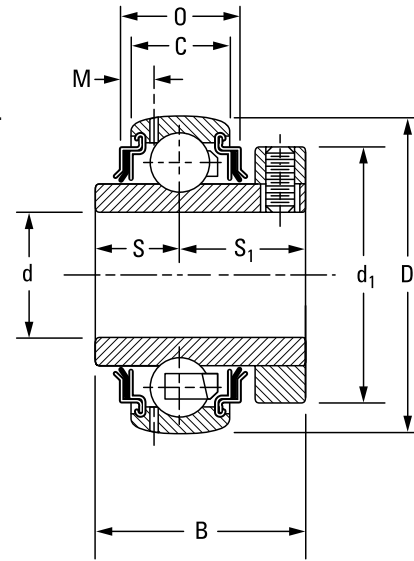

Bearing No.	Collar No.	Basic Outer-Ring Size	Shaft Dia.	O.D.	Ring Widths		S	S ₁	d ₁	M	O	Set Screw Size	Brg. and Collar Wt.	Static Load Rating	Extended Dynamic Load Rating									
					Inner	Outer																		
Spherical O.D.			d	D	B	C								C ₀	C _E									
			in.	mm	mm	mm	mm	mm	mm	mm	mm	mm	kg	N	N									
			mm	in.	in.	in.	in.	in.	in.	in.	in.	in.	lbs.	lbs.	lbs.									
GC1008KRRB	C203	203	1/2	40	26.59	12	11.1	15.5	34.1	2.72	14.71	M5x0.8	0.154	4700	10600									
GC1010KRRB			5/8										1.5748			1 3/64	0.4720	7/16	39/64	1 1/32	0.107	0.579	0.145	0.32
GC1011KRRB			1 1/16										17			1 3/64	0.4720	3 1/64	47/64	1 1/2	0.135	0.814	0.122	0.27
GCE17KRRB			17																				0.27	
GC1012KRRB	C204	204	3/4	47	30.96	14	12.3	18.7	38.1	3.43	20.68	M5x0.8	0.204	6200	14300									
GCE20KRRB			20										1.8504			1 7/32	0.5510	3 1/64	47/64	1 1/2	0.135	0.814	0.204	0.45
GC1014KRRB	C205	205	7/8	52	34.13	15	13.9	20.2	44.4	3.61	19.74	M6x1	0.272	7700	15800									
GC1015KRRB			15/16										2.0472			1 11/32	0.5905	35/64	51/64	1 3/4	0.142	0.777	0.254	0.56
GC1100KRRB			1										25			1 11/32	0.5905	35/64	51/64	1 3/4	0.142	0.777	0.231	0.51
GCE25KRRB			25																				0.51	
GC1102KRRB	C206	206	1 1/8	62	37.31	18	14.7	22.6	52.4	4.19	24.51	M6x1	0.404	11100	21800									
GC1103KRRB			1 3/16										2.4409			1 15/32	0.7090	37/64	57/64	2 1/16	0.156	0.965	0.376	0.83
GC1103KRRB3			1 1/4										30			1 15/32	0.7090	37/64	57/64	2 1/16	0.156	0.965	0.349	0.77
GCE30KRRB			30																				0.83	
GC1104KRRB	C207	207	1 1/4	72	41.28	19	15.9	25.4	59.5	3.68	25.86	M6x1	0.653	15100	28500									
GC1106KRRB			1 3/8										2.8346			1 5/8	0.7481	5/8	1	2 11/32	0.145	1.018	0.572	1.26
GC1107KRRB			1 7/16										35			1 5/8	0.7481	5/8	1	2 11/32	0.145	1.018	0.544	1.20
GCE35KRRB			35																				1.26	
GC1108KRRB	C208	208	1 1/2	80	44.05	21	16.7	27.4	68.3	5.66	28.42	M8x1.25	0.789	19800	20500									
GCE40KRRB			40										3.1496			1 47/64	0.8270	2 1/32	1 5/64	2 11/16	0.223	1.119	0.739	1.63
GC1110KRRB	C209-2	209	1 5/8	85	46.83	22	17.5	29.4	73.0	4.55	32.21	M8x1.25	0.898	36200	36300									
GC1111KRRB			1 11/16										3.3465			1 27/32	0.8660	1 11/16	1 5/32	2 7/8	0.179	1.268	0.848	1.87
GC1112KRRB	C209	209	1 3/4	90	48.42	23	18.3	30.2	79.4	4.70	32.23	M8x1.25	0.826	8130	8160									
GCE45KRRB			45										3.5433			1 29/32	0.9060	23/32	1 3/16	3 1/8	0.185	1.269	0.826	1.82
GC1115KRRB	C210	210	1 15/16	90	48.42	23	18.3	30.2	79.4	4.70	32.23	M8x1.25	0.990	22700	39200									
GCE50KRRB			50										3.5433			1 29/32	0.9060	23/32	1 3/16	3 1/8	0.185	1.269	0.990	2.18
GC1200KRRB	C211	211	2	100	53.97	24	20.6	33.3	88.9	5.41	33.73	M10x1.5	1.520	28500	48000									
GC1203KRRB			2 3/16										3.9370			2 1/8	0.9450	1 3/16	1 5/16	3 1/2	0.213	1.328	1.306	2.88
GCE55KRRB			55										2.88											
GC1207KRRB	C212	212	2 7/16	110	60.32	27	23.0	37.3	95.3	5.13	35.03	M10x1.5	1.565	35600	58800									
GCE60KRRB			60										4.3307			2 3/8	1.0630	29/32	1 15/32	3 3/4	0.202	1.379	1.565	3.45
GC1215KRRB	C215	215	2 15/16	130	70.64	29	27.0	43.7	114.3	5.59	38.25	M10x1.5	2.640	43600	69500									
GCE75KRRB			75										5.1181			2 25/32	1.1420	1 1/16	1 23/32	4 1/2	0.219	1.506	2.640	5.82

NOTE: Bore tolerances: 1 3/16 in. – 2 3/16 in., nominal to +0.013 mm, +0.0005 in.
 2 1/4 in. – 3 3/16 in., nominal to +0.015 mm, +0.0006 in.

SM INDUSTRIAL SERIES A AND B TYPES/MUA-B INSERTS⁽¹⁾

- Standard SM series A and B have the same ring tolerances and corner radii as equivalent 200-series single-row radial ball bearings.
- Type A has cylindrical outside diameters; type B has spherical outside diameters. The letter B appears on the outer ring only.
- The bearings are not prelubricated.

Suggested shaft tolerances:

1/2 in. – 1 15/16 in., nominal to -0.013 mm, -0.0005 in.;
 2 in. – 3 15/16 in., nominal to -0.025 mm, -0.0010 in.

To order, specify bearing number followed by "+ COL".

Example: SM1207KB + COL.

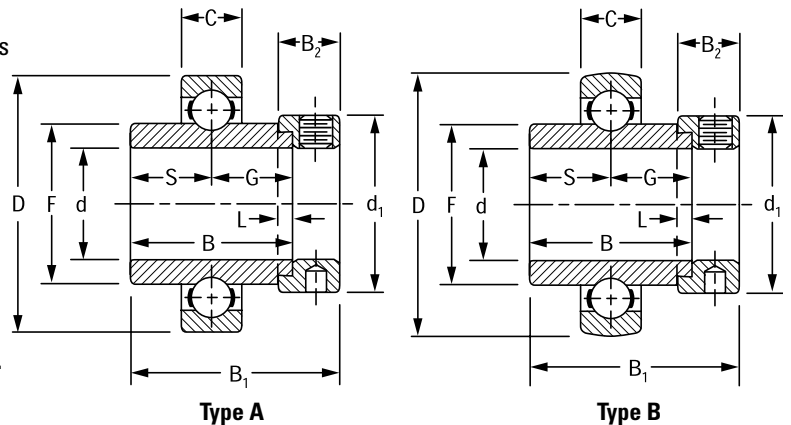

Bearing No.		Collar No.	Basic Outer-Ring Size	Shaft Dia. d	O.D. D	Ring Widths		Dimensions						Brg. and Collar Wt.		Static Load Rating C ₀	Extended Dynamic Load Rating C _E	
A Type ⁽²⁾	B Type					Inner B	Outer C	S(G)	F	L	d ₁	B ₁	B ₂	kg	lbs.			N
				in.	mm in.	mm in.	mm in.	mm in.	mm in.	mm in.	mm in.	mm in.	mm in.	mm in.	kg	lbs.	N	N
SM1008K	SM1008KB	S1008K	203	1/2											0.145	0.32		
SM1009K	SM1009KB	S1009K		9/16	40	27.78	12	13.90	22.86	4.0	28.60	37.30	13.50	0.131	0.29	4700	10600	
SM1010K	SM1010KB	S1010K		5/8	1.5748	1 3/32	0.4724	35/64	0.900	5/32	1 1/8	1 15/32	17/32	0.136	0.30	1600	2360	
SM1011K	SM1011KB	S1011K		11/16										0.113	0.25			
SM1012K	SM1012KB	S1012K	204	3/4	47	34.13	14	17.10	27.56	4.0	33.30	48.66	13.50	0.195	0.43	6200	14300	
				1 1/16	1.8504	1 11/32	0.5512	43/64	1.085	5/32	1 5/16	1 23/32	17/32	0.195	0.43	1400	3200	
SM1013K	SM1013KB	S1013K		13/16										0.276	0.61			
SM1014K	SM1014KB	S1014K		7/8	52	34.93	15	17.50	33.83	4.0	38.10	44.45	13.50	0.254	0.56	6950	15600	
SM1015K	SM1015KB	S1015K	205	15/16	2.0472	1 3/8	0.5906	11/16	1.332	5/32	1 1/2	1 3/4	17/32	0.236	0.52	1730	3450	
SM1100K	SM1100KB	S1100K		1										0.217	0.48			
SM1101K	SM1101KB	S1101K		1 1/16	62	36.51	16	18.30	40.31	4.0	44.40	48.40	15.90	0.399	0.88	11100	21600	
SM1102K	SM1102KB	S1102K		1 1/8	2.4409	1 1/16	0.6299 ⁽³⁾	23/32	1.587	5/32	1 3/4	1 29/32	5/8	0.367	0.81	2500	4800	
SM1103K	SM1103KB	S1103K	207	1 3/16										0.331	0.73			
SM1104K	SM1104KB	S1104K		1 1/4										0.621	1.37			
SM1105K	SM1105KB	S1105K		1 5/16	72	37.70	17	18.85	46.13	4.0	54.00	51.20	17.46	0.589	1.30	15100	28500	
SM1106K	SM1106KB	S1106K		1 3/8	2.8346	1 31/64	0.6693 ⁽⁴⁾	0.742	1.816	5/32	2 1/8	2 1/64	11/16	0.562	1.24	3400	6400	
SM1107K	SM1107KB	S1107K	1 7/16										0.539	1.19				
SM1108KT	SM1108KB	S1108KT	208	1 1/2	80	42.86	18	21.40	52.27	4.8	60.30	56.40	18.30	0.761	1.68	19600	36000	
SM1109KT	-	S1109KT		1 9/16	3.1496	1 11/16	0.7087 ⁽⁵⁾	27/32	2.058	3/16	2 3/8	2 7/32	23/32	0.716	1.58	4400	8150	
SM1110K	SM1110KB	S1110K	209	1 5/8										0.875	1.93			
SM1111K	SM1111KB	S1111K		1 11/16	85	42.86	19	21.40	57.92	4.8	63.50	56.40	18.30	0.857	1.89	20000	36000	
SM1112K	SM1112KB	S1112K		1 3/4	3.3465	1 11/16	0.7480	27/32	2.280	3/16	2 1/2	2 7/32	23/32	0.803	1.77	4500	8150	

⁽¹⁾See page 162.

⁽²⁾Order as MUA assembly suggested.

⁽³⁾Spherical O.D. outer-ring width is 18 mm (0.7087 in.).

⁽⁴⁾Spherical O.D. outer-ring width is 19 mm (0.7480 in.).

⁽⁵⁾Spherical O.D. outer-ring width is 21 mm (0.8268 in.).

⁽⁶⁾For applications where thrust load exceeds 60 percent of radial load, consult your Timken engineer.

NOTE: Bore tolerance: 1/2 in. – 2 3/16 in., nominal to +0.013 mm, +0.0005 in.
 2 1/4 in. – 3 3/16 in., nominal to +0.015 mm, +0.0006 in.
 3 1/4 in. – 3 15/16 in., nominal to +0.018 mm, +0.0007 in.

Continued on next page.

SM INDUSTRIAL SERIES A AND B TYPES/MUA-B INSERTS⁽¹⁾ – continued

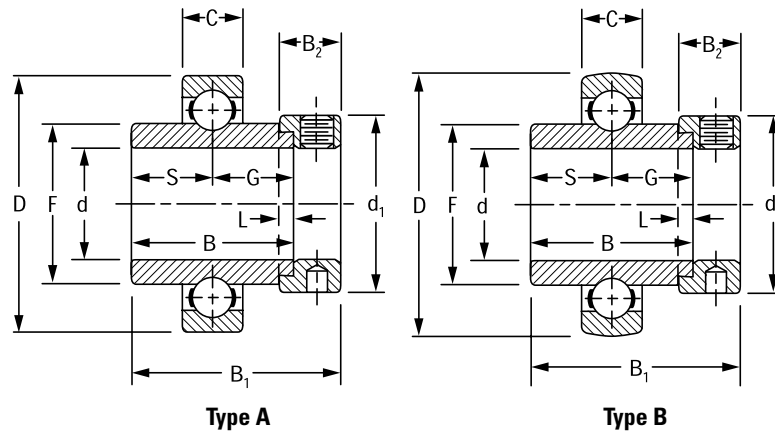

Continued from previous page.

Bearing No.		Collar No.	Basic Outer-Ring Size	Shaft Dia. d	O.D. D	Ring Widths		S(G)	F	L	d ₁	B ₁	B ₂	Brg. and Collar Wt.		Static Load Rating C ₀	Extended Dynamic Load Rating C _E
A Type ⁽²⁾	B Type					Inner B	Outer C							kg	lbs.		
				in.	mm in.	mm in.	mm in.	mm in.	mm in.	mm in.	mm in.	mm in.	mm in.	kg	lbs.	N	N
SM1113K	SM1113KB	S1113K	210	1 13/16	90	49.21	20	24.60	62.84	4.8	69.90	62.70	18.30	1.075	2.37	22700	39000
SM1114K	SM1114KB	S1114K		1 7/8	3.5433	1 15/16	0.7874	3 1/32	2.474	3/16	2 3/4	2 15/32	23/32	1.012	2.23	5100	8800
SM1115K	SM1115KB	S1115K		1 15/16										0.962	2.12		
SM1200K	SM1200KB	S1200K	211	2	100	55.56	21	27.80	69.77	4.8	76.20	71.40	20.60	1.51	3.33	28500	48000
SM1201K	SM1201KB	S1201K		2 1/16	3.9370	2 9/16	0.8268	1 3/32	2.747	3/16	3	2 13/16	1 13/16	1.397	3.08	6400	10800
SM1202K	SM1202KB	S1202K		2 1/8										1.438	3.17		
SM1203K	SM1203KB	S1203K		2 3/16										1.256	2.77		
SM1204K	SM1204KB	S1204K	212	2 1/4	110	61.91	22	30.96	76.48	6.4	84.14	77.80	22.33	1.860	4.10	35600	58500
SM1205K	SM1205KB	S1205K		2 5/16	4.3307	2 7/16	0.8661	1 7/32	3.011	1/4	3 5/16	3 1/16	7/8	1.787	3.94	8000	13200
SM1206K	SM1206KB	S1206K		2 3/8										1.692	3.73		
SM1207K	SM1207KB	S1207K		2 7/16										1.374	3.03		
SM1208K	SM1208KB	S1208K	213	2 1/2	120	68.26	23	34.13	84.58	6.4	96.84	85.73	23.81	2.472	5.45	39200	63000
				4.7244	2 11/16	0.9055		1 11/32	3.330	1/4	3 13/16	3 3/8	15/16	8800	14300		
SM1211KT	SM1211KTB	S1211KT	214	2 11/16	125	68.26	24	34.13	86.92	6.4	96.84	85.73	23.81	2.418	5.33	43000	69500
				4.9213	2 11/16	0.9449		1 11/32	3.422	1/4	3 13/16	3 3/8	15/16	9650	15600		
SM1213K	SM1213KB	S1213K	215	2 13/16	130	74.61	25	37.30	91.92	6.4	101.60	92.08	23.81	2.858	6.30	43600	68000
SM1215K	SM1215KB	S1215K		2 15/16	5.1181	2 15/16	0.9843	1 15/32	3.619	1/4	4	3 5/8	1 15/16	2.803	6.18	9800	15300
SM1303K	SM1303KB	S1303K	216	3 3/16	140	80.96	26	40.48	98.40	6.4	111.13	100.01	25.40	3.452	7.61	53400	80000
				5.5118	3 3/16	1.0236		1 19/32	3.874	1/4	4 3/8	3 15/16	1	12000	18000		
SM1307K	SM1307KB	S1307K	217	3 7/16	150	87.31	28	43.66	104.83	6.4	112.71	106.36	25.40	3.901	8.60	61000	93000
				5.9055	3 7/16	1.1024		1 23/32	4.127	1/4	4 7/16	4 3/16	1	13700	20800		
SM1311W-BR	SM1311WB-BR ⁽⁶⁾	S1311K	219	3 11/16	170	93.66	32	46.83	118.34	6.4	127.00	114.30	26.99	6.078	13.40	113600	150000
				6.6929	3 11/16	1.2598		1 27/32	4.659	1/4	5	4 1/2	1 11/16	25500	34000		
SM1315W-BR	SM1315WB-BR ⁽⁶⁾	S1315	220	3 15/16	180	100.01	34	50.00	123.85	6.4	139.70	125.41	31.75	7.335	16.17	126900	170000
				7.0866	3 15/16	1.3386		1 31/32	4.876	1/4	5 1/2	4 15/16	1 1/4	28500	38000		

⁽¹⁾See page 162.

⁽²⁾Order as MUA assembly suggested.

⁽³⁾Spherical O.D. outer-ring width is 18 mm (0.7087 in.).

⁽⁴⁾Spherical O.D. outer-ring width is 19 mm (0.7480 in.).

⁽⁵⁾Spherical O.D. outer-ring width is 21 mm (0.8268 in.).

⁽⁶⁾For applications where thrust load exceeds 60 percent of radial load, consult your Timken engineer.

NOTE: Bore tolerance: 1/2 in. – 2 3/16 in., nominal to +0.013 mm, +0.0005 in.

2 1/4 in. – 3 3/16 in., nominal to +0.015 mm, +0.0006 in.

3 1/4 in. – 3 15/16 in., nominal to +0.018 mm, +0.0007 in.

SM-S INDUSTRIAL SERIES

- Standard SM-S series permits the inner assembly to swivel in the outer aligning ring.
- The unrestricted self-alignment is achieved by allowing the inner ring to become square and true with the shaft and assembly.
- The external S-ring is uniquely ground and closely matched to its respective outer-bearing ring. The S-ring of one bearing will not fit the outer ring of another bearing.
- The bearings are not prelubricated.

Suggested shaft tolerances:

- 1 in. – 1 15/16 in., nominal to -0.013 mm, -0.0005 in.;
- 2 in. – 3 15/16 in., nominal to -0.025 mm, -0.0010 in.

To order, specify bearing number followed by "+ COL".

Example: SM1100KS + COL.

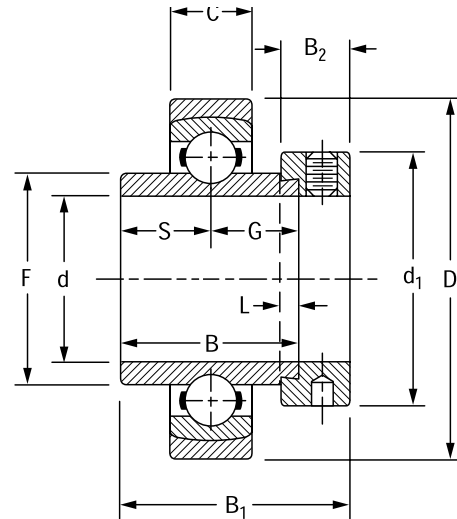

Bearing No.	Collar No.	Basic Outer-Ring Size	Shaft Dia. d	O.D. D	Ring Widths		S(G)	F	L	d ₁	B ₂	B ₁	Brg. and Collar Wt.		Static Load Rating C ₀	Extended Dynamic Load Rating C _E
					Inner B	Outer C							kg	lbs.		
SM1100KS	S1100K	205	1	57 2.2441	34.93 1 3/8	15 0.5910	17.46 1 1/16	33.83 1.332	4.0 5/32	38.10 1 1/2	13.50 17/32	44.10 1 47/64	0.263 0.58	0.58	7700 1730	15600 3450
SM1103KS	S1103K	206	1 3/16	68 2.6772	36.51 1 1/16	16 0.6300	18.30 23/32	39.12 1.540	4.0 5/32	44.40 1 3/4	15.90 5/8	48.40 1 29/32	0.418 0.92	0.92	11100 2500	21600 4800
SM1104KS	S1104K	207	1 1/4	79	37.70	17	18.85	46.13	4.0	54.40	17.46	51.20	0.726	1.60	11500	28500
SM1107KS	S1107K		1 7/16	3.1102	1 31/64	0.6690	0.742	1.816	5/32	2 1/8	11/16	2 1/64	0.658	1.45	3400	6400
SM1108KS	S1108KT	208	1 1/2	88 3.4646	42.86 1 11/16	18 0.7090	21.40 27/32	52.27 2.058	4.8 3/16	60.30 2 3/8	18.30 23/32	56.40 27/32	0.903 1.99	1.99	19600 4400	36000 8150
SM1115KS	S1115K	210	1 15/16	100 3.9370	49.21 1 15/16	20 0.7874	24.60 31/32	62.84 2.474	4.8 3/16	69.90 2 3/4	18.30 23/32	62.70 2 15/32	1.185 2.61	2.61	22700 5100	39000 8800
SM1203KS	S1203K	211	2 3/16	110 4.3307	55.56 2 3/16	21 0.8268	27.80 1 3/32	69.77 2.747	4.8 3/16	76.20 3	20.60 13/16	71.40 2 13/16	1.748 3.85	3.85	28500 6400	48000 10800
SM1207KS	S1207K	212	2 7/16	120 4.7244	61.91 2 7/16	22 0.8661	30.96 17/32	76.48 3.011	6.4 1/4	84.14 3 5/16	22.20 7/8	77.80 3 1/16	1.907 4.20	4.20	35600 8000	58500 13200
SM1211KS	S1211KT	214	2 11/16	140 5.5118	68.26 2 11/16	24 0.9449	34.13 1 11/32	86.92 3.422	6.4 1/4	96.84 3 13/16	23.81 15/16	79.40 3 3/8	2.974 6.55	6.55	43000 9650	69500 15600
SM1215KS	S1215K	215	2 15/16	145 5.7087	74.61 2 15/16	25 0.9843	37.30 1 15/32	91.92 3.619	6.4 1/4	101.60 4	23.81 15/16	92.08 3 5/8	3.541 7.80	7.80	43600 9800	68000 15300
SM1303KS	S1303K	216	3 3/16	155 6.1024	80.96 3 3/16	26 1.0236	40.48 1 19/32	98.40 3.874	6.4 1/4	111.13 4 3/8	25.40 1	100.01 3 15/16	4.150 9.14	9.14	53400 12000	80000 18000
SM1307KS	S1307K	217	3 7/16	165 6.4961	87.31 3 7/16	28 1.1024	43.66 1 23/32	104.83 4.127	6.4 1/4	112.71 4 7/16	25.40 1	106.36 4 3/16	4.690 10.33	10.33	61000 13700	93000 20800
SM1315WS ⁽¹⁾	S1315K	220	3 15/16	200 7.8740	100.01 3 15/16	34 1.3386	50.00 1 31/32	123.85 4.876	6.4 1/4	139.70 5 1/2	31.75 1 1/4	125.41 4 15/16	8.939 19.69	19.69	126900 28500	170000 38000

⁽¹⁾For applications where thrust load exceeds 60 percent of radial load, consult your Timken engineer.

NOTE: Bore tolerance: 1 in. – 2 3/16 in., nominal to +0.013 mm, +0.0005 in.
 2 1/4 in. – 3 3/16 in., nominal to +0.015 mm, +0.0006 in.
 3 1/4 in. – 3 15/16 in., nominal to +0.018 mm, +0.0007 in.

GY-KRRB SET SCREW INDUSTRIAL SERIES

- The Y series features super-finished raceways, grade-10 balls and antiback-out nylon-patch set screws; they are factory-prelubricated and relubricatable.
- The bearing includes R-seals with flared lips that firmly contact the ground O.D. of the inner ring. The inner ring provides a positive seal against dust, dirt and other contaminants, and effectively retains the lubricant.
- The Y-series set screw bearing has increased shaft support and extra-large grease capacity.
- The bearing is locked to the shaft by two set screws located 120 degrees apart which is ideal for reversing load applications.
- Premium Shaft Guarding Technology™ option reduces replacement time, provides shaft protection and prolongs the life of the shaft.

Suggested shaft tolerances:

1/2 in. – 1 15/16 in., nominal to -0.013 mm, -0.0005 in.;
 2 in. – 2 15/16 in., nominal to -0.025 mm, -0.0010 in.

To order bearing with Shaft Guarding Technology™, specify bearing number followed by “SGT”.

SHAFT GUARD TECHNOLOGY

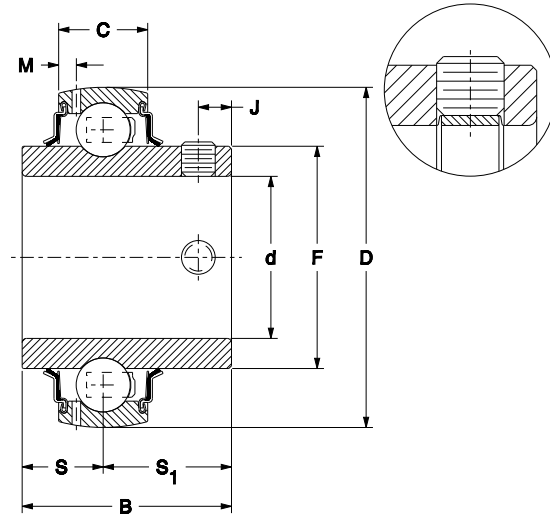

Bearing No.	Basic Outer-Ring Size	Shaft Dia. d	O.D. D	Ring Widths		S	S ₁	F	M	J	Set Screw Size	Static Load Rating C ₀	Extended Dynamic Load Rating C _E
				Inner B	Outer C								
		in. mm	mm in.	mm in.	mm in.	mm in.	mm in.	mm in.	mm in.	mm in.	mm in.	N lbs.	N lbs.
GY1008KRRB	203	1/2	40 1.5748	27.38 1.0780	12 0.472	11.50 0.453	15.88 0.6250	22.86 0.940	2.720 0.107	4.55 0.179	M5X.8 10 – 32	4760 1070	10600 2380
GY1009KRRB		9/16											
GY1010KRRB		5/8											
GY1011KRRB		11/16											
GYE17KRRB		17											
GY1012KRRB ⁽¹⁾	204	3/4	47 1.8504	30.96 ⁽²⁾ 1.2190	14 0.5500	12.70 0.500	18.26 ⁽²⁾ 0.7190	27.56 1.085	3.048 0.120	5.13 ⁽²⁾ 0.202	M5X.8 10 – 32	6583 1480	14300 3200
GYE20KRRB ⁽¹⁾		20											
GY1013KRRB	205	13/16	52 2.0472	34.11 ⁽²⁾ 1.3430	15 0.5910	14.27 0.562	19.91 ⁽²⁾ 0.7810	33.83 1.332	3.61 0.142	6.07 ⁽³⁾ 0.240	M6X1 1/4 – 28	7700 1730	15800 3490
GY1014KRRB ⁽¹⁾		7/8											
GY1015KRRB ⁽¹⁾		15/16											
GY1100KRRB ⁽¹⁾		1											
GYE25KRRB ⁽¹⁾		25											
GY1101KRRB	206	1 1/16	62 2.4409	38.10 ⁽⁴⁾ 1.5000	18 0.7090	15.88 0.625	22.22 ⁽⁴⁾ 0.8750	40.31 1.587	4.166 0.164	7.64 ⁽⁴⁾ 0.300	M6X1 1/4 – 28	11253 2500	21573 4850
GY1102KRRB ⁽¹⁾		1 1/8											
GY1103KRRB ⁽¹⁾		1 3/16											
GY1103KRRB3		1 1/4											
GYE30KRRB ⁽¹⁾		30											
GY1104KRRB ⁽¹⁾	207	1 1/4	72 2.8346	42.87 ⁽⁵⁾ 1.6880	19 0.7480	17.48 0.688	25.40 ⁽⁵⁾ 1.0000	46.82 1.844	3.68 0.145	7.870 ⁽⁵⁾ 0.309	M8X1.25 5/16 – 24	15300 3440	28500 6400
GY1105KRRB		1 5/16											
GY1106KRRB ⁽¹⁾		1 3/8											
GY1107KRRB ⁽¹⁾		1 7/16											
GYE35KRRB ⁽¹⁾		35											
GY1108KRRB ⁽¹⁾	208	1 1/2	80 3.1496	49.22 1.9380	21 0.8268	19.05 0.750	30.17 1.1880	52.27 2.058	3.188 0.125	8.00 0.315	M8X1.25 5/16 – 24	19840 4460	36164 8130
GY1109KRRB		1 9/16											
GYE40KRRB ⁽¹⁾		40											

⁽¹⁾ Shaft Guard Technology available

⁽²⁾ Inner Ring with SGT is wider by 0.737mm [0.029 in.]

⁽³⁾ Inner Ring with SGT is wider by 0.483mm [0.019 in.]

⁽⁴⁾ Inner Ring with SGT is wider by 1.016mm [0.040 in.]

⁽⁵⁾ Inner Ring with SGT is wider by 2.540mm [0.100 in.]

⁽⁶⁾ Inner Ring with SGT is wider by 1.143mm [0.045 in.]

NOTE: Bore tolerances: 1/2 in. – 2 3/16 in., nominal to +0.013 mm, +0.0005 in.
 2 1/4 in. – 3 15/16 in., nominal to +0.015 mm, +0.0006 in.

Continued on next page.

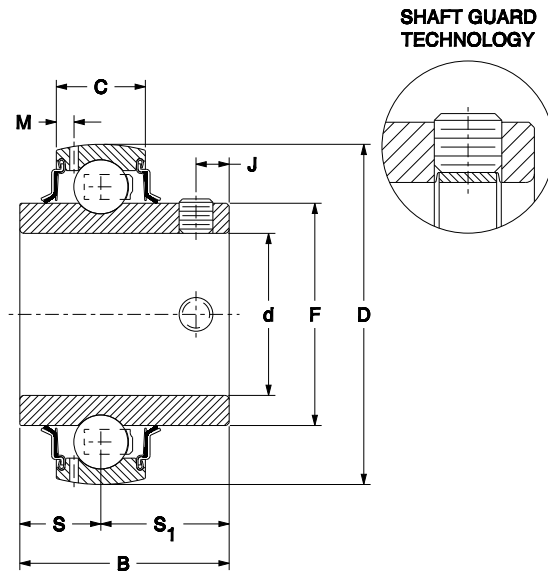

Continued from previous page.

Bearing No.	Basic Outer-Ring Size	Shaft Dia. d	O.D. D	Ring Widths		S	S ₁	F	M	J	Set Screw Size	Static Load Rating C ₀	Extended Dynamic Load Rating C _E
				Inner B	Outer C								
		in. mm	mm in.	mm in.	mm in.	mm in.	mm in.	mm in.	mm in.	mm in.	mm in.	N lbs.	N lbs.
GY1110KRRB ⁽¹⁾	209	1 5/8	85 3.3465	49.22 ⁽²⁾ 1.9830	22 0.8661	19.05 0.750	30.17 ⁽³⁾ 1.1880	57.91 2.280	3.7135 0.146	8.00 ⁽⁴⁾ 0.315	M8X1.25 5/16 – 24	20461 4600	36297 8160
GY1111KRRB ⁽¹⁾		1 11/16											
GY1112KRRB ⁽¹⁾		1 3/4											
GYE45KRRB ⁽¹⁾		45											
GY1113KRRB	210	1 13/16	90 3.5433	51.59 2.0310	22 0.8661	19.05 0.750	32.54 1.2810	62.84 2.474	3.975 0.156	10.00 0.394	M10X1.5 3/8 – 24	23175 5210	38877 8740
GY1114KRRB		1 7/8											
GY1115KRRB ⁽¹⁾		1 15/16											
GY1115KRRB3		2											
GYE50KRRB ⁽¹⁾		50											
GY1200KRRB ⁽¹⁾	211	2	100 3.9370	55.55 2.1870	24 0.9450	22.22 0.875	33.32 1.3120	69.77 2.747	4.902 0.193	10.00 0.394	M10X1.5 3/8 – 24	29224 6570	48000 10800
GY1201KRRB		2 1/16											
GY1202KRRB		2 1/8											
GY1203KRRB ⁽¹⁾		2 3/16											
GYE55KRRB ⁽¹⁾		55											
GY1204KRRB ⁽¹⁾	212	2 1/4	110 4.3307	65.07 2.5620	27 1.0630	25.40 1.000	39.67 1.5620	76.48 3.011	4.5085 0.177	10.00 0.394	M10X1.5 3/8 – 24	35941 8080	58271 13100
GY1205KRRB		2 5/16											
GY1206KRRB		2 3/8											
GY1207KRRB ⁽¹⁾		2 7/16											
GYE60KRRB ⁽¹⁾		60											
GY1211KRRB	214	2 11/16	125 4.9213	69.85 2.7500	28 1.1024	26.97 1.062	42.84 1.6870	86.92 3.422	4.876 0.1920	12.00 0.472	M12X1.75 7/16 – 20	43992 8500	68947 15500
GYE70KRRB		70											
GY1215KRRB	215	2 15/16	130 5.1181	77.80 3.0630	29 1.1420	33.32 1.312	44.45 1.7500	91.92 3.619	5.56 0.219	12 0.472	M12X1.75 7/16 – 20	44927 10100	68947 15500
GYE75KRRB		75											

⁽¹⁾ Shaft Guard Technology available

⁽²⁾ Inner Ring with SGT is wider by 0.737mm [0.029 in.]

⁽³⁾ Inner Ring with SGT is wider by 0.483mm [0.019 in.]

⁽⁴⁾ Inner Ring with SGT is wider by 1.016mm [0.040 in.]

⁽⁵⁾ Inner Ring with SGT is wider by 2.540mm [0.100 in.]

⁽⁶⁾ Inner Ring with SGT is wider by 1.143mm [0.045 in.]

NOTE: Bore tolerances: 1/2 in. – 2 3/16 in., nominal to +0.013 mm, +0.0005 in.
2 1/4 in. – 3 15/16 in., nominal to +0.015 mm, +0.0006 in.

ER INDUSTRIAL SERIES, RELUBRICATABLE TYPES

- Incorporates (optional) Shaft Guarding Technology, which reduces replacement time, provides shaft protection and prolongs shaft life.
- This bearing is designed for use in applications where low-starting torque and low-running torque are necessary.
- The ER-DD series is for applications where extremely low torque is required.
- Test results indicate an average of 95 percent reduction in start-up torque when using ER-DD instead of the standard ER bearing. Running torque is reduced up to 85–90 percent.

Suggested shaft tolerances:

- 1/2 in. – 1 15/16 in., nominal to -0.013 mm, -0.0005 in.;
- 2 in. – 3 7/16 in., nominal to -0.025 mm, -0.0010 in.

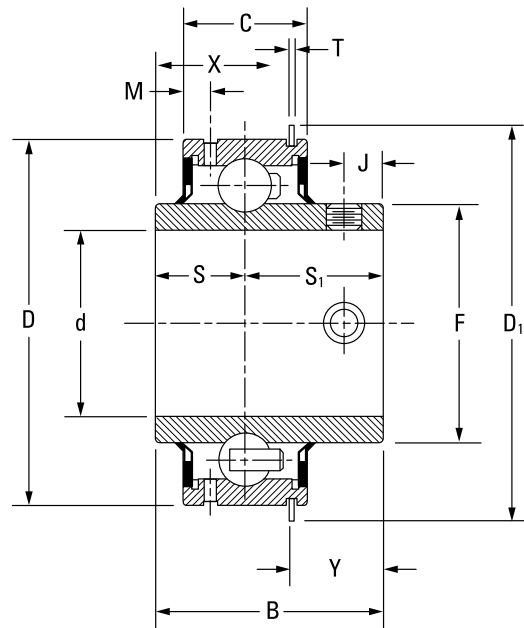

Bearing No.	Basic Outer-Ring Size	Shaft Dia. d	O.D. D	Ring Widths												Set Screw Size	Brg. Wt.		Static Load Rating C ₀	Extended Dynamic Load Rating C _E	
				Inner B	Outer C	S	S ₁	F	J	D ₁	Y	T	M	X	kg		lbs.	N			N
		in.	mm in.	mm in.	mm in.	mm in.	mm in.	mm in.	mm in.	mm in.	mm in.	mm in.	mm in.	mm in.	mm in.	mm in.	mm in.	kg	lbs.	N	N
ER08 ⁽¹⁾	204	1/2	47 1.850	30.963 1 7/32	15.817 5/8	12.700 1/2	18.263 64/89	27.546 1 5/64	5.131 13/64	52.400 2 6/95	16.612 1/16	1.067 3/64	3.861 5/32	14.351 9/16	M5X.8 10 - 32	0.190 0.167 0.141	0.42 0.37 0.31	6571.2 1480	14163.6 3190		
ER10 ⁽¹⁾		5/8																			
ER12 ⁽¹⁾⁽²⁾		3/4																			
ER14 ⁽¹⁾⁽²⁾	205	7/8	52 2.047	34.841 1 3/8	18.992 3/4	14.275 50/89	20.566 13/16	33.820 1 21/64	6.774 17/64	57.531 2 17/64	17.341 11/16	1.067 3/64	3.404 9/64	17.501 11/16	M6X1 1/4 - 28	0.218 0.195 0.181	0.480 0.43 0.40	7814.4 1760	15495.6 3490		
ER15 ⁽²⁾		15/16																			
ER16 ⁽¹⁾⁽²⁾		1																			
ER18 ⁽²⁾	206	1 1/8	62 2.441	39.116 1 35/64	22.167 7/8	15.875 5/8	23.241 59/64	40.297 1 37/64	8.636 11/32	67.285 2 41/64	18.948 3/4	1.651 1/16	5.563 7/32	20.168 51/64	M6X1 1/4 - 28	0.340 0.313	0.75 0.69	11233.2 2530	21534 4850		
ER19 ⁽²⁾		1 3/16																			
ER20 ⁽¹⁾⁽²⁾	207	1 1/4	72 2.834	45.415 1 25/32	23.754 15/16	17.475 11/16	27.940 1 7/64	46.825 1 27/32	10.363 13/32	78.105 3 5/64	22.301 7/8	1.651 1/16	5.563 7/32	23.114 29/32	M8X1.25 5/16 - 24	0.567 0.499 0.476	1.25 1.10 1.05	15273.6 3440	28416 6400		
ER22 ⁽¹⁾⁽²⁾		1 3/8																			
ER23 ⁽¹⁾⁽²⁾		1 7/16																			
ER24 ⁽¹⁾⁽²⁾	208	1 1/2	80 3.149	49.225 1 15/16	27.722 1 3/32	19.050 3/4	30.175 1 3/16	52.261 2 3/64	8.001 5/16	86.106 3 25/64	21.158 53/64	1.651 1/16	6.350 1/4	28.067 1 7/64	M8X1.25 5/16 - 24	0.671	1.48	19802.4 4460	36097.2 8130		
ER27 ⁽²⁾		1 11/16																			
ER28 ⁽¹⁾⁽²⁾	209	1 3/4	85 3.346	50.368 1 63/64	27.724 1 3/32	19.050 3/4	31.318 1 15/64	57.899 2 15/64	9.144 23/64	91.110 3 37/64	22.250 7/8	1.651 1/16	6.325 1/4	28.118 1 7/64	M8X1.25 5/16 - 24	0.735 0.690	1.62 1.52	20424 4600	36230.4 8160		
ER30		1 7/8																			
ER31 ⁽²⁾	210	1 15/16	90 3.543	51.587 2 1/32	28.517 1 1/8	19.050 3/4	32.537 1 9/32	62.827 2 15/32	10.008 25/64	96.088 3 25/32	24.282 31/32	2.413 3/32	7.061 9/32	27.305 1 5/64	M10X1.5 3/8 - 24	0.853 0.834	1.88 1.84	23132.4 5210	38805.6 8740		
ER31 ⁽²⁾		1 15/16																			

⁽¹⁾DD low-drag/low-torque version is available.

⁽²⁾Available with Shaft Guarding Technology modification.

NOTE: Bore tolerances: 1.1874 in. – 2.1874 in. nominal to +0.013 mm, +0.0005 in.
2.2500 in. – 3.1874 in. nominal to +0.015 mm, +0.0006 in.

Continued on next page.

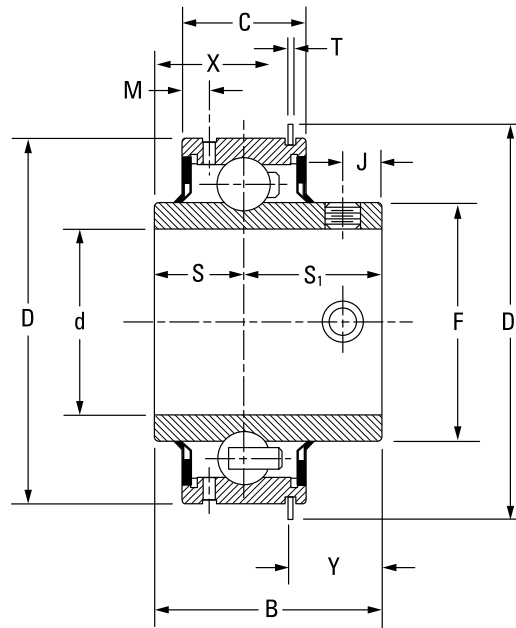

Continued from previous page.

Bearing No.	Basic Outer-Ring Size	Shaft Dia. d	O.D. D	Ring Widths										Set Screw Size	Brg. Wt.		Static Load Rating C ₀	Extended Dynamic Load Rating C _E		
				Inner B	Outer C	S	S ₁	F	J	D ₁	Y	T	M		X	kg			lbs.	N
		in.	mm in.	mm in.	mm in.	mm in.	mm in.	mm in.	mm in.	mm in.	mm in.	mm in.	mm in.	mm in.	mm in.	mm in.	kg	lbs.	N	N
ER32 ⁽¹⁾⁽²⁾ ER35 ⁽²⁾	211	2 3/16	100 3.9370	55.56 2 3/16	30.16 1 3/16	22.22 7/8	33.34 1 5/16	69.85 2 3/4	9.92 25/64	106.4 4 3/16	24.28 61/64	2.4 3/32	7.14 9/32	31.27 1 15/64	M10X1.5 3/8 - 24	1.300 1.084	2.87 2.39	29170.8 6570	47952 10800	
ER39 ⁽¹⁾⁽²⁾	212	2 7/16	110 4.331	65.09 2 9/16	31.75 1 1/4	25.4 1	39.69 1 9/16	76.60 3 1/64	9.92 25/64	116.3 4 37/64	28.24 1.11	2.4 3/32	6.75 1 7/64	36.83 1 29/64	M10X1.5 3/8 - 24	1.450 3.20	3.20	35875.2 8080	58164 13100	
ER47	215	2 15/16	130 5.1180	77.79 3 1/16	38.1 1 1/2	33.33 1 5/16	44.45 1 3/4	91.68 3 39/64	11.91 15/32	139.7 5 1/2	33.02 1.30	2.8 7/64	6.35 1/4	44.78 1 49/64	M12X1.75 7/16 - 20	2.210 4.88	4.88	44844 10100	68820 15500	
ER51	216	3 3/16	140 5.5110	77.79 3 1/16	42.86 1 11/16	28.58 1 1/8	49.21 1 15/16	98.43 3 7/8	13.49 17/32	149.6 5 57/64	35.32 1.39	2.8 7/64	11.11 7/16	42.47 1 43/64	M12X1.75 7/16 - 20	3.450 7.61	7.61	54168 12200	79476 17900	
ER55	217	3 7/16	150 5.905	85.72 3 3/8	49.21 1 15/16	34.16 1 11/32	51.57 2 1/32	104.84 4 1/8	11.91 7/16	159.5 6 1/4	34.53 1.36	2.8 7/64	11.02 7/16	51.21 2 1/64	M12X1.75 7/16 - 20	- -	- -	61716 13900	92796 20900	

⁽¹⁾DD low-drag/low-torque version is available.

⁽²⁾Available with Shaft Guarding Technology modification.

NOTE: Bore tolerances: 1.1874 in. – 2.1874 in. nominal to +0.013 mm, +0.0005 in.
2.2500 in. – 3.1874 in. nominal to +0.015 mm, +0.0006 in.

STANDARD SERIES

RA-RR, RA-RRB NON-RELUBRICATABLE TYPES

- These bearings are an extended inner-ring type with a self-locking collar.
- Due to the positive contact, the land-riding R-seal provides improved protection against harmful contaminants and retains lubricant under severe operating conditions.
- RA-RR series are factory-prelubricated and have cylindrical outside diameters.
- RA-RRB series have spherical outside diameters for use in housings with corresponding spherical inside surfaces to provide unrestricted initial alignment.

Suggested shaft tolerances:

- 1/2 in. – 1 15/16 in., nominal to -0.013 mm, -0.0005 in.;
- 2 in. – 2 3/16 in., nominal to -0.025 mm, -0.0010 in.

To order, specify bearing number followed by "+ COL".

Example: RA100RRB + COL.

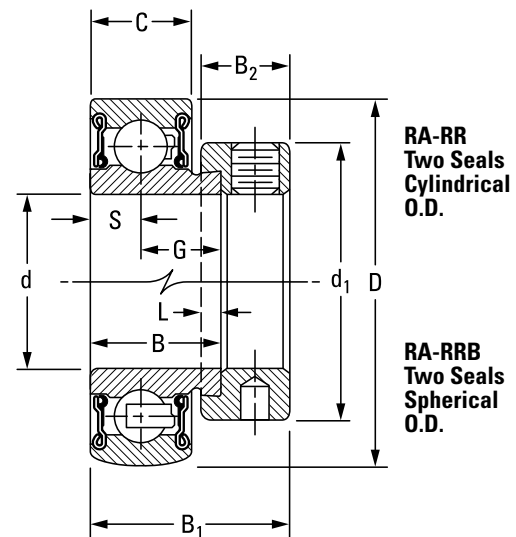

Bearing No.		Collar No.	Basic Outer-Ring Size	Shaft Dia. d	O.D. D	Ring Widths		S	G	L	d ₁	B ₂	B ₁	Brg. and Collar Wt.	Static Load Rating C ₀	Extended Dynamic Load Rating C _E	
Cylindrical O.D.	Spherical O.D.					Inner B	Outer C										
				in.	mm	mm	mm	mm	mm	mm	mm	mm	mm	kg	lbs.	N	N
				mm	in.	in.	in.	in.	in.	in.	in.	in.	in.	lbs.	lbs.	lbs.	lbs.
RA008RR	RA008RRB	S1008K	203	1/2	40 1.5748	19.05 0.750	13 0.512 ⁽¹⁾	6.50 0.256	12.55 0.494	4.0 5/32	28.60 1 1/8	13.5 17/32	28.6 1 1/8	0.154	0.34	4700 1060	10600 2360
RA009RR	RA009RRB	S1009K		9/16										0.145	0.32		
RA010RR	RA010RRB	S1010K		5/8										0.127	0.28		
RAE17RR	RAE17RRB	SE17K		17										0.127	0.28		
RA012RR	RA012RRB	S1012K	204	3/4	47 1.8504	21.44 0.844	15 0.591 ⁽²⁾	7.49 0.295	13.92 0.548	4.0 5/32	33.30 1 5/16	13.5 17/32	31.0 1 7/32	0.132	0.29	6200 1400	14300 3200
RAE20RR	RAE20RRB	SE20K		20										0.132	0.29		
RA013RR	RA013RRB	S1013K	205	13/16	52 2.0472	21.44 0.844	15 0.591	7.49 0.295	13.92 0.548	4.0 5/32	38.10 1 1/2	13.5 17/32	31.0 1 7/32	0.231	0.51	7700 1730	15800 3550
RA014RR	RA014RRB	S1014K		7/8										0.213	0.47		
RA015RR	RA015RRB	S1015K		15/16										0.200	0.44		
RA100RR	RA100RRB	S1100K		1										0.186	0.41		
RAE25RR	RAE25RRB	SE25K	25	0.186	0.41												
RA101RR	RA101RRB	S1101K	206	1 1/16	62 2.4409	23.82 0.938	18 0.709	8.99 0.354	14.81 0.583	4.0 5/32	44.10 1 47/64	15.9 5/8	35.7 1 13/32	0.349	0.77	11100 2500	21800 4900
RA102RR	RA102RRB	S1102K		1 1/8										0.327	0.72		
RA103RR	RA103RRB	S1103K		1 3/16										0.318	0.70		
RA103RR2	RA103RRB2	S1103K3		1 1/4										0.295	0.65		
RAE30RR	RAE30RRB	SE30K	30	0.318	0.70												
RA104RR	RA104RRB	S1104K	207	1 1/4	72 2.8346	25.40 1.000	19 0.748	9.50 0.374	15.90 0.626	4.0 5/32	54.40 2 1/8	17.1 43/64	38.9 1 17/32	0.562	1.24	15100 3400	28500 6400
RA105RR	RA105RRB	S1105K		1 5/16										0.540	1.19		
RA106RR	RA106RRB	S1106K		1 3/8										0.513	1.13		
RA107RR	RA107RRB	S1107K		1 7/16										0.476	1.05		
RAE35RR	RAE35RRB	SE35K	35	0.513	1.13												

⁽¹⁾Spherical O.D. outer-ring width is 12 mm (0.472 in.).

⁽²⁾Spherical O.D. outer-ring width is 14 mm (0.551 in.).

⁽³⁾Spherical O.D. outer-ring width is 21 mm (0.827 in.).

NOTE: Bore tolerance is nominal to +0.013 mm, +0.0005 in.

Continued on next page.

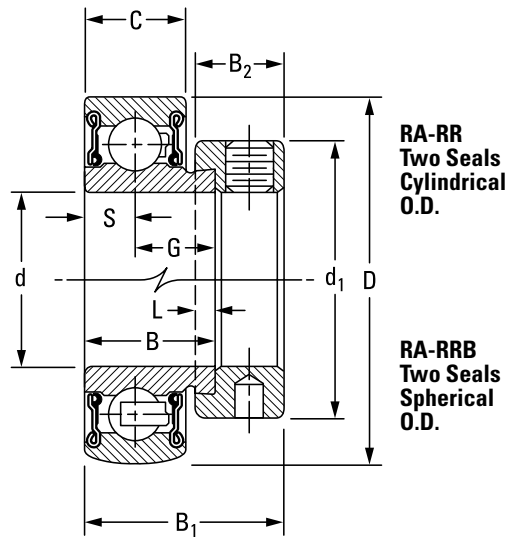

RA-RR
Two Seals
Cylindrical
O.D.

RA-RRB
Two Seals
Spherical
O.D.

Continued from previous page.

Bearing No.		Collar No.	Basic Outer-Ring Size	Shaft Dia.	O.D.	Ring Widths		S	G	L	d ₁	B ₂	B ₁	Brg. and Collar Wt.	Static Load Rating	Extended Dynamic Load Rating												
Cylindrical O.D.	Spherical O.D.					Inner	Outer																					
				d	D	B	C								C ₀	C _E												
				in.	mm	mm	mm	mm	mm	mm	mm	mm	mm	kg	lbs.	N	N											
RA108RR	RA108RRB	S1108K	208	1 1/2	80	30.18	22	11.00	19.18	4.8	60.30	18.3	43.7	0.694	1.53	19600	36000											
RA109RR	RA109RRB	S1109K		1 9/16										3.1496	1.188			0.866 ⁽³⁾	0.433	0.755	3/16	2 3/8	23/32	1 23/32	0.649	1.43	4400	8150
RAE40RR	RAE40RRB	SE40K		40																					0.649	1.43		
RA110RR	RA110RRB	S1110K	209	1 5/8	85	30.18	22	11.00	19.18	4.8	63.50	18.3	43.7	0.780	1.72	20000	36000											
RA111RR	RA111RRB	S1111K		1 11/16										3.3465	1.188			0.866	0.433	0.755	3/16	2 1/2	23/32	1 23/32	0.735	1.62	4500	8150
RA112RR	RA112RRB	S1112K		1 3/4																					0.680	1.50		
RAE45RR	RAE45RRB	SE45K		45										0.680	1.50													
RA113RR	RA113RRB	S1113K	210	1 13/16	90	30.18	22	11.00	19.18	4.8	69.90	18.3	43.7	0.880	1.94	22700	39200											
RA114RR	RA114RRB	S1114K		1 7/8										3.5433	1.188			0.866	0.433	0.755	3/16	2 3/4	23/32	1 23/32	0.830	1.83	5100	8800
RA115RR	RA115RRB	S1115K		1 15/16																					0.771	1.79		
RA115RR2	RA115RRB2	S1115K2		2										0.717	1.58													
RAE50RR	RAE50RRB	SE50K		50										0.771	1.79													
RA200RR	RA200RRB	S1200K	211	2	100	32.54	24	11.99	20.55	4.8	76.20	20.6	48.4	0.962	2.12	28500	48000											
RA201RR	RA201RRB	S1201K		2 1/16										3.9370	1.281			0.945	0.472	0.809	3/16	3	13/16	1 29/32	0.898	1.98	6400	10800
RA202RR	RA202RRB	S1202K		2 1/8																					0.857	1.89		
RA203RR	RA203RRB	S1203K		2 3/16																					0.807	1.78		
RAE55RR	RAE55RRB	SE55K		55																					0.807	1.78		

⁽¹⁾Spherical O.D. outer-ring width is 12 mm (0.472 in.).

⁽²⁾Spherical O.D. outer-ring width is 14 mm (0.551 in.).

⁽³⁾Spherical O.D. outer-ring width is 21 mm (0.827 in.).

NOTE: Bore tolerance is nominal to +0.013 mm, +0.0005 in.

GRA-RR, GRA-RRB RELUBRICATABLE TYPES

- GRA-RR-series bearings are the same as the RA-RR series and have a provision for relubrication.
- GRA-RR series have cylindrical outside diameters.
- GRA-RRB have spherical outside diameters

Suggested shaft tolerances:

- 1/2 in. – 1 15/16 in., nominal to -0.13 mm, -0.0005 in.;
- 2 in. – 2 3/16 in., nominal to -0.025 mm, -0.0010 in.

To order, specify bearing number followed by "+ COL".

Example: GRA100RRB + COL.

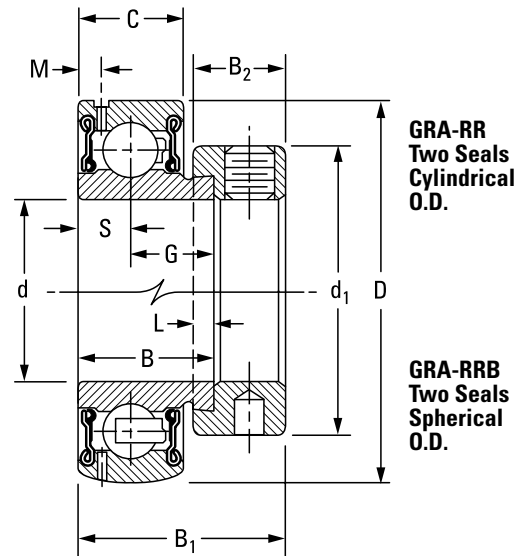

Bearing No.		Collar No.	Basic Outer-Ring Size	Shaft Dia. d	O.D. D	Ring Widths		S	G	L	d ₁	B ₂	M	B ₁	Brg. and Collar Wt. kg lbs.	Static Load Rating C ₀ N lbs.	Extended Dynamic Load Rating C _E N lbs.										
Cylindrical O.D.	Spherical O.D.					Inner B	Outer C																				
GRA008RR	GRA008RRB	S1008K	203	1/2	40	19.05	13	6.50	12.55	4.0	28.6	13.5	2.72	28.6	0.154	0.34	10600										
—	GRA009RRB	S1009K		9/16											1.5748	0.750		0.512 ⁽¹⁾	0.256	0.494	5/32	1 1/8	17/32	0.107	1 1/8	0.145	0.32
GRA010RR	GRA010RRB	S1010K		5/8											17	0.127		0.28	0.127	0.28							
GRAE17RR	GRAE17RRB	SE17K	204	3/4	47	21.44	15	7.49	13.92	4.0	33.3	13.5	3.05	31.0	0.132	0.29	14300										
GRA012RR	GRA012RRB	S1012K		20											1.8504	0.844		0.591 ⁽²⁾	0.295	0.548	5/32	1 5/16	17/32	0.120	1 7/32	0.132	0.29
GRAE20RR	GRAE20RRB	SE20K																									
—	GRA013RRB	S1013K	205	13/16	52	21.44	15	7.49	13.92	4.0	38.1	13.5	3.61	31.0	0.231	0.51	15800										
GRA014RR	GRA014RRB	S1014K		7/8											2.0472	0.844		0.591	0.295	0.548	5/32	1 1/2	17/32	0.142	1 7/32	0.213	0.47
—	GRA015RRB	S1015K		15/16																						0.200	0.44
GRA100RR	GRA100RRB	S1100K	206	1	62	23.83	18	8.99	14.81	4.0	44.1	15.9	4.17	35.7	0.186	0.41	21800										
GRAE25RR	GRAE25RRB	SE25K		25											0.186	0.41											
GRA101RR	GRA101RRB	S1101K		1 1/16																						0.349	0.77
GRA102RR	GRA102RRB	S1102K	207	1 1/8	72	25.40	19	9.50	15.90	4.0	54.0	17.1	3.68	38.9	0.327	0.72	28500										
GRA103RR	GRA103RRB	S1103K		1 3/16											2.4409	0.938		0.709	0.354	0.583	5/32	1 47/64	5/8	0.164	1 13/32	0.318	0.70
GRA103RR2	GRA103RRB2	S1103K3		1 1/4																						0.295	0.65
GRAE30RR	GRAE30RRB	SE30K	30											0.318	0.70												
GRA104RR	GRA104RRB	S1104K	207	1 1/4	72	25.40	19	9.50	15.90	4.0	54.0	17.1	3.68	38.9	0.562	1.24	28500										
—	GRA105RRB	S1105K		1 5/16											2.8346	1.000		0.748	0.374	0.626	5/32	2 1/8	43/64	0.145	1 17/32	0.540	1.19
—	GRA106RRB	S1106K		1 3/8																						0.513	1.13
—	GRA107RRB	S1107K	1 7/16											0.476	1.05	3400											
GRAE35RR	GRAE35RRB	SE35K	35											0.513	1.13	6400											

⁽¹⁾Spherical O.D. outer-ring width is 12 mm (0.472 in.).

⁽²⁾Spherical O.D. outer-ring width is 14 mm (0.551 in.).

⁽³⁾Spherical O.D. outer-ring width is 21 mm (0.827 in.).

NOTE: Bore tolerance is nominal to +0.013 mm, +0.0005 in.

Continued on next page.

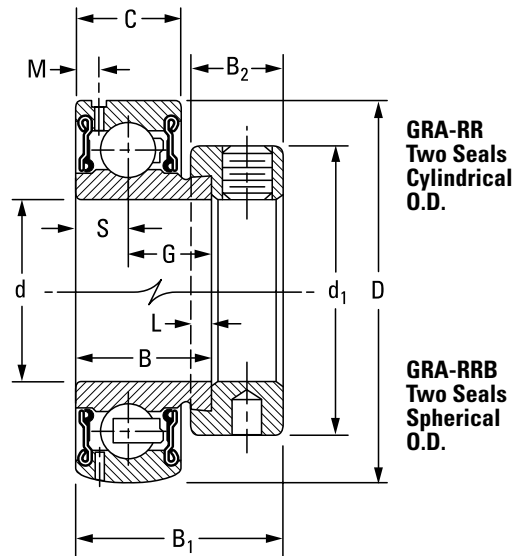

GRA-RR
Two Seals
Cylindrical
O.D.

GRA-RRB
Two Seals
Spherical
O.D.

Continued from previous page.

Bearing No.		Collar No.	Basic Outer-Ring Size	Shaft Dia. d	O.D. D	Ring Widths		S	G	L	d ₁	B ₂	M	B ₁	Brg. and Collar Wt. kg lbs.	Static Load Rating C ₀ N lbs.	Extended Dynamic Load Rating C _E N lbs.															
Cylindrical O.D.	Spherical O.D.					Inner B	Outer C																									
GRA108RR	GRA108RRB	S1108K	208	1 1/2	80 3.1496	30.18	22	11.00	19.18	4.8	60.3	18.3	4.17	43.7	0.694	1.53	19600	36000														
—	GRA109RRB	S1109K		1 9/16															1.188	0.866 ⁽³⁾	0.433	0.755	3/16	2 3/8	23/32	0.164	1 23/32	0.649	1.43	4400	8150	
GRAE40RR	GRAE40RRB	SE40K		40																									0.649	1.43		
—	GRA110RRB	S1110K	209	1 5/8	85 3.3465	30.18	22	11.00	19.18	4.8	63.5	18.3	4.55	43.7	0.780	1.72	20500	36300														
—	GRA111RRB	S1111K		1 11/16															1.188	0.866	0.433	0.755	3/16	2 1/2	23/32	0.179	1 23/32	0.735	1.62	4600	8160	
—	GRA112RRB	S1112K		1 3/4																									0.680	1.50		
—	GRAE45RRB	SE45K		45																									0.680	1.50		
—	GRA113RRB	S1113K	210	1 13/16	90 3.5433	30.18	22	11.00	19.18	4.8	69.9	18.3	4.44	43.7	0.880	1.94	22700	39200														
—	GRA114RRB	S1114K		1 7/8															1.188	0.866	0.433	0.755	3/16	2 3/4	23/32	0.175	1 23/32	0.830	1.83	5100	8800	
—	GRA115RRB	S1115K		1 15/16																									0.771	1.79		
—	GRA115RRB2	S1115K2		2																									0.717	1.58		
—	GRAE50RRB	SE50K		50																									0.771	1.79		
—	GRA200RRB	S1200K	211	2	100 3.9370	32.54	24	11.99	20.55	4.8	76.2	20.6	4.90	48.4	0.962	2.12	28500	48000														
—	GRA201RRB	S1201K		2 1/16															1.281	0.945	0.472	0.809	3/16	3	13/16	0.193	1 29/32	0.898	1.98	6400	10800	
—	GRA202RRB	S1202K		2 1/8																									0.857	1.89		
—	GRA203RRB	S1203K		2 3/16																									0.807	1.78		
—	GRAE55RRB	SE55K		55																									0.807	1.78		

⁽¹⁾Spherical O.D. outer-ring width is 12 mm (0.472 in.).

⁽²⁾Spherical O.D. outer-ring width is 14 mm (0.551 in.).

⁽³⁾Spherical O.D. outer-ring width is 21 mm (0.827 in.).

NOTE: Bore tolerance is nominal to +0.013 mm, +0.0005 in.

RA-DD NON-RELUBRICATABLE TYPES

- These bearings are an extended inner-ring type with a self-locking collar.
- The two non-contact grease shields retain lubricant, provide protection against harmful contaminants and offer improved high-speed, low-torque performance.
- RA-DD series are factory-prelubricated and have cylindrical outside diameters.

Suggested shaft tolerances:

1/2 in. – 1 15/16 in., nominal to -0.013 mm, -0.0005 in.;
 2 in. – 2 3/16 in., nominal to -0.025 mm, -0.0010 in.

To order, specify bearing number followed by "+ COL".

Example: RA100DD + COL.

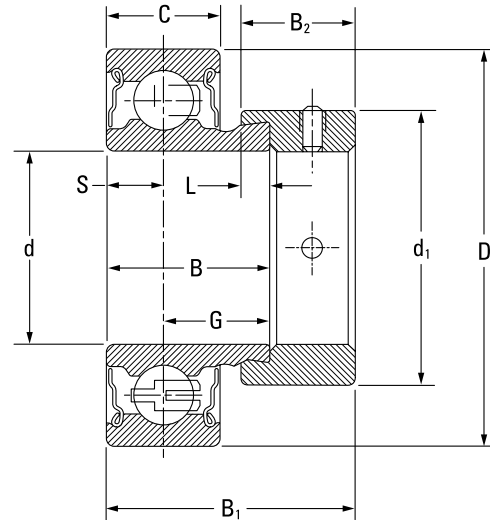

Bearing No.	Collar No.	Basic Outer-Ring Size	Shaft Dia. d	O.D. D	Ring Widths		S	G	L	d ₁	B ₂	B ₁	Static Load Rating C ₀	Extended Dynamic Load Rating C _E											
					Inner B	Outer C																			
			in. mm	mm in.	mm in.	mm in.	mm in.	mm in.	mm in.	mm in.	mm in.	mm in.	N lbs.	N lbs.											
RA008DD	S1008K	203	1/2	40.00	19.05	13.00	6.50	12.55	3.97	28.58	13.49	28.58	4400	10600											
RA009DD	S1009K		9/16												1.575	0.750	0.512	0.256	0.494	5/32	1 1/8	17/32	1 1/8	1000	2360
RA010DD ⁽¹⁾	S1010K		5/8												17										
RA012DD	S1012K	204	3/4	47.00	21.44	15.01	7.49	13.92	3.97	33.34	13.49	30.96	6200	14300											
RAE20DD	SE20K		20												1.850	0.844	0.591	0.295	0.548	5/32	1 5/16	17/32	1 7/32	1400	3200
RA013DD	S1013K	205	13/16	52.00	21.44	15.01	7.49	13.92	3.97	38.10	13.49	30.96	6950	15600											
RA014DD ⁽¹⁾	S1014K		7/8												2.047	0.844	0.591	0.295	0.548	5/32	1 1/2	17/32	1 7/32	1560	3450
RA015DD	S1015K		15/16												1										
RA100DD	S1100K		1												25										
RAE25DD	SE25K		25																						
RA101DD	S1101K	206	1 1/16	62.00	23.83	18.01	8.99	14.81	3.97	44.45	15.88	35.72	10000	21600											
RA102DD	S1102K		1 1/8												2.441	0.938	0.709	0.354	0.583	5/32	1 3/4	5/8	1 13/32	2280	4800
RA103DD ⁽¹⁾	S1103K		1 3/16																						
RA103DD2	S1103K3		1 1/4S												30										
RAE30DD	SE30K		30																						
RA104DD	S1104K	207	1 1/4	72.00	25.40	19.00	9.50	15.90	3.97	53.98	17.07	38.89	13700	28500											
RA105DD	S1105K		1 5/16												2.835	1.000	0.748	0.374	0.626	5/32	2 1/8	43/64	1 17/32	3050	6400
RA106DD	S1106K		1 3/8																						
RA107DD ⁽¹⁾	S1107K		1 7/16												35										
RAE35DD	SE35K		35																						
RA108DD ⁽¹⁾	S1108K	208	1 1/2	80.00	30.18	22.00	11.00	19.18	4.76	60.33	18.26	43.66	17600	36000											
RA109DD	S1109K		1 9/16												3.150	1.188	0.866	0.433	0.755	3/16	2 3/8	23/32	1 23/32	4000	8150
RAE40DD	SE40K		40																						

⁽¹⁾Popular sizes.

NOTE: Bore tolerance is nominal to +0.013 mm, +0.0005 in.

YA-RR, YA-RRB NON-RELUBRICATABLE TYPES

- These bearings are an extended inner-ring type and have specially designed set screws with unique thread form.
- The thread form in both series locks the bearing to the shaft so they are resistant to loosening during operation.
- A positive contact, land-riding R-seal provides improved protection against harmful contaminants in both series and retains lubricant under severe operating conditions.
- A 6/6 molded nylon retainer has proved effective under conditions of misalignment.
- YA-RR series has cylindrical outside diameters.
- YA-RRB series has spherical outside diameters for use in housings with corresponding spherical inside surfaces. This provides unrestricted initial self-alignment.

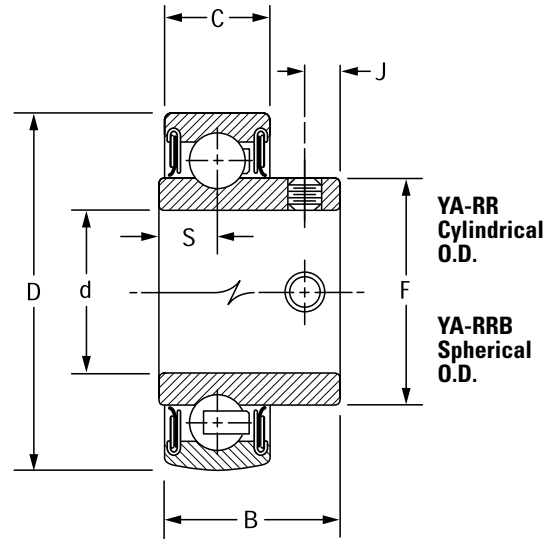

Suggested shaft tolerances:

- 1/2 in. – 1 15/16 in., nominal to -0.013 mm, -0.0005 in.;
- 2 in. – 2 3/16 in., nominal to -0.025 mm, -0.0010 in.

Bearing No.		Basic Outer-Ring Size	Shaft Dia. d	O.D. D	Ring Widths		S	F	J	Set Screw Size	Brg. Wt.	Static Load Rating C ₀	Extended Dynamic Load Rating C _E
Cylindrical O.D.	Spherical O.D.				Inner B	Outer C							
			in. mm	mm in.	mm in.	mm in.	mm in.	mm in.	mm in.	kg lbs.	N lbs.	N lbs.	
YA008RR	YA008RRB	203	1/2	40 1.5748	23.8 0.938	13 0.5120 ⁽¹⁾	7.95 0.313	24.6 31/32	4.75 0.187	M5X.8 10 – 32	0.09 0.19	4700 1060	10600 2360
YA010RR	YA010RRB		5/8										
YAE17RR	YAE17RRB		17										
YA012RR	YA012RRB	204	3/4	47 1.8504	27.0 1.063	15 0.5910 ⁽²⁾	8.86 0.349	29.0 1 1/64	6.02 0.237	M6X1 1/4 – 28	0.14 0.30	6200 1400	14300 3200
YAE20RR	YAE20RRB		20										
YA014RR	YA014RRB	205	7/8	52 2.0472	28.2 1.109	15 0.5910	8.84 0.348	33.7 1 21/64	6.35 0.250	M6X1 1/4 – 28	0.17 0.38	7700 1730	15800 3550
YA015RR	YA015RRB		15/16										
YA100RR	YA100RRB		1										
YAE25RR	YAE25RRB		25										
YA102RR	YA102RRB	206	1 1/8	62 2.4409	32.5 1.281	18 0.7090	9.65 0.380	40.1 1 37/64	7.87 0.310	M8X1.25 5/16 – 24 ⁽³⁾	0.26 0.58	11100 2500	21800 4900
YA103RR	YA103RRB		1 3/16										
YA103RR2	YA103RRB2		1 1/4										
YAE30RR	YAE30RRB		30										
YA104RR	YA104RRB	207	1 1/4	72 2.8346	36.5 1.444	19 0.7480	10.85 0.427	46.8 1 27/32	7.87 0.310	M8X1.25 5/16 – 24	0.42 0.93	15100 3400	28500 6400
YA106RR	YA106RRB		1 3/8										
YA107RR	YA107RRB		1 7/16										
YAE35RR	YAE35RRB		35										
YA108RR	YA108RRB	208	1 1/2	80 3.1496	39.3 1.538	22 0.8661 ⁽⁴⁾	11.63 0.458	52.4 2 1/16	7.87 0.310	M8X1.25 5/16 – 24	0.56 1.24	17600 4000	36000 8150
YAE40RR	YAE40RRB		40										
YA110RR	YA110RRB	209	1 5/8	85 3.3465	42.0 1.655	22 0.8861	13.46 0.530	57.9 2 9/32	7.87 0.310	M8X1.25 5/16 – 24	0.54 1.18	20500 4500	36300 8160
YA111RR	YA111RRB		1 11/16										
YA112RR	YA112RRB		1 3/4										
YAE45RR	YAE45RRB		45										
YA115RR	YA115RRB	210	1 15/16	90 3.5433	44.3 1.746	22 0.8661	13.46 0.530	62.7 2 15/32	9.02 0.355	M10X1.5 3/8 – 24	0.57 1.25	22700 5100	39200 8800
YA115RR2	YA115RRB2		2										
YAE50RR	YAE50RRB		50										
YA200RR	YA200RRB	211	2	100 3.9370	46.6 1.833	24 0.9449	14.60 0.575	69.8 2 3/4	9.02 0.355	M10X1.5 3/8 – 24	0.58 1.27	28500 6400	48000 10800
YA203RR	YA203RRB		2 3/16										
YAE55RR	YAE55RRB		55										

⁽¹⁾Spherical O.D. outer-ring width is 12 mm (0.4724 in.).
⁽²⁾Spherical O.D. outer-ring width is 14 mm (0.5512 in.).
⁽³⁾YA103RR2 and YA103RRB2 use 1/4 – 28 in. set screw.
⁽⁴⁾Spherical O.D. outer-ring width is 21 mm (0.8268 in.).
 NOTE: Bore tolerance is nominal to +0.013 mm, +0.0005 in.

GYA-RR, GYA-RRB RELUBRICATABLE TYPES

- GYA-RR-series bearings are dimensionally interchangeable with the YA-RR series.
- Both series have cylindrical outside diameters and can be used in standard cylindrical housings.
- GYA-RRB series have spherical outside diameters, providing unrestricted initial alignment. This series is used in housings with corresponding spherical inside surfaces.

Suggested shaft tolerances:

1/2 in. - 1 15/16 in., nominal to -0.013 mm, -0.0005 in.;
 2 in. - 2 3/16 in., nominal to -0.025 mm, -0.0010 in.

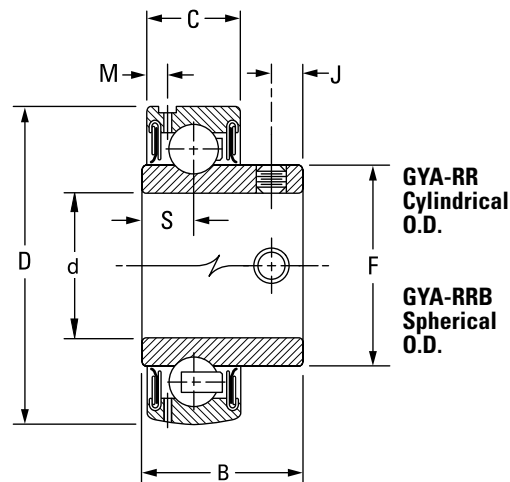

Bearing No.		Basic Outer-Ring Size	Shaft Dia. d	O.D. D	Ring Widths		S	F	M	J	Set Screw Size	Brg. Wt. kg lbs.	Static Load Rating C ₀ N lbs.	Extended Dynamic Load Rating C _E N lbs.
Cylindrical O.D.	Spherical O.D.				Inner B	Outer C								
			in. mm	mm in.	mm in.	mm in.	mm in.	mm in.	mm in.	mm in.				
GYA008RR	GYA008RRB	203	1/2	40 1.5748	23.8 0.938	12 0.4720	7.95 0.313	24.6 31/32	2.72 0.107	4.75 0.187	M5X.8 10 - 32	0.09 0.19	4700 1060	10600 2360
GYA010RR	GYA010RRB		5/8											
GYAE17RR	GYAE17RRB		17											
GYA012RR	GYA012RRB	204	3/4	47 1.8504	27.0 1.063	14 0.5510	8.86 0.349	29.0 1 9/64	3.05 0.120	6.02 0.237	M6X1 1/4 - 28	0.14 0.30	6200 1400	14300 3200
GYAE20RR	GYAE20RRB		20											
GYA014RR	GYA014RRB	205	7/8	52 2.0472	28.2 1.109	15 0.5910	8.84 0.348	33.7 1 21/64	3.61 0.142	6.35 0.250	M6X1 1/4 - 28	0.17 0.38	7700 1730	15800 3550
GYA015RR	GYA015RRB		15/16											
GYA100RR	GYA100RRB		1											
GYAE25RR	GYAE25RRB		25											
GYA102RR	GYA102RRB	206	1 1/8	62 2.4409	32.5 1.281	18 0.7090	9.65 0.380	40.1 1 37/64	4.17 0.164	7.87 0.310	M8X1.25 5/16 - 24 ⁽¹⁾	0.26 0.58	11100 2500	21800 4900
GYA103RR	GYA103RRB		1 3/16											
GYA103RR2	GYA103RRB2		1 1/4											
GYAE30RR	GYAE30RRB		30											
GYA104RR	GYA104RRB	207	1 1/4	72 2.8346	36.5 1.444	19 0.7480	10.85 0.427	46.8 1 27/32	3.68 0.145	7.87 0.310	M8X1.25 5/16 - 24	0.42 0.93	15100 3400	28500 6400
GYA106RR	GYA106RRB		1 3/8											
GYA107RR	GYA107RRB		1 7/16											
GYAE35RR	GYAE35RRB		35											
GYA108RR	GYA108RRB	208	1 1/2	80 3.1496	39.3 1.538	21 0.8270	11.63 0.458	52.4 2 1/16	4.17 0.164	7.87 0.310	M8X1.25 5/16 - 24	0.56 1.24	17600 4000	36000 8150
GYAE40RR	GYAE40RRB		40											
GYA110RR	GYA110RRB	209	1 5/8	85 3.3465	42 1.655	22 0.8661	13.46 0.530	57.9 2 9/32	4.54 0.179	7.87 0.310	M8X1.25 5/16 - 24	0.54 1.18	20000 4500	36000 8150
GYA111RR	GYA111RRB		1 11/16											
GYA112RR	GYA112RRB		1 3/4											
GYAE45RR	GYAE45RRB		45											
GYA115RR	GYA115RRB	210	1 15/16	90 3.5433	44.3 1.746	22 0.8661	13.46 0.530	62.7 2 15/32	4.44 0.175	9.02 0.355	M10X1.5 3/8 - 24	0.57 1.25	22700 5100	39200 8800
GYA115RR2	GYA115RRB2		2											
GYAE50RR	GYAE50RRB		50											
GYA200RR	GYA200RRB	211	2	100 3.9370	46.6 1.833	24 0.9449	14.60 0.575	69.8 2 3/4	4.90 0.193	9.02 0.355	M10X1.5 3/8 - 24	0.58 1.27	28500 6400	48000 10800
GYA203RR	GYA203RRB		2 3/16											
GYAE55RR	GYAE55RRB		55											

⁽¹⁾GYA103RR2 and GYA103RRB2 use 1/4 - 28 in. set screw.
 NOTE: Bore tolerance is nominal to +0.013 mm, +0.0005 in.

LIGHT SERIES

RAL-NPPB NON-RELUBRICATABLE TYPES

- RAL series are high-quality, compact, low-cost bearings and are intended for use in lightly loaded applications.
- RAL series are on extended inner-ring type with self-locking collars.
- Prelubricated RAL series incorporate the positive contact, land-riding R-seal. The seal has proved effective in the retention of lubricants and exclusion of foreign matter under extreme service conditions.
- RAL-NPPD-series bearings have spherical outside diameters providing unrestricted initial alignment.
- This bearing is used in housings with corresponding spherical inside surfaces.

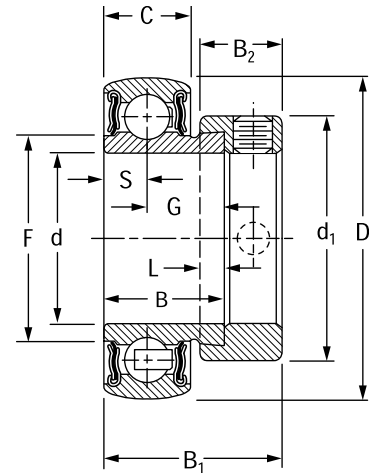

Suggested shaft tolerances:

1/2 in. – 1 1/4 in., nominal to -0.013 mm, -0.0005 in.

To order, specify bearing number followed by "+ COL".

Example: RAL100NPPB + COL.

Bearing No.	Collar No.	Basic Outer-Ring Size	Shaft Dia. d	O.D. D	Ring Widths		S	G	F	L	d ₁	B ₂	B ₁	Brg. and Collar Wt. kg lbs.	Static Load Rating C ₀ N lbs.	Extended Dynamic Load Rating C _E N lbs.	
					Inner B	Outer C											
RAL008NPPB ⁽¹⁾	LS008K	202	1/2	35 1.3780	15.88 5/8	11 0.433	5.502 0.2116	10.373 0.4084	20.07 0.790	4.0 5/32	25.4 1	11.1 7/16	23.8 15/16	0.06	0.13	3000 680	7500 1700
RAL009NPPB	LS009K		9/16														
RAL010NPPB ⁽¹⁾	LS010K		5/8														
RAL012NPPB ⁽¹⁾	LS012K	9104	3/4	42 1.6535	16.67 21/32	12 0.472	6.000 0.2362	10.663 0.4198	25.15 0.990	3.2 1/8	29.8 1 11/64	11.1 7/16	24.6 31/32	0.09	0.20	4400 1000	10400 2320
RAL013NPPB	LS013K	9105	13/16	47 1.8504	17.46 11/16	12 0.472	6.000 0.2362	11.476 0.4518	29.67 1.168	4.0 5/32	36.1 1 27/64	11.9 15/32	25.4 1	0.11	0.24	4900 1120	11000 2500
RAL014NPPB	LS014K		7/8														
RAL015NPPB	LS015K		15/16														
RAL100NPPB ⁽¹⁾	LS100K		1														
RAL101NPPB	LS101K	9106	1 1/16	55 2.1654	18.27 23/32	13 0.512	6.500 0.2559	11.755 0.4628	36.32 1.430	4.0 5/32	42.5 1 43/64	11.9 15/32	26.2 1 1/32	0.13	0.29	6950 1560	14600 3350
RAL102NPPB	LS102K		1 1/8														
RAL103NPPB	LS103K		1 3/16														
RAL103NPPB2 ⁽¹⁾	LS103K2		1 1/4														

⁽¹⁾Also available with cylindrical O.D. Delete suffix B.
NOTE: Bore tolerance is nominal to +0.013 mm, +0.0005 in.

MEDIUM SERIES

GYM-KRRB INSERTS SET SCREW LOCK

- This series is designed to offer extended bearing life despite demanding industrial environments.
- The insert features a full-width inner ring, providing extra support along the shaft.
- The extra support feature, coupled with a flexible nylon retainer, allows the inserts to operate for extended periods with undersized shafts or in misalignment conditions.
- The inserts are equipped with a three-piece seal, protecting against corrosion, contamination and fiber wrap.
- The inserts also include nylon-patch set screws, resisting set screw back-out and providing superior holding power in applications with severe vibration.

Suggested shaft tolerances:

- 1 in. – 1 15/16 in., nominal to -0.013 mm, -0.0005 in.;
- 2 in. – 3 in., nominal to -0.025 mm, -0.0010 in.

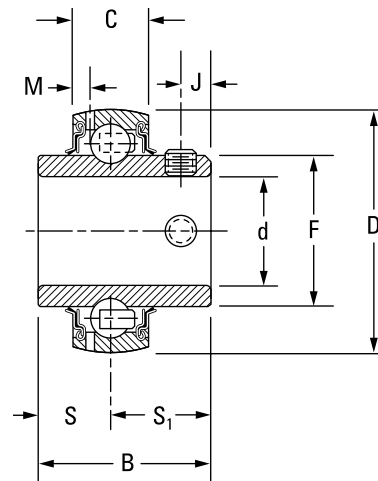

Bearing No.	Basic Outer-Ring Size	Shaft Dia.	O.D.	Ring Widths		S	S ₁	F	M	J	Set Screw Size	Brg. Wt.	Static Load Rating	Extended Dynamic Load Rating
				Inner	Outer									
Spherical O.D.		d	D	B	C								C ₀	C _E
		in.	mm in.	mm in.	mm in.	mm in.	mm in.	mm in.	mm in.	mm in.	mm in.	kg lbs.	N lbs.	N lbs.
GYM1100KRRB	206	1	62 2.4409	38.10 1.500	18 0.709	15.88 0.625	22.22 0.875	40.31 1.587	3.96 0.156	7.62 0.300	M6 x 1 1/4 – 28	0.427 0.94	11100 2500	21800 4900
GYM1103KRRB	207	1 3/16	72 2.8346	42.87 1.688	19 0.748	17.48 0.688	25.40 1.000	46.18 1.816	3.68 0.145	7.82 0.308	M8 x 1.25 5/16 – 24	0.704 1.55	15100 3400	28500 6400
GYM1107KRRB	208	1 7/16	80 3.1496	49.22 1.938	21 0.827	19.05 0.750	30.17 1.188	52.27 2.058	4.06 0.160	8.00 0.315	M8 x 1.25 5/16 – 24	0.817 1.80	19600 4400	36300 8150
GYM1108KRRB	209	1 1/2	85 3.3465	49.22 1.938	22 0.866	19.05 0.750	30.17 1.188	52.27 2.280	4.55 0.179	8.00 0.315	M8 x 1.25 5/16 – 24	0.885 1.95	20000 4500	36300 8150
GYM1111KRRB	210	1 11/16	90 3.5433	51.59 2.031	22 0.866	19.05 0.750	32.54 1.281	62.84 2.474	4.70 0.185	10.00 0.394	M10 x 1.5 3/8 – 24	1.271 2.80	22700 5100	39200 8800
GYM1112KRRB		1 3/4										1.203 2.65		
GYM1115KRRB	211	1 15/16	100 3.9370	55.55 2.187	24 0.945	22.22 0.875	33.32 1.312	69.77 2.747	5.00 0.197	10.00 0.394	M10 x 1.5 3/8 – 24	1.634 3.60	28500 6400	48100 10800
GY1200KRRB		2										1.498 3.30		
GYM1203KRRB	212	2 3/16	110 4.3307	65.07 2.562	27 1.063	25.40 1.000	39.67 1.562	76.48 3.011	5.13 0.202	10.00 0.394	M10 x 1.5 3/8 – 24	2.225 4.90	35600 8000	58800 13200
GY1204KRRB		2 1/4										1.952 4.30		
GYM1207KRRB	214	2 7/16	125 4.9213	69.85 2.750	28 1.102	26.97 1.062	42.84 1.687	76.48 3.422	5.08 0.200	12.00 0.472	M12 x 1.75 7/16 – 20	2.996 6.60	43000 9650	69500 15600
GYM1208KRRB		2 1/2										2.860 6.30		
GYM1211KRRB	215	2 11/16	130 5.1181	77.80 3.063	29 1.142	33.32 1.312	44.45 1.750	91.92 3.619	5.56 0.219	12.00 0.472	M12 x 1.75 7/16 – 20	3.042 6.70	43600 9800	69500 15600
GYM1215KRRB	216	2 15/16	140 5.5118	77.80 3.063	29 1.142	33.32 1.312	44.45 1.750	91.92 3.619	5.56 0.219	12.00 0.472	M12 x 1.75 7/16 – 20	3.087 6.80	53400 12000	80200 18000
GYM1300KRRB		3												

NOTE: Bore tolerance: 1/2 in. – 2 3/16 in., nominal to +0.013 mm, +0.0005 in.
2 1/4 in. – 3 in., nominal to +0.015 mm, +0.0006 in.

HEAVY SERIES

GN-KRRB RELUBRICATABLE TYPES

- The heavy series R-seal bearings are similar to the standard series and designed to withstand continuous, heavy or shock loads.
- This series has heavier-section 300-series bearings. They include a considerably thicker sealing member in the contact-type diaphragm seal.
- The design of the series ensures complete retention of the lubricant and positive exclusion of all contaminants.

Suggested shaft tolerances:

- 1 3/16 in. – 1 15/16 in., nominal to -0.013 mm, -0.0005 in.;
- 2 in. – 3 15/16 in., nominal to -0.025 mm, -0.0010 in.

To order, specify bearing number followed by "+ COL".

Example: GN303KRRB + COL.

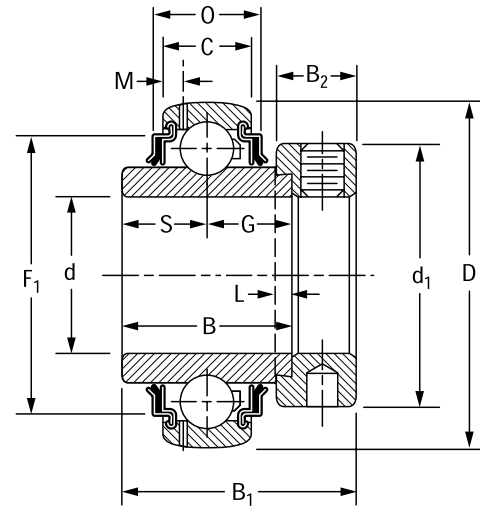

Bearing No.	Collar No.	Basic Outer-Ring Size	Shaft Dia. d	O.D. D	Ring Widths		S	G	L	d ₁	B ₂	M	B ₁	F ₁	O	Brg. and Collar Wt.		Static Load Rating C ₀	Extended Dynamic Load Rating C _E
					Inner B	Outer C										kg	lbs.		
GN103KRRB	SN103K	306	1 3/16	72 2.8346	36.51 1 7/16	20 0.787	17.5 11/16	19.1 3/4	4.0 5/32	49.2 1 15/16	17.5 11/16	3.61 0.142	50.0 1 31/32	60.17 2.369	23.50 0.925	0.553	1.22	15600 3550	33500 7500
GN104KRRB	SN104K	307	1 1/4	80 3.1496	38.10 1 1/2	22 0.866	18.3 23/32	19.8 25/32	4.0 5/32	55.6 2 3/16	17.5 11/16	3.96 0.156	51.6 2 1/32	67.01 2.638	27.00 1.063	0.762	1.68	20000 4500	40500 9150
GN105KRRB	SN105K		1 5/16													0.744	1.64		
GN106KRRB	SN106K		1 3/8													0.726	1.60		
GN107KRRB	SN107K		1 7/16													0.708	1.56		
GN108KRRB ⁽¹⁾	SN108K	308	1 1/2	90 3.5433	41.28 1 5/8	25 0.984	19.8 25/32	21.4 27/32	4.8 3/16	63.5 2 1/2	20.6 13/16	4.62 0.182	57.2 2 1/4	75.06 2.955	26.67 1.05	1.152	2.54	24500 5500	49000 11000
GN110KRRB	SN110K	309	1 5/8	100 3.9370	42.86 1 11/16	27 1.063	19.8 25/32	23.0 29/32	4.8 3/16	69.9 2 3/4	20.6 13/16	5.00 0.197	58.7 2 5/16	82.58 3.251	28.52 1.123	1.656	3.65	30000 6700	58500 13200
GN111KRRB	SN111K		1 11/16													1.456	3.21		
GN112KRRB ⁽¹⁾	SN112K		1 3/4													1.388	2.95		
GN114KRRB	SN114K	310	1 7/8	110 4.3307	49.21 1 15/16	29 1.142	24.6 31/32	24.6 31/32	4.8 3/16	75.8 2 63/64	22.2 7/8	5.36 0.211	66.7 2 5/8	82.87 3.654	30.86 1.215	1.973	4.35	35500 8000	68000 15300
GN115KRRB ⁽¹⁾	SN115K		1 15/16													1.905	4.20		
GN200KRRB	SN200K	311	2	120 4.7244	55.56 2 3/16	31 1.220	27.8 1 3/32	27.8 1 3/32	4.8 3/16	82.6 3 1/4	22.2 7/8	5.49 0.216	73.0 2 7/8	101.78 4.007	37.47 1.475	2.132	4.70	41500 9300	80000 18000
GN203KRRB	SN203K		2 3/16													2.368	5.22		

⁽¹⁾Also available with cylindrical O.D. Delete suffix B. Example: GN108KRR.
 NOTE: Bore tolerances: 1 3/16 in. – 2 3/16 in., nominal to +0.013 mm, +0.0005 in.;
 2 1/4 in. – 3 3/16 in., nominal to +0.015 mm, +0.0006 in.

Continued on next page.

GN-KRRB RELUBRICATABLE TYPES – continued

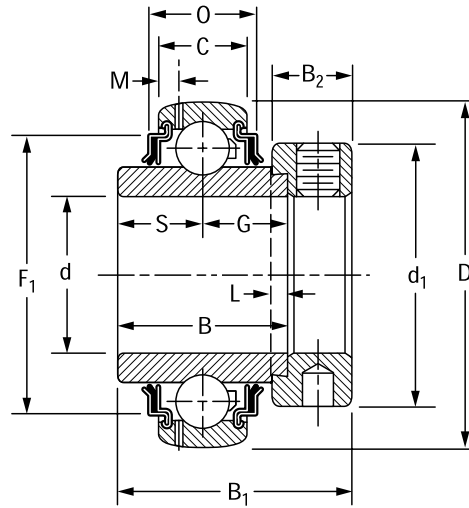

Continued from previous page.

Bearing No.	Collar No.	Basic Outer-Ring Size	Shaft Dia. d	O.D. D	Ring Widths		S	G	L	d ₁	B ₂	M	B ₁	F ₁	O	Brg. and Collar Wt.		Static Load Rating C ₀	Extended Dynamic Load Rating C _E
					Inner B	Outer C										kg	lbs.		
GN207KRRB	SN207K	312	2 7/16 in.	130 5.1181 mm in.	61.91 2 7/16 mm in.	33 1.299 mm in.	31.0 1 7/32 mm in.	31.0 1 7/32 mm in.	6.4 1/4 mm in.	88.9 3 1/2 mm in.	23.8 15/16 mm in.	5.84 0.230 mm in.	79.4 3 1/8 mm in.	108.52 4.312 mm in.	38.99 1.535 mm in.	2.839 6.26 kg lbs.	48000 10800 N lbs.	90000 20400 N lbs.	
GN211KRRB	SO211K	314	2 11/16 in.	150 5.9055 mm in.	68.26 2 11/16 mm in.	37 1.457 mm in.	34.1 1 11/32 mm in.	34.1 1 11/32 mm in.	6.4 1/4 mm in.	101.6 4 mm in.	27.0 1 1/16 mm in.	6.73 0.265 mm in.	88.9 3 1/2 mm in.	126.31 4.973 mm in.	44.96 1.770 mm in.	4.509 9.94 kg lbs.	63000 14300 N lbs.	116000 26000 N lbs.	
GN215KRRB	SN215K	315	2 15/16 in.	160 6.2992 mm in.	74.61 2 15/16 mm in.	39 1.535 mm in.	37.3 1 15/32 mm in.	37.3 1 15/32 mm in.	6.4 1/4 mm in.	112.7 4 7/16 mm in.	31.8 1 1/4 mm in.	6.48 0.255 mm in.	100.0 3 15/16 mm in.	133.02 5.273 mm in.	51.13 2.013 mm in.	5.634 12.42 kg lbs.	71000 16000 N lbs.	125000 28500 N lbs.	
GN303KRRB	SN303K	316	3 3/16 in.	170 6.6929 mm in.	80.96 3 3/16 mm in.	41 1.614 mm in.	40.5 1 19/32 mm in.	40.5 1 19/32 mm in.	6.4 1/4 mm in.	119.1 4 11/16 mm in.	31.8 1 1/4 mm in.	7.26 0.286 mm in.	106.4 4 3/16 mm in.	142.82 5.623 mm in.	51.05 2.010 mm in.	7.126 15.71 kg lbs.	80000 18000 N lbs.	137000 30500 N lbs.	
GN307KRRB	SN307K	318	3 7/16 in.	190 7.4803 mm in.	87.31 3 7/16 mm in.	45 1.772 mm in.	42.1 1 21/32 mm in.	42.1 1 21/32 mm in.	7.9 5/16 mm in.	133.4 5 1/4 mm in.	36.5 1 7/16 mm in.	8.18 0.322 mm in.	115.9 4 9/16 mm in.	161.37 6.353 mm in.	52.63 2.072 mm in.	9.190 20.26 kg lbs.	98000 22400 N lbs.	156000 33500 N lbs.	
GN315KRRB	SN315K	320	3 15/16 in.	215 8.4646 mm in.	100.01 3 15/16 mm in.	49 1.929 mm in.	50.0 1 31/32 mm in.	50.0 1 31/32 mm in.	7.9 5/16 mm in.	146.1 5 3/4 mm in.	36.5 1 7/16 mm in.	7.82 0.308 mm in.	129.6 5 1/16 mm in.	182.85 7.199 mm in.	59.36 2.337 mm in.	12.233 26.97 kg lbs.	132000 22900 N lbs.	193000 43000 N lbs.	

⁽¹⁾Also available with cylindrical O.D. Delete suffix B. Example: GN108KRR.
 NOTE: Bore tolerances: 1 3/16 in. – 2 3/16 in., nominal to +0.013 mm, +0.0005 in.;
 2 1/4 in. – 3 3/16 in., nominal to +0.015 mm, +0.0006 in.

GN-KLLB SPECIAL DUTY

- The GN-KLLB-series ball bearings are heavy and are similar in design to the standard LL (Mechani-Seal) wide-inner-ring ball bearings.
- The GN-KLLB series have heavier-section 300-series bearings.
- Unlike standard series, the seal in this heavy series is a three-piece construction and includes two fixed inner members and an external rotation slinger.

Suggested shaft tolerances:

- 1/8 in. – 1 15/16 in., nominal to -0.013 mm, -0.0005 in.;
- 2 in. – 2 15/16 in., nominal to -0.025 mm, -0.0010 in.

To order, specify bearing number followed by "+ COL".

Example: GN104KLLB + COL.

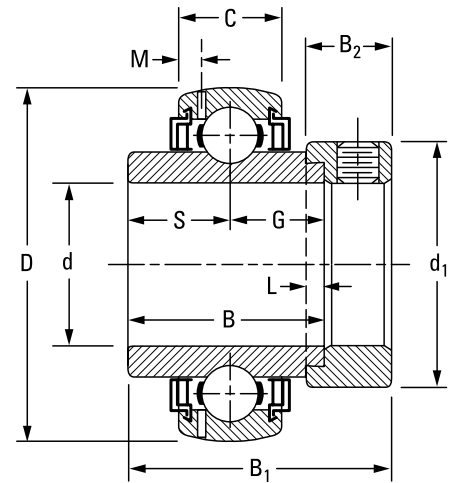

Bearing No.	Collar No.	Basic Outer-Ring Size	Shaft Dia. d	O.D. D	Ring Widths			S	G	L	d ₁	B ₂	M	B ₁	Brg. and Collar Wt. kg lbs.	Static Load Rating C ₀ N lbs.	Extended Dynamic Load Rating C _E N lbs.	
					Inner B	Outer C												
					mm in.	mm in.	mm in.	mm in.	mm in.	mm in.	mm in.	mm in.	mm in.	mm in.			N lbs.	N lbs.
GN102KLLB	SN102K	306	1 1/8	72	36.51	19	20	17.46	19.05	3.9	49.21	17.46	3.61	1.97	0.554	1.22	15800	33500
GN103KLLB	SN103K		1 3/16	2.8346	1 7/16	0.7480	0.7874	1 1/16	3/4	5/32	1 15/16	1 1/16	0.142	1 31/32	0.604	1.33	3550	7500
GN104KLLB	SN104K	307	1 1/4	80	38.10	21	22	18.30	19.84	3.9	55.60	17.46	3.96	51.59	0.649	1.43	21200	40500
GN106KLLB	SN106K		1 3/8	3.1496	1 1/2	0.8268	0.8661	23/32	25/32	5/32	2 3/16	1 1/16	0.156	2 1/32	0.699	1.54	4750	9150
GN107KLLB	SN107K		1 7/16												0.731	1.61		
GN108KLLB	SN108K	308	1 1/2	90	41.28	23	25	19.84	21.43	4.8	63.50	20.64	4.62	57.15	1.153	2.54	26100	49000
				3.5433	1 5/8	0.9055	0.9843	25/32	27/32	3/16	2 1/2	13/16	0.182	2 1/4			5850	11000
GN111KLLB	SN111K	309	1 11/16	100	42.86	25	27	19.84	23.02	4.8	69.85	20.64	4.80	58.74	1.457	3.21	31600	58500
GN112KLLB	SN112K		1 3/4	3.9370	1 11/16	0.9843	1.0630	25/32	29/32	3/16	2 3/4	13/16	0.189	2 5/16	1.657	3.65	7100	13200
GN115KLLB	SN115K	310	1 15/16	110	50.00	27	29	24.60	24.60	4.8	76.20	22.23	5.16	66.68	1.907	4.20	37900	68000
				4.3307	1 31/32	1.0630	1.1417	31/32	31/32	3/16	3	7/8	0.203	2 5/8			8500	15300
GN203KLLB	SN203K	311	2 3/16	120	55.56	29	31	27.80	29.37	4.8	82.55	22.23	5.49	73.02	2.370	5.22	43600	80000
				4.7244	2 3/16	1.1417	1.2205	1 3/32	1 5/32	3/16	3 1/4	7/8	0.216	2 7/8			9800	18000
GN207KLLB	SN207K	312	2 7/16	130	61.91	31	33	30.96	30.96	6.4	88.90	23.80	5.84	79.38	2.841	6.26	51700	90000
				5.1181	2 7/16	1.2205	1.2992	1 7/32	1 7/32	1/4	3 1/2	15/16	0.230	3 1/8			11600	20400
GN211KLLB	SN211K	314	2 11/16	150	68.26	35	37	34.13	34.13	6.4	101.60	26.99	6.73	88.90	4.512	9.94	66800	116000
				5.9055	2 11/16	1.3780	1.4567	1 11/32	1 11/32	1/4	4	1 1/16	0.265	3 1/2			15000	26000
GN215KLLB	SN215K	315	2 15/16	160	74.61	—	39	37.30	37.30	6.4	112.71	31.75	6.48	100.01	5.638	12.42	75700	125000
				6.2992	2 15/16	—	1.5354	1 15/32	1 15/32	1/4	4 7/16	1 1/4	0.255	3 15/16			17000	28500

NOTE: Bore tolerance: 1/2 in. – 2 3/16 in., nominal to +0.013 mm, +0.0005 in.
 2 7/16 in. – 2 15/16 in., nominal to +0.015 mm, +0.0006 in.

WIDE-INNER-RING BALL BEARINGS

HEAVY SERIES • SMN A AND B TYPES/MUOA-B INSERTS

SMN A AND B TYPES/MUOA-B INSERTS⁽¹⁾

- SMN series types A and B have the same ring tolerances and corner radii as equivalent 300-series single-row radial ball bearings.
- Type A has cylindrical outside diameters; type B has spherical outside diameters. The letter B appears on the outer ring only.
- The bearings are not prelubricated.

Suggested shaft tolerances:

5/8 in. – 1 15/16 in., nominal to -0.013 mm, -0.0005 in.;
 2 3/16 in. – 3 15/16 in., nominal to -0.025 mm, -0.0010 in.
 For larger sizes, contact your Timken engineer.

To order, specify bearing number followed by "+ COL".

Example: SMN102K + COL.

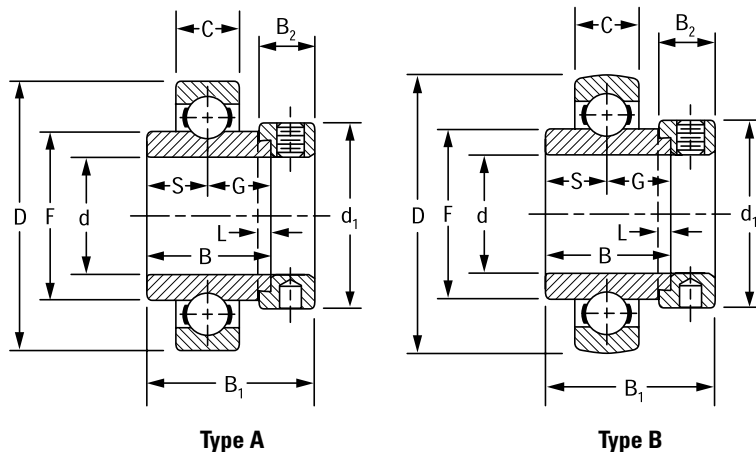

Bearing No.		Collar No.	Basic Outer-Ring Size	Shaft Dia.	O.D.	Ring Widths									Brg. and Collar Wt.		Static Load Rating	Extended Dynamic Load Rating		
A Type ⁽²⁾	B Type					Inner	Outer	S	G	F	L	d ₁	B ₂	B ₁	kg	lbs.			C ₀	C _e
				d	D	B	C	mm in.	mm in.	mm in.	mm in.	mm in.	mm in.	mm in.	mm in.	mm in.	kg	lbs.	N	N
SMN010K	SMN010KB	SN010K	303	5/8	47	34.13	14	17.07	17.07	25.93	4.00	34.93	15.88	46.05	0.240	0.53	6550	15000		
SMN011K	SMN011KB	SN011K		11/16	1.8504	1 11/32	0.5512	43/64	43/64	1.021	5/32	1 3/8	5/8	1 13/16	0.218	0.48	1460	3350		
SMN012K	SMN012KB	SN012K	304	3/4	52	34.93	15	15.90	19.05	29.24	4.00	36.51	15.88	46.83	0.227	0.50	7800	17600		
					2.0472	1 3/8	0.5906	5/8	3/4	1.151	5/32	1 7/16	5/8	1 27/32	0.1760	0.4000	1760	4000		
SMN013K	SMN013KB	SN013K	305	13/16	62	34.93	17	16.67	18.26	36.50	4.00	42.86	15.88	46.83	0.445	0.98	12200	26000		
SMN014K	SMN014KB	SN014K		7/8											2.4409	1 3/8			0.6693	21/32
SMN015K	SMN015KB	SN015K		15/16											0.413	0.91				
SMN100K	SMN100KB	SN100K		1											0.404	0.86				
SMN101K	SMN101KB	SN101K	306	1 1/16	72	36.51	19	17.46	19.05	43.23	4.00	49.21	17.46	50.00	0.608	1.34	15600	33500		
SMN102K	SMN102KB	SN102K		1 1/8											2.8346	1 7/16			0.7480	11/16
SMN103K	SMN103KB	SN103K		1 3/16											0.567	1.25				
SMN104K	SMN104KB	SN104K	307	1 1/4	80	38.10	21	18.26	19.84	48.95	4.00	55.60	17.46	51.59	0.803	1.77	21200	40500		
SMN105K	SMN105KB	SN105K		1 15/16											3.1496	1 1/2			0.8268	23/32
SMN106K	SMN106KB	SN106K		1 3/8											0.726	1.60				
SMN107K	SMN107KB	SN107K		1 7/16											0.721	1.56				
SMN108K	SMN108KB	SN108K	308	1 1/2	90	41.28	23	19.84	21.43	55.50	4.80	63.50	20.64	57.15	1.089	2.40	26100	49000		
SMN109K	SMN109KB	SN109K		1 9/16											3.5433	1 5/8			0.9055	25/32
SMN110K	SMN110KB	SN110K		1 5/8											1.433	3.16				
SMN111K	SMN111KB	SN111K	309	1 11/16	100	42.86	25	19.84	23.02	62.05	4.80	69.90	20.64	58.74	1.361	3.00	31600	58500		
SMN112K	SMN112KB	SN112K		1 3/4											3.9370	1 11/16			0.9843	25/32
SMN113K	SMN113KB	SN113K		1 13/16											1.896	4.18				
SMN114K	SMN114KB	SN114K	310	1 7/8	110	49.21	27	24.61	24.61	68.78	4.80	76.20	22.20	66.68	1.805	3.98	37900	68000		
SMN115K	SMN115KB	SN115K		1 15/16											4.3307	1 15/16			1.0630	31/32

⁽¹⁾See page 162.

⁽²⁾Order as MUOA assembly suggested.

⁽³⁾For applications where thrust load exceeds 60 percent of radial load, consult your Timken engineer.

NOTE: Bore tolerance: 5/8 in. – 2 3/16 in., nominal to +0.013 mm, +0.0005 in.
 3 1/4 in. – 4 3/16 in., nominal to +0.018 mm, +0.0007 in.
 4 7/16 in. – 4 15/16 in., nominal to +0.020 mm, +0.0008 in.

Continued on next page.

WIDE-INNER-RING BALL BEARINGS

HEAVY SERIES • SMN A AND B TYPES/MUOA-B INSERTS

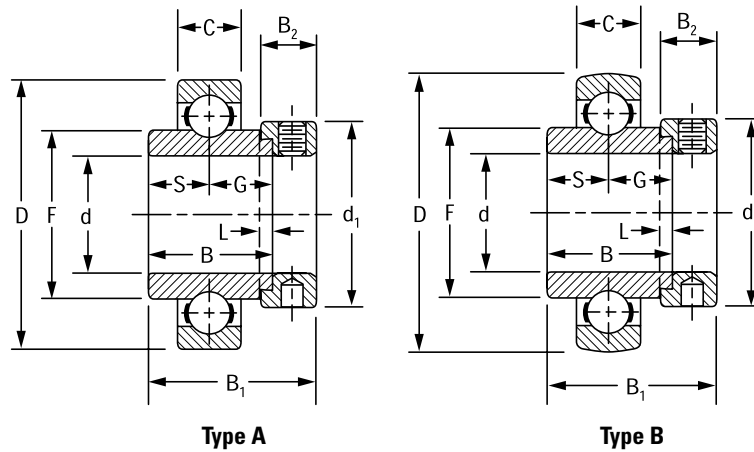

Continued from previous page.

Bearing No.		Collar No.	Basic Outer-Ring Size	Shaft Dia.	O.D.	Ring Widths		S	G	F	L	d ₁	B ₂	B ₁	Brg. and Collar Wt.		Static Load Rating	Extended Dynamic Load Rating
A Type ⁽²⁾	B Type					Inner	Outer								kg	lbs.		
				d	D	B	C	mm	mm	mm	mm	mm	mm	mm	kg	lbs.	N	N
				in.	mm	mm	mm	in.	in.	in.	in.	in.	in.	in.	kg	lbs.	N	N
SMN200K	SMN200KB	SN200K	311	2											2.413	5.32		
SMN201K	SMN201KB	SN201K		2 1/16	120	55.56	29	27.78	27.78	75.01	4.80	82.55	22.20	73.03	2.395	5.28	43600	80000
SMN202K	SMN202KB	SN202K		2 1/8	4.7244	2 3/16	1.1417	1 3/32	1 3/32	2.953	3/16	3 1/4	7/8	2 7/8	2.331	5.14	9800	18000
SMN203K	SMN203KB	SN203K		2 3/16											2.209	4.87		
SMN204K	SMN204KB	SN204K	312W	2 1/4											3.084	6.80		
SMN205K	SMN205KB	SN205K		2 9/16	130	61.91	31	31.00	31.00	81.53	6.40	88.90	23.81	79.38	3.012	6.64	51480	89800
SMN206K	SMN206KB	SN206K		2 3/8	5.1181	2 7/16	1.2205	1 7/32	1 7/32	3.210	1/4	3 1/2	1 5/16	3 1/8	2.908	6.41	11700	20400
SMN207K	SMN207KB	SN207K		2 7/16											2.812	6.20		
SMN211K	SMN211KB	SO211K		314	2 11/16	150	2.69	35	34.13	34.13	94.78	6.40	101.60	26.99	92.08	4.205	9.27	66800
				5.9055	2 11/16	1.3780	1 11/32	1 11/32	3.731	1/4	4	1 1/16	3 5/8			15000	26000	
SMN215K	SMN215KB	SN215K	315	2 15/16	160	74.61	37	37.31	37.31	100.38	6.40	112.71	31.75	100.01	5.856	12.91	75700	125000
				6.2992	2 15/16	1.4567	1 15/32	1 15/32	3.952	1/4	4 7/16	1 1/4	3 15/16			17000	28500	
SMN303K	SMN303KB	SN303K	316	3 3/16	170	80.96	39	40.48	40.48	106.91	6.40	119.06	31.75	106.36	6.704	14.78	86000	137000
				6.6929	3 3/16	1.5354	1 19/32	1 19/32	4.209	1/4	4 11/16	1 1/4	4 3/16			19300	30500	
SMN307K	SMN307KB	SN307K	318	3 7/16	190	87.31	43	43.66	43.66	120.12	7.94	133.35	36.51	115.89	9.984	22.01	106900	156000
				7.4803	3 7/16	1.6929	1 23/32	1 23/32	4.729	5/16	5 1/4	1 7/16	4 9/16			24000	35500	
SM0311W-BR ⁽³⁾	SM0311WB-BR ⁽³⁾	SO311K	319	3 11/16	200	93.66	45	38.89	54.77	126.67	7.94	139.70	36.51	122.24	11.090	24.45	173700	224000
				7.8740	3 11/16	1.7717	1 17/32	2 5/32	4.987	5/16	5 1/2	1 7/16	4 13/16			39000	50000	
SMN315K	SMN315KB	SN315K	320	3 15/16	215	100.01	47	50.00	50.00	134.77	7.94	146.05	36.51	128.59	13.068	28.81	140300	193000
				8.4646	3 15/16	1.8504	1 31/32	1 31/32	5.306	5/16	5 3/4	1 7/16	5 1/16			31500	43000	
SMN403W-BR ⁽³⁾	SMN403WB-BR	SN403K	321	4 3/16	225	104.78	49	48.42	56.36	141.22	7.94	157.16	42.86	139.70	15.508	34.19	202700	250000
				8.8583	4 3/16	1.9291	1 29/32	2 7/32	5.560	5/16	6 3/16	1 11/16	5 1/2			45500	56000	
SMN407W-BR ⁽³⁾	SMN407WB-BR ⁽³⁾	SN407K	322	4 7/16	240	106.36	50	49.21	57.15	142.75	7.94	165.10	42.86	141.29	19.051	42.00	245000	285100
				9.4488	4 7/16	1.9685	1 15/16	2 1/4	5.920	5/16	6 1/2	1 11/16	5 9/16			55000	64000	
SMN415W-BR ⁽³⁾	SMN415WB-BR ⁽³⁾	SN415K	326	4 15/16	280	106.36	59	53.98	61.91	176.56	7.94	206.38	42.86	150.81	29.660	65.39	327400	347400
				11.0236	4 3/16	2.3228	2 1/8	2 7/16	6.951	5/16	8 1/8	1 11/16	5 15/16			73500	78000	

⁽¹⁾ See page 162.

⁽²⁾ Order as MUOA assembly suggested.

⁽³⁾ For applications where thrust load exceeds 60 percent of radial load, consult your Timken engineer.

NOTE: Bore tolerance: 5/8 in. – 2 3/16 in., nominal to +0.013 mm, +0.0005 in.

3 1/4 in. – 4 3/16 in., nominal to +0.018 mm, +0.0007 in.

4 7/16 in. – 4 15/16 in., nominal to +0.020 mm, +0.0008 in.

SMN-S SERIES

- The SMN-S heavy-series construction permits its inner assembly to swivel in the outer aligning ring.
- Unrestricted self-alignment is achieved, allowing the inner ring to become square and true with the shaft and assembly.
- The external S-ring is uniquely ground and closely matched to its respective outer-bearing ring so that the S-ring of one bearing will not fit the outer ring of another bearing.
- This bearing has the basic 300-series load capacities.
- The bearings are not prelubricated.

Suggested shaft tolerances:

1 3/16 in. – 1 15/16 in., nominal to -0.013 mm, -0.0005 in.;
 2 in. – 3 15/16 in., nominal to -0.025 mm, -0.0010 in.
 Greater than 3 15/16 in., consult your Timken engineer.

To order, specify bearing number followed by "+ COL".

Example: SMN103KS + COL.

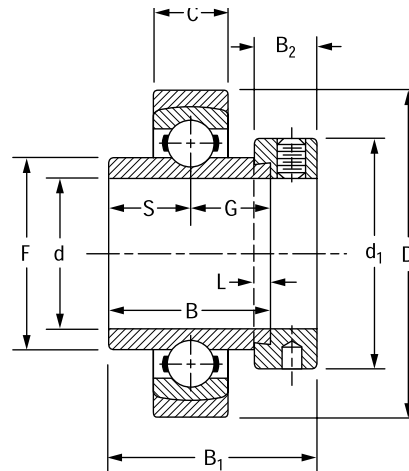

Bearing No.	Collar No.	Basic Outer-Ring Size	Shaft Dia. d	O.D. D	Ring Widths		S	G	F	L	d ₁	B ₂	B ₁	Brg. and Collar Wt.		Static Load Rating C ₀	Extended Dynamic Load Rating C _E
					Inner B	Outer C								kg	lbs.		
SMN103KS	SN103K	306	1 3/16	80 3.1496	36.51 1 7/16	19 0.7480	17.50 11/16	19.10 3/4	43.23 1.702	4.0 5/32	49.20 1 15/16	17.50 1 1/16	50.00 1 31/32	0.654 1.44	15600 3550	33500 7550	
SMN107KS	SN107K	307	1 7/16	88 3.4646	38.10 1 1/2	21 0.8268	18.30 23/32	19.80 25/32	48.95 1.927	4.0 5/32	55.60 2 3/16	17.50 1 1/16	51.60 2 1/32	0.849 1.87	21200 4750	40500 9150	
SMN108KS	SN108KT	308	1 1/2	100 3.9370	41.28 1 5/8	23 0.9055	19.80 25/32	21.40 27/32	55.50 2.185	4.8 3/16	63.50 2 1/2	20.60 1 3/16	57.20 2 1/4	1.344 2.96	26100 5850	49000 11000	
SMN111KS	SN111K	309	1 11/16	110 4.3307	42.86 1 11/16	25 0.9843	19.80 25/32	23.00 29/32	62.05 2.443	4.8 3/16	69.90 2 3/4	20.60 1 3/16	58.70 2 5/16	1.693 3.73	31600 7100	58500 13200	
SMN115KS	SN115K	310	1 15/16	120 4.7244	49.21 1 15/16	27 1.0630	24.60 31/32	24.60 31/32	68.78 2.708	4.8 3/16	76.20 3	22.20 7/8	66.70 2 5/8	2.147 4.73	37900 8500	68000 15300	
SMN203KS	SN203K	311	2 3/16	130 5.1181	55.56 2 3/16	29 1.1417	27.80 1 1/32	27.80 1 3/32	75.01 2.953	4.8 3/16	82.60 3 1/4	22.20 7/8	73.00 2 7/8	2.769 6.10	43600 9800	80000 18000	
SMN207KS	SN207K	312	2 7/16	145 5.7087	61.91 2 7/16	31 1.2205	31.00 1 7/32	31.00 1 7/32	81.53 3.210	6.4 1/4	88.90 3 1/2	23.80 15/16	79.40 3 1/8	3.405 7.50	51700 11600	90000 20400	
SMN211KS	SO211K	314	2 11/16	165 6.4961	68.26 2 11/16	35 1.3780	34.10 1 11/32	34.10 1 11/32	94.70 3.731	6.4 1/4	101.60 4	27.00 1 1/16	92.10 3 5/8	5.185 11.42	66800 15000	116000 26000	
SMN215KS	SN215K	315	2 15/16	175 6.8898	74.61 2 15/16	37 1.4567	37.30 1 15/32	37.30 1 15/32	100.38 3.952	6.4 1/4	112.70 4 7/16	31.80 1 1/4	100.00 3 15/16	6.456 14.22	75700 17000	125000 28500	
SMN303KS	SN303K	316	3 3/16	190 7.4803	80.96 3 3/16	39 1.5354	40.50 1 19/32	40.50 1 19/32	106.91 4.209	6.4 1/4	119.10 4 11/16	31.80 1 1/4	106.40 4 3/16	8.040 17.71	86000 19300	137000 30500	
SMN307KS	SN307K	318	3 7/16	210 8.2677	87.31 3 7/16	43 1.6929	43.70 1 23/32	43.70 1 23/32	120.12 4.729	7.9 5/16	133.40 5 1/4	36.50 1 7/16	115.90 4 9/16	1.790 25.97	106900 24000	156000 35500	
SMO311WS-BR	SO311K	319	3 11/16	220 8.6608	93.66 3 11/16	45 1.7680	38.89 1 17/32	54.77 2 5/32	126.53 4.982	7.9 5/16	139.70 5 1/2	36.51 1 7/16	122.24 4 13/16	16.300 33.00	166000 37500	224000 50000	
SMN315KS	SN315K	320	3 15/16	235 9.2520	100.01 3 15/16	47 1.8504	50.00 1 31/32	50.00 1 31/32	134.77 5.306	7.9 5/16	146.00 5 3/4	36.50 1 7/16	128.60 5 1/16	15.822 34.85	140300 31500	193000 43000	
SMN407WS-BR ⁽¹⁾	SN407K	322	4 7/16	265 10.4331	106.36 4 3/16	50 1.9685	49.20 1 15/16	57.20 2 1/4	150.37 5.920	7.9 5/16	168.30 6 1/2	42.90 1 11/16	141.30 5 9/16	21.465 47.28	245000 55000	280000 63000	
SMN415WS-BR ⁽¹⁾	SN415K	326	4 15/16	300 11.8110	115.89 4 9/16	59 2.3228	54.00 2 1/8	61.90 2 7/16	176.56 6.951	7.9 5/16	206.40 8 1/8	42.90 1 11/16	150.80 5 15/16	33.773 74.39	327400 73500	345000 78000	

⁽¹⁾For applications where thrust load exceeds 60 percent of radial load, consult your Timken engineer.

NOTE: Bore tolerance: 1 5/16 in. – 2 3/16 in., nominal to +0.013 mm, +0.0005 in.
 2 1/4 in. – 3 3/16 in., nominal to +0.015 mm, +0.0006 in.
 3 1/4 in. – 4 3/16 in., nominal to +0.018 mm, +0.0007 in.
 4 7/16 in. – 4 15/16 in., nominal to +0.020 mm, +0.0008 in.

MOUNTED BALL BEARINGS

Timken® Fafnir® mounted bearings are available in a wide variety of types and sizes to accommodate a complete range of operating conditions.

- **Sizes:** 12.7 mm – 125.4 mm (1/2 in. – 4 15/16 in.). Size range is dependent upon duty series.
- **Industries and applications:** Agriculture, food processing, conveyors, fans and blowers.
- **Features:** Most popular design features cast-iron housing. Other material options include malleable iron, polymer, pressed-steel or rubber.
- **Benefits:** Combines bearing, housing, seal and locking system into one device for easy installation. Operates even when the shaft is not perfectly aligned with the mounting surface.

Nomenclature.....	67
Introduction.....	68

CAST-IRON MOUNTED BEARINGS

RAK, TAK, LAK Industrial Series	71
YAK Industrial-Series Set Screw Units	73
VAK Standard Series.....	74
SAK Standard Series.....	75
RAS, TAS, LAS Industrial Series	76
RASC Industrial-Series Concentric Collar.....	78
YAS Industrial-Series Set Screw Units	79
VAS Standard Series.....	80
SAS Standard Series.....	81
RAKH Industrial Series	82
RAKHL Expansion Series	83
YASM Medium-Duty Series Set Screw Lock	84
STB Series.....	85
YTB Series.....	86
VTB Series.....	87
RAO, LAO Heavy Series	88
RSA, LSA Industrial Series.....	89
RSOA, LSAO Heavy Series.....	91
SAL Industrial Series, Fixed and Floating Types.....	92
SAOL Heavy Series, Fixed and Floating Types	93
DRNR Industrial Series.....	95

CAST-IRON FLANGED UNITS

RCJ, TCJ, LCJ Industrial Series.....	96
RCJC Industrial-Series Concentric Collar.....	98

YCJ Industrial Set Screw Series.....	99
VCJ Standard Series.....	101
SCJ Standard Series.....	102
RCJO, LCJO Heavy Series	103
YCJM Medium-Duty Series Set Screw Lock	104
YCJTM Medium-Duty Series Set Screw Lock	105
RCJT, TCJT, LCJT Industrial Series.....	106
RCJTC Industrial-Series Concentric Collar.....	107
VCJT Standard Series.....	108
YCJT Industrial Set Screw Series.....	109
SCJT Standard Series.....	110
FLCT Standard Series.....	111
RFC Industrial Piloted-Series Concentric Collar.....	112
RC Series.....	113

MALLEABLE-IRON FLANGED UNITS

GVFD, GVFDR Relubricatable Series –	
VFD, VFDR Non-Relubricatable Series.....	114
GRFD, GRFDR Relubricatable Series –	
RFD, RFDR Non-Relubricatable Series.....	115



MALLEABLE-IRON FLANGED UNITS – *continued*

GVFTD, GVFTDR Relubricatable Series –	
VFTD, VFTDR Non-Relubricatable Series	115
GRFTD, GRFTDR Relubricatable Series –	
RFTD, RFTDR Non-Relubricatable Series	117

PRESSED-STEEL MOUNTED BEARINGS

PBS Series	118
PB Series – RPB Series	119

PRESSED-STEEL FLANGED UNITS

VFMS Series	121
LFST Series	122

PRESSED-STEEL FLANGETTE UNITS

RR Flangette Unit	123
RA Flangette Unit	125
RAT, RRT Two-Bolt Flangette Units	127
RATR, RRTR Triangle Flangette Units	129
GRA, GRR Relubricatable Flangette Units	131

RUBBER CARTRIDGES

RCSM, RCR, CR Series	133
RABR HVAC Special Series	134

TAKE-UP UNITS

NLTU Series Side-Mounted, Pressed-Steel	135
TU Series Top-Mounted, Cast-Iron	136
RTU Industrial Series	137
YTU Industrial Series	138
VTU Standard Series	139
TTU Industrial Series	140

TIMKEN® FAFNIR® SURVIVOR® PS SERIES

KAK/S Series	142
KJC Series	143
KCJT and KTB Series	144

TIMKEN® FAFNIR® SURVIVOR® PT SERIES

YAK/S Series	146
YJC Series	147
YJCT Series	148
YTB and YFB Series	149
RAK/S Series	150
RCJ Series	151
RCJT and RTB Series	152

TIMKEN® FAFNIR® SURVIVOR® NT SERIES

YJC and YJCT Series	154
RAK/S Series	155
RCJ Series	156
RCJT Series	157
RTU Series	158

MISCELLANEOUS MOUNTED BEARINGS

Idler Pulley Units	159
Roller Chain Idler Sprockets	161

REPLACEMENT BEARINGS

Mounted Bearing Replacement Chart	162
-----------------------------------	-----

MACHINE UNITS

TIMKEN® FAFNIR® MOUNTED BALL BEARINGS SAFETY

END CAPS MAKE WORKPLACE PROTECTION A SNAP	165
---	-----

NOMENCLATURE

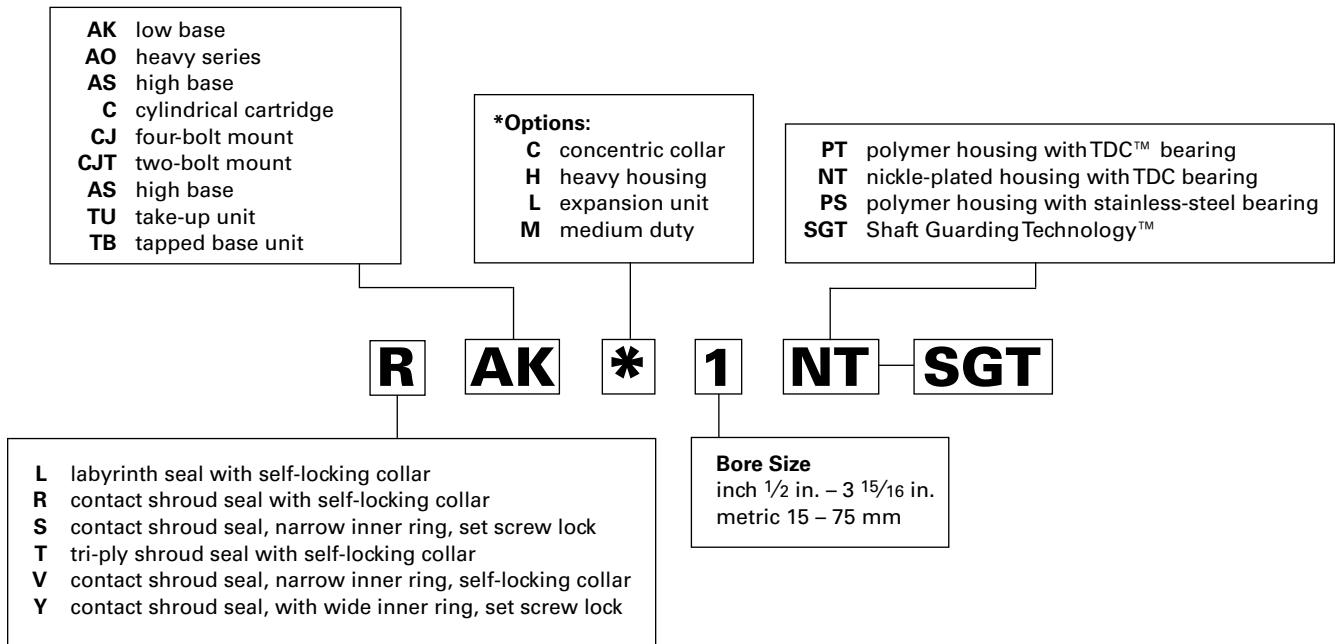

Fig. 19. Wide-inner-ring mounted ball bearing

INTRODUCTION

Mounted ball bearings are available in a wide variety of types and sizes to accommodate a complete range of operating conditions.

These units generally have cast-iron housings and mount on straight shafts with a slip fit. The self-locking collar and the set screw inner-bearing designs make mounting easier. Many of the set screw units include Shaft Guarding Technology™ (see page 33). Bolt holes in housings take standard bolts to attach units to machinery frames. Several series are available with the concentric locking collar. Most units have a self-aligning feature.

Units incorporating prelubricated wide-inner-ring ball bearings may be furnished without grease fittings.

Several basic types of mounted bearings are available:

- Pillow blocks also known as mounted bearings.
- Flanged cartridges.
- Flangette units.
- Cylindrical cartridges.
- Take-up units.

The choice is determined by application and mounting requirements. Within the basic type selected, variations are available for specific load factors, shaft sizes, mounting surface dimensions, base-to-shaft centerline heights and lubrication requirements.

PILLOW BLOCKS

Pillow blocks, the most commonly used type of mounted units, provide shaft support where the mounting surface is parallel to the shaft axis (fig. 20). The bolt holes are usually slotted for easy adjustment during mounting.

Pillow blocks come in a variety of configurations.

- Narrow series (V and S) are lightweight, yet structurally designed to support bearing load.
- Premium width series (R and Y) are three times stronger for rougher environments. They're available in two styles that fit typical applications.
- Pressed steel and rubber pillow blocks are available for light-duty applications.



Fig. 20. Pillow block.

FLANGED CARTRIDGES

Flanged cartridges are used where a shaft passes through the machine frame at a right angle (fig. 21). A four-bolt mounting is the most common; however, where the mounting area is restricted, three- and two-bolt versions are available. A piloted flanged cartridge provides additional mounting accuracy and support.



Fig. 21. Flanged cartridge.

Flanged cartridges are supplied in both standard and heavy-duty series. Iron- and rubber-flanged cartridges also are available.

A complete line of flangette units or pressed-steel flanged cartridges provides an economical solution for light-duty applications. Two-, three- and four-bolt mountings are available along with a relubricatable version.

CYLINDRICAL CARTRIDGES

Cylindrical cartridges, like flanged cartridges, provide shaft support where the shaft axis is perpendicular to and passing through a machined housing that is generally very thick (fig. 22). The outside diameter of the cylindrical cartridges permits mounting with a press fit into a straight, through-bored housing.

Cylindrical cartridges have a machined spherical bearing seat to provide initial shaft alignment in standard-duty applications. Synthetic, conductive rubber cylindrical cartridges are available for applications where low-cost, light-duty, low-noise operation is essential.



Fig. 22. Cylindrical cartridge.



Fig. 23. Take-up unit.

TAKE-UP UNITS

Take-up units are used where shaft adjustment and belt-tightening devices are required, such as conveyor applications (fig. 23). Frames for take-up units provide for either side or top mounting.

Take-up units are available in cast-iron for standard-duty applications and pressed steel for economical, light-duty applications.

FEATURES AND BENEFITS OF TIMKEN® FAFNIR® MOUNTED BALL BEARINGS



NOTE

Failure to follow the mounting/dismounting instructions of your equipment supplier can cause damage to the shaft, leading to premature failure of the equipment.

www.timken.com/warning/WIR

TIMKEN SELF-LOCKING COLLAR INSTALLATION

Most Timken Fafnir mounted bearings come equipped with the self-locking collar to facilitate the mounting of wide-inner-ring ball bearings. This self-locking collar eliminates the need for locknuts, washers, shoulders, sleeves and adapters.

The locking collar has a counterbored recess made purposely eccentric to the bore. The collar recess and the end of the bearing inner ring with which it engages are both machined so that they act as mating cams when on the shaft.

When the collar is engaged to the inner ring, it grips the shaft tightly with a positive binding action that increases with use. No adjustments of any kind are necessary.

CONCENTRIC COLLAR

For simplified installation of Timken Fafnir mounted bearings equipped with concentric-collar bearings, the collar is normally assembled to the wide inner ring for shipment. Slip the complete unit on the shaft following steps 1 and 2 (table 22) described for the self-locking collar procedure, and tighten both set screws.

TIMKEN FAFNIR SET SCREW LOCKING BEARING

Steps 1 and 2 (table 22) can be repeated from the self-locking collar installation above. To lock the set screw bearing, simply tighten each inner ring set screw to the suggested torque listed by shaft size. See table 21.

TABLE 21. SET SCREW LOCKING GUIDE.

Shaft Size		SUGGESTED
in.	mm	Torque in. - lbs.
1/2 – 11/16	17	35
3/4 – 1	20 – 25	80
1 1/16 – 1 3/4	30 – 45	155
1 13/16 – 2 3/16	50 – 55	275

It may be necessary to rotate the shaft to provide an easy access of the set screw wrench to the set screws. To disassemble, loosen the set screws.

TABLE 22. SELF-LOCKING COLLAR INSTALLATION



1. Slip the shaft through the pillow block or other Timken Fafnir mounted bearing incorporating the wide-inner-ring ball bearing. Be certain the bearing is aligned in position along the shaft to eliminate any possibility of cramping loads.



2. Fasten the unit securely to the base using the proper bolt size.



3. Place the self-locking collar on the shaft with its cam adjacent to the cam on the end of the bearing's inner ring. The eccentric recessed cam will slide over and engage the corresponding cam on the bearing inner ring. Turn the collar in the direction of shaft rotation.



4. Using a lightweight hammer and a drift pin inserted in the drift-pin hole, tap lightly in the direction of shaft rotation to positively engage the collar. The wide inner ring is now locked to the shaft.



5. As a final step, fully tighten the set screw. It exerts a wedging action to hold the collar always in the engaged position, even under shock load. This design will operate effectively after the cams are tightly locked and in most cases, with no set screws at all.

CAST-IRON MOUNTED BEARINGS

RAK, TAK, LAK INDUSTRIAL SERIES

RAK, TAK and LAK pillow blocks are suggested for industrial applications where normal loads are encountered.

- Heavier than our standard block with solid, flat feet for increased strength.
- Compact, one-piece housing can be mounted in any position.
- Pillow blocks self-align at mounting with the spherical outside diameter of the bearing fitting into the corresponding spherical housing seat.
- Pre-lubricated and ready for immediate installation.
- Grease fitting for relubrication.
- Self-locking collars supplied with all units.
- RAK pillow block is equipped with G-KRRB (R-seal) wide-inner-ring ball bearings, the TAK with G-KPPB (tri-ply seal) wide-inner-ring ball bearings and the LAK with the G-KLLB (Mechani-seal) wide-inner-ring ball bearings.
- Contact a Timken engineer to discuss highly corrosive applications (food processing, chemical exposure) where Timken thin-dense chrome-coated bearings can be utilized.

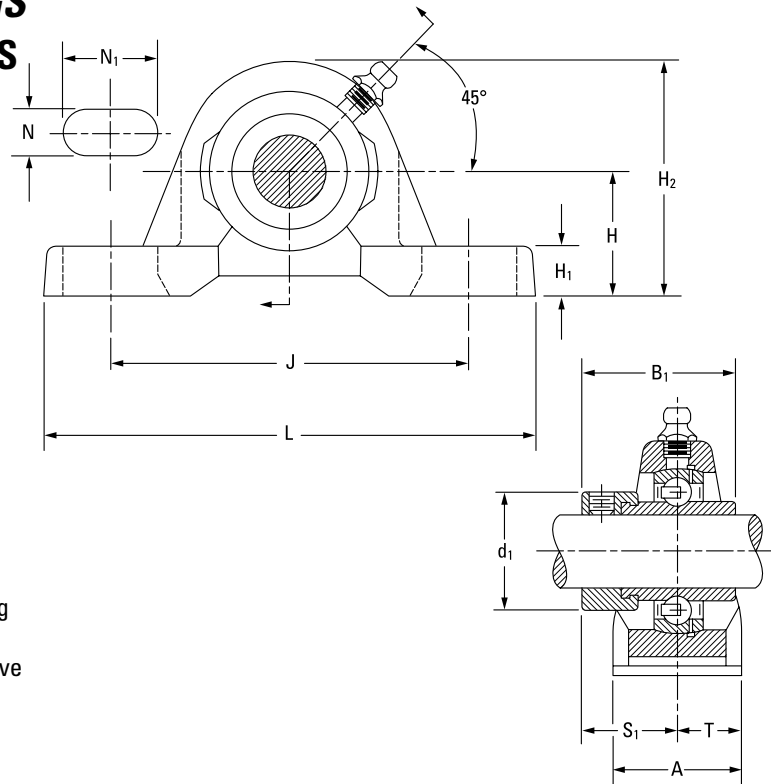

Suggested shaft tolerances:

- 1/2 in. – 1 15/16 in., nominal to -0.013 mm, -0.0005 in.;
- 2 in. – 2 15/16 in., nominal to -0.025 mm, -0.0010 in.

To order, specify UNIT and SHAFT DIAMETER.

Example: RAK 1 7/16 in.

BEARING DATA

Unit	Bearing No.	Dimensions and Load Ratings
RAK	G-KRRB	Page 36
TAK	G-KPPB	Page 41
LAK	G-KLLB	Page 39

Unit	Shaft Dia.	Dimensions													Bolt Size	Bearing No. ⁽¹⁾		Collar No.	Housing No. New (Old)	Unit Wt.	
		H	H ₂	B ₁	J	L	A	H ₁	N	N ₁	d ₁	S ₁	T	RAK		(TAK/LAK)					
	in. mm	mm in.	mm in.	mm in.	mm in.	mm in.	mm in.	mm in.	mm in.	mm in.	mm in.	mm in.	mm in.	mm in.	mm in.	mm in.				kg lbs.	
RAK, LAK	1/2																G1008KRRB	(KLLB)	S1008K		
RAK	9/16																G1009KRRB	(KLLB)	S1009K		
RAK, LAK	5/8	26.99	53.20	37.3	92.1	123.8	30.2	8.7	11.1	22.2	28.6	23.4	15.1	10			G1010KRRB	(KLLB)	S1010K	Z955387	0.454
RAK, LAK	11/16	1 1/16	2 3/32	1 15/32	3 5/8	4 7/8	1 3/16	1 1/32	7/16	7/8	1 1/8	59/64	19/32	3/8			G1011KRRB	(KLLB)	S1011K	(T40238)	1.00
RAK	13/16																G1013KRRB	(KLLB)	S1013K		
RAK	17																GE17KRRB	(KLLB)	SE17K		
RAK, LAK	3/4	31.75	64.30	43.7	96.0	127.0	33.3	13.5	11.1	20.2	33.3	26.6	16.7	10			G1012KRRB	(KLLB)	S1012K	Z955404	0.730
RAK	20	1 1/4	2 17/32	1 23/32	3 29/32	5	1 5/16	17/32	7/16	51/64	1 5/16	1 3/64	21/32	3/8			GE20KRRB	(KLLB)	SE20K	(M96830)	1.61
RAK, TAK, LAK	7/8																G1014KRRB	(KPPB3/KLLB)	S1014K		
RAK, TAK, LAK	15/16	33.34	69.80	44.4	104.8	139.7	37.3	11.9	11.1	20.6	38.1	27.0	18.7	10			G1015KRRB	(KPPB3/KLLB)	S1015K	Z955406	0.950
RAK, TAK, LAK	1	1 5/16	2 3/4	1 3/4	4 1/8	5 1/2	1 15/32	15/32	7/16	13/16	1 1/2	1 1/16	47/64	3/8			G1100KRRB	(KPPB3/KLLB)	S1100K	(M96833)	2.10
RAK, TAK	25																GE25KRRB	(KPPB3)	SE25K		
RAK, TAK	1 1/16																G1101KRRB	(KPPB3)	S1101K		
RAK, TAK, LAK	1 1/8	36.69	81.70	48.4	117.5	157.2	42.9	13.5	14.3	23.8	44.1	30.1	21.4	12			G1102KRRB	(KPPB3/KLLB)	S1102K	Z955408	1.420
RAK, TAK, LAK	1 3/16	1 9/16	3 7/32	1 29/32	4 5/8	6 3/16	1 11/16	17/32	9/16	15/16	1 47/64	1 3/16	27/32	1/2			G1103KRRB	(KPPB3/KLLB)	S1103K	(M96836)	3.14
RAK, TAK	1 1/4 S																G1103KRRB3	(KPPB3/KLLB)	S1103K3		
RAK, TAK, LAK	30																GE30KRRB	(KPPB3/KLLB)	SE30K		

⁽¹⁾Bearing number for RAK is G-KRRB. TAK uses G-KPPB. LAK uses G-KLLB.

NOTE: All units have 1/8 pipe-thread grease fitting except 1/2 – 11/16 and 3/4 units, which have 1/4-28 fitting.

Continued on next page.

MOUNTED BALL BEARINGS

CAST-IRON MOUNTED BEARINGS • RAK, TAK, LAK

RAK, TAK, LAK INDUSTRIAL SERIES – continued

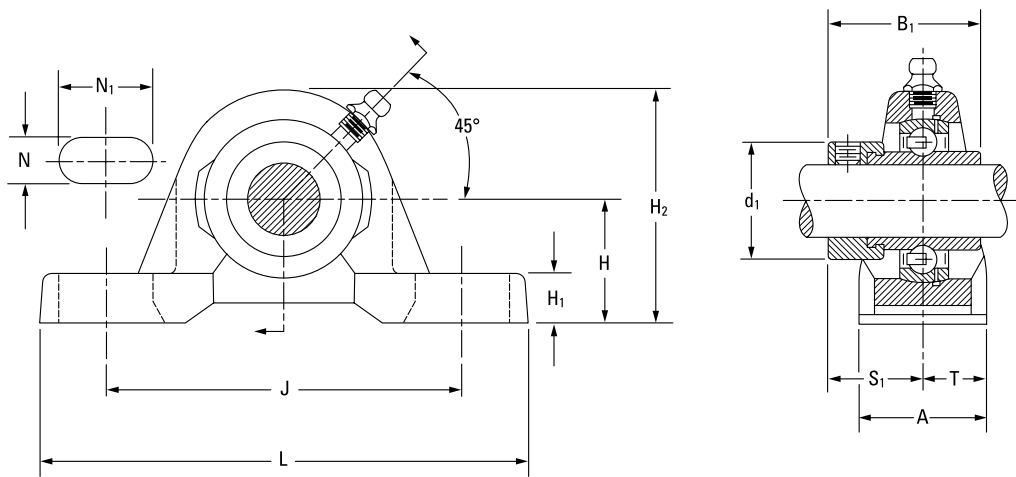

Continued from previous page.

Unit	Shaft Dia.												Bolt Size	Bearing No. ⁽¹⁾		Collar No.	Housing No. New (Old)	Unit Wt.			
		H	H ₂	B ₁	J	L	A	H ₁	N	N ₁	d ₁	S ₁		T	RAK				(TAK/LAK)		
	in. mm	mm in.	mm in.	mm in.	mm in.	mm in.	mm in.	mm in.	mm in.	mm in.	mm in.	mm in.	mm in.	mm in.	mm in.	mm in.	mm in.				kg lbs.
RAK, TAK, LAK	1 1/4																				
RAK, TAK, LAK	1 5/16																				
RAK, TAK, LAK	1 3/8	46.04	93.70	51.2	130.2	166.7	46.8	16.7	14.3	24.6	53.4	32.5	23.4	12	G1104KRRB	(KPPB2/KLLB)	S1104K				
RAK, TAK, LAK	1 7/16	1 13/16	3 11/16	2 1/64	5 1/8	6 9/16	1 27/32	2 1/32	9/16	3 1/32	2 1/8	1 9/32	59/64	1/2	G1105KRRB	(KPPB2/KLLB)	S1105K	Z955410	(M96839)	1.890	4.18
RAK, TAK, LAK	35														G1106KRRB	(KPPB2/KLLB)	S1106K				
RAK, TAK, LAK	1 1/2														G1107KRRB	(KPPB2/KLLB)	S1107K				
RAK, TAK, LAK	1 9/16	49.21	101.60	56.4	136.5	179.4	51.6	19.1	14.3	26.2	60.3	34.9	25.8	12	GE35KRRB	(KPPB2/KLLB)	SE35K				
RAK, TAK, LAK	1 5/8	1 15/16	4	2 7/32	5 3/8	7 1/16	2 1/32	3/4	9/16	1 1/32	2 3/8	1 3/8	1 1/64	1/2	G1108KRRB	(KPPB3/KLLB)	S1108KT	Z955411	(M96842)	2.490	5.50
RAK, TAK, LAK	40														G1109KRRB	(KPPB3)	S1109KT				
RAK, TAK, LAK	1 5/8														GE40KRRB	(KPPB3)	SE40K				
RAK, TAK, LAK	1 11/16	52.39	104.80	56.4	98.4	191.3	52.4	17.5	14.3	28.6	63.5	34.9	26.2	12	G1110KRRB	(KPPB4)	S1110K				
RAK, TAK, LAK	1 3/4	2 1/16	4 1/8	2 7/32	5 7/8	7 17/32	2 1/16	1 1/16	9/16	1 1/8	2 1/2	1 3/8	1 1/32	1/2	G1111KRRB	(KPPB4/KLLB)	S1111K	Z955413	(M96844)	3.200	7.06
RAK, TAK, LAK	45														G1112KRRB	(KPPB4/KLLB)	S1112K				
RAK, TAK, LAK	1 13/16														GE45KRRB	(KPPB4)	SE45K				
RAK, TAK, LAK	1 7/8	55.56	112.70	62.7	158.0	200.0	57.9	17.7	18.3	25.4	69.9	38.1	29.0	16	G1113KRRB	(KPPB3)	S1113K				
RAK, TAK, LAK	1 15/16	2 3/16	4 7/16	2 15/32	6 7/32	7 7/8	2 9/32	1 1/16	23/32	1	2 3/4	1 1/2	1 9/64	5/8	G1114KRRB	(KPPB3)	S1114K	Z955415	(M96847)	4.010	8.86
RAK, TAK, LAK	50														G1115KRRB	(KPPB3/KLLB)	S1115K				
RAK, TAK, LAK	2														GE50KRRB	(KPPB3)	SE50K				
RAK, TAK, LAK	2 1/16														G1200KRRB	(KPPB4/KLLB)	S1200K				
RAK, TAK, LAK	2 1/8	61.91	126.20	71.4	176.2	222.3	60.3	19.0	18.3	29.4	76.2	43.7	30.2	16	G1201KRRB	(KPPB4)	S1201K	Z955417	(M96850)	3.901	8.60
RAK, TAK, LAK	2 3/16	2 7/16	4 31/32	2 13/16	6 15/16	8 3/4	2 3/8	3/4	23/32	1 5/32	3	1 23/32	1 3/16	5/8	G1202KRRB	(KPPB4)	S1202K				
RAK, TAK, LAK	55														G1203KRRB	(KPPB4/KLLB)	S1203K				
RAK, TAK, LAK	2 1/4														GE55KRRB	(KPPB4)	SE55K				
RAK, TAK, LAK	2 5/16														G1204KRRB	(KLLB)	S1204K				
RAK, TAK, LAK	2 3/8	68.26	137.30	77.8	188.1	239.7	60.3	22.2	18.3	29.4	84.1	46.8	30.2	16	G1205KRRB	(KLLB)	S1205K	Z955348	(M99647)	5.511	12.15
RAK, LAK	2 7/16	2 11/16	5 13/32	3 1/16	7 13/32	9 7/16	2 3/8	7/8	23/32	1 5/32	3 5/16	1 27/32	1 3/16	5/8	G1206KRRB	(KLLB)	S1206K				
RAK, LAK	60														G1207KRRB	(KLLB)	S1207K				
RAK, LAK	70														GE60KRRB	(KLLB)	SE60K				
RAK, LAK	2 5/8														G1210KRRB	(KLLB)	S1210KT				
RAK, LAK	2 11/16	76.20	154.00	85.7	203.2	266.7	73.0	33.3	20.6	34.9	96.8	45.2	36.5	20	G1211KRRB	(KLLB)	S1211KT	Z955326	(T22503)	7.920	17.46
RAK, LAK	70	3	6 1/6	3 3/8	8	10 1/2	2 7/8	1 5/16	13/16	1 3/8	3 13/16	1 25/32	1 7/16	3/4	GE70KRRB	(KLLB)	SE70K				
RAK, LAK	2 3/4														G1212KRRB	(KLLB)	S1212K				
RAK, LAK	2 15/16	84.14	163.50	92.1	241.3	304.8	82.6	38.1	22.2	31.8	101.6	54.8	41.3	20	G1215KRRB	(KLLB)	S1215K	Z955325	(T20134)	9.026	19.90
RAK, LAK	75	3 5/16	6 7/16	3 5/8	9 1/2	12	3 1/4	1 1/2	7/8	1 1/4	4	2 5/32	1 5/8	3/4	GE75KRRB	(KLLB)	SE75K				

⁽¹⁾Bearing number for RAK is G-KRRB. TAK uses G-KPPB. LAK uses G-KLLB.
NOTE: All units have 1/8 pipe-thread grease fitting except 1/2 – 1 1/16 and 3/4 units, which have 1/4-28 fitting.

YAK INDUSTRIAL-SERIES SET SCREW UNITS

- Heavier than our standard block with solid, flat feet for increased strength.
- Timken Fafnir series low-base set screw pillow blocks feature the GY-KRRB bearing.
- Well-suited for industrial applications with normal loads due to its full-width inner-ring set screw.
- Housing is designed for two-bolt mounting in any position.
- Pre-lubricated and ready for immediate installation.
- Grease fitting for relubrication.
- Premium Shaft Guarding Technology™ option reduces replacement time, provides shaft protection and prolongs the life of the shaft.
- Contact a Timken engineer to discuss highly corrosive applications (food processing, chemical exposure) where Timken thin-dense chrome-coated bearings can be utilized.

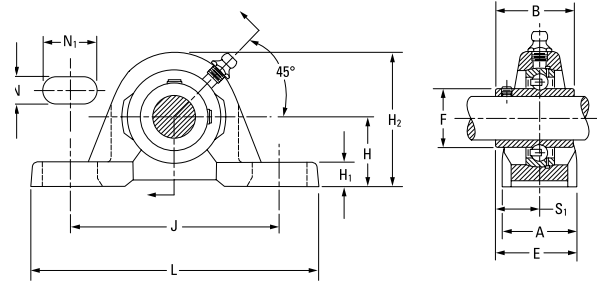

BEARING DATA

Unit	Bearing No.	Dimensions and Load Ratings
YAK	GY-KRRB	Page 46

Suggested shaft tolerances:

- 1/2 in. – 1 15/16 in., nominal to -0.013 mm, -0.0005 in.;
- 2 in. – 2 15/16 in., nominal to -0.025 mm, -0.0010 in.

To order bearing with Shaft Guarding Technology™, specify bearing number followed by "SGT".

Unit	Shaft Dia.	H	H ₂	B	J	L	A	H ₁	N	N ₁	F	S ₁	E	Bolt Size	Bearing No.	Housing No.	Unit Wt.
	in.	mm	mm	mm	mm	mm	mm	mm	mm	mm	mm	mm	mm	mm			kg
	mm	in.	in.	in.	in.	in.	in.	in.	in.	in.	in.	in.	in.	in.			lbs.
YAK	1/2														GY1008KRRB		
YAK	5/8	26.99	53.2	27.4	92.1	123.8	30.2	8.7	11.1	22.2	23.9	15.9	31.0	10	GY1010KRRB	AK 40 MM	0.4536
YAK	17	1 1/16	2 3/32	1 5/64	3 5/8	4 7/8	1 3/16	1 1/32	7/16	7/8	0.940	5/8	1 7/32	3/8	GYE17KRRB		1.0000
YAK ⁽¹⁾	3/4	31.75	64.3	30.9 ⁽²⁾	96.4	127.0	33.3	13.5	11.1	20.2	27.6	18.3 ⁽²⁾	34.9 ⁽²⁾	10	GY1012KRRB ⁽¹⁾	AKR 47 MM	0.6775
YAK ⁽¹⁾	20	1 1/4	2 17/32	1 7/32	3 5 1/64	5	1 5/16	1 7/32	7/16	5 1/64	1.085	2 3/32	1 3/8	3/8	GYE20KRRB ⁽¹⁾		1.4937
YAK ⁽¹⁾	7/8														GY1014KRRB ⁽¹⁾		
YAK ⁽¹⁾	1 5/16	33.32	70.0	34.1 ⁽²⁾	104.8	139.7	37.3	11.9	11.1	20.6	33.8	19.9 ⁽²⁾	38.5 ⁽²⁾	10	GY1015KRRB ⁽¹⁾	AKR 52 MM	0.8924
YAK ⁽¹⁾	1	1 5/16	2 3/4	1 1 1/32	4 1/8	5 1/2	1 15/32	1 5/32	7/16	1 3/16	1.332	2 5/32	1 1 1/2	3/8	GY1100KRRB ⁽¹⁾		1.9673
YAK ⁽¹⁾	25														GYE25KRRB ⁽¹⁾		
YAK ⁽¹⁾	1 1/8														GY1102KRRB ⁽¹⁾		
YAK ⁽¹⁾	1 3/16	39.67	81.7	38.1 ⁽³⁾	117.5	157.2	42.9	13.5	14.3	23.8	40.3	22.2 ⁽³⁾	43.8 ⁽³⁾	12	GY1103KRRB ⁽¹⁾	AKR 62 MM	1.3541
YAK	1 1/4 S	1 9/16	3 7/32	1 1/2	4 5/8	6 3/16	1 1 1/16	1 7/32	9/16	1 5/16	1.587	7/8	1 3/4	1/2	GY1103KRRB3		2.9853
YAK ⁽¹⁾	30														GYE30KRRB ⁽¹⁾		
YAK ⁽¹⁾	1 1/4														GY1104KRRB ⁽¹⁾		
YAK ⁽¹⁾	1 3/8	46.04	93.7	42.9 ⁽⁴⁾	130.2	166.5	46.8	16.7	14.3	24.6	46.8	25.4 ⁽⁴⁾	48.8 ⁽⁴⁾	12	GY1106KRRB ⁽¹⁾	AKR 72 MM	1.8434
YAK ⁽¹⁾	1 7/16	1 13/16	3 1 1/16	1 1 1/16	5 1/8	6 9/16	1 27/32	2 1/32	9/16	3 1/32	1.844	1	1 15/16	1/2	GY1107KRRB ⁽¹⁾		4.0639
YAK ⁽¹⁾	35														GYE35KRRB ⁽¹⁾		
YAK ⁽¹⁾	1 1/2	49.23	101.6	49.2	136.5	179.4	51.6	19.1	14.3	26.2	52.3	30.2	56.0	12	GY1108KRRB ⁽¹⁾	AKR 80 MM	2.4763
YAK ⁽¹⁾	40	1 15/16	4	1 15/16	5 3/8	7 1/16	2 1/32	3/4	9/16	1 1/32	2.058	1 3/16	2 1/4	1/2	GYE40KRRB ⁽¹⁾		5.4592
YAK ⁽¹⁾	1 5/8														GY1110KRRB ⁽¹⁾		
YAK ⁽¹⁾	1 1 1/16	52.37	104.8	49.2 ⁽⁵⁾	149.2	191.1	52.4	17.5	14.3	28.6	57.9	30.2 ⁽⁵⁾	56.4 ⁽⁵⁾	12	GY1111KRRB ⁽¹⁾	AKR 85 MM	2.6311
YAK ⁽¹⁾	1 3/4	2 1/16	4 1/8	1 15/16	5 7/8	7 17/32	2 1/16	1 1/16	9/16	1 1/8	2.280	1 3/16	2 1/4	1/2	GY1112KRRB ⁽¹⁾		5.8005
YAK ⁽¹⁾	45														GYE45KRRB ⁽¹⁾		
YAK ⁽¹⁾	1 15/16														GY1115KRRB ⁽¹⁾		
YAK	2 S	55.58	112.7	51.6	158.0	199.8	57.9	17.5	18.3	25.4	62.8	32.5	61.5	16	GY1115KRRB2	AKR 90 MM	3.2579
YAK ⁽¹⁾	50	2 3/16	4 7/16	2 1/32	6 7/32	7 7/8	2 9/32	1 1/16	2 3/32	1	2.474	1 9/32	2 27/64	5/8	GYE50KRRB ⁽¹⁾		7.1824
YAK ⁽¹⁾	2														GY1200KRRB ⁽¹⁾		
YAK ⁽¹⁾	2 3/16	61.91	126.2	55.6	176.2	222.0	60.3	19.1	18.3	29.4	69.8	33.3	63.5	16	GY1203KRRB ⁽¹⁾	AKR 100 MM	3.9009
YAK	2 1/4 S	2 7/16	4 3 1/32	2 3/16	6 15/16	8 3/4	2 3/8	3/4	2 3/32	1 5/32	2.747	1 5/16	2 1/2	5/8	GY1203KRRB3		8.6000
YAK ⁽¹⁾	55														GYE55KRRB ⁽¹⁾		
YAK ⁽¹⁾	2 1/4														GY1204KRRB ⁽¹⁾		
YAK ⁽¹⁾	2 7/16	68.26	137.3	65.1	188.1	239.7	60.3	22.2	18.3	29.4	76.5	39.7	69.9	16	GY1207KRRB ⁽¹⁾	AKR 110 MM	4.7718
YAK ⁽¹⁾	60	2 1 1/16	5 13/32	2 9/16	7 13/32	9 7/16	2 3/8	7/8	2 3/32	1 5/32	3.011	1 9/16	2 3/4	5/8	GYE60KRRB ⁽¹⁾		10.5200
YAK ⁽¹⁾	2 1 1/16	76.20	154.0	69.9	203.2	266.7	73.0	33.3	20.6	34.9	86.9	42.9	79.4	20	GY1211KRRB ⁽¹⁾	AK 125 MM	7.1259
YAK ⁽¹⁾	70	3	6 1/16	2 3/4	8	10 1/2	2 7/8	1 5/16	1 3/16	1 3/8	3.422	1 1 1/16	3 1/8	3/4	GYE70KRRB ⁽¹⁾		15.7100
YAK ⁽¹⁾	2 15/16	84.14	163.5	77.8	241.3	304.8	82.6	38.1	22.2	31.8	91.9	44.5	85.7	20	GY1215KRRB ⁽¹⁾	AK 130 MM	8.5185
YAK ⁽¹⁾	75	3 3/16	6 7/16	3 1/16	9 1/2	12	3 1/4	1 1/2	7/8	1 1/4	3.619	1 3/4	3 3/8	3/4	GY75KRRB ⁽¹⁾		18.7800

NOTE: Shaft diameter with an S = smaller housing.
⁽¹⁾ Shaft Guard Technology available
⁽²⁾ Inner Ring with SGT is wider by 0.737mm [0.029 in.]
⁽³⁾ Inner Ring with SGT is wider by 1.016mm [0.040 in.]
⁽⁴⁾ Inner Ring with SGT is wider by 2.540mm [0.100 in.]
⁽⁵⁾ Inner Ring with SGT is wider by 1.143mm [0.045 in.]

MOUNTED BALL BEARINGS

CAST-IRON MOUNTED BEARINGS • VAK

VAK STANDARD SERIES

- The streamlined and rugged VAK pillow block unit combines an engineered housing and an RA-RR extended inner ring bearing.
- RA-RR bearing employs a positive-contact, land-riding seal and a Timken Fafnir self-locking collar. Collar ensures positive shaft retention.
- The pillow block can be mounted to operate in any position.
- Mounted bearings are factory-prelubricated, but a grease fitting is provided to allow for relubrication if required.

Suggested shaft tolerances:

1/2 in. – 1 15/16 in., nominal to -0.013 mm, -0.0005 in.;
 2 in. – 2 3/16 in., nominal to -0.025 mm, -0.0010 in.

To order, specify UNIT and SHAFT DIAMETER.

Example: VAK 1 7/16 in.

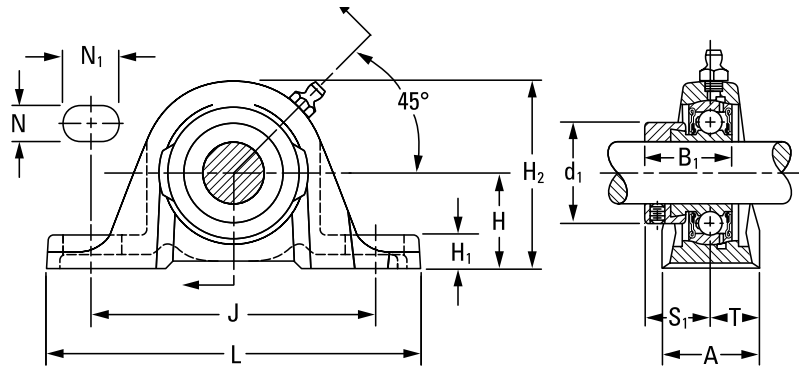

BEARING DATA

Unit	Bearing No.	Dimensions and Load Ratings
VAK	GRA-RRB	Page 52

Unit	Shaft Dia.	Dimensions											Bolt Size	Bearing No.	Collar No.	Housing No. New (Old)	Unit Wt. kg lbs.	
		H	H ₂	B ₁	J	L	A	H ₁	N	N ₁	d ₁	S ₁						T
	in. mm	mm in.	mm in.	mm in.	mm in.	mm in.	mm in.	mm in.	mm in.	mm in.	mm in.	mm in.	mm in.	mm in.				
VAK	1/2	26.99	53.2	28.6	92.1	123.8	30.2	8.7	11.1	22.2	28.6	22.2	15.1	10	GRA008RRB	S1008K	Z955387 (T40238)	0.454
VAK	5/8	1 1/16	2 3/32	1 1/8	3 5/8	4 7/8	1 3/16	1 1/32	7/16	7/8	1 1/8	7/8	19/32	3/8	GRA010RRB	S1010K		1.00
VAK	17														GRAE17RRB	SE17K		
VAK	3/4	31.75	62.7	31.0	96.0	127.0	31.8	11.9	11.1	19.8	33.3	23.4	15.9	10	GRA012RRB	S1012K	Z955389 (T40239)	0.563
VAK	20	1 1/4	2 15/32	1 7/32	3 25/32	5	1 1/4	15/32	7/16	25/32	1 5/16	59/64	5/8	3/8	GRAE20RRB	SE20K		1.24
VAK	7/8	33.34	68.3	31.0	104.8	139.7	35.7	11.9	11.1	20.6	38.1	23.4	17.9	10	GRA014RRB	S1014K		
VAK	15/16	1 5/16	2 11/16	1 7/32	4 1/8	5 1/2	1 13/32	15/32	7/16	13/16	1 1/2	59/64	45/64	3/8	GRA015RRB	S1015K	Z955391 (T30365)	0.758
VAK	1														GRA100RRB	S1100K		1.67
VAK	25														GRAE25RRB	SE25K		
VAK	1 1/8	39.69	80.2	35.7	117.5	157.2	39.7	13.5	14.3	23.8	44.1	27.0	19.9	12	GRA102RRB	S1102K		
VAK	1 3/16	1 9/16	3 5/32	1 13/32	4 5/8	6 3/16	1 9/16	17/32	9/16	15/16	1 47/64	1 1/16	25/32	1/2	GRA103RRB	S1103K	Z955393 (T40241)	1.235
VAK	1 1/4 S														GRA103RRB2	S1103K3		2.72
VAK	30														GRAE30RRB	SE30K		
VAK	1 1/4	46.04	92.1	38.9	130.2	166.7	45.2	16.7	14.3	24.6	54.0	29.4	22.7	12	GRA104RRB	S1104K		
VAK	1 3/8	1 13/16	3 5/8	1 17/32	5 1/8	6 9/16	1 25/32	2 1/32	9/16	3 1/32	2 1/8	1 5/32	57/64	1/2	GRA106RRB	S1106K	Z955395 (T40242)	1.594
VAK	1 7/16														GRA107RRB	S1107K		3.51
VAK	35														GRAE35RRB	SE35K		
VAK	1 1/2	49.21	100.0	43.7	136.5	179.4	47.6	19.0	14.3	26.2	60.3	32.5	23.8	12	GRA108RRB	S1108KT		
VAK	1 9/16	1 15/16	3 15/16	1 23/32	5 3/8	7 1/16	1 7/8	3/4	9/16	1 1/32	2 3/8	1 9/32	15/16	1/2	GRA109RRB	S1109KT	Z955396 (T40243)	2.034
VAK	40														GRAE40RRB	SE40K		4.48
VAK	1 5/8	52.39	104.8	43.7	149.2	191.3	50.8	17.5	14.3	28.6	63.5	32.5	25.4	12	GRA110RRB	S1110K		
VAK	1 11/16	2 1/16	4 1/8	1 23/32	5 7/8	7 17/32	2	1 1/16	9/16	1 1/8	2 1/2	1 9/32	1	1/2	GRA111RRB	S1111K	Z955398 (T40244)	2.261
VAK	1 3/4														GRA112RRB	S1112K		4.98
VAK	45														GRAE45RRB	SE45K		
VAK	1 7/8	55.56	112.7	43.7	158.0	200.0	55.6	17.5	17.5	23.8	69.8	32.5	27.8	16	GRA114RRB	S1114K		
VAK	1 15/16	2 3/16	4 7/16	1 23/32	6 7/32	7 7/8	2 3/16	1 1/16	1 1/16	15/16	2 3/4	1 9/32	1 3/32	5/8	GRA115RRB	S1115K	Z955400 (T40245)	2.774
VAK	2 S														GRA115RRB2	S1115K2		6.11
VAK	50														GRAE50RRB	SE50K		
VAK	2	61.91	124.6	48.4	176.2	222.3	58.7	19.0	18.3	29.4	76.2	36.5	29.4	16	GRA200RRB	S1200K		
VAK	2 3/16	2 7/16	4 29/32	1 29/32	6 15/16	8 3/4	2 5/16	3/4	23/32	1 5/32	3	1 7/16	1 5/32	5/8	GRA203RRB	S1203K	Z955402 (T40246)	3.328
VAK	55														GRAE55RRB	SE55K		7.33

NOTE: All units have 1/8 pipe-thread grease fitting except 1/2 – 1 1/16 and 3/4 units, which have 1/4-28 fitting.

NOTE: Shaft diameter with an S = smaller housing.

SAK STANDARD SERIES

- The streamlined, rugged, one-piece pillow block combines an RAK housing and GYA-RRB set screw bearing.
- GYA-RRB bearing employs a positive-contact, land-riding seal and specially designed set screws.
- This pillow block can be mounted to operate in any position.
- Mounted bearings are factory-prelubricated, but a grease fitting is provided to allow for relubrication if required.

Suggested shaft tolerances:

1/2 in. – 1 15/16 in., nominal to -0.013 mm, -0.0005 in.;

2 in. – 2 3/16 in., nominal -0.025 mm, -0.0010 in.

To order, specify UNIT and SHAFT DIAMETER.

Example: SAK 1 in.

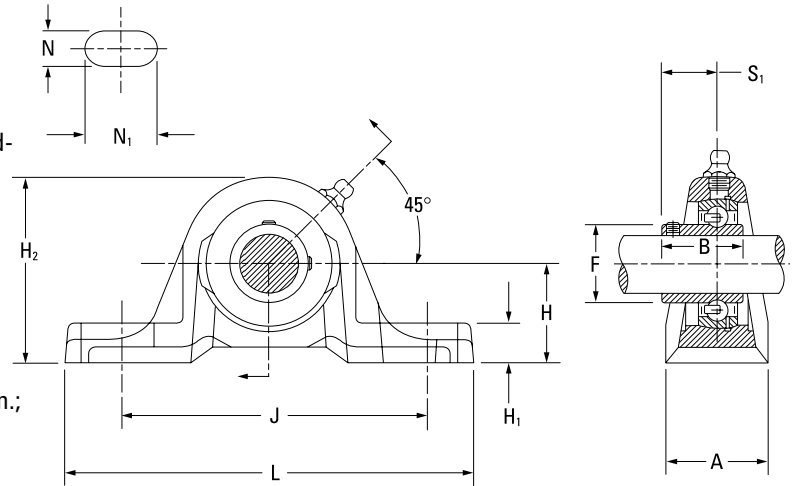

BEARING DATA

Unit	Bearing No.	Dimensions and Load Ratings
SAK	GYA-RRB	Page 56

Unit	Shaft Dia.	Basic Bearing No.	Dimensions											Bolt Size	Bearing No.	Housing No. New (Old)	Unit Wt.
			H	H ₂	S ₁	J	L	A	H ₁	N	N ₁	F	B				
	in. mm	mm in.	mm in.	mm in.	mm in.	mm in.	mm in.	mm in.	mm in.	mm in.	mm in.	mm in.	mm in.				kg lbs.
SAK 1/2	203	17	26.99	53.2	15.9	92.1	123.8	30.2	8.7	11.1	22.2	24.6	23.8	10	GYA008RRB GYA010RRB GYAE17RRB	Z955387 (T40238)	0.42
SAK 5/8			1 1/16	2 3/32	5/8	3 5/8	4 7/8	1 3/16	1 1/32	7/16	7/8	3 1/32	1 5/16	3/8			0.92
SAK 1																	
SAK 3/4	204	20	31.75	62.7	18.3	96.0	127	31.8	11.9	11.1	19.8	29.0	31.8	10	GYA012RRB GYAE20RRB	Z955389 (T40239)	0.57
SAK 7/8			1 1/4	2 15/32	23/32	3 25/32	5	1 1/4	1 5/32	7/16	2 5/32	1 9/64	1 1/16	3/8			1.25
SAK 1 1/8																	
SAK 1 1/16	205	25	33.34	68	19.4	104.8	139.7	35.7	11.9	11.1	20.6	33.7	34.9	10	GYA014RRB GYA015RRB GYA100RRB GYAE25RRB	Z955391 (T30365)	0.76
SAK 1			1 5/16	2 11/16	4 9/64	4 1/8	5 1/2	1 13/32	1 9/32	7/16	1 3/16	1 21/64	1 7/64	3/8			1.67
SAK 1 1/8																	
SAK 1 3/16	206	30	39.69	80.2	23.0	117.5	157.2	39.7	13.5	14.3	23.8	40.1	32.5	12	GYA102RRB GYA103RRB GYA103RRB2 GYAE30RRB	Z955393 (T40241)	1.14
SAK 1 1/4 S			1 9/16	3 3/32	2 9/32	4 5/8	6 3/16	1 9/16	1 7/32	9/16	1 5/16	1 37/64	1 9/32	1/2			2.52
SAK 1 3/8																	
SAK 1 7/16	207	35	46.04	92.1	25.8	130.2	166.7	45.2	16.7	14.3	24.6	46.8	36.5	12	GYA104RRB GYA106RRB GYA107RRB GYAE35RRB	Z955395 (T40242)	1.52
SAK 1 3/8			1 13/16	3 5/8	1 1/64	5 1/8	6 9/16	1 25/32	2 1/32	9/16	3 1/32	1 70/63	1 7/16	1/2			3.35
SAK 1 7/16																	
SAK 1 1/2	208	40	49.21	100.0	27.8	136.5	179.4	47.6	19.1	14.3	26.2	52.4	39.3	12	GYA108RRB GYAE40RRB	Z956392 (T40243)	1.85
SAK 1 1/2			1 15/16	3 15/16	1 3/32	5 3/8	7 1/16	1 7/8	3/4	9/16	1 1/32	2 1/16	1 35/64	1/2			4.08
SAK 1 5/8																	
SAK 1 11/16	209	45	52.39	104.8	28.6	149.2	191.3	50.8	17.5	14.3	28.6	57.9	42.1	12	GYA110RRB GYA111RRB GYA112RRB GYAE45RRB	Z955398 (T40244)	2.06
SAK 1 3/4			2 1/16	4 1/8	1 1/8	5 7/8	7 17/32	2	1 1/16	9/16	1 1/8	2 9/32	1 21/32	1/2			4.55
SAK 1 15/16																	
SAK 2S	210	50	55.56	112.7	31.0	158.0	200.2	55.6	17.5	17.5	23.8	62.7	44.5	16	GYA115RRB GYA115RRB2 GYAE50RRB	Z955400 (T40245)	2.54
SAK 2			2 3/16	4 7/16	1 1/32	6 1/32	7 7/8	2 3/16	1 1/16	1 1/16	1 5/16	2 15/32	1 3/4	5/8			5.60
SAK 2 3/16																	
SAK 2 1/2	211	55	61.91	124.6	31.8	176.2	222.3	58.7	19.1	18.3	29.4	69.9	46.4	16	GYA200RRB GYA203RRB GYAE55RRB	Z955402 (T40246)	3.02
SAK 2 3/16			2 7/16	4 29/32	1 1/4	6 15/16	8 3/4	2 5/16	3/4	23/32	1 5/32	2 3/4	1 53/64	5/8			6.66
SAK 2 1/2																	

NOTE: All units have a 1/8 pipe-thread grease fitting except 1/2 – 1 1/16 and 3/4 units which have 1/4-28 fitting.

RAS, TAS, LAS INDUSTRIAL SERIES

- Heavier than our standard block with solid, flat feet for increased strength.
- Timken RAS, TAS and LAS pillow blocks are similar in design and equal in load-carrying capacity to the RAK, TAK and LAK types.
- RAS, TAS and LAS types have a slightly higher base-to-center height dimension than the RAK, TAK and LAK types, making them interchangeable with other competitive designs.
- The RAS pillow block is equipped with G-KRRB (R-seal) wide-inner-ring ball bearings, the TAS with G-KPPB (tri-ply seal) wide-inner-ring ball bearings, and the LAS with the G-KLLB (Mechani-seal) wide-inner-ring ball bearings.
- Contact your Timken engineer to discuss highly corrosive applications (food processing, chemical exposure) where Timken thin-dense chrome-coated bearings can be utilized.

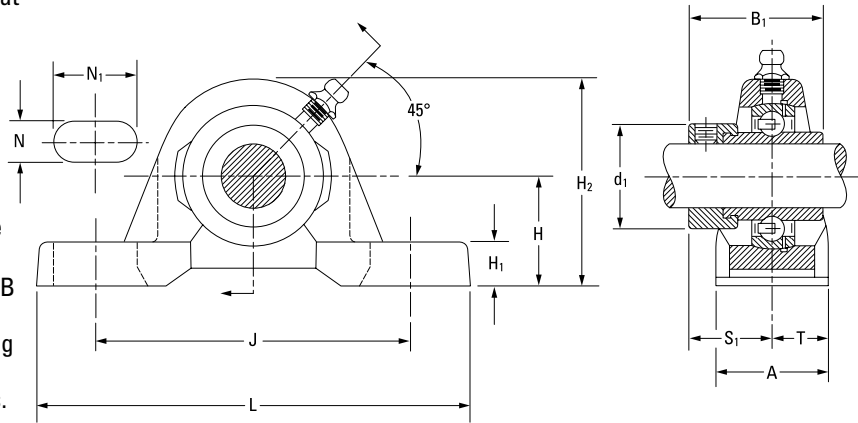

Suggested shaft tolerances:

- 1/2 in. – 1 15/16 in., nominal to -0.013 mm, -0.0005 in.;
- 2 in. – 2 15/16 in., nominal to -0.025 mm, -0.0010 in.

To order, specify UNIT and SHAFT DIAMETER.

Example: RAS 1 3/16 in.

BEARING DATA

Unit	Bearing No.	Dimensions and Load Ratings
RAS	G-KRRB	Page 36
TAS	G-KPPB	Page 41
LAS	G-KLLB	Page 39

Unit	Shaft Dia.	Dimensions													Bolt Size	Bearing No. ⁽¹⁾		Collar No.	Housing No. New (Old)	Unit Wt.	
		H	H ₂	B ₁	J	L	A	H ₁	N	N ₁	d ₁	S ₁	T	RAS		(TAS/LAS)					
	in. mm	mm in.	mm in.	mm in.	mm in.	mm in.	mm in.	mm in.	mm in.	mm in.	mm in.	mm in.	mm in.	mm in.	mm in.	mm in.				kg lbs.	
RAS	1/2																G1008KRRB		S1008K		
RAS	5/8	30.16	56.4	37.3	92.1	123.8	30.2	11.9	11.1	22.2	28.6	23.4	15.1	10			G1010KRRB		S1010K	Z955386	0.454
RAS	11/16	1 3/16	2 7/32	1 15/32	3 5/8	4 7/8	1 3/16	1 5/32	7/16	7/8	1 1/8	59/64	19/32	3/8			G1011KRRB		S1011K	(T40238)	1.00
RAS	17																GE17KRRB		SE17K		
RAS,LAS	3/4	33.34	65.9	43.7	96.4	127.0	33.3	15.1	11.1	20.2	33.3	26.6	16.7	10			G1012KRRB	(KLLB)	S1012K	Z955403	0.730
RAS	20	1 5/16	2 19/32	1 29/32	3 51/64	5	1 5/16	19/32	7/16	51/64	1 5/16	1 3/64	21/32	3/8			GE20KRRB		SE20K	(M96830)	1.610
RAS	13/16																G1013KRRB				
RAS,TAS	7/8																G1014KRRB	(KPPB3)	S1014K		
RAS,TAS	15/16	36.51	73.0	44.4	104.8	139.7	37.3	15.1	11.1	20.6	38.1	27.0	18.7	10			G1015KRRB	(KPPB3)	S1015K	Z955405	0.95
RAS,TAS,LAS	1	1 7/16	2 7/8	1 3/4	4 1/8	5 1/2	1 15/32	19/32	7/16	13/16	1 1/2	1 1/16	47/64	3/8			G1100KRRB	(KPPB3)	S1100K	(M96833)	2.10
RAS,TAS	25																GE25KRRB	(KPPB3)	SE25K		
RAS,TAS	1 1/16																G1101KRRB	(KPPB3)	S1101K		
RAS,TAS	1 1/8	42.86	84.9	48.4	117.5	157.2	42.9	16.7	14.3	23.8	44.1	30.1	21.4	12			G1102KRRB	(KPPB3)	S1102K	Z955407	1.420
RAS,TAS,LAS	1 3/16	1 11/16	3 11/32	1 29/32	4 5/8	6 3/16	1 11/16	21/32	9/16	15/16	1 47/64	1 3/16	27/32	1/2			G1103KRRB	(KPPB3/KLLB3)	S1103K	(M96836)	3.14
RAS,TAS	30																GE30KRRB	(KPPB3)	SE30K		
RAS,TAS	1 1/4																G1104KRRB	(KPPB2)	S1104K		
RAS,TAS	1 5/16																G1105KRRB	(KPPB2)	S1105K		
RAS,TAS	1 3/8	47.63	95.3	51.2	130.2	166.7	46.8	18.3	14.3	24.6	54.0	32.5	23.4	12			G1106KRRB	(KPPB2)	S1106K	Z955409	1.890
RAS,TAS,LAS	1 7/8	1 7/8	3 3/4	2 1/64	5 1/8	6 9/16	1 27/32	23/32	9/16	31/32	2 1/8	1 9/32	59/64	1/2			G1107KRRB	(KPPB2/KLLB)	S1107K	(M96839)	4.18
RAS,TAS	35																GE35KRRB	(KPPB2)	SE35K		

⁽¹⁾Bearing number for RAS is G-KRRB. TAS uses G-KPPB. LAS uses G-KLLB.
NOTE: All units have 1/8 pipe-thread grease fitting except 1/2 – 1 1/16 and 3/4 units, which have 1/4-28 fitting.

Continued on next page.

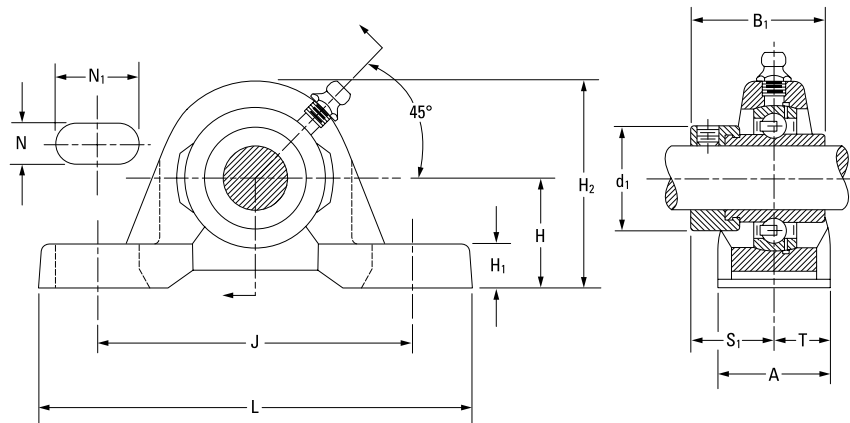

Continued from previous page.

Unit	Shaft Dia.													Bolt Size	Bearing No. ⁽¹⁾		Collar No.	Housing No. New (Old)	Unit Wt.
		H	H ₂	B ₁	J	L	A	H ₁	N	N ₁	d ₁	S ₁	T		RAS	(TAS/LAS)			
	in. mm	mm in.	mm in.	mm in.	mm in.	mm in.	mm in.	mm in.	mm in.	mm in.	mm in.	mm in.	mm in.	mm in.	mm in.				kg lbs.
RAS,TAS	1 1/2	49.21	101.6	56.4	136.5	179.4	51.6	19.1	14.3	26.2	60.3	34.9	25.8	12	G1108KRRB	(KPPB3)	S1108KT		
RAS,TAS	1 9/16	1 15/16	4	2 7/32	5 3/8	7 1/16	2 1/32	3/4	9/16	1 1/32	2 3/8	1 3/8	1 1/64	1/2	G1109KRRB	(KPPB3)	S1109KT	Z955411	2.490
RAS,TAS	40														GE40KRRB	(KPPB3)	SE40K	(M96842)	5.50
RAS,TAS	1 5/8														G1110KRRB	(KPPB4)	S1110K		
RAS,TAS	1 11/16	53.98	106.4	56.4	149.2	191.3	52.4	19.1	14.3	28.6	63.5	34.9	26.2	12	G1111KRRB	(KPPB4)	S1111K	Z955412	3.200
RAS,TAS	1 3/4	2 1/8	4 3/16	2 7/32	5 7/8	7 17/32	2 1/16	3/4	9/16	1 1/8	2 1/2	1 3/8	1 1/32	1/2	G1112KRRB	(KPPB4)	S1112K	(M96844)	7.06
RAS,TAS	45														GE45KRRB	(KPPB4)	SE45K		
RAS	1 13/16														G1113KRRB	C1	S1113K		
RAS,TAS	1 7/8	57.15	114.3	62.7	158.0	200.0	57.9	19.1	18.3	25.4	69.9	38.1	29.0	16	G1114KRRB	(KPPB3)	S1114K	Z955414	4.010
RAS,TAS,LAS	1 15/16	2 1/4	4 1/2	2 15/32	6 7/32	7 7/8	2 9/32	3/4	23/32	1	2 3/4	1 1/2	1 9/64	5/8	G1115KRRB	(KPPB3)	S1115K	(M96847)	8.86
RAS,TAS	50														GE50KRRB	(KPPB3)	SE50K		
RAS,TAS	2														G1200KRRB	(KPPB4)	S1200K		
RAS,TAS	2 1/8	63.50	127.8	71.4	176.2	222.3	60.3	20.6	18.3	29.4	76.2	43.7	30.2	16	G1202KRRB	(KPPB4)	S1202K	Z955416	3.901
RAS,TAS	2 3/16	2 1/2	5 1/32	2 13/16	6 15/16	8 3/4	2 3/8	1 3/16	23/32	1 5/32	3	1 23/32	1 3/16	5/8	G1203KRRB	(KPPB4)	S1203K	(M96850)	8.60
RAS,TAS	55														GE55KRRB	(KPPB4)	SE55K		
RAS	2 1/4														G1204KRRB		S1204K		
RAS	2 3/8	69.85	138.9	77.8	188.1	239.7	60.3	23.8	18.3	29.4	84.1	46.8	30.2	16	G1206KRRB		S1206K	Z955347	5.511
RAS,LAS	2 7/16	2 3/4	5 15/32	3 1/16	7 13/32	9 7/16	2 3/8	1 5/16	23/32	1 5/32	3 5/16	1 27/32	1 3/16	5/8	G1207KRRB	(KLLB)	S1207K	(M9647)	12.15
RAS	60														GE60KRRB		SE60K		
RAS	2 15/16	82.55	164.3	92.1	215.9	269.9	69.9	25.4	22.2	31.8	101.6	54.8	34.9	20	G1215KRRB		S1215K	Z955333	9.026
RAS	75	3 1/4	6 15/32	3 5/8	8 1/2	10 5/8	2 3/4	1	7/8	1 1/4	4	2 5/32	1 3/8	3/4	GE75KRRB		SE75K	(T23423)	19.90

⁽¹⁾Bearing number for RAS is G-KRRB. TAS uses G-KPPB. LAS uses G-KLLB.

NOTE: All units have 1/8 pipe-thread grease fitting except 1/2 - 1/16 and 3/4 units, which have 1/4-28 fitting.

RASC INDUSTRIAL-SERIES CONCENTRIC COLLAR

- Heavier than our standard block with solid, flat feet for increased strength.
- All RASC pillow blocks are equipped with GC-KRRB (R-seal) wide-inner-ring ball bearings with concentric collars.
- Pillow blocks self-align at mounting with the spherical outside diameter of the bearing fitting into a corresponding spherical housing seat.
- Units are prelubricated and ready for immediate installation.
- Grease fitting provides for relubrication if required.
- Concentric collars are supplied with all units.

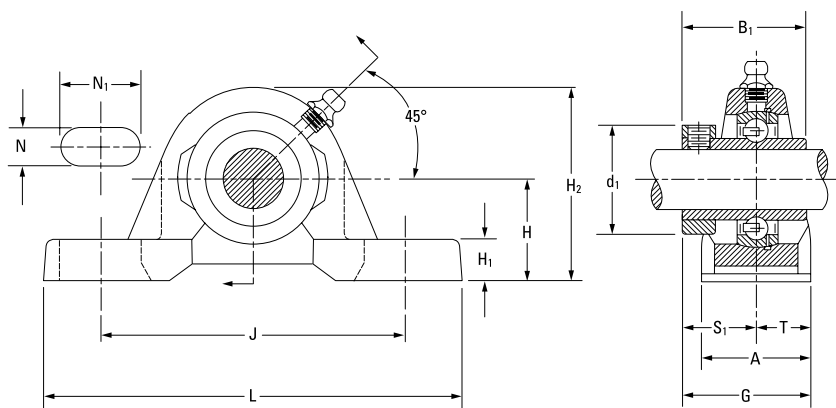

Suggested shaft tolerances:

- 1/2 in. – 1 15/16 in., nominal to -0.013 mm, -0.0005 in.;
- 2 in. – 2 15/16 in., nominal to -0.025 mm, -0.0010 in.

To order, specify UNIT and SHAFT DIAMETER.

Example: RASC 1 in.

BEARING DATA

Unit	Bearing No.	Dimensions and Load Ratings
RASC	GC-KRRB	Page 42

Unit	Shaft Dia.	Dimensions (mm)													Bolt Size	Bearing No.	Collar No.	Housing No. New (Old)	Unit Wt.		
		H	H ₂	B ₁	J	L	A	H ₁	N	N ₁	d ₁	S ₁	T	G							
	in.	mm in.	mm in.	mm in.	mm in.	mm in.	mm in.	mm in.	mm in.	mm in.	mm in.	mm in.	mm in.	mm in.	mm in.	mm in.	mm in.	mm in.	mm in.	kg lbs.	
RASC	1/2																				
RASC	5/8	30.16 1 3/16	56.4 2 1/32	26.6 1 3/64	92.1 3 5/8	123.8 4 7/8	30.2 1 3/16	11.9 15/32	11.1 7/16	22.2 7/8	34.1 1 11/32	15.5 39/64	15.08 19/32	30.53 1 13/64	10 3/8	GC1008KRRB GC1010KRRB GC1011KRRB	C203	Z955386 (T40238)	0.454 1.00		
RASC	1 1/16																				
RASC	3/4	33.34 1 5/16	65.9 2 19/32	31.0 1 7/32	96.0 3 25/32	127.0 5	33.3 1 5/16	15.1 19/32	11.1 7/16	19.8 25/32	38.1 1 1/2	18.7 47/64	16.70 21/32	35.32 1 25/64	10 3/8	GC1012KRRB	C204	Z955403 (M96830)	0.635 1.40		
RASC	7/8																				
RASC	15/16	36.51 1 7/16	73.0 2 7/8	34.1 1 11/32	104.8 4 1/8	139.7 5 1/2	37.3 1 15/32	15.1 19/32	11.1 7/16	20.2 13/16	44.4 1 3/4	20.2 51/64	18.70 47/64	38.89 1 17/32	10 3/8	GC1014KRRB GC1015KRRB GC1100KRRB	C205	Z955405 (M96833)	0.803 1.77		
RASC	1																				
RASC	1 1/8	42.86 1 11/16	84.9 3 11/32	37.3 1 15/32	117.5 4 5/8	157.2 6 3/16	42.9 1 11/16	16.7 21/32	14.3 9/16	23.8 15/16	52.4 2 1/16	22.6 57/64	21.40 27/32	44.05 1 47/64	12 1/2	GC1102KRRB GC1103KRRB GC1103KRRB3	C206	Z955407 (M96836)	1.297 2.86		
RASC	1 1/4																				
RASC	1 3/8	47.62 1 7/8	95.3 3 3/4	41.3 1 5/8	130.2 5 1/8	166.7 6 9/16	46.8 1 27/32	18.3 23/32	14.3 9/16	24.6 31/32	59.5 2 11/32	25.4 1	23.40 59/64	48.81 1 59/64	12 1/2	GC1104KRRB GC1106KRRB GC1107KRRB	C207	Z955409 (M96839)	1.674 3.69		
RASC	1 7/16																				
RASC	1 1/2	49.21 1 15/16	101.6 4	44.1 1 47/64	136.5 5 3/8	179.4 7 1/16	51.6 2 1/32	19.1 3/4	14.3 9/16	26.2 1 1/32	68.3 2 11/16	27.4 1 5/64	25.80 1 1/64	53.16 2 15/16	12 1/2	GC1108KRRB	C208	Z955411 (M96842)	2.150 4.74		
RASC	1 5/8																				
RASC	1 11/16	53.98 2 1/8	106.4 4 3/16	46.8 1 27/32	149.2 5 7/8	191.3 7 17/32	52.4 2 1/16	19.1 3/4	14.3 9/16	23.0 29/32	73.0 2 7/8	29.4 1 5/32	26.20 1 1/32	55.55 2 3/16	12 1/2	GC1110KRRB GC1111KRRB GC1112KRRB	C209	Z955412 (M96844)	2.409 5.31		
RASC	1 3/4																				
RASC	1 15/16	57.15 2 1/4	114.3 4 1/2	48.4 1 29/32	158.0 6 7/32	200.0 7 7/8	57.9 2 9/32	19.1 3/4	17.5 11/16	23.8 15/16	79.4 3 1/8	30.2 1 3/16	29.00 1 9/64	59.13 2 21/64	16 5/8	GC1115KRRB	C210	Z955414 (M96847)	3.003 6.62		
RASC	2	63.50 2 1/2	127.8 5 1/32	54.0 2 1/8	176.2 6 19/16	222.3 8 3/4	60.3 2 3/8	20.6 13/16	18.3 23/32	29.4 1 5/32	88.9 3 1/2	33.3 1 5/16	30.20 1 3/16	62.70 2 19/32	16 5/8	GC1200KRRB GC1203KRRG	C211	Z955416 (M96850)	3.901 8.60		
RASC	2 3/16																				
RASC	2 7/16	69.85 2 3/4	138.9 5 15/32	60.3 2 3/8	188.1 7 13/32	239.7 9 7/16	60.3 2 3/8	23.8 15/16	18.3 23/32	29.4 1 5/32	95.2 3 3/4	37.3 1 15/32	30.20 1 3/16	67.46 2 21/32	16 5/8	GC1207KRRB	C212	Z955347 (M99647)	5.511 12.15		
RASC	2 15/16	82.55 3 1/4	164.3 6 15/32	70.6 2 29/32	215.9 8 1/2	269.9 10 5/8	69.9 2 3/4	25.4 1	22.2 7/8	31.8 1 1/4	114.3 4 1/2	43.7 1 23/32	34.90 1 3/8	78.60 3 3/32	20 3/4	GC1215KRRB	C215	T90049 (T23423)	9.060 19.91		

NOTE: All units have 1/8 pipe-thread grease fitting except RASC 1/2 – 1 15/16 and 3/4 units, which have 1/4-28 fitting.

YAS INDUSTRIAL-SERIES SET SCREW UNITS

- Heavier than our standard block with solid, flat feet for increased strength.
- Timken Fafnir YAS-series high-base, set screw pillow blocks feature the GY-KRRB bearing.
- This full-width inner ring set screw is well-suited for industrial applications involving wet or dirty environments.
- Housing is designed for two-bolt mounting in any position.
- Pre-lubricated and ready for immediate installation.
- Grease fitting for relubrication.
- Premium Shaft Guarding Technology™ option reduces replacement time, provides shaft protection and prolongs the life of the shaft.
- Contact your Timken engineer to discuss highly corrosive applications (food processing, chemical exposure) where Timken thin-dense chrome-coated bearings can be utilized.

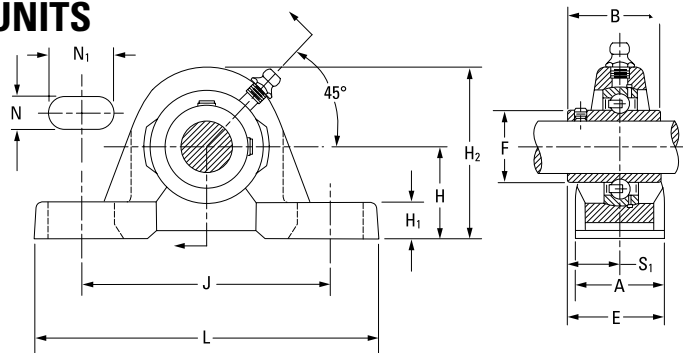

BEARING DATA

Suggested shaft tolerances:

1/2 in. – 1 15/16 in., nominal to -0.013 mm, -0.0005 in.;
2 in. – 2 15/16 in., nominal to -0.025 mm, -0.0010 in.

To order bearing with Shaft Guarding Technology™, specify bearing number followed by "SGT". Example: YAS 1 1/2 SGT

Unit	Bearing No.	Dimensions and Load Ratings
YAS	GY-KRRB	Page 46

Unit	Shaft Dia. in. mm	H		H ₂		B		L		J		A		H ₁		N		N ₁		F		S ₁		E		Bolt Size mm in.	Bearing No.	Housing No.	Unit Wt. kg lbs.
		mm	in.	mm	in.	mm	in.	mm	in.	mm	in.	mm	in.	mm	in.	mm	in.	mm	in.	mm	in.	mm	in.	mm	in.				
YAS	1/2	30.18	56.4	27.4	123.8	92.1	30.2	11.9	11.1	22.2	22.9	15.9	31.0	10	3/8	GY1008KRRB GY1010KRRB GYE17KRRB	AS 40MM	0.4536 1.0000											
YAS ⁽¹⁾	5/8	33.35	65.9	30.9 ⁽²⁾	127.0	96.4	33.3	15.1	11.2	20.2	27.56	18.3 ⁽²⁾	34.9 ⁽²⁾	10	3/8	GY1012KRRB ⁽¹⁾ GYE20KRRB ⁽¹⁾	ASR 47MM	0.7027 1.5491											
YAS ⁽¹⁾	7/8	36.53	73.0	34.1 ⁽²⁾	139.7	104.8	37.3	15.1	11.2	20.6	33.8	19.8 ⁽²⁾	38.5 ⁽²⁾	10	3/8	GY1014KRRB ⁽¹⁾ GY1015KRRB ⁽¹⁾ GY1100KRRB ⁽¹⁾ GYE25KRRB ⁽¹⁾	ASR 52MM	0.9535 2.1022											
YAS ⁽¹⁾	1 1/16	42.88	84.9	38.1 ⁽³⁾	157.2	117.3	42.9	16.7	14.3	23.8	40.3	22.2 ⁽³⁾	43.7 ⁽³⁾	12	1/2	GY1102KRRB ⁽¹⁾ GY1103KRRB ⁽¹⁾ GY1103KRRB3 GYE30KRRB ⁽¹⁾	ASR 62MM	1.4275 3.1472											
YAS ⁽¹⁾	1 1/8	47.63	95.3	42.9 ⁽⁴⁾	166.7	130.2	46.7	18.3	14.3	24.6	46.8	25.4 ⁽⁴⁾	48.8 ⁽⁴⁾	12	1/2	GY1104KRRB ⁽¹⁾ GY1106KRRB ⁽¹⁾ GY1107KRRB ⁽¹⁾ GYE35KRRB ⁽¹⁾	ASR 72MM	1.8981 4.1847											
YAS ⁽¹⁾	1 3/16	49.23	101.6	49.2	179.3	136.7	51.6	19.1	14.3	24.6	52.3	30.2	56.0	12	1/2	GY1108KRRB ⁽¹⁾ GYE40KRRB ⁽¹⁾	ASR 80MM	2.4763 5.4592											
YAS ⁽¹⁾	1 1/4	53.98	104.8	49.2	179.4	137.3	47.6	23.8	14.3	26.2	52.3	30.2	54.0	12	1/2	GY1108KRRB ⁽¹⁾	AS 80MM HIGH	2.2679 5.0000											
YAS ⁽¹⁾	1 1/2	53.98	106.4	49.2 ⁽⁵⁾	191.3	149.2	52.4	19.1	14.3	28.6	57.9	30.2 ⁽⁵⁾	56.4 ⁽⁵⁾	12	1/2	GY1110KRRB ⁽¹⁾ GY1111KRRB ⁽¹⁾ GY1112KRRB ⁽¹⁾ GYE45KRRB ⁽¹⁾	ASR 85MM	2.681 5.9107											
YAS ⁽¹⁾	1 5/8	57.15	114.3	51.6	200.0	158.0	57.9	19.1	18.3	25.4	62.8	32.5	61.5	16	5/8	GY1115KRRB ⁽¹⁾ GYE50KRRB ⁽¹⁾ GY1115KRRB3	ASR 90MM	3.3136 7.3053											
YAS ⁽¹⁾	2	63.50	127.8	55.6	222.2	176.2	60.3	20.6	18.3	29.4	69.8	33.3	63.5	16	5/8	GY1200KRRB ⁽¹⁾ GY1203KRRB ⁽¹⁾ GYE55KRRB ⁽¹⁾	ASR 100MM	3.9009 8.6000											
YAS ⁽¹⁾	2 1/4	69.85	138.9	65.1	239.7	188.1	60.3	23.8	18.3	29.2	76.5	39.1	69.9	16	5/8	GY1204KRRB ⁽¹⁾ GY1207KRRB ⁽¹⁾ GYE60KRRB ⁽¹⁾	ASR 110MM	4.7718 10.5200											
YAS ⁽¹⁾	2 1/2	76.2	154.0	69.9	266.7	203.2	73.0	33.3	20.6	34.9	86.9	42.9	79.4	20	3/4	GY1211KRRB ⁽¹⁾	AK 125MM	7.5473 16.6390											
YAS ⁽¹⁾	2 3/4	82.55	164.3	77.8	269.9	215.9	69.9	25.4	22.2	31.8	91.9	44.5	79.4	20	3/4	GY1215KRRB ⁽¹⁾ GYE75KRRB ⁽¹⁾	AS 130MM	7.9197 17.4600											
YAS ⁽¹⁾	2 15/16	88.90	177.8	77.8	330.2	228.6	88.9	31.8	23.8	50.8	91.9	44.5	88.9	20	3/4	GY1215KRRB ⁽¹⁾	LAKH 130MM	8.4187 18.5600											

NOTE: Shaft diameter with an S = Smaller housing; Shaft diameter with an H = heavier housing.

⁽¹⁾Shaft Guard Technology available

⁽²⁾Inner Ring with SGT is wider by 0.737mm [0.029 in.]

⁽³⁾Inner Ring with SGT is wider by 1.016mm [0.040 in.]

⁽⁴⁾Inner Ring with SGT is wider by 2.540mm [0.100 in.]

⁽⁵⁾Inner Ring with SGT is wider by 1.143mm [0.045 in.]

MOUNTED BALL BEARINGS

CAST-IRON MOUNTED BEARINGS • VAS

VAS STANDARD SERIES

- Timken Fafnir VAS pillow blocks are similar in design and features, and equal in load-carrying capacity, to the VAK series.
- The slightly different base-to-center height dimension makes them interchangeable with certain other competitive designs.
- The units are prelubricated and ready for immediate installation.
- A grease fitting is provided for relubrication if required.

Suggested shaft tolerances:

1/2 in. – 1 15/16 in., nominal to -0.013 mm, -0.0005 in.;

2 in. – 2 3/16 in., nominal to -0.025 mm, -0.0010 in.

To order, specify UNIT and SHAFT DIAMETER.

Example: VAS 1 3/16 in.

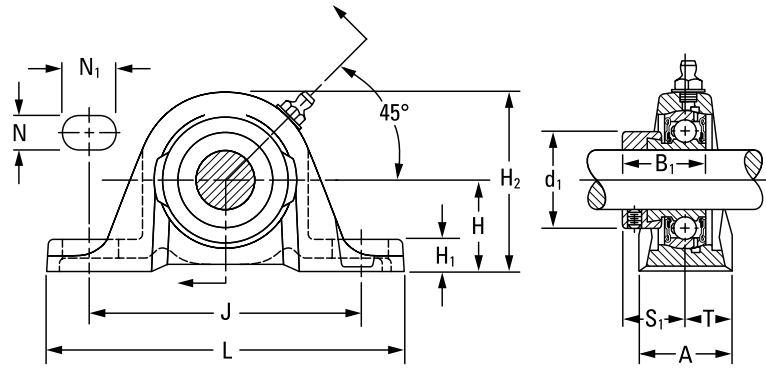

BEARING DATA

Unit	Bearing No.	Dimensions and Load Ratings
VAS	GRA-RRB	Page 52

Unit	Shaft Dia.	H	H ₂	B ₁	J	L	A	H ₁	N	N ₁	d ₁	S ₁	T	Bolt Size	Bearing No.	Collar No.	Housing No. New (Old)	Unit Wt.
																		kg lbs.
VAS	1/2														GRA008RRB	S1008K		
VAS	5/8	30.16	56.4	28.6	92.1	123.8	30.2	11.9	11.1	22.2	28.6	22.2	15.1	10	GRA010RRB	S1010K	Z955386 (T40238)	0.454
VAS	17	13/16	27/32	11/8	35/8	47/8	13/16	15/32	7/16	7/8	11/8	7/8	19/32	3/8	GRAE17RRB	SE17K		1.00
VAS	3/4	33.34	64.3	31.0	96.0	127.0	31.8	13.5	11.1	19.8	33.3	23.4	15.9	10	GRA012RRB	S1012K	Z955388 (T40239)	0.563
VAS	20	15/16	217/32	17/32	325/32	5	11/4	17/32	7/16	25/32	15/16	59/64	5/8	3/8	GRAE20RRB	SE20K		1.24
VAS	7/8														GRA014RRB	S1014K		
VAS	15/16	36.51	71.4	31.0	104.8	139.7	35.7	15.1	11.1	20.6	38.1	23.4	17.9	10	GRA015RRB	S1015K	Z955390 (T30365)	0.758
VAS	1	17/16	213/16	17/32	41/8	51/2	113/32	19/32	7/16	13/16	11/2	59/64	45/64	3/8	GRA100RRB	S1100K		1.67
VAS	25														GRAE25RRB	SE25K		
VAS	1 1/8														GRA102RRB	S1102K		
VAS	1 3/16	42.86	83.3	35.7	117.5	157.2	39.7	16.7	14.3	23.8	44.1	27.0	19.9	12	GRA103RRB	S1103K	Z955392 (T40241)	1.235
VAS	1 1/4 S	111/16	39/32	113/32	45/8	63/16	19/16	21/32	9/16	15/16	147/64	11/16	25/32	1/2	GRA103RRB2	S1103K3		2.72
VAS	30														GRAE30RRB	SE30K		
VAS	1 1/4														GRA104RRB	S1104K		
VAS	1 3/8	47.62	93.7	38.9	130.2	166.7	45.2	18.3	14.3	24.6	54.0	29.4	22.7	12	GRA106RRB	S1106K	Z955394 (T40242)	1.594
VAS	17/16	17/8	311/16	117/32	51/8	69/16	125/32	23/32	9/16	31/32	21/8	15/32	57/64	1/2	GRA107RRB	S1107K		3.51
VAS	35														GRAE35RRB	SE35K		
VAS	1 1/2	49.21	100.0	43.7	136.5	179.4	47.6	19.0	14.3	26.2	60.3	32.5	23.8	12	GRA108RRB	S1108KT	Z955396 (T40243)	2.034
VAS	40	115/16	315/16	123/32	53/8	71/16	17/8	3/4	9/16	11/32	23/8	19/32	15/16	1/2	GRAE40RRB	SE40K		4.48
VAS	1 5/8														GRA110RRB	S1110K		
VAS	1 11/16	53.98	106.4	43.7	149.2	191.3	50.8	19.0	14.3	28.6	63.5	32.5	25.4	12	GRA111RRB	S1111K	Z955397 (T40244)	2.261
VAS	13/4	21/8	43/16	123/32	57/8	717/32	2	3/4	9/16	11/8	21/2	19/32	1	1/2	GRA112RRB	S1112K		4.98
VAS	45														GRAE45RRB	SE45K		
VAS	1 7/8														GRA114RRB	S1114K		
VAS	1 15/16	57.15	114.3	43.7	158.0	200.0	55.6	19.0	18.3	29.4	69.8	32.5	27.8	16	GRA115RRB	S1115K	Z955399 (T40245)	2.774
VAS	2 S	21/4	41/2	123/32	67/32	77/8	23/16	3/4	23/32	15/32	23/4	19/32	13/32	5/8	GRA115RRB2	S1115K2		6.11
VAS	50														GRAE50RRB	SE50K		
VAS	2	63.50	126.2	48.4	176.2	222.3	58.7	20.6	18.3	29.4	76.2	36.5	29.4	16	GRA200RRB	S1200K	Z955401 (T40246)	3.328
VAS	2 3/16	21/2	431/32	129/32	615/16	83/4	25/16	13/16	23/32	15/32	3	17/16	15/32	5/8	GRA203RRB	S1203K		7.33
VAS	55														GRAE55RRB	SE55K		

NOTE: All units have 1/8 pipe-thread grease fitting except 1/2 – 15/16 and 3/4 units, which have 1/4-28 fitting.

SAS STANDARD SERIES

- The SAS is a streamlined and rugged one-piece pillow block unit that combines the Timken engineered housing and a GYA-RRB set screw bearing.
- GYA-RRB bearing employs a positive-contact, land-riding seal and specially designed set screws.
- SAS pillow block can be mounted in any position.
- Mounted bearings are factory-prelubricated, but a grease fitting is provided to allow for relubrication if required.

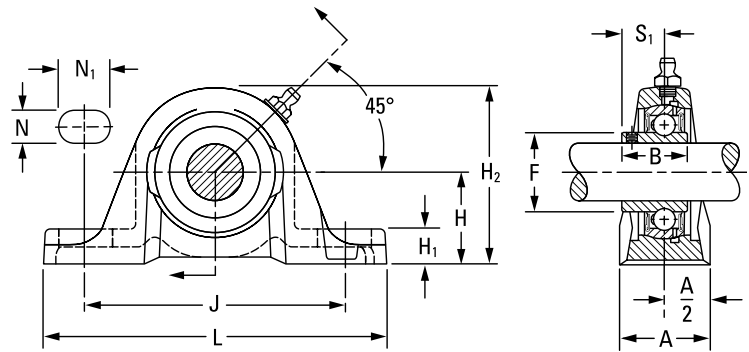

Suggested shaft tolerances:

1/2 in. – 1 15/16 in., nominal to -0.013 mm, -0.0005 in.;

2 in. – 2 3/16 in., nominal to -0.025 mm, -0.0010 in.

To order, specify UNIT and SHAFT DIAMETER.

Example: SAS 1 in.

BEARING DATA

Unit	Bearing No.	Dimensions and Load Ratings
SAS	GYA-RRB	Page 56

Unit	Shaft Dia.	Dimensions											Bolt Size	Bearing No.	Housing No. New (Old)	Unit Wt.
		H	H ₂	S ₁	J	L	A	H ₁	N	N ₁	F	B				
	in. mm	mm in.	mm in.	mm in.	mm in.	mm in.	mm in.	mm in.	mm in.	mm in.	mm in.	mm in.	mm in.	mm in.	mm in.	kg lbs.
SAS	1/2	30.16	56.4	15.9	92.1	123.8	30.2	11.9	11.1	22.2	24.6	23.8	10	GYA008RRB	Z955386 (T40238)	0.42
SAS	5/8	13/16	27/32	5/8	35/8	47/8	13/16	15/32	7/16	7/8	31/32	15/16	10	GYA010RRB		
SAS	17												3/8	GYAE17RRB		
SAS	3/4	33.34	64.3	18.3	96.0	127.0	31.8	13.5	11.1	19.8	29.0	27.0	10	GYA012RRB	Z955388 (T40239)	0.57
SAS	20	15/16	217/32	23/32	325/32	5	11/4	17/32	7/16	25/32	19/64	11/16	3/8	GYAE20RRB		
SAS	7/8	36.51	71.4	19.4	104.8	139.7	35.7	15.1	11.1	20.6	33.7	28.2	10	GYA014RRB	Z955390 (T30365)	0.75
SAS	15/16	17/16	213/16	49/64	41/8	51/2	113/32	19/32	7/16	13/16	121/64	17/64	10	GYA015RRB		
SAS	1												3/8	GYA100RRB		
SAS	25													GYAE25RRB		
SAS	1 1/8	42.86	83.3	23.0	117.5	157.2	39.7	16.7	14.3	23.8	40.1	32.5	12	GYA102RRB	Z955392 (T40241)	1.14
SAS	1 3/16	111/16	33/32	29/32	45/8	63/16	19/16	21/32	9/16	15/16	137/64	19/32	12	GYA103RRB		
SAS	1 1/4 S												1/2	GYA103RRB2		
SAS	30													GYAE30RRB		2.52
SAS	1 1/4	47.62	93.6	25.8	130.2	166.7	45.2	18.3	14.3	24.6	46.8	36.5	12	GYA104RRB	Z955394 (T40242)	1.52
SAS	1 3/8	17/8	311/16	11/64	51/8	69/16	129/32	23/32	9/16	31/32	127/32	17/16	12	GYA106RRB		
SAS	1 7/16												1/2	GYA107RRB		
SAS	35													GYAE35RRB		3.35
SAS	1 1/2	49.21	100.0	27.8	136.5	179.4	47.6	19.0	14.3	26.2	52.4	39.3	12	GYA108RRB	Z955396 (T40243)	1.85
SAS	40	115/16	315/16	13/32	53/8	71/16	17/8	3/4	9/16	11/32	21/16	135/64	1/2	GYAE40RRB		
SAS	1 1/2 H	53.90	100.0	27.8	136.5	179.4	47.6	19.0	14.3	26.2	52.4	39.3	12	GYA108RRB	Z956392 (T39258)	1.85
SAS	2 1/8												1/2			4.08
SAS	1 5/8	53.90	106.3	28.6	149.2	191.3	51.0	19.0	14.3	28.6	57.9	42.1	12	GYA110RRB	Z955397 (T40244)	2.06
SAS	1 11/16	21/8	43/16	11/8	57/8	717/32	2	3/4	9/16	11/8	29/32	121/32	12	GYA111RRB		
SAS	1 3/4												1/2	GYA112RRB		
SAS	45													GYAE45RRB		4.55
SAS	1 15/16	57.20	114.3	30.9	158.0	200.0	55.6	19.0	17.5	23.8	62.7	44.4	16	GYA115RRB	Z955399 (T40245)	2.54
SAS	2 S	21/4	41/2	17/32	67/32	77/8	23/16	3/4	11/16	15/16	215/32	13/4	16	GYA115RRB2		
SAS	50												5/8	GYAE50RRB		
SAS	2	63.50	126.2	31.7	176.2	222.3	58.7	20.6	18.3	29.4	69.8	46.4	16	GYA200RRB	Z955401 (T40246)	3.02
SAS	2 3/16	21/2	431/32	11/4	615/16	83/4	25/16	13/16	23/32	19/32	23/4	153/64	16	GYA203RRB		
SAS	55												5/8	GYAE55RRB		

NOTE: All units have 1/8 pipe-thread grease fitting except 1/2 – 11/16 and 3/4 units, which have 1/4-28 fitting.

NOTE: Shaft diameter with an S = smaller housing; Shaft diameter with an H = heavier housing.

RAKH INDUSTRIAL SERIES

- Timken Fafnir pillow blocks are similar in design to other standard series, but have slightly different dimensions to allow interchangeability with competitive designs.
- These pillow blocks may be used independently or in connection with the RAKHL expansion unit shown at right. Used in this capacity, the RAKH pillow blocks provide fixed shaft location while the RAKHL expansion units allow for axial movement. Maximum operating temperature for the RAKH units is 121° C (250° F).
- The units are supplied with self-locking collars.
- Contact your Timken engineer to discuss highly corrosive applications (food processing, chemical exposure) where Timken thin-dense chrome-coated bearings can be utilized.

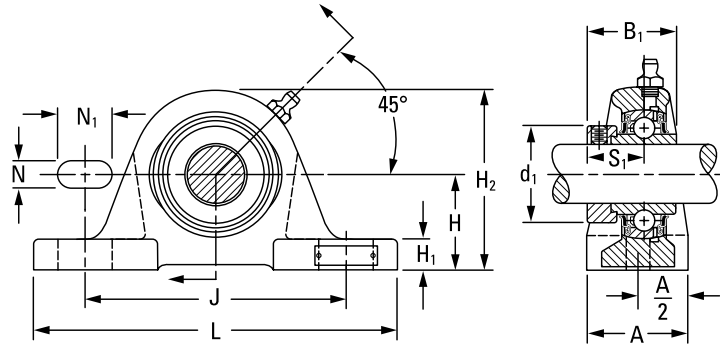

Suggested shaft tolerances:

- 1 3/16 in. – 1 15/16 in., nominal to -0.013 mm, -0.0005 in.;
- 2 in. – 2 15/16 in., nominal to -0.025 mm, -0.0010 in.

To order, specify UNIT and SHAFT DIAMETER.

Example: RAKH 1 7/16 in.

BEARING DATA

Unit	Bearing No.	Dimensions and Load Ratings
RAKH	G-KRRB	Page 36

Unit ⁽¹⁾	Shaft Dia.	H	H ₂	B ₁	J	L	A	H ₁	N	N ₁	d ₁	S ₁	Bolt Size	Bearing No.	Collar No.	Housing No. New (Old)	Unit Wt.
		in.	mm	in.	mm	in.	mm	in.	mm	in.	mm	in.					
RAKH	1 5/16	44.45	82.6	44.4	119.1	158.8	50.8	15.9	14.3	25.4	38.1	27.0	12	G1015KRRB	S1015K	Z956512 (T22295)	1.689
RAKH	1	1 3/4	3 1/4	1 3/4	4 11/16	6 1/4	2	5/8	9/16	1	1 1/2	1 1/16	1/2	G1100KRRB	S1100K		3.720
RAKH	1 3/16	47.63	90.5	48.4	127.0	174.6	57.2	17.5	14.3	25.4	44.1	30.2	12	G1103KRRB	S1103K	Z956541 (T90016)	2.184
RAKH	1 3/8	1 7/8	3 9/16	1 29/32	5	6 7/8	2 1/4	1 1/16	9/16	1	1 47/64	1 3/16	1/2				4.810
RAKH	1 1/4													G1104KRRB	S1104K		
RAKH	1 5/16	53.98	101.6	51.2	144.5	203.2	57.2	19.0	14.3	30.2	54.0	32.5	12	G1105KRRB	S1105K	Z955360 (T22212)	2.915
RAKH	1 3/8	2 1/8	4	2 1/64	5 11/16	8	2 1/4	3/4	9/16	1 3/16	2 1/8	1 9/32	1/2	G1106KRRB	S1106K		6.420
RAKH	1 7/16													G1107KRRB	S1107K		
RAKH	1 1/2	58.74	111.1	56.4	155.6	222.2	66.7	20.6	17.5	31.8	60.3	34.9	16	G1108KRRB	S1108KT	Z956508 (T22291)	4.004
RAKH	1 1/2	2 5/16	4 3/8	2 7/32	6 1/8	8 3/4	2 5/8	1 3/16	1 1/16	1 1/4	2 3/8	1 3/8	5/8				8.820
RAKH	1 11/16	58.74	114.3	56.4	155.6	222.2	66.7	20.6	17.5	33.3	63.5	34.9	16	G1111KRRB	S1111K	Z956513 (T22293)	4.032
RAKH	1 3/4	2 5/16	4 1/2	2 7/32	6 1/8	8 3/4	2 5/8	1 3/16	1 1/16	1 5/16	2 1/2	1 3/8	5/8	G1112KRRB	S1112K		8.880
RAKH	1 15/16	63.50	122.2	62.7	171.4	241.3	73.0	22.2	17.5	36.5	69.8	38.1	16	G1115KRRB	S1115K	Z956408 (T22214)	5.098
RAKH	50	2 1/2	4 13/16	2 15/32	6 3/4	9 1/2	2 7/8	7/8	1 1/16	1 7/16	2 3/4	1 1/2	5/8	GE50KRRB	SE50K		11.230
RAKH	2	69.85	136.5	71.4	184.2	260.4	79.4	27.0	20.6	36.5	76.2	43.7	16	G1200KRRB	S1200K	Z955356 (T22297)	6.728
RAKH	2 3/16	2 3/4	5 3/8	2 13/16	7 1/4	10 1/4	3 1/8	1 1/16	1 3/16	1 7/16	3	1 23/32	5/8	G1203KRRB	S1203K		14.820
RAKH	55													GE55KRRB	SE55K		
RAKH	2 7/16	76.20	150.8	77.8	203.2	285.8	82.6	27.0	20.6	41.3	84.1	46.8	16	G1207KRRB	S1207K	Z955357 (T22299)	8.2170
RAKH	60	3	5 15/16	3 1/16	8	11 1/4	3 1/4	1 1/16	1 3/16	1 5/8	3 5/16	1 27/32	5/8	GE60KRRB	SE60K		18.115
RAKH	2 11/16	88.90	171.4	85.7	228.6	330.2	88.9	28.6	23.8	50.8	96.8	45.2	20	G1211KRRB	S1211K	Z956571 (T22303)	11.495
RAKH	2 11/16	3 1/2	6 3/4	3 3/8	9	13	3 1/2	1 1/8	1 5/16	2	3 13/16	1 25/32	3/4				25.320
RAKH	2 15/16	88.90	177.8	92.1	228.6	330.2	88.9	31.8	23.8	50.8	101.6	54.8	20	G1215KRRB	S1215K	Z956471 (T22305)	11.795
RAKH	2 15/16	3 1/2	7	3 5/8	9	13	3 1/2	1 1/4	1 5/16	2	4	2 5/32	3/4				25.980

⁽¹⁾When used with the expansion unit, specify both units, shaft diameter and suffix.

RAKHL EXPANSION SERIES

- The RAKH expansion series is designed to allow axial shaft expansion caused by elevated temperatures or other conditions that lead to shaft movement.
- The RAKH expansion-series bearings are designed for use with the RAKH pillow blocks.
- RAKH units provide axial shaft location and the RAKHL allows shaft floatation.
- Due to limitations of the lubricant and seal material, the maximum operating temperature for the RAKHL units is 121° C (250° F).
- Units are supplied with self-locking collars.
- Steel S-ring ensures axial expansion.

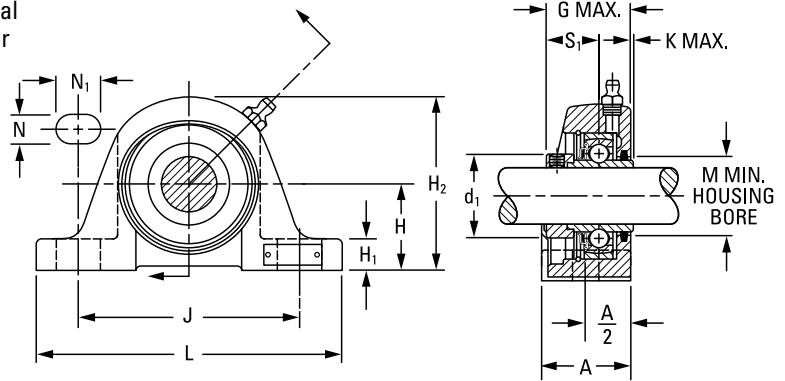

Suggested shaft tolerances:

- 1 3/16 in. – 1 15/16 in., nominal to -0.013 mm, -0.0005 in.;
- 2 in. – 2 15/16 in., nominal to -0.025 mm, -0.0010 in.

To order, specify UNIT and SHAFT DIAMETER.

Example: RAKHL 2 7/16 in.

BEARING DATA

Unit	Bearing No.	Dimensions and Load Ratings
RAKHL	KRS	Page 45

Unit	Shaft Dia.	Total Float	H	H ₂	G	J	L	A	H ₁	N	N ₁	K	d ₁	S ₁	M	Bolt Size	Bearing No.	Collar No.	Housing No. New (Old)	Unit Wt. kg lbs.
RAKHL	1 3/16	3.2 1/8	47.63 1 7/8	96.8 3 13/16	49.2 1 15/16	127.0 5	174.6 6 7/8	50.8 2	17.5 11/16	14.3 9/16	25.4 1	2.4 3/32	44.5 1 3/4	30.2 1 3/16	41.70 1 41/64	12 1/2	1103KRS	S1103K	Z956573 (A11414)	2.182 4.81
RAKHL	1 3/8	4.8 3/16	53.98 2 1/8	106.4 4 3/16	55.2 2 11/64	144.5 5 11/16	201.6 7 15/16	51.6 2 1/32	19.0 3/4	14.3 9/16	30.2 1 3/16	3.2 1/8	54.0 2 1/8	32.5 1 9/32	48.02 1 57/64	12 1/2	1106KRS 1107KRS	S1106K S1107K	Z955338 (A11199)	2.912 6.42
RAKHL	1 15/16	6.4 1/4	63.50 2 1/2	129.4 5 3/32	65.1 2 9/16	171.4 6 3/4	241.3 9 1/2	63.5 2 1/2	22.2 7/8	17.5 1 1/16	36.5 1 7/16	4.0 5/32	69.8 2 3/4	38.1 1 1/2	63.90 2 33/64	16 5/8	1115KRS	S1115K	Z956535 (A11357)	5.094 11.23
RAKHL	2 3/16	6.4 1/4	69.85 2 3/4	142.9 5 5/8	73.4 2 57/64	184.2 7 1/4	260.4 10 1/4	76.2 3	27.0 1 1/16	20.6 1 3/16	36.5 1 7/16	4.4 11/64	76.2 3	43.7 1 23/32	71.00 2 51/64	16 5/8	1203KRS	S1203K	Z956503 (A11358)	6.722 14.82
RAKHL ⁽¹⁾	2 7/16	6.4 1/4	76.20 3	158.8 6 1/4	78.6 3 3/32	203.2 8	285.8 11 1/4	82.6 3 1/4	27.0 1 1/16	20.6 1 3/16	41.3 1 5/8	4.8 3/16	84.1 3 5/16	46.8 1 27/32	78.20 3 5/64	16 5/8	1207KRS	S1207K	-	8.210 18.10
RAKHL	2 15/16	6.4 1/4	88.90 3 1/2	181.0 7 1/4	113.5 3 15/32	228.6 9	330.2 13	88.9 3 1/2	31.8 1 1/4	23.8 1 5/16	50.8 2	8.7 1 1/32	101.6 4	54.8 2 5/32	118.70 3 43/64	20 3/4	1215KRS	S1215K	Z956575 (T28261)	11.785 25.98

⁽¹⁾Special order.

YASM MEDIUM-DUTY SERIES SET SCREW LOCK

- Timken Fafnir YASM medium-duty pillow blocks feature the GYM-KRRB bearing inserts.
- Timken Fafnir YASM medium-duty pillow blocks are ideal for conveyor, fan and blower, sawmill, and feed and grain handling applications.
- The cast-iron housings are durable, powder-coated and maintain an excellent finish, while resisting corrosion, chemicals and weather exposure.
- These pillow blocks incorporate premium features designed to extend bearing life.

Suggested shaft tolerances:

- 1 in. – 1 15/16 in., nominal to -0.013 mm, -0.0005 in.;
- 2 in. – 3 in., nominal to -0.025 mm, -0.0010 in.

To order, specify UNIT and SHAFT DIAMETER.

Example: YASM 1 7/16 in.

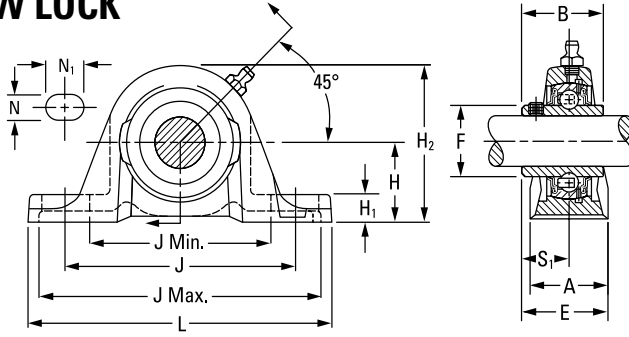

BEARING DATA

Unit	Bearing No.	Dimensions and Load Ratings
YASM	GYM-KRRB	Page 58

Unit	Shaft Dia.	H	H ₂	B	L	J	J min.	J max.	A	H ₁	F	N	N ₁	S ₁	E	Bolt Size	Bearing No.	Housing No. New (Old)
	in.	mm in.	mm in.	mm in.	mm in.	mm in.	mm in.	mm in.	mm in.	mm in.	mm in.	mm in.	mm in.	mm in.	mm in.	mm in.		
YASM	1	42.86	83.30	38.10	157.2	117.5	93.70	141.30	39.70	16.70	40.31	14.22	23.88	22.20	42.070	12	GYM1100KRRB	Z955392
YASM	1 SGT	1 1/16	3 3/32	1 1/2	6 3/16	4 9/8	3 11/16	5 9/16	1 9/16	2 1/32	1.587	9/16	15/16	7/8	1 21/32	1/2	GYM1100KRRB SGT	(T40241)
YASM	1 3/16	47.62	93.60	42.90	166.7	130.2	105.60	154.80	45.20	18.30	48.84	14.22	24.64	25.40	48.020	12	GYM1103KRRB	Z955394
YASM	1 3/16 SGT	1 7/8	3 11/16	1 11/16	6 9/16	5 1/8	4 5/32	6 3/32	1 25/32	2 3/32	1.844	9/16	31/32	1	1 57/64	1/2	GYM1103KRRB SGT	(T40242)
YASM	1 7/16	53.98	104.80	49.20	179.4	136.5	110.30	162.70	47.60	23.00	52.27	14.22	26.16	30.20	53.980	12	GYM1107KRRB	Z956392
YASM	1 7/16 SGT	2 1/8	4 1/8	1 15/16	7 1/16	5 3/8	4 11/32	6 13/16	1 7/8	2 9/32	2.058	9/16	1 1/32	1 3/16	2 1/8	1/2	GYM1107KRRB SGT	(T39258)
YASM	1 1/2	53.98	106.30	49.20	191.3	149.2	120.70	177.80	50.80	19.10	57.92	14.22	28.45	30.20	55.560	12	GYM1108KRRB	Z955397
YASM	1 1/2 SGT	2 1/8	4 3/16	1 15/16	7 11/32	5 7/8	4 3/4	7	2	3/4	2.280	9/16	1 1/8	1 3/16	2 3/16	1/2	GYM1108KRRB SGT	(T40244)
YASM	1 11/16	57.15	114.30	51.60	200.0	157.9	134.10	183.40	55.60	19.10	62.84	17.53	23.88	32.50	60.330	16	GYM1111KRRB	Z955399
YASM	1 11/16 SGT	2 1/4	4 1/2	2 1/32	7 7/8	6 1/32	5 9/32	7 5/32	2 3/16	3/4	2.474	11/16	15/16	1 9/32	2 3/8	5/8	GYM1111KRRB SGT	(T402459)
YASM	1 3/4																GYM1112KRRB	
YASM	1 15/16																GYM1115KRRB	
YASM	1 15/16 SGT	63.50	126.20	55.60	222.3	176.2	146.90	205.60	54.80	20.60	69.77	18.26	29.46	33.30	61.910	16	GYM1111KRRB SGT	Z955401
YASM	2	2 1/2	4 31/32	2 3/16	8 3/4	6 15/16	5 25/32	8 3/32	2 5/32	1 3/16	2.747	23/32	1 5/32	1 5/16	2 7/16	5/8	GYM1200KRRB	(T40246)
YASM	2 SGT																GYM1200KRRB SGT	
YASM	2 3/16																GYM1203KRRB	
YASM	2 3/16 SGT	69.85	138.90	65.10	239.7	188.1	158.80	217.50	60.30	23.80	76.48	18.26	29.46	39.10	69.850	16	GYM1203KRRB SGT	Z955353
YASM	2 1/4	2 3/4	5 15/32	2 9/16	9 7/16	7 13/32	6 1/4	8 9/16	2 3/8	1 5/16	3.011	23/32	1 5/32	1 9/16	2 3/4	5/8	GYM1204KRRB	(T40247)
YASM	2 1/4 SGT																GYM1204KRRB SGT	
YASM	2 7/16																GYM1207KRRB	
YASM	2 7/16 SGT	76.20	153.99	77.78	266.7	203.2	168.28	238.13	73.02	33.34	86.92	20.57	35.05	42.86	79.375	20	GYM1207KRRB SGT	Z955326
YASM	2 1/2	3	6 1/16	3 1/16	10 1/2	8	6 5/8	9 3/8	2 7/8	1 5/16	3.422	13/16	1 3/8	1 11/16	3 1/8	3/4	GYM1208KRRB	(T22503)
YASM	2 1/2 SGT																GYM1208KRRB SGT	
YASM	2 11/16	88.90	177.80	93.66	330.2	228.6	177.80	279.40	88.90	31.75	91.90	23.88	50.08	44.45	93.660	20	GYM1211KRRB	Z956471
YASM	2 11/16 SGT	3 1/2	7	3 11/16	13	9	7	11	3 1/2	1 1/4	3.618	15/16	2	1 3/4	3 11/16	3/4	GYM1211KRRB SGT	(T22305)
YASM	2 15/16																GYM1215KRRB	
YASM	2 15/16 SGT	88.90	177.80	93.66	330.2	228.6	177.80	279.40	88.90	31.75	91.90	23.88	50.08	44.45	93.660	20	GYM1215KRRB SGT	Z956388
YASM	3	3 1/2	7	3 11/16	13	9	7	11	3 1/2	1 1/4	3.618	15/16	2	1 3/4	3 11/16	3/4	GYM1300KRRB	(T90058)
YASM	3 SGT																GYM1300KRRB SGT	
YASM	3 7/16	101.60	209.55	96.04	381.0	282.58	222.25	342.90	111.10	33.34	111.92	23.81	60.33	56.36	111.919	20	GYM1307KRRB	Z956522
YASM	3 7/16 SGT	4	8 1/4	3 25/32	15	11 1/8	8 3/4	13 1/2	4 3/8	1 15/16	4 13/32	15/16	2 3/8	2 7/32	4 13/32	3/4	GYM1307KRRB SGT	(M81157)
YASM	3 15/16	127.00	254.00	117.48	431.8	336.55	276.23	396.90	114.30	33.34	131.37	28.58	63.50	68.26	125.413	24	GYM1315KRRB	Z956516
YASM	3 15/16 SGT	5	10	4 5/8	17	13 1/4	10 7/8	15 5/8	4 1/2	1 15/16	5 11/64	1 1/8	2 1/2	2 11/16	4 15/16	1	GYM1315KRRB SGT	(M81154)

STB SERIES

- STB mounted two-bolt bearings come assembled and ready for mounting.
- These mounted bearings are ideal for applications where space is limited, bolt screws are accessed from the bottom of the unit, loads are not severe and reversing moments do not occur.
- The units are assembled with GYA-RRB bearings with positive-contact, land-riding seals and set screw locking.
- The units are factory-prelubricated, but a grease fitting is provided for relubrication if required.

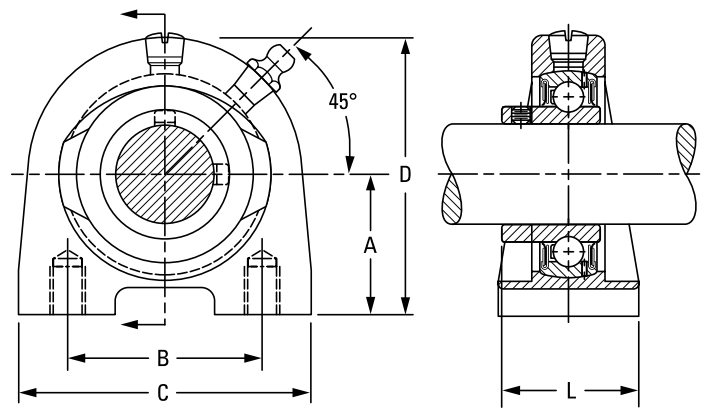

To order, specify UNIT and SHAFT DIAMETER.

Example: STB 1 in.

BEARING DATA

Unit	Bearing No.	Dimensions and Load Ratings
STB	GYA-RRB	Page 56

Unit	Shaft Dia.	Dimensions and Load Ratings								Bearing No.	Housing No. New (Old)
		A	B	C	D	F	H	N	L		
	in. mm	mm in.	mm in.	mm in.	mm in.	mm in.	mm in.	mm in.	mm in.		
STB	3/4	33.3	50.80	73.03	61.12	18.30	36.50	3/8-16	36.50	GYA012RRB	Z956554 (T90000)
STB	20	1 5/16	2	2 7/8	2 13/32	23/32	1 7/16		1 7/16	GYAE20RRB	
STB	7/8	36.5	50.80	76.20	71.44	18.30	36.50	3/8-16	37.70	GYA014RRB	Z955307 (T39312)
STB	15/16										
STB	1	1 7/16	2	3	2 13/16	23/32	1 7/16		1 31/64	GYA015RRB	
STB	25									GYA100RRB	
										GYAE25RRB	
STB	1 1/8	42.9	76.20	101.60	82.60	19.05	38.10	7/16-14	42.07	GYA102RRB	Z955320 (T90002)
STB	1 3/16										
STB	1 1/4 S	1 11/16	3	4	3 1/4	3/4	1 1/2		1 21/32	GYA103RRB	
STB	30									GYA103RRB2	
										GYAE30RRB	
STB	1 1/4	47.6	82.60	107.95	93.66	22.23	44.45	1/2-13	48.02	GYA104RRB	Z955306 (T39313)
STB	1 3/8										
STB	1 7/16	1 7/8	3 1/4	4 1/4	3 11/16	7/8	1 3/4		1 57/64	GYA106RRB	
STB	35									GYA107RRB3	
										GYAE35RRB	
STB	1 1/2	49.2	88.90	117.48	100.01	23.81	47.63	1/2-13	51.20	GYA108RRB	Z956592 (T90005)
STB	40										
		1 15/16	3 1/2	4 5/8	3 15/16	15/16	1 7/8		2 1/64	GYAE40RRB	
STB	1 5/8	54.0	95.25	127.00	107.95	25.40	50.80	1/2-13	53.98	GYA110RRB	T90008
STB	1 11/16										
STB	1 3/4	2 1/8	3 3/4	5	4 1/4	1	2		2 1/8	GYA111RRB	
STB	45									GYA112RRB	
										GYAE45RRB	
STB	1 15/16	57.2	101.60	139.70	118.90	25.40	50.80	5/8-11	56.36	GYA115RRB	T90010
STB	2										
STB	50	2 1/4	4	5 1/2	4 11/16	1	2		2 7/32	GYA200RRB	
										GYAE50RRB	

NOTE: Shaft diameter with an S = Smaller housing; Shaft diameter with an H = heavier housing.

⁽¹⁾Shaft Guard Technology available

⁽²⁾Inner Ring with SGT is wider by 0.737mm [0.029 in.]

⁽³⁾Inner Ring with SGT is wider by 1.016mm [0.040 in.]

⁽⁴⁾Inner Ring with SGT is wider by 2.540mm [0.100 in.]

⁽⁵⁾Inner Ring with SGT is wider by 1.143mm [0.045 in.]

YTB SERIES

- YTB mounted two-bolt bearings come assembled and ready for mounting.
- These mounted bearings are ideal for applications where space is limited, bolt screws are accessed from the bottom of the unit, loads are not severe and reversing moments do not occur.
- The units are assembled with GY-KRRB bearings with positive-contact, land-riding seals and set screw locking.
- The units are factory-prelubricated, but a grease fitting is provided for relubrication if required.

Suggested shaft tolerances:

- 1/2 in. – 1 15/16 in., nominal to -0.013 mm, -0.0005 in.;
- 2 in. – 2 15/16 in., nominal to -0.025 mm, -0.0010 in.

To order, specify UNIT and SHAFT DIAMETER.

Example: YTB 1

To order bearing with Shaft Guarding Technology™, specify bearing number followed by "SGT".

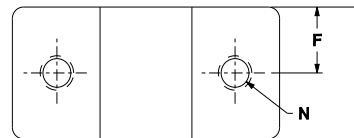
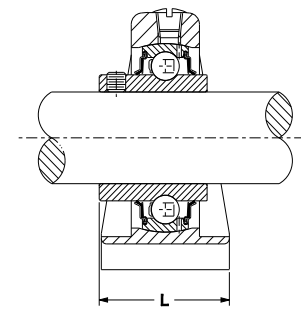
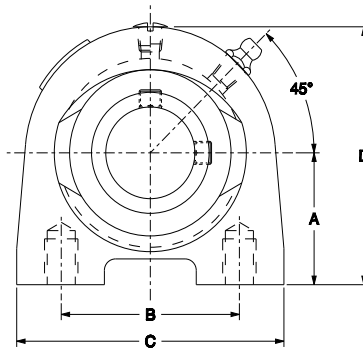

BEARING DATA

Unit	Bearing No.	Dimensions and Load Ratings
YTB	GY-KRRB	Page 46

Unit	Shaft Dia.	Dimensions								Bearing No.	Housing No.	Unit Wt.
		A	B	C	D	F	H	N	L			
	in. mm	mm in.	mm in.	mm in.	mm in.	mm in.	mm in.	mm in.	mm in.			kg lbs.
YTB	3/4	33.3	50.80	73.03	61.12	18.30	36.50	3/8-16 in.	36.53 ⁽²⁾	GY1012KRRB ⁽¹⁾	TB 47MM	0.60
YTB	20	1 5/16	2	2 7/8	2 13/32	23/32	1 7/16		1 7/16	GYE20KRRB ⁽¹⁾		1.4
YTB	7/8	36.5	50.80	76.20	71.44	18.30	36.50	3/8-16 in.	38.10 ⁽²⁾	GY1014KRRB ⁽¹⁾	TB 52MM	0.80
YTB	15/16	1 7/16	2	3	2 13/16	23/32	1 7/16		1 1/2	GY1015KRRB ⁽¹⁾		1.7
YTB	1	42.9	76.20	101.60	82.60	19.05	38.10	7/16-14 in.	41.28 ⁽³⁾	GY1100KRRB ⁽¹⁾	TB 62MM	1.34
YTB	25	1 11/16	3	4	3 1/4	3/4	1 1/2		1 5/8	GY1103KRRB ⁽¹⁾		3.0
YTB	1 1/8	47.6	82.60	107.95	93.66	22.23	44.45	1 3/4 1/2-13 in.	47.63 ⁽⁴⁾	GY1104KRRB ⁽¹⁾	TB 72MM	1.80
YTB	1 3/16	1 7/8	3 1/4	4 1/4	3 11/16	7/8	1 7/8		1 7/8	GY1106KRRB ⁽¹⁾		4.0
YTB	1 1/4	49.2	88.90	117.48	100.01	23.81	47.63	1 7/8 1/2-13 in.	54.00	GY1107KRRB ⁽¹⁾	TB 80MM	2.20
YTB	30	1 15/16	3 1/2	4 5/8	3 15/16	15/16	2 1/8		2 1/8	GYE35KRRB ⁽¹⁾		4.8
YTB	1 5/8	54.0	95.25	127.00	107.95	25.40	50.80	2 1/2-13 in.	55.58 ⁽⁵⁾	GY1108KRRB ⁽¹⁾	TB 85MM	2.70
YTB	40	2 1/8	3 3/4	5	4 1/4	1	2		2 3/16	GY1110KRRB ⁽¹⁾		5.9
YTB	1 11/16	57.2	101.60	139.70	118.90	25.40	50.80	2 5/8-11 in.	32.54	GY1111KRRB ⁽¹⁾	TB 90MM	3.10
YTB	45	2 1/4	4	5 1/2	4 11/16	1	2		1 9/32	GY1112KRRB ⁽¹⁾		6.8
YTB	1 15/16									GY1115KRRB ⁽¹⁾		
YTB	2 S									GY1115KRRB3		
YTB	50									GYE50KRRB ⁽¹⁾		

NOTE: Shaft diameter with an S = smaller housing.

⁽¹⁾Shaft Guard Technology available

⁽²⁾Inner Ring with SGT is wider by 0.737mm [0.029 in.]

⁽³⁾Inner Ring with SGT is wider by 1.016mm [0.040 in.]

⁽⁴⁾Inner Ring with SGT is wider by 2.540mm [0.100 in.]

⁽⁵⁾Inner Ring with SGT is wider by 1.143mm [0.045 in.]

VTB SERIES

- VTB mounted two-bolt bearings are nearly identical to the STB unit, except they are assembled with the GRA-RRB bearings and positive-contact R-seals and locking collar.

To order, specify UNIT and SHAFT DIAMETER.

Example: VTB 1 in.

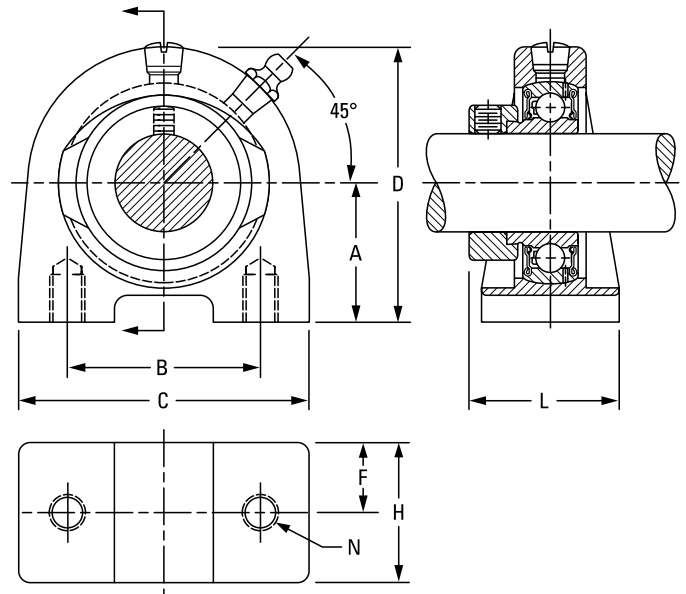

BEARING DATA

Unit	Bearing No.	Dimensions and Load Ratings
VTB	GRA-RRB	Page 52

Unit	Shaft Dia.	Dimensions								Bearing No.	Collar No.	Housing No. New (Old)
		A	B	C	D	F	H	N	L			
	in. mm	mm in.	mm in.	mm in.	mm in.	mm in.	mm in.	mm in.	mm in.			
VTB	3/4	33.3	50.80	73.03	61.12	18.30	36.50	3/8-16	41.67	GRA012RRB	S1012K	Z956554
VTB	20	1 5/16	2	2 7/8	2 13/32	23/32	1 7/16		1 41/64	GRAE20RRB	SE20K	(T90000)
VTB	7/8									GRA014RRB	S1014K	
VTB	15/16	36.5	50.80	76.20	71.44	18.30	36.50	3/8-16	41.67	GRA015RRB	S1015K	Z955307
VTB	1	1 7/16	2	3	2 13/16	23/32	1 7/16		1 41/64	GRA100RRB	S1100K C2	(T39312)
VTB	25									GRAE25RRB	SE25K	
VTB	1 1/8									GRA102RRB	S1102K	
VTB	1 3/16	42.9	76.20	101.60	82.60	19.05	38.10	7/16-14	45.64	GRA103RRB	S1103K	Z955320
VTB	1 1/4 S	1 11/16	3	4	3 1/4	3/4	1 1/2		1 51/64	GRA103RRB2	S1103K3	(T90002)
VTB	30									GRAE30RRB	SE30K	
VTB	1 1/4									GRA104RRB	S1104K C1	
VTB	1 3/8	47.6	82.60	107.95	93.66	22.23	44.45	1/2-13	51.60	GRA106RRB	S1106K C1	Z955306
VTB	1 7/16	1 7/8	3 1/4	4 1/4	3 11/16	7/8	1 3/4		2 1/32	GRA107RRB3	S1107K C1	(T39313)
VTB	35									GRAE35RRB	SE35K	
VTB	1 1/2	49.2	88.90	117.48	100.01	23.81	47.63	1/2-13	56.36	GRA108RRB	S1108KT	Z956592
VTB	40	1 15/16	3 1/2	4 5/8	3 15/16	15/16	1 7/8		2 7/32	GRAE40RRB	SE40K	(T90004)
VTB	1 5/8									GRA110RRB	S1110K	
VTB	1 11/16	54.0	95.25	127.00	107.95	25.40	50.80	1/2-13	57.94	GRA111RRB	S1111K	T90007
VTB	1 3/4	2 1/8	3 3/4	5	4 1/4	1	2		2 9/32	GRA112RRB	S1112K	
VTB	45									GRAE45RRB	SE45K	
VTB	1 15/16									GRA115RRB	S1115K	
VTB	2 S	57.2	101.60	139.70	118.90	25.40	50.80	5/8-11	57.94	GRA115RRB2	S1115K2	T90009
VTB	50	2 1/4	4	5 1/2	4 11/16	1	2		2 9/32	GRAE50RRB	SE50K	

NOTE: Shaft diameter with an S = smaller housing.

RAO, LAO HEAVY SERIES

- This is a compact, economic, mounted heavy-duty ball bearing.
- This series incorporates the tested and proven features of the Timken Fafnir standard RAK-series pillow block.
- RAO-series bearings are equipped to handle heavy capacity.
- LAO-series bearings are equipped with heavy-series GN-KLLB wide-inner-ring ball bearings.
- The units are supplied with a self-locking collar that eliminates shaft shoulders, machining adapters and sleeves, and locknuts that provide easy mounting.

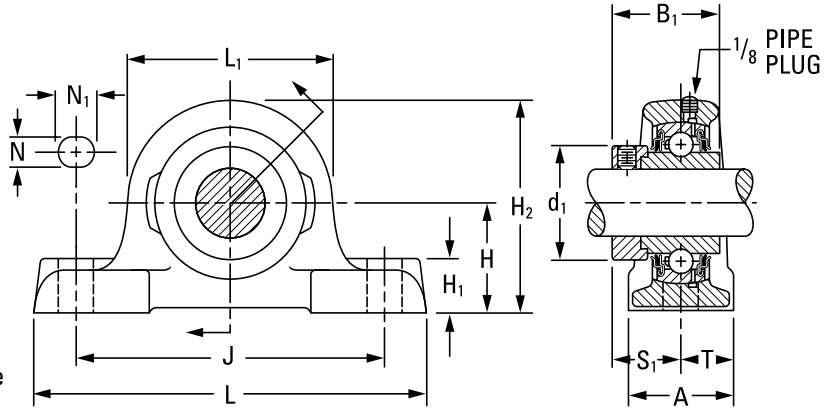

Suggested shaft tolerances:

- 1 3/16 in. – 1 15/16 in., nominal to -0.013 mm, -0.0005 in.;
- 2 in. – 2 15/16 in., nominal to -0.025 mm, -0.0010 in.

To order, specify UNIT and SHAFT DIAMETER.

Example: RAO 1 7/16 in.

BEARING DATA

Unit	Bearing No.	Dimensions and Load Ratings
RAO	GN-KRRB	Page 59
LAO	GN-KLLB	Page 61

Unit ⁽¹⁾	Shaft Dia.	H	H ₂	B ₁	L ₁	J	L	A	H ₁	N	N ₁	d ₁	S ₁	T	Bolt Size	Bearing No.	Collar No.	Housing No. New (Old)	Unit Wt.
		mm in.	mm in.	mm in.	mm in.	mm in.	mm in.	mm in.	mm in.	mm in.	mm in.	mm in.	mm in.	mm in.					
RAO	1 3/16	47.63 1 7/8	93.7 3 11/16	50.0 1 31/32	90.5 3 9/16	136.5 5 3/8	173.0 6 13/16	49.2 1 15/16	22.2 7/8	15.9 5/8	19.0 3/4	49.2 1 15/16	32.5 1 9/32	24.6 31/32	12 1/2	GN103KRRB	SN103K	Z955359 (T18798)	1.898 4.18
RAO	1 1/4															GN104KRRB	SN104K		
RAO	1 3/8	53.98 2 1/8	104.0 4 3/32	51.6 2 1/32	101.6 4	152.4 6	192.1 7 9/16	54.0 2 1/8	23.8 15/16	15.9 5/8	19.0 3/4	55.6 2 3/16	33.3 1 5/16	27.0 1 1/16	12 1/2	GN106KRRB	SN106K	Z955327 (T18626)	2.406 5.30
RAO	1 7/16															GN107KRRB	SN107K		
RAO	1 1/2	60.33 2 3/8	117.5 4 5/8	57.2 2 1/4	114.3 4 1/2	171.4 6 3/4	215.9 8 1/2	60.3 2 3/8	27.0 1 1/16	19.0 3/4	25.4 1	63.5 2 1/2	37.3 1 15/32	30.2 1 3/16	16 5/8	GN108KRRB	SN108K	Z956509 (T18800)	3.755 8.27
RAO	1 11/16	66.68 2 5/8	130.2 5 1/8	58.7 2 5/16	127.0 5	190.5 7 1/2	239.7 9 7/16	66.7 2 5/8	30.2 1 3/16	19.0 3/4	25.4 1	69.8 2 3/4	38.9 1 17/32	33.3 1 5/16	16 5/8	GN111KRRB	SN111K	Z955334 (T18802)	5.030 11.08
RAO	1 3/4															GN112KRRB	SN112K		
RAO	1 15/16	71.44 2 13/16	141.3 5 9/16	66.7 2 5/8	138.1 5 7/16	209.6 8 1/4	265.1 10 7/16	73.0 2 7/8	33.3 1 5/16	19.0 3/4	25.4 1	76.2 3	42.1 1 21/32	36.5 1 7/16	16 5/8	GN115KRRB	SN115K	Z955336 (T18804)	6.265 13.80
RAO	2															GN200KRRB	SN200K		
RAO	2 3/16	77.79 3 1/16	153.2 6 1/32	73.0 2 7/8	150.8 5 15/16	228.6 9	287.3 11 5/16	79.4 3 1/8	36.5 1 7/16	22.2 7/8	28.6 1 1/8	82.6 3 1/4	45.2 1 25/32	39.7 1 9/16	20 3/4	GN203KRRB	SN203K	Z955318 (T18806)	7.940 17.49
RAO	55															GNE55KRRB	SNE55K		
RAO	2 7/16	84.14 3 5/16	165.9 6 17/32	79.4 3 1/8	163.5 6 7/16	247.6 9 3/4	312.7 12 5/16	84.1 3 5/16	38.1 1 1/2	22.2 7/8	28.6 1 1/8	88.9 3 1/2	48.4 1 29/32	42.1 1 21/32	20 3/4	GN207KRRB	SN207K	Z955342 (T18808)	9.761 21.50
RAO	2 11/16	96.84 3 13/16	192.1 7 9/16	88.9 3 1/2	188.9 7 7/16	285.8 11 1/4	360.4 14 3/16	96.0 3 13/16	44.4 1 3/4	25.4 1	33.3 1 5/16	101.6 4	54.8 2 5/32	48.4 1 29/32	22 7/8	GN211KRRB	SO211K	Z955343 (T18810)	15.322 33.75
RAO	2 15/16	104.78 4 1/8	204.8 8 1/16	100.0 3 15/16	201.6 7 15/16	304.8 12	384.2 15 1/8	103.2 4 1/16	47.6 1 7/8	25.4 1	33.3 1 5/16	112.7 4 7/16	62.7 2 15/32	51.6 2 1/32	22 7/8	GN215KRRB	SN215K	Z956395 (T18601)	18.205 40.10

⁽¹⁾LAO assembled with GN-KLLB bearing.

RSA, LSA INDUSTRIAL SERIES

- RSA series is equipped with G-KRRB wide inner ring ball bearings.
- LSA series is equipped with G-KLLB wide inner ring bearings.
- Pillow blocks are prelubricated and ready for immediate use.
- A grease fitting is provided for relubrication if required.
- All units are supplied with a self-locking collar.

Suggested shaft tolerances:

- 1/2 in. – 1 15/16 in.,
nominal to -0.013 mm, -0.0005 in.;
- 2 in. – 3 15/16 in.,
nominal to -0.025 mm, -0.0010 in.

To order, specify UNIT and SHAFT DIAMETER.

Example: RSA 1 7/16 in.

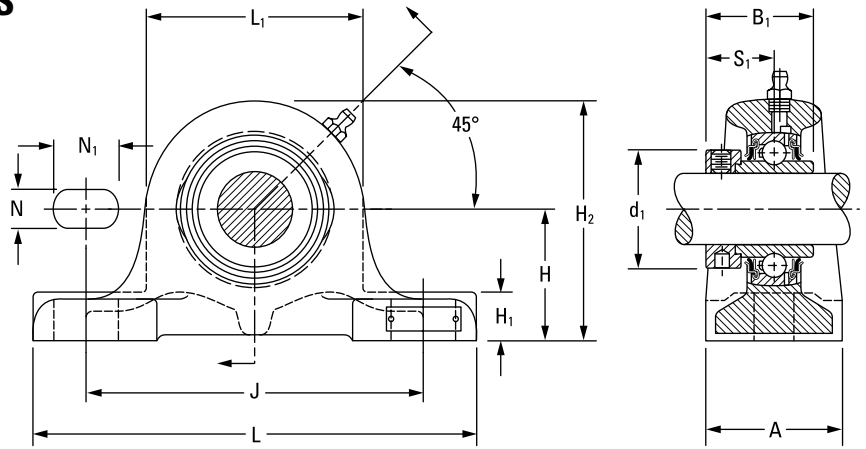

BEARING DATA

Unit	Bearing No.	Dimensions and Load Ratings
RSA	G-KRRB	Page 36
LSA	G-KLLB	Page 39

Unit	Shaft Dia.	Dimensions												Bolt Size	Bearing No.	Collar No.	Housing No. New (Old)	Unit Wt.	
		H	H ₂	B ₁	L ₁	J	L	A	H ₁	N	N ₁	d ₁	S ₁						
	in. mm	mm in.	mm in.	mm in.	mm in.	mm in.	mm in.	mm in.	mm in.	mm in.	mm in.	mm in.	mm in.	mm in.				kg lbs.	
RSA	1/2															G1008KRRB	S1008K		
RSA	5/8	31.75	58.7	37.3	54.0	96.8	122.2	31.8	12.7	11.1	14.3	30.2	23.4	10		G1010KRRB	S1010K	T22784	0.681
RSA	1 1/16	1 1/4	2 5/16	1 15/32	2 1/8	3 13/16	4 13/16	1 1/4	1/2	7/16	9/16	1 3/16	59/64	3/8		G1011KRRB	S1011K		1.50
RSA	17															GE17KRRB	SE17K		
RSA	3/4	44.45	76.2	43.7	63.5	127.0	165.1	50.8	14.3	14.3	19.0	33.3	26.6	12		G1012KRRB	S1012K	Z956559	1.226
RSA	20	1 3/4	3	1 23/32	2 1/2	5	6 1/2	2	9/16	9/16	3/4	1 5/16	1 3/4	1/2		GE20KRRB	SE20K	(T22741)	2.70
RSA	7/8															G1014KRRB	S1014K		
RSA	1 5/16	50.80	85.7	44.4	69.8	139.7	177.8	54.0	15.9	14.3	19.0	38.1	27.0	12		G1015KRRB	S1015K	Z956565	1.521
RSA	1	2	3 3/8	1 3/4	2 3/4	5 1/2	7	2 1/8	5/8	9/16	3/4	1 1/2	1 1/16	1/2		G1100KRRB	S1100K	(T22716)	3.35
RSA	25															GE25KRRB	SE25K		
RSA	1 1/16															G1101KRRB	S1101K		
RSA	1 1/8	50.80	91.3	48.4	81.0	139.7	177.8	54.0	17.5	15.9	20.6	44.1	30.2	12		G1102KRRB	S1102K	Z956538	1.789
RSA, LSA	1 3/16	2	3 19/32	1 29/32	3 3/16	5 1/2	7	2 1/8	1 1/16	5/8	1 3/16	1 47/64	1 3/16	1/2		G1103KRRB	S1103K	(T22725)	3.94
RSA	30															GE30KRRB	SE30K		
RSA, LSA	1 1/4															G1104KRRB	S1104K		
RSA	1 5/16	60.33	111.1	51.2	101.6	158.8	209.6	66.7	22.2	19.0	31.8	54.0	32.5	16		G1105KRRB	S1105K	Z956424	3.260
RSA	1 3/8	2 3/8	4 3/8	2 1/64	4	6 1/4	8 1/4	2 5/8	7/8	3/4	1 1/4	2 1/8	1 9/32	5/8		G1106KRRB	S1106K	(T22382)	7.18
RSA, LSA	1 7/16															G1107KRRB	S1107K		
RSA	35															GE35KRRB	SE35K		
RSA	1 1/2	60.33	111.1	56.4	101.6	168.3	209.6	60.3	19.0	19.0	22.2	60.3	34.9	16		G1108KRRB	S1108KT	Z956558	2.928
RSA	1 9/16	2 3/8	4 3/8	2 7/32	4	6 5/8	8 1/4	2 3/8	3/4	3/4	7/8	2 3/8	1 3/8	5/8		G1109KRRB	S1109KT	(T22752)	6.45
RSA	40															GE40KRRB	SE40K		

Continued on next page.

MOUNTED BALL BEARINGS

CAST-IRON MOUNTED BEARINGS • RSA, LSA

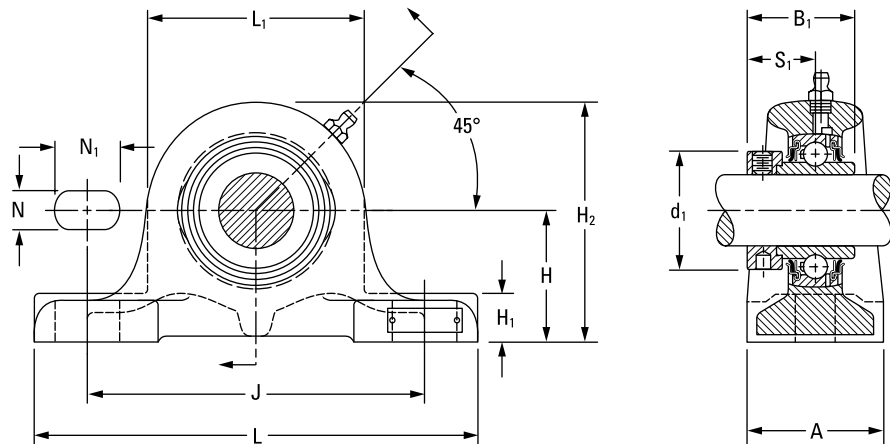

Continued from previous page.

Unit	Shaft Dia.	H	H ₂	B ₁	L ₁	J	L	A	H ₁	N	N ₁	d ₁	S ₁	Bolt Size	Bearing No.	Collar No.	Housing No. New (Old)	Unit Wt.
		mm in.	mm in.	mm in.	mm in.	mm in.	mm in.	mm in.	mm in.	mm in.	mm in.	mm in.	mm in.					
RSA	1 5/8																	
RSA, LSA	1 11/16	60.33	114.3	56.4	108.0	168.3	209.6	60.3	20.6	19.0	23.8	63.5	34.9	16	G1110KRRB	S1110K		
RSA	1 3/4	2 3/8	4 1/2	2 7/32	4 1/4	6 5/8	8 1/4	2 3/8	1 3/16	3/4	1 5/16	2 1/2	1 3/8	5/8	G1111KRRB	S1111K	Z956425	3.064
RSA	45														G1112KRRB	S1112K	(T22701)	6.75
RSA															GE45KRRB	SE45K		
RSA	1 7/8														G1114KRRB	S1114K		
RSA, LSA	1 15/16	69.85	130.2	62.7	120.6	209.6	269.9	69.8	26.2	19.0	34.9	69.8	38.1	16	G1115KRRB	S1115K	Z956478	4.885
RSA	50	2 3/4	5 1/8	2 15/32	4 3/4	8 1/4	10 5/8	2 3/4	1 1/32	3/4	1 3/8	2 3/4	1 1/2	5/8	GE50KRRB	SE50K	(T22384)	10.76
RSA	2														G1200KRRB	S1200K		
RSA	2 1/8	79.38	142.1	71.4	125.4	228.6	288.9	79.4	25.4	19.0	33.3	76.2	43.7	16	G1202KRRB	S1202K	Z956495	6.022
RSA, LSA	2 3/16	3 1/8	5 19/32	2 13/16	4 15/16	9	11 3/8	3 1/8	1	3/4	1 5/16	3	1 23/32	5/8	G1203KRRB	S1203K	(T22696)	13.22
RSA	55														GE55KRRB	SE55K		
RSA	2 1/4														G1204KRRB	S1204K		
RSA	2 3/8	79.38	149.2	77.8	139.7	228.6	288.9	79.4	28.6	22.2	28.6	84.1	46.8	20	G1206KRRB	S1206K	Z956493	6.901
RSA, LSA	2 7/16	3 1/8	5 7/8	3 1/16	5 1/2	9	11 3/8	3 1/8	1 1/8	7/8	1 1/8	3 5/16	1 27/32	3/4	G1207KRRB	S1207K	(T22743)	15.20
RSA	60														GE60KRRB	SE60K		
RSA	2 11/16														G1211KRRB	S1211KT		
RSA	70	95.25	173.0	82.6	155.6	260.4	320.7	88.9	33.3	22.2	34.9	96.8	45.2	20	GE70KRRB	SE70K	Z956560	9.997
		3 3/4	6 13/16	3 1/4	6 1/8	10 1/4	12 5/8	3 1/2	1 5/16	7/8	1 3/8	3 13/16	1 25/32	3/4			(T22748)	22.02
RSA	2 15/16														G1215KRRB	S1215K	Z956514	10.683
RSA	75	3 3/4	7	3 5/8	7 23/32	10 1/4	12 5/8	3 1/2	1 1/2	7/8	1 1/4	4	2 5/32	3/4	GE75KRRB	SE75K	(T22386)	23.53

RSAO, LSAO HEAVY SERIES

- RSAO pillow blocks are equipped with GN-KRRB wide-inner-ring ball bearings.
- LSAO pillow blocks are equipped with GN-KLLB wide-inner-ring ball bearings.
- All units are suited for installations where the load is heavy in proportion to the shaft diameter or where considerable shock loads exist.
- All units are for use in wet or extremely dirty conditions.
- These units are prelubricated and ready for immediate use. A grease fitting is also provided for relubrication if required.
- All units are supplied with a self-locking collar.

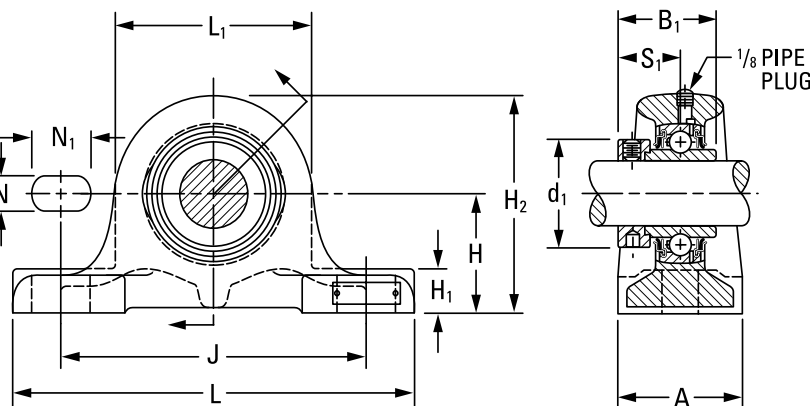

Suggested shaft tolerances:

1 1/16 in., nominal to -0.013 mm, -0.0005 in.;
 2 in. – 3 15/16 in., nominal to -0.025 mm, -0.0010 in.

To order, specify UNIT and SHAFT DIAMETER.

Example: RSAO 1 7/16 in.

BEARING DATA

Unit	Bearing No.	Dimensions and Load Ratings
RSAO	GN-KRRB	Page 59
LSAO	GN-KLLB	Page 61

Unit	Shaft Dia.	Dimensions													Bolt Size	Bearing No.		Collar No.	Housing No. New (Old)	Unit Wt.
		H	H ₂	B ₁	L ₁	J	L	A	H ₁	N	N ₁	d ₁	S ₁	RSAO		LSAO	kg lbs.			
	in.	mm in.	mm in.	mm in.	mm in.	mm in.	mm in.	mm in.	mm in.	mm in.	mm in.	mm in.	mm in.	mm in.						
RSAO, LSAO	1 3/16	60.33 2 3/8	108.0 4 1/4	50.0 1 31/32	95.2 3 3/4	168.3 6 5/8	209.6 8 1/4	60.3 2 3/8	22.2 7/8	15.9 5/8	25.4 1	48.7 1.918	32.5 1.280	12 1/2	GN103KRRB (KLLB)	SN103K	Z956481 (T22678)			
RSAO	1 1/4														GN104KRRB	SN104K		2.937 6.47		
RSAO	1 3/8	69.85 2 3/4	122.2 4 13/16	51.6 2 1/32	104.8 4 1/8	209.6 8 1/4	269.9 10 5/8	69.8 2 3/4	23.8 1 5/16	19.0 3/4	28.6 1 1/8	55.1 2.168	33.3 1 5/16	16 5/8	GN106KRRB	SN106K	Z955362 (T22496)			
RSAO, LSAO	1 7/16														GN107KRRB (KLLB)	SN107K		4.154 9.15		
RSAO, LSAO	1 1/2	79.38 3 1/8	136.6 5 3/8	57.2 2 1/4	114.3 4 1/2	228.6 9	288.9 11 3/8	79.4 3 1/8	27.0 1 1/16	19.0 3/4	28.6 1 1/8	63.0 2.480	37.3 1 5/32	16 5/8	GN108KRRB (KLLB)	SN108K	Z956523 (T22672)	5.857 12.90		
RSAO	1 5/8														GN110KRRB	SN100K				
RSAO, LSAO	1 11/16	79.38 3 1/8	142.9 5 5/8	58.7 2 5/16	127.0 5	228.6 9	288.9 11 3/8	79.4 3 1/8	30.2 1 3/16	19.0 3/4	28.6 1 1/8	69.3 2.730	38.9 1 17/32	16 5/8	GN111KRRB (KLLB)	SN111K	Z955355 (T22498)	6.560 14.45		
RSAO	1 3/4														GN112KRRB	-	SN112K			
RSAO, LSAO	1 15/16	79.38 3 1/8	148.4 5 27/32	66.7 2 5/8	138.1 5 7/16	228.6 9	288.9 11 3/8	79.4 3 1/8	33.3 1 5/16	19.0 3/4	28.6 1 1/8	75.7 2.980	42.1 1 21/32	16 5/8	GN115KRRB (KLLB)	SN115K	Z955352 (T22502)	7.246 15.96		
RSAO	2														GN200KRRB	-	SN200K	Z955345 (T22500)	10.192 22.45	
RSAO, LSAO	2 3/16	95.25 3 3/4	170.7 6 23/32	73.0 2 7/8	150.8 5 15/16	260.4 10 1/4	320.7 12 5/8	88.9 3 1/2	36.5 1 7/16	22.2 7/8	34.9 1 3/8	82.0 3.230	45.2 1 25/32	20 3/4	GN203KRRB (KLLB)	SN203K				
RSAO, LSAO	2 7/16	104.78 4 1/8	186.5 7 11/32	79.4 3 1/8	163.5 6 7/16	285.8 11 1/4	349.2 13 3/4	101.6 4	38.1 1 1/2	22.2 7/8	34.9 1 3/8	88.4 3.480	48.4 1 29/32	20 3/4	GN207KRRB (KLLB)	SN207K	Z955309 (T22494)	16.144 35.56		
RSAO, LSAO	2 11/16	115.89 4 9/16	210.3 8 9/32	88.9 3 1/2	188.9 7 7/16	304.8 12	390.5 15 3/8	111.1 4 3/8	44.4 1 3/4	25.4 1	34.9 1 3/8	101.1 3.980	54.8 2 5/32	22 7/8	GN211KRRB (KLLB)	SO211K	Z956483 (T22492)	19.295 42.50		
RSAO, LSAO	2 15/16	115.89 4 9/16	217.5 8 9/16	100.0 3 15/16	203.2 8	314.3 12 3/8	390.5 15 3/8	111.1 4 3/8	47.6 1 7/8	25.4 1	34.9 1 3/8	112.2 4.418	62.7 2 15/32	22 7/8	GN215KRRB (KLLB)	SN215K	Z956477 (T22490)	20.090 44.25		
RSAO	3 3/16	115.89 4 9/16	223.0 8 25/32	106.4 4 3/16	214.3 8 7/16	314.3 12 3/8	390.5 15 3/8	111.1 4 3/8	49.2 1 15/16	25.4 1	44.4 1 3/4	119.1 4.688	65.9 2 19/32	22 7/8	GN303KRRB	-	SN303K	Z956549 (T22444)	22.814 50.25	
RSAO	3 7/16	130.18 5 1/8	250.8 9 7/8	115.9 4 9/16	241.3 9 1/2	339.7 13 3/8	409.6 16 1/8	120.6 4 3/4	57.2 2 1/4	28.6 1 1/8	54.0 2 1/8	133.4 5.250	73.8 2 29/32	24 1	GN307KRRB	-	SN307K	Z956517 (T22446)	30.986 68.25	
RSAO	3 15/16	144.46 5 11/16	281.0 11 1/16	128.6 5 1/16	273.0 10 3/4	374.6 14 3/4	439.7 17 5/16	130.2 5 1/8	65.1 2 9/16	28.6 1 1/8	44.4 1 3/4	146.0 5.750	78.6 3 3/32	24 1	GN315KRRB	-	SN315K	Z956570 (T22448)	40.633 89.50	

SAL INDUSTRIAL SERIES, FIXED AND FLOATING TYPES

- These types are designed for applications where normal to high temperatures are encountered and applications where one or more floating bearing units are required.
- The floating unit allows the bearing to move axially as the shaft expands from rising temperatures. The fixed unit maintains shaft location.
- The bearings have a loose internal fit.
- The SAL unit is equipped with a self-aligning SM wide-inner-ring bearing and a self-locking collar.
- The external aligning ring is fitted to the spherical surface of the outer ring.
- These types are equipped with oil-tight seals. They're normally fitted for oil lubrication, but they can be equipped for grease lubrication when specified.
- Before installation, lubricate with high-grade automotive oil, turbine oil or ball-bearing grease.
- The units are assembled with a spacer ring (fixed type). By removing the spacer ring, the assembly becomes a floating unit.

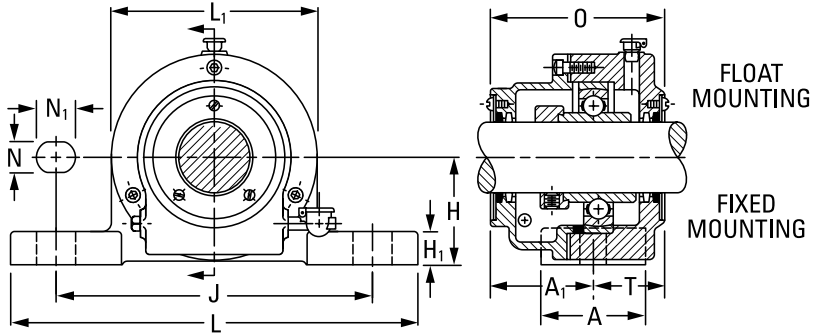

Suggested shaft tolerances:

- 1 3/16 in. – 1 15/16 in., nominal to -0.013 mm, -0.0005 in.;
- 2 in. – 3 7/16 in., nominal to -0.025 mm, -0.0010 in.

To order, specify UNIT and SHAFT DIAMETER and whether fixed or floating.

Example: SAL 1 7/16 in. (one fixed, one floating).

BEARING DATA

Unit	Bearing No.	Dimensions and Load Ratings
SAL	SM-KS	Page 45

Unit	Shaft Dia.	Total Float	Dimensions											Bolt Size	Bearing No.	Collar No.	Housing No.	Unit Wt.		
			H	O	L ₁	A	J	L	N	N ₁	H ₁	A ₁	T							
	in.	mm in.	mm in.	mm in.	mm in.	mm in.	mm in.	mm in.	mm in.	mm in.	mm in.	mm in.	mm in.	mm in.	mm in.	mm in.	mm in.	mm in.	mm in.	kg lbs.
SAL	1 3/16	6.4 1/4	50.80 2	97.6 3 7/32	96.8 3 13/16	54.0 2 1/8	139.7 5 1/2	177.8 7	15.9 5/8	19.0 3/4	17.5 1 1/16	56.4 2 1/32	41.3 1 5/8	12 1/2	SM1103KS	S1103K	T12127		3.768 8.30	
SAL	1 1/4	6.4 1/4	60.33 2 3/8	104.8 4 1/8	108.0 4 1/4	60.3 2 3/8	158.8 6 1/4	210.0 8 1/4	19.0 3/4	25.4 1	19.0 3/4	62.7 2 15/32	42.1 1 21/32	16 5/8	SM1104KS	S1104K	Z956651 (T13108)		5.239 11.54	
SAL	1 7/16	6.4 1/4	60.33 2 3/8	104.8 4 1/8	108.0 4 1/4	60.3 2 3/8	158.8 6 1/4	210.0 8 1/4	19.0 3/4	25.4 1	19.0 3/4	62.7 2 15/32	42.1 1 21/32	16 5/8	SM1107KS	S1107K	Z956651 (T13108)		5.239 11.54	
SAL	1 1/2	7.9 5/16	60.33 2 3/8	108.0 4 1/4	120.6 4 3/4	60.3 2 3/8	168.3 6 5/8	210.0 8 1/4	19.0 3/4	25.4 1	19.0 3/4	63.5 2 1/2	44.4 1 3/4	16 5/8	SM1108KTS	S1108KT	T12121		6.143 13.53	
SAL	1 11/16	7.9 5/16	60.33 2 3/8	110.3 4 11/32	120.6 4 3/4	60.3 2 3/8	168.3 6 5/8	210.0 8 1/4	19.0 3/4	25.4 1	19.0 3/4	65.9 2 19/32	44.4 1 3/4	16 5/8	SM1111KS	S1111K	T12121		5.866 12.92	
SAL	1 15/16	7.9 5/16	69.85 2 3/4	116.7 4 19/32	133.4 5 1/4	69.8 2 3/4	210.0 8 1/4	269.9 10 5/8	19.0 3/4	25.4 1	22.2 7/8	69.1 2 23/32	47.6 1 7/8	16 5/8	SM1115KS	S1115K	Z956561 (T12313)		8.113 17.87	
SAL	2 3/16	7.9 5/16	79.38 3 1/8	137.3 5 13/32	146.0 5 3/4	79.4 3 1/8	228.6 9	288.9 11 3/8	19.0 3/4	25.4 1	22.2 7/8	79.4 3 1/8	57.9 2 9/32	16 5/8	SM1203KS	S1203K	Z956557 (A5845)		10.978 24.18	
SAL	2 7/16	9.5 3/8	79.38 3 1/8	150.0 5 29/32	158.8 6 1/4	79.4 3 1/8	228.6 9	288.9 11 3/8	19.0 3/4	25.4 1	22.2 7/8	88.9 3 1/2	61.1 2 13/32	16 5/8	SM1207KS	S1207K	Z956564 (A5083)		12.894 28.40	
SAL	2 11/16	7.1 9/32	95.25 3 3/4	156.4 6 5/32	171.4 6 3/4	88.9 3 1/2	259.7 10 1/4	320.7 12 5/8	22.2 7/8	28.6 1 1/8	27.0 1 1/16	92.1 3 5/8	64.3 2 17/32	20 3/4	SM1211KTS	S1211K	Z956562 (T18940)		15.889 35.02	
SAL	2 15/16	9.9 25/64	95.25 3 3/4	173.8 6 27/32	190.5 7 1/2	88.9 3 1/2	259.7 10 1/4	320.7 12 5/8	22.2 7/8	28.6 1 1/8	27.0 1 1/16	100.8 3 31/32	73.0 2 7/8	20 3/4	SM1215KS	S1215K	A5088		20.203 44.50	
SAL	3 7/16	9.5 3/8	115.89 4 9/16	186.5 7 11/32	212.7 8 3/8	111.1 4 3/8	314.3 12 3/8	390.6 15 3/8	25.4 1	31.8 1 1/4	31.8 1 1/4	107.2 4 7/32	79.4 3 1/8	22 7/8	SM1307KS	S1307K	A5206		33.482 73.75	

SAOL HEAVY SERIES, FIXED AND FLOATING TYPES

- These types are designed for applications with higher- than-usual temperatures or where one or more floating bearing units are required.
- The floating unit allows the bearing to move axially as the shaft expands from rising temperatures. The fixed unit maintains shaft location.
- The bearings have a loose internal fit.
- The SAOL unit is equipped with a self-aligning SMN wide-inner-ring ball bearing and a self-locking collar.
- The external aligning ring is fitted to the spherical surface of the outer ring.
- These types are equipped with oil-type seals. They're normally fitted for oil lubrication, but they can be equipped for grease lubrication when specified.
- Before installation, lubricate with high-grade automotive oil, turbine oil or ball-bearing grease.
- The units are assembled with a spacer ring (fixed type). By removing the spacer ring, the assembly becomes a floating unit.

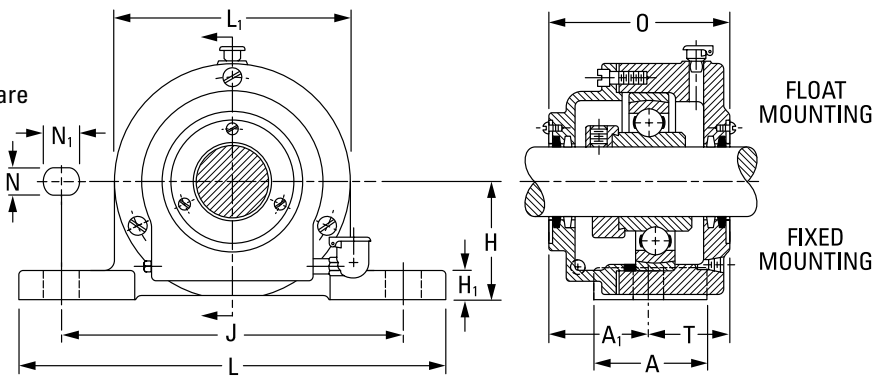

1 3/16 in. – 1 15/16 in., nominal to -0.013 mm, -0.0005 in.;
 2 in. – 3 15/16 in., nominal to -0.025 mm, -0.0010 in.
 Larger sizes, consult your Timken engineer.

To order, specify UNIT and SHAFT DIAMETER and whether fixed or floating.

Example: SAOL 1 7/16 in. (one fixed, one floating).

Suggested shaft tolerances:

BEARING DATA

Unit	Bearing No.	Dimensions and Load Ratings
SAOL	SMN-KS	Page 64

Unit	Shaft Dia.	Total Float	Dimensions													Bolt		Bearing No.	Collar No.	Housing No. New (Old)	Unit Wt.		
			H	O	L ₁	A	J	L	N	N ₁	H ₁	A ₁	T	J ₁ ⁽¹⁾	No.	Size	kg				lbs.		
	in.	mm in.	mm in.	mm in.	mm in.	mm in.	mm in.	mm in.	mm in.	mm in.	mm in.	mm in.	mm in.	mm in.	mm in.	mm in.	mm in.						
SAOL	1 3/16	7.9 5/16	60.33 2 3/8	103.2 4 1/16	111.1 4 3/8	60.3 2 3/8	168.3 6 5/8	210.0 8 1/4	15.9 5/8	22.2 7/8	17.5 11/16	60.3 2 3/8	42.9 1 11/16	-	2	12 1/2	SMN103KS	SN103K	Z956594 (T12389)	5.521 12.16			
SAOL	1 1/4	9.1 23/64	69.80 2 3/4	111.1 4 3/8	120.6 4 3/4	69.8 2 3/4	209.6 8 1/4	269.9 10 5/8	19.0 3/4	25.4 1	20.6 13/16	69.1 2 29/32	42.1 1 21/32	-	2	16 5/8	SMN104KS SMN107KS	SN104K SN107K	Z956598 (A4779)	7.037 15.50			
SAOL	1 1/2	9.5 3/8	79.40 3 1/8	123.8 4 7/8	146.0 5 3/4	79.4 3 1/8	228.6 9	288.9 11 3/8	19.0 3/4	25.4 1	20.6 13/16	74.6 2 15/16	49.2 1 15/16	-	2	16 5/8	SMN108KS	SN108K	Z956591 (T24004)	11.350 25.00			
SAOL	1 11/16	9.5 3/8	79.40 3 1/8	123.8 4 7/8	146.0 5 3/4	79.4 3 1/8	228.6 9	288.9 11 3/8	19.0 3/4	25.4 1	20.6 13/16	74.6 2 15/16	49.2 1 15/16	-	2	16 5/8	SMN111KS	SN111K	Z956577 (A4778)	11.150 24.56			
SAOL	1 15/16	9.5 3/8	79.40 3 1/8	122.2 4 13/16	158.8 6 1/4	79.4 3 1/8	228.6 9	288.9 11 3/8	19.0 3/4	25.4 1	20.6 13/16	73.8 2 29/32	48.4 1 29/32	-	2	16 5/8	SMN115KS	SN115K	Z956524 (A3818)	12.462 27.45			
SAOL	2 3/16	9.1 23/64	95.25 3 3/4	139.7 5 1/2	171.4 6 3/4	88.9 3 1/2	259.7 10 1/4	320.7 12 5/8	22.2 7/8	31.8 1 1/4	27.0 1 1/16	82.6 3 1/4	57.2 2 1/4	-	2	20 3/4	SMN203KS	SN203K	Z956539 (A4755)	15.409 33.94			
SAOL	2 7/16	8.7 11/32	104.80 4 1/8	150.0 5 29/32	190.5 7 1/2	101.6 4	285.8 11 1/4	349.2 13 3/4	22.2 7/8	31.8 1 1/4	27.0 1 1/16	91.3 3 19/32	58.7 2 5/16	-	2	20 3/4	SMN207KS	SN207K	Z956505 (A3819)	18.841 41.50			
SAOL	2 11/16	9.5 3/8	115.89 4 9/16	174.6 6 7/8	215.9 8 1/2	111.1 4 3/8	304.8 12	390.6 15 3/8	25.4 1	31.8 1 1/4	31.8 1 1/4	109.5 4 5/16	65.1 2 9/16	-	2	22 7/8	SMN211KS	SO211K	Z956520 (A4709)	26.332 58.00			

⁽¹⁾When four bolts are used, dimension J₁ is the distance between centers, and A₁ and T are measured from the center of the base.

Continued on next page.

MOUNTED BALL BEARINGS

CAST-IRON MOUNTED BEARINGS • SAOL

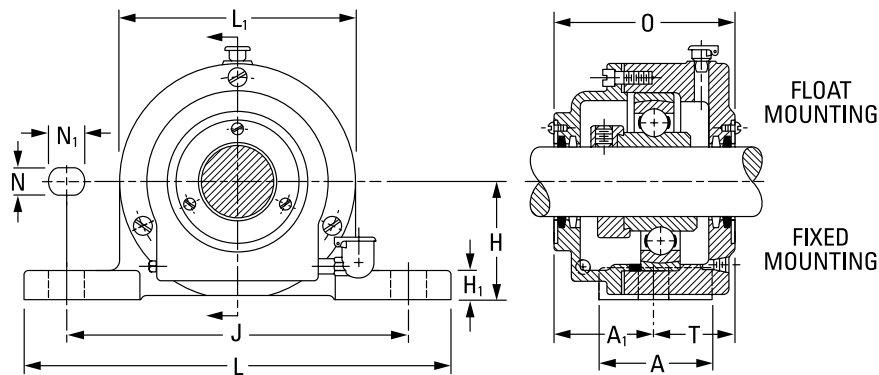

Continued from previous page.

Unit	Shaft Dia.	Total Float														Bolt		Bearing No.	Collar No.	Housing No. New (Old)	Unit Wt.
			H	O	L ₁	A	J	L	N	N ₁	H ₁	A ₁	T	J ₁ ⁽¹⁾	No.	Size	kg lbs.				
	in.	mm in.	mm in.	mm in.	mm in.	mm in.	mm in.	mm in.	mm in.	mm in.	mm in.	mm in.	mm in.	mm in.	mm in.	mm in.	mm in.				
SAOL	2 ¹⁵ / ₁₆	12.7 1/2	115.89 4 ⁹ / ₁₆	177.8 7	225.4 8 ⁷ / ₈	111.1 4 ³ / ₈	314.3 12 ³ / ₈	390.6 15 ³ / ₈	25.4 1	31.8 1 ¹ / ₄	31.8 1 ¹ / ₄	104.8 4 ¹ / ₈	73.0 2 ⁷ / ₈	—	2	22 7/8	SMN215KS	SN215K	Z956484 (T90046)	33.823 74.50	
SAOL	3 ³ / ₁₆	13.1 3 ³ / ₆₄	115.89 4 ⁹ / ₁₆	184.2 7 ¹ / ₄	241.3 9 ¹ / ₂	111.1 4 ³ / ₈	314.3 12 ³ / ₈	390.6 15 ³ / ₈	25.4 1	31.8 1 ¹ / ₄	31.8 1 ¹ / ₄	108.0 4 ¹ / ₄	76.2 3	57.2 2 ¹ / ₄	4	22 7/8	SMN303KS	SN303K	Z956552 (A4780)	35.298 77.75	
SAOL	3 ⁷ / ₁₆	13.5 17/32	130.2 5 ¹ / ₈	190.5 7 ¹ / ₂	260.4 10 ¹ / ₄	120.6 4 ³ / ₄	339.7 13 ³ / ₈	409.6 16 ¹ / ₈	25.4 1	31.8 1 ¹ / ₄	31.8 1 ¹ / ₄	111.1 4 ³ / ₈	79.4 3 ¹ / ₈	76.2 3	4	22 7/8	SMN307KS	SN307K	Z956515 (A4155)	48.805 107.5	
SAOL	3 ¹¹ / ₁₆	12.7 1/2	144.5 5 ¹¹ / ₁₆	213.5 8 ¹³ / ₃₂	279.4 11	125.4 4 ¹⁵ / ₁₆	374.6 14 ³ / ₄	439.7 17 ⁵ / ₁₆	28.6 1 ¹ / ₈	38.1 1 ¹ / ₂	31.8 1 ¹ / ₄	133.4 5 ¹ / ₄	80.2 3 ⁵ / ₃₂	—	2	24 1	SMO311WS	SO311K	Z956610 (A4156)	54.48 120.0	
SAOL	3 ¹⁵ / ₁₆	17.5 1 ¹ / ₁₆	152.4 6	219.9 8 ²¹ / ₃₂	298.4 11 ³ / ₄	133.4 5 ¹ / ₄	393.1 15 ¹ / ₂	469.9 18 ¹ / ₂	28.6 1 ¹ / ₈	38.1 1 ¹ / ₂	34.9 1 ³ / ₈	127.0 5	92.9 3 ²¹ / ₃₂	82.6 3 ¹ / ₄	4	24 1	SMN315KS	SN315K	Z956550 (A4795)	70.824 156.0	
SAOL	4 ³ / ₁₆	15.9 5/8	165.1 6 ¹ / ₂	225.4 8 ⁷ / ₈	317.5 12 ¹ / ₂	158.8 6 ¹ / ₄	449.3 17 ¹¹ / ₁₆	539.8 21 ¹ / ₄	28.6 1 ¹ / ₈	38.1 1 ¹ / ₂	38.1 1 ¹ / ₂	134.1 5 ⁹ / ₃₂	91.3 3 ¹⁹ / ₃₂	101.6 4	4	24 1	SMN403WS	SN403K	Z956602 (T14342)	88.076 194.0	
SAOL	4 ⁷ / ₁₆	14.3 9/16	177.8 7	228.6 9	327.0 12 ¹ / ₈	171.4 6 ³ / ₄	449.3 17 ¹¹ / ₁₆	539.8 21 ¹ / ₄	31.8 1 ¹ / ₄	44.4 1 ³ / ₄	44.4 1 ³ / ₄	134.9 5 ⁵ / ₁₆	93.6 3 ¹¹ / ₁₆	108.0 4 ¹ / ₄	4	27 1 ¹ / ₈	SMN407WS	SN407K	Z956578 (T11469)	95.34 210.0	
SAOL	4 ¹⁵ / ₁₆	31.4 1 ¹⁵ / ₆₄	209.6 8 ¹ / ₄	261.9 10 ⁵ / ₁₆	381.0 15	184.2 7 ¹ / ₄	514.4 20 ¹ / ₄	630.2 24 ¹³ / ₁₆	31.8 1 ¹ / ₄	44.4 1 ³ / ₄	50.8 2	152.4 6	109.5 4 ⁵ / ₁₆	120.6 4 ³ / ₄	4	27 1 ¹ / ₈	SMN415WS	SN415K	Z956576 (T11783)	160.262 353.0	

⁽¹⁾When four bolts are used, dimension J₁ is the distance between centers, and A₁ and T are measured from the center of the base.

DRNR INDUSTRIAL SERIES

- This rigid double pillow block is designed to provide a sturdy two-bearing mounting for fans and blowers, bench grinders, buffers, vertical shafts and similar heavy-duty applications.
- The compact, one-piece housing is equipped with two wide-inner-ring ball bearings with integral R-seals and a self-locking collar.
- Individual grease chambers are provided for both bearings.
- The close clearance baffles allow excess grease to work into the center chamber of the housing.
- The grease fittings that take the place of standard pipe plugs provide the means of relubrication.
- This pillow block can be mounted in any position, with ample radial and thrust capacity.

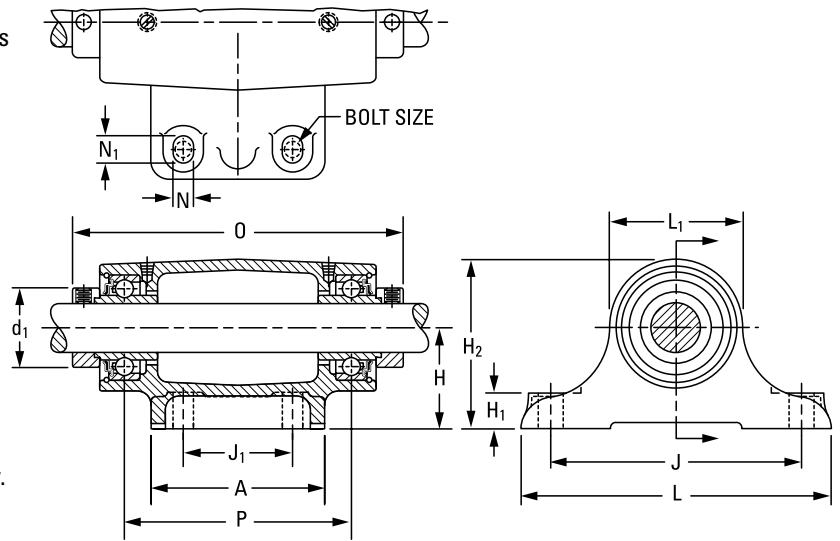

Suggested shaft tolerances:

1⁵/₁₆ in. – 1¹⁵/₁₆ in., nominal to -0.013 mm, -0.0005 in.;
 2 in. – 2³/₁₆ in., nominal to -0.025 mm, -0.0010 in.

To order, specify UNIT and SHAFT DIAMETER.

Example: DRNR 1⁷/₁₆ in.

BEARING DATA

Unit	Bearing No.	Dimensions and Load Ratings
DRNR	KR	Page 34

Unit	Shaft Dia.	H	H ₂	O	L ₁	J	L	A	H ₁	N	N ₁	J ₁	d ₁	P	Bolt (4 req'd)	Bearing No. (2 req'd)	Collar No.	Housing No. New (Old)	Unit Wt.
		in.	mm in.	mm in.	mm in.	mm in.	mm in.	mm in.	mm in.	mm in.	mm in.	mm in.	mm in.	mm in.					
DRNR	1 ⁵ / ₁₆	63.5	99.2	200.0	71.4	158.8	196.8	108.0	19.0	12.7	15.9	69.8	38.1	146.0	10	1015KR	S1015K	Z956569 (T19189)	4.812
DRNR	1	2 ¹ / ₂	3 ²⁹ / ₃₂	7 ⁷ / ₈	2 ¹³ / ₁₆	6 ¹ / ₄	7 ³ / ₄	4 ¹ / ₄	3 ⁴ / ₈	1 ² / ₂	5 ⁸ / ₈	2 ³ / ₄	1 ¹ / ₂	5 ³ / ₄	3 ⁸ / ₈	1100KR	S1016K	Z956579 (T19195)	10.60
DRNR	25															E25KR	SE25K		
DRNR	1 ³ / ₁₆	63.5	105.6	203.2	84.1	158.8	196.8	108.0	22.2	12.7	15.9	69.8	44.1	142.9	10	1103KR	S1103K	Z956583 (T19191)	5.167
DRNR	1 ³ / ₁₆	2 ¹ / ₂	4 ⁵ / ₃₂	8	3 ⁵ / ₁₆	6 ¹ / ₄	7 ³ / ₄	4 ¹ / ₄	7 ⁸ / ₈	1 ² / ₂	5 ⁸ / ₈	2 ³ / ₄	1 ⁴⁷ / ₆₄	5 ⁵ / ₈	3 ⁸ / ₈	1103KR	S1103K	Z956583 (T19191)	11.38
DRNR	1 ¹ / ₄	76.2	123.8	276.2	95.2	203.2	254.0	139.7	25.4	15.9	22.2	88.9	54.0	211.5	12	1104KR	S1104K	Z956545 (T19193)	9.625
DRNR	1 ⁷ / ₁₆	3	4 ⁷ / ₈	10 ⁷ / ₈	3 ³ / ₄	8	10	5 ¹ / ₂	1	5 ⁸ / ₈	7 ⁸ / ₈	3 ¹ / ₂	2 ¹ / ₈	8 ²¹ / ₆₄	1 ² / ₂	1107KR	S1107K	Z956545 (T19193)	21.20
DRNR	1 ¹¹ / ₁₆	76.2	133.4	279.4	114.3	203.2	254.0	139.7	25.4	15.9	22.2	88.9	63.5	209.6	12	1111KR	S1111K	Z956556 (T19197)	11.690
DRNR	1 ¹¹ / ₁₆	3	5 ¹ / ₄	11	4 ¹ / ₂	8	10	5 ¹ / ₂	1	5 ⁸ / ₈	7 ⁸ / ₈	3 ¹ / ₂	2 ¹ / ₂	8 ¹ / ₄	1 ² / ₂	1111KR	S1111K	Z956556 (T19197)	25.75
DRNR	1 ¹⁵ / ₁₆	88.9	150.8	352.4	123.8	241.3	304.8	177.8	28.5	17.5	28.5	114.3	69.8	276.2	16	1115KR	S1115K	Z956579 (T19195)	18.841
DRNR	1 ¹⁵ / ₁₆	3 ¹ / ₂	5 ⁵ / ₁₆	13 ⁷ / ₈	4 ⁷ / ₈	9 ¹ / ₂	12	7	1 ¹ / ₈	1 ¹ / ₁₆	1 ¹ / ₈	4 ¹ / ₂	2 ³ / ₄	10 ⁷ / ₈	5 ⁸ / ₈	1115KR	S1115K	Z956579 (T19195)	41.50
DRNR	2 ³ / ₁₆	88.9	158.8	355.6	133.4	241.3	304.8	177.8	31.8	17.5	28.5	114.3	76.2	268.3	16	1203KR	S1203K	Z956553 (A9598)	23.608
DRNR	2 ³ / ₁₆	3 ¹ / ₂	6 ¹ / ₄	14	5 ¹ / ₄	9 ¹ / ₂	12	7	1 ¹ / ₄	1 ¹ / ₁₆	1 ¹ / ₈	4 ¹ / ₂	3	10 ⁹ / ₁₆	5 ⁸ / ₈	1203KR	S1203K	Z956553 (A9598)	52.00

CAST-IRON FLANGED UNITS RCJ, TCJ, LCJ INDUSTRIAL SERIES

- Timken Fafnir cartridges are used in applications where a minimum amount of machining is to be done.
- Each unit comes assembled and ready for mounting, with bolts through the flange.
- These are wide-inner-ring ball bearings, self-aligning B-types, which compensate for shaft misalignment.
- The RCJ flange cartridge is equipped with G-KRRB (R-seal) wide-inner-ring ball bearings. The TCJ is equipped with G-KPPB (tri-ply seal) wide-inner-ring ball bearings. The LCJ is equipped with the G-KLLB (Mechani-seal) wide-inner-ring ball bearings.
- The TCJ flange cartridges are identical to RCJ units, except they use the tri-ply seal bearing. Tri-ply units offer the best protection in dirty environments.
- The units are factory-prelubricated, but a grease fitting is provided for relubrication if required. The units are supplied with self-locking collars.

- Contact a Timken engineer to discuss highly corrosive applications (food processing, chemical exposure) where Timken thin-dense chrome-coated bearings can be used.
- Safety end caps are available for selected sizes.

Suggested shaft tolerances:

1 13/16 in. – 1 15/16 in., nominal to -0.013 mm, -0.0005 in. ;
2 in. – 2 15/16 in., nominal to -0.025 mm, -0.0010 in.

For larger sizes, consult your Timken engineer.

To order, specify UNIT and SHAFT DIAMETER.

Example: RCJ 1 3/16 in.

BEARING DATA

Unit	Bearing No.	Dimensions and Load Ratings
RCJ	G-KRRB	Page 36
TCJ	G-KPPB	Page 41
LCJ	G-KLLB	Page 39

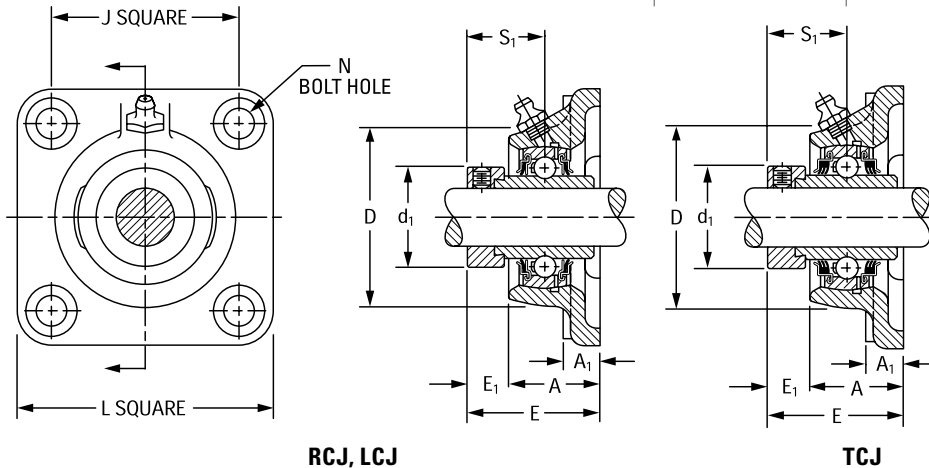

RCJ, LCJ

TCJ

Unit ⁽¹⁾	Shaft Dia.	Dimensions										Bolt Size	Bearing No. ⁽²⁾ RCJ (TCJ)	Collar No.	Housing No. New (Old)	Unit Wt.	
		L	J	A ₁	A	E	N	E ₁	S ₁	D	d ₁						
	in. mm	mm in.	mm in.	mm in.	mm in.	mm in.	mm in.	mm in.	mm in.	mm in.	mm in.	mm in.					kg lbs.
RCJ	1/2												G1008KRRB	S1008K			
RCJ	5/8	76.2	54.0	9.5	23.6	40.6	10.7	13.9	23.4	52.4	28.1	10	G1010KRRB	S1010K	Z955368	(T40278)	0.526
RCJ	11/16	3	2 1/8	13/32	0.929	1.599	27/64	35/64	59/64	2 1/16	1.105	3/8	G1011KRRB	S1011K			1.16
RCJ	17												GE17KRRB	SE17K			
RCJ	3/4	85.7	63.5	11.1	27.8	46.4	10.7	16.3	26.6	60.3	32.8	10	G1012KRRB	S1012K	Z955369	(T40229)	0.726
RCJ	20	3 3/8	2 1/2	7/16	1.094	1.828	27/64	41/64	1 3/64	2 3/8	1.292	3/8	GE20KRRB	SE20K			1.60
RCJ, TCJ	7/8												G1014KRRB (KPPB3)	S1014K			
RCJ, TCJ	15/16	95.2	69.8	12.7	27.9	46.6	11.5	15.9	27.0	65.1	37.6	10	G1015KRRB (KPPB3)	S1015K	Z955370	(T40230)	0.939
RCJ, TCJ	1	3 3/4	2 3/4	1/2	1.100	1.834	29/64	5/8	1 1/16	2 9/16	1.480	3/8	G1100KRRB (KPPB3)	S1100K			2.07
RCJ, TCJ	25												GE25KRRB (KPPB3)	SE25K			
RCJ, TCJ	1 1/16												G1101KRRB (KPPB3)	S1101K			
RCJ, TCJ	1 1/8	107.9	82.6	13.5	29.9	50.5	11.5	17.5	30.2	76.2	43.9	10	G1102KRRB (KPPB3)	S1102K	Z955371	(T40231)	1.302
RCJ, TCJ	1 3/16	4 1/4	3 1/4	17/32	1.178	1.990	29/64	11/16	1 3/16	3	1.730	3/8	G1103KRRB (KPPB3)	S1103K			2.87
RCJ, TCJ	30												GE30KRRB (KPPB3)	SE30K			

⁽¹⁾Type LCJ uses G-KLLB.

⁽²⁾Bearing number for RCJ is G-KRRB. TCJ uses G-KPPB.

Continued on next page.

RCJ, TCJ, LCJ INDUSTRIAL SERIES – continued

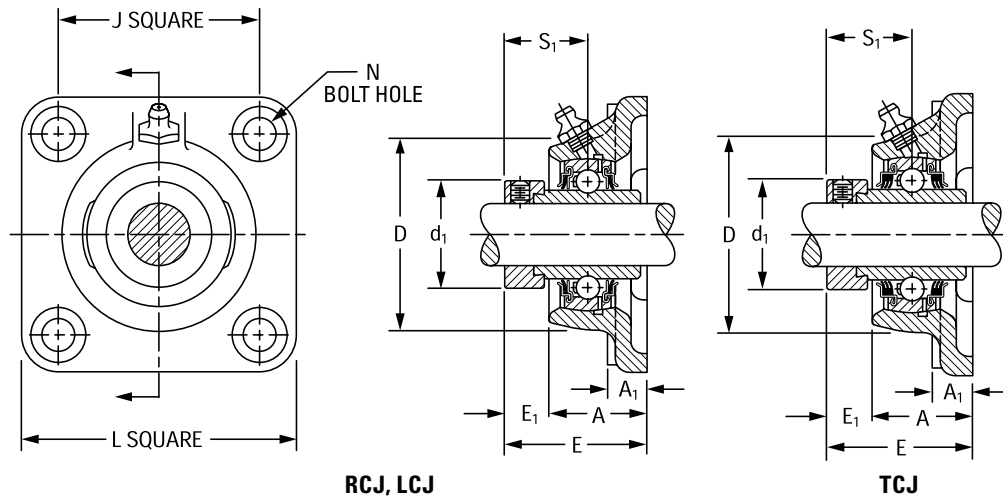

Continued from previous page.

Unit ⁽¹⁾	Shaft Dia.											Bolt Size	Bearing No. ⁽²⁾		Collar No.	Housing No. New (Old)	Unit Wt.	
		L	J	A ₁	A	E	N	E ₁	S ₁	D	d ₁		RCJ	(TCJ)				
	in. mm	mm in.	mm in.	mm in.	mm in.	mm in.	mm in.	mm in.	mm in.	mm in.	mm in.	mm in.	mm in.					kg lbs.
RCJ, TCJ	1 1/4													12	G1104KRRB (KPPB2)	S1104K		
RCJ, TCJ	1 5/16													12	G1105KRRB (KPPB2)	S1105K	Z955372	1.787
RCJ, TCJ	1 3/8	117.5	92.1	13.5	31.8	53.5	13.1	19.0	32.5	88.9	53.6	12	1/2	G1106KRRB (KPPB2)	S1106K	(T40232)	3.94	
RCJ, TCJ	1 7/16	4 5/8	3 5/8	17/32	1.254	2.106	33/64	3/4	1 9/32	3 1/2	2.112			G1107KRRB (KPPB2)	S1107K			
RCJ, TCJ	35														GE35KRRB (KPPB2)	SE35K		
RCJ, TCJ	1 1/2													12	G1108KRRB (KPPB3)	S1108KT		
RCJ, TCJ	1 9/16	130.2	101.6	14.3	38.1	59.3	13.1	20.6	34.9	98.4	58.2	12	1/2	G1109KRRB (KPPB3)	S1109KT	Z955373	2.291	
RCJ, TCJ	40	5 1/8	4	9/16	1.500	2.334	33/64	13/16	1 3/8	3 7/8	2.292			GE40KRRB (KPPB3)	SE40K	(T40233)	5.05	
RCJ, TCJ	1 5/8													12	G1110KRRB (KPPB4)	S1110K		
RCJ, TCJ	1 11/16	136.5	104.8	14.3	38.9	59.3	13.1	19.8	34.9	104.8	63.0	12	1/2	G1111KRRB (KPPB4)	S1111K	Z955374	2.585	
RCJ, TCJ	1 3/4	5 3/8	4 1/8	9/16	1.531	2.334	33/64	25/32	1 3/8	4 1/8	2.480			G1112KRRB (KPPB4)	S1112K	(T40234)	5.70	
RCJ, TCJ	45														GE45KRRB (KPPB4)	SE45K		
RCJ, TCJ	1 7/8													16	G1114KRRB (KPPB3)	S1114K		
RCJ, TCJ	1 15/16	142.9	111.1	14.3	42.9	66.4	17.1	23.0	38.1	112.7	69.3	16	5/8	G1115KRRB (KPPB3)	S1115K	Z955375	3.016	
RCJ, TCJ	50	5 5/8	4 3/8	9/16	1.688	2.615	43/64	29/32	1 1/2	4 7/16	2.730			GE50KRRB (KPPB3)	SE50K	(T40235)	6.65	
RCJ, TCJ	2													16	G1200KRRB (KPPB4)	S1200K		
RCJ, TCJ	2 1/8	161.9	130.2	16.7	46.8	75.1	17.1	27.8	43.7	120.6	75.7	16	5/8	G1202KRRB (KPPB4)	S1202K	Z955376	3.842	
RCJ, TCJ	2 3/16	6 3/8	5 1/8	21/32	1.844	2.958	43/64	1 3/32	1 23/32	4 3/4	2.980			G1203KRRB (KPPB4)	S1203K	(T40236)	8.47	
RCJ, TCJ	55														GE55KRRB (KPPB4)	SE55K		
RCJ	2 1/4													16	G1204KRRB	S1204K		
RCJ	2 3/8	174.6	142.9	17.5	49.2	81.6	17.1	31.8	46.8	136.5	83.6	16	5/8	G1206KRRB	S1206K	Z955316	5.048	
RCJ	2 7/16	6 7/8	5 5/8	11/16	1.937	3.214	43/64	1 1/4	1 27/32	5 3/8	3.292			G1207KRRB	S1207K	(T40237)	11.13	
RCJ	60														GE60KRRB	SE60K		
RCJ	2 11/16	187.3	149.2	19.1	63.5	90.3	16.3	25.4	45.2	152.4	96.3	16	5/8	G1211KRRB	S1211K	Z956389	6.885	
RCJ	70	7 3/8	5 7/8	3/4	2.500	3.557	41/64	1	1 27/32	6	3.792			GE70KRRB	SE70K	(T22530)	15.18	
RCJ	2 15/16	196.8	152.4	22.2	66.7	96.7	19.8	26.2	54.8	161.9	101.1	16	5/8	G1215KRRB	S1215K	Z955323	8.210	
RCJ	75	7 3/4	6	7/8	2.625	3.807	25/32	1 1/32	2 5/32	6 3/8	3.980			GE75KRRB	SE75K	(T21620)	18.100	

⁽¹⁾Type LCJ uses G-KLLB.

⁽²⁾Bearing number for RCJ is G-KRRB. TCJ uses G-KPPB.

**RCJC INDUSTRIAL-SERIES
CONCENTRIC COLLAR**

- These units have the same basic design as the RCJ series, except a concentric collar is used as the shaft-locking device instead of a self-locking cam collar.
- All RCJC units are equipped with GC-KRRB wide inner ring, concentric-collar bearings.
- The spherical outside diameter of the bearings is mounted in corresponding machined housing seats to provide the initial self-alignment.
- The bolt-hole spacing dimensions are interchangeable with the RCJ series and most competitive units.
- The units are factory-prelubricated, but a grease fitting is provided for relubrication if required.
- Concentric collars are supplied with all units.
- Safety end caps are available for selected sizes.

Suggested shaft tolerances:

1/2 in. – 1 15/16 in., nominal to -0.013 mm, -0.0005 in.;
2 in. – 2 15/16 in., nominal to -0.025 mm, -0.0010 in.

To order, specify UNIT and SHAFT DIAMETER.

Example: RCJC 1 3/16 in.

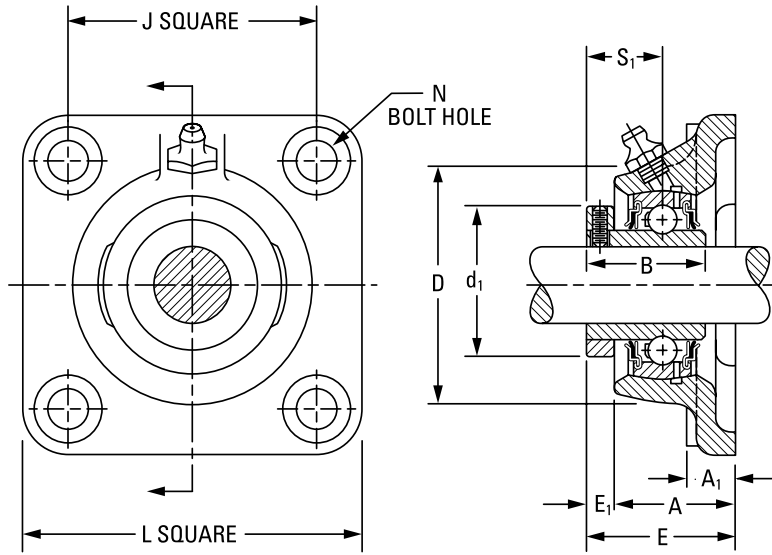

BEARING DATA

Unit	Bearing No.	Dimensions and Load Ratings
RCJC	GC-KRRB	Page 42

Unit	Shaft Dia.	Dimensions											Bolt Size	Bearing No.	Collar No.	Housing No. New (Old)	Unit Wt.
		L	J	A ₁	A	E	N	E ₁	B	D	d ₁	S ₁					
	in.	mm in.	mm in.	mm in.	mm in.	mm in.	mm in.	mm in.	mm in.	mm in.	mm in.	mm in.					kg lbs.
RCJC	1/2												10	GC1008KRRB			
RCJC	5/8	76.2	53.98	11.1	22.2	30.2	9.9	7.9	26.6	52.4	34.1	15.5	10	GC1010KRRB	C203	T27113	0.486
RCJC	11/16	3	2 1/8	7/16	7/8	1 3/16	29/64	5/16	1 3/64	2 1/16	1 11/32	39/64	3/8	GC1011KRRB			1.07
RCJC	3/4	85.7	63.5	11.1	25.8	32.5	9.9	6.7	31.0	60.3	38.1	18.7	10	GC1012KRRB	C204	Z956534 (T26605)	0.645
RCJC	7/8	3 3/8	2 1/2	7/16	1 1/64	1 9/32	25/64	17/64	17/32	2 3/8	1 1/2	47/64	3/8				1.42
RCJC	15/16	95.2	69.85	11.1	28.6	36.1	11.5	7.5	34.1	65.1	44.4	20.2	10	GC1014KRRB			0.781
RCJC	1	3 3/4	2 3/4	7/16	1 1/8	1 27/64	29/64	19/64	1 11/32	2 9/16	1 3/4	51/64	3/8	GC1015KRRB	C205	Z956479 (T26614)	1.72
RCJC	1 1/8												10	GC1100KRRB			
RCJC	1 3/16	107.9	82.55	12.7	30.2	39.3	11.5	9.1	37.3	76.2	52.4	22.6	10	GC1102KRRB			1.135
RCJC	1 1/4	4 1/4	3 1/4	1/2	13/16	1 35/64	29/64	23/64	1 15/32	3	2 1/16	57/64	3/8	GC1103KRRB	C206	Z956551 (T26631)	2.50
RCJC	1 1/4 S													GC1103KRRB3			
RCJC	1 1/4	117.5	92.08	14.3	34.1	44.4	13.1	10.3	41.3	88.9	59.5	25.4	12	GC1104KRRB			1.707
RCJC	1 3/8	4 5/8	3 5/8	9/16	1 11/32	1 3/4	33/64	13/32	1 5/8	3 1/2	2 11/32	1	12	GC1106KRRB	C207	Z956427 (T26665)	3.76
RCJC	1 7/16													GC1107KRRB			
RCJC	1 1/2	130.2	101.60	17.5	40.5	51.2	13.1	10.7	44.1	98.4	68.3	27.4	12	GC1108KRRB	C208	Z95573 (T40233)	2.238
RCJC	1 5/8	5 1/8	4	11/16	1 19/32	2 1/64	33/64	27/64	1 47/64	3 7/8	2 11/16	1 5/64	1/2				4.93
RCJC	1 11/16	136.5	104.78	17.5	41.3	53.2	13.1	11.9	46.8	104.8	73.0	29.4	12	GC1110KRRB	C209-2	Z955374 (T40234)	2.538
RCJC	1 3/4	5 3/8	4 1/8	1 1/16	1 5/8	2 3/32	33/64	15/32	1 27/32	4 1/8	2 7/8	1 5/32	1/2	GC1111KRRB	C209		5.59
RCJC														GC1112KRRB			
RCJC	1 15/16	142.9	111.12	15.9	42.1	54.8	17.1	12.7	48.4	112.7	79.4	30.2	16	GC1115KRRB	C210	Z956485 (T26700)	2.797
RCJC	2	5 5/8	4 3/8	5/8	1 21/32	2 5/32	43/64	1/2	1 29/32	4 7/16	3 1/8	1 3/16	5/8				6.16
RCJC	2 3/16	161.9	130.18	19.0	44.4	58.7	17.1	14.3	54.0	120.6	88.9	33.33	16	GC1200KRRB	C211	Z956423 (T26712)	4.036
RCJC														GC1203KRRB			8.89
RCJC	2 7/16	174.6	142.88	19.0	47.6	65.9	16.3	18.3	60.3	136.5	95.2	37.3	16	GC1207KRRB	C212	Z955344 (T26727)	4.926
RCJC																	10.85
RCJC	2 15/16	196.8	152.40	22.2	54.0	75.4	19.8	21.4	70.6	161.9	114.3	43.7	16	GC1215KRRB	C215	Z956555 (T27128)	7.473
RCJC																	16.46

NOTE: Shaft diameter with an S = smaller housing.

YCJ INDUSTRIAL SET SCREW SERIES

- The same basic design as the RCJ series, except specially designed set screws are used as the locking device instead of an eccentric collar.
- All units are equipped with GY-KRRB wide-inner-ring set screw bearings.
- Spherical outside diameter of the bearings mounted in the corresponding machined housing seats provides the initial self-alignment.
- Bolt-hole spacing dimensions are interchangeable with the RCJ series and most competitive units.
- Units are factory-prelubricated, but a grease fitting is provided for relubrication if required.
- Premium Shaft Guarding Technology™ option reduces replacement time, provides shaft protection and prolongs the life of the shaft.
- Safety end caps are available for selected sizes.

Suggested shaft tolerances:

1/2 in. – 1 15/16 in., nominal to -0.013 mm, -0.0005 in.;
 2 in. – 2 15/16 in., nominal to -0.025 mm, -0.0010 in.

To order bearing with Shaft Guarding Technology™, specify bearing number followed by "SGT".

Example: YCJ 1 1/2 SGT

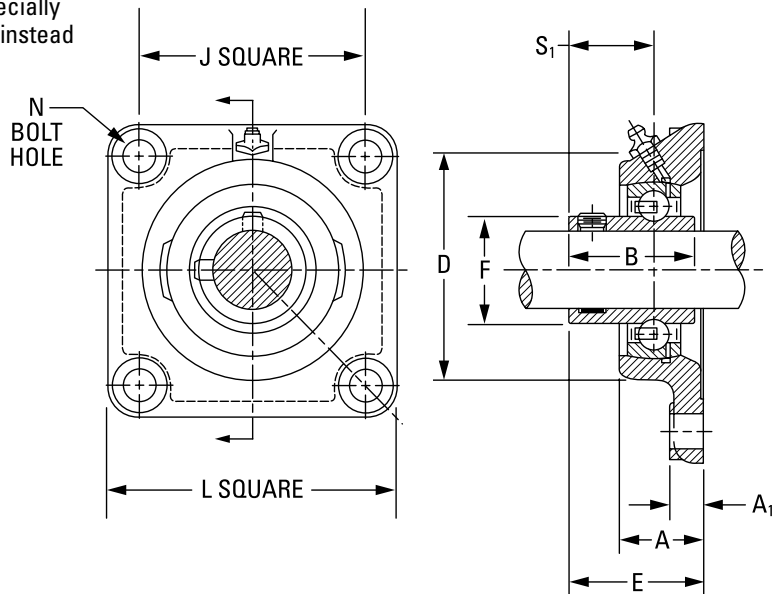

BEARING DATA

Unit	Bearing No.	Dimensions and Load Ratings
YCJ	GY-KRRB	Page 46

Unit	Shaft Dia.	L	J	A ₁	A	E	N	B	D	F	S ₁	Bolt Size	Bearing No.	Housing No.	Unit Wt.
	in. mm	mm in.	mm in.	mm in.	mm in.	mm in.	mm in.	mm in.	mm in.	mm in.	mm in.	mm in.			kg lbs.
YCJ	1/2	76.2	54.0	10.3	23.6	32.50	10.72	27.40	52.4	23.90	15.9	10	GY1008KRRB	CJ 40MM	0.454
YCJ	5/8	3	2 1/8	13/32	0.929	1.296	27/64	1 5/64	2 1/16	0.941	5/8	10	GY1010KRRB	CJ 40MM	1.001
YCJ ⁽¹⁾	3/4	85.7	63.5	11.1	27.8	37.70 ⁽²⁾	10.72	31.00 ⁽²⁾	60.3	27.56	18.3 ⁽²⁾	10	GY1012KRRB ⁽¹⁾	CJ 47MM	0.600
YCJ ⁽¹⁾	20	3 3/8	2 1/2	7/16	1.094	1.484	27/64	1 1/32	2 3/8	1.085	23/32	10	GYE20KRRB ⁽¹⁾	CJ 47MM	1.322
YCJ ⁽¹⁾	7/8												GY1014KRRB ⁽¹⁾		
YCJ ⁽¹⁾	15/16	95.2	69.9	12.8	27.9	39.30 ⁽²⁾	11.51	34.10 ⁽²⁾	65.1	33.88	19.9 ⁽²⁾	10	GY1015KRRB ⁽¹⁾	CJ 52MM	0.838
YCJ ⁽¹⁾	1	3 3/4	2 3/4	1/2	1.100	1.546	29/64	1 11/32	2 9/16	1.331	25/32	10	GY1100KRRB ⁽¹⁾	CJ 52MM	1.848
YCJ ⁽¹⁾	25												GYE25KRRB ⁽¹⁾		
YCJ ⁽¹⁾	1 1/8												GY1102KRRB ⁽¹⁾		
YCJ ⁽¹⁾	1 3/16	108.0	82.6	13.5	29.9	42.40 ⁽³⁾	11.51	38.10 ⁽³⁾	76.2	40.31	22.2 ⁽³⁾	10	GY1103KRRB ⁽¹⁾	CJ 62MM	1.131
YCJ	1 1/4 S	4 1/4	3 1/4	17/32	1.178	1.671	29/64	1 1/2	3	1.587	7/8	10	GY1103KRRB3	CJ 62MM	2.494
YCJ ⁽¹⁾	30												GYE30KRRB ⁽¹⁾		
YCJ ⁽¹⁾	1 1/4												GY1104KRRB ⁽¹⁾		
YCJ ⁽¹⁾	1 3/8	117.5	92.1	13.5	31.9	46.40 ⁽⁴⁾	13.10	42.90 ⁽⁴⁾	88.9	46.81	25.4 ⁽⁴⁾	12	GY1106KRRB ⁽¹⁾	CJ 72MM	1.623
YCJ ⁽¹⁾	1 7/16	4 5/8	3 5/8	17/32	1.254	1.827	33/64	1 11/16	3 1/2	1.843	1	12	GY1107KRRB ⁽¹⁾	CJ 72MM	3.578
YCJ ⁽¹⁾	35												GYE35KRRB ⁽¹⁾		
YCJ ⁽¹⁾	1 1/2	130.2	101.6	14.3	38.1	54.40	13.10	49.20	98.4	52.27	30.2	12	GY1108KRRB ⁽¹⁾	CJ 80MM	2.047
YCJ ⁽¹⁾	40	5 1/8	4	9/16	1.500	2.141	33/64	1 15/16	3 7/8	2.058	1 3/16	12	GYE40KRRB ⁽¹⁾	CJ 80MM	4.514

NOTE: Shaft diameter with an S = Smaller housing.
⁽¹⁾Shaft Guard Technology available
⁽²⁾Inner Ring with SGT is wider by 0.737mm [0.029 in.]
⁽³⁾Inner Ring with SGT is wider by 1.016mm [0.040 in.]
⁽⁴⁾Inner Ring with SGT is wider by 2.540mm [0.100 in.]
⁽⁵⁾Inner Ring with SGT is wider by 1.143mm [0.045 in.]

Continued on next page.

MOUNTED BALL BEARINGS

CAST-IRON FLANGED UNITS • YCJ

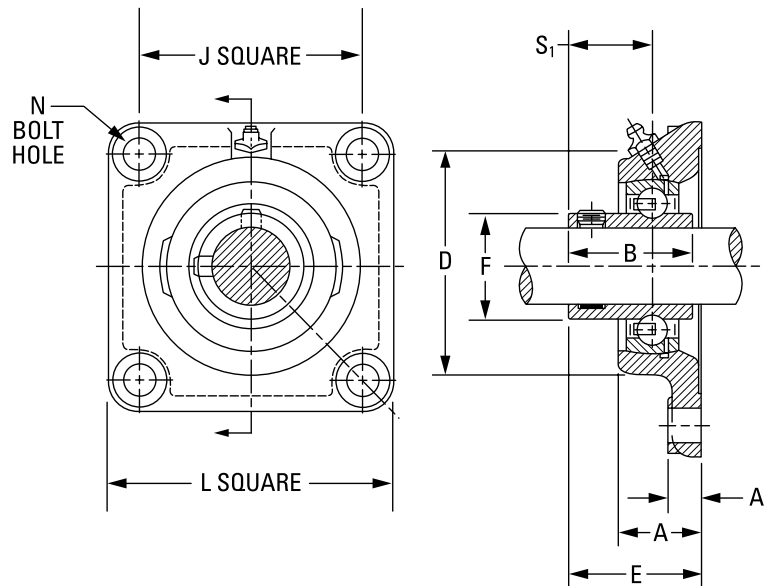

Continued from previous page.

Unit	Shaft Dia.	L	J	A ₁	A	E	N	B	D	F	S ₁	Bolt Size	Bearing No.	Housing No.	Unit Wt.
															kg lbs.
YCJ ⁽¹⁾	1 5/8														
YCJ ⁽¹⁾	1 11/16	136.5	104.8	14.3	38.9	54.40⁽⁵⁾	13.10	49.20⁽⁵⁾	104.8	57.92	30.2⁽⁵⁾	12	GY1110KRRB ⁽¹⁾ GY1111KRRB ⁽¹⁾ GY1112KRRB ⁽¹⁾	CJ 85MM	2.347 5.176
YCJ ⁽¹⁾	1 3/4	5 3/8	4 1/8	9/16	1.531	2.141	33/64	1 15/16	4 1/8	2.279	1 3/16	1/2	GYE45KRRB ⁽¹⁾		
YCJ ⁽¹⁾	45														
YCJ ⁽¹⁾	1 15/16														
YCJ	2 S	142.9	111.1	14.3	42.9	60.70	17.07	51.60	112.7	62.84	32.5	16	GY1115KRRB ⁽¹⁾ GY1115KRRB3 GYE50KRRB ⁽¹⁾	CJ 90MM	2.745 6.052
YCJ ⁽¹⁾	50	5 5/8	4 3/8	9/16	1.688	2.390	43/64	2 1/32	4 7/16	2.473	1 9/32	5/8			
YCJ ⁽¹⁾	2														
YCJ ⁽¹⁾	2 3/16	161.9	130.2	16.7	46.8	64.70	17.07	55.60	120.7	69.77	33.3	16	GY1200KRRB ⁽¹⁾ GY1203KRRB ⁽¹⁾ GY1204KRRB ⁽¹⁾	CJ 100MM	3.363 7.416
YCJ ⁽¹⁾	2 1/4	6 3/8	5 1/8	2 1/32	1.844	2.546	43/64	2 3/16	4 3/4	2.747	1 5/16	5/8	GYE55KRRB ⁽¹⁾		
YCJ ⁽¹⁾	55														
YCJ ⁽¹⁾	2 7/16	174.6	142.9	17.5	49.2	74.20	17.07	65.10	136.5	76.48	39.1	16	GY1207KRRB ⁽¹⁾ GYE60KRRB ⁽¹⁾	CJ 110MM	4.584 10.108
YCJ ⁽¹⁾	60	6 7/8	5 5/8	1 1/16	1.937	2.921	43/64	2 9/16	5 3/8	3.011	1 9/16	5/8			
YCJ	2 11/16	187.3	149.2	19.0	63.5	81.40	17.07	69.90	152.4	86.92	42.9	16	GY1211KRRB ⁽¹⁾ GYE70KRRB ⁽¹⁾	CJ 125MM	6.610 14.576
YCJ	70	7 3/8	5 7/8	3/4	2.500	3.204	43/64	2 3/4	6	3.422	1 11/16	5/8			
YCJ	2 15/16	196.8	152.4	22.2	66.7	86.20	19.84	77.80	161.9	91.92	44.4	20	GY1215KRRB ⁽¹⁾ GYE75KRRB ⁽¹⁾	CJ 130MM	8.157 17.987
YCJ	75	7 3/4	6	7/8	2.625	3.392	25/32	3 1/16	6 3/8	3.619	1 3/4	3/4			

NOTE: Shaft diameter with an S = Smaller housing.

⁽¹⁾Shaft Guard Technology available

⁽²⁾Inner Ring with SGT is wider by 0.737mm [0.029 in.]

⁽³⁾Inner Ring with SGT is wider by 1.016mm [0.040 in.]

⁽⁴⁾Inner Ring with SGT is wider by 2.540mm [0.100 in.]

⁽⁵⁾Inner Ring with SGT is wider by 1.143mm [0.045 in.]

VCJ STANDARD SERIES

- The flange cartridges come assembled and ready for mounting by using four bolts through the flange.
- The VCJ-series flange cartridges require minimal machining.
- The units are assembled with GRA-RRB bearings with positive-contact, land-riding seals and self-locking collars.
- The units are factory-prelubricated, but a grease fitting is provided for relubrication if required.
- Safety end caps are available for selected sizes.

Suggested shaft tolerances:

1/2 in. – 1 15/16 in., nominal to -0.013 mm, -0.0005 in.;

2 in. – 2 3/16 in., nominal to -0.025 mm, -0.0010 in.

To order, specify UNIT and SHAFT DIAMETER.

Example: VCJ 1 in.

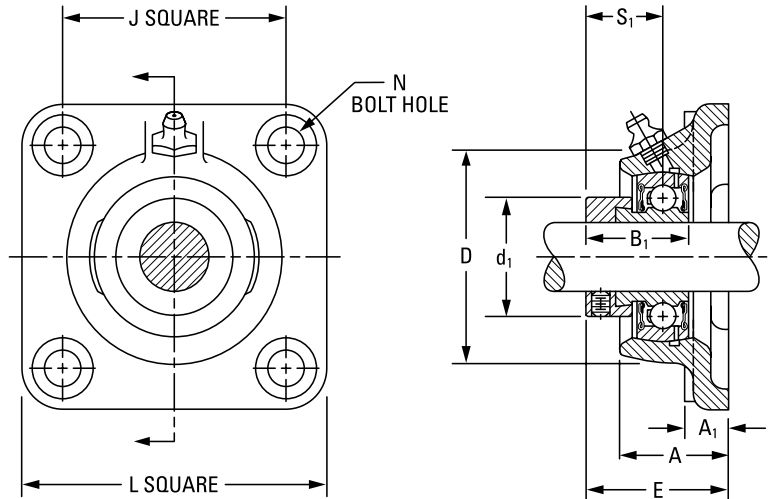

BEARING DATA

Unit	Bearing No.	Dimensions and Load Ratings
VCJ	GRA-RRB	Page 52

Unit	Shaft Dia.	Dimensions										Bolt Size	Bearing No.	Collar No.	Housing No. New (Old)	Unit Wt.	
		L	J	A ₁	A	E	N	B ₁	D	d ₁	S ₁						
	in. mm	mm in.	mm in.	mm in.	mm in.	mm in.	mm in.	mm in.	mm in.	mm in.	mm in.	mm in.	mm in.				kg lbs.
VCJ	1/2													GRA008RRB	S1008K		
VCJ	5/8	76.2	53.98	10.3	23.6	39.3	10.7	28.6	52.4	28.1	22.2	10	3/8	GRA010RRB	S1010K	Z955368 (T40228)	0.527
VCJ	17	3	2 1/8	13/32	0.929	1.548	27/64	1 1/8	2 1/16	1.105	7/8			GRAE17RRB	SE17K		1.16
VCJ	3/4	85.7	63.50	11.1	27.8	43.3	10.7	31.0	60.3	32.8	23.4	10	3/8	GRA012RRB	S1012K	Z955369 (T40229)	0.654
VCJ	20	3 3/8	2 1/2	7/16	1.094	1.706	27/64	1 7/32	2 3/8	1.292	59/64			GRAE20RRB	SE20K		1.44
VCJ	7/8													GRA014RRB	S1014K		
VCJ	15/16	95.2	69.85	12.7	27.9	43.1	11.5	31.0	65.1	37.6	23.4	10	3/8	GRA015RRB	S1015K	Z955370 (T40230)	0.894
VCJ	1	3 3/4	2 3/4	1/2	1.100	1.696	29/64	1 1/32	2 9/16	1.480	59/64			GRA100RRB	S1100K		1.97
VCJ	25													GRAE25RRB	SE25K		
VCJ	1 1/8													GRA102RRB	S1102K		
VCJ	1 3/16	107.9	82.55	13.5	29.9	47.1	11.5	35.7	76.2	43.9	27.0	10	3/8	GRA103RRB	S1103K	Z955371 (T40231)	1.239
VCJ	1 1/4 S	4 1/4	3 1/4	17/32	1.178	1.856	29/64	1 13/32	3	1.730	1 1/16			GRA103RRB2	S1103K3		2.73
VCJ	30													GRAE30RRB	SE30K		
VCJ	1 1/4													GRA104RRB	S1104K		
VCJ	1 3/8	117.5	92.08	13.5	31.8	50.5	13.1	38.9	88.9	53.6	29.4	12	1/2	GRA106RRB	S1106K	Z955372 (T40232)	1.707
VCJ	1 7/16	4 5/8	3 3/8	17/32	1.254	1.989	33/64	1 17/32	3 1/2	2.112	1 5/32			GRA107RRB	S1107		3.76
VCJ	35													GRAE35RRB	SE35K		
VCJ	1 1/2	130.2	101.60	14.3	38.1	58.3	13.1	43.7	98.4	58.2	32.5	12	1/2	GRA108RRB	S1108KT	Z955373 (T40233)	2.175
VCJ	40	5 1/8	4	9/16	1.500	2.297	33/64	1 23/32	3 7/8	2.292	1 9/32			GRAE40RRB	SE40K		4.79
VCJ	1 5/8													GRA110RRB	S1110K		
VCJ	1 11/16	136.5	104.78	14.3	38.9	57.0	13.1	43.7	104.8	63.0	32.5	12	1/2	GRA111RRB	S1111K	Z955374 (T40234)	2.438
VCJ	1 3/4	5 3/8	4 1/8	9/16	1.531	2.244	33/64	1 23/32	4 1/8	2.480	1 9/32			GRA112RRB	S1112K		5.37
VCJ	45													GRAE45RRB	SE45K		
VCJ	1 7/8													GRA114RRB	S1114K		
VCJ	1 15/16	142.9	111.12	14.3	42.9	61.0	17.1	43.7	112.7	69.3	32.5	16	5/8	GRA115RRB	S1115K	Z955375 (T40235)	2.788
VCJ	2 S	5 5/8	4 3/8	9/16	1.688	2.400	43/64	1 23/32	4 7/16	2.730	1 9/32			GRA115RRB2	S1115K2		6.14
VCJ	50													GRAE50RRB	SE50K		
VCJ	2	161.9	130.18	16.7	46.8	67.9	17.1	48.4	120.6	75.7	36.5	16	5/8	GRA200RRB	S1200K	Z955376 (T40236)	3.269
VCJ	2 3/16	6 3/8	5 1/8	21/32	1.844	2.672	43/64	1 29/32	4 3/4	2.980	1 7/16			GRA203RRB	S1203K		7.20
VCJ	55													GRAE55RRB	SE55K		

NOTE: Shaft diameter with an S = smaller housing.

MOUNTED BALL BEARINGS

CAST-IRON FLANGED UNITS • SCJ

SCJ STANDARD SERIES

- The flange cartridges come assembled and ready for mounting by using four bolts through the flange.
- The units are ideal for applications where minimum shaft length is required.
- The units are assembled with GYA-RRB bearings with positive-contact, land-riding seals and set screw locking.
- The units are factory-prelubricated, but a grease fitting is provided for relubrication if required.
- Safety end caps are available for selected sizes.

Suggested shaft tolerances:

- 1/2 in. – 1 15/16 in., nominal to -0.013 mm, -0.0005 in.;
- 2 in. – 2 3/16 in., nominal to -0.025 mm, -0.0010 in.

To order, specify UNIT and SHAFT DIAMETER.

Example: SCJ 1 in.

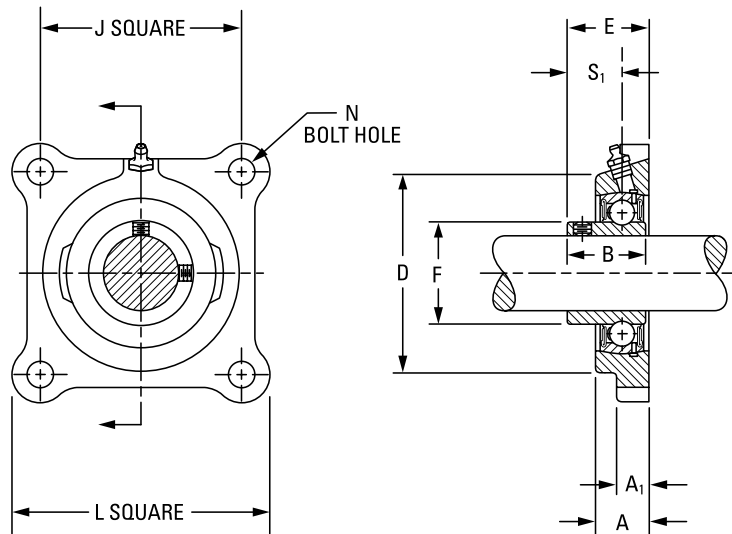

BEARING DATA

Unit	Bearing No.	Dimensions and Load Ratings
SCJ	GYA-RRB	Page 56

Unit	Shaft Dia.	Dimensions											Bolt Size	Bearing No.	Housing No. New (Old)	Unit Wt.
		L	J	A ₁	A	E	N	B	D	F	S ₁					
	in. mm	mm in.	mm in.	mm in.	mm in.	mm in.	mm in.	mm in.	mm in.	mm in.	mm in.	mm in.	mm in.			kg lbs.
SCJ	1/2													GYA008RRB		
SCJ	5/8	76.2	53.98	11.1	17.9	25.4	10.7	23.8	52.4	24.6	15.9	10	3/8	GYA010RRB	Z956491 (T40124)	0.47
SCJ	17	3	2 1/8	7/16	45/64	1	27/64	15/16	2 1/16	31/32	5/8			GYAE17RRB		1.03
SCJ	3/4	85.7	63.50	11.1	19.0	28.6	10.7	27.0	60.3	29.0	18.3	10	3/8	GYA012RRB	Z955349 (T40126)	0.52
SCJ	20	3 3/8	2 1/2	7/16	3/4	1 1/8	27/64	1 1/16	2 3/8	1 9/64	23/32			GYAE20RRB		1.14
SCJ	7/8													GYA014RRB		
SCJ	15/16	95.2	69.85	13.5	19.8	29.8	11.5	28.2	65.1	33.7	19.4	10	3/8	GYA015RRB	Z955335 (T40128)	0.68
SCJ	1	3 3/4	2 3/4	17/32	25/32	1 11/64	29/64	1 7/64	2 9/16	1 21/64	49/64			GYA100RRB		1.50
SCJ	25													GYAE25RRB		
SCJ	1 1/8													GYA102RRB		
SCJ	1 3/16	107.9	82.55	14.3	21.4	34.1	11.5	32.5	76.2	40.1	23.0	10	3/8	GYA103RRB	Z955331 (T40130)	1.19
SCJ	1 1/4 S	4 1/4	3 1/4	9/16	27/32	1 11/32	29/64	1 9/32	3	1 37/64	29/32			GYA103RRB2		2.62
SCJ	30													GYAE30RRB		
SCJ	1 1/4													GYA104RRB		
SCJ	1 3/8	117.5	92.08	15.1	24.6	38.1	13.1	36.5	88.9	46.8	25.8	12	1/2	GYA106RRB	Z955332 (T40132)	1.35
SCJ	1 7/16	4 5/8	3 5/8	19/32	31/32	1 1/2	33/64	1 7/16	3 1/2	1 27/32	1 1/64			GYA107RRB		2.98
SCJ	35													GYAE35RRB		
SCJ	1 1/2													GYA108RRB		
SCJ	40	130.2	101.60	15.9	26.2	40.9	13.1	39.3	98.4	52.4	27.8	12	1/2	GYAE40RRB	Z955324 (T40134)	2.10
		5 1/8	4	5/8	1 1/32	1 39/64	33/64	1 35/64	3 7/8	2 1/16	1 3/32					4.63
SCJ	1 5/8													GYA110RRB		
SCJ	1 11/16	136.5	104.78	15.9	28.6	43.6	13.1	42.1	104.8	57.9	28.6	12	1/2	GYA111RRB	Z955341 (T40164)	2.24
SCJ	1 3/4	5 3/8	4 1/8	5/8	1 1/8	1 23/32	33/64	1 21/32	4 1/8	2 9/32	1 1/8			GYA112RRB		4.94
SCJ	45													GYAE45RRB		
SCJ	1 15/16													GYA115RRB		
SCJ	2 S	142.9	111.12	16.7	28.6	46.0	17.1	44.4	112.7	62.6	30.9	16	5/8	GYA115RRB2	Z956406 (T40166)	2.55
SCJ	50	5 5/8	4 3/8	21/32	1 1/8	1 13/16	43/64	1 3/4	4 7/16	2 15/32	1 7/32			GYAE50RRB		5.63
SCJ	2													GYA200RRB		
SCJ	2 3/16	161.9	130.18	18.2	30.9	48.0	17.1	46.4	120.6	69.8	31.7	16	5/8	GYA203RRB	Z955346 (T40168)	2.96
SCJ	55	6 3/8	5 1/8	23/32	1 7/32	1 57/64	43/64	1 53/64	4 3/4	2 3/4	1 1/4			GYAE55RRB		6.53

NOTE: Shaft diameter with an S = smaller housing.

RCJO, LCJO HEAVY SERIES

- The flange cartridges are similar in design to the standard series.
- The units are ideal for applications where minimum machining is to be done.
- The units come assembled and ready for mounting by using four bolts through the flange.
- The RCJO units are assembled with GN-KRRB (R-seal) wide-inner-ring bearings. LCJO units are equipped with GN-KLLB (L-seal) wide-inner-ring ball bearings.
- The units are factory-prelubricated, but a grease fitting is provided for relubrication if required.
- The units are supplied with self-locking collars and are dimensionally interchangeable.

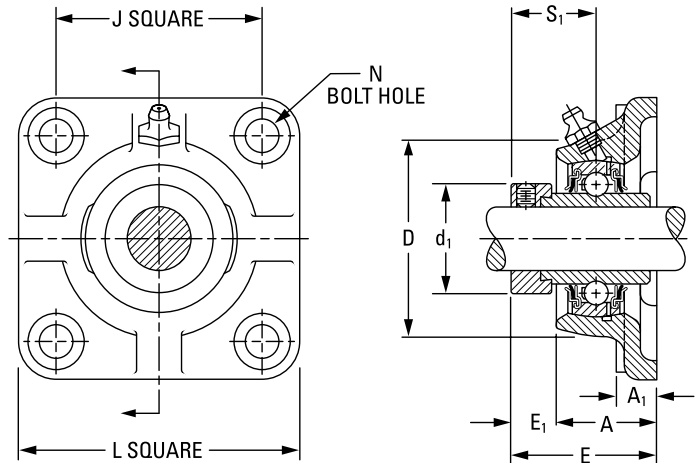

Suggested shaft tolerances:

- 1 3/16 in. – 1 15/16 in., nominal to -0.013 mm, -0.0005 in.;
- 2 in. – 3 15/16 in., nominal to -0.025 mm, -0.0010 in.

To order, specify UNIT and SHAFT DIAMETER.

Example: RCJO 1 7/16 in., LCJO 1 11/16 in.

BEARING DATA

Unit	Bearing No.	Dimensions and Load Ratings
RCJO	GN-KRRB	Page 59
LCJO	GN-KLLB	Page 61

Unit	Shaft Dia.	Dimensions										Bolt Size	Bearing No.		Collar No.	Housing No. New (Old)	Unit Wt. kg lbs.
		L	J	A ₁	A	E	N	E ₁	S ₁	D	d ₁		RCJO	LCJO			
	in.	mm in.	mm in.	mm in.	mm in.	mm in.	mm in.	mm in.	mm in.	mm in.	mm in.	mm in.					
RCJO, LCJO	1 3/16	120.6	92.1	14.3	38.1	53.7	14.3	15.1	32.5	96.8	48.7	12	GN103KRRB (KLLB)	SN103K	Z956496 (T19165)	1.816	4.00
RCJO, LCJO	1 1/4	4 3/4	3 5/8	9/16	1.500	2.115	9/16	1 9/32	1 9/32	3 13/16	1.918	1/2	GN104KRRB (KLLB)	SN103K2			
RCJO, LCJO	1 3/8	130.2	101.6	15.9	40.5	55.3	14.3	14.3	33.3	104.8	55.1	12	GN106KRRB (KLLB)	SN106K	Z956506 (T19167)	2.497	5.50
RCJO, LCJO	1 7/16	5 1/8	4	5/8	1.594	2.177	9/16	9/16	1 5/16	4 1/8	2.168	1/2	GN107KRRB (KLLB)	SN107			
RCJO, LCJO	1 1/2	136.5	104.8	15.9	44.4	60.8	15.9	15.9	37.3	114.3	63.0	14	GN108KRRB (KLLB)	SN108K	Z956521 (T19169)	3.133	6.90
RCJO, LCJO	1 11/16	142.9	111.1	17.5	46.8	62.4	15.9	15.1	38.9	123.8	69.3	14	GN111KRRB (KLLB)	SN111K	Z956544 (T19171)	3.573	7.87
RCJO, LCJO	1 3/4	5 5/8	4 3/8	1 1/16	1.844	2.458	5/8	1 17/32	1 17/32	4 7/8	2.730	9/16	GN112KRRB (KLLB)	SN112K			
RCJO	1 15/16	165.1	130.2	17.5	53.2	70.4	17.5	16.7	42.1	141.3	75.7	16	GN115KRRB	SN115K	Z955329 (T19173)	5.185	11.42
RCJO	2	6 1/2	5 1/8	1 1/16	2.094	2.771	1 1/16	2 1/32	1 2 1/32	5 9/16	2.980	5/8	GN200KRRB	SN115K2			
RCJO	2 3/16	177.8	142.9	17.5	58.7	76.7	17.5	17.5	45.2	154.0	82.0	16	GN203KRRB	SN203K	Z955339 (T19175)	6.424	14.15
RCJO	2 7/16	190.5	149.2	19.0	65.1	84.7	20.6	19.0	48.4	160.3	88.4	20	GN207KRRB	SN207K	Z956412 (T19177)	7.409	16.32
RCJO	2 1/16	225.4	177.8	22.2	72.2	89.4	23.8	21.4	54.8	185.7	101.1	22	GN211KRRB	SO211K	Z956537 (T9179)	9.534	21.00
RCJO	2 15/16	231.8	184.2	22.2	77.8	105.3	23.8	27.0	62.7	198.4	112.2	22	GN215KRRB	SN215K	Z956476 (T19181)	14.128	31.12
RCJO	3 7/16	279.4	215.9	28.6	84.1	121.2	27.0	36.5	73.8	228.6	132.3	24	GN307KRRB	SN307K	Z956567 (T24475)	21.474	47.30
RCJO	3 15/16	317.5	241.3	31.8	96.8	133.6	30.2	36.5	78.6	266.7	145.5	27	GN315KRRB	SN315K	Z956667 (T24477)	30.645	67.50

YCJM MEDIUM-DUTY SERIES SET SCREW LOCK

- This series includes four-bolt flanged cartridges featuring GYM-KRRB bearing inserts.
- This series is ideal for conveyor, fan and blower, sawmill, and feed and grain-handling applications.
- The durable cast-iron housings are powder-coated and maintain an excellent finish while resisting corrosion, chemicals and weather exposure.
- The industrial-duty flanged cartridges incorporate premium features designed to extend bearing life.

Suggested shaft tolerances:

- 1 in. – 1 ¹⁵/₁₆ in., nominal to -0.013 mm, -0.0005 in.;
- 2 in. – 3 ¹⁵/₁₆ in., nominal to -0.025 mm, -0.0010 in.

To order, specify UNIT and SHAFT DIAMETER.

Example: YCJM 1 ⁷/₁₆ in.

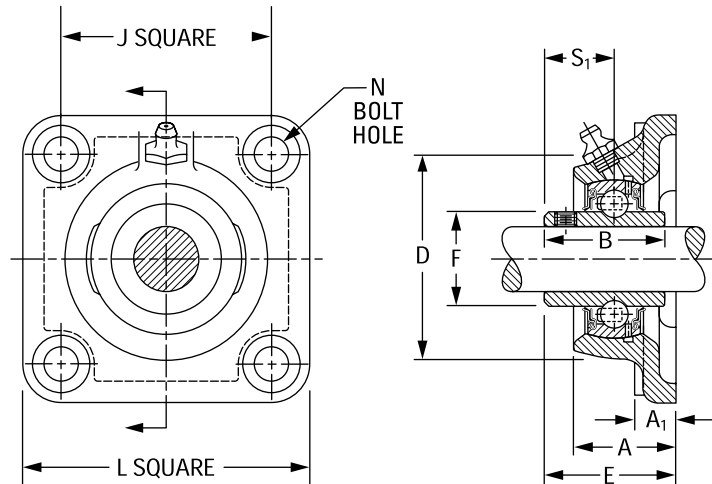

BEARING DATA

Unit	Bearing No.	Dimensions and Load Ratings
YCJM	GYM-KRRB	Page 58

Unit	Shaft Dia.	Dimensions and Load Ratings											Bolt Size	Bearing No.	Housing No. New (Old)
		L	J	A ₁	A	E	N	B	D	F	S ₁				
	in.	mm in.	mm in.	mm in.	mm in.	mm in.	mm in.	mm in.	mm in.	mm in.	mm in.	mm in.			
YCJM	1	107.9 4 1/4	82.6 3 1/4	13.5 17/32	29.9 1.178	42.4 1.671	11.51 29/64	38.10 1 1/2	76.2 3	40.31 1.587	22.2 7/8	10 3/8	GYM1100KRRB	Z955371 (T40231)	
YCJM	1 3/16	117.5 4 5/8	92.1 3 5/8	13.5 17/32	31.8 1.254	46.4 1.827	13.10 33/64	42.90 1 11/16	88.9 3 1/2	46.81 1.843	25.4 1	12 1/2	GYM1103KRRB	Z955372 (T40232)	
YCJM	1 7/16	130.2 5 1/8	101.6 4	14.8 9/16	38.1 1.500	54.4 2.141	13.10 33/64	49.20 1 15/16	98.4 3 7/8	52.27 2.058	30.2 1 3/16	12 1/2	GYM1107KRRB	Z955373 (T40233)	
YCJM	1 1/2	136.5 5 3/8	104.8 4 1/8	14.3 9/16	38.9 1.531	54.4 2.141	13.10 33/64	49.20 1 15/16	104.8 4 1/8	57.92 2.280	30.2 1 3/16	12 1/2	GYM1108KRRB	Z955374 (T40234)	
YCJM	1 11/16	142.9 5 9/8	111.1 4 3/8	14.3 9/16	42.9 1.688	60.7 2.390	17.07 43/64	51.60 2 1/32	112.7 4 7/16	62.84 2.474	32.5 1 9/32	16 5/8	GYM1111KRRB GYM1112KRRB	Z955375 (T40235)	
YCJM	1 15/16	161.9 6 3/8	130.2 5 1/8	16.7 21/32	46.8 1.844	64.7 2.546	17.07 43/64	55.60 2 3/16	120.7 4 3/4	69.77 2.747	33.3 1 15/16	16 5/8	GYM1115KRRB GY1200KRRB	Z955376 (T40236)	
YCJM	2 3/16	174.6 6 7/8	142.9 5 5/8	17.5 11/16	49.2 1.937	74.3 2.926	17.07 43/64	65.10 2 9/16	136.5 5 3/8	76.48 3.011	39.1 1 9/16	16 5/8	GYM1203KRRB GY1204KRRB	Z955316 (T40237)	
YCJM	2 7/16	187.3 7 3/8	149.2 5 7/8	19.0 3/4	63.5 2.500	81.5 3.208	17.07 43/64	69.90 2 3/4	152.4 6	86.92 3.422	42.9 1 11/16	16 5/8	GYM1207KRRB GYM1208KRRB	Z956389 (T22530)	
YCJM	2 11/16	196.8 7 3/4	152.4 6	22.2 7/8	66.7 2.625	86.2 3.396	19.84 25/32	77.80 3 1/16	161.9 6 3/8	91.92 3.619	44.4 1 3/4	20 3/4	GYM1211KRRB	Z955323 (T21620)	
YCJM	2 15/16	196.8 7 3/4	152.4 6	22.2 7/8	66.7 2.625	90.8 3.576	19.84 25/32	77.80 3 1/16	179.4 7 1/16	98.37 3.873	44.4 1 15/16	20 3/4	GYM1215KRRB GYM1300KRRB	Z956390 (T90063)	
YCJM	3 7/16	214.3 8 7/16	171.4 6 3/4	25.4 1	70.5 2.776	101.1 3.981	19.84 25/32	95.94 3 25/32	196.8 7 3/4	111.68 4.397	56.4 2 7/32	20 3/4	GYM1307KRRB	Z956518 (M81160)	
YCJM	3 15/16	268.3 10 9/16	211.1 8 5/16	31.8 1 1/4	95.4 3.755	127.3 5.014	26.19 1 1/32	117.35 4 5/8	235.0 9 1/4	131.30 5.171	68.3 2 11/16	24 1	GYM1315KRRB	Z956607 (M81153)	

YCJTM MEDIUM-DUTY SERIES SET SCREW LOCK

- The medium-duty, two-bolt flanged cartridges feature GYM-KRRB bearing inserts.
- This series is ideal for conveyor, fan and blower, sawmill, and feed and grain-handling applications.
- The durable cast-iron housings are powder-coated and maintain an excellent finish while resisting corrosion, chemicals and weather exposure.
- The industrial-duty flanged cartridge units incorporate premium features designed to extend bearing life. They can replace competitive designs.

Suggested shaft tolerances:

- 1 – 1 15/16 in., nominal to -0.013 mm, -0.0005 in.;
- 2 in., nominal to -0.025 mm, -0.0010 in.

To order, specify UNIT and SHAFT DIAMETER.

Example: YCJTM 1 7/16 in.

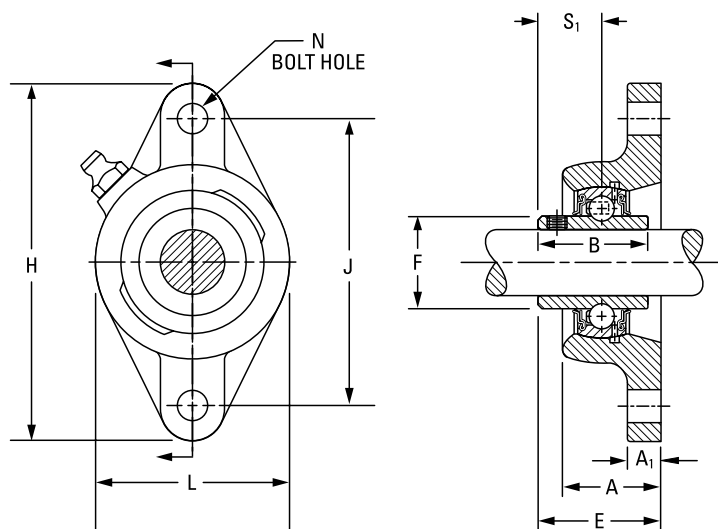

BEARING DATA

Unit	Bearing No.	Dimensions and Load Ratings
YCJTM	GYM-KRRB	Page 58

Unit	Shaft Dia.	Dimensions										Bolt Size	Bearing No.	Housing No. New (Old)
		H	J	L	A	E	N	B	A ₁	F	S ₁			
	in.	mm in.	mm in.	mm in.	mm in.	mm in.	mm in.	mm in.	mm in.	mm in.	mm in.	mm in.		
YCJTM	1	141.3	116.7	79.5	29.9	42.4	11.51	38.1	13.5	40.31	22.2	10	GYM1100KRRB	Z955380
YCJTM	1 SGT	5 9/16	4 19/32	3 1/8	1.178	1.671	29/64	1 1/2	17/32	1.587	7/8	3/8	GYM1100KRRB SGT	(T40222)
YCJTM	1 3/16	155.6	130.2	92.1	31.8	46.4	13.10	42.9	11.9	46.79	25.4	12	GYM1103KRRB	Z955381
YCJTM	1 3/16 SGT	6 1/8	5 1/8	3 5/8	1.254	1.827	33/64	1 11/16	19/32	1.843	1	1/2	GYM1103KRRB SGT	(T40252)
YCJTM	1 7/16	171.5	143.7	104.8	38.1	54.4	13.10	49.2	12.7	52.27	30.2	12	GYM1107KRRB	Z955382
YCJTM	1 7/16 SGT	6 3/4	5 21/32	4 1/8	1.500	2.141	33/64	1 15/16	1/2	2.058	1 3/16	1/2	GYM1107KRRB SGT	(T40224)
YCJTM	1 1/2	179.4	148.4	111.1	38.9	54.4	13.10	49.2	12.7	57.92	30.2	12	GYM1108KRRB	Z955383
YCJTM	1 1/2 SGT	7 1/16	5 27/32	4 3/8	1.531	2.141	33/64	1 15/16	1/2	2.280	1 3/16	1/2	GYM1108KRRB SGT	(T40225)
YCJTM	1 11/16	188.9	157.2	115.9	42.9	60.7	17.07	51.6	12.7	62.81	32.5	16	GYM1111KRRB	Z955384
YCJTM	1 11/16 SGT	7 7/16	6 3/16	4 9/16	1.688	2.390	43/64	2 1/32	1/2	2.473	1 9/32	5/8	GYM1111KRRB SGT	(T40226)
YCJTM	1 3/4												GYM1112KRRB	
YCJTM	1 15/16												GYM1115KRRB	
YCJTM	1 15/16 SGT	215.9	184.2	127.0	46.8	64.7	17.07	55.6	16.7	69.77	33.3	16	GYM1115KRRB SGT	Z955385
YCJTM	2	8 1/2	7 1/4	5	1.844	2.546	43/64	2 3/16	21/32	2.747	1 15/16	5/8	GYM1200KRRB	(T40227)
YCJTM	2 SGT												GYM1200KRRB SGT	

MOUNTED BALL BEARINGS

CAST-IRON FLANGED UNITS • RCJT, TCJT, LCJT

RCJT, TCJT, LCJT INDUSTRIAL SERIES

- The cartridges are the same basic design as RCJ, TCJ, and LCJ types, except they have two bolt holes instead of four.
- This series is primarily designed for applications where the mounting area is restricted.
- The RCJT cartridge is equipped with G-KRRB (R-seal) wide-inner-ring ball bearings. The TCJT is equipped with G-KPPB (tri-ply seal) wide-inner-ring ball bearings. The LCJT is equipped with the G-KLLB (Mechani-seal) wide-inner-ring ball bearings.
- The units are factory-prelubricated, but a grease fitting is provided for relubrication.
- Safety end caps are available for selected sizes.

Suggested shaft tolerances:

- 1/2 in. – 1 15/16 in., nominal to -0.013 mm, -0.0005 in.;
- 2 in. – 2 3/16 in., nominal to -0.025 mm, -0.0010 in.

To order, specify UNIT and SHAFT DIAMETER.

Example: RCJT 1 3/16 in., TCJT 1 3/16 in.

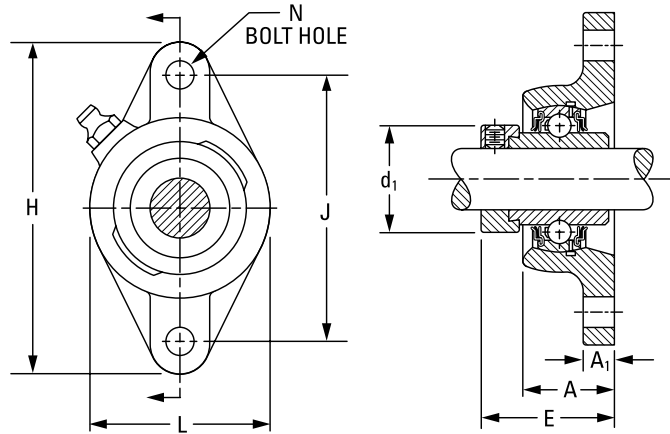

BEARING DATA

Unit	Bearing No.	Dimensions and Load Ratings
RCJT	G-KRRB	Page 36
TCJT	G-KPPB	Page 41
LCJT	G-KLLB	Page 39

Unit	Shaft Dia.	Dimensions									Bolt Size	Bearing No.			Collar No.	Housing No. New (Old)	Unit Wt.
		H	J	L	A	N	E	A ₁	d ₁	RCJT		TCJT	LCJT				
	in. mm	mm in.	mm in.	mm in.	mm in.	mm in.	mm in.	mm in.	mm in.	mm in.						kg lbs.	
RCJT	1/2											G1008KRRB			S1008K		
RCJT	5/8	98.4	76.2	54.0	23.6	10.7	40.6	10.3	28.1	10		G1010KRRB			S1010K	Z955377	0.590
RCJT	1 1/16	3 7/8	3	2 1/8	0.929	27/64	1.599	13/32	1.105	3/8		G1011KRRB			S1011K	(T40219)	1.30
RCJT	17											GE17KRRB			SE17K		
RCJT	3/4	111.9	89.7	60.5	27.8	10.7	46.4	11.1	32.8	10		G1012KRRB			S1012K	Z955378	0.590
RCJT	20	4 13/32	3 17/32	2 3/8	1.094	27/64	1.828	7/16	1.292	3/8		GE20KRRB			SE20K	(T40220)	1.30
RCJT, TCJT, LCJT	13/16											G1013KRRB	G1013KPPB3	G1013KLLB	S1013K		
RCJT, TCJT, LCJT	7/8	123.8	99.2	69.8	27.9	11.5	46.7	11.1	23.9	10		G1014KRRB	G1014KPPB3	G1014KLLB	S1014K	Z955379	0.785
RCJT, TCJT, LCJT	15/16	4 7/8	3 29/32	2 3/4	1.100	29/64	1.839	7/16	1.480	3/8		G1015KRRB	G1015KPPB3	G1015KLLB	S1015K	(T40221)	1.73
RCJT, TCJT, LCJT	1											G1100KRRB	G1100KPPB3	G1100KLLB	S1100K		
RCJT, TCJT, LCJT	25											GE25KRRB	GE25KPPB3	GE25KLLB	SE25K		
RCJT, TCJT, LCJT	1 1/16											G1101KRRB	G1101KPPB3	G1101KLLB	S1101K		
RCJT, TCJT, LCJT	1 1/8	141.3	116.7	79.4	29.9	11.5	50.5	11.9	43.7	10		G1102KRRB	G1102KPPB3	G1102KLLB	S1102K	Z955380	1.090
RCJT, TCJT, LCJT	1 3/16	5 9/16	4 19/32	3 1/8	1.178	29/64	1.990	15/32	1.730	3/8		G1103KRRB	G1103KPPB3	G1103KLLB	S1103K	(T40222)	2.40
RCJT, TCJT, LCJT	1 1/4 S											G1103KRRB3	G1103KPPB4	G1103KLLB3	S1103K3		
RCJT, TCJT, LCJT	30											GE30KRRB	GE30KPPB3	GE30KLLB	SE30K		
RCJT, TCJT, LCJT	1 1/4											G1104KRRB	G1104KPPB2	G1104KLLB	S1104K ⁽¹⁾		
RCJT, TCJT, LCJT	1 5/16	155.6	130.2	92.1	31.8	13.1	53.5	11.9	53.6	12		G1105KRRB	G1105KPPB2	G1105KLLB	S1105K ⁽¹⁾	Z955381	1.444
RCJT, TCJT, LCJT	1 3/8	6 1/8	5 1/8	3 5/8	1.254	33/64	2.106	15/32	2.112	1/2		G1106KRRB	G1106KPPB2	G1106KLLB	S1106K ⁽¹⁾	(T40223)	3.18
RCJT, TCJT, LCJT	1 7/16											G1107KRRB	G1107KPPB2	G1107KLLB	S1107K ⁽¹⁾		
RCJT, TCJT, LCJT	35											GE35KRRB	GE35KPPB2	GE35KLLB	SE35K		
RCJT, TCJT, LCJT	1 1/2	171.4	143.6	104.7	38.1	13.1	59.3	12.7	58.2	12		G1108KRRB	G1108KPPB3	G1108KLLB	S1108KT	Z955382	2.193
RCJT, TCJT, LCJT	1 9/16	6 3/4	5 21/32	4 1/8	1.500	33/64	2.334	1/2	2.292	1/2		G1109KRRB	G1109KPPB3	G1109KLLB	S1109KT	(T40224)	4.83
RCJT, TCJT, LCJT	40											GE40KRRB	GE40KPPB3	GE40KLLB	SE40K		
RCJT, TCJT, LCJT	1 5/8											G1110KRRB	G1110KPPB4	G1110KLLB	S1110K		
RCJT, TCJT, LCJT	1 11/16	179.4	148.0	111.1	38.9	13.1	59.3	12.7	63.0	12		G1111KRRB	G1111KPPB4	G1111KLLB	S1111K	Z955383	2.379
RCJT, TCJT, LCJT	1 3/4	7 1/16	5 27/32	4 3/8	1.531	33/64	2.334	1/2	2.480	1/2		G1112KRRB	G1112KPPB4	G1112KLLB	S1112K	(T40225)	5.24
RCJT, TCJT, LCJT	45											GE45KRRB	GE45KPPB4	GE45KLLB	SE45K		
RCJT, TCJT, LCJT	1 7/8	188.9	157.2	115.9	42.9	17.1	66.4	12.7	69.3	16		G1114KRRB	G1114KPPB3	G1114KLLB	S1114K	Z955384	2.724
RCJT, TCJT, LCJT	1 15/16	7 7/16	6 3/16	4 9/16	1.688	43/64	2.615	1/2	2.730	5/8		G1115KRRB	G1115KPPB3	G1115KLLB	S1115K	(T40226)	6.00
RCJT, TCJT, LCJT	50											GE50KRRB	GE50KPPB3	GE50KLLB	SE50K		
RCJT, TCJT, LCJT	2											G1200KRRB	G1200KPPB4	G1200KLLB	S1200K		
RCJT, TCJT, LCJT	2 1/8	215.9	184.1	127.0	46.8	17.1	75.1	16.7	75.7	16		G1202KRRB	G1202KPPB4	G1202KLLB	S1202K	Z955385	3.668
RCJT, TCJT, LCJT	2 3/16	8 1/2	7 1/4	5	1.844	43/64	2.958	21/32	2.980	5/8		G1203KRRB	G1203KPPB4	G1203KLLB	S1203K	(T40277)	8.08
RCJT, TCJT, LCJT	55											GE55KRRB	GE55KPPB4	GE55KLLB	SE55K		

⁽¹⁾Add C1 suffix to collar numbers for G-KPPB2 bearings (TCJT).

NOTE: Shaft diameter with an S = smaller housing.

RCJTC INDUSTRIAL-SERIES CONCENTRIC COLLAR

- This series has the same basic design as RCJT, except it uses the concentric collar rather than the self-locking eccentric collar as the shaft-locking device.
- All units are equipped with GC-KRRB wide inner ring concentric collars.
- The spherical outside diameter mounted in the corresponding machined housing seats provides the initial self-alignment.
- The bolt-hole spacing dimensions are interchangeable with the RCJT series and most competitive units.
- The units are factory-prelubricated. A grease fitting is provided for relubrication.
- Safety end caps are available for selected sizes.

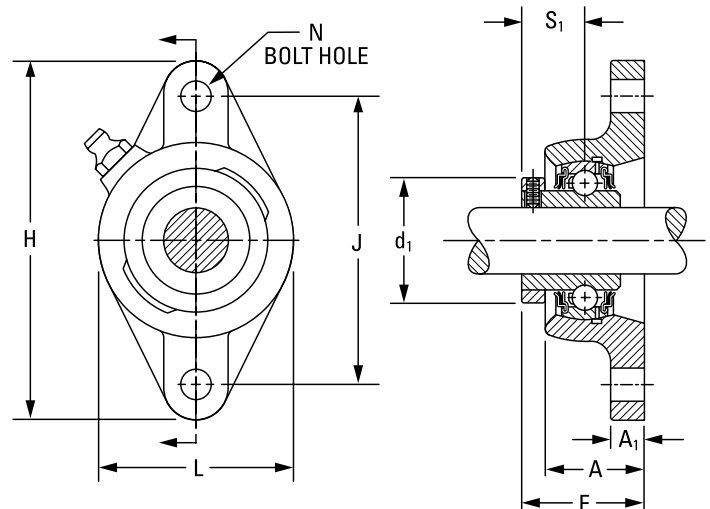

Suggested shaft tolerances:

1/2 in. – 1 15/16 in., nominal to -0.013 mm, -0.0005 in.;

To order, specify UNIT and SHAFT DIAMETER.

Example: RCJTC 1 3/16 in.

BEARING DATA

Unit	Bearing No.	Dimensions and Load Ratings
RCJTC	GC-KRRB	Page 42

Unit	Shaft Dia.	Dimensions										Bolt Size	Bearing No.	Collar No.	Housing No. New (Old)	Unit Wt.	
		H	J	L	A	E	N	A ₁	d ₁	S ₁							
	in.	mm in.	mm in.	mm in.	mm in.	mm in.	mm in.	mm in.	mm in.	mm in.	mm in.	mm in.	mm in.	mm in.	mm in.	mm in.	kg lbs.
RCJTC	1/2	98.4	76.20	60.3	23.6	32.7	9.9	8.3	33.8	15.5	10	GC1008KRRB				0.368	
RCJTC	5/8	3 7/8	3	2 3/8	0.929	1.287	25/64	2 1/64	1.329	39/64	10 3/8	GC1010KRRB	C203	Z955377 (T40219)		0.81	
RCJTC	1 1/16											GC1011KRRB					
RCJTC	3/4	111.9	89.70	60.3	27.8	38.2	9.9	11.1	37.7	18.7	10 3/8	GC1012KRRB	C204	Z956426 (T90047)		0.545	
RCJTC	7/8	4 13/32	3 17/32	2 3/8	1.094	1.502	25/64	7/16	1.485	47/64	10 3/8	GC1014KRRB					
RCJTC	15/16	123.8	98.81	69.8	27.9	39.8	11.9	13.5	44.1	20.2	10 3/8	GC1015KRRB	C205	Z955358 (T90048)		0.717	
RCJTC	1	4 7/8	3 57/64	2 3/4	1.100	1.569	15/32	17/32	1.735	51/64	10 3/8	GC1100KRRB				1.58	
RCJTC	1 1/8											GC1102KRRB					
RCJTC	1 3/16	141.3	116.70	81.0	29.9	43.0	11.5	13.5	52.3	22.6	10 3/8	GC1103KRRB	C206	Z955380 (T40222)		1.035	
RCJTC	1 1/4 S	5 9/16	4 19/32	3 3/16	1.178	1.693	29/64	17/32	2.058	57/64	10 3/8	GC1103KRRB3				2.28	
RCJTC	1 1/4											GC1104KRRB					
RCJTC	1 3/8	155.6	130.20	92.1	31.8	46.6	13.1	14.3	58.2	25.4	12 1/2	GC1106KRRB	C207	Z956470 (T27263)		1.498	
RCJTC	1 7/16	6 1/8	5 1/8	3 3/8	1.254	1.834	33/64	9/16	2.292	1	12 1/2	GC1107KRRB				3.30	
RCJTC	1 1/2											GC1108KRRB	C208	Z955382 (T40274)			
RCJTC	1 11/16	179.4	148.40	111.1	38.9	53.7	13.1	14.3	72.9	29.4	12 1/2	GC1111KRRB	C209	Z956581 (T28537)		2.097	
RCJTC	1 15/16	7 1/16	5 27/32	4 3/8	1.531	2.116	33/64	9/16	2.871	1 5/32	12 1/2					4.62	
RCJTC	1 15/16	188.9	157.20	115.9	42.9	58.5	17.1	14.3	79.3	30.2	16 5/8	GC1115KRRB	C210	Z956582 (T27286)		2.497	
RCJTC	1 15/16	7 7/16	6 3/16	4 9/16	1.688	2.303	43/64	9/16	3.121	1 3/16	16 5/8					5.50	

NOTE: Shaft diameter with an S = smaller housing.

MOUNTED BALL BEARINGS

CAST-IRON FLANGED UNITS • VCJT

VCJT STANDARD SERIES

- This series has the same design and features as the VCJ type, but has two bolt holes instead of four. This allows mounting in restricted areas.
- This series is assembled with GRA-RRB bearings with positive-contact, land-riding seals and self-locking collars.
- The units are factory-prelubricated. A grease fitting is provided for relubrication.
- Safety end caps are available for selected sizes.

Suggested shaft tolerances:

- 1/2 in. – 1 15/16 in., nominal to -0.013 mm, -0.0005 in.;
- 2 in. – 2 3/16 in., nominal to -0.025 mm, -0.0010 in.

To order, specify UNIT and SHAFT DIAMETER.

Example: VCJT 1 in.

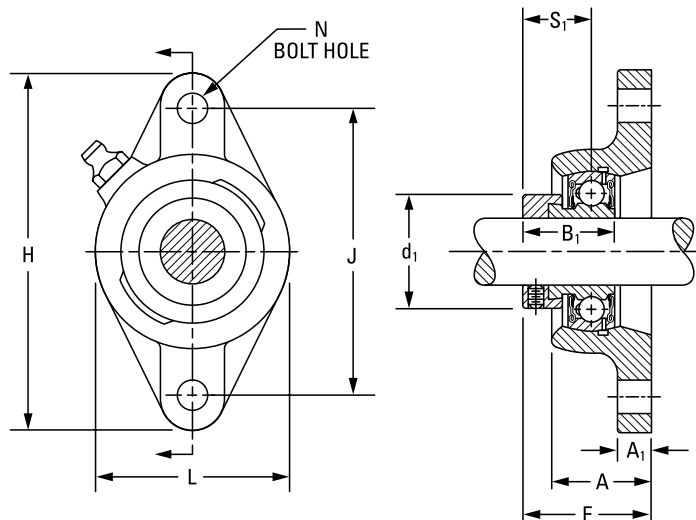

BEARING DATA

Unit	Bearing No.	Dimensions and Load Ratings
VCJT	GRA-RRB	Page 52

Unit	Shaft Dia.	Dimensions										Bolt Size	Bearing No.	Collar No.	Housing No. New (Old)	Unit Wt.	
		H	J	L	A	E	N	B ₁	A ₁	d ₁	S ₁						
	in. mm	mm in.	mm in.	mm in.	mm in.	mm in.	mm in.	mm in.	mm in.	mm in.	mm in.	mm in.					kg lbs.
VCJT	1/2	98.4	76.2	53.9	23.6	39.3	10.7	28.6	10.3	28.1	22.2	10	GRA008RRB	S1008K	Z955377	0.590	
VCJT	5/8	3 7/8	3	2 1/8	0.929	1.548	27/64	1 1/8	13/32	1.105	7/8	3/8	GRA010RRB	S1010K	(T40270)	1.30	
VCJT	17												GRAE17RRB	SE17K			
VCJT	3/4	111.9	89.7	60.3	27.8	43.3	9.9	31.0	11.1	32.8	23.4	10	GRA012RRB	S1012K	Z955378	0.518	
VCJT	20	4 13/32	3 17/32	2 3/8	1.094	1.706	25/64	1 7/32	7/16	1.292	59/64	3/8	GRAE20RRB	SE20K	(T40271)	1.44	
VCJT	7/8												GRA014RRB	S1014K			
VCJT	15/16	123.8	99.2	69.8	27.9	43.2	11.5	31.0	11.1	23.9	23.4	10	GRA015RRB	S1015K	Z955379	0.740	
VCJT	1	4 7/8	3 29/32	2 3/4	1.100	1.701	29/64	1 7/32	7/16	1.480	59/64	3/8	GRA100RRB	S1100K	(T40272)	1.63	
VCJT	25												GRAE25RRB	SE25K			
VCJT	1 1/8												GRA102RRB	S1102K			
VCJT	1 3/16	141.3	116.7	79.4	29.9	47.1	11.5	35.7	11.9	43.7	27.0	10	GRA103RRB	S1103K	Z955380	1.026	
VCJT	1 1/4 S	5 9/16	4 19/32	3 1/8	1.178	1.856	29/64	1 13/32	15/32	1.730	1 1/16	3/8	GRA103RRB2	S1103K3	(T40273)	2.26	
VCJT	30												GRAE30RRB	SE30K			
VCJT	1 1/4												GRA104RRB	S1104K			
VCJT	1 3/8	155.6	130.2	92.1	31.8	50.5	13.1	38.9	11.9	53.6	29.4	12	GRA106RRB	S1106K	Z955381	1.362	
VCJT	1 7/16	6 1/8	5 1/8	3 5/8	1.254	1.989	33/64	1 17/32	15/32	2.112	1 9/32	1/2	GRA107RRB	S1107K	(T40252)	3.00	
VCJT	35												GRAE35RRB	SE35K			
VCJT	1 1/2	171.4	143.6	104.7	38.1	56.9	13.1	43.7	12.7	58.2	32.5	12	GRA108RRB	S1108KT	Z955382	2.075	
VCJT	40	6 3/4	5 21/32	4 1/8	1.500	2.243	33/64	1 23/32	1/2	2.292	1 9/32	1/2	GRAE40RRB	SE40K	(T40274)	4.57	
VCJT	1 5/8												GRA110RRB	S1110K			
VCJT	1 11/16	179.4	148.0	111.1	38.9	57.0	13.1	43.7	12.7	63.0	32.5	12	GRA111RRB	S1111K	Z955383	2.229	
VCJT	1 3/4	7 1/16	5 27/32	4 3/8	1.531	2.244	33/64	1 23/32	1/2	2.480	1 9/32	1/2	GRA112RRB	S1112K	(T40275)	4.91	
VCJT	45												GRAE45RRB	SE45K			
VCJT	1 7/8												GRA114RRB	S1114K			
VCJT	1 15/16	188.9	157.2	115.8	42.9	61.0	17.1	43.7	12.7	69.3	32.5	16	GRA115RRB	S1115K	Z955384	2.492	
VCJT	2 S	7 7/16	6 3/16	4 9/16	1.688	2.400	43/64	1 23/32	1/2	2.730	1 9/32	5/8	GRA115RRB2	S1115K2	(T40276)	5.49	
VCJT	50												GRAE50RRB	SE50K			
VCJT	2												GRA200RRB	S1200K			
VCJT	2 3/16	215.9	184.1	127.0	46.8	67.9	17.1	48.4	16.7	75.7	36.5	16	GRA203RRB	S1203K	Z955385	3.092	
VCJT	55	8 1/2	7 1/4	5	1.844	2.672	43/64	1 29/32	21/32	2.980	2 7/16	5/8	GRAE55RRB	SE55K	(T40277)	6.81	

NOTE: Shaft diameter with an S = smaller housing.

YCJT INDUSTRIAL SET SCREW SERIES

- This series has the same design as the YCJ series, but is mounted with two bolts instead of four.
- All units are equipped with GY-KRRB wide inner ring, set screw bearings.
- The spherical outside diameter mounted in the corresponding machined housings seats provides the initial self-alignment.
- The units are factory-prelubricated. A grease fitting is provided for relubrication.
- Premium Shaft Guarding Technology™ option reduces replacement time, provides shaft protection and prolongs the life of the shaft.
- Safety end caps are available for selected sizes.

Suggested shaft tolerances:

1/2 in. – 1 15/16 in., nominal to -0.013 mm, -0.0005 in.;
 2 in. – 2 15/16 in., nominal to -0.025 mm, -0.0010 in.

To order bearing with Shaft Guarding Technology™, specify bearing number followed by "SGT".

Example: YCJT 1 1/2 SGT

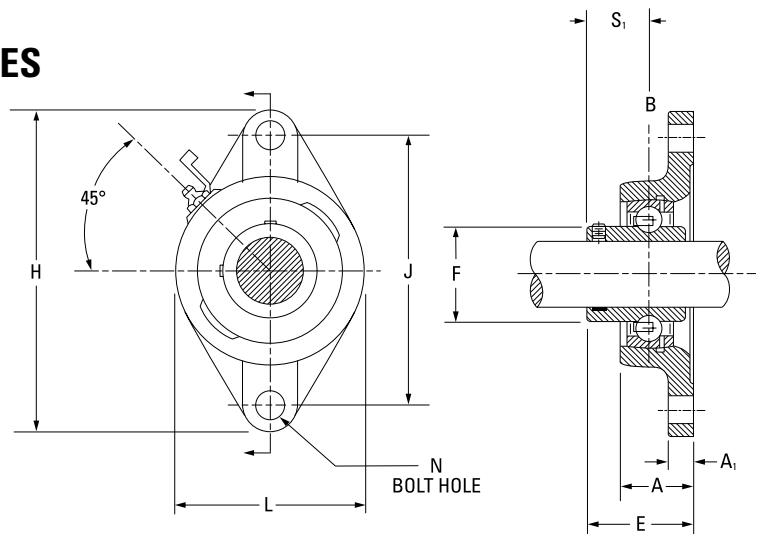

BEARING DATA

Unit	Bearing No.	Dimensions and Load Ratings
YCJT	GY-KRRB	Page 46

Unit	Shaft Dia.	H	J	L	A	E	B	A ₁	F	N	S ₁	Bolt Size	Bearing No.	Housing No.	Unit Wt.
		in.	mm	mm	mm	mm	mm	mm	mm	mm	mm				
YCJT	1/2	98.4	76.2	54.00	23.6	32.90	27.40	10.3	23.9	10.7	15.9	10	GY1008KRRB	CJT 40MM	0.415
YCJT	5/8	3 7/8	3	2 1/8	0.929	1.296	1 5/64	27/64	0.941	27/64	5/8	3/8	GY1010KRRB		0.914
YCJT ⁽¹⁾	3/4	111.9	89.7	60.50	27.8	37.70 ⁽²⁾	31.00 ⁽²⁾	11.1	27.6	10.7	18.3 ⁽²⁾	10	GY1012KRRB ⁽¹⁾	CJT 47MM	0.529
YCJT ⁽¹⁾	20	4 13/32	3 17/32	2 3/8	1.094	1.484	1 7/32	7/16	1.085	27/64	23/32	3/8	GYE20KRRB ⁽¹⁾		1.167
YCJT ⁽¹⁾	7/8	124.0	99.2	69.90	27.9	39.30 ⁽²⁾	34.10 ⁽²⁾	12.7	33.8	11.5	19.8 ⁽²⁾	12	GY1014KRRB ⁽¹⁾		
YCJT ⁽¹⁾	1 5/16	4 7/8	3 29/32	2 3/4	1.100	1.546	1 11/32	1/2	1.331	29/64	25/32	1/2	GY1015KRRB ⁽¹⁾	CJT 52MM	0.720
YCJT ⁽¹⁾	1	141.2	116.7	79.45	29.9	42.40 ⁽³⁾	38.10 ⁽³⁾	13.5	40.3	11.5	22.2 ⁽³⁾	12	GY1100KRRB ⁽¹⁾		1.587
YCJT ⁽¹⁾	25	5 9/16	4 19/32	3 1/8	1.178	1.671	1 1/2	17/32	1.587	29/64	7/8	1/2	GY1104KRRB ⁽¹⁾	CJT 62MM	1.026
YCJT ⁽¹⁾	1 1/8	155.7	130.2	92.10	31.8	46.40 ⁽⁴⁾	42.90 ⁽⁴⁾	13.5	46.8	13.1	25.4 ⁽⁴⁾	12	GY1103KRRB ⁽¹⁾		2.263
YCJT ⁽¹⁾	1 3/16	6 1/8	5 1/8	3 5/8	1.254	1.827	1 11/16	17/32	1.843	33/64	1	1/2	GY1103KRRB3	CJT 62MM	2.263
YCJT ⁽¹⁾	30	171.5	143.7	104.80	38.1	54.40	49.20	14.3	52.2	13.1	30.2	12	GYE30KRRB ⁽¹⁾		
YCJT ⁽¹⁾	1 1/4	6 3/4	5 1/8	4 1/8	1.500	2.141	1 15/16	9/16	2.057	33/64	1 3/16	1/2	GY1104KRRB ⁽¹⁾	CJT 72MM	1.382
YCJT ⁽¹⁾	1 3/8	179.3	148.4	111.10	38.9	54.40 ⁽⁵⁾	49.20 ⁽⁵⁾	14.3	57.9	13.1	30.2 ⁽⁵⁾	12	GY1106KRRB ⁽¹⁾		3.047
YCJT ⁽¹⁾	1 7/16	7 1/16	5 27/32	4 3/8	1.531	2.141	1 15/16	9/16	2.279	33/64	1 3/16	1/2	GY1107KRRB ⁽¹⁾	CJT 72MM	3.047
YCJT ⁽¹⁾	35	171.5	143.7	104.80	38.1	54.40	49.20	14.3	52.2	13.1	30.2	12	GYE35KRRB ⁽¹⁾		
YCJT ⁽¹⁾	1 1/2	179.3	148.4	111.10	38.9	54.40 ⁽⁵⁾	49.20 ⁽⁵⁾	14.3	57.9	13.1	30.2 ⁽⁵⁾	12	GY1108KRRB ⁽¹⁾	CJT 80MM	2.034
YCJT ⁽¹⁾	40	6 3/4	5 21/32	4 1/8	1.500	2.141	1 15/16	9/16	2.057	33/64	1 3/16	1/2	GY1110KRRB ⁽¹⁾		4.486
YCJT ⁽¹⁾	1 5/8	179.3	148.4	111.10	38.9	54.40 ⁽⁵⁾	49.20 ⁽⁵⁾	14.3	57.9	13.1	30.2 ⁽⁵⁾	12	GYE40KRRB ⁽¹⁾		
YCJT ⁽¹⁾	1 11/16	7 1/16	5 27/32	4 3/8	1.531	2.141	1 15/16	9/16	2.279	33/64	1 3/16	1/2	GY1110KRRB ⁽¹⁾	CJT 85MM	2.327
YCJT ⁽¹⁾	1 3/4	188.9	157.2	115.90	42.9	60.70	51.60	14.3	62.8	17.0	32.5	12	GY1111KRRB ⁽¹⁾		5.13
YCJT ⁽¹⁾	45	7 1/16	5 27/32	4 3/8	1.531	2.141	1 15/16	9/16	2.279	33/64	1 3/16	1/2	GY1112KRRB ⁽¹⁾	CJT 85MM	5.13
YCJT ⁽¹⁾	1 15/16	188.9	157.2	115.90	42.9	60.70	51.60	14.3	62.8	17.0	32.5	12	GYE45KRRB ⁽¹⁾		
YCJT ⁽¹⁾	2 S	7 7/16	6 3/16	4 9/16	1.688	2.390	2 1/32	9/16	2.473	43/64	1 9/32	1/2	GY1115KRRB ⁽¹⁾	CJT 90MM	2.616
YCJT ⁽¹⁾	50	215.9	184.2	127.00	46.8	64.70	55.60	16.7	69.7	17.0	33.3	16	GYE50KRRB ⁽¹⁾		5.769
YCJT ⁽¹⁾	2	8 1/2	7 1/4	5	1.844	2.547	2 3/16	2 1/32	2.745	43/64	1 5/16	5/8	GY1200KRRB ⁽¹⁾	CJT 100MM	3.532
YCJT ⁽¹⁾	2 3/16	215.9	184.2	127.00	46.8	64.70	55.60	16.7	69.7	17.0	33.3	16	GY1203KRRB ⁽¹⁾		7.789
YCJT ⁽¹⁾	55	8 1/2	7 1/4	5	1.844	2.547	2 3/16	2 1/32	2.745	43/64	1 5/16	5/8	GYE55KRRB ⁽¹⁾		

NOTE: Shaft diameter with an S = Smaller housing.
⁽¹⁾ Shaft Guard Technology available
⁽²⁾ Inner Ring with SGT is wider by 0.737mm [0.029 in.]
⁽³⁾ Inner Ring with SGT is wider by 1.016mm [0.040 in.]
⁽⁴⁾ Inner Ring with SGT is wider by 2.540mm [0.100 in.]
⁽⁵⁾ Inner Ring with SGT is wider by 1.143mm [0.045 in.]

SCJT STANDARD SERIES

- This series has the same construction and design as SCJ type, but is mounted with two bolts instead of four.
- This series is assembled with GYA-RRB bearings with positive-contact, land-riding seals and set screw locking.
- The units are factory-prelubricated. A grease fitting is provided for relubrication.

Suggested shaft tolerances:

- 1/2 in. – 1 15/16 in., nominal to -0.013 mm, -0.0005 in.;
- 2 in. – 2 3/16 in., nominal to -0.025 mm, -0.0010 in.

To order, specify UNIT and SHAFT DIAMETER.

Example: SCJT 1 in.

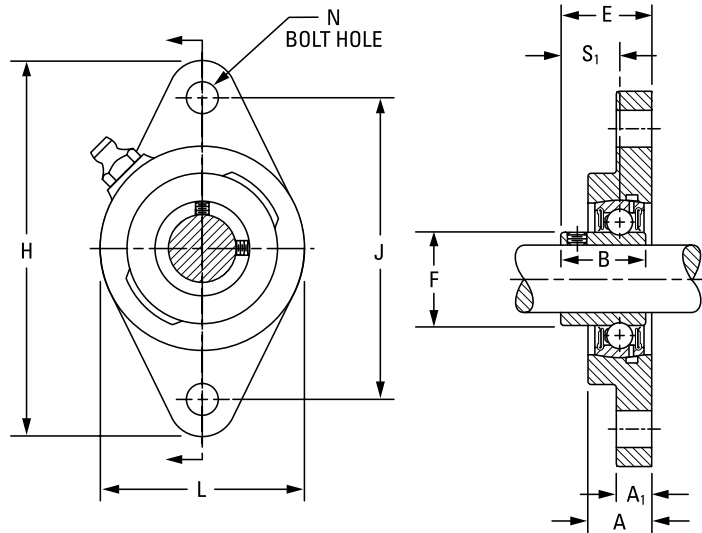

BEARING DATA

Unit	Bearing No.	Dimensions and Load Ratings
SCJT	GYA-RRB	Page 56

Unit	Shaft Dia.	Dimensions										Bolt Size	Bearing No.	Housing No. New (Old)	Unit Wt. kg lbs.	
		H	J	L	A	E	N	B	A ₁	F	S ₁					
	in. mm	mm in.	mm in.	mm in.	mm in.	mm in.	mm in.	mm in.	mm in.	mm in.	mm in.	mm in.				
SCJT	1/2	98.4	76.20	60.3	17.9	25.4	9.9	23.8	11.1	24.6	15.9	10	GYA008RRB		0.34	
SCJT	5/8	3 7/8	3	2 3/8	45/64	1	25/64	15/16	7/16	31/32	5/8	3/8	GYA010RRB	Z955313 (T40136)	0.75	
SCJT	17												GYAE17RRB			
SCJT	3/4	111.9	89.69	65.1	19.0	28.6	9.9	27.0	11.1	29.0	18.3	10	GYA012RRB	Z955330 (T40138)	0.43	
SCJT	20	4 13/32	3 17/32	2 9/16	3/4	1 1/8	25/64	1 1/16	7/16	1 9/64	23/32	3/8	GYAE20RRB		0.94	
SCJT	7/8												GYA014RRB			
SCJT	15/16	123.8	98.82	69.9	19.8	29.8	11.9	28.2	11.1	33.7	19.4	10	GYA015RRB	Z955312 (T40140)	0.48	
SCJT	1	4 7/8	3 57/64	2 3/4	25/32	1 11/64	15/32	1 7/64	7/16	1 21/64	49/64	3/8	GYA100RRB		1.07	
SCJT	25												GYAE25RRB			
SCJT	1 1/8												GYA102RRB			
SCJT	1 3/16	141.3	116.68	79.4	21.4	34.1	11.5	32.5	13.5	40.1	23.0	10	GYA103RRB	Z955328 (T40142)	0.72	
SCJT	1 1/4 S	5 9/16	4 19/32	3 1/8	27/32	1 11/32	29/64	1 9/32	17/32	1 37/64	29/32	3/8	GYA103RRB3		1.58	
SCJT	30												GYAE30RRB			
SCJT	1 1/4												GYA104RRB			
SCJT	1 3/8	155.6	130.18	92.1	24.6	38.1	13.1	36.5	14.3	46.8	25.8	12	GYA106RRB	Z955322 (T40144)	1.08	
SCJT	1 7/16	6 1/8	5 1/8	3 5/8	31/32	1 1/2	33/64	1 7/16	9/16	1 27/32	1 1/64	1/2	GYA107RRB		2.37	
SCJT	35												GYAE35RRB			
SCJT	1 1/2	171.5	143.67	104.8	26.2	40.9	13.1	39.3	14.3	52.4	27.8	12	GYA108RRB	Z955351 (T40146)	1.97	
SCJT	40	6 3/4	5 21/32	4 1/8	1 1/32	1 39/64	33/64	1 35/64	9/16	2 1/16	1 3/32	1/2	GYAE40RRB		4.34	
SCJT	1 5/8												GYA110RRB			
SCJT	1 11/16	179.4	148.00	111.1	28.6	43.6	13.1	42.1	15.8	57.9	28.6	12	GYA111RRB	Z956486 (T40170)	2.03	
SCJT	1 3/4	7 1/16	5 27/32	4 3/8	1 1/8	1 23/32	33/64	1 21/32	5/8	2 5/32	1 7/8	1/2	GYA112RRB		4.48	
SCJT	45												GYAE45RRB			
SCJT	1 15/16												GYA115RRB			
SCJT	2 S	189.9	157.16	115.8	28.6	46.0	17.1	44.4	16.6	62.7	30.9	16	GYA115RRB2	Z956393 (T40172)	2.26	
SCJT	50	7 7/16	6 3/16	4 9/16	1 1/8	1 13/16	43/64	1 3/4	21/32	2 15/32	1 7/32	5/8	GYAE50RRB		4.98	
SCJT	2												GYA200RRB			
SCJT	2 3/16	215.9	184.15	127.0	30.9	48.0	17.1	46.4	18.2	69.8	31.7	16	GYA203RRB	Z956404 (T40174)	2.79	
SCJT	55	8 1/2	7 1/4	5	1 1/32	1 57/64	43/64	1 53/64	23/32	2 3/4	1 1/4	5/8	GYAE55RRB		6.14	

NOTE: Shaft diameter with an S = smaller housing.

FLCT STANDARD SERIES

- These versatile power-transmission units are designed to provide sturdy shaft support in minimum space at minimum cost.
- The space-saving, two-bolt unit mounts flush against the frame.
- The bolt-hole spacing and size is the same as the pressed-steel flangette unit.
- The series is equipped with RA-RRB extended inner ring ball bearings with positive-contact, land-riding seals.
- The series is permanently prelubricated.

Suggested shaft tolerances:

1/2 in. – 1 7/16 in., nominal to -0.013 mm, -0.0005 in.;

To order, specify UNIT and SHAFT DIAMETER.

Example: FLCT 1 3/16 in.

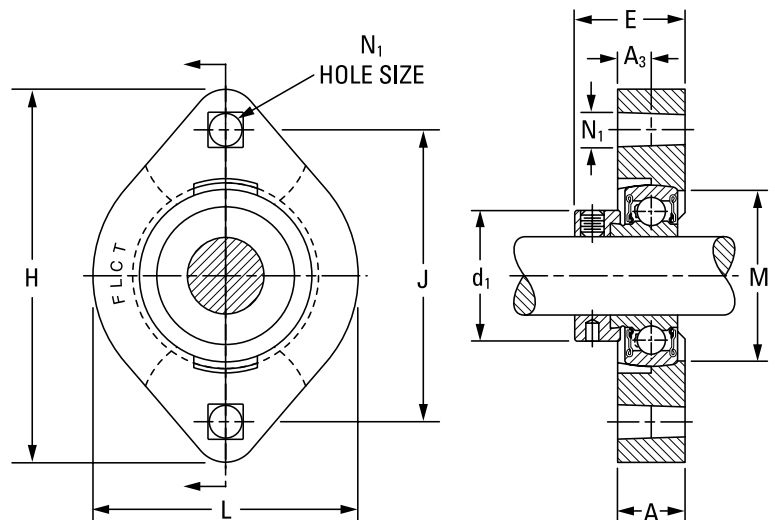

BEARING DATA

Unit	Bearing No.	Dimensions and Load Ratings
FLCT	RA-RRB	Page 50

Unit	Shaft Dia.	H	J	L	E	A	A ₃	N ₁ Sq.	d ₁	M	Bolt Size	Bearing No.	Collar No.	Housing No. New (Old)	Unit Wt. kg lbs.
	in. mm	mm in.	mm in.	mm in.	mm in.	mm in.	mm in.	mm in.	mm in.	mm in.	mm in.				
FLCT	1/2	81.0	63.5	58.7	30.2	14.7	7.1	7.1	28.6	38.1	6	RA008RRB	S1008K		0.322
FLCT	5/8	3 3/16	2 1/2	2 5/16	1 3/16	37/64	9/32	9/32	1 1/8	1 1/2	1/4	RA010RRB	S1010K	Z956420 (T24080P)	0.71
FLCT	17											RAE17RRB	SE17K		
FLCT	3/4	90.5	71.4	66.7	32.9	17.1	8.7	8.7	33.3	45.2	8	RA012RRB	S1012K	Z956391 (T24093P)	0.445
FLCT	20	3 3/16	2 13/16	2 5/8	1 19/64	43/64	1 1/32	1 1/32	1 5/16	1 25/32	5/16	RAE20RRB	SE20K		0.98
FLCT	7/8											RA014RRB	S1014K		
FLCT	15/16	95.2	76.2	71.0	34.5	17.5	8.7	8.7	38.1	50.4	8	RA015RRB	S1015K	Z956379 (T23961P)	0.499
FLCT	1	3 3/4	3	2 51/64	1 23/64	1 1/16	1 1/32	1 1/32	1 1/2	1 63/64	5/16	RA100RRB	S1100K		1.10
FLCT	25											RAE25RRB	SE25K		
FLCT	1 1/8											RA102RRB	S1102K		
FLCT	1 3/16	112.7	90.5	84.1	38.5	20.6	10.3	10.3	44.4	59.5	10	RA103RRB	S1103K	Z956386 (T24018P)	0.835
FLCT	1 1/4 S	4 7/16	3 9/16	3 5/16	1 33/64	13/16	13/32	13/32	1 3/4	2 11/32	3/8	RA103RRB2	S1103K3		1.84
FLCT	30											RAE30RRB	SE30K		
FLCT	1 1/4											RA104RRB	S1104K		
FLCT	1 3/8	125.4	100.0	93.7	41.1	22.2	11.1	10.3	54.0	69.5	10	RA106RRB	S1106K	Z956381 (T24068P)	1.075
FLCT	1 7/16	4 15/16	3 15/16	3 11/16	1 21/32	7/8	7/16	13/32	2 1/8	2 47/64	3/8	RA107RRB	S1107K		2.37
FLCT	35											RAE35RRB	SE35K		

NOTE: Shaft diameter with an S = smaller housing.

RFC INDUSTRIAL PILOTED-SERIES CONCENTRIC COLLAR

- The piloted flange cartridges ensure accurate mounting fits and provide better support for heavy loads.
- The cast-iron units are suited for applications such as material handling, industrial conveyor equipment, and farm and construction equipment.
- This series is assembled with R-seal (GC-KRRB) bearings with a concentric-locking collar.
- The units are factory-prelubricated. A grease fitting is provided for relubrication if required.

Suggested shaft tolerances:

- 1/2 in. – 1 15/16 in., nominal to -0.013 mm, -0.0005 in.;
- 2 in. – 2 3/16 in., nominal to -0.025 mm, -0.0010 in.

To order, specify UNIT and SHAFT DIAMETER.

Example: RFC 1 7/16 in.

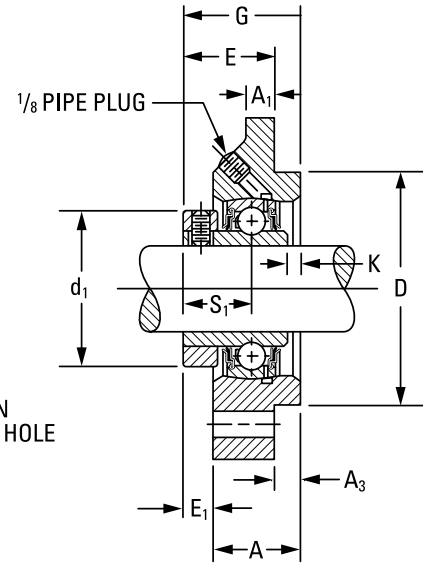
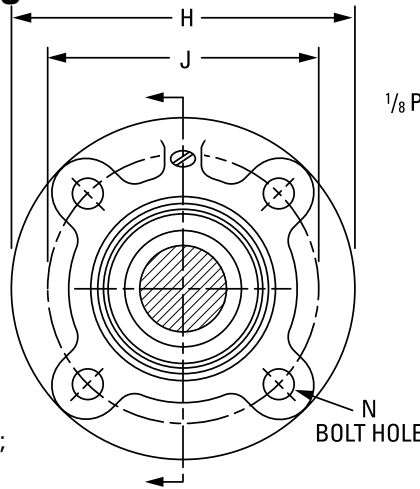

BEARING DATA

Unit	Bearing No.	Dimensions and Load Ratings
RFC	GC-KRRB	Page 42

Unit	Shaft Dia.	Dimensions														Bolt Size	Bearing No.	Collar No.	Housing No. New (Old)	Unit Wt.			
		D	J	H	S ₁	K	N	G	A	E ₁	A ₃	E	A ₁	d ₁	mm in.						mm in.	mm in.	mm in.
RFC	7/8	76.20	92.1	111.1	20.2	3.6	10.3	37.7	28.2	9.5	6.4	31.4	9.5	44.4	10	GC1014KRRB	C205	Z955340 (T27031)	1.152				
RFC	15/16	3.000	3 5/8	4 3/8	5/64	9/64	13/32	1 31/64	1 7/64	3/8	1/4	1 15/64	3/8	1 3/4	3/8	GC1015KRRB			2.54				
RFC	1															GC1100KRRB							
RFC	1 1/8	85.72	104.8	127.0	22.6	3.6	11.9	40.9	30.6	10.3	10.7	30.2	9.5	52.4	10	GC1102KRRB	C206	Z956527 (T27029)	1.742				
RFC	1 3/16	3.375	4 1/8	5	57/64	9/64	15/32	1 39/64	1 13/64	13/32	27/64	1 3/16	3/8	2 1/16	3/8	GC1103KRRB			3.84				
RFC	1 1/4 S															GC1103KRRB3							
RFC	1 1/4	92.08	111.1	133.4	25.4	3.2	11.9	44.4	34.1	10.3	11.9	32.5	12.7	59.5	10	GC1104KRRB	C207	Z955308 (T26730)	1.864				
RFC	1 3/8	3.625	4 3/8	5 1/4	1	1/8	15/32	1 3/4	1 11/32	13/32	15/32	1 9/32	1/2	2 11/32	3/8	GC1106KRRB			4.11				
RFC	1 7/16															GC1107KRRB							
RFC	1 1/2	92.08	111.1	133.4	27.4	4.8	11.9	48.8	38.1	10.7	11.9	36.9	12.7	68.3	10	GC1108KRRB	C208	Z956417 (T26587)	2.141				
RFC	1 1/2	3.625	4 3/8	5 1/4	1 5/64	3/16	15/32	1 59/64	1 1/2	27/64	15/32	1 29/64	1/2	2 11/16	3/8				4.72				
RFC	1 5/8																						
RFC	1 5/8	107.95	130.2	155.6	29.4		13.5	46.8	34.1	12.7	11.9	34.9	11.5	73.0	12	GC1110KRRB	C209	Z956490 (T27276)	2.817				
RFC	1 11/16	4.250	5 1/8	6 1/8	1 5/32	-	17/32	1 27/32	1 11/32	1/2	15/32	1 3/8	29/64	2 7/8	1 1/2	GC1111KRRB			6.21				
RFC	1 3/4															GC1112KRRB							
RFC	1 15/16	114.30	136.5	161.9	30.2	6.4	13.5	54.8	42.9	11.9	15.9	38.9	12.7	79.4	12	GC1115KRRB	C210	Z956492 (T26743)	3.211				
RFC	1 15/16	4.500	5 3/8	6 3/8	1 3/16	1/4	17/32	2 5/32	1 11/16	15/32	5/8	1 17/32	1/2	3 1/8	1 1/2				7.08				
RFC	2																						
RFC	2	127.00	152.4	181.0	33.3	7.1	15.1	61.1	44.4	16.7	22.2	38.9	12.7	88.9	12	GC1200KRRB	C211	Z956497 (T28287)	4.082				
RFC	2 3/16	5.000	6	7 1/8	1 5/16	9/32	19/32	2 13/32	1 3/4	2 1/32	7/8	1 17/32	1/2	3 1/2	1 1/2	GC1203KRRB			9.00				

NOTE: Shaft diameter with an S = smaller housing.

RC SERIES

- The RC series is convenient for mounting in straight-bore housings.
- The bearing features a self-locking collar and spherical outside diameter fitted to a corresponding spherical seat in the cartridge that provides self-alignment.
- The unit is equipped with a G-KRRB (R-seal) bearing.

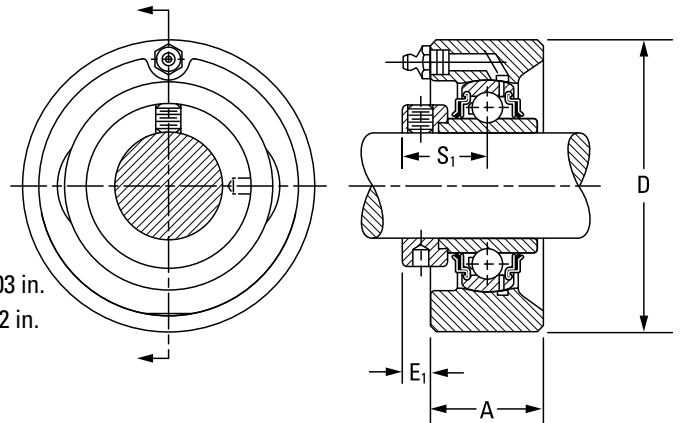

Suggested housing bore:

Shaft Rotating: nominal +.025 mm to +.076 mm, +.001 in. to +.003 in.
 Shaft Stationary: nominal +.00 mm to -.050 mm, +.000 in. to -.002 in.
 Avoid excessive tightening of anchor bolts.

Suggested shaft tolerances:

1/2 in. – 1 15/16 in., nominal to -0.013 mm, -0.0005 in.;
 2 in. – 2 7/16 in., nominal to -0.025 mm, -0.0010 in.

To order, specify UNIT and SHAFT DIAMETER.

Example: RC 1 3/16 in.

BEARING DATA

Unit	Bearing No.	Dimensions and Load Ratings
RC	G-KRRB	Page 36

Unit ⁽¹⁾	Shaft Dia.	Dimensions				Bearing No.	Collar No.	Housing No. New (Old)	Unit Wt.
		D	A	E ₁	S ₁				
	in. mm	mm in.	mm in.	mm in.	mm in.				kg lbs.
RC	1/2					G1008KRRB	S1008K		
RC	5/8	68.27	30.2	8.3	23.4	G1010KRRB	S1010K	T16793	0.549 1.21
RC	11/16	2 11/16	1 3/16	2 1/64	59/64	G1011KRRB	S1011K		
RC	17					GE17KRRB	SE17K		
RC	3/4	74.61	36.5	8.3	26.6	G1012KRRB	S1012K	Z956668 (T16795)	0.804 1.77
RC	20	2 15/16	1 7/16	2 1/64	1 3/64	GE20KRRB	SE20K		
RC	7/8					G1014KRRB	S1014K	Z956540 (T16797)	0.876 1.93
RC	15/16	79.38	38.1	7.9	27.0	G1015KRRB	S1015K		
RC	1	3 1/8	1 1/2	5/16	1 1/16	G1100KRRB	S1100K		
RC	25					GE25KRRB	SE25K		
RC	1 1/16					G1101KRRB	S1101K		
RC	1 1/8	88.90	38.1	11.1	30.2	G1102KRRB	S1102K	Z956510 (T16798)	1.171 2.58
RC	1 3/16	3 1/2	1 1/2	7/16	1 3/16	G1103KRRB	S1103K		
RC	30					GE30KRRB	SE30K		
RC	1 1/4					G1104KRRB	S1104K		
RC	1 5/16					G1105KRRB	S1105K	Z956473 (T16686)	1.448 3.19
RC	1 3/8	98.43	39.7	12.7	32.5	G1106KRRB	S1106K		
RC	1 7/16	3 7/8	1 9/16	1/2	1 9/32	G1107KRRB	S1107K		
RC	35					GE35KRRB	SE35K		
RC	1 1/2					G1108KRRB	S1108KT	Z956536 (T16800)	1.870 4.12
RC	1 9/16	106.36	44.4	12.7	34.9	G1109KRRB	S1109KT		
RC	40	4 3/16	1 3/4	1/2	1 3/8	GE40KRRB	SE40K		
RC	1 5/8					G1110KRRB	S1110K	Z956419 (T16687)	1.970 4.34
RC	1 11/16	111.13	44.4	12.7	34.9	G1111KRRB	S1111K		
RC	1 3/4	4 3/8	1 3/4	1/2	1 3/8	G1112KRRB	S1112K		
RC	45					GE45KRRB	SE45K		
RC	1 7/8					G1114KRRB	S1114K	Z956488 (T16802)	2.452 5.40
RC	1 15/16	115.89	52.4	11.9	38.1	G1115KRRB	S1115K		
RC	50	4 9/16	2 1/16	15/32	1 1/2	GE50KRRB	SE50K		
RC	2					G1200KRRB	S1200K	Z956475 (T16804)	3.164 6.97
RC	2 1/8	125.41	58.7	14.3	43.7	G1202KRRB	S1202K		
RC	2 3/16	4 15/16	2 5/16	9/16	1 23/32	G1203KRRB	S1203K		
RC	55					GE55KRRB	SE55K		
RC	2 7/16	149.23	65.1	14.3	46.8	G1207KRRB	S1207K		
RC	60	5 7/8	2 9/16	9/16	1 27/32	GE60KRRB	SE60K	Z956563 (T17927)	5.130 11.30

⁽¹⁾All units have 1/4-28 grease fittings.

MOUNTED BALL BEARINGS

MALLEABLE-IRON FLANGED UNITS • GVFD, GVFDR, VFD, VRDR

MALLEABLE-IRON FLANGED UNITS

GVFD, GVFDR RELUBRICATABLE SERIES – VFD, VFDR NON-RELUBRICATABLE SERIES

- The malleable-iron flange cartridges provide self-alignment and rigid support for medium-duty applications.
- The mounting bolt holes are interchangeable with pressed-steel flange units of corresponding size.

Suggested shaft tolerances: nominal to -0.013 mm, -0.0005 in.

To order, specify UNIT and SHAFT DIAMETER.

For the non-relubricatable series, omit the G prefix on the unit and bearing number.

Example: VFD 1 3/16 in. or VFDR 1 3/16 in.; GVFD 1 3/16 in. or GVFDR 1 3/16 in.

BEARING DATA

Unit	Bearing No.	Dimensions and Load Ratings
VFD, VFDR	RA-RRB	Page 50
GVFD, GVFDR	GRA-RRB	Page 52

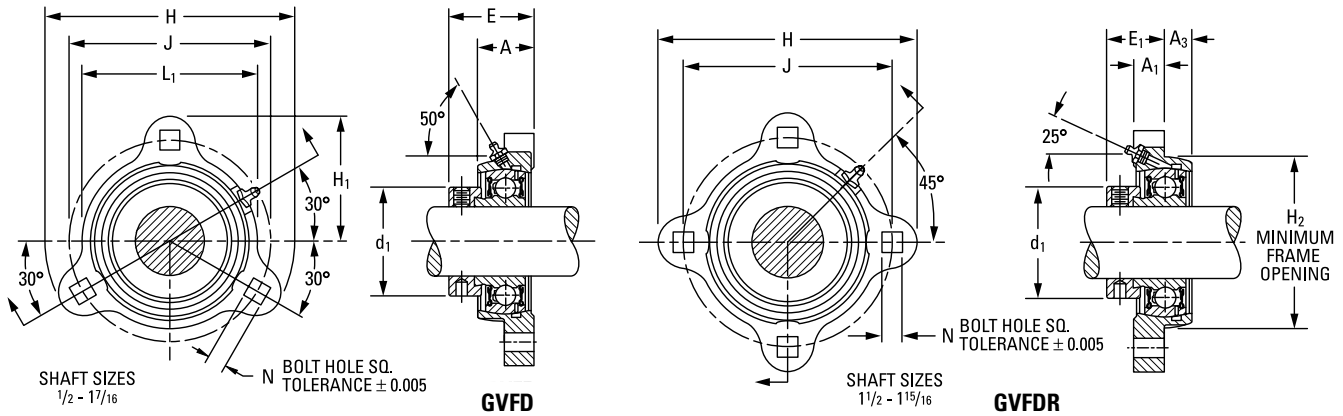

Unit	Shaft Dia.	Dimensions													Bearing No.	Housing No. New (Old)	Collar No.	Unit Wt.		
		H ₁	L ₁	H	J	N	H ₂	E	A	E ₁	A ₃	A ₁	d ₁	kg					lbs.	
Face Mounted	Reverse Mounted	in.	mm	mm	mm	mm	mm	mm	mm	mm	mm	mm	mm	mm	mm	mm				
RELUBRICATABLE SERIES⁽¹⁾																				
GVFD ⁽²⁾	GVFDR ⁽²⁾	1/2	40.5	53.2	81.0	63.5	7.1	47.6	31.8	17.5	22.2	7.9	9.5	28.6	GRA008RRB	-	S1008K	2.63		
GVFD ⁽²⁾	GVFDR ⁽²⁾	5/8	1 19/32	2 3/32	3 3/16	2 1/2	9/32	1 7/8	1 1/4	1 1/16	7/8	5/16	3/8	1 1/8	GRA010RRB	-	S1010K	0.58		
GVFD ⁽²⁾	GVFDR ⁽²⁾	17													GRAE17RRB	-	SE17K			
GVFD ⁽²⁾	GVFDR	3/4	45.2	60.3	90.5	71.4	8.7	54.8	34.1	19.8	23.4	9.1	10.7	33.3	GRA012RRB	-	S1012K	0.336		
GVFD ⁽²⁾	GVFDR	20	1 25/32	2 3/8	3 9/16	2 13/16	1 1/32	2 5/32	1 11/32	2 5/32	59/64	23/64	27/64	1 5/16	GRAE20RRB	-	SE20K	0.74		
GVFD	GVFDR	7/8													GRA014RRB	-	S1014K			
GVFD	GVFDR	15/16	47.6	66.7	95.2	76.2	8.7	60.3	34.1	19.8	23.4	9.1	10.7	38.1	GRA015RRB	Z956407	S1015K	0.386		
GVFD	GVFDR	1	1 7/8	2 5/8	3 3/4	3	1 1/32	2 3/8	1 11/32	2 5/32	59/64	23/64	27/64	1 1/2	GRA100RRB	(T33335)	S1100K	0.85		
GVFD	GVFDR	25													GRAE25RRB	-	SE25K			
GVFD	GVFDR	1 1/8													GRA102RRB	-	S1102K			
GVFD	GVFDR	1 3/16	56.4	78.6	112.7	90.5	10.3	71.4	38.9	22.2	26.6	10.7	11.9	44.5	GRA103RRB	Z956409	S1103K	0.608		
GVFD	GVFDR	1 1/4 S	2 7/32	3 3/32	4 7/16	3 9/16	1 3/32	2 13/16	1 17/32	7/8	1 3/64	27/64	15/32	1 3/4	GRA103RRB2	(T31932)	S1103K3	1.34		
GVFD	GVFDR	30													GRAE30RRB	-	SE30K			
GVFD	GVFDR	1 1/4													GRA104RRB	-	S1104K			
GVFD	GVFDR	1 3/8	61.1	88.9	122.2	100.0	10.3	81.8	42.1	23.8	29.4	11.1	12.7	54.0	GRA106RRB	Z956474	S1106K	0.821		
GVFD	GVFDR	1 7/16	2 13/32	3 1/2	4 13/16	3 15/16	1 3/32	3 7/32	1 21/32	1 5/16	1 9/32	7/16	1/2	2 1/8	GRA107RRB	(T32432)	S1107	1.81		
GVFD	GVFDR	35													GRAE35RRB	-	SE35K			
GVFD	GVFDR	1 1/2	73.8	98.4	147.6	119.1	13.5	89.7	48.4	28.6	32.5	12.7	15.9	60.3	GRA108RRB	Z956380	S1108KT	1.334		
GVFD	GVFDR	40	2 29/32	3 7/8	5 13/16	4 11/16	1 7/32	3 17/32	1 29/32	1 1/8	1 9/32	1/2	5/8	2 3/8	GRAE40RRB	(T26781)	SE40K	2.94		
GVFD	GVFDR	1 5/8													GRA110RRB	-	S1110K			
GVFD	GVFDR	1 11/16	74.6	107.2	149.2	120.6	13.5	96.0	48.4	28.6	32.5	12.7	15.9	63.5	GRA111RRB	Z956487	S1111K	1.361		
GVFD	GVFDR	1 3/4	2 15/16	4 7/32	5 7/8	4 3/4	1 7/32	3 25/32	1 29/32	1 1/8	1 9/32	1/2	5/8	2 1/2	GRA112RRB	(T26803)	S1112K	3.00		
GVFD	GVFDR	45													GRAE45RRB	-	SE45K			
GVFD	GVFDR	1 7/8													GRA114RRB	-	S1114K			
GVFD	GVFDR	1 15/16	77.8	113.5	155.6	127.0	13.5	100.8	48.4	28.6	32.5	12.7	15.9	69.8	GRA115RRB	Z956543	S1115K	1.451		
GVFD	GVFDR	50	3 1/16	4 15/32	6 1/8	5	1 7/32	3 31/32	1 29/32	1 1/8	1 9/32	1/2	5/8	2 3/4	GRAE50RRB	(T26836)	SE50K	3.20		

⁽¹⁾All units have a 1/4-28 grease fitting, except as noted.

⁽²⁾10-32 grease fitting.

NOTE: Shaft diameter with an S = smaller housing.

GRFD, GRFDR RELUBRICATABLE SERIES – RFD, RFDR NON-RELUBRICATABLE SERIES

- The malleable-iron flange cartridges provide self-alignment and rigid support for medium-duty applications.

Suggested shaft tolerances: nominal to -0.013 mm, -0.0005 in.

To order, specify UNIT and SHAFT DIAMETER.

For the non-relubricatable series, omit G prefix on unit and bearing number.

Example: GRFD 1 3/16 in. or GRFDR 1 3/16 in.; RFD 1 3/16 in. or RFDR 1 3/16 in.

BEARING DATA

Unit	Bearing No.	Dimensions and Load Ratings
RFD, RFDR	-KRRB	Page 34
GRFD, GRFDR	G-KRRB	Page 36

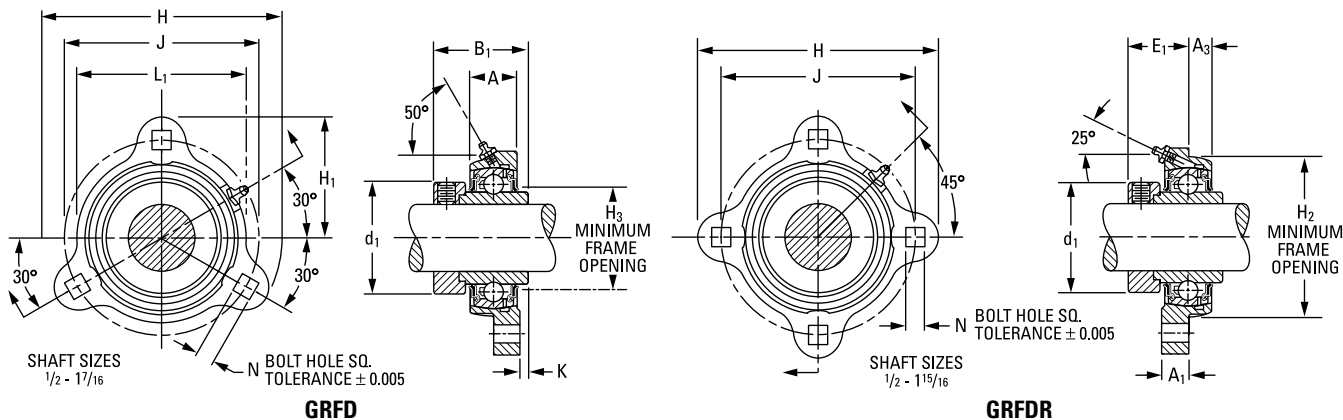

Unit		Shaft Dia.	RELUBRICATABLE SERIES ⁽¹⁾													Bearing No.	Housing No. New (Old)	Collar No.	Unit Wt.	
Face Mounted	Reverse Mounted	in. mm	H ₁ mm in.	L ₁ mm in.	H mm in.	J mm in.	N mm in.	H ₂ mm in.	B ₁ mm in.	A mm in.	E ₁ mm in.	A ₃ mm in.	A ₁ mm in.	d ₁ mm in.	H ₃ mm in.	K mm in.			kg lbs.	
GRFD ⁽²⁾	GRFDR ⁽²⁾	1/2															G1008KRRB		S1008K	
GRFD ⁽²⁾	GRFDR ⁽²⁾	5/8	40.5	53.2	81.0	63.5	7.1	47.6	37.3	17.5	23.4	7.9	9.5	28.6	29.4	4.4	G1010KRRB		S1010K	0.259
GRFD ⁽²⁾	GRFDR ⁽²⁾	11/16	1 19/32	2 3/32	3 3/16	2 1/2	9/32	1 7/8	1 15/32	1 1/16	59/64	5/16	3/8	1 1/8	1 1/32	1 1/64	G1011KRRB		S1011K	0.57
GRFD ⁽²⁾	GRFDR ⁽²⁾	17															GE17KRRB		SE17K	
GRFD ⁽²⁾	GRFDR	3/4	45.2	60.3	90.5	71.4	8.7	54.8	43.7	19.8	26.6	9.1	10.7	33.3	34.1	6.4	G1012KRRB		S1012K	0.395
GRFD ⁽²⁾	GRFDR	20	1 25/32	2 3/8	3 9/16	2 13/16	1 1/32	2 5/32	1 23/32	25/32	1 3/64	23/64	27/64	1 5/16	1 11/32	1/4	GE20KRRB		SE20K	0.87
GRFD	GRFDR	7/8															G1014KRRB		S1014K	
GRFD	GRFDR	15/16	47.6	66.7	95.2	76.2	8.7	60.3	44.4	19.8	27.0	9.1	10.7	38.1	38.9	6.7	G1015KRRB	Z956407	S1015K	0.463
GRFD	GRFDR	1	1 7/8	2 5/8	3 3/4	3	1 1/32	2 3/8	1 3/4	25/32	1 1/16	23/64	27/64	1 1/2	1 17/32	17/64	G1100KRRB	(T33335)	S1100K	1.02
GRFD	GRFDR	25															GE25KRRB		SE25K	
GRFD	GRFDR	1 1/16															G1101KRRB		S1101K	
GRFD	GRFDR	1 1/8	56.4	78.6	112.7	90.5	10.3	71.4	48.4	22.2	30.2	10.7	11.9	44.5	46.0	6.4	G1102KRRB	Z956409	S1102K	6.260
GRFD	GRFDR	1 3/16	2 7/32	3 3/32	4 7/16	3 9/16	13/32	2 13/16	1 29/32	7/8	1 3/16	27/64	15/32	1 3/4	1 13/16	1/4	G1103KRRB	(T31932)	S1103K	1.38
GRFD	GRFDR	1 1/4 S															G1103KRRB3		S1103K3	
GRFD	GRFDR	30															GE30KRRB		SE30K	
GRFD	GRFDR	1 1/4															G1104KRRB		S1104K	
GRFD	GRFDR	1 5/16	61.1	88.9	122.2	100.0	10.3	81.8	51.2	23.8	32.5	11.1	12.7	54.0	53.2	6.4	G1105KRRB	Z956474	S1105K	0.857
GRFD	GRFDR	1 3/8	2 13/32	3 1/2	4 13/16	3 15/16	13/32	3 7/32	2 1/64	15/16	1 9/32	7/16	1/2	2 1/8	2 3/32	1/4	G1106KRRB	(T32432)	S1106K	1.89
GRFD	GRFDR	1 7/16															G1107KRRB		S1107K	
GRFD	GRFDR	35															GE35KRRB		SE35K	
GRFD	GRFDR	1 1/2	73.8	98.4	147.6	119.1	13.5	89.7	56.4	28.6	34.9	12.7	15.9	60.3	59.5	5.6	G1108KRRB	Z956380	S1108KT	1.138
GRFD	GRFDR	1 9/16	2 29/32	3 7/8	5 13/16	4 11/16	17/32	3 17/32	2 7/32	1 1/8	1 3/8	1/2	5/8	2 3/8	2 11/32	7/32	G1109KRRB	(T26781)	S1109KT	2.50
GRFD	GRFDR	40															GE40KRRB		SE40K	
GRFD	GRFDR	1 5/8															G1110KRRB		S1110K	
GRFD	GRFDR	1 11/16	74.6	107.2	149.2	120.6	13.5	96.0	56.4	28.6	34.9	12.7	15.9	63.5	65.1	5.6	G1111KRRB		S1111K	1.488
GRFD	GRFDR	1 3/4	2 15/16	4 7/32	5 7/8	4 3/4	17/32	3 25/32	2 7/32	1 1/8	1 3/8	1/2	5/8	2 1/2	2 9/16	7/32	G1112KRRB		S1112K	3.28
GRFD	GRFDR	45															GE45KRRB		SE45K	
GRFD	GRFDR	1 7/8	77.8	113.5	155.6	127.0	13.5	100.8	62.7	28.6	38.1	12.7	15.9	69.8	69.8	8.7	G1114KRRB	Z956543	S1114K	1.692
GRFD	GRFDR	1 15/16	3 1/16	4 15/32	6 1/8	5	17/32	3 31/32	2 15/32	1 1/8	1 1/2	1/2	5/8	2 3/4	2 3/4	11/32	G1115KRRB	(T26836)	S1115K	3.73
GRFD	GRFDR	50															GE50KRRB		SE50K	

⁽¹⁾All units have a 1/4-28 grease fitting, except as noted.

⁽²⁾10-32 grease fitting.

NOTE: Shaft diameter with an S = smaller housing.

MOUNTED BALL BEARINGS

MALLEABLE-IRON FLANGED UNITS • GVFTD, GVFTDR, VFTD, VFTDR

GVFTD, GVFTDR RELUBRICATABLE SERIES – VFTD, VFTDR NON-RELUBRICATABLE SERIES

- The malleable-iron flange cartridges provide self-alignment and rigid support for medium-duty applications.

Suggested shaft tolerances: nominal to -0.013 mm, -0.0005 in.

To order, specify UNIT and SHAFT DIAMETER.

For the non-relubricatable series, omit G prefix on unit and bearing number.

Example: VFTD 1 3/16 in. or VFTDR 1 3/16 in.; GVFTD 1 3/16 in. or GVFTDR 1 3/16 in.

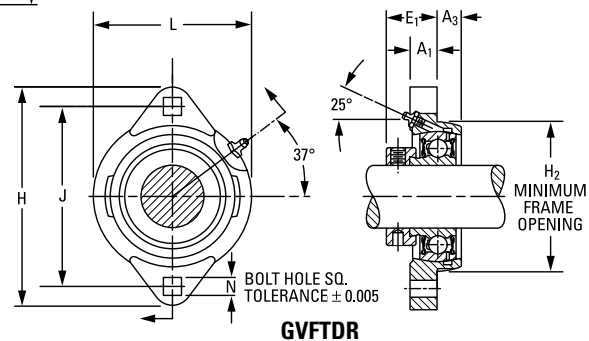
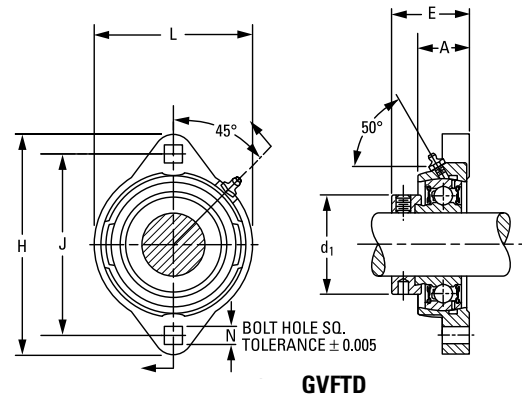
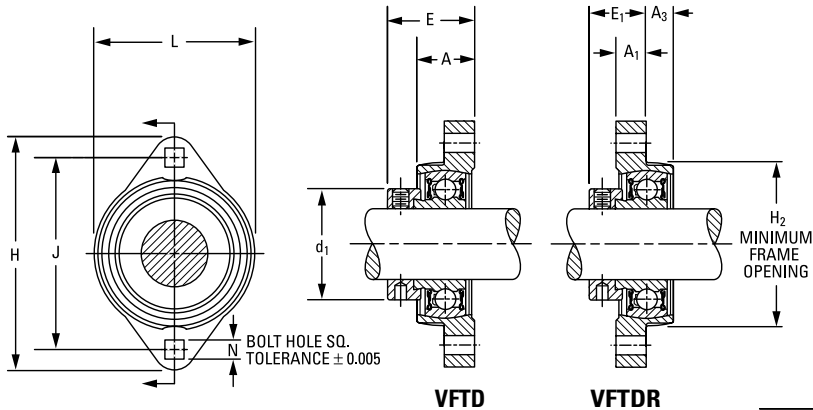

BEARING DATA

Unit	Bearing No.	Dimensions and Load Ratings
VFTD, VFTDR	RA-RRB	Page 50
GVFTD, GVFTDR	GRA-RRB	Page 52

Unit		Shaft Dia.	Dimensions and Load Ratings											Bearing No.	Housing No. New (Old)	Collar No.	Unit Wt.
Face Mounted	Reverse Mounted		H	J	L	N	H ₂	E	A	E ₁	A ₃	A ₁	d ₁				
RELUBRICATABLE SERIES⁽¹⁾																	
GVFTD	GVFTDR	1/2	81.0	63.5	53.2	7.1	47.6	31.8	17.5	22.2	7.9	9.5	28.6	GRA008RRB	Z956415	S1008K	0.245
GVFTD	GVFTDR	5/8	3 3/16	2 1/2	2 3/32	9/32	1 7/8	1 1/4	11/16	7/8	5/16	3/8	1 1/8	GRA010RRB	(T26787)	S1010K	0.54
GVFTD	GVFTDR	17												GRAE17RRB		SE17K	
GVFTD	GVFTDR	3/4	90.5	71.4	60.3	8.7	54.8	34.1	19.8	23.4	9.1	10.7	33.3	GRA012RRB	Z956415	S1012K	0.331
GVFTD	GVFTDR	20	3 9/16	2 13/16	2 3/8	1 1/32	2 5/32	1 11/32	25/32	59/64	23/64	27/64	1 5/16	GRAE20RRB	(T26787)	SE20K	0.73
GVFTD	GVFTDR	7/8												GRA014RRB		S1014K	
GVFTD	GVFTDR	15/16	95.2	76.2	66.7	8.7	60.3	34.1	19.8	23.4	9.1	10.7	38.1	GRA015RRB	Z956385	S1015K	0.363
GVFTD	GVFTDR	1	3 3/4	3	2 5/8	1 1/32	2 3/8	1 11/32	25/32	59/64	23/64	27/64	1 1/2	GRA100RRB	(T32544)	S1100K	0.80
GVFTD	GVFTDR	25												GRAE25RRB		SE25K	
GVFTD	GVFTDR	1 1/8												GRA102RRB		S1102K	
GVFTD	GVFTDR	1 3/16	112.7	90.5	78.6	10.3	71.4	38.9	22.2	26.6	10.7	11.9	44.5	GRA103RRB	Z956382	S1103K	0.608
GVFTD	GVFTDR	1 1/4 S	4 7/16	3 3/16	3 3/32	13/32	2 13/16	1 17/32	7/8	1 3/64	27/64	15/32	1 3/4	GRA103RRB2	(T32984)	S1103K3	1.34
GVFTD	GVFTDR	30												GRAE30RRB		SE30K	
GVFTD	GVFTDR	1 1/4												GRA104RRB		S1104K	
GVFTD	GVFTDR	1 3/8	122.2	100.0	88.9	10.3	81.8	42.1	23.8	29.4	11.1	12.7	54.0	GRA106RRB	Z956396	S1106K	0.862
GVFTD	GVFTDR	1 7/16	4 13/16	3 15/16	3 1/2	13/32	3 7/32	1 21/32	15/16	1 5/32	7/16	1/2	2 1/8	GRA107RRB	(T26799)	S1107K	1.90
GVFTD	GVFTDR	35												GRAE35RRB		SE35K	

⁽¹⁾All units have a 1/4-28 grease fitting.

NOTE: Shaft diameter with an S = smaller housing.

**GRFTD, GRFTDR RELUBRICATABLE SERIES –
RFTD, RFTDR NON-RELUBRICATABLE SERIES**

- The malleable-iron flange cartridges provide self-alignment and rigid support for medium-duty applications.

Suggested shaft tolerances: nominal to -0.013 mm, -0.0005 in.

To order, specify UNIT and SHAFT DIAMETER.

For the non-relubricatable series, omit G prefix on unit and bearing number.

Example: RFTD 1 3/16 in. or RFTDR 1 3/16 in.; GRFTD 1 3/16 in. or GRFTDR 1 3/16 in.

BEARING DATA

Unit	Bearing No.	Dimensions and Load Ratings
RFTD, RFTDR	-KRRB	Page 34
GRFTD, GRFTDR	G-KRRB	Page 36

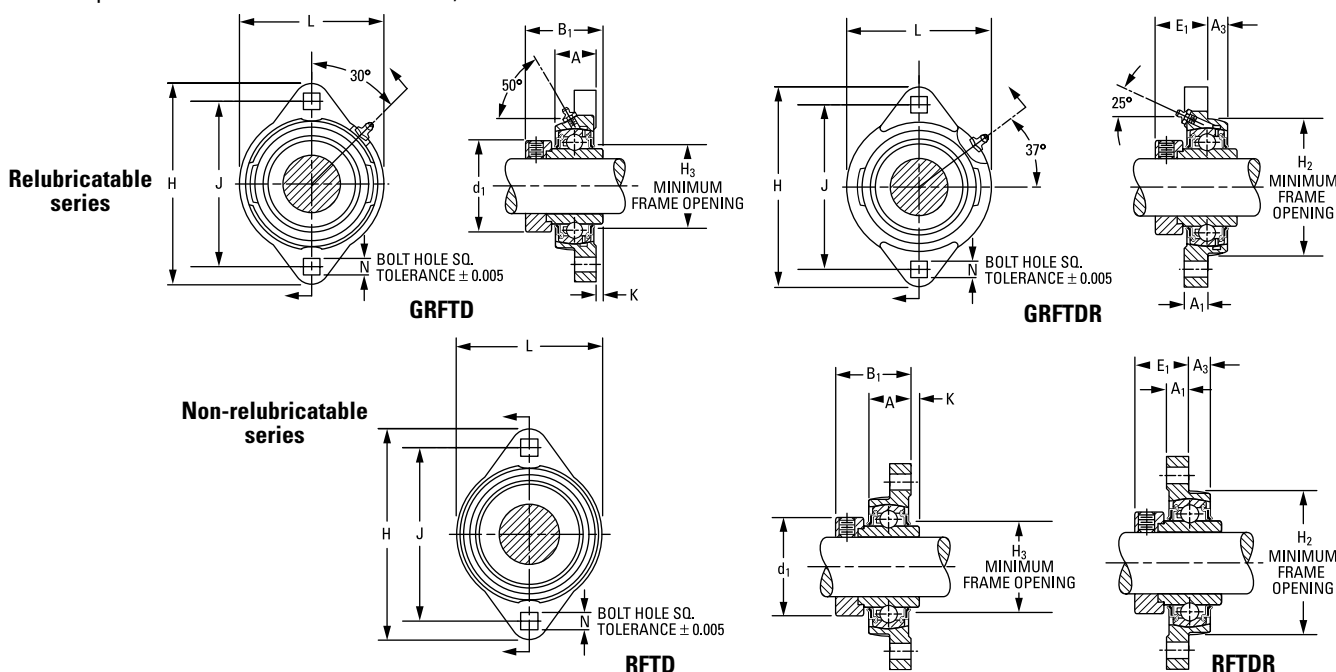

Unit		Shaft Dia.	H	J	L	N	H ₂	B ₁	A	E ₁	A ₃	A ₁	d ₁	H ₃	K	Bearing No.	Housing No. New (Old)	Collar No.	Unit Wt.
Face Mounted	Reverse Mounted	in. mm	mm in.	mm in.	mm in.	mm in.	mm in.	mm in.	mm in.	mm in.	mm in.	mm in.	mm in.	mm in.	mm in.				kg lbs.
RELUBRICATABLE SERIES⁽¹⁾																			
GRFTD	GRFTDR	1/2														G1008KRRB		S1008K	
GRFTD	GRFTDR	5/8	81.0	63.5	53.2	7.1	47.6	37.3	15.9	23.4	7.9	9.5	28.6	29.4	4.4	G1010KRRB	Z956415 (T26787)	S1010K	0.254
GRFTD	GRFTDR	11/16	3 3/16	2 1/2	2 3/32	9/32	1 7/8	1 15/32	5/8	59/64	5/16	3/8	1 1/8	1 5/32	11/64	G1011KRRB		S1011K	0.56
GRFTD	GRFTDR	17														GE17KRRB		SE17K	
GRFTD	GRFTDR	3/4	90.5	71.4	60.3	8.7	54.8	43.7	19.8	26.6	9.1	10.7	33.3	34.1	6.4	G1012KRRB	Z956411 (T26790)	S1012K	0.386
GRFTD	GRFTDR	20	3 9/16	2 13/16	2 3/8	1 1/32	2 5/32	1 23/32	25/32	1 3/64	23/64	27/64	1 5/16	1 11/32	1/4	GE20KRRB		SE20K	0.85
GRFTD	GRFTDR	7/8														G1014KRRB		S1014K	
GRFTD	GRFTDR	15/16	95.2	76.2	66.7	8.7	60.3	44.4	19.8	27.0	9.1	10.7	38.1	38.9	6.7	G1015KRRB	Z956385 (T32544)	S1015K	0.386
GRFTD	GRFTDR	1	3 3/4	3	2 5/8	1 1/32	2 3/8	1 3/4	25/32	1 1/16	23/64	27/64	1 1/2	1 17/32	17/64	G1100KRRB		S1100K	0.85
GRFTD	GRFTDR	25														GE25KRRB		SE25K	
GRFTD	GRFTDR	1 1/16														G1101KRRB		S1101K	
GRFTD	GRFTDR	1 1/8														G1102KRRB		S1102K	
GRFTD	GRFTDR	1 3/16	112.7	90.5	78.6	10.3	71.4	48.4	22.2	30.2	10.7	11.9	44.5	46.0	6.4	G1103KRRB	Z956382 (T32984)	S1103K	0.712
GRFTD	GRFTDR	1 1/4 S	4 7/16	3 9/16	3 3/32	1 3/32	2 13/16	1 29/32	7/8	1 3/16	27/64	15/32	1 3/4	1 13/16	1/4	G1103KRRB3		S1103K3	1.57
GRFTD	GRFTDR	30														GE30KRRB		SE30K	
GRFTD	GRFTDR	1 1/4														G1104KRRB		S1104K	
GRFTD	GRFTDR	1 5/16	122.2	100.0	88.9	10.3	81.8	51.2	23.8	32.5	11.1	12.7	54.0	53.2	6.4	G1105KRRB	Z956396 (T26799)	S1105K	0.962
GRFTD	GRFTDR	1 3/8	4 13/16	3 15/16	3 1/2	1 3/32	3 7/32	2 1/64	15/16	1 9/32	7/16	1/2	2 1/8	2 3/32	1/4	G1106KRRB		S1106K	2.12
GRFTD	GRFTDR	1 7/16														G1107KRRB		S1107K	
GRFTD	GRFTDR	35														GE35KRRB		SE35K	

⁽¹⁾All units have a 1/4-28 grease fitting.
NOTE: Shaft diameter with an S = smaller housing.

PRESSED-STEEL MOUNTED BEARINGS

PBS SERIES

- The PBS series has an economical transmission unit for light-duty, moderate-speed requirements.
- The housing includes two heavy-gage, zinc-plated steel stampings. One is a standard stamping used in the MST two-bolt flangette unit.
- The RA-RRB (extended inner-ring) bearings are regularly furnished with this bearing. RR wide inner rings also can be used.
- The Timken Fafnir self-locking collar completes the assembly.
- This series is made with a precision bearing seat and dimensions are held to close tolerances. This provides an accurate bearing-to-housing fit and ensures proper alignment of parts.
- The RA-RRB bearing used in the PBS pillow block has positive-contact land-riding seals. It includes a shroud cap design and is permanently prelubricated.
- The base-to-center height and bolt spacing are interchangeable with many other pillow blocks on the market.

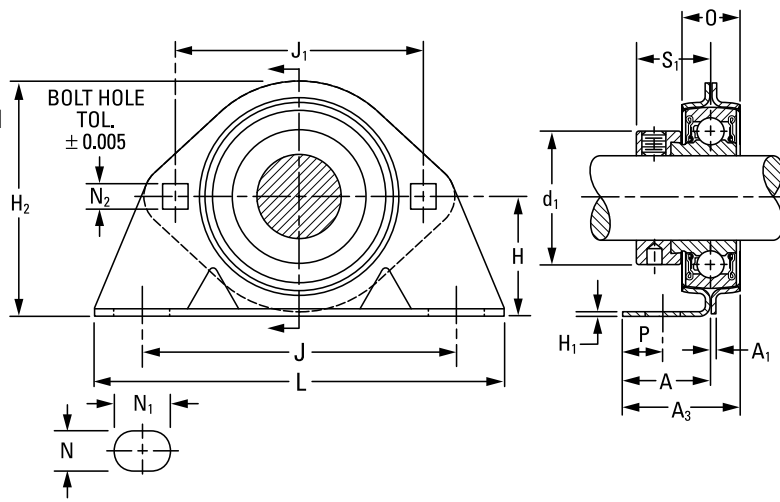

in.

To order, specify UNIT and SHAFT DIAMETER.

Example: PBS 1 7/16 in.

Suggested shaft tolerances: nominal to -0.013 mm, -0.0005

BEARING DATA

Unit	Bearing No.	Dimensions and Load Ratings
PBS	RA-RRB	Page 50

Unit	Shaft Dia.	Dimensions (mm)																Bearing No.	Flangette No.	Stamping Radial Load Rating ⁽¹⁾	Unit Wt.
		H	J	N ₁	L	H ₂	J ₁	d ₁	S ₁	O	A	H ₁	A ₁	A ₃	N ₂	P	N				
	in.	mm	mm	mm	mm	mm	mm	mm	mm	mm	mm	mm	mm	mm	mm	mm	mm			N	kg
	mm	in.	in.	in.	in.	in.	in.	in.	in.	in.	in.	in.	in.	in.	in.	in.	in.			lbs.	lbs.
PBS	1/2	30.2	92.1	15.9	123.8	59.5	63.5	28.6	22.2	14.3	25.4	2.64	1.90	32.5	7.1	10.3	10.3	RA008RRB	40 MST-(ZP)	2650 600	0.340 0.75
PBS	5/8	1 3/16	3 5/8	5/8	4 7/8	2 11/32	2 1/2	1 1/8	7/8	9/16	1	0.104	0.075	1 1/32	9/32	13/32	13/32	RA010RRB			
PBS	17																	RAE17RRB			
PBS	3/4	33.3	96.8	15.9	127.0	68.3	71.4	33.3	23.4	15.9	25.4	3.02	2.11	33.3	8.7	10.3	10.3	RA012RRB	47 MST-(ZP)	3100 700	0.440 0.97
PBS	20	1 5/16	3 13/16	5/8	5	2 11/16	2 13/16	1 5/16	59/64	5/8	1	0.119	0.083	1 1/16	1 1/32	13/32	13/32	RAE20RRB			
PBS	7/8																	RA014RRB	52 MST-(ZP)	3550 800	0.544 1.20
PBS	15/16	36.5	95.2	20.6	133.4	72.2	76.2	38.1	23.4	17.5	25.4	3.40	2.11	34.1	8.7	11.1	11.1	RA015RRB			
PBS	1	1 7/16	3 3/4	13/16	5 1/4	2 27/32	3	1 1/2	59/64	1 1/16	1	0.134	0.083	1 11/32	1 1/32	7/16	7/16	RA100RRB			
PBS	25																	RAE25RRB			
PBS	1 1/8																	RA102RRB	62 MST-(ZP)	3550 800	0.744 1.64
PBS	1 3/16	42.9	119.1	22.2	158.8	84.9	90.5	44.4	26.6	17.5	30.2	3.40	2.64	37.3	10.3	14.3	14.3	RA103RRB			
PBS	1 1/4 S	1 11/16	4 11/16	7/8	6 1/4	3 11/32	3 9/16	1 3/4	1 3/64	1 1/16	1 3/16	0.134	0.104	1 15/32	13/32	9/16	9/16	RA103RRB2			
PBS	30																	RAE30RRB			
PBS	1 1/4																	RA104RRB	72 MST-(ZP)	4000 900	1.089 2.40
PBS	1 3/8	47.6	127.0	22.2	165.1	94.5	100.0	54.0	29.4	22.2	34.9	3.78	2.64	46.0	10.3	14.3	14.3	RA106RRB			
PBS	1 7/16	1 7/8	5	7/8	6 1/2	3 23/32	3 15/16	2 1/8	1 5/32	7/8	1 3/8	0.149	0.104	1 13/16	13/32	9/16	9/16	RA107RRB			
PBS	35																	RAE35RRB			

⁽¹⁾Stamping thrust rating is 1/5 of stamping radial load rating.
NOTE: Shaft diameter with an S = smaller housing.

PB SERIES – RPB SERIES

- The PB series provides the advantages of ball bearings at an economical price.
- They are used for light-duty applications.
- The PB series consists of a two-piece separable zinc-plated steel housing with a spherical bearing seat. This allows the spherically ground bearing to have initial self-alignment in all directions.
- The ball bearing is an RA-RRB extended inner-ring-type with positive-contact, land-riding seals and a self-locking collar.
- The series incorporates an improved shroud-cap design and comes permanently prelubricated.
- RPB has the same construction as the PB-type, but with a thick, electrically conductive rubber inner liner.
- The bearings in the RPB unit are designated as RA-RRB FS450 and have a special ball and race finish for quiet operation.
- The RABR unit consists of the bearing with the rubber interliner.

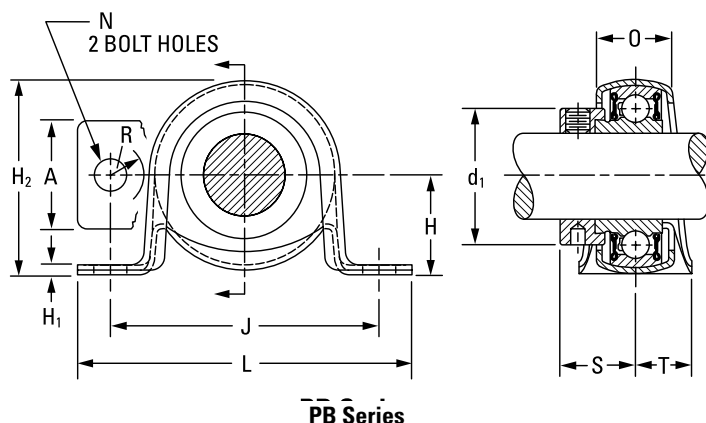

PB Series

Suggested shaft tolerances: nominal to -0.013 mm, -0.0005 in.

To order, specify UNIT and SHAFT DIAMETER.

Example: PB 1 3/16 in. or RPB 1 3/16 in.

BEARING DATA

Unit	Bearing No.	Dimensions and Load Ratings
PB	RA-RRB	Page 50
RPB	RA-RRB	Page 50

Unit	Shaft Dia.	H	H ₂	J	J	L	A	H ₁	N	R	d ₁	O	S ₁	T	Bearing No.	Collar No.	Stamping Radial Load Rating ⁽¹⁾	Unit Wt.
		mm	mm	mm	mm	mm	mm	mm	mm	mm	mm	mm	mm	mm				
PB	1/2	22.2	44.4	81.0	55.6	92.1	25.4	2.54	8.7	8.7	28.6	18.24	22.07	12.7	RA008RRB	S1008K	300	0.200
PB	5/8	27.8	55.6	109.2	74.0	114.3	31.8	3.18	10.3	10.3	33.3	21.82	23.44	15.9	RA010RRB	S1010K	300	0.44
PB	17	22.2	44.4	81.0	55.6	92.1	25.4	2.54	8.7	8.7	28.6	18.24	22.07	12.7	RAE17RRB	SE17K	300	0.44
PB	3/4	25.4	52.4	88.9	63.5	104.8	25.4	2.54	10.3	10.3	33.3	21.82	23.44	15.9	RA012RRB	S1012K	350	0.259
PB	20	25.4	52.4	88.9	63.5	104.8	25.4	2.54	10.3	10.3	33.3	21.82	23.44	15.9	RAE20RRB	SE20K	350	0.57
PB	7/8	28.6	56.4	100.0	71.4	114.0	28.6	5.28	10.3	10.3	38.1	25.40	23.44	14.3	RA014RRB	S1014K	400	0.295
PB	15/16	28.6	56.4	100.0	71.4	114.0	28.6	5.28	10.3	10.3	38.1	25.40	23.44	14.3	RA015RRB	S1015K	400	0.65
PB	1	33.3	66.7	133.4	89.0	127.0	31.8	3.18	10.3	10.3	44.5	25.40	26.72	19.0	RA100RRB	S1100K	600	1.05
PB	1 1/16	33.3	66.7	133.4	89.0	127.0	31.8	3.18	10.3	10.3	44.5	25.40	26.72	19.0	RAE25RRB	SE25K	600	1.05
PB	1 1/8	33.3	66.7	133.4	89.0	127.0	31.8	3.18	10.3	10.3	44.5	25.40	26.72	19.0	RA101RRB	S1101K	600	1.05
PB	1 1/16	33.3	66.7	133.4	89.0	127.0	31.8	3.18	10.3	10.3	44.5	25.40	26.72	19.0	RA102RRB	S1102K	600	1.05
PB	1 3/16	33.3	66.7	133.4	89.0	127.0	31.8	3.18	10.3	10.3	44.5	25.40	26.72	19.0	RA103RRB	S1103K	600	1.05
PB	1 1/4 S	33.3	66.7	133.4	89.0	127.0	31.8	3.18	10.3	10.3	44.5	25.40	26.72	19.0	RA103RRB2	S1103K3	600	1.05
PB	30	33.3	66.7	133.4	89.0	127.0	31.8	3.18	10.3	10.3	44.5	25.40	26.72	19.0	RAE30RRB	SE30K	600	1.05

⁽¹⁾Housing thrust rating is 1/3 of housing radial load rating. Maximum suggested speed is 2400 RPM.
 NOTE: Shaft diameter with an S = smaller housing.
 NOTE: Load ratings are upright mounted capacities with load direction toward base.
 NOTE: These units should not be mounted vertically or upside down.

MOUNTED BALL BEARINGS

PRESSED-STEEL MOUNTED BEARINGS • PB, RPB

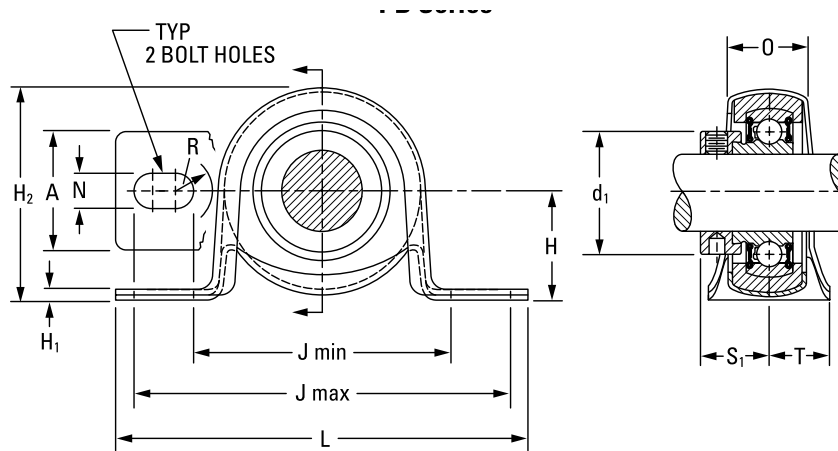

RPB Series

Unit	Shaft Dia.														Bearing No. ⁽¹⁾	Collar No.	Stamping Radial Load Rating ⁽²⁾	Unit Wt.
		H	H ₂	J max.	J min.	L	A	H ₁	N	R	d ₁	O	S ₁	T				
	in. mm	mm in.	mm in.	mm in.	mm in.	mm in.	mm in.	mm in.	mm in.	mm in.	mm in.	mm in.	mm in.	mm in.			N lbs.	kg lbs.
RPB	1/2														RA008RRB	S1008K		
RPB	5/8	25.40	52.4	88.9	63.5	104.8	25.4	2.54	10.3	10.3	28.6	21.59	22.07	15.9	RA010RRB	S1010K	880	0.200
RPB	17	1	2 1/16	3 1/2	2 1/2	4 1/8	1	0.100	13/32	13/32	1 1/8	0.85	0.869	5/8	RAE17RRB	SE17K	200	0.44
RPB	3/4	28.58	56.4	100.0	71.4	114.0	28.6	5.28	10.3	10.3	33.3	25.40	23.44	14.3	RA012RRB	S1012K	1120	0.259
RPB	20	1 1/8	2 7/32	3 5/16	2 13/16	4 1/2	1 1/8	0.208	13/32	13/32	1 5/16	1.00	0.923	9/16	RAE20RRB	SE20K	250	0.57
RPB	7/8														RA014RRB	S1014K		
RPB	15/16	33.34	66.7	104.8	76.2	123.8	31.8	3.68	10.3	10.3	38.1	25.40	23.44	19.0	RA015RRB	S1015K	1340	0.295
RPB	1	1 5/16	2 5/8	4 1/8	3	4 7/8	1 1/4	0.145	13/32	13/32	1 1/2	1.00	0.923	3/4	RA100RRB	S1100K	300	0.65
RPB	25														RAE25RRB	SE25K		
LRPB	1 3/16	33.34	66.7	104.8	76.2	123.8	31.8	3.68	10.3	10.3	44.4	25.40	28.30	19.0	RAL103NPPB	LS103K	1340	0.476
		1 5/16	2 5/8	4 1/8	3	4 7/8	1 1/4	0.145	13/32	13/32	1 3/4	1.00	1.114	3/4			300	1.05

⁽¹⁾Bearing suffix number FS450.

⁽²⁾Housing thrust rating is 1/3 of housing radial load rating. Maximum suggested speed is 2400 RPM.

PRESSED-STEEL FLANGED UNITS VFMST SERIES

- The zinc-plated, pressed-metal flange unit is assembled with an RA-RR prelubricated extended inner-ring-type bearing.
- The unit is ideal for light-duty applications.
- The unit features flush-mounting.
- The unit has additional contamination protection.
- The VFMST series is self-aligning.

Suggested shaft tolerances:

nominal to -0.013 mm, -0.0005 in.

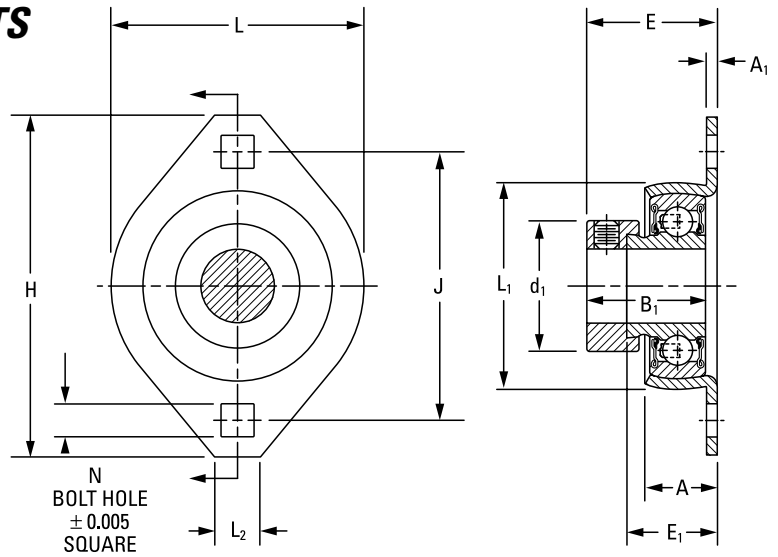

BEARING DATA

Unit	Bearing No.	Dimensions and Load Ratings
VFMST	RA-RRB	Page 50

Unit	Shaft Dia.														Bearing No.	Collar No.	Stamping	
		H	J	L	E	A	N	L ₁	E ₁	L ₂	B ₁	d ₁	A ₁	Size			Radial Load Rating ⁽¹⁾	
	in. mm	mm in.	mm in.	mm in.	mm in.	mm in.	mm in.	mm in.	mm in.	mm in.	mm in.	mm in.	mm in.				N lbs.	
VFMST	3/4	90.5	71.4	66.7	33.3	16.7	8.7	50.8	23.0	12.7	31.0	33.3	2.64	RA012RRB	S1012K	47FMST	2240 500	
VFMST	20	3 9/16	2 13/16	2 5/8	1 5/16	2 1/32	1 1/32	2	29/32	1/2	1 7/32	1 5/16	0.104	RAE20RRB	SE20K			
VFMST	7/8	95.2	76.2	71.0	33.3	18.3	8.7	55.6	23.8	12.7	31.0	38.1	2.64	RA014RRB	S1014K	52FMST	2650 600	
VFMST	15/16													RA015RRB	S1015K			
VFMST	1	3 3/4	3	2 51/64	1 5/16	23/32	1 1/32	2 3/16	1 5/16	1/2	1 7/32	1 1/2	0.104	RA100RRB	S1100K			
VFMST	25	RAE25RRB	SE25K															
VFMST	1 1/8	112.7	90.5	84.1	38.9	23.0	10.3	66.7	27.8	15.9	35.7	44.4	3.40	RA102RRB	S1102K	62FMST	3550 800	
VFMST	1 3/16													RA103RRB	S1103K			
VFMST	1 1/4 S													RA103RRB2	S1103K3			
VFMST	30													RAE30RRB	SE30K			

⁽¹⁾Housing thrust rating is 1/3 of housing radial load rating.
NOTE: Shaft diameter with an S = smaller housing.

LFST SERIES

- This unit is zinc-plated, pressed-steel and flush-mounted.
- This unit simplifies bearing flange-unit installations.
- The conductive rubber interliner reduces noise and vibration. This allows for alignment while the pressed-steel flange assures rigid bearing support.
- The bolt-hole spacing permits interchangeability with competitive mountings.
- The unit offers compact, economical, corrosion-resistant housing and balanced design.
- The unit features Timken Fafnir RAL light-series ball bearings. The RAL provides precision in an extended inner-ring bearing with superior shroud seal protection and self-locking collar.
- The bearings are prelubricated.

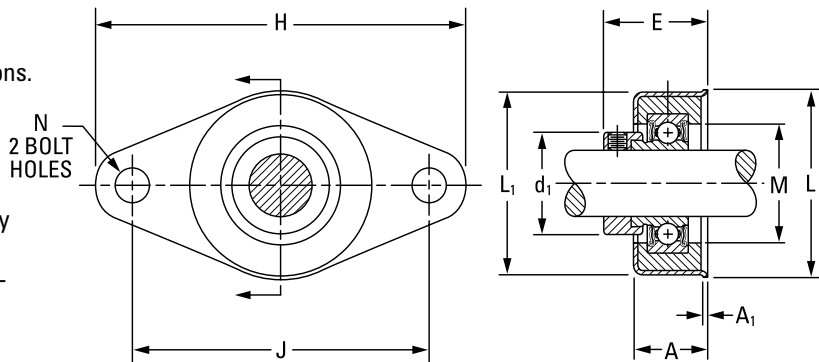

Suggested shaft tolerances:

nominal to -0.013 mm, -0.0005 in.

To order, specify UNIT and SHAFT DIAMETER.

Example: LFST 1 in.

BEARING DATA

Unit	Bearing No.	Dimensions and Load Ratings
LFST	RAL-NPP	Page 57

Unit	Shaft Dia.	H	J	L	L ₁	E	N	A	A ₁	d ₁	M	Bearing No.	Collar No.	Housing Radial Load Rating ⁽¹⁾
	in.	mm in.	mm in.	mm in.	mm in.	mm in.	mm in.	mm in.	mm in.	mm in.	mm in.			N lbs.
LFST	1/2	114.3 4 1/2	92.1 3 5/8	57.2 2 1/4	55.6 2 3/16	31 1 7/32	9.5 3/8	23 29/32	1.52 0.06	25.4 1	29.4 1 5/32	RAL008NPP	LS008K	880 200
LFST	5/8	114.3 4 1/2	92.1 3 5/8	57.2 2 1/4	55.6 2 3/16	31 1 7/32	9.5 3/8	23 29/32	1.52 0.06	29.8 1 11/64	34.9 1 3/8	RAL010NPP	LS010K	1120 250
LFST	3/4	114.3 4 1/2	92.1 3 5/8	57.2 2 1/4	55.6 2 3/16	31 1 7/32	9.5 3/8	23 29/32	1.52 0.06	36.1 1 27/64	39.7 1 9/16	RAL012NPP	LS012K	1340 300
LFST	15/16	114.3 4 1/2	92.1 3 5/8	57.2 2 1/4	55.6 2 3/16	31 1 7/32	9.5 3/8	23 29/32	1.52 0.06	36.1 1 27/64	39.7 1 9/16	RAL015NPP	LS015K	1340 300
LFST	1	114.3 4 1/2	92.1 3 5/8	57.2 2 1/4	55.6 2 3/16	31 1 7/32	9.5 3/8	23 29/32	1.52 0.06	36.1 1 27/64	39.7 1 9/16	RAL100NPP	LS100K	1340 300

⁽¹⁾Housing thrust rating is 1/3 of housing radial load rating. Maximum suggested speed is 2400 RPM.

PRESSED-STEEL FLANGETTE UNITS

RR FLANGETTE UNIT

- The unit consists of two interchangeable, pressed-steel, zinc-plated flanges housing a standard bearing with a self-locking collar.
- The spherical inside surfaces of each pair of flanges mate with the spherical outside surface of the bearing's outer ring. This provides initial self-alignment.
- The flangette is equipped with the KRRB (R-seal) wide-inner-ring ball bearing.
- All units are non-relubricatable.

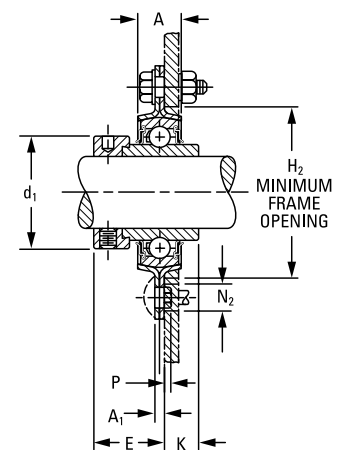
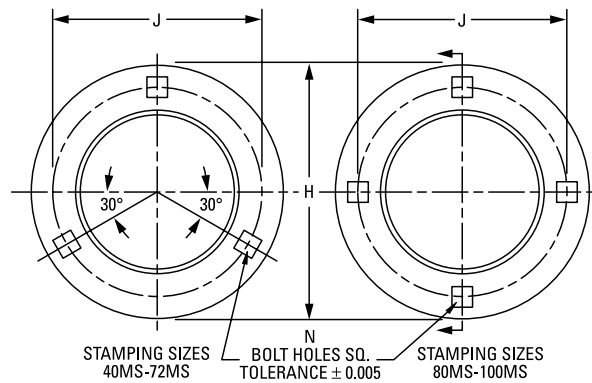

Suggested shaft tolerances:

- 1/2 in. – 1 15/16 in., nominal to -0.013 mm, -0.0005 in.;
- 2 in. – 2 15/16 in., nominal to -0.025 mm, -0.0010 in.

BEARING DATA

Unit	Bearing No.	Dimensions and Load Ratings
RR	KRRB	Page 34

Unit	Shaft Dia.											Bolt Size	Short Shank	Long Shank	Flange Hole Diam. to Clear Sq. Shank	Bearing No.	Collar No.	Stamping ⁽¹⁾		Unit Wt.
		H	A	J	N	H ₂	A ₁	E	K	d ₁	P							N ₂	Size	
	in. mm	mm in.	mm in.	mm in.	mm in.	mm in.	mm in.	mm in.	mm in.	mm in.	mm in.	mm in.	mm in.	mm in.	mm in.			N lbs.	kg lbs.	
RR	1/2																			
RR	5/8	81.0	14.2	63.5	7.1	49.2	3.80	25.4	11.9	28.6	6.4	0.15	2.54	10.3	1008KRRB	S1008K	40MS	2650	0.295	
RR	17	3 3/16	9/16	2 1/2	9/32	1 15/16	0.150	1	15/32	1 1/8	1/4	0.006	0.100	13/32	E17KRRB	SE17K	600	0.65		
RR	3/4	90.5	15.8	71.4	8.7	55.6	4.22	28.6	15.1	33.3	7.9	0.53	2.92	12.7	1012KRRB	S1012K	47MS	3100	0.404	
RR	20	3 3/16	5/8	2 13/16	11/32	2 3/16	0.166	1 1/8	19/32	1 5/16	5/16	0.021	0.115	1/2	E20KRRB	SE20K	700	0.89		
RR	7/8																			
RR	15/16	95.2	17.4	76.2	8.7	60.3	4.22	28.6	15.1	38.1	7.9	0.53	2.92	12.7	1014KRRB	S1014K	52MS	3550	0.490	
RR	1	3 3/4	1 1/16	3	11/32	2 3/8	0.166	1 1/8	19/32	1 1/2	5/16	0.021	0.115	1/2	1015KRRB	S1015K	800	1.08		
RR	25																			
RR	1 1/8																			
RR	1 3/16	112.7	17.4	90.5	10.3	71.4	5.28	32.5	15.9	44.5	9.5	0.28	2.64	15.1	1102KRRB	S1102K	62MS	4900	0.753	
RR	1 1/4 S	4 7/16	1 1/16	3 9/16	13/32	2 13/16	0.208	1 9/32	5/8	1 3/4	3/8	0.011	0.104	19/32	1103KRRB	S1103K	1100	1.66		
RR	30																			
RR	1 1/4																			
RR	1 5/16	122.2	19.0	100.0	10.3	81.0	5.28	34.9	15.9	54.0	9.5	0.28	2.64	15.1	1104KRRB	S1104K	72MS	6220	0.962	
RR	1 3/8	4 13/16	3/4	3 15/16	13/32	3 3/16	0.208	1 3/8	5/8	2 1/8	3/8	0.011	0.104	19/32	1105KRRB	S1105K	1400	2.12		
RR	1 7/16																			
RR	35																			

⁽¹⁾Stampings must be ordered in pairs to assemble bearing.
⁽²⁾Thrust ratings for stamping are 50 percent of radial ratings.
 NOTE: Shaft diameter with an S = smaller housing.

Continued on next page.

MOUNTED BALL BEARINGS

PRESSED-STEEL FLANGETTE UNITS • RR

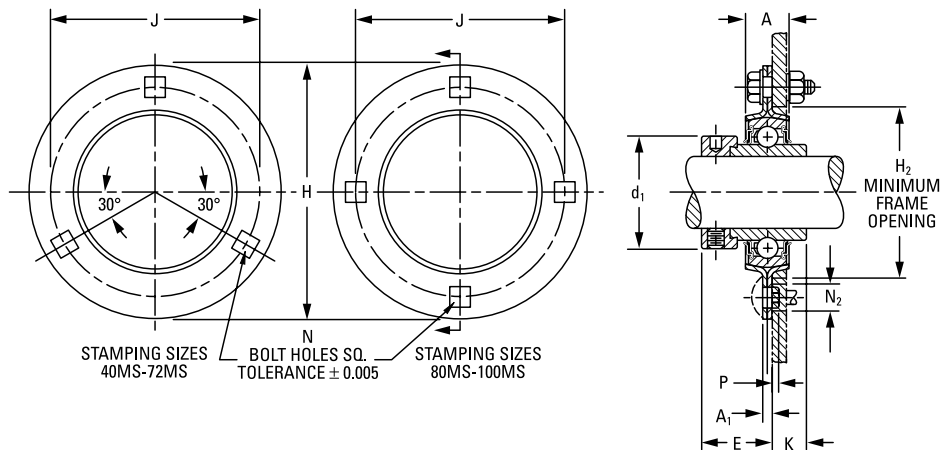

Continued from previous page.

Unit	Shaft Dia.										Bolt Size	Short Shank	Long Shank	Flange Hole Diam. to Clear Sq. Shank	Bearing No.	Collar No.	Stamping ⁽¹⁾		Unit Wt.			
		H	A	J	N	H ₂	A ₁	E	K	d ₁		P					N ₂	Size		Radial Load Rating ⁽²⁾		
	in. mm	mm in.	mm in.	mm in.	mm in.	mm in.	mm in.	mm in.	mm in.	mm in.	mm in.	mm in.	mm in.	mm in.				N lbs.	kg lbs.			
RR	1 1/2																					
RR	1 9/16	147.6	20.6	119.1	13.5	90.5	6.80	38.1	18.3	60.3	12.7	0.33	2.72	19.4	1108KRRB	S1108KT	80MS	7500	1.143			
RR	40	5 13/16	13/16	4 11/16	17/32	3 9/16	0.268	1 1/2	23/32	2 3/8	1/2	0.013	0.107	49/64	E40KRRB	SE40K				1700	2.52	
RR																						
RR	1 5/8																					
RR	1 11/16	149.2	22.2	120.6	13.5	96.8	6.80	38.1	18.3	63.5	12.7	0.33	2.72	19.4	1110KRRB	S1110K	85MS	7500	1.651			
RR	45	5 7/8	7/8	4 3/4	17/32	3 13/16	0.268	1 1/2	23/32	2 1/2	1/2	0.013	0.107	49/64	E45KRRB	SE45K				1700	3.64	
RR																						
RR	1 7/8																					
RR	1 15/16	155.6	22.2	127.0	13.5	101.6	7.56	42.1	20.6	69.8	12.7	0	1.96	19.4	1114KRRB	S1114K	90MS	8500	1.878			
RR	50	6 1/8	7/8	5	17/32	4	0.298	1 21/32	13/16	2 3/4	1/2	0	0.077	49/64	E50KRRB	SE50K				1900	4.14	
RR																						
RR	2																					
RR	2 1/8	166.7	23.8	138.1	13.5	112.7	7.56	47.6	23.8	76.2	12.7	0	1.96	19.4	1200KRRB	S1200K	100MS	10200	2.268			
RR	55	6 9/16	15/16	5 1/16	17/32	4 7/16	0.298	1 7/8	15/16	3	1/2	0	0.077	49/64	E55KRRB	SE55K				2300	5.00	
RR																						
RR																						

⁽¹⁾Thrust ratings for stamping are 50 percent of radial ratings.

⁽²⁾Stampings must be ordered in pairs to assemble bearing.

NOTE: Shaft diameter with an S = smaller housing.

RA FLANGETTE UNIT

- The RA flangette unit is similar to Timken Fafnir RR flangette unit.
- The unit consists of two interchangeable, pressed-steel, zinc-plated flanges that house a standard ball bearing.
- The unit incorporates an extended inner-ring bearing with a self-locking collar and spherical seat in the cartridge, providing initial self-alignment.
- The unit is equipped with an RA-RRB extended inner ring ball bearing.
- The units are non-relubricatable.

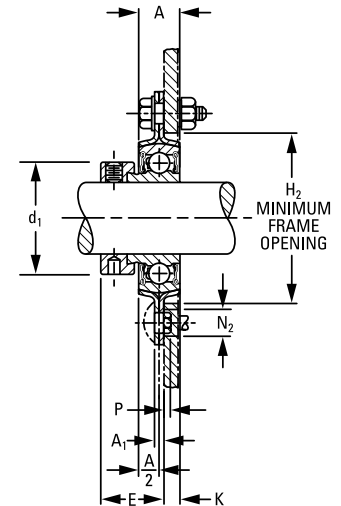
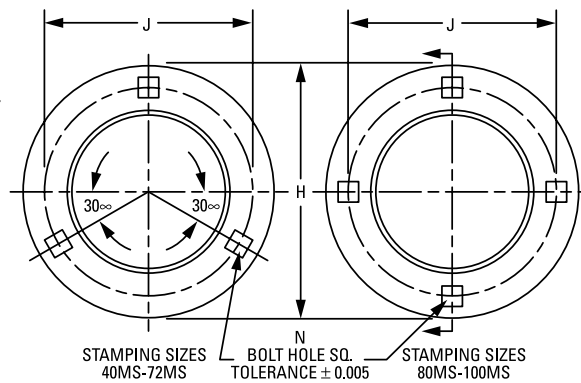

Suggested shaft tolerances:

- 1/2 in. – 1 15/16 in., nominal to -0.013 mm, -0.0005 in.;
- 2 in. – 2 3/16 in., nominal to -0.025 mm, -0.0010 in.

To order, specify UNIT and SHAFT DIAMETER.

Example: RA 1 in. flangette.

BEARING DATA

Unit	Bearing No.	Dimensions and Load Ratings
RA	RA-RRB	Page 50

Unit	Shaft Dia.	Dimensions									Bolt Size	Short Shank		Long Shank	Flange Hole Diam. to Clear Sq. Shank	Bearing No.	Collar No.	Stamping ⁽¹⁾		Unit Wt.
		H	A	J	N	H ₂	A ₁	E	K	d ₁		P	N ₂					Size	Radial Load Rating ⁽²⁾	
	in. mm	mm in.	mm in.	mm in.	mm in.	mm in.	mm in.	mm in.	mm in.	mm in.	mm in.	mm in.	mm in.	mm in.				N lbs.	kg lbs.	
RA	1/2																			
RA	9/16	81.0	14.2	63.5	7.1	49.2	3.81	23.8	5.6	28.6	6.4	0.15	2.54	10.3	RA008RRB	S1008K	40MS	2650 600	0.277 0.61	
	5/8	3 3/16	9/16	2 1/2	9/32	1 15/16	0.150	15/16	7/32	1 1/8	1/4	0.006	0.100	13/32	RA009RRB	S1009K				
	17														RA010RRB	S1010K				
RA	3/4	90.5	15.8	71.4	8.7	55.6	4.22	25.0	6.4	33.3	7.9	0.53	2.92	12.7	RAE17RRB	SE17K				
RA	20	3 9/16	5/8	2 13/16	1 1/32	2 3/16	0.166	63/64	1/4	1 9/16	5/16	0.021	0.115	1/2	RA012RRB	S1012K	47MS	3100 700	0.363 0.80	
															RAE20RRB	SE20K				
RA	7/8	95.2	17.4	76.2	8.7	60.3	4.22	25.0	7.1	38.1	7.9	0.53	2.92	12.7	RA013RRB	S1013K	52MS	3550 800	0.408 0.90	
RA	15/16	3 3/4	1 1/16	3	1 1/32	2 3/8	0.166	63/64	9/32	1 1/2	5/16	0.021	0.115	1/2	RA014RRB	S1014K				
RA	1														RA015RRB	S1015K				
RA	25														RA100RRB	S1100K				
															RAE25RRB	SE25K				
RA	1 1/16														RA101RRB	S1101K	62MS	4900 1100	0.667 1.47	
RA	1 1/8	112.7	17.4	90.5	10.3	71.4	5.28	29.0	6.7	44.5	9.5	0.28	2.64	15.1	RA102RRB	S1102K				
RA	1 3/16	4 7/16	1 1/16	3 9/16	13/32	2 13/16	0.208	1 9/64	17/64	1 3/4	3/8	0.011	0.104	19/32	RA103RRB	S1103K				
RA	1 1/4 S														RA103RRB3	S1103K3				
RA	30														RAE30RRB	SE30K				
RA	1 1/4														RA104RRB	S1104K	72MS	6220 1400	0.889 1.96	
RA	1 5/16	122.2	19.0	100.0	10.3	81.0	5.28	31.8	7.5	54	9.5	0.28	2.64	15.1	RA105RRB	S1105K				
RA	1 3/8	4 13/16	3/4	3 15/16	13/32	3 3/16	0.208	1 1/4	19/64	2 1/8	3/8	0.011	0.104	19/32	RA106RRB	S1106K				
RA	1 7/16														RA107RRB	S1107K				
RA	35														RAE35RRB	SE35K				

⁽¹⁾Stampings must be ordered in pairs to assemble bearing.

⁽²⁾Thrust ratings for stamping are 50 percent of radial ratings.

NOTE: Shaft diameter with an S = smaller housing.

Continued on next page.

MOUNTED BALL BEARINGS

PRESSED-STEEL FLANGETTE UNITS • RA

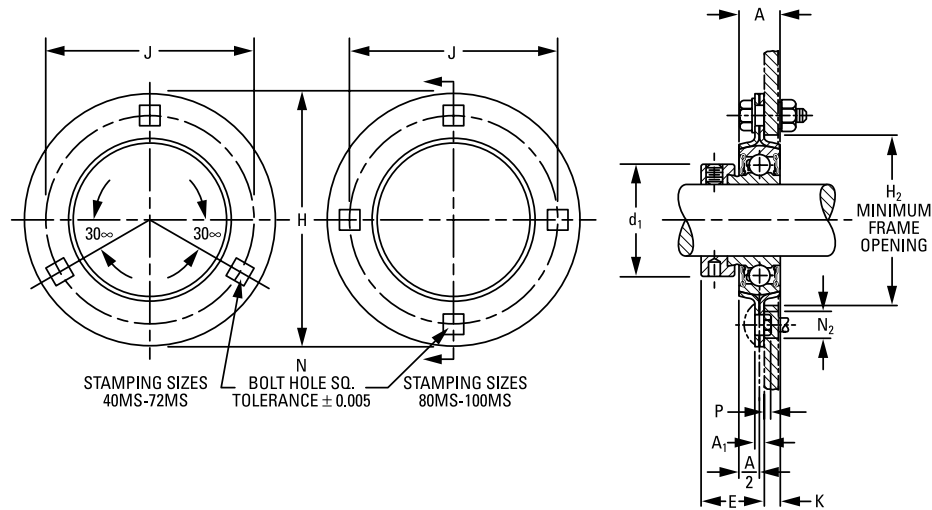

Continued from previous page.

Unit	Shaft Dia.											Bolt Size	Short Shank	Long Shank	Flange Hole Diam. to Clear Sq. Shank	Bearing No.	Collar No.	Stamping ⁽¹⁾		Unit Wt.
		H	A	J	N	H ₂	A ₁	E	K	d ₁	P							N ₂	Size	
	in. mm	mm in.	mm in.	mm in.	mm in.	mm in.	mm in.	mm in.	mm in.	mm in.	mm in.	mm in.	mm in.	mm in.			N lbs.	kg lbs.		
RA	1 1/2																			
RA	1 9/16	147.6	20.6	119.1	13.5	90.5	6.80	36.1	7.5	60.3	12.7	0.33	2.72	19.4	RA108RRB	S1108KT	80MS	7500	1.447	
RA	40	5 13/16	13/16	4 11/16	17/32	3 9/16	0.268	1 27/64	19/64	2 3/8	1/2	0.013	0.107	49/64	RA109RRB	S1109KT				
															RAE40RRB	SE40K				
RA	1 5/8																			
RA	1 11/16	149.2	22.2	120.6	13.5	96.8	6.80	36.1	7.5	63.5	12.7	0.33	2.72	19.4	RA110RRB	S1110K	85MS	7500	1.479	
RA	1 3/4	5 7/8	7/8	4 3/4	17/32	3 13/16	0.268	1 27/64	19/64	2 1/2	1/2	0.013	0.107	49/64	RA111RRB	S1111K				
															RA112RRB	S1112K				
RA	45																			
RA	1 13/16																			
RA	1 7/8	155.6	22.2	127.0	13.5	101.6	7.56	36.5	7.1	69.8	12.7	0	1.96	19.4	RA113RRB	S1113K	90MS	8500	1.669	
RA	1 15/16	6 1/8	7/8	5	17/32	4	0.300	1 7/16	9/32	2 3/4	1/2	0	0.077	49/64	RA114RRB	S1114K				
RA	50														RA115RRB	S1115K				
															RAE50RRB	SE50K				
RA	2																			
RA	2 1/16	166.7	23.8	138.1	13.5	112.7	7.56	40.5	8.3	76.2	12.7	0	1.96	19.4	RA200RRB	S1200K	100MS	10200	2.000	
RA	2 1/8	6 9/16	15/16	5 7/16	17/32	4 7/16	0.300	1 19/32	29/64	3	1/2	0	0.077	49/64	RA201RRB	S1201K				
RA	2 3/16														RA202RRB	S1202K				
															RA203RRB	S1203K				
RA	55														RAE55RRB	SE55K				

⁽¹⁾Stampings must be ordered in pairs to assemble bearing.

⁽²⁾Thrust ratings for stamping are 50 percent of radial ratings.

NOTE: Shaft diameter with an S = smaller housing.

RAT, RRT TWO-BOLT FLANGETTE UNITS

- These units are designed for installations where the standard three-bolt flangettes cannot be used due to space limitations.
- Like standard three-bolt flangettes, they are available with RA-RRB extended inner ring ball bearings and the KRRB wide-inner-ring ball bearings (RRT) with self-locking collars.
- All units are non-relubricatable.

Suggested shaft tolerances:

1/2 in. – 1 7/16 in.,
nominal to -0.013 mm, -0.0005 in.;

To order, specify UNIT and SHAFT DIAMETER.

Example: RAT 1 in. flangette or RRT 1 in. flangette.

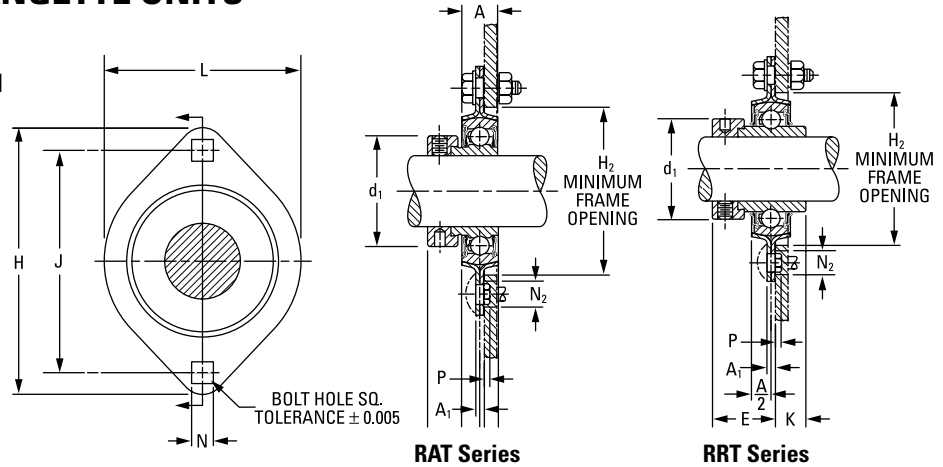

BEARING DATA

Unit	Bearing No.	Dimensions and Load Ratings
RAT	RA-RRB	Page 50
RRT	-KRRB	Page 34

Unit	Shaft Dia.	Dimensions										Bolt Size	Shank		Flange Hole Diam. to Clear Sq. Shank	Bearing No.	Collar No.	Stamping ⁽¹⁾		Unit Wt.
		L	H	A	J	N	H ₂	A ₁	E	K	d ₁		P	N ₂				Size	Radial Load Rating ⁽²⁾	
	in. mm	mm in.	mm in.	mm in.	mm in.	mm in.	mm in.	mm in.	mm in.	mm in.	mm in.	mm in.	mm in.	mm in.	mm in.	mm in.			N lbs.	kg lbs.
RAT	1/2	58.7	81.0	14.2	63.5	7.1	49.2	3.81	23.8	5.6	28.6	6.4	0.15	2.54	10.3	RA008RRB	S1008K			
RAT	5/8	2 5/16	3 3/16	9/16	2 1/2	9/32	1 15/16	0.150	1 5/16	7/32	1 1/8	1/4	0.006	0.100	13/32	RA010RRB	S1010K	40MST	2650	0.213
RAT	17															RAE17RRB	SE17K		600	0.47
RAT	3/4	66.7	90.5	15.8	71.4	8.7	55.6	4.22	25.0	6.4	33.3	7.9	0.53	2.92	12.7	RA012RRB	S1012K			
RAT	20	2 5/8	3 9/16	5/8	2 13/16	1 1/32	2 3/16	0.166	63/64	1/4	1 5/16	5/16	0.021	0.115	1/2	RAE20RRB	SE20K	47MST	3100	0.299
RAT	7/8															RA014RRB	S1014K			
RAT	1 5/16	71.0	95.2	17.4	76.2	8.7	60.3	4.22	25.0	7.1	38.1	7.9	0.53	2.92	12.7	RA015RRB	S1015K			
RAT	1	2 51/64	3 3/4	1 1/16	3	1 1/32	2 3/8	0.166	63/64	9/32	1 1/2	5/16	0.021	0.115	1/2	RA100RRB	S1100K	52MST	3550	0.331
RAT	25															RAE25RRB	SE25K		800	0.73
RAT	1 1/16															RA101RRB	S1103K			
RAT	1 1/8															RA102RRB	S1102K			
RAT	1 3/16	84.1	112.7	17.4	90.5	10.3	71.4	5.28	29.0	6.7	44.5	9.5	0.28	2.64	15.1	RA103RRB	S1103K			
RAT	1 1/4 S	3 5/16	4 7/16	1 1/16	3 9/16	1 3/32	2 13/16	0.208	1 9/64	1 7/64	1 3/4	3/8	0.011	0.104	1 9/32	RA103RRB2	S1103K3	62MST	4900	0.531
RAT	30															RAE30RRB	SE30K		1100	1.17
RAT	1 1/4															RA104RRB	S1104K			
RAT	1 5/16															RA105RRB	S1105K			
RAT	1 3/8	93.7	125.4	22.2	100.0	10.3	81.0	5.28	32.1	6.7	54.0	9.5	0.28	2.64	15.1	RA106RRB	S1106K			
RAT	1 7/16	3 11/16	4 15/16	7/8	3 15/16	1 3/32	3 3/16	0.208	1 17/64	1 7/64	2 1/8	3/8	0.011	0.104	1 9/32	RA107RRB	S1107K	72MST	6220	0.476
RAT	35															RAE35RRB	SE35K		1400	1.05

⁽¹⁾Stampings must be ordered in pairs to assemble bearing.

⁽²⁾Thrust ratings for stamping are 50 percent of radial ratings.

NOTE: Shaft diameter with an S = smaller housing.

Continued on next page.

MOUNTED BALL BEARINGS

PRESSED-STEEL FLANGETTE UNITS • RAT, RRT

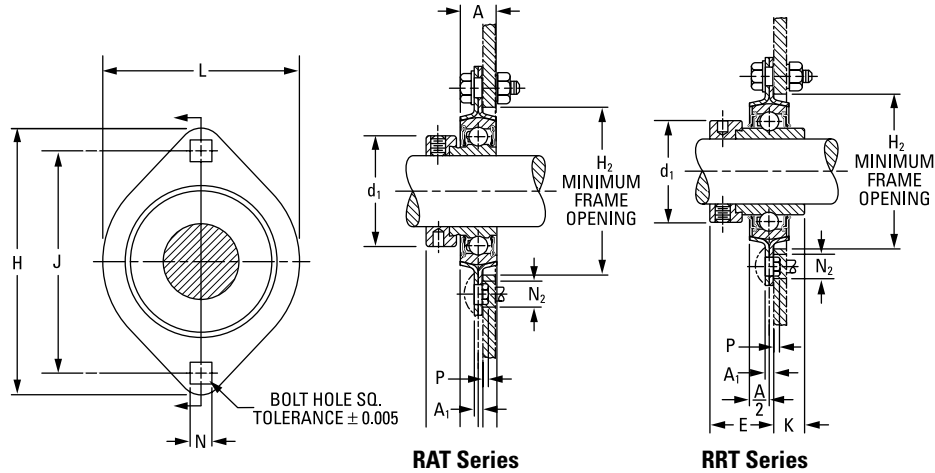

Continued from previous page.

Unit	Shaft Dia.											Bolt Size	Short Shank	Long Shank	Flange Hole Diam. to Clear Sq. Shank	Bearing No.	Collar No.	Stamping ⁽¹⁾		Unit Wt.	
		L	H	A	J	N	H ₂	A ₁	E	K	d ₁		P					N ₂	Size		Radial Load Rating ⁽²⁾
	in. mm	mm in.	mm in.	mm in.	mm in.	mm in.	mm in.	mm in.	mm in.	mm in.	mm in.	mm in.	mm in.	mm in.	mm in.	mm in.	mm in.			N lbs.	kg lbs.
RRT	1/2	58.7	81.0	14.2	63.5	7.1	49.2	3.81	23.8	5.6	28.6	6.4	0.15	2.54	10.3	1008KRBB	S1008K	40MST	2650 600	0.213 0.47	
RRT	5/8	2 5/16	3 3/16	9/16	2 1/2	9/32	1 15/16	0.150	1 5/16	7/32	1 1/8	1/4	0.006	0.100	13/32	1010KRRB	S1010K				
RRT	17															E17KRRB	SE17K				
RRT	3/4	66.7	90.5	15.8	71.4	8.7	55.6	4.22	25.0	6.4	33.3	7.9	0.53	2.92	12.7	1012KRRB	S1012K	47MST	3100 700	0.299 0.66	
RRT	20	2 5/8	3 9/16	5/8	2 13/16	1 1/32	2 3/16	0.166	63/64	1/4	1 5/16	5/16	0.021	0.115	1/2	E20KRRB	SE20K				
RRT	7/8	71.0	95.2	17.4	76.2	8.7	60.3	4.22	25.0	7.1	38.1	7.9	0.53	2.92	12.7	1014KRRB	S1014K	52MST	3550 800	0.331 0.73	
RRT	15/16	2 51/64	3 3/4	1 1/16	3	1 1/32	2 3/8	0.166	63/64	9/32	1 1/2	5/16	0.021	0.115	1/2	1015KRRB	S1015K				
RRT	1															1100KRRB	S1100K				
RRT	25															E25KRRB	SE25K				
RRT	1 1/16	84.1	112.7	17.4	90.5	10.3	71.4	5.28	29.0	6.7	44.5	9.5	0.28	2.64	15.1	1101KRRB	S1103K	62MST	4900 1100	0.531 1.17	
RRT	1 1/8	3 5/16	4 7/16	1 1/16	3 9/16	13/32	2 13/16	0.208	1 9/64	17/64	1 3/4	3/8	0.011	0.104	19/32	1102KRRB	S1102K				
RRT	1 3/16															1103KRRB	S1103K				
RRT	1 1/4 S															1103KRRB3	S1103K3				
RRT	30															E30KRRB	SE30K				
RRT	1 1/4	93.7	125.4	22.2	100.0	10.3	81.0	5.28	32.1	6.7	54.0	9.5	0.28	2.64	15.1	1104KRRB	S1104K	72MST	6220 1400	0.476 1.05	
RRT	1 5/16	3 11/16	4 15/16	7/8	3 15/16	13/32	3 3/16	0.208	1 17/64	17/64	2 1/8	3/8	0.011	0.104	19/32	1105KRRB	S1105K				
RRT	1 3/8															1106KRRB	S1106K				
RRT	1 7/16															1107KRRB	S1107K				
RRT	35															E35KRRB	SE35K				

⁽¹⁾Stampings must be ordered in pairs to assemble bearing.

⁽²⁾Thrust ratings for stamping are 50 percent of radial ratings.

NOTE: Shaft diameter with an S = smaller housing.

RATR, RRTR TRIANGLE FLANGETTE UNITS

- These units are similar to standard 47MS, 52MS, 62MS and 72MS, except the stamping is triangular instead of round.
- These units are used where space is limited or where it is necessary to cut off one or more sides of the standard flangette stamping.
- The RA-RRB and KRRB may be used with this stamping, as with other types of flangettes.
- All units are non-relubricatable.

Suggested shaft tolerances:

1/2 in. – 1 7/16 in., nominal to -0.013 mm, -0.0005 in.;

To order, specify UNIT and SHAFT DIAMETER.

Example: RATR 1 in. flangette or RRTR 1 in. flangette.

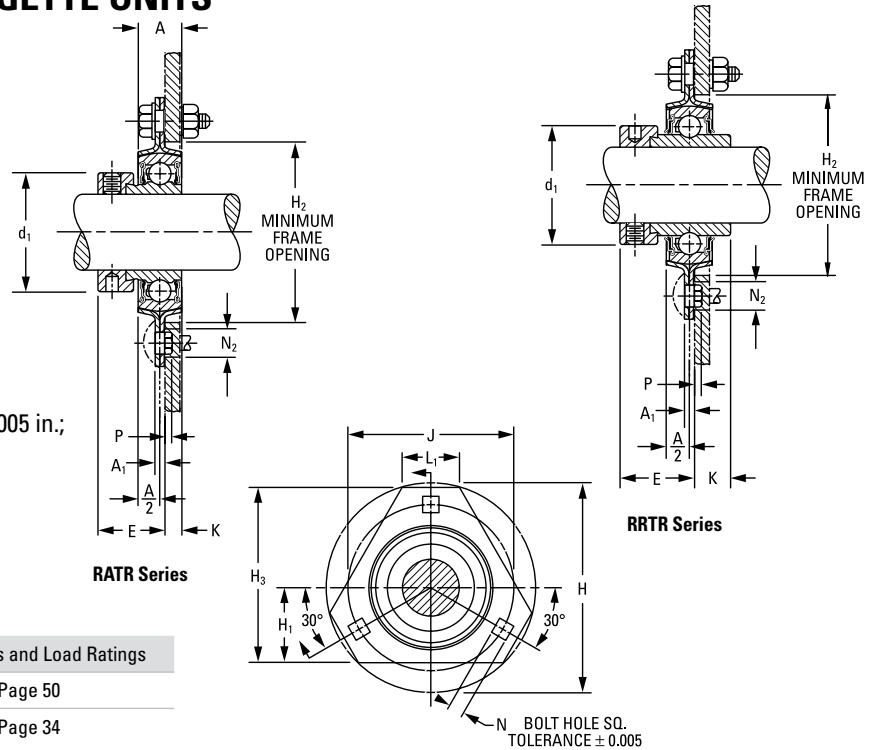

BEARING DATA

Unit	Bearing No.	Dimensions and Load Ratings
RATR	RA-RRB	Page 50
RRTR	-KRRB	Page 34

Unit	Shaft Dia.	Dimensions and Load Ratings													Bolt Size	Short Shank	Long Shank	Flange Hole Diam. to Clear Sq. Shank	Bearing No.	Collar No.	Stamping ⁽¹⁾		Unit Wt.															
		H ₃	H	A	J	N	H ₂	A ₁	E	K	d ₁	H ₁	L ₁	P							N ₂	Size		Radial Load Rating ⁽²⁾														
	in. mm	mm in.	mm in.	mm in.	mm in.	mm in.	mm in.	mm in.	mm in.	mm in.	mm in.	mm in.	mm in.	mm in.	mm in.	mm in.	mm in.	mm in.			N lbs.	kg lbs.																
RATR	3/4	76.2	90.5	15.8	71.4	8.7	55.6	4.22	25.0	6.4	33.3	33.3	27.0	7.9	0.15	2.54	12.7	RA012RRB	S1012K	47MSTR	3100 700	0.313 0.69																
RATR	20	3	3 9/16	5/8	2 13/16	11/32	2 3/16	0.166	63/64	1/4	1 5/16	1 5/16	1 1/16	5/16	0.006	0.100	1/2	RAE20RRB	SE20K																			
RATR	7/8	79.4	95.2	17.4	76.2	8.7	60.3	4.22	25.0	7.1	38.1	34.9	27.8	7.9	0.53	2.92	12.7	RA014RRB	S1014K	52MSTR	3550 800	0.354 0.78																
RATR	15/16																	RA015RRB	S1015K																			
RATR	1																	3 1/8	3 3/4				11/16	3	11/32	2 3/8	0.166	63/64	9/32	1 1/2	1 3/8	1 3/32	5/16	0.021	0.115	1/2	RA100RRB	S1100K
RATR	25																	RAE25RRB	SE25K																			
RATR	1 1/16	93.7	112.7	17.4	90.5	10.3	71.4	5.28	29.0	6.7	44.5	38.1	25.4	9.5	0.28	2.64	15.1	RA101RRB	S1103K	62MSTR	4900 1100	0.526 1.16																
RATR	1 1/8																	RA102RRB	S1102K																			
RATR	1 3/16																	3 11/16	4 7/16				11/16	3 9/16	13/32	2 13/16	0.208	1 9/64	17/64	1 3/4	1 1/2	1	3/8	0.011	0.104	19/32	RA103RRB	S1103K
RATR	1 1/4 S																																				RA103RRB2	S1103K3
RATR	30																																				RAE30RRB	SE30K
RATR	1 1/4	105.6	127.0	19.0	100.0	10.3	81.0	5.28	32.1	6.7	54.0	44.4	32.1	9.5	0.028	2.64	15.1	RA104RRB	S1104K	72MSTR	6300 1400	0.703 1.55																
RATR	1 5/16																	RA105RRB	S1105K																			
RATR	1 3/8																	4 5/32	5				3/4	3 15/16	13/32	3 3/16	0.208	1 17/64	17/64	2 1/8	1 3/4	1 17/64	3/8	0.011	0.104	19/32	RA106RRB	S1106K
RATR	1 7/16																																				RA107RRB	S1107K
RATR	35																																				RAE35RRB	SE35K

⁽¹⁾Stampings must be ordered in pairs to assemble bearing.

⁽²⁾Thrust ratings for stamping are 50 percent of radial ratings.

NOTE: Shaft diameter with an S = smaller housing.

Continued on next page.

MOUNTED BALL BEARINGS

PRESSED-STEEL FLANGETTE UNITS • RATR, RRTR

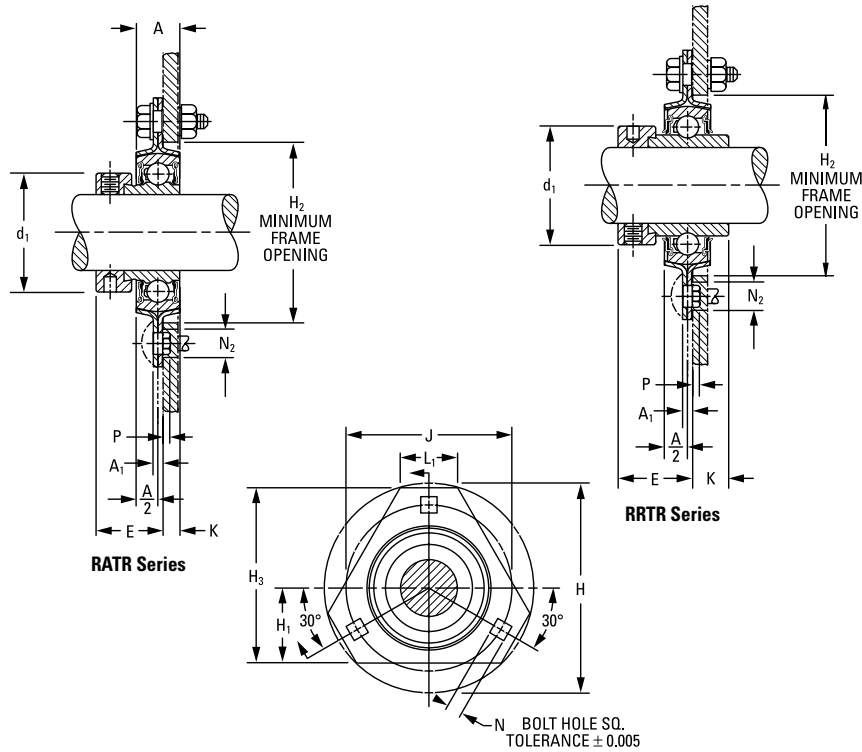

Continued from previous page.

Unit	Shaft Dia.												Bolt Size	Short Shank	Long Shank	Flange Hole Diam. to Clear Sq. Shank	Bearing No.	Collar No.	Stamping ⁽¹⁾		Unit Wt.	
		H ₃	H	A	J	N	H ₂	A ₁	E	K	d ₁	H ₁							L ₁	P		N ₂
	in. mm	mm in.	mm in.	mm in.	mm in.	mm in.	mm in.	mm in.	mm in.	mm in.	mm in.	mm in.	mm in.	mm in.	mm in.	mm in.				N lbs.	kg lbs.	
RRTR	3/4	76.2	90.5	15.8	71.4	8.7	55.6	4.22	28.6	15.1	33.3	33.3	2.07	7.9	0.15	2.54	12.7	1012KRRB	S1012K	47MSTR	3100 700	0.313 0.69
RRTR	20	3	3 9/16	5/8	2 13/16	1 1/32	2 3/16	0.166	1 1/8	1 9/32	1 5/16	1 5/16	1 1/16	5/16	0.006	0.100	1/2	E20KRRB	SE20K			
RRTR	7/8	79.4	95.2	17.4	76.2	8.7	60.3	4.22	28.6	15.1	38.1	34.9	27.8	7.9	0.53	2.92	12.7	1014KRRB	S1014K	52MSTR	3550 800	0.354 0.78
RRTR	1 5/16																	1015KRRB	S1015K			
RRTR	1																	1100KRRB	S1100K			
RRTR	25	E25KRRB	SE25K																			
RRTR	1 1/16	93.7	112.7	17.4	90.5	10.3	71.4	5.28	32.5	15.9	44.5	38.1	25.4	9.5	0.28	2.64	15.1	1101KRRB	S1103K	62MSTR	4900 1100	0.526 1.16
RRTR	1 1/8																	1102KRRB	S1102K			
RRTR	1 3/16																	1103KRRB	S1103K			
RRTR	1 1/4 S																	1103KRRB3	S1103K3			
RRTR	30																	E30KRRB	SE30K			
RRTR	1 1/4	105.6	127.0	19.0	100.0	10.3	81.0	5.28	34.9	16.3	54.0	44.4	32.1	9.5	.028	2.64	15.1	1104KRRB	S1104K	72MSTR	6300 1400	0.703 1.55
RRTR	1 5/16																	1105KRRB	S1105K			
RRTR	1 3/8																	1106KRRB	S1106K			
RRTR	1 7/16																	1107KRRB	S1107K			
RRTR	35																	E35KRRB	SE35K			

⁽¹⁾Stampings must be ordered in pairs to assemble bearing.

⁽²⁾Thrust ratings for stamping are 50 percent of radial ratings.

NOTE: Shaft diameter with an S = smaller housing.

GRA, GRR RELUBRICATABLE FLANGETTE UNITS

- These units are supplements to the standard non-relubricatable type.
- These units are zinc-plated and designed for relubrication in applications where excessive moisture and severe contamination are present.
- The relubricatable flangettes are dimensionally interchangeable with the non-relubricated types. Load ratings also are the same.
- The relubricatable units incorporate G-KRRB bearings and GRA-RRB inner-ring bearings with positive-contact, land-riding seals and self-locking collars.
- The two stampings are needed to make a complete relubricatable flangette. Stamping A contains the boss for the grease fitting and a grease groove to allow grease to enter holes in the outer ring of the bearing. Stamping B contains a similar groove for the same purpose. With the grease groove in both stampings, the bearing can be reversed in the housing and still be relubricated.

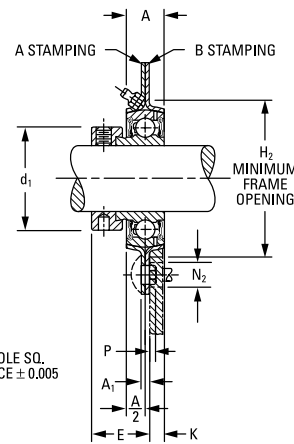
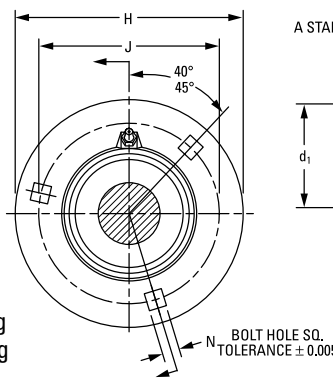

GRA Series

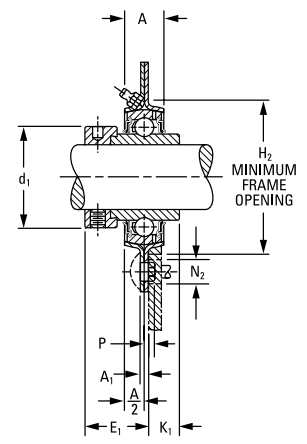

GRR Series

Suggested shaft tolerances:

- 1/2 in. – 1 15/16 in., nominal to -0.013 mm, -0.0005 in.;
- 2 in. – 2 3/16 in., nominal to -0.025 mm, -0.0010 in.

To order, specify UNIT and SHAFT DIAMETER.

Example: GRA 1 in. flangette.

BEARING DATA

Unit	Bearing No.	Dimensions and Load Ratings
GRA	GRA-RRB	Page 52
GRR	G-KRRB	Page 36

Unit	Shaft Dia.	Dimensions											Short Shank	Long Shank	Flange Hole Diam. to Clear Sq. Shank	Bearing No.		Collar No.	Stamping Radial Load Rating ⁽¹⁾				
		H	A	J	N	H ₂	A ₁	E	E ₁	K	K ₁	d ₁				P	N ₂			(GRA)	(GRR)		
	in. mm	mm in.	mm in.	mm in.	mm in.	mm in.	mm in.	mm in.	mm in.	mm in.	mm in.	mm in.	mm in.	mm in.	mm in.	mm in.				N lbs.			
G52MSA & G52MSB	13/16																						
	7/8																						
	15/16	95.2	17.40	76.2	8.7	60.3	4.22	25.4	29.0	6.7	13.5	38.1	0.53	2.92	12.7			GRA013RRB	G1013KRRB	S1013K	7700 1730		
	1	3 3/4	1 1/16	3	1 1/32	2 3/8	0.166	1	1 9/64	1 7/64	1 7/32	1 1/2	0.021	0.115	1/2			GRA014RRB	G1014KRRB	S1014K			
	25																						
G62MSA & G62MSB	1 1/16																						
	1 1/8	112.7	19.05	90.5	10.3	71.4	5.28	29.4	32.9	6.7	15.5	44.1	0.28	2.64	15.1			GRA101RRB	G1101KRRB	S1103K	11100 2500		
	1 3/16	4 7/16	3/4	3 9/16	1 3/32	2 13/16	0.208	1 5/32	1 19/64	1 7/64	3 9/64	1 47/64	0.011	0.104	19/32			GRA102RRB	G1102KRRB	S1102K			
	1 1/4 S																						
	30																						
G72MSA & G72MSB	1 1/4																						
	1 5/16	122.2	22.20	100.0	10.3	81.0	6.80	32.9	35.7	7.9	15.5	54.0	0.28	2.64	15.1			GRA104RRB	G1104KRRB	S1104K	15100 3400		
	1 3/8	4 13/16	7/8	3 15/16	1 3/32	3 3/16	0.268	1 19/64	1 13/32	5/16	3 9/64	2 1/8	0.011	0.104	19/32			GRA105RRB	G1105KRRB	S1105K			
	1 7/16																						
	35																						

⁽¹⁾Thrust ratings for stampings are 50 percent of radial ratings.

⁽²⁾Four bolt holes.

NOTE: Shaft diameter with an S = smaller housing.

Continued on next page.

MOUNTED BALL BEARINGS

PRESSED-STEEL FLANGETTE UNITS • GRA, GRR

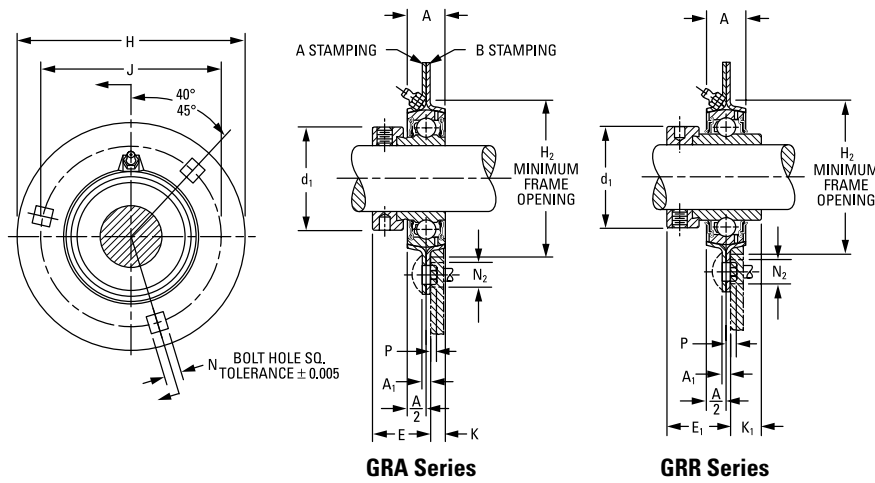

Continued from previous page.

Unit	Shaft Dia.												Short Shank	Long Shank	Flange Hole Diam. to Clear Sq. Shank	Bearing No.		Collar No.	Stamping Radial Load Rating ⁽¹⁾	
		H	A	J	N	H ₂	A ₁	E	E ₁	K	K ₁	d ₁				P	N ₂			(GRA)
	in. mm	mm in.	mm in.	mm in.	mm in.	mm in.	mm in.	mm in.	mm in.	mm in.	mm in.	mm in.	mm in.	mm in.	mm in.	mm in.				N lbs.
G80MSA ⁽²⁾ & G80MSB ⁽²⁾	1 1/2	147.6 5 13/16	31.80 1 1/4	119.1 4 11/16	13.5 17/32	90.4 3 9/16	7.56 0.298	36.5 1 7/16	38.9 1 17/32	12.3 31/64	17.9 45/64	60.3 2 3/8	0.33 0.013	2.72 0.107	19.4 49/64	GRA108RRB	G1108KRRB	S1108KT	19600 4400	
	1 9/16															GRA109RRB	G1109KRRB	S1109KT		
	40															GRAE40RRB	GE40KRRB	SE40K		
G85MSA ⁽²⁾ & G85MSB ⁽²⁾	1 5/8	149.2 5 7/8	31.8 1 1/4	120.6 4 3/4	13.5 17/32	96.8 3 13/16	7.56 0.298	36.5 1 7/16	38.9 1 17/32	11.9 15/32	17.9 45/64	63.5 2 1/2	0.33 0.013	2.72 0.107	19.4 49/64	GRA110RRB	G1110KRRB	S1110K	20500 4600	
	1 11/16															GRA111RRB	G1111KRRB	S1111K		
	1 3/4															GRA112RRB	G1112KRRB	S1112K		
	45															GRAE45RRB	GE45KRRB	SE45K		
G90MSA ⁽²⁾ & G90MSB ⁽²⁾	1 13/16	155.6 6 1/8	25.4 1	127.0 5	13.5 17/32	101.6 4	8.34 0.328	36.9 1 29/64	42.5 1 43/64	8.3 21/64	20.6 13/16	69.8 2 3/4	—	1.96 0.077	19.4 49/64	GRA113RRB	G1113KRRB	S1113K	22700 5100	
	1 7/8															GRA114RRB	G1114KRRB	S1114K		
	1 15/16															GRA115RRB	G1115KRRB	S1115K		
	50															GRAE50RRB	GE50KRRB	SE50K		
G100MSA & G100MSB	2	166.7 6 9/16	31.8 1 1/4	138.1 5 7/16	13.5 17/32	112.7 4 7/16	8.34 0.328	40.5 1 19/32	47.6 1 7/8	11.9 15/32	23.8 15/16	76.2 3	—	1.96 0.077	19.4 49/64	GRA200RRB	G1200KRRB	S1200K	28500 6400	
	2 1/16															GRA201RRB	G1201KRRB	S1201K		
	2 1/8															GRA202RRB	G1202KRRB	S1202K		
	2 3/16															GRA203RRB	G1203KRRB	S1203K		
	55															GRAE55RRB	GE55KRRB	SE55K		

⁽¹⁾Thrust ratings for stampings are 50 percent of radial ratings.

⁽²⁾Four bolt holes.

NOTE: Shaft diameter with an S = smaller housing.

RUBBER CARTRIDGES

RCSM, RCR, CR SERIES

- RCSM and RCR are quiet, synthetic, conductive-rubber cylindrical cartridges designed for domestic heating, air-conditioning, ventilating equipment and other applications that require noise-free operation.
- All units are available with the RA-RRB extended inner-ring bearings with positive-contact, land-riding seals and a self-locking collar.

- An initial supply of grease is provided in the one-piece, non-relubricatable cartridges.
- The Timken Fafnir-patented CR unit was designed to accommodate the wide tolerances of hot or cold rolled #10-gage (0.134 in.), 3 1/2 in. O.D., electric-resistance welded mechanical tubing, similar to what is found in post office conveyor systems.

To order, specify UNIT and SHAFT DIAMETER.

Example: RCSM 3/4 in. or RCR 3/4 in. or CR 3/4 in.

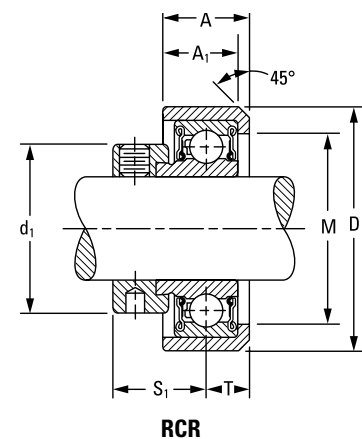
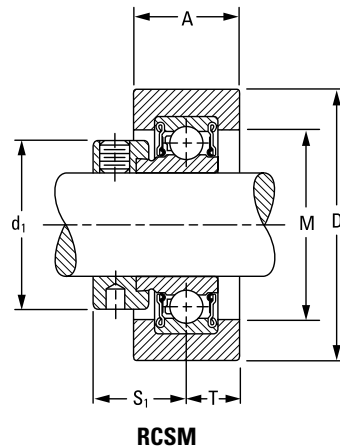
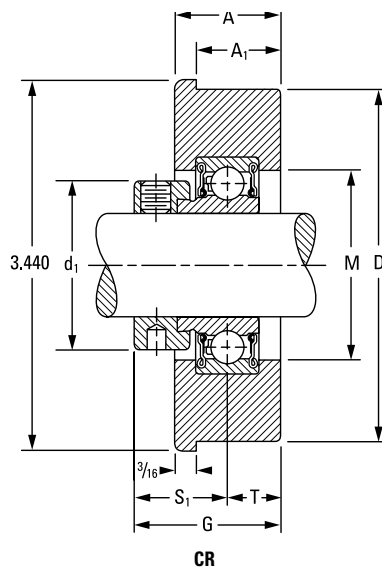

BEARING DATA

Unit	Bearing No.	Dimensions and Load Ratings
RCSM, RCR, CR	RA-RR	Page 50

Unit	Shaft Dia.	D	A	A ₁	G	M	d ₁	S ₁	T	Bearing No. ⁽¹⁾	Collar No.	Housing Radial Load Rating ⁽²⁾	Unit Wt.
	in. mm	mm in.	mm in.	mm in.	mm in.	mm in.	mm in.	mm in.	mm in.			N lbs.	kg lbs.
RCSM SERIES – Suggested Housing Diameter = Nominal D ± 0.013 mm ± 0.005 in.													
RCSM	1/2	64.30	25.4	—	—	34.9	28.6	22.2	12.7	RA008RR	S1008K	880	0.395
RCSM	5/8	64.30	25.4	—	—	34.9	28.6	22.2	12.7	RA010RR	S1010K	200	0.87
RCSM	17	217/32	1	—	—	1 3/8	1 1/8	7/8	1/2	RAE17RR	SE17K		
RCSM	3/4	64.30	25.4	—	—	39.7	33.3	23.4	12.7	RA012RR	S1012K	1120	0.472
RCSM	20	217/32	1	—	—	1 9/16	1 5/16	59/64	1/2	—	SE20K	250	1.04
RCSM	15/16	64.30	25.4	—	—	45.2	38.1	23.4	12.7	RA015RR	S1015K	1340	0.527
RCSM	1	64.30	25.4	—	—	45.2	38.1	23.4	12.7	RA100RR	S1100K	300	1.16
RCSM	25	217/32	1	—	—	1 25/32	1 1/2	59/64	1/2	RAE25RR	SE25K		
LRCSM	1 3/16	64.30	25.4	—	—	47.6	42.1	19.8	12.7	RAL103NPP	LS103K	1340	0.627
		217/32	1	—	—	1 7/8	1 21/32	25/32	1/2			300	1.38
RCSM SERIES – Suggested Housing Diameter = Nominal D -0.13 mm to -0.038 mm, -0.005 in. to -0.0015 in.													
LRCR	3/4	46.00	18.3	15.9	—	34.9	30.2	18.7	9.9	RAL012NPP	LS012K	880	0.272
		1 13/16	23/32	5/8	—	1 3/8	1 3/16	47/64	25/64			200	0.60
RCR	1	57.20	19.8	17.5	—	44.4	38.1	23.4	9.9	RA100RR	S1100K	1340	0.409
RCR	25	2 1/4	25/32	1 1/16	—	1 3/4	1 1/2	59/64	25/64	RAE25RR	SE25K	300	0.90
RCSM SERIES – Suggested Housing Diameter 82.73 mm to 81.76 mm, 3.257 in. to 3.219 in.													
CR	3/4	83.57	25.4	22.2	36.1	39.7	33.3	23.4	12.7	RA012RR	S1012K	670	0.318
CR	20	3.29	1	7/8	1 27/64	1 9/16	1 5/16	59/64	1/2	RAE20RR	SE20K	150	0.70
CR	1	83.57	25.4	22.2	36.1	45.2	38.1	23.4	12.7	RA100RR	S1100K	880	0.340
CR	25	3.29	1	7/8	1 27/64	1 25/32	1 1/2	59/64	1/2	RAE25RR	SE25K	200	0.75
LCR	1	83.57	25.4	20.6	33.3	39.7	36.1	19.8	14.3	RAL100NPP	S1100K	880	0.309
LCR	25	3.29	1	13/16	1 3/16	1 9/16	1 27/64	25/32	9/16	RALE25NPP	SE25K	200	0.68

⁽¹⁾Suffix for RA bearing is FS450 (RCSM and RCR series).

⁽²⁾Steady loads only. Thrust load is 1/3 radial load rating. Maximum suggested speed is 2400 RPM.

RABR HVAC SPECIAL SERIES

- This unit features a conductive rubber interliner to dissipate static charges.
- The quiet RA-RRB extended inner-ring bearings are prelubricated and have positive-contact, land-riding seals with self-locking collars.
- RABR units can be mounted in tri-arm brackets or pressed-steel stampings.
- Maximum suggested speed is 2400 RPM.

Suggested housing diameter =

Nominal (D) -0.130 mm – 0.380 mm; -0.005 in. – 0.015 in.

To order, specify UNIT and SHAFT DIAMETER.

Example: RABR 1 in.

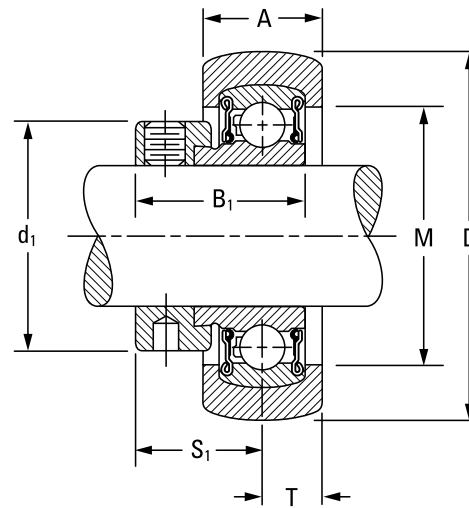

BEARING DATA

Unit	Bearing No.	Dimensions and Load Ratings
RABR	RA-RRB	Page 50

Unit	Shaft Dia.	D	B ₁	A	M	d ₁	S ₁	T	Bearing No. ⁽¹⁾	Collar No.	Housing Radial Load Rating ⁽²⁾
	in. mm	mm in.	mm in.	mm in.	mm in.	mm in.	mm in.	mm in.			N lbs.
RABR	1/2								RA008RRB	S1008K	
RABR	5/8	47.37 1.865	28.6 1 1/8	17.5 11/16	34.9 1 3/8	28.6 1 1/8	22.2 7/8	8.7 11/32	RA010RRB	S1010K	880 200
RABR	17								RAE17RRB	SE17K	
RABR	3/4	52.37 2.062	31.0 1 7/32	17.5 11/16	41.3 1 5/8	33.3 1 5/16	23.4 59/64	8.7 11/32	RA012RRB	S1012K	1120 250
RABR	20								RAE20RRB	SE20K	
RABR	15/16								RA015RRB	S1015K	
RABR	1	62.38 2.456	31.0 1 7/32	20.6 13/16	46.8 1 27/32	38.1 1 1/2	23.4 59/64	10.3 13/32	RA100RRB	S1100K	1340 300
RABR	25								RAE25RRB	SE25K	
RABR	1 3/16	62.38 2.456	35.7 1 13/32	20.6 13/16	46.8 1 27/32	44.4 1 3/4	28.6 1 1/8	10.3 13/32	RAL103PP	LS103K	1340 300
RABR	30								RAE30PP3	SE30K	

⁽¹⁾For replacement of bearings, specify suffix FS450.

⁽²⁾Thrust load is 1/3 radial load rating.

NOTE: Maximum suggested speed is 2400 RPM.

TAKE-UP UNITS

NLTU SERIES SIDE-MOUNTED, PRESSED-STEEL

- The take-up frame incorporates RTU take-up units as shown on the following pages.
- The frame is designed for side mounting and made of welded steel.

To order a complete assembly, specify **NLTU FRAME** and **RTU TAKE-UP UNIT**.

Example: NLTU5 frame and RTU 1 11/16 in. If frame only is required, order by frame number. Example: NLTU3.

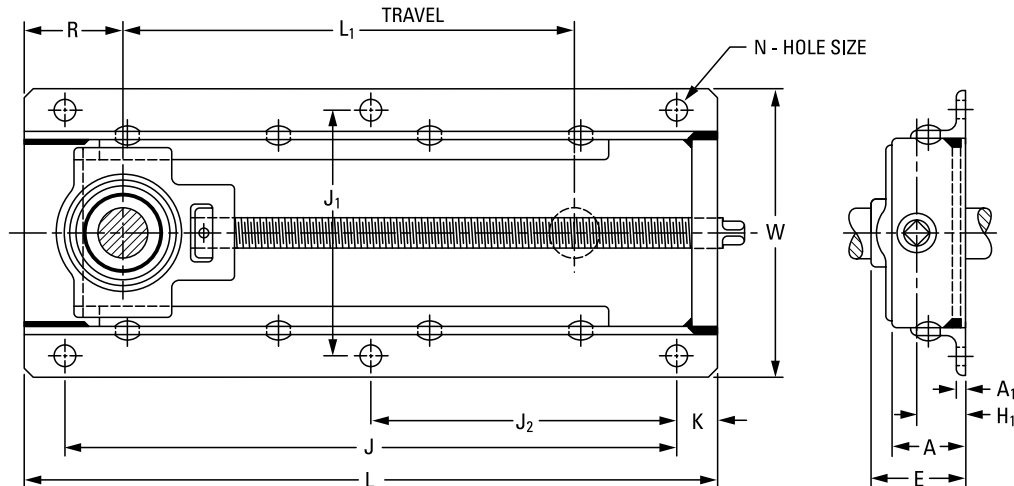

NLTU Frame No.	Shaft Dia.	L ₁	R	J	L	A ₁	H ₁	E	J ₁	W	A	J ₂	K	N	Bolts 6 req'd.	Unit Wt.
		mm in.	mm in.	mm in.	mm in.	mm in.	mm in.	mm in.	mm in.	mm in.	mm in.	mm in.	mm in.	mm in.		
1	5/16, 3/4, 13/16, 7/8, 15/16, 1	231.8	62.70	327.0	377.8	4.8	27.0	54.0	141.3	166.7	44.4	163.5	25.4	12.7	7/16	3.691 8.13
		9 1/8	2 15/32	12 7/8	14 7/8	3/16	1 1/16	2 1/8	5 9/16	6 9/16	1 3/4	6 7/16	1	1/2		
3	1 1/16, 1 1/8, 1 3/16, 1 1/4, 1 5/16, 1 3/8, 1 7/16	290.5	64.23	392.1	432.2	4.8	31.8	61.9	154.0	179.4	50.8	196.1	25.4	12.7	7/16	5.003 11.02
		11 7/16	2 17/32	15 7/16	17 7/16	3/16	1 1/4	2 7/16	6 1/16	7 1/16	2	7 23/32	1	1/2		
		290.5	61.90	392.1	432.2	4.8	31.8	64.3	154	179.4	50.8	196.1	25.4	12.7	7/16	
5	1 1/2, 1 9/16, 1 5/8, 1 11/16, 1 3/4, 1 13/16, 1 7/8, 1 15/16	298.4	92.90	444.5	501.6	4.8	36.5	71.4	185.7	223.8	57.2	222.5	28.6	14.3	1/2	8.217 18.10
		11 3/4	3 21/32	17 1/2	19 3/4	3/16	1 7/16	2 13/16	7 5/16	8 13/16	2 1/4	8 3/4	1 1/8	9/16		
7	2, 2 1/16, 2 1/8, 2 3/16, 2 1/4, 2 5/16, 2 3/8, 2 7/16	362.0	92.90	546.1	603.2	4.8	38.1	81.8	219.1	265.1	63.5	273.0	28.6	15.9	9/16	12.312 27.12
		14 1/4	3 21/32	21 1/2	23 3/4	3/16	1 1/2	3 7/32	8 5/8	10 7/16	2 1/2	10 3/4	1 1/8	5/8		
		362.0	92.90	546.1	603.2	4.8	38.1	84.9	219.1	265.1	63.5	273.0	28.6	15.9	9/16	
		14 1/4	3 21/32	21 1/2	23 3/4	3/16	1 1/2	3 11/32	8 5/8	10 7/16	2 1/2	10 3/4	1 1/8	5/8		

TU SERIES

TOP-MOUNTED, CAST-IRON

- The take-up frame incorporates RTU take-up units as shown on the following pages.
- The frame is designed for top mounting and is made of cast-iron.

To order a complete assembly, specify **TU FRAME** and **RTU** or **TU TAKE-UP UNIT**.

Example: TU5 frame and RTU 1 11/16 in.

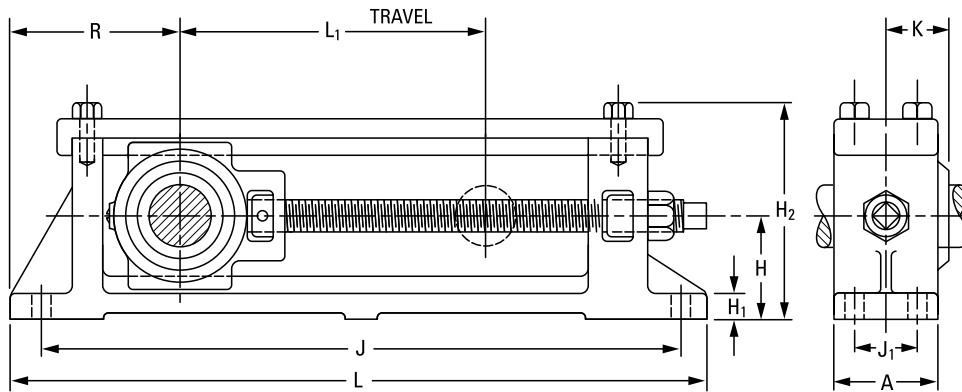

TU Frame No.	Shaft Dia.	L ₁	R	J	L	H ₁	H	H ₂	J ₁	A	K	Bolts 4 req'd.	Unit Wt.
		mm in.	mm in.	mm in.	mm in.	mm in.	mm in.	mm in.	mm in.	mm in.	mm in.		in.
1	3/4, 13/16, 7/8, 15/16, 1	203.2 8	114.3 4 1/2	419.2 16 1/2	469.9 18 1/2	14.3 9/16	63.5 2 1/2	131.0 5 5/32	34.9 1 3/8	54.0 2 1/8	—	3/8	7.491 16.50
3	1 1/16, 1 1/8, 1 3/16, 1 1/4, 1 5/16, 1 3/8, 1 7/16	254.0 10	127.0 5	492.1 19 3/8	542.9 21 3/8	15.9 5/8	71.4 2 13/16	149.2 5 7/8	38.1 1 1/2	65.1 2 9/16	—	7/16	11.464 25.25
5	1 1/2, 1 9/16, 1 5/8, 1 11/16, 1 3/4, 1 13/16, 1 7/8, 1 15/16	254.0 10	139.7 5 1/2	530.2 20 7/8	581.0 22 7/8	19.0 3/4	82.6 3 1/4	171.4 6 3/4	50.8 2	88.9 3 1/2	—	1/2	20.203 44.50
7	2, 2 1/16, 2 1/8, 2 3/16, 2 1/4, 2 5/16, 2 3/8, 2 7/16	304.8 12	168.3 6 5/8	644.5 25 3/8	708.0 27 7/8	22.2 7/8	101.6 4	211.9 8 11/32	63.5 2 1/2	101.6 4	—	5/8	36.320 80.00
9	2 11/16, 2 15/16 ⁽¹⁾	304.8 12	193.7 7 5/8	695.3 27 3/8	771.5 30 3/8	25.4 1	117.5 4 5/8	243.7 9 19/32	82.6 3 1/4	120.6 4 3/4	65.1 2 9/16	5/8	52.778 116.25

⁽¹⁾Dimension K is 69.1 mm (2 23/32 in.) for 2 15/16 in. shaft diameters.

RTU INDUSTRIAL SERIES

- These ball bearing take-up units are used where shaft adjustment and belt-tightening devices are required, such as in conveyor applications.
- Both types of take-up units incorporate self-aligning, B-type wide-inner-ring ball bearings with self-locking collars.
- These units use a G-KRRB, R-seal type wide inner ring ball bearing.
- These units provide compact, efficient supports for adjustable shafts and conveyor take-up pulleys.
- The units are factory-prelubricated. A grease fitting is provided for relubrication if required.
- See the preceding page for take-up frames to fit these units.
- Contact your Timken engineer to discuss highly corrosive applications (e.g., food processing, chemical exposure) where Timken thin-dense chrome-coated bearings can be utilized.

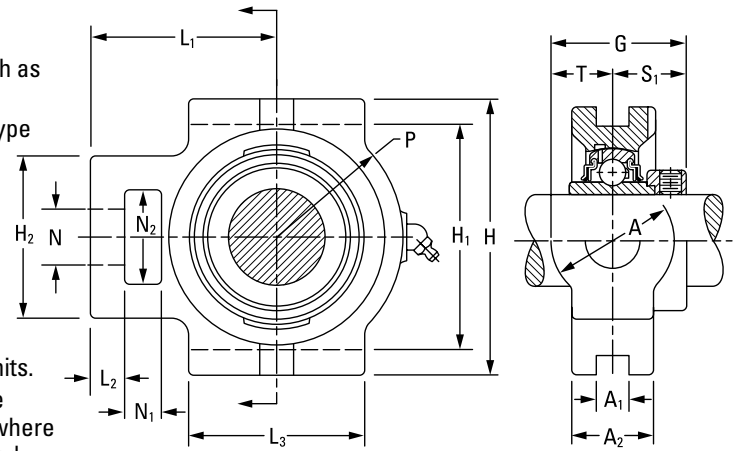

Suggested shaft tolerances:

- 3/4 in. – 1 15/16 in., nominal to -0.013 mm, -0.0005 in.;
- 2 in. – 2 7/16 in., nominal to -0.025 mm, -0.0010 in.

To order, specify UNIT and SHAFT DIAMETER.

Example: RTU 3/4 in. or RTU 2 11/16 in.

BEARING DATA

Unit	Bearing No.	Dimensions and Load Ratings
RTU	G-KRRB	Page 36

Unit	Shaft Dia.	G	T	S ₁	A ₂	A ₁	A	L ₁	H ₂	N	N ₂	L ₂	N ₁	P	L ₃	H ₁	H	Bearing No.	Collar No.	Housing No. New (Old)	Unit Wt. kg lbs.
		in. mm	in. mm	in. mm	in. mm	in. mm	in. mm	in. mm	in. mm	in. mm	in. mm	in. mm	in. mm	in. mm	in. mm	in. mm	in. mm				
RTU	3/4	47.6	20.6	27.0	34.1	13.5	41.3	67.5	57.2	19.0	31.8	12.7	15.9	49.2	57.2	76.2	92.1	G1012KRRB	S1012K	Z956572 (T18832)	1.444
RTU	20	1 7/8	1 3/16	1 1/16	1 11/32	1 7/32	1 5/8	2 21/32	2 1/4	3/4	1 1/4	1/2	5/8	1 15/16	2 1/4	3	3 5/8	GE20KRRB	SE20K		3.18
RTU	7/8	42.9	22.2	27.0	37.3	13.5	44.4	67.5	57.2	19.0	31.8	12.7	15.9	34.9	57.2	76.2	92.1	G1014KRRB	S1014K		1.498
RTU	1 5/16	1 15/16	7/8	1 1/16	1 15/32	1 7/32	1 3/4	2 21/32	2 1/4	3/4	1 1/4	1/2	5/8	1 3/8	2 1/4	3	3 5/8	G1015KRRB	S1015K	Z956394 (T18696)	1.498
RTU	1	1 15/16	7/8	1 1/16	1 15/32	1 7/32	1 3/4	2 21/32	2 1/4	3/4	1 1/4	1/2	5/8	1 3/8	2 1/4	3	3 5/8	G1100KRRB	S1100K		3.30
RTU	25																	GE25KRRB	SE25K		
RTU	1 1/16																	G1101KRRB	S1101K		
RTU	1 1/8	55.6	25.4	30.2	38.1	13.5	50.8	72.2	61.9	22.2	36.5	12.7	15.9	41.3	63.5	88.9	104.8	G1102KRRB	S1102K	Z955310 (T18694)	1.920
RTU	1 3/16	2 3/16	1	1 3/16	1 1/2	1 7/32	2	2 21/32	2 7/16	7/8	1 7/16	1/2	5/8	1 5/8	2 1/2	3 1/2	4 1/8	G1103KRRB	S1103K		4.23
RTU	30																	GE30KRRB	SE30K		
RTU	1 1/4																	G1104KRRB	S1104K		
RTU	1 5/16	54.8	22.2	32.5	36.5	13.5	44.5	74.6	63.5	22.2	36.5	12.7	15.9	49.2	69.8	88.9	104.8	G1105KRRB	S1105K	Z955315 (T18692)	2.025
RTU	1 3/8	2 5/32	7/8	1 9/32	1 7/16	1 7/32	1 3/4	2 15/16	2 1/2	7/8	1 7/16	1/2	5/8	1 15/16	2 3/4	3 1/2	4 1/8	G1106KRRB	S1106K		4.46
RTU	1 7/16																	G1107KRRB	S1107K		
RTU	35																	GE35KRRB	SE35K		
RTU	1 1/2	67.5	32.5	34.9	44.4	17.5	65.1	88.1	82.6	28.6	49.2	15.9	19.0	53.3	82.6	100.8	120.6	G1108KRRB	S1108KT	Z955350 (T18834)	3.314
RTU	1 9/16	2 21/32	1 9/32	1 3/8	1 3/4	1 11/16	2 9/16	3 15/32	3 1/4	1 1/8	1 15/16	5/8	3/4	2 3/32	3 1/4	3 31/32	4 3/4	G1109KRRB	S1109K		7.30
RTU	40																	GE40KRRB	SE40K		
RTU	1 5/8																	G1110KRRB	S1110K		
RTU	1 11/16	67.5	32.5	34.9	44.4	17.5	65.1	88.1	82.6	28.6	49.2	15.9	19.0	53.3	82.6	100.8	120.6	G1111KRRB	S1111K	Z956410 (T18762)	3.164
RTU	1 3/4	2 21/32	1 9/32	1 3/8	1 3/4	1 11/16	2 9/16	3 15/32	3 1/4	1 1/8	1 15/16	5/8	3/4	2 3/32	3 1/4	3 31/32	4 3/4	G1112KRRB	S1112K		6.97
RTU	45																	GE45KRRB	SE45K		
RTU	1 7/8	70.6	32.5	38.1	49.2	17.5	65.1	91.3	82.6	28.6	49.2	15.9	19.0	59.5	85.7	100.8	120.6	G1114KRRB	S1114K	Z955337 (T18690)	3.587
RTU	1 15/16	2 25/32	1 9/32	1 1/2	1 15/16	1 11/16	2 9/16	3 19/32	3 1/4	1 1/8	1 15/16	5/8	3/4	2 11/32	3 3/8	3 31/32	4 3/4	G1115KRRB	S1115K		7.90
RTU	50																	GE50KRRB	SE50K		
RTU	2																	G1200KRRB	S1201K		
RTU	2 1/8	77.0	34.9	43.7	55.6	27.0	69.8	119.9	101.6	34.9	63.5	19.0	31.8	69.1	101.6	129.4	149.2	G1202KRRB	S1202K	Z956469 (T18828)	6.333
RTU	2 3/16	3 1/32	1 3/8	1 23/32	2 3/16	1 1/16	2 3/4	4 23/32	4	1 3/8	2 1/2	3/4	1 1/4	2 23/32	4	5 3/32	5 7/8	G1203KRRB	S1203K		13.95
RTU	55																	GE55KRRB	SE55K		
RTU	2 1/4																	G1204KRRB	S1204K		
RTU	2 3/8	81.8	34.9	46.8	52.4	27.0	69.8	119.9	101.6	34.9	63.5	19.0	31.8	69.1	101.6	129.4	149.2	G1206KRRB	S1206K	Z955311 (T18830)	5.993
RTU	2 7/16	3 7/32	1 3/8	1 27/32	2 1/16	1 1/16	2 3/4	4 23/32	4	1 3/8	2 1/2	3/4	1 1/4	2 23/32	4	5 3/32	5 7/8	G1207KRRB	S1207K		13.20
RTU	60																	GE60KRRB	SE60K		

YTU INDUSTRIAL SERIES

- Used where shaft adjustment and belt tightening devices are required, such as conveyor applications.
- Incorporates self-aligning, B-type extra wide-inner-ring ball bearings with set screw lock.
- Provides compact, efficient supports for adjustable shafts and conveyor take-up pulleys.
- Factory-prelubricated. A grease fitting is provided for relubrication if required.
- Premium Shaft Guarding Technology™ option reduces replacement time, provides shaft protection and prolongs the life of the shaft.
- Safety end caps are available for selected sizes.
- See preceding pages for take-up frames to fit these units.
- Contact your Timken engineer to discuss highly corrosive applications (e.g., food processing, chemical exposure) where Timken thin-dense chrome-coated bearings can be utilized.

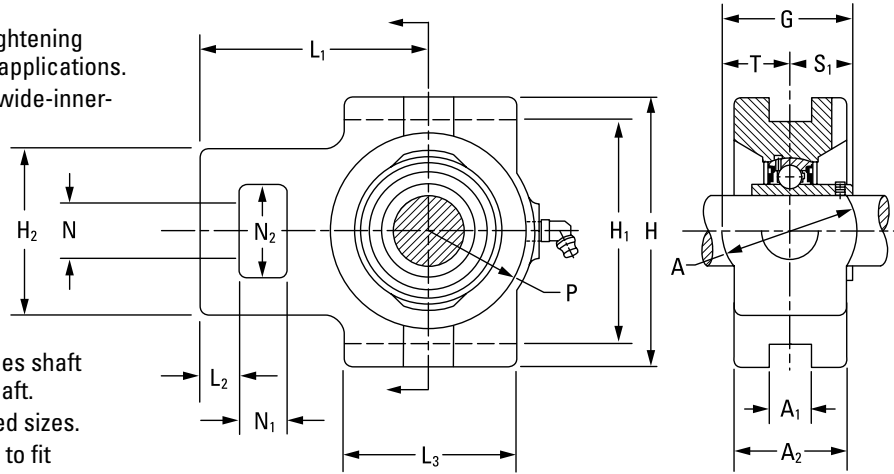

To order bearing with Shaft Guarding Technology™, specify bearing number followed by “SGT”.

Example: YTU 1 1/2 SGT

BEARING DATA

Unit	Bearing No.	Dimensions and Load Ratings
YTU	GY-KRRB	Page 46

Suggested shaft tolerances:

1/2 in. – 1 15/16 in., nominal to -0.013 mm, -0.0005 in.;
 2 in. – 2 15/16 in., nominal to -0.025 mm, -0.0010 in.

Unit	Shaft Dia.	G	T	S ₁	A ₂	A ₁	A	L ₁	H ₂	N	N ₂	L ₂	N ₁	P	L ₃	H ₁	H	Bearing No.	Housing No.	Unit Wt.
	in. mm	mm in.	mm in.	mm in.	mm in.	mm in.	mm in.	mm in.	mm in.	mm in.	mm in.	mm in.	mm in.	mm in.	mm in.	mm in.	mm in.			kg lbs.
YTU ⁽¹⁾	3/4	38.9 ⁽²⁾	20.6	18.3 ⁽²⁾	34.1	13.5	41.3	67.5	57.2	19.0	31.8	12.7	15.9	33.3	57.2	76.2	92.1	GY1012KRRB ⁽¹⁾	TU 47MM	1.338 2.950
YTU ⁽¹⁾	20	1 17/32	13/16	23/32	1 11/32	17/32	1 5/8	2 21/32	2 1/4	3/4	1 1/4	1/2	5/8	1 5/16	2 1/4	3	3 5/8	GYE20KRRB ⁽¹⁾		
YTU ⁽¹⁾	7/8	42.1 ⁽²⁾	22.2	19.9 ⁽²⁾	37.3	13.5	44.4	67.5	57.2	19.0	31.8	12.7	15.9	34.9	57.2	76.2	92.1	GY1014KRRB ⁽¹⁾	TU 52MM	1.390 3.064
YTU ⁽¹⁾	15/16																	1 21/32		
YTU ⁽¹⁾	1	47.6 ⁽³⁾	25.4	22.2 ⁽³⁾	38.1	13.5	50.8	72.2	61.9	22.2	36.5	12.7	15.9	41.3	63.5	88.9	104.8	GY1100KRRB ⁽¹⁾	TU 62MM	1.722 3.798
YTU ⁽¹⁾	25																	1 17/32		
YTU ⁽¹⁾	1 1/8	47.6 ⁽³⁾	22.2	25.4 ⁽⁴⁾	36.5	13.5	44.5	74.6	63.5	22.2	36.5	12.7	15.9	49.2	69.8	88.9	104.8	GY1102KRRB ⁽¹⁾	TU 72MM	1.752 3.863
YTU ⁽¹⁾	1 3/16																	1 7/8		
YTU ⁽¹⁾	1 1/4	62.7	32.5	30.2	44.4	17.5	65.1	88.1	82.6	28.6	49.2	15.9	19.0	53.3	82.6	100.8	120.6	GY1104KRRB ⁽¹⁾	TU 80MM	3.553 7.835
YTU ⁽¹⁾	1 3/8																	1 7/8		
YTU ⁽¹⁾	1 1/2	62.7 ⁽⁵⁾	32.5	30.2 ⁽⁵⁾	44.4	17.5	65.1	88.1	82.6	28.6	49.2	15.9	19.0	53.3	82.6	100.8	120.6	GY1107KRRB ⁽¹⁾	TU 85MM	3.075 6.780
YTU ⁽¹⁾	1 5/8																	2 15/32		
YTU ⁽¹⁾	1 3/4	65.0	32.5	32.5	49.2	17.5	65.1	91.3	82.6	28.6	49.2	15.9	19.0	59.5	85.7	100.8	120.6	GY1108KRRB ⁽¹⁾	TU 90MM	3.429 7.560
YTU ⁽¹⁾	1 7/8																	2 15/32		
YTU ⁽¹⁾	1 15/16	68.3	34.9	33.30	55.6	27.0	69.8	119.9	101.6	34.9	63.5	19.0	31.8	69.1	101.6	129.4	152.4	GY1110KRRB ⁽¹⁾	TU 100MM	6.095 13.440
YTU ⁽¹⁾	2																	2 11/16		
YTU ⁽¹⁾	2 3/16	74.6	34.9	39.70	52.4	27.0	69.8	119.9	101.6	34.9	63.5	19.0	31.8	69.1	101.6	129.4	149.2	GY1111KRRB ⁽¹⁾	TU 110MM	5.469 12.060
YTU ⁽¹⁾	55																	2 15/16		
YTU ⁽¹⁾	2 1/4	74.6	34.9	39.70	52.4	27.0	69.8	119.9	101.6	34.9	63.5	19.0	31.8	69.1	101.6	129.4	149.2	GY1115KRRB ⁽¹⁾	TU 110MM	5.469 12.060
YTU ⁽¹⁾	60																	2 15/16		
YTU ⁽¹⁾	2 3/8	74.6	34.9	39.70	52.4	27.0	69.8	119.9	101.6	34.9	63.5	19.0	31.8	69.1	101.6	129.4	149.2	GY1200KRRB ⁽¹⁾	TU 110MM	5.469 12.060
YTU ⁽¹⁾	55																	2 11/16		
YTU ⁽¹⁾	2 1/2	74.6	34.9	39.70	52.4	27.0	69.8	119.9	101.6	34.9	63.5	19.0	31.8	69.1	101.6	129.4	149.2	GYE55KRRB ⁽¹⁾	TU 110MM	5.469 12.060
YTU ⁽¹⁾	60																	2 15/16		
YTU ⁽¹⁾	2 7/8	74.6	34.9	39.70	52.4	27.0	69.8	119.9	101.6	34.9	63.5	19.0	31.8	69.1	101.6	129.4	149.2	GY1207KRRB ⁽¹⁾	TU 110MM	5.469 12.060
YTU ⁽¹⁾	60																	2 15/16		

⁽¹⁾Shaft Guard Technology available
⁽²⁾Inner Ring with SGT is wider by 0.737mm [0.029 in.]
⁽³⁾Inner Ring with SGT is wider by 1.016mm [0.040 in.]
⁽⁴⁾Inner Ring with SGT is wider by 2.540mm [0.100 in.]
⁽⁵⁾Inner Ring with SGT is wider by 1.143mm [0.045 in.]

VTU STANDARD SERIES

- These units are used where shaft adjustment and belt-tightening devices are required (e.g., conveyor belt applications).
- This unit provides self-aligning, B-type wide-inner-ring ball bearings with self-locking collars.
- Provides compact, efficient supports for adjustable shafts and conveyor take-up pulleys.
- The units are factory-prelubricated. A grease fitting is provided for relubrication if required.
- See the preceding pages for take-up frames to fit these units.

Suggested shaft tolerances:

3/4 in. – 1 15/16 in., nominal to -0.013 mm, -0.0005 in.;
 2 in. – 2 3/16 in., nominal to -0.025 mm, -0.0010 in.

To order, specify UNIT and SHAFT DIAMETER.

Example: VTU 3/4 in. or VTU 2 11/16 in.

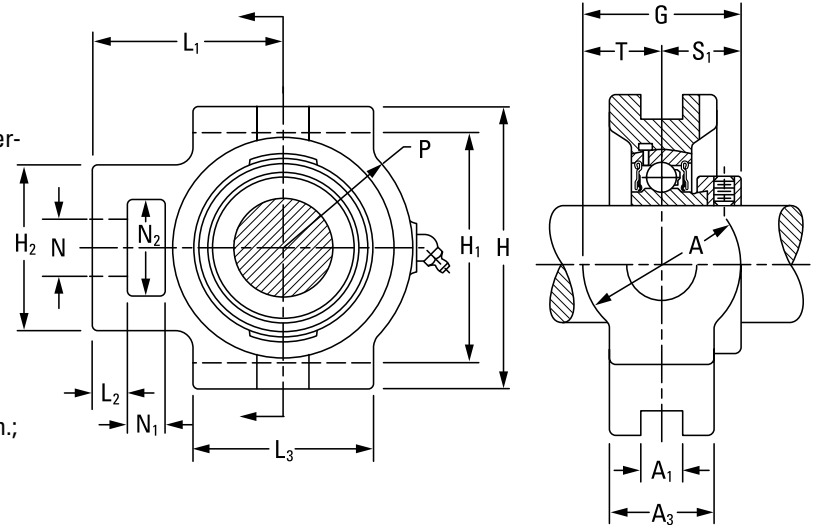

BEARING DATA

Unit	Bearing No.	Dimensions and Load Ratings
VTU	GRA-RRB	Page 52

Unit	Shaft Dia.	Dimensions																Bearing No.	Collar No.	Housing No. New (Old)	Unit Wt.
		G	T	S ₁	A ₃	A ₁	A	L ₁	H ₂	N	N ₂	L ₂	N ₁	P	L ₃	H ₁	H				
	in. mm	mm in.	mm in.	mm in.	mm in.	mm in.	mm in.	mm in.	mm in.	mm in.	mm in.	mm in.	mm in.	mm in.	mm in.	mm in.	mm in.				kg lbs.
VTU 3/4	20	44.1	20.6	23.4	34.1	13.5	41.3	67.5	57.2	19.0	31.8	12.7	15.9	33.3	57.2	76.2	92.1	GRA012RRB	S1012K	Z956572 (T18832)	1.372
VTU 7/8	25	45.2	22.2	23.0	37.3	13.5	44.4	67.5	57.2	19.0	31.8	12.7	15.9	34.9	57.2	76.2	92.1	GRA014RRB	S1014K	Z956394 (T18696)	1.458
VTU 1 1/8	30	52.0	25.4	27.0	38.1	13.5	50.8	72.2	61.9	22.2	36.5	12.7	15.9	41.3	63.5	88.9	104.8	GRA102RRB	S1102K	Z955310 (T18694)	1.862
VTU 1 1/4	35	51.6	22.2	29.4	36.5	13.5	44.5	74.6	63.5	22.2	36.5	12.7	15.9	49.2	69.8	88.9	104.8	GRA103RRB	S1103K3	Z955315 (T18692)	1.953
VTU 1 1/2	40	65.0	32.5	32.5	44.4	17.5	65.1	88.1	82.6	28.6	49.2	15.9	19.0	53.3	82.6	100.8	120.6	GRA104RRB	S1104K	T18834	3.192
VTU 1 5/8	45	65.0	32.5	32.5	44.4	17.5	65.1	88.1	82.6	28.6	49.2	15.9	19.0	53.3	82.6	100.8	120.6	GRA106RRB	S1106K	Z956410 (T18762)	3.009
VTU 1 7/8	50	65.0	32.5	32.5	49.2	17.5	65.1	91.3	82.6	28.6	49.2	15.9	19.0	59.5	85.7	100.8	120.6	GRA107RRB	S1107K	Z955337 (T18690)	3.342
VTU 2	55	71.4	34.9	36.5	55.6	27.0	69.8	119.9	101.6	34.9	63.5	19.0	31.8	69.1	101.6	129.4	149.2	GRAE25RRB	SE25K	Z956469 (T18828)	5.784
VTU 2 1/8	55	71.4	34.9	36.5	55.6	27.0	69.8	119.9	101.6	34.9	63.5	19.0	31.8	69.1	101.6	129.4	149.2	GRAE30RRB	SE30K		12.73
VTU 2 1/4	55	71.4	34.9	36.5	55.6	27.0	69.8	119.9	101.6	34.9	63.5	19.0	31.8	69.1	101.6	129.4	149.2	GRAE35RRB	SE35K		12.73

TTU INDUSTRIAL SERIES

- These units are used where shaft adjustment and belt-tightening devices are required (e.g., in conveyor belt applications).
- The unit incorporates self-aligning, B-type, extra wide-inner-ring ball bearings with self-locking collars.
- The unit uses a G-KPPB (tri-ply) type wide inner ring ball bearing.
- The unit provides compact, efficient supports for adjustable shafts and conveyor take-up pulleys.
- The units are factory-prelubricated. A grease fitting is provided for relubrication if required.
- Contact your Timken engineer to discuss highly corrosive applications (e.g., food processing, chemical exposure) where Timken thin-dense chrome-coated bearings can be utilized.

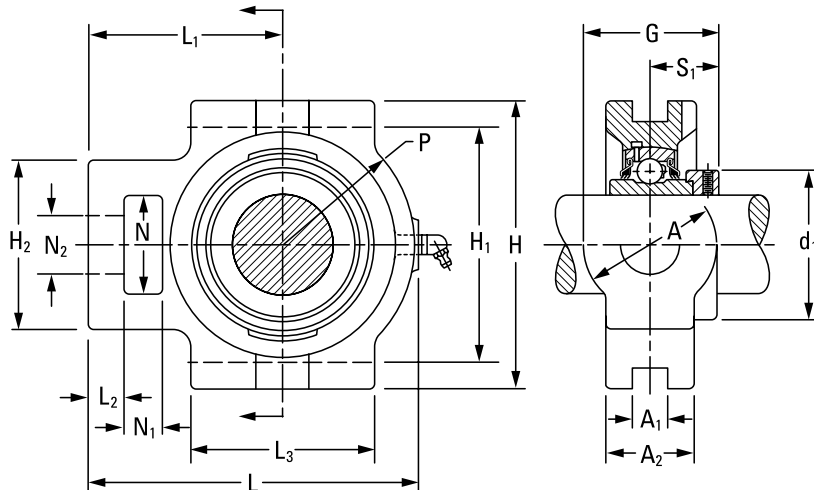

Suggested shaft tolerances:

2 in. – 2 3/16 in., nominal to -0.025 mm, -0.0010 in.

To order, specify UNIT and SHAFT DIAMETER.

Example: TTU 3/4 in.

BEARING DATA

Unit	Bearing No.	Dimensions and Load Ratings
TTU	G-KPPB	Page 41

Unit	Shaft Dia.	Dimensions																	Bearing No.	Housing No. New (Old)
		G	L	S ₁	d ₁	A ₂	A ₁	A	L ₁	H ₂	N	N ₂	L ₂	N ₁	P	L ₃	H ₁	H		
	in.	mm	mm	mm	mm	mm	mm	mm	mm	mm	mm	mm	mm	mm	mm	mm	mm	mm		
	mm	in.	in.	in.	in.	in.	in.	in.	in.	in.	in.	in.	in.	in.	in.	in.	in.	in.		
TTU	1 1/4																		G1104KPPB2	
	1 5/16	54.38	125.41	32.31	53.98	36.51	13.49	44.45	74.61	63.50	36.51	22.23	12.70	15.88	49.21	69.85	88.90	104.78	G1105KPPB2	Z955315
	1 3/8	2.141	4 15/16	1.272	2.125	1 7/16	17/32	1 3/4	2 15/16	2 1/2	1 7/16	0.875	1/2	5/8	1 15/16	2 3/4	3 1/2	4 1/8	G1106KPPB2	(T18692)
	1 7/16																		G1107KPPB2	
TTU	1 15/16	70.64	152.80	38.07	69.34	49.21	17.46	65.09	91.28	82.55	49.21	28.58	15.88	19.05	59.53	85.73	100.81	120.65	G1115KPPB3	Z955337
		2.781	6 1/64	1.499	2.73	1 15/16	11/16	2 9/16	3 19/32	3 1/4	1 15/16	1.125	5/8	3/4	2 11/32	3 3/8	3 31/32	4 3/4		(T18690)
TTU	2																		G1200KPPB4	
	2 1/16	79	190.5	43.6	75.7	55.6	27	69.8	119.9	101.6	63.5	34.7	19	31.8	69.1	101.6	129.4	149.2	G1201KPPB4	Z956469
	2 1/8	3.109	7 1/2	1.716	2.980	2 3/16	1 1/16	2 3/4	4 23/32	4	2 1/2	1.365	3/4	1 1/4	2 23/32	4	5 3/32	5 7/8	G1202KPPB4	(T18828)
	2 3/16																		G1203KPPB4	
	55																		GE55KPPB4	

**TIMKEN® FAFNIR® SURVIVOR®
PS SERIES**

Timken® Fafnir® Survivor® PS series mounted bearings have polymer housings and a 300-series stainless-steel insert to provide the highest possible corrosion resistance in the industry (fig. 24). The engineered polymer housing unit is FDA/USDA compliant. It is specifically designed for light loads and low speeds with stainless-steel set screws.

The durable corrosion-proof polymer housing features stainless-steel crush bushings in mounting holes with stainless-steel grease fittings with a nylon cap (table 23). It resists a broad range of acids and alkalis, as well as steam and continuous temperature up

to 121° C (250° F) and brief exposure up to 160° C (320° F). Additionally, the polymer strength exceeds the static capacity of the bearing, and the housing retains proper bearing fit and resists shock loads. The flush base has no voids where bacteria could collect. Optional end covers further protect the insert bearing from direct contact with wash-down solutions and cover rotating components.

Survivor PS series units are available as:

- High-base and low-base pillow blocks.
- Two-bolt and four-bolt flanged cartridges for popular shaft sizes.

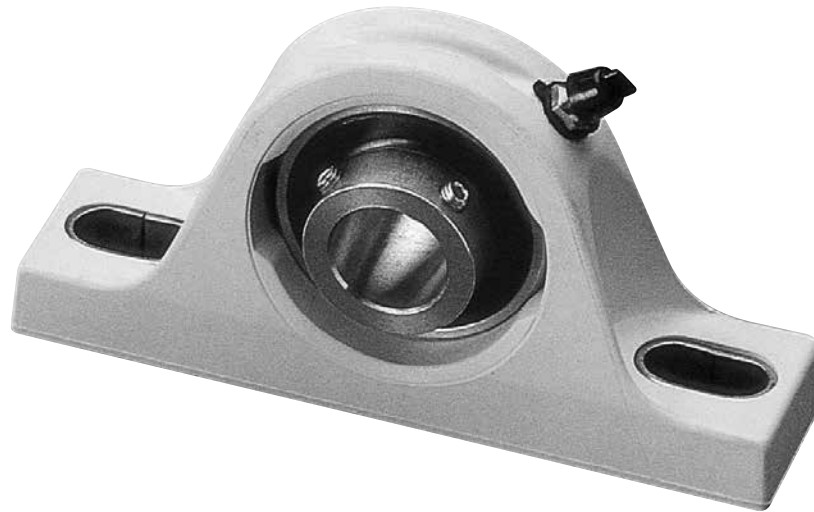

Fig. 24. PS series.

TABLE 23.

PS SERIES	
Component	Material
Balls	Stainless steel
Ball retainer	Nylon
Set screws	Stainless steel
Crush bushing	Stainless steel
Grease	FDA approved
Housing	Polymer
Grease fitting	Stainless steel
Grease-fitting cover	Nylon
Rings	Stainless steel
Seals	Synthetic rubber

ORDERING INFORMATION

To order complete Survivor polymer assemblies, simply replace the (current cast-iron mounted bearing designations) prefix with K and add the PS suffix.

Example: **KCJT 1 PS** or **KAK 3/4 PS**

PS Survivor inserts can be ordered using the part numbers shown in the following tables.

Example: **KCJT1PS100RRB** or **KAK3/4PS012RRB**

PS KAK/S SERIES

- The 300-series stainless-steel insert provides the highest resistance to corrosion in the industry.
- This unit is used for the ready-to-eat portion of the process. Loads are lighter and corrosion protection is the primary concern.
- Specifically designed for light loads and low speeds, and has stainless-steel set screws.
- The durable, corrosion-proof polymer housing has stainless-steel crush bushings in the mounting holes and a stainless-steel grease fitting with nylon cap.
- Polymer resists a broad range of acids and alkalis, as well as steam and continuous temperature up to 121° C (250° F) and brief exposure up to 160° C (320° F).
- The polymer strength exceeds static capacity of bearing; housing retains proper bearing fit and resists shock loads.
- The flush base contains no voids where bacteria can collect.
- The optional end covers further protect insert bearing from direct contact with washdown solutions and cover rotating components.

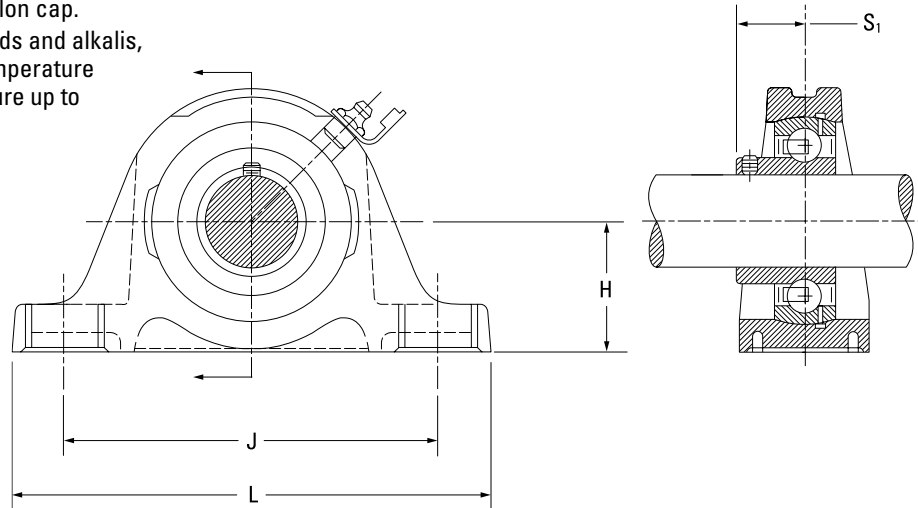

Unit ⁽¹⁾	Shaft Dia.	Type						Static Load Rating	Limiting Speed	Bearing No.
			KAK H	KAS H	J	L	S ₁			
	in. mm		mm in.	mm in.	mm in.	mm in.	mm in.	N lbs.	RPM	
KAK/S	3/4 20	PS	31.75 1 1/4	33.34 1 15/16	96.04 3 25/32	127.00 5	18.26 23/32	900 200	500	GKY012RRB GKYE20RRB
KAK/S	1 25	PS	33.34 1 5/16	36.51 1 7/16	104.78 4 1/8	139.70 5 1/2	20.64 13/16	1100 240	425	GKY100RRB GKYE25RRB
KAK/S	1 3/16 1 1/4 S 30	PS	39.69 1 9/16	42.86 1 11/16	117.48 4 5/8	157.16 6 3/16	22.23 7/8	1600 350	375	GKY103RRB GKY103RRB2 GKYE30RRB
KAK/S	1 1/4 1 7/16 35	PS	46.04 1 13/16	47.63 1 7/8	130.18 5 1/8	166.69 6 9/16	27.38 1 5/64	2100 475	300	GKY104RRB GKY107RRB GKYE35RRB

⁽¹⁾Option of low-base KAK or high-base KAS.

KCJ SERIES

- The 300-series stainless-steel insert provides the highest resistance to corrosion in the industry.
- This unit is used for the ready-to-eat portion of the process. Loads are lighter and corrosion protection is the primary concern.
- Specifically designed for light loads and low speeds, and has stainless-steel set screws.
- The durable, corrosion-proof polymer housing has stainless-steel crush bushings in the mounting holes and a stainless-steel grease fitting with nylon cap.
- Polymer resists a broad range of acids and alkalis, as well as steam and continuous temperature up to 121° C (250° F) and brief exposure up to 160° C (320° F).
- The polymer strength exceeds static capacity of bearing; housing retains proper bearing fit and resists shock loads.
- The flush base contains no voids where bacteria can collect.
- The optional end covers further protect insert bearing from direct contact with washdown solutions and cover rotating components.

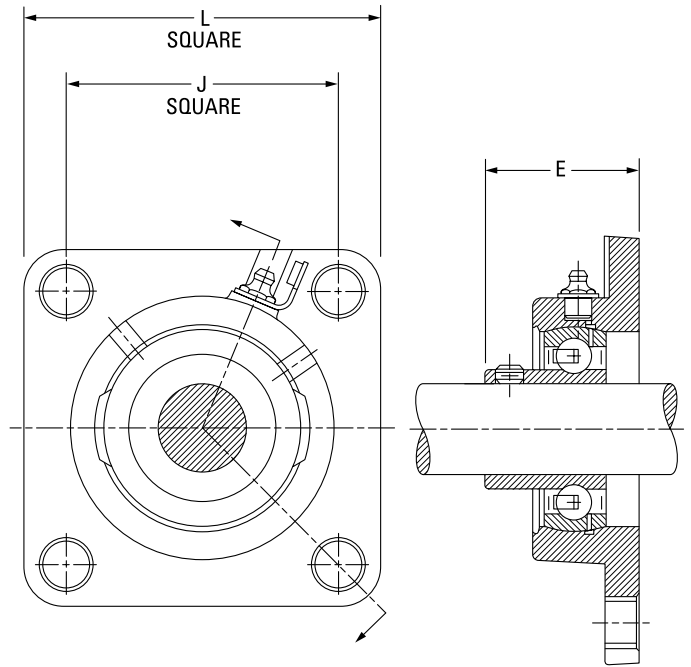

Unit	Shaft Dia.	Type	L		J		E		Static Load Rating	Limiting Speed	Bearing No.
			mm	in.	mm	in.	mm	in.			
KCJ	3/4	PS	85.33		63.50		37.31		900 200	500	GKY012RRB GKYE20RRB
	20										
KCJ	1	PS	94.85		69.85		39.69		1100 240	425	GKY100RRB GKYE25RRB
	25										
KCJ	1 3/16	PS	107.95		82.55		41.28		1600 350	375	GKY103RRB GKY103RRB2 GKYE30RRB
	1 1/4 S 30										
KCJ	1 1/4	PS	117.48		92.08		46.04		2100 475	300	GKY104RRB GKY107RRB GKYE35RRB
	1 7/16 35										

KCJT AND KTB SERIES

- The 300-series stainless-steel insert provides the highest resistance to corrosion in the industry.
- This unit is used for the ready-to-eat portion of the process. Loads are lighter and corrosion protection is the primary concern.
- Specifically designed for light loads and low speeds, and has stainless-steel set screws.
- The durable, corrosion-proof polymer housing has stainless-steel crush bushings in the mounting holes and a stainless-steel grease fitting with nylon cap.
- Polymer resists a broad range of acids and alkalis, as well as steam and continuous temperature up to 121° C (250° F) and brief exposure up to 160° C (320° F).
- The polymer strength exceeds static capacity of bearing; housing retains proper bearing fit and resists shock loads.
- The flush base contains no voids where bacteria can collect.
- The optional end covers further protect insert bearing from direct contact with washdown solutions and cover rotating components.

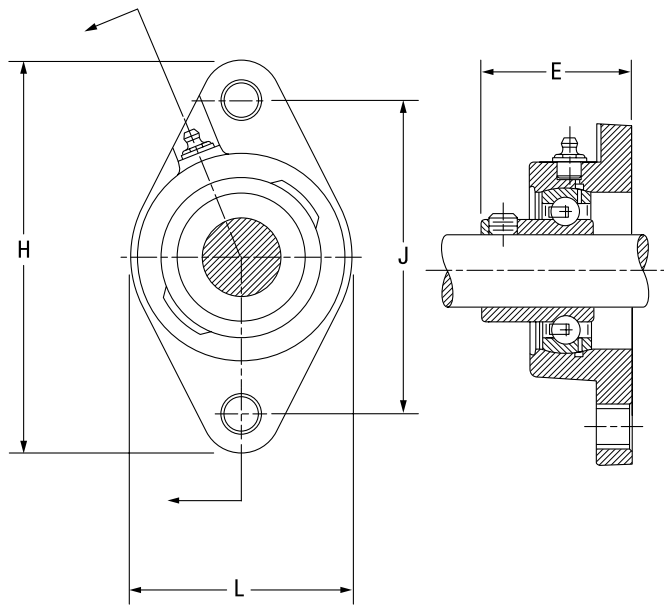

Unit	Shaft Dia.	Type	H	J	L	E	Static Load Rating	Limiting Speed	Bearing No.
	in. mm		mm in.	mm in.	mm in.	mm in.	N lbs.	RPM	
KCJT	3/4 20	PS	111.92 4 13/32	89.69 3 17/32	60.33 2 3/8	37.31 1 15/32	900 200	500	GKY012RRB GKYE20RRB
KCJT	1 25	PS	124.22 4 57/64	98.82 3 57/64	65.48 2 37/64	39.69 1 9/16	1100 240	425	GKY100RRB GKYE25RRB
KCJT	1 3/16 1 1/4 S 30	PS	140.89 5 35/64	116.68 4 19/32	76.20 3	41.28 1 5/8	1600 350	375	GKY103RRB GKY103RRB2 GKYE30RRB
KCJT	1 1/4 1 7/16 35	PS	155.58 6 1/8	130.18 5 1/8	92.08 3 5/8	49.21 1 15/16	2100 475	300	GKY104RRB GKY107RRB GKYE35RRB

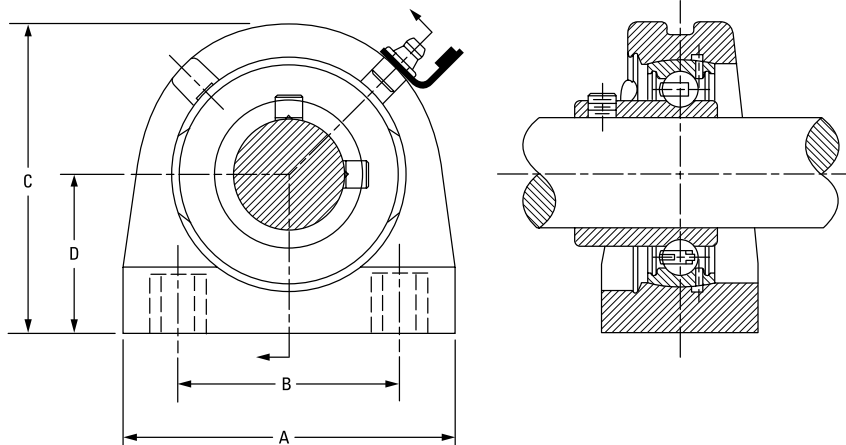

Unit	Shaft Dia.	Type	A	B	C	D	Static Load Rating	Limiting Speed	Bearing No.
	in. mm		mm in.	mm in.	mm in.	mm in.	N lbs.	RPM	
KTB	1	PS	76.20 3	50.80 2	71.44 2 13/16	36.51 1 7/16	1100 240	425	GKY100RRB

TIMKEN® FAFNIR® SURVIVOR® PT SERIES

Timken® Fafnir® Survivor® PT series mounted bearings are designed to meet stringent food-handling requirements while standing up to highly corrosive environments (fig. 25). All materials used in Survivor assemblies, including grease, are approved for USDA- and FDA-compliant industries (table 24).

The Survivor series also provides extraordinary corrosion resistance for materials handling operations, dairy and refrigeration applications, as well as heating, ventilation and air conditioning (HVAC), chemical, maritime and other highly corrosive environments.

Patented Survivor PT polymer mounted bearings withstand a wide range of chemicals. These units are dimensionally stable under load and able to operate in continuous temperatures up to 120° C (250° F) and brief exposures up to 177° C (350° F).

Our bearing inserts are coated in proprietary Timken thin-dense chrome that will not crack or peel. Inserts are available with a self-locking collar or a set screw locking device. Also available is Timken Shaft Guarding Technology (page 33), which uses a stainless-steel, hardened band to transfer gripping pressure on the shaft. Unlike traditional set screws, which can dig into the

shaft, there are no nicks, raised metal or permanent shaft damage. The stainless band won't corrode on the shaft. Mounted bearings with Shaft Guarding Technology also reduce change-out time.

Survivor PT series units are available as:

- High-base and low-base pillow blocks.
- Two-bolt and four-bolt flanged cartridges for popular shaft sizes of ½ in. through 2 15/16 in. (and selected metric diameters).
- Take-up unit in the Survivor PT series in limited shaft sizes (RTU-NT). The bearing inserts are available with self-locking collars.

Timken also produces a take-up unit in the Survivor NT series in limited shaft sizes (RTU-NT). The bearing inserts are available with self-locking collars.

Survivor PT assemblies are dimensionally interchangeable with the current line of Timken Fafnir cast-iron mounted bearings.

The polymer housing and TDC coating resist premature failure under corrosive conditions. These properties extend the life of the mounted bearing. Longer periods between replacements save costs and reduce downtime.



Fig. 25. Popular styles.

TABLE 24.

PT SERIES	
Component	Material
Balls	Stainless steel
Ball retainer	Nylon
Collar	Stainless steel
Crush bushing	Stainless steel
Grease	FDA approved
Housing	Polymer
Grease fitting	Stainless steel
Grease fitting cover	Nylon
Rings	TDC plated
Seals	Synthetic rubber
Seal caps	Stainless steel
Set screw	Stainless steel

ORDERING INFORMATION

To order complete Survivor polymer assemblies, simply add the PT suffix to the current cast-iron mounted bearing designations.

Example: YCJT 1 PT SGT or RAK ¾ PT SGT

Survivor inserts can be ordered using Timken's standard part number for wide-inner-ring ball bearings with a TDCF suffix.

Example: GY1100KRRB TDCF SGT or G1100KRRB + COL TDCF SGT

PT YAK/S SERIES

- This unit is used for the main portion of the process where loads are lighter and corrosion protection is important.
- Durable corrosion-proof polymer housing with stainless-steel crush bushings in mounting holes and a stainless-steel grease fitting with a nylon cap.
- Polymer resists a broad range of acids and alkalis, as well as steam and continuous temperature up to 121° C (250° F), and brief exposure up to 160° C (320° F).
- The polymer strength exceeds static capacity of bearing; housing retains proper bearing fit and resists shock loads.
- The flush base contains no voids where bacteria can collect.
- Corrosion-resistant insert bearing with stainless-steel balls and a nylon retainer. The PT series also features industrial-duty contact seals with stainless-steel shroud caps.
- This unit has stainless-steel set screws with Shaft Guarding Technology.
- This unit is factory lubricated with FDA/USDA-approved grease (class H1 lubricant) for incidental food contact.

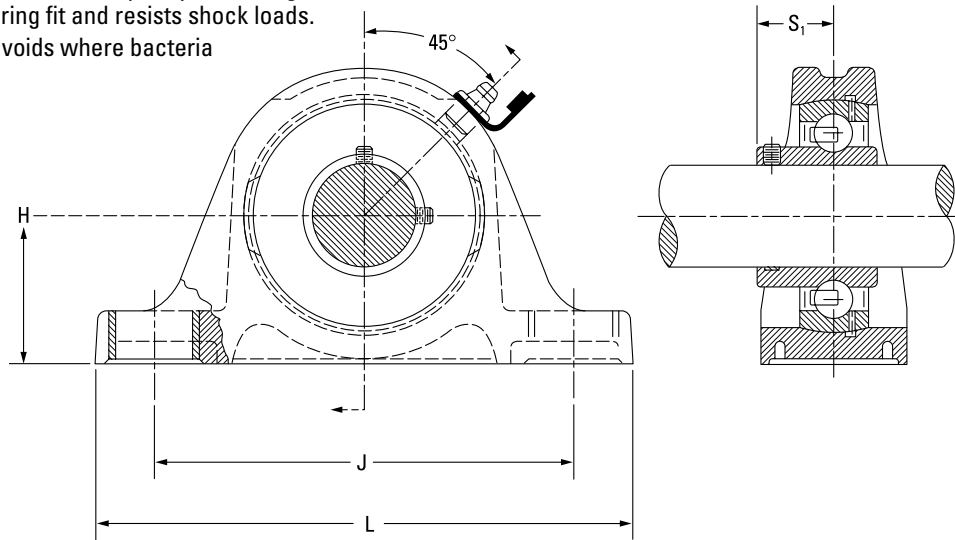

Unit ⁽¹⁾	Shaft Dia.	Type	Dimensions					Static Load Rating	Dynamic Load Rating	Speed Rating	Bearing No.	
			YAK H	YAS H	J	L	S ₁					
	in. mm		mm in.	mm in.	mm in.	mm in.	mm in.	N lbs.	N lbs.	RPM		
YAK/S	3/4	PT SGT	31.75	33.34	96.04	127.00	19.05	6500 1460	14500 3250	9200 8800	GY1012KRRB	TDCF SGT
	20		1 1/4 1 5/16	3 25/32 5	3/4	GYE20KRRB	TDCF SGT					
YAK/S	1	PT SGT	33.34	36.51	104.78	139.70	20.64	7700 1730	15800 3550	6900 7000	GY1100KRRB	TDCF SGT
	25		1 5/16 1 7/16	4 1/8 5 1/2	13/16	GYE25KRRB	TDCF SGT					
YAK/S	1 1/4	PT PT SGT	39.69	42.86	117.48	157.16	23.4	11100 2500	21800 4900	5500 5800	GY1103KRRB3	TDCF
	30		1 9/16 1 11/16	4 5/8 6 3/16	59/64	GYE30KRRB	TDCF SGT					
YAK/S	1 3/8	PT SGT	46.04 1 13/16	47.63 1 7/8	130.18 5 1/8	166.69 6 9/16	28.18 1 7/64	15100 3400	28500 6400	5000	GY1106KRRB	TDCF SGT
	1 7/16									4800	GY1107KRRB	TDCF SGT
	35									5000	GYE35KRRB	TDCF SGT
YAK/S	1 1/2	PT SGT	49.21 1 15/16	49.21 1 15/16	136.53 5 3/8	179.39 7 1/16	30.16 1 3/16	19600 4400	36300 8150	4600	GY1108KRRB	TDCF SGT
	40									4400	GYE40KRRB	TDCF SGT

⁽¹⁾Option of low-base RAK or high-base RAS.

YCJ SERIES

- This unit is used for the main portion of the process where loads are lighter and corrosion protection is important.
- Durable corrosion-proof polymer housing with stainless-steel crush bushings in mounting holes and a stainless-steel grease fitting with a nylon cap.
- Polymer resists a broad range of acids and alkalis, as well as steam and continuous temperature up to 121° C (250° F), and brief exposure up to 160° C (320° F).
- The polymer strength exceeds static capacity of bearing; housing retains proper bearing fit and resists shock loads.
- The flush base contains no voids where bacteria can collect.
- Corrosion-resistant insert bearing with stainless-steel balls and a nylon retainer. The PT series also features industrial-duty contact seals with stainless-steel shroud caps.
- This unit has stainless-steel set screws with Shaft Guarding Technology.
- This unit is factory lubricated with FDA/USDA-approved grease (class H1 lubricant) for incidental food contact.

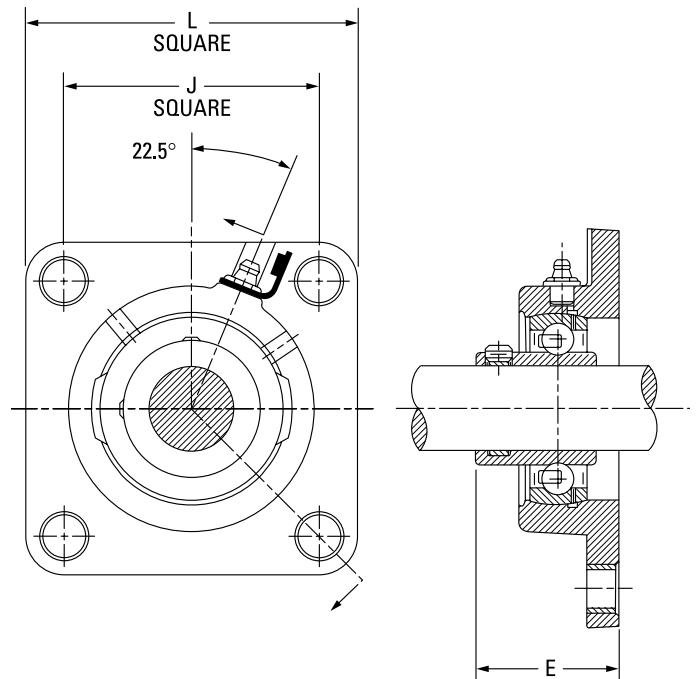

Unit	Shaft Dia.	Type				Static Load Rating	Dynamic Load Rating	Speed Rating	Bearing No.	
			L	J	E					
	in. mm		mm in.	mm in.	mm in.	N lbs.	N lbs.	RPM		
YCJ	3/4 20	PT SGT	85.73	63.50	38.10	6500	14500	9200	GY1012KRRB	TDCF SGT
			3 3/8	2 1/2	1 1/2	1460	3250	8800	GYE20KRRB	TDCF SGT
YCJ	1 25	PT SGT	95.25	69.85	39.69	7700	15800	6900	GY1100KRRB	TDCF SGT
			3 3/4	2 49/64	1 9/16	1730	3550	7000	GYE25KRRB	TDCF SGT
YCJ	1 3/16 1 1/4S 30	PT SGT	107.95	82.55	42.07	11100	21800	5800	GY1103KRRB	TDCF SGT
		PT						5500	GY1103KRRB3	TDCF
		PT SGT						5800	GYE30KRRB	TDCF SGT
YCJ	1 1/4 1 3/8 1 7/16 35	PT SGT	117.48	92.08	48.42	15100	28500	5500	GY1104KRRB	TDCF SGT
								5000	GY1106KRRB	TDCF SGT
								4800	GY1107KRRB	TDCF SGT
								5000	GYE35KRRB	TDCF SGT
YCJ	1 1/2 40	PT SGT	130.18	101.60	53.98	19600	36300	4600	GY1108KRRB	TDCF SGT
								4400	GYE40KRRB	TDCF SGT

YCJT SERIES

- This unit is used for the main portion of the process where loads are lighter and corrosion protection is important.
- Durable corrosion-proof polymer housing with stainless-steel crush bushings in mounting holes and a stainless-steel grease fitting with a nylon cap.
- Polymer resists a broad range of acids and alkalis, as well as steam and continuous temperature up to 121° C (250° F), and brief exposure up to 160° C (320° F).
- The polymer strength exceeds static capacity of bearing; housing retains proper bearing fit and resists shock loads.
- The flush base contains no voids where bacteria can collect.
- Corrosion-resistant insert bearing with stainless-steel balls and a nylon retainer. The PT series also features industrial-duty contact seals with stainless-steel shroud caps.
- This unit has stainless-steel set screws with Shaft Guarding Technology.
- This unit is factory lubricated with FDA/USDA-approved grease (class H1 lubricant) for incidental food contact.

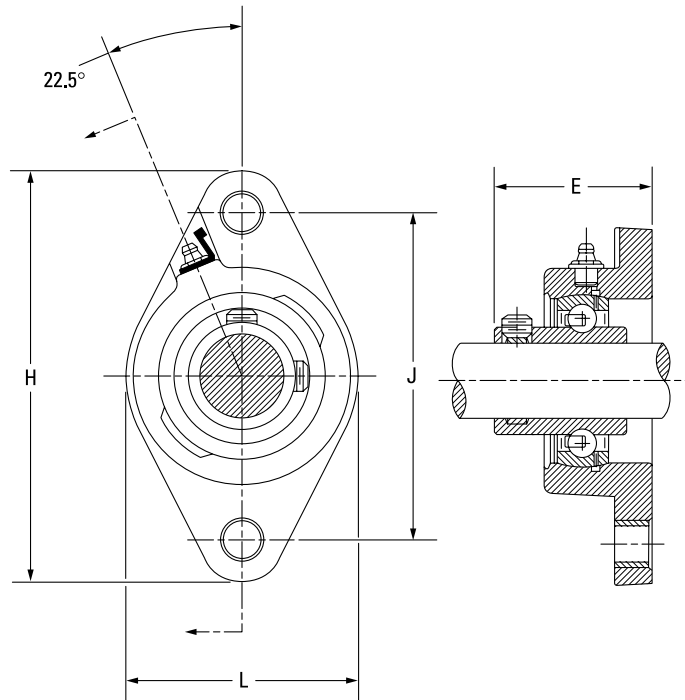

Unit	Shaft Dia.	Type	Dimensions				Static Load Rating	Dynamic Load Rating	Speed Rating	Bearing No.	
			H	J	L	E					
	in. mm		mm in.	mm in.	mm in.	mm in.	N lbs.	N lbs.	RPM		
YCJT	3/4 20	PT SGT	111.92	89.69	60.33	38.10	6500	14500	9200	GY1012KRRB	TDCF SGT
			4 13/32	3 17/32	2 3/8	1 1/2	1460	3250	8800	GYE20KRRB	TDCF SGT
YCJT	1 25	PT SGT	123.83	99.22	69.85	39.69	7700	15800	6900	GY1100KRRB	TDCF SGT
			4 7/8	3 29/32	2 3/4	1 9/16	1730	3550	7000	GYE25KRRB	TDCF SGT
YCJT	1 3/16 1 1/4S 30	PT SGT	141.29	116.68	79.38	42.07	11100	21800	5800	GY1103KRRB	TDCF SGT
		PT							5500	GY1103KRRB3	TDCF
		PT SGT							5800	GYE30KRRB	TDCF SGT
YCJT	1 1/4 1 3/8 1 7/16 35	PT SGT	155.58	130.18	92.08	48.42	15100	28500	5500	GY1104KRRB	TDCF SGT
									5000	GY1106KRRB	TDCF SGT
									4800	GY1107KRRB	TDCF SGT
									5000	GYE35KRRB	TDCF SGT
YCJT	1 1/2 40	PT SGT	171.45	143.67	104.78	53.98	19600	36300	4600	GY1108KRRB	TDCF SGT
									4400	GYE40KRRB	TDCF SGT

YTB AND YFB SERIES

- This unit is used for the main portion of the process where loads are lighter and corrosion protection is important.
- Durable corrosion-proof polymer housing with stainless-steel crush bushings in mounting holes and a stainless-steel grease fitting with a nylon cap.
- Polymer resists a broad range of acids and alkalis, as well as steam and continuous temperature up to 121° C (250° F), and brief exposure up to 160° C (320° F).
- The polymer strength exceeds static capacity of bearing; housing retains proper bearing fit and resists shock loads.
- The flush base contains no voids where bacteria can collect.
- Corrosion-resistant insert bearing with stainless-steel balls and a nylon retainer. The PT series also features industrial-duty contact seals with stainless-steel shroud caps.

- This unit has stainless-steel set screws with Shaft Guarding Technology.
- This unit is factory lubricated with FDA/USDA-approved grease (class H1 lubricant) for incidental food contact.

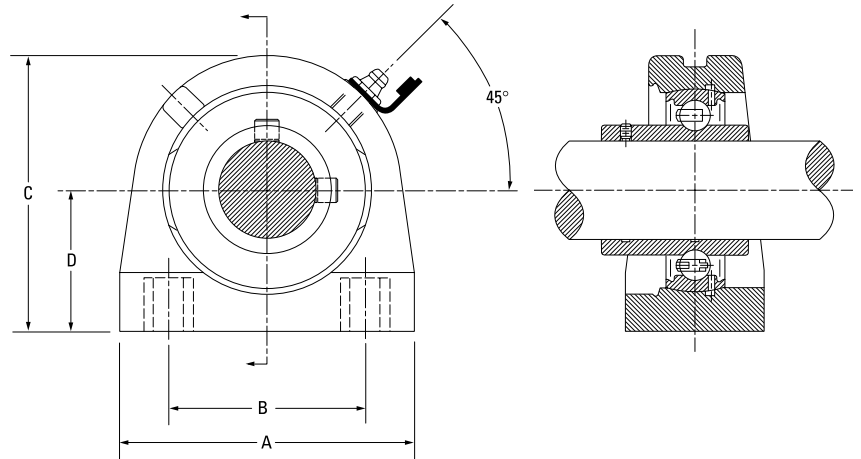

Unit	Shaft Dia.	Type	A	B	C	D	Static Load Rating	Dynamic Load Rating	Speed Rating	Bearing No.	
	in. mm		mm in.	mm in.	mm in.	mm in.	N lbs.	N lbs.	RPM		
YTB	1 25	PT SGT	76.20 3	50.80 2	71.44 2 13/16	36.51 1 7/16	7700 1730	15800 3550	6900 7000	GY1100KRRB GYE25KRRB	TDCF SGT TDCF SGT

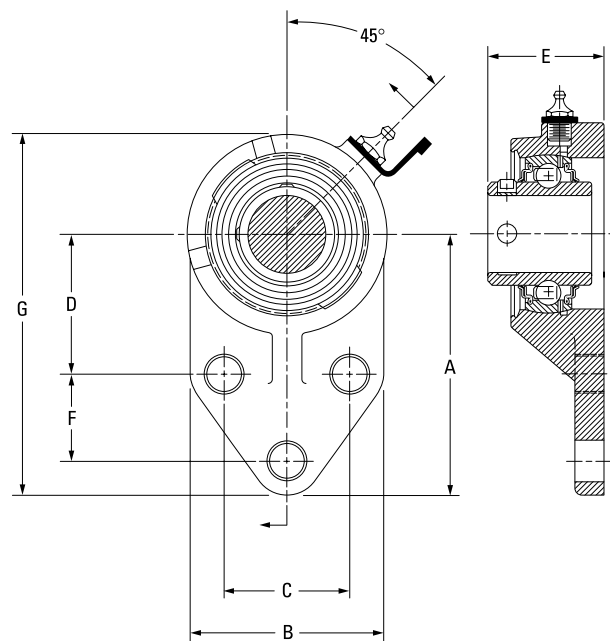

Unit	Shaft Dia.	Type	A	B	C	D	E	F	G	Static Load Rating	Dynamic Load Rating	Speed Rating	Bearing No.	
	in. mm		mm in.	mm in.	mm in.	mm in.	mm in.	mm in.	mm in.	N lbs.	N lbs.	RPM		
YFB	1 25	PT SGT	85.73 3 3/8	63.50 2 1/2	41.28 1 5/8	46.04 1 13/16	38.10 1 1/2	28.58 1 1/8	118.66 4 43/64	6900 1560	15300 3450	6900 7000	GY1100KRRB GYE25KRRB	TDCF SGT TDCF SGT

RAK/S SERIES

- This unit is used for the main portion of the process where loads are lighter and corrosion protection is important.
- Durable corrosion-proof polymer housing with stainless-steel crush bushings in mounting holes and a stainless-steel grease fitting with a nylon cap.
- Polymer resists a broad range of acids and alkalis, as well as steam and continuous temperature up to 121° C (250° F), and brief exposure up to 160° C (320° F).
- The polymer strength exceeds static capacity of bearing; housing retains proper bearing fit and resists shock loads.
- The flush base contains no voids where bacteria can collect.

- Corrosion-resistant insert bearing with stainless-steel balls and a nylon retainer. The PT series also features industrial-duty contact seals with stainless-steel shroud caps.
- This unit has a stainless-steel lock collar.
- This unit is factory lubricated with FDA/USDA-approved grease (class H1 lubricant) for incidental food contact.

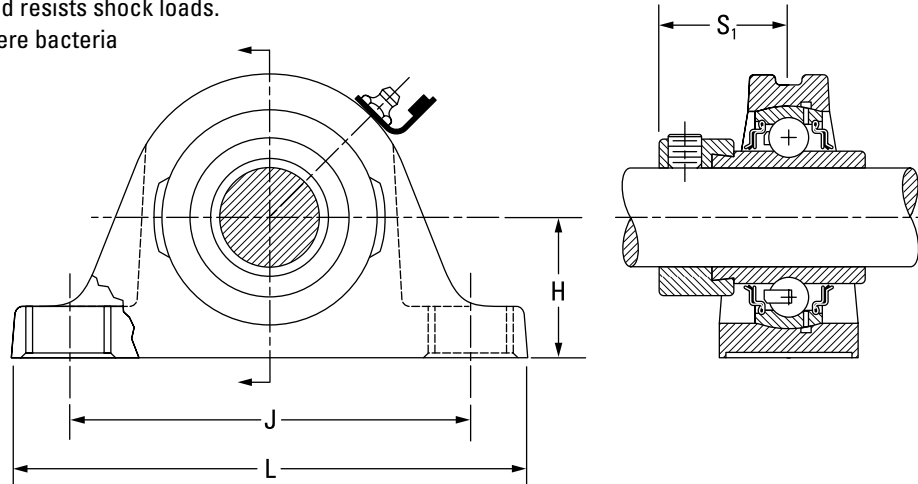

Unit ⁽¹⁾	Shaft Dia.	Type	RAK H	RAS H	J	L	S ₁	Static Load Rating	Dynamic Load Rating	Speed Rating	Bearing No.	Collar No.	
	in. mm		mm in.	mm in.	mm in.	mm in.	mm in.	N lbs.	N lbs.	RPM			
RAK/S	3/4	PT	31.75	33.34	96.04	127.00	26.59	6500	14500	9200	G1012KRRB	TDCF	S1012K SS
RAK/S	20		1 1/4	1 5/16	3 25/32	5	1 3/64	1460	3250		GE20KRRB	TDCF	SE20K SS
RAK	15/16	PT	33.34	36.51	104.78	139.70	26.99	7700	15800	6900	G1015KRRB	TDCF	S1015K SS
RAK/S	1 25		1 5/16	1 7/16	4 1/8	5 1/2	1 1/16	1730	3550		G1100KRRB	TDCF	S1100K SS
										7000	GE25KRRB	TDCF	SE25K SS
RAK/S	1 3/16	PT	39.69	42.86	117.48	157.16	30.16	11100	21800	5800	G1103KRRB	TDCF	S1103K SS
	1 1/4		1 9/16	1 11/16	4 5/8	6 3/16	1 3/16	2500	4900		G1103KRRB3	TDCF	S1103K3 SS
	30										GE30KRRB	TDCF	SE30K SS
RAK/S	1 1/4	PT	46.04	47.63	130.18	166.69	32.54	15100	28500	5500	G1104KRRB	TDCF	S1104K SS
	1 3/8		1 13/16	1 7/8	5 1/8	6 9/16	1 9/32	3400	6400		G1106KRRB	TDCF	S1106K SS
	1 7/16										G1107KRRB	TDCF	S1107K SS
	35										GE35KRRB	TDCF	SE35K SS
RAK/S	1 1/2	PT	49.21	49.21	136.53	179.39	34.93	19600	36300	4600	G1108KRRB	TDCF	S1108KT SS
	40		1 15/16	1 15/16	5 3/8	7 1/16	1 3/8	4400	8150		4400	GE40KRRB	TDCF

⁽¹⁾Option of low-base RAK or high-base RAS.

RCJ SERIES

- This unit is used for the main portion of the process where loads are lighter and corrosion protection is important.
- Durable corrosion-proof polymer housing with stainless-steel crush bushings in mounting holes and a stainless-steel grease fitting with a nylon cap.
- Polymer resists a broad range of acids and alkalis, as well as steam and continuous temperature up to 121° C (250° F), and brief exposure up to 160° C (320° F).
- The polymer strength exceeds static capacity of bearing; housing retains proper bearing fit and resists shock loads.
- The flush base contains no voids where bacteria can collect.
- Corrosion-resistant insert bearing with stainless-steel balls and a nylon retainer. The PT series also features industrial-duty contact seals with stainless-steel shroud caps.
- This unit has a stainless-steel lock collar.
- This unit is factory lubricated with FDA/USDA-approved grease (class H1 lubricant) for incidental food contact.

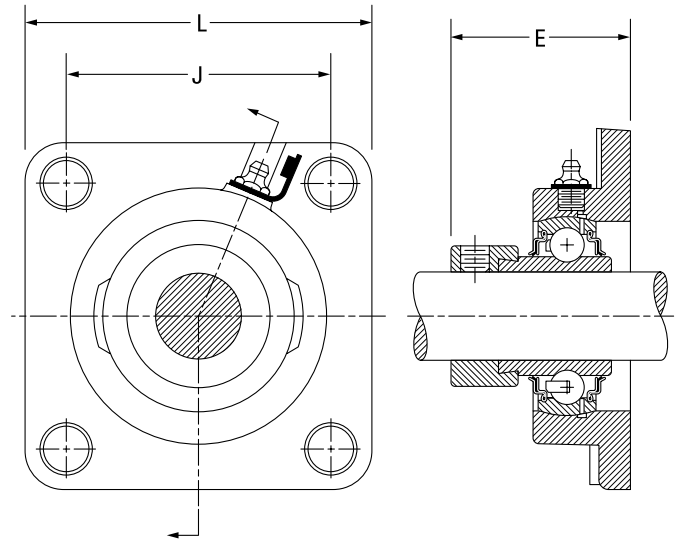

Unit	Shaft Dia.	Type	Dimensions			Static Load Rating	Dynamic Load Rating	Speed Rating	Bearing No.		Collar No.
			L	J	E						
	in. mm		mm in.	mm in.	mm in.	N lbs.	N lbs.	RPM			
RCJ	3/4	PT	85.73 3 3/8	63.50 2 1/2	43.26 1 45/64	6500 1460	14500 3250	9200	G1012KRRB	TDCF	S1012K SS
	20								GE20KRRB	TDCF	SE20K SS
RCJ	1	PT	95.25 3 3/4	69.85 2 3/4	46.04 1 13/16	7700 1730	15800 3550	6900 7000	G1100KRRB	TDCF	S1100K SS
	25								GE25KRRB	TDCF	SE25K SS
RCJ	1 3/16	PT	107.95 4 1/4	82.55 3 1/4	49.21 1 15/16	11100 2500	21800 4900	5800	G1103KRRB	TDCF	S1103K SS
	1 1/4S							G1103KRRB3	TDCF	S1103K3 SS	
	30							GE30KRRB	TDCF	SE30K SS	
RCJ	1 1/4	PT	117.48 4 5/8	92.08 3 5/8	52.78 2 5/64	15100 3400	28500 6400	5500	G1104KRRB	TDCF	S1104K SS
	1 3/8							G1106KRRB	TDCF	S1106K SS	
	1 7/16							G1107KRRB	TDCF	S1107K SS	
	35							GE35KRRB	TDCF	SE35K SS	
RCJ	1 1/2	PT	130.18 5 1/8	101.60 4	58.74 2 5/16	19600 4400	36300 8150	4600	G1108KRRB	TDCF	S1108KT SS
	40							GE40KRRB	TDCF	SE40K SS	

RCJT AND RTB SERIES

- This unit is used for the main portion of the process where loads are lighter and corrosion protection is important.
- Durable corrosion-proof polymer housing with stainless steel crush bushings in mounting holes and a stainless-steel grease fitting with a nylon cap.
- Polymer resists a broad range of acids and alkalis, as well as steam and continuous temperature up to 121° C (250° F), and brief exposure up to 160° C (320° F).
- The polymer strength exceeds static capacity of bearing; housing retains proper bearing fit and resists shock loads.
- The flush base contains no voids where bacteria can collect.
- Corrosion-resistant insert bearing with stainless-steel balls and a nylon retainer. The PT series also features industrial-duty contact seals with stainless-steel shroud caps.
- This unit has a stainless-steel lock collar.
- This unit is factory lubricated with FDA/USDA-approved grease (class H1 lubricant) for incidental food contact.

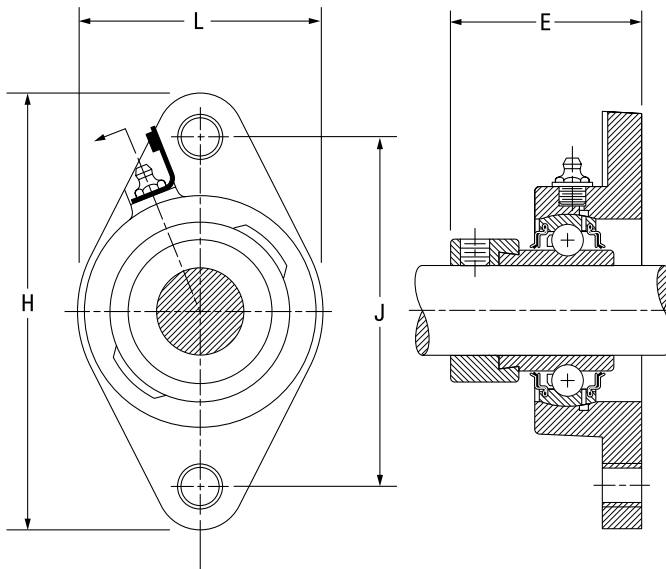

Unit	Shaft Dia.	Type	H	J	L	E	Static Load Rating	Dynamic Load Rating	Speed Rating	Bearing No.	Collar No.
	in. mm		mm in.	mm in.	mm in.	mm in.	N lbs.	N lbs.	RPM		
RCJT	3/4 20	PT	111.92 4 13/32	89.69 3 17/32	60.5 2 3/8	45.24 1 25/32	6500 1460	14500 3250	9200	G1012KRRB TDCF GE20KRRB TDCF	S1012K SS SE20K SS
RCJT	1 15/16 1 25	PT	123.83 4 7/8	99.22 3 29/32	69.85 2 3/4	46.04 1 13/16	7700 1730	15800 3550	6900 6900 7000	G1015KRRB TDCF G1100KRRB TDCF GE25KRRB TDCF	S1015K SS S1100K SS SE25K SS
RCJT	1 3/16 1 1/4 S 30	PT	141.29 5 5/16	116.68 4 19/32	79.38 3 1/8	49.21 1 15/16	11100 2500	21800 4900	5800 5500 5800	G1103KRRB TDCF G1103KRRB3 TDCF GE30KRRB TDCF	S1103K SS S1103K3 SS SE30K SS
RCJT	1 1/4 1 3/8 1 7/16 35	PT	155.58 6 1/8	130.18 5 1/8	92.08 3 5/8	52.78 2 9/64	15100 3400	28500 6400	5000 4800 5500 5000	G1104KRRB TDCF G1106KRRB TDCF G1107KRRB TDCF GE35KRRB TDCF	S1104K SS S1106K SS S1107K SS SE35K SS
RCJT	1 1/2 40	PT	171.45 6 3/4	143.67 5 21/32	104.78 4 1/8	58.74 2 5/16	19600 4400	36300 8150	4600 4400	G1108KRRB TDCF GE40KRRB TDCF	S1108KT SS SE40K SS

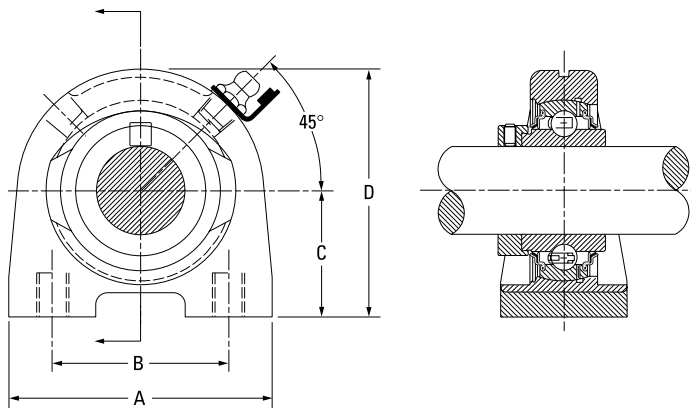

Unit	Shaft Dia.	Type	A	B	C	D	Static Load Rating	Dynamic Load Rating	Limiting Speed	Bearing No.	Collar No.
	in.		mm in.	mm in.	mm in.	mm in.	N lbs.	N lbs.	RPM		
RTB	1	PT	76.20 3	50.80 2	36.51 1 7/16	71.44 2 13/16	7700 1730	15300 3450	6900	G1100KRRB TDCF	S1100K SS

TIMKEN® FAFNIR® SURVIVOR® NT SERIES

Timken® Fafnir® Survivor® NT series mounted bearings offer superior corrosion resistance and durability for food and beverage industries, materials-handling operations, dairy and refrigeration applications, as well as HVAC, chemical, maritime and other highly corrosive environments (fig. 26). All materials used in the Survivor assemblies, including the grease, are approved for USDA- and FDA-compliant industries (table 25). The solid base is designed so food particles easily wash out.

Bearing inserts are coated in proprietary Timken thin-dense chrome that will not crack or peel. Combined with stainless-steel locking collars, these offer superior corrosion protection. The robust block option features an electroless nickel-plated housing.

Survivor NT series units are available as:

- High-base and low-base pillow blocks.
- Two-bolt and four-bolt flanged cartridges for popular shaft sizes of ½ in. through 2 15/16 in. (and select metric diameters).

- Take-up unit in the Survivor NT series in limited shaft sizes (RTU-NT). The bearing inserts are available with self-locking collars.

Survivor NT assemblies are dimensionally interchangeable with the current line of Timken cast-iron mounted bearings.

Our bearing inserts are coated in proprietary Timken thin-dense chrome that will not crack or peel. Inserts are available with a self-locking collar or a set screw locking device. Also available is Timken Shaft Guarding Technology (page 33), which uses a stainless-steel hardened band to transfer gripping pressure on the shaft. Unlike traditional set screws, which can dig into the shaft, there are no nicks, raised metal or permanent shaft damage. The stainless band won't corrode on the shaft. Mounted bearings with Shaft Guarding Technology also reduce change-out time.

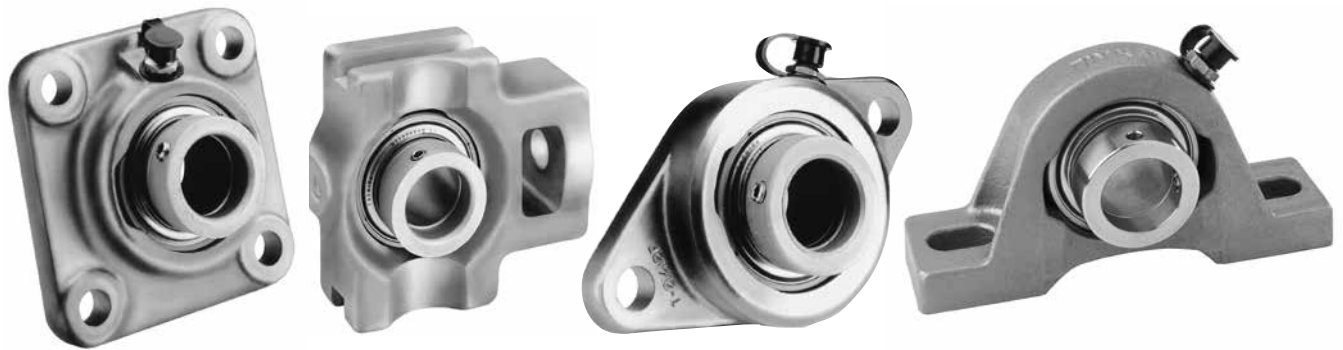

Fig. 26. Popular styles.

TABLE 25.

NT SERIES	
Component	Material
Balls	Stainless steel
Ball retainer	Nylon
Collar	Stainless steel
Rings	TDC plated
Grease	FDA approved
Housing finish	Nickel plating
Grease fitting	Stainless steel
Grease-fitting cover	Nylon
Seals	Synthetic rubber
Seal caps	Stainless steel
Set screw ⁽¹⁾	Stainless steel

⁽¹⁾Standard Survivor® NT units are only available in the R-series self-locking collar types. Set screw lock series (Y) units are available for minimum quantity orders.

ORDERING INFORMATION

To order complete Survivor nickel-plated assemblies, simply add the NT suffix to the cast-iron mounted bearing designations.

Example: **RCJT 1 NT** or **RAK 3/4 NT**

Survivor inserts can be ordered using Timken's standard part number for wide-inner-ring ball bearings with a TDCF suffix.

Example: **G1100KRRB + COLTDCF**

MOUNTED BALL BEARINGS

TIMKEN FAFNIR SURVIVOR NT SERIES • YCJ AND YCJT

NT YCJ AND YCJT SERIES

- This unit has the largest variety of configurations and shaft sizes and is used for the heaviest loads at the beginning of processing.
- Corrosion-resistant housing that is electroless nickel-plated and has a stainless-steel grease fitting. The protective cap withstands corrosion and prevents contamination.
- The corrosion-resistant insert bearing has stainless-steel balls with a nylon retainer. It also has industrial-duty contact seals with stainless-steel shroud caps.
- This unit has stainless-steel set screws with Shaft Guarding Technology.
- The unit is factory lubricated with FDA/USDA-approved grease (class H1 lubricant) for incidental food contact.

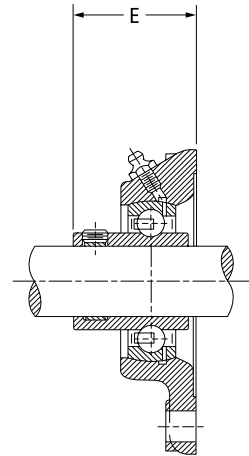
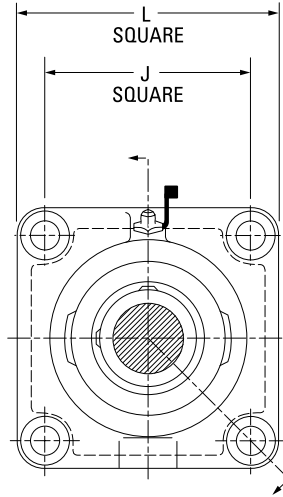

Unit	Shaft Dia.	Type	Dimensions			Static Load Rating	Dynamic Load Rating	Speed Rating	Bearing No.	
			L	J	E					
	in. mm		mm in.	mm in.	mm in.	mm in.	N lbs.	RPM		
YCJ	1 25	NT SGT	95.25	70.25	40.08	7700	15800	6900	GY1100KRRB	TDCF SGT
			3 3/4	2 49/64	1 37/64	1730	3550	7000	GYE25KRRB	TDCF SGT
YCJ	1 1/4 S 30	NT SGT	107.95	82.55	42.46	11100	21800	5500	GY1103KRRB3	TDCF
			4 1/4	3 1/4	1 43/64	2500	4900	5800	GYE30KRRB	TDCF SGT
YCJ	1 1/4 1 3/8 1 7/16 35	NT SGT	117.48	92.08	49.21	15100	28500	5500	GY1104KRRB	TDCF SGT
								5000	GY1106KRRB	TDCF SGT
								4800	GY1107KRRB	TDCF SGT
								4800	GYE35KRRB	TDCF SGT
YCJ	1 15/16	NT SGT	142.88	111.13	60.72	22700	39100	3600	GY1115KRRB	TDCF SGT
			5 5/8	4 3/8	2 25/64	5100	8800			
YCJ	2	NT SGT	161.93	130.18	64.69	28500	48000	3400	GY1200KRRB	TDCF SGT
			6 3/8	5 1/8	2 35/64	6400	10800			
YCJ	2 7/16	NT SGT	174.63	142.88	74.22	35600	58700	2800	GY1207KRRB	TDCF SGT
			6 7/8	5 5/8	2 59/64	8000	13200			

Unit	Shaft Dia.	Type	Dimensions				Static Load Rating	Dynamic Load Rating	Speed Rating	Bearing No.	
			H	J	L	E					
	in. mm		mm in.	mm in.	mm in.	mm in.	N lbs.	N lbs.	RPM		
YCJT	3/4	NT SGT	111.92	89.69	60.33	38.50	6500	14500	9200	GY1012KRRB	TDCF SGT
			4 13/32	3 17/32	2 3/8	1 39/64	1460	3250			
YCJT	1 25	NT SGT	123.83	99.22	69.85	40.08	7700	15800	6900	GY1100KRRB	TDCF SGT
			4 7/8	3 29/32	2 3/4	1 37/64	1730	3550	7000	GYE25KRRB	TDCF SGT
YCJT	1 3/16 1 1/4 S 30	NT SGT	141.29	116.68	79.38	43.66	11100	21800	5800	GY1103KRRB	TDCF SGT
									5500	GY1103KRRB3	TDCF
									5800	GYE30KRRB	TDCF SGT
YCJT	1 1/4 1 3/8 1 7/16 35	NT SGT	155.58	130.18	92.08	49.21	15100	28500	5500	GY1104KRRB	TDCF SGT
									5000	GY1106KRRB	TDCF SGT
									4800	GY1107KRRB	TDCF SGT
									4800	GYE35KRRB	TDCF SGT
YCJT	1 1/2	NT SGT	171.45	143.67	104.78	54.37	19600	36300	4600	GY1108KRRB	TDCF SGT
			6 3/4	5 21/32	4 1/8	2 9/64	4400	8150	4400	GYE40KRRB	TDCF SGT
YCJT	1 11/16 1 3/4	NT SGT	179.39	148.03	111.13	55.56	20000	36300	4100	GY1111KRRB	TDCF SGT
			7 1/16	5 53/64	4 3/8	2 3/16	4500	8150	3900	GY1112KRRB	TDCF SGT
YCJT	1 15/16	NT SGT	188.91	157.16	115.89	60.72	22700	39100	3600	GY1115KRRB	TDCF SGT
			7 7/16	6 3/16	4 9/16	2 25/64	5100	8800			
YCJT	2 3/16	NT SGT	215.90	184.15	127.00	64.69	28500	48000	3100	G1203KRRB	TDCF SGT
			8 1/2	7 1/4	5	2 39/64	6400	10800			

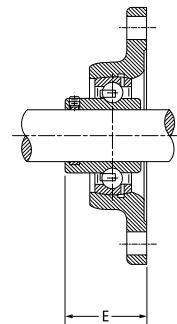
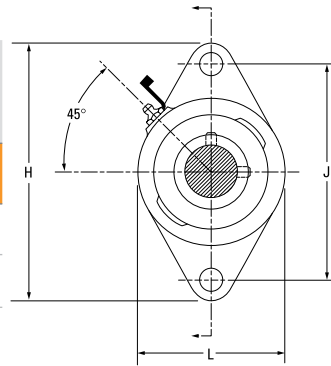

RAK/S SERIES

- This unit has the largest variety of configurations and shaft sizes and is used for the heaviest loads at the beginning of processing.
- Corrosion-resistant housing that is electroless nickel-plated and has a stainless-steel grease fitting. The protective cap withstands corrosion and prevents contamination.
- The corrosion-resistant insert bearing has stainless-steel balls with a nylon retainer. It also has industrial-duty contact seals with stainless-steel shroud caps.
- This unit has a stainless-steel lock collar.
- The unit is factory lubricated with FDA/USDA-approved grease (class H1 lubricant) for incidental food contact.

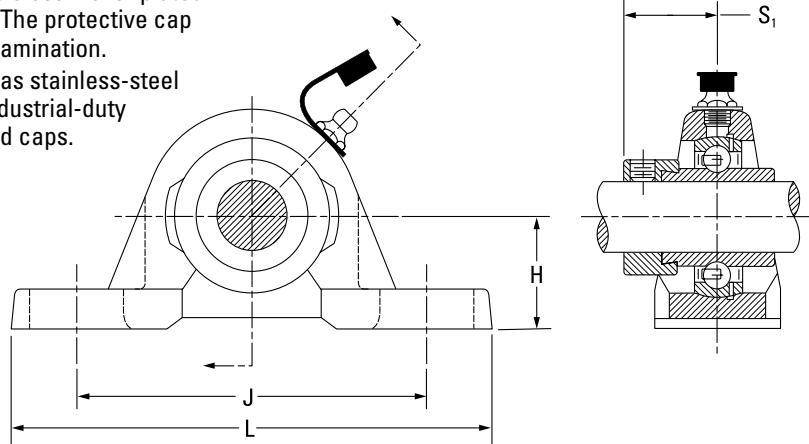

Unit ⁽¹⁾	Shaft Dia.	Type						Static Load Rating	Dynamic Load Rating	Speed Rating	Bearing No.		Collar No.										
			RAK H	RAS H	J	L	S ₁																
	in. mm		mm in.	mm in.	mm in.	mm in.	mm in.	N lbs.	N lbs.	RPM													
RAK/S	1/2	NT	26.99	30.16	92.08	123.83	23.42	4700	10700	13800	G1008KRRB	TDCF	S1008K SS										
	5/8		1 1/6	1 3/16	3 5/8	4 7/8	59/64	1060	2400	11000				G1010KRRB	TDCF	S1010K SS							
RAK/S	3/4	NT	31.75	33.34	96.04	127.00	26.59	6500	14500	9200	G1012KRRB	TDCF	S1012K SS										
RAK	15/16	NT	33.34	36.51	104.78	139.70	26.99	7700	15800	6900	G1015KRRB	TDCF	S1015K SS										
RAK/S	1									1 5/16				1 7/16	4 1/8	5 1/2	1 1/6	1730	3550	6900	G1100KRRB	TDCF	S1100K SS
RAK/S	25									1 5/16				1 7/16	4 1/8	5 1/2	1 1/6	7000		7000	GE25KRRB	TDCF	SE25K SS
RAK/S	1 3/16	NT	39.69	42.86	117.48	157.16	30.16	11100	21800	5800	G1103KRRB	TDCF	S1103K SS										
	1 1/4									1 9/16				1 11/16	4 5/8	6 3/16	1 3/16	2500	4900	5500	G1103KRRB3	TDCF	S1103K3 SS
	30									1 9/16				1 11/16	4 5/8	6 3/16	1 3/16	5800		5800	GE30KRRB	TDCF	SE30K SS
RAK/S	1 1/4	NT	46.04	47.63	130.18	166.69	32.54	15100	28500	5500	G1104KRRB	TDCF	S1104K SS										
	1 3/8									1 13/16				1 7/8	5 1/8	6 9/16	1 9/32	3400	6400	5000	G1106KRRB	TDCF	S1106K SS
	1 7/16									1 13/16				1 7/8	5 1/8	6 9/16	1 9/32	4800		4800	G1107KRRB	TDCF	S1107K SS
RAK/S	1 1/2	NT	49.21	49.21	136.53	179.39	34.93	19600	36300	4600	G1108KRRB	TDCF	S1108KT SS										
	40	1 15/16	1 15/16	5 3/8	7 1/16	1 3/8	4400	8150	4400	GE40KRRB	TDCF	SE40K SS											
RAK/S	1 11/16	NT	52.39	53.98	149.23	191.29	34.93	20000	36300	4100	G1111KRRB	TDCF	S1111K SS										
	1 3/4									2 1/16				2 1/8	5 7/8	7 11/32	1 3/8	4500	8150	3900	G1112KRRB	TDCF	S1112K SS
RAK/S	1 15/16	NT	55.56	57.15	157.96	200.03	38.10	22700	39100	3600	G1115KRRB	TDCF	S1115K SS										
RAK	50									2 3/16				2 1/4	6 7/32	7 7/8	1 1/2	5100	8800	3600	GE50KRRB	TDCF	SE50K SS
RAK/S	2	NT	61.91	63.50	176.21	222.25	43.66	28500	48000	3400	G1200KRRB	TDCF	S1200K SS										
	2 3/16									2 7/16				2 1/2	6 15/16	8 3/4	1 23/32	6400	10800	3100	G1203KRRB	TDCF	S1203K SS
RAK/S	2 7/16	NT	68.26	69.85	188.12	239.71	46.83	35600	58700	2800	G1207KRRB	TDCF	S1207K SS										
			2 11/16	2 3/4	7 13/32	9 7/16	1 27/32	8000	13200														
RAK/S	2 11/16	NT	76.20	—	203.20	266.70	51.59	42900	69400	2600	G1211KRRB	TDCF	S1211K SS										
			3		8	10 1/2	2 1/32	9650	15600														
RAK/S	2 15/16	NT	84.14	82.55	241.30	304.80	54.77	43600	69400	2300	G1215KRRB	TDCF	S1215K SS										
			3 5/16	3 1/4	9 1/2	12	2 5/32	9800	15600														

⁽¹⁾Option of low-base RAK or high-base RAS.

RCJ SERIES

- This unit has the largest variety of configurations and shaft sizes and is used for the heaviest loads at the beginning of processing.
- Corrosion-resistant housing that is electroless nickel-plated and has a stainless-steel grease fitting. The protective cap withstands corrosion and prevents contamination.
- The corrosion-resistant insert bearing has stainless-steel balls with a nylon retainer. It also has industrial-duty contact seals with stainless-steel shroud caps.
- This unit has a stainless-steel lock collar.
- The unit is factory lubricated with FDA/USDA-approved grease (class H1 lubricant) for incidental food contact.

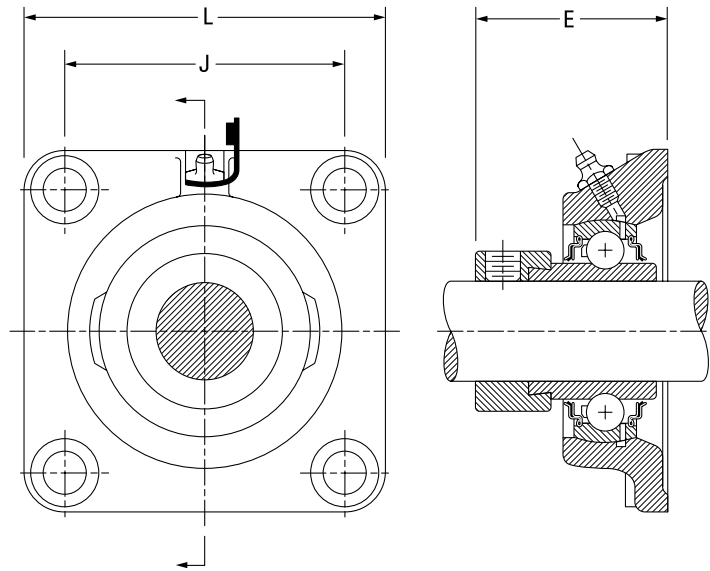

Unit	Shaft Dia.	Type	Dimensions			Static Load Rating	Dynamic Load Rating	Speed Rating	Bearing No.	Collar No.	
			L	J	E						
	in. mm		mm in.	mm in.	mm in.	N lbs.	N lbs.	RPM			
RCJ	1/2 5/8	NT	76.20	53.98	40.10	4700	10700	13800	G1008KRRB	TDCF	S1008K SS
			3	2 1/8	1 19/32	1060	2400	11000	G1010KRRB	TDCF	S1010K SS
RCJ	3/4	NT	85.73	63.50	46.43	6500	14500	9200	G1012KRRB	TDCF	S1012K SS
			3 3/8	2 1/2	1 59/64	1460	3250				
RCJ	1 25	NT	95.25	69.85	46.80	7700	15800	6900	G1100KRRB	TDCF	S1100K SS
			3 3/4	2 3/4	1 27/32	1730	3550	7000	GE25KRRB	TDCF	SE25K SS
RCJ	1 3/16 1 1/4S 30	NT	107.95	82.55	50.80	11100	21800	5800	G1103KRRB	TDCF	S1103K SS
			4 1/4	3 1/4	2	2500	4900	5500	G1103KRRB3	TDCF	S1103K3 SS
								5800	GE30KRRB	TDCF	SE30K SS
RCJ	1 1/4 1 3/8 1 7/16	NT	117.48	92.08	53.58	15100	28500	5500	G1104KRRB	TDCF	S1104K SS
			4 5/8	3 5/8	2 7/64	3400	6400	5000	G1106KRRB	TDCF	S1106K SS
								4800	G1107KRRB	TDCF	S1107K SS
RCJ	1 1/2 40	NT	130.18	101.60	59.13	19600	36300	4600	G1108KRRB	TDCF	S1108KT SS
			5 1/8	4	2 21/64	4400	8150	4400	GE40KRRB	TDCF	SE40K SS
RCJ	1 11/16 1 3/4	NT	136.53	104.78	59.13	20000	36300	4100	G1111KRRB	TDCF	S1111K SS
			5 3/8	4 1/8	2 21/64	4500	8150	3900	G1112KRRB	TDCF	S1112K SS
RCJ	1 15/16	NT	142.88	111.13	66.68	22700	39100	3600	G1115KRRB	TDCF	S1115K SS
RCJ	2 2 3/16	NT	161.93	130.18	75.41	28500	48000	3400	G1200KRRB	TDCF	S1200K SS
			6 3/8	5 1/8	2 31/32	6400	10800	3100	G1203KRRB	TDCF	S1203K SS
RCJ	2 7/16	NT	174.63	142.88	81.76	35600	58700	2800	G1207KRRB	TDCF	S1207K SS
RCJ	2 11/16	NT	187.33	149.23	90.49	42900	69400	2600	G1211KRRB	TDCF	S1211K SS
			7 3/8	5 7/8	3 9/16	9650	15600				
RCJ	2 15/16	NT	196.85	152.40	96.84	43600	69400	2300	G1215KRRB	TDCF	S1215K SS
			7 3/4	6	3 13/16	9800	15600				

RCJT SERIES

- This unit has the largest variety of configurations and shaft sizes and is used for the heaviest loads at the beginning of processing.
- Corrosion-resistant housing that is electroless nickel-plated and has a stainless-steel grease fitting. The protective cap withstands corrosion and prevents contamination.
- The corrosion-resistant insert bearing has stainless-steel balls with a nylon retainer. It also has industrial-duty contact seals with stainless-steel shroud caps.
- This unit has a stainless-steel lock collar.
- The unit is factory lubricated with FDA/USDA-approved grease (class H1 lubricant) for incidental food contact.

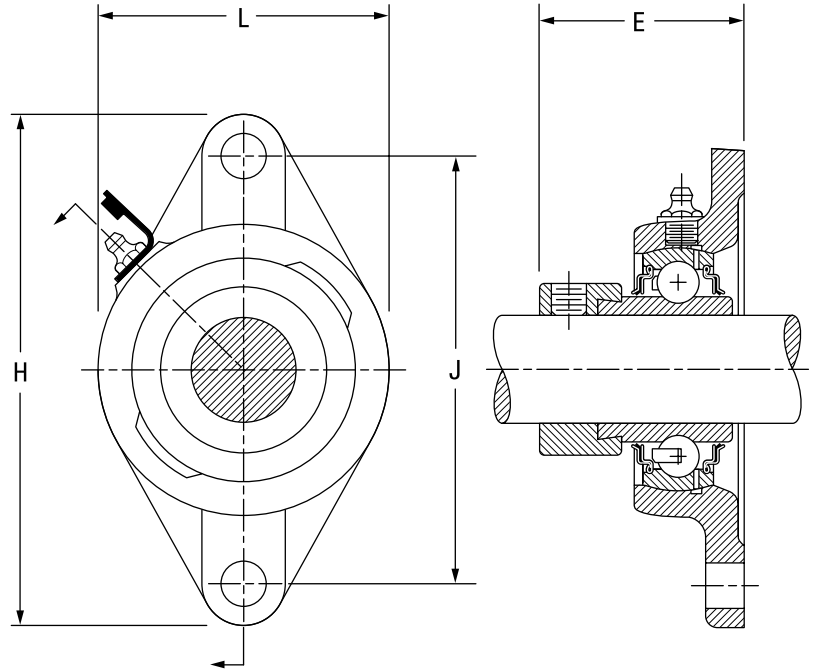

Unit	Shaft Dia.	Type	Dimensions				Static Load Rating	Dynamic Load Rating	Speed Rating	Bearing No.		Collar No.	
			H	J	L	E							
	in. mm		mm in.	mm in.	mm in.	mm in.	N lbs.	N lbs.	RPM				
RCJT	1/2 5/8	NT	98.43	76.20	54.0	40.61	4700	10700	13800	G1008KRRB	TDCF	S1008K SS	
			3 7/8	3	2 1/8	1 39/64	1060	2400	11000	G1010KRRB	TDCF	S1010K SS	
RCJT	3/4	NT	111.92	89.69	60.5	46.43	6500	14500	9200	G1012KRRB	TDCF	S1012K SS	
			4 13/32	3 17/32	2 3/8	1 53/64	1460	3250					
RCJT	1 25	NT	123.83	99.22	69.85	46.83	7700	15800	6900	G1100KRRB	TDCF	S1100K SS	
			4 7/8	3 29/32	2 3/4	1 27/32	1730	3550	7000	GE25KRRB	TDCF	SE25K SS	
RCJT	1 3/16 1 1/4S 30	NT	141.29	116.68	79.38	50.80	11100	21800	5800	G1103KRRB	TDCF	S1103K SS	
			5 9/16	4 19/32	3 1/8	2	2500	4900	5500	G1103KRRB3	TDCF	S1103K3 SS	
									5800	GE30KRRB	TDCF	SE30K SS	
RCJT	1 1/4 1 3/8 1 7/16	NT	155.58	130.18	92.08	53.58	15100	28500	5500	G1104KRRB	TDCF	S1104K SS	
			6 1/8	5 1/8	3 5/8	2 7/64	3400	6400	5000	G1106KRRB	TDCF	S1106K SS	
									4800	G1107KRRB	TDCF	S1107K SS	
RCJT	1 1/2 40	NT	171.45	143.67	104.78	59.13	19600	36300	4600	G1108KRRB	TDCF	S1108KT SS	
			6 3/4	5 21/32	4 1/8	2 21/64	4400	8150	4400	GE40KRRB	TDCF	SE40K SS	
RCJT	1 11/16 1 3/4	NT	179.39	148.03	111.13	59.13	20000	36300	4100	G1111KRRB	TDCF	S1111K SS	
			7 1/16	5 27/32	4 3/8	2 21/64	4500	8150	3900	G1112KRRB	TDCF	S1112K SS	
RCJT	1 15/16	NT	188.91	157.16	115.89	66.68	22700	39100	3600	G1115KRRB	TDCF	S1115K SS	
			7 7/16	6 3/16	4 9/16	2 5/8	5100	8800					
RCJT	2 2 3/16	NT	215.90	184.15	127.00	75.41	28500	48000	3400	G1200KRRB	TDCF	S1200K SS	
			8 1/2	7 1/4	5	2 31/32	6400	10800	3100	G1203KRRB	TDCF	S1203K SS	

RTU SERIES

- This unit has the largest variety of configurations and shaft sizes and is used for the heaviest loads at the beginning of processing.
- Corrosion-resistant housing that is electroless nickel-plated and has a stainless-steel grease fitting. The protective cap withstands corrosion and prevents contamination.
- The corrosion-resistant insert bearing has stainless-steel balls with a nylon retainer. It also has industrial-duty contact seals with stainless-steel shroud caps.
- This unit has a stainless-steel lock collar.
- The unit is factory lubricated with FDA/USDA-approved grease (class H1 lubricant) for incidental food contact.

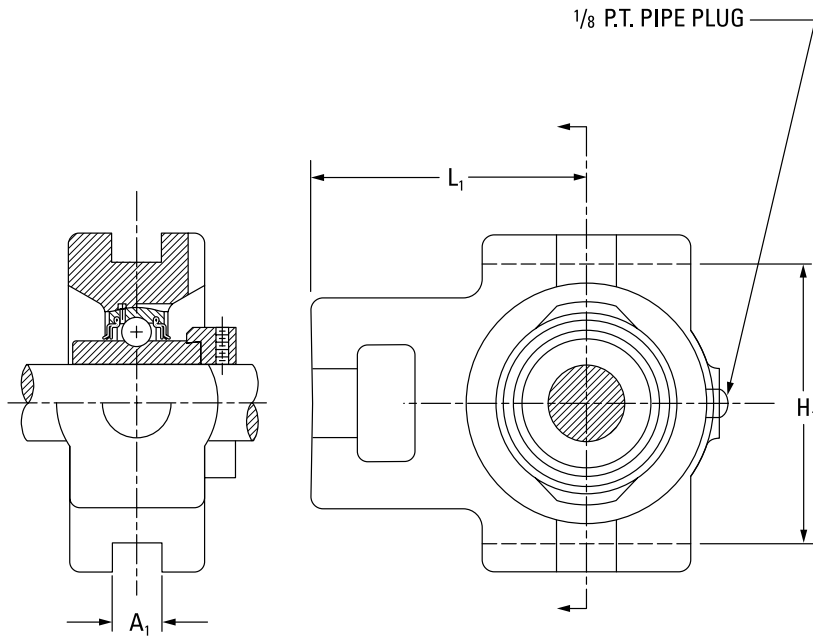

Unit	Shaft Dia.	Type	Dimensions			Static Load Rating	Dynamic Load Rating	Speed Rating	Bearing No.	Collar No.	
			A ₁	H ₁	L ₁						
	in. mm		mm in.	mm in.	mm in.	N lbs.	N lbs.	RPM			
RTU	1	NT	13.49	76.20	67.47	7700	15300	6900	G1100KRRB	TDCF	S1100K SS
	25		17/32	3	2 21/32	1730	3450	7000	GE25KRRB	TDCF	SE25K SS
RTU	1 3/16	NT	13.49	88.90	72.23	11100	21800	5800	G1103KRRB	TDCF	S1103K SS
	30		17/32	3 1/2	2 27/32	2500	4900	5800	GE30KRRB	TDCF	SE30K SS
RTU	1 1/4	NT	13.49 17/32	88.90 3 1/2	74.61	15100	28500	5500	G1104KRRB	TDCF	S1104K SS
	1 3/8				2 15/16	3400	6400	5500	G1106KRRB	TDCF	S1106K SS
	1 7/16						4800		G1107KRRB	TDCF	S1107K SS
RTU	1 1/2	NT	17.46	100.81	88.11	19600	36300	4600	G1108KRRB	TDCF	S1108KT SS
	40		11/16	3 31/32	3 15/32	4400	8150	4400	GE40KRRB	TDCF	SE40K SS
RTU	1 11/16	NT	17.46 11/16	100.81 3 31/32	88.11 3 15/32	20000	36300	4100	G1111KRRB	TDCF	S1111K SS
	1 3/4					4500	8150	3900	G1112KRRB	TDCF	S1112K SS
RTU	1 15/16	NT	17.46 11/16	100.81 3 31/32	91.28 3 19/32	22700	39100	3600	G1115KRRB	TDCF	S1115K SS
	50					5100	8800		GE50KRRB	TDCF	SE50K SS
RTU	2	NT	26.99	129.38	119.86	28500	48000	3400	G1200KRRB	TDCF	S1200K SS
	2 3/16		1 1/16	5 3/32	4 23/32	6400	10800	3100	G1203KRRB	TDCF	S1203K SS
RTU	2 7/16	NT	26.99 1 1/16	129.38 5 3/32	119.86 4 23/32	35600 8000	58700 13200	2800	G1207KRRB	TDCF	S1207K SS

MISCELLANEOUS MOUNTED BEARINGS IDLER PULLEY UNITS

- A pressed-steel pulley and a Timken® precision ball bearing with rubber seals are combined to make a self-contained unit.
- Two pulley designs are available. One for V-belts and another for the backs of V-belts. Both are made for A, B, C and D section belts.
- A chain idler, identical in construction to the flat idler, is available, with the addition of an assembled rubber tire (part number A-10927). The rubber tire cushions the chain, preventing undue wear on the pulley surface or chain.
- Idler pulley units feature a Timken® single-row radial ball bearing with an inner ring extended on both sides. This

provides clearance for abutting parts and greater support on the shaft.

- Contact-type rubber seals help ensure positive retention for lubricant and full protection against dirt, dust and foreign matter.
- All units are non-relubricatable. Special features include smoothly rolled-over edges, eliminating belt chafing and scuffing. The weep holes on the rivet circle allow water drainage when the pulley is mounted in a horizontal position.

To order, specify PULLEY NUMBER.

Example: 008-10853 Idler Pulley.

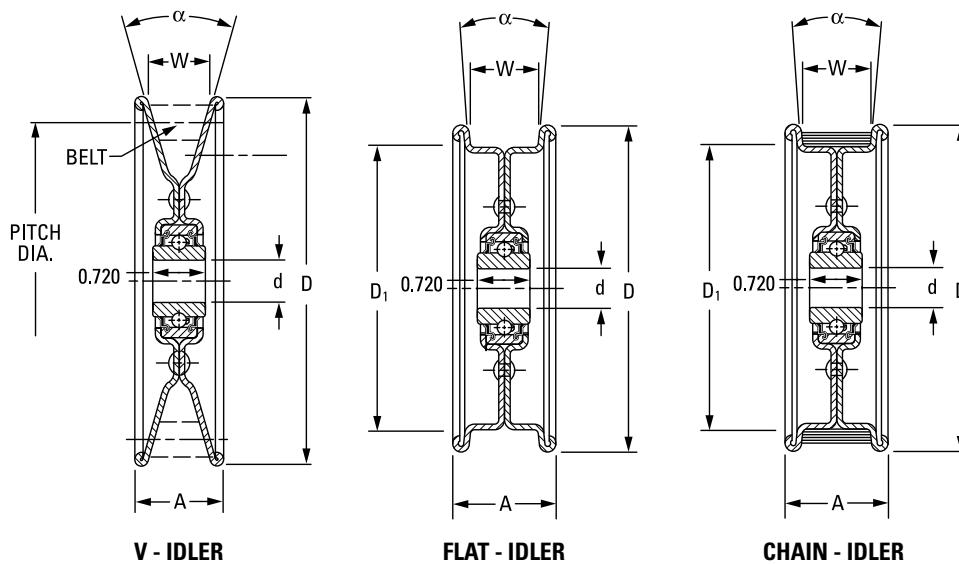

Pulley No.	α Included Angle Degrees	Bearing No.	Bore		A	D ₁	W	Wt.
			d	D				
			mm in.	mm in.	mm in.	mm in.	mm in.	kg lbs.
V IDLERS								
006-11520A ⁽¹⁾	32	WS3NPP3	10.010/9.780 0.3940/0.3850	76.2 3	19.0 ¾	—	12.45 0.049	0.145 0.32
10874 ⁽²⁾	34	203NPP	17.000/16.993 0.6693/0.6690	101.6 4	22.2 ⅞	—	12.70 0.500	0.417 0.92
010-10874	34	203KRR2	16.130/16.260 0.6350/0.6400	101.6 4	22.2 7.8	—	12.70 0.500	0.435 0.96
008-10482	32	203KRR5	13.080/12.950 0.5150/0.5100	128.6 5 1/16	31.8 1 ¼	—	22.15 0.872	0.572 1.26
010-10482	32	203KRR2	16.130/16.260 0.6350/0.6400	128.6 5 1/16	31.8 1 ¼	—	22.15 0.872	0.558 1.23
008-10853	32	203KRR5	13.080/12.950 0.5150/0.5100	185.7 7 5/16	31.8 1 ¼	—	22.15 0.872	1.134 2.50
010-10853	32	203KRR2	16.13/16.260 0.6350/0.6400	185.7 7 5/16	31.8 1 ¼	—	22.15 0.872	1.120 2.47

⁽¹⁾Inner ring width 13.891 mm – 13.764 mm; (0.5469 in. – 0.5419 in.)

⁽²⁾12 mm (0.4724 in.) inner ring width 11.999 mm – 11.872 mm (0.4724 in. – 0.4674 in.).

Continued on next page.

MOUNTED BALL BEARINGS

MISCELLANEOUS MOUNTED BEARINGS • IDLER PULLEY UNITS

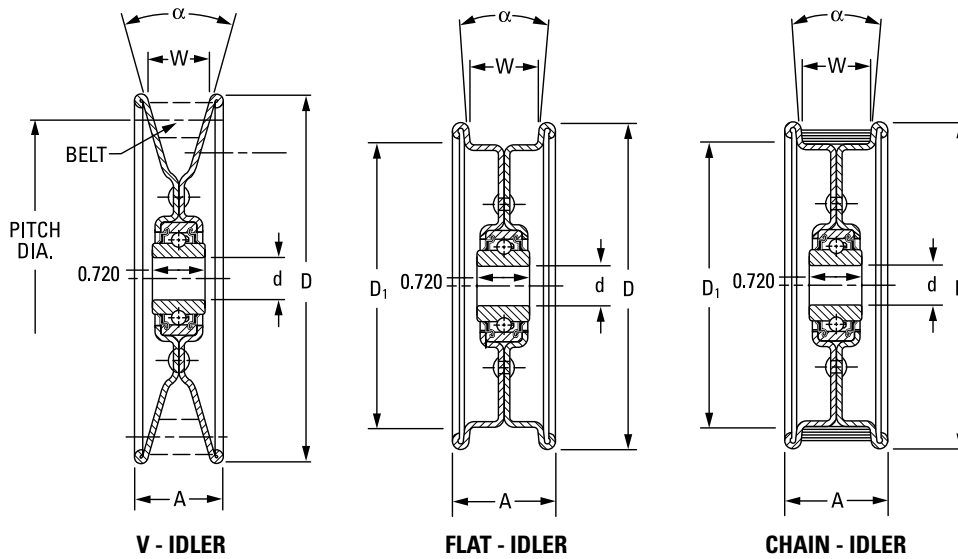

Continued from previous page.

Pulley No.	α Included Angle Degrees	Bearing No.	Bore		D	A	D ₁	W	Wt.
			d	D					
			mm in.	mm in.	mm in.	mm in.	mm in.	kg lbs.	
FLAT IDLERS									
006-11581A ⁽¹⁾	10	WS3NPP3	10.01/9.78 0.394/0.385	92.1 3 5/8	30.6 1 7/32	76.2 3	22.2 7/8	0.259 0.57	
008-10601	10	203KRR5	13.08/12.95 0.515/0.510	117.5 4 5/8	36.5 1 7/16	101.6 4	25.4 1	0.503 1.11	
010-10601	10	203KRR2	16.13/16.26 0.635/0.640	117.5 4 5/8	36.5 1 7/16	101.6 4	25.4 1	0.490 1.08	
FLAT IDLERS									
008-10483	10	203KRR5	13.08/12.95 0.515/0.510	158.8 6 1/4	36.5 1 7/16	139.7 5 1/2	25.4 1	0.803 1.77	
010-10483	10	203KRR2	16.13/16.26 0.635/0.640	158.8 6 1/4	36.5 1 7/16	139.7 5 1/2	25.4 1	0.789 1.74	
008-10650	50	203KRR5	13.08/12.95 0.515/0.510	158.8 6 1/4	36.5 1 7/16	139.7 5 1/2	25.4 1	0.785 1.73	
010-10650	50	203KRR2	16.13/16.26 0.635/0.640	158.8 6 1/4	41.3 1 7/16	139.7 5 1/2	25.4 1	0.771 1.70	
008-11515	10	203KRR5	13.08/12.95 0.515/0.510	222.2 8 3/4	35.7 1 13/32	203.2 8	25.4 1	1.238 2.73	
010-11515	10	203KRR2	16.13/16.26 0.635/0.640	222.2 8 3/4	35.7 1 13/32	203.2 8	25.4 1	1.225 2.70	
008-10731	10	203KRR5	13.08/12.95 0.515/0.510	222.2 8 3/4	48.4 1 29/32	203.2 8	38.1 1 1/2	1.488 3.38	
010-10731	10	203KRR2	16.13/16.26 0.635/0.640	222.2 8 3/4	48.4 1 29/32	203.2 8	38.1 1 1/2	1.474 3.25	
CHAIN IDLERS									
008-10927	10	203KRR5	13.08/12.95 0.515/0.510	117.5 4 5/8	36.5 1 7/16	111.1 4 3/8	25.4 1	0.576 1.27	
010-10927	10	203KRR2	16.13/16.26 0.635/0.640	117.5 4 5/8	36.5 1 7/16	111.1 4 3/8	25.4 1	0.562 1.24	

⁽¹⁾Inner ring width 13.891 mm – 13.764 mm; (0.5469 in. – 0.5419 in.)

⁽²⁾12 mm (0.4724 in.) inner ring width 11.999 mm – 11.872 mm (0.4724 in. – 0.4674 in.).

ROLLER CHAIN IDLER SPROCKETS

- The sintered-steel sprockets are hardened and perform well at an economical cost.
- The roller chain idler sprocket replaces the hardened-plate steel sprockets on most applications.
- All units are non-relubricatable.

To order, specify **SPROCKET NUMBER**.

Example: 010-5017S Idler Sprocket.

Order all bearings with E8728 specification.

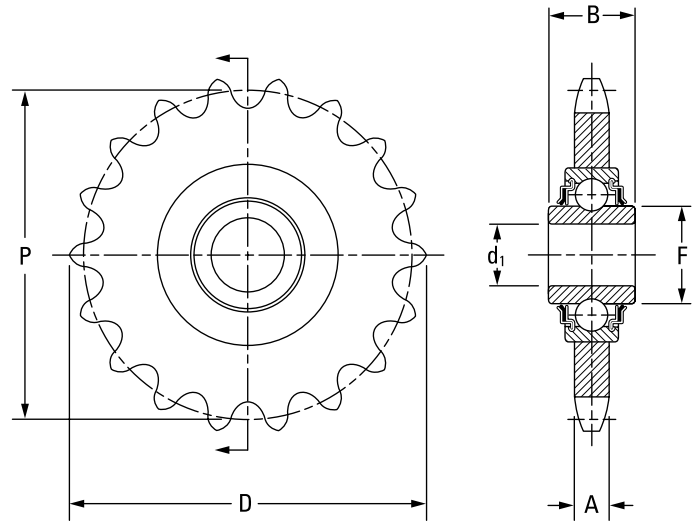

Sprocket No.	Bearing No.	Bore d_1	A.S.A. Chain No.	No. of Teeth	Pitch						Bearing Radial Load Rating @500 RPM	Wt.
						P	D	A	F	B		
		mm in.			mm in.	mm in.	mm in.	mm in.	mm in.	mm in.	N lbs.	kg lbs.
008-4018-S	203KRR5	13.08/12.95 0.5150/0.5000	40	18	12.7 1/2	73.13 2.879	79.88 3.145	7.21 0.284	24.43 0.962	18.29 0.72	3550 800	0.200 0.44
008-5017-S	203KRR5	13.08/12.95 0.5150/0.5000	50	17	15.9 5/8	86.36 3.400	94.72 3.729	8.71 0.343	24.43 0.962	18.29 0.72	3550 800	0.299 0.66
008-6015-S	203KRR5	13.08/12.95 0.5150/0.5000	60	15	19.0 3/4	91.62 3.607	101.32 3.989	11.66 0.459	24.43 0.962	18.29 0.72	3550 800	0.417 0.92
010-4018-S	203KRR2	16.26/16.13 0.6400/0.6350	40	18	12.7 1/2	73.13 2.879	79.88 3.145	7.21 0.284	24.43 0.962	18.29 0.72	3550 800	0.200 0.44
010-5017-S	203KRR2	16.26/16.13 0.6400/0.6350	50	17	15.9 5/8	86.36 3.400	94.72 3.729	8.71 0.343	24.43 0.962	18.29 0.72	3550 800	0.299 0.66
010-6015-S	203KRR2	16.26/16.13 0.6400/0.6350	60	15	19.0 3/4	91.62 3.607	101.32 3.989	11.66 0.459	24.43 0.962	18.29 0.72	3550 800	0.417 0.92
011H-5017-S	204KRR2	17.65/17.52 HEX 0.6950/0.6900	50	17	15.9 5/8	86.36 3.400	94.72 3.729	8.71 0.343	28.73 1.131	18.29 0.72	3550 800	0.299 0.66
011H-6015-S	204RR2	17.65/17.52 HEX 0.6950/0.6900	60	15	19.0 3/4	91.62 3.607	101.32 3.989	11.66 0.459	24.43 0.962	18.29 0.72	3550 800	0.417 0.92
012-8012-S	204RR6	19.18/19.05 0.7500/0.7505	80	12	25.4 1	98.15 3.864	110.41 4.347	14.60 0.575	26.62 1.048	15.49 0.61	4800 1080	0.676 1.49

REPLACEMENT BEARINGS

TABLE 26. MOUNTED BEARING REPLACEMENT BEARINGS

Mounted Bearings	Replacement Bearing Assembly	Features	Part No.
C	MUB replaced by 1000KRB & Col.	Standard series (SM) wide inner ring (B-type), collar, caps and wire	Example: 2 11/16 in. (uses MUB 2 11/16 in.)
DRNR	1000KR & Col. (Two)	Single R-seal (A-type), complete bearing number marked on seal	Example: DRNR 1 3/16 in. (uses two 1103KR & Col.)
FLCT	RA000RRB & Col.	Non-relubricatable; B-spherical outer ring; RR-double R-seal	Bearing identification marked on seal.
GRFD, GRFDR, GRFTD, GRFTDR	G1000KRRB & Col.	G-relubricatable; B-spherical outer ring; RR-double R-seal	Complete bearing number marked on seal. Example: GRFD 1 3/16 in. (uses G1103KRRB & Col.)
GRKD, GRSD	G1000KRRB & Col.	G-relubricatable; B-spherical outer ring; RR-double R-seal	Complete bearing number marked on seal. Example: GRKD 1 3/16 in. (uses G1103KRRB & Col.)
GVFD, GVFDR, GVFTD, GVFTDR	GRA000RRB & Col.	G-relubricatable; B-spherical outer ring; RR-double R-seal	Bearing identification marked on seal.
GVKD, GVSD	GRA000RRB & Col.	G-relubricatable; B-spherical outer ring; RR-double R-seal	Bearing identification marked on seal.
LAK, LAS	G1000KLLB & Col.	G-relubricatable; B-spherical outer ring; LL-double Mechani-seal	Complete bearing number marked on seal. Example: LAK 1 3/16 in. (uses G1103KLLB & Col.)
LAKHL	1000KLS & Col.	L-single Mechani-seal; S-external self-aligning	Complete bearing number marked on seal. Example: LAKHL 1 3/16 in. (uses 1103KLS & Col.)
LAO, LSAO	GN000KLLB & Col.	G-relubricatable; B-spherical outer ring; LL-double Mechani-seal	Complete bearing number marked on seal. Example: LAO 1 3/16 in. (uses GN103KLLB & Col.)
LCJ, LCJT	G1000KLLB & Col.	G-relubricatable; B-spherical outer ring; LL-double Mechani-seal	Complete bearing number marked on seal. Example: LCJ 1 3/16 in. (uses G1103KLLB & Col.)
LCJO	GN000KLLB	G-relubricatable; N-Heavy series; B-spherical outer ring; LL-double Mechani-seal	Complete bearing number marked on seal. Example: LCJO 1 3/16 in. (uses GN103KLLB & Col.)
PB, PBS, VKD, VSD	RA000RRB & Col.	Non-relubricatable; B-spherical outer ring; RR-double R-seal	Bearing identification marked on seal.
RA Flangette, RAT Flangette	RA000RRB & Col.	Non-relubricatable; B-spherical outer ring; RR-double R-seal	Bearing identification marked on seal.
RA Relubricatable Flangette	GRA000RRB & Col.	G-relubricatable; B-spherical outer ring; RR-double R-seal	To order, specify bearings and markings. Example: 1-GRA103RRB & Col., 1-G62MSA marking, 1-G62MSB marking
RAK, RAS, RAKH, RSA	G1000KRRB & Col.	G-relubricatable; B-spherical outer ring; RR-double R-seal	Complete bearing number marked on seal. Example: RAK 1 3/16 in. (uses G1103KRRB & Col.)
RAKHL	1000KRS & Col.	R-Single R-seal; S-external self-aligning	Complete bearing number marked on seal. Example: RAKHL 1 3/16 in. (uses 1103KRS & Col.)
RAKN, RASN	1000KRRB & Col.	Non-relubricatable; B-spherical outer ring; RR-double R-seal	Complete bearing number marked on seal. Example: RAKN 1 3/16 in. (uses 1103KRRB & Col.)
RAO, RSAO	GN000KRRB & Col.	G-relubricatable; B-spherical outer ring; RR-double R-seal	Complete bearing number marked on seal. Example: RSAO 3 3/16 in. (uses GN303KRRB & Col.)
RASC	GC1000KRRB & Col.	G-relubricatable; C-concentric collar; B-spherical outer ring; RR-double R-seal	Complete bearing number marked on seal. Example: RASC 1 3/16 in. (uses GC1103KRRB & Col.)
RCJ, RCJT, RC	G1000KRRB & Col.	G-relubricatable; B-spherical outer ring; RR-double R-seal	Complete bearing number marked on seal. Example: RCJ 1 3/16 in. (uses G1103KRRB & Col.)
RCJN, RR Flangette, RRT Flangette	1000KRRB & Col.	Non-relubricatable; B-spherical outer ring; RR-double R-seal	Complete bearing number marked on seal. Example: RCJN 1 3/16 in. (uses 1103KRRB & Col.)
RFC, RCJC, RCJTC	GC1000KRRB & Col.	G-relubricatable; C-concentric collar; B-spherical outer ring; RR-double R-seal	Complete bearing number marked on seal. Example: 1 3/16 in. (uses GC1103KRRB & Col.)
RFD, RFDR, RFTD, RFTDR	1000KRRB & Col.	Non-relubricatable; B-spherical outer ring; RR-double R-seal	Complete bearing number marked on seal. Example: RFD: 1 3/16 in. (uses 1103KRRB & Col.)

Continued on next page.

Continued from previous page.

Mounted Bearings	Replacement Bearing Assembly	Features	Part No.
RKD, RSD	1000KRRB & Col.	Non-relubricatable; B-spherical outer ring; RR-double R-seal	Complete bearing number marked on seal. Example: RKD 1 3/16 in. (uses 1103KRRB & Col.)
RPB	RABR (shaft size)	Non-relubricatable; B-spherical outer ring; RR-double R-seal	RA000RRB FS-450 Bearing and Col. mounted in rubber interliner. Example: RPB 1 3/16 in. (uses an RABR 1 3/16 in.)
RR Relubricatable Flangette	G1000KRRB & Col.	G-relubricatable; B-spherical outer ring; RR-double R-seal	To order, specify bearing and markings. Example: 1-G1100KRRB & Col., 1-G52MSA marking, 1-G52MSB marking
SA	MUB replaced by 1000KRB & Col.	Standard series (SM) wide-inner-ring ball bearing (B-type), collar, caps and wire	Example: SA 1 3/16 in. (uses MUB 1 3/16 in.)
SAD	MUBD replaced by 1000KRB & Col.	Standard series (SM) wide-inner-ring ball bearing (B-type), dust seal, collar, caps and wire	Example: SA 1 3/16 in. (uses MUB 1 3/16 in.)
SADD	MUBD replaced by N000KRB & Col.	Rear dust seal, otherwise same as SAD	
SAL	SM1000KS & Col.	S-external self-aligning ring	Example: SAL 1 3/16 in. (uses SM1103KS & Col.)
SAO	MUOB replaced by 100KRB & Col.	Heavy series (SMN) wide-inner-ring ball bearing (B-type), collar, caps and wire	Example: SAO 1 3/16 in. (uses MUOB 1 3/16 in.)
SAOD	MUOBD (shaft size)	Heavy series (SMN) wide-inner-ring ball bearing (B-type), dust seal, collar, caps and wire	Example: SAOD 1 3/16 in. (uses MUOBD 1 3/16 in.)
SAODD	MUOBD (shaft size)	Rear dust seal, otherwise same as SAOD	
SAOL	SMN000KS & Col.	S-external self-aligning ring heavy series	Example: SAOL 1 3/16 in. (uses SMN103KS & Col.)
SAS, SAK	GYA000RRB	G-relubricatable; B-spherical outer ring; RR-double R-seal	Bearing identification marked on seal.
SCJ, SCJT	GYA000RRB	G-relubricatable; B-spherical outer ring; RR-double R-seal	Bearing identification marked on seal.
TAK, TAS	G1000KPPB & Col.	G-relubricatable; B-spherical outer ring; PP-Double tri-ply seal	Complete bearing number marked on seal. Example: TAK 1 3/16 in. (uses G1103KPPB3 & Col.)
TCJ, TCJT	G1000KPPB & Col.	G-relubricatable; B-spherical outer ring; PP-Double tri-ply seal	Complete bearing number marked on seal. Example: TCJ 1 3/16 in. (uses G1103KPPB3 & Col.)
VAK, VAS	GRA000RRB & Col.	G-relubricatable; B-spherical outer ring; RR-double R-seal	Bearing identification marked on seal.
VCJ, VCJT	GRA000RRB & Col.	G-relubricatable; B-spherical outer ring; RR-double R-seal	Bearing identification marked on seal.
VFD, VFDR, VFTD, VFTDR	RA000RRB & Col.	Non-relubricatable; B-spherical outer ring; RR-double R-seal	Bearing identification marked on seal.
YAS, YAK, YASM, YCJ, YCJT, YTU	GY-KRRB	G-relubricatable; B-spherical outer ring; RR-double R-seal, Y-series wide inner ring	Bearing identification marked on seal.
OTHER TYPES			
LTU Take-Up	G1000KLLB & Col.	G-relubricatable; B-spherical outer ring; LL-double Mechani-seal	Complete bearing number marked on seal. Example: LTU 1 3/16 in. (uses G1103KLLB & Col.)
RHC, RHCM Hanger	GC1000KRRB & Col.	G-relubricatable; C-concentric collar; B-spherical outer ring; RR-double R-seal	Complete bearing number marked on seal. Example: RCH 1 1/2 in. (uses GC1108KRRB & Col.)
RTU Take-Up	G1000KRRB & Col.	G-relubricatable; B-spherical outer ring; RR-double R-seal	Complete bearing number marked on seal. Example: RTU 1 3/16 in. (uses G1103KRRB & Col.)
STU Take-Up	GYA-RRB	G-relubricatable; B-spherical outer ring; RR-double R-seal	Complete bearing number marked on seal. Example: STU 1 3/16 in. (uses GYA103RRB)
TU Take-Up	MUB replaced by 1000KRB & Col.	Standard series (SM) wide-inner-ring ball bearing (B-type), collar, caps and wire	Example: TU 2 11/16 in. (uses MUB 2 11/16 & Col.)
YTU Take-Up	GY-KRRB	G-relubricatable; B-spherical outer ring; RR-double R-seal; Y-series wide inner ring with set screw lock	Complete bearing number marked on seal. Example: YTU 1 3/16 in. (uses GY1103KRRB)

MACHINE UNITS

A complete machine unit consists of either a standard (SM) or heavy (SMN) series wide-inner-ring ball bearing, an inner and outer sealing cap, a retaining wire and self-locking collar, or an integrally sealed bearing and collar. These units are available as bearing replacements for Timken power transmission units such as the SA, SAO, DSA and DSAO pillow blocks, and C and Co cylindrical cartridges or special housings.

These are available in two types, A and B, as described below.

A-TYPE

Fig. 27 shows a machine unit with an A-type bearing carrying the designation MUA (standard series) and MUOA (heavy series). It consists of a wide inner ring, open type or one-piece R-seal bearing, collar, caps and wire. The "caps" are two steel members which comprise a non-integral frictionless labyrinth seal. The inner member is pressed on the inner ring and rotates with it. The outer member is pressed in the housing against the face of the outer ring and is held in place by the round retaining wire.

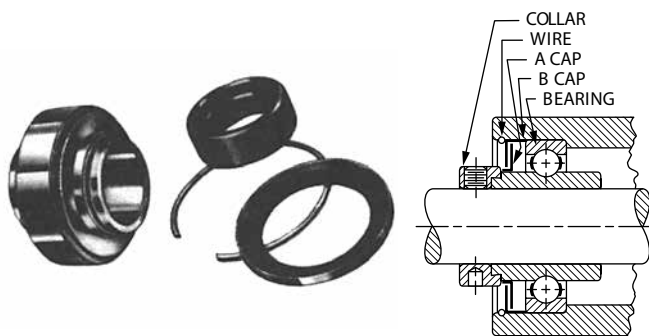

Fig. 27. MUA, MUOA.

B-TYPE

Fig. 28 is the same as fig. 27, except that the bearing is B-type and the seal on the collar side is either a labyrinth seal (as shown) or a one-piece R-seal. In the latter case no wire is supplied. The designation of the machine unit is MUB (standard series) or MUOB (heavy series). The B-type bearing is mounted in the spherical housing seat by means of two slots milled diametrically opposite each other in the housing. The bearing can be inserted at right angles and swiveled into position. No additional shoulders or snap rings are required to locate this type.

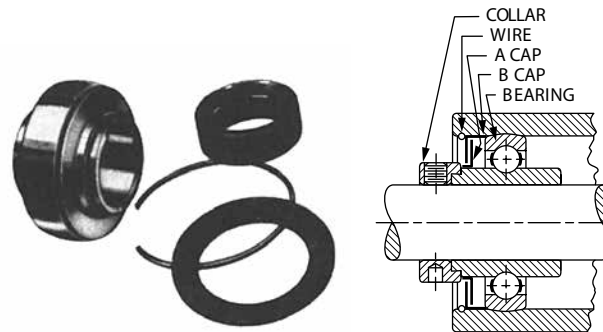

Fig. 28. MUB, MUOB.

TIMKEN® FAFNIR® MOUNTED BALL BEARINGS SAFETY END CAPS MAKE WORKPLACE PROTECTION A SNAP

Easy-to-install Timken® safety end caps protect exposed rotating shafts, reducing hazards around many types of equipment.

The Timken safety product line consists of a mounting ring and snap-on cover, both molded in durable, bright-yellow polymer. The end cap snaps into the adhesive-backed ring that adheres to the outboard face of most flanged bearing housings. The secure 360-degree fit makes for a rugged unit that also provides basic protection and washdown.

Factory retrofits are a snap with everything provided in a handy kit. The cost-effective end covers are simple-to-install on Timken and most other flanged units. Current sizes range from 20 mm to 50 mm (3/4 in. to 1 15/16 in.) shaft sizes for two or four-bolt flanged cast-iron, malleable iron and other selected housing styles and sizes.

KIT CONTENTS

Timken safety end caps come in a convenient kit that contains everything required for a safe and durable mounting:

- Polymer end cap.
- Adhesive-backed polymer mounting ring.
- Scuffing pad.
- Cleaning cloth.

INSTALLATION

Steps in the simple mounting procedure include:

1. Use the scuffing pad on housing's mating surface where the mounting ring will be placed.
2. Clean off the mounting area.
3. Attach the adhesive-backed mounting ring.
4. Hold the mounting ring in place with pressure for 60 seconds.
5. Allow the adhesive to set for a minimum of one hour.
6. Snap the end cap into place.



Fig. 29. Safety end caps protect against rotating stub shafts.

ORDERING INFORMATION

TABLE 27. ORDERING INFORMATION

Kit ⁽¹⁾	Shaft Sizes
204 ECY Kit	20 mm, 3/4
205 ECY Kit	25 mm, 7/8, 15/16, 1
206 ECY Kit	30 mm, 1 1/16, 1 1/8, 1 3/16, 1 1/4 S
207 ECY Kit	35 mm, 1 1/4, 1 5/16, 1 3/8, 1 7/16,
208 ECY Kit	40 mm, 1 1/2
209 ECY Kit	45 mm, 1 5/8, 1 11/16, 1 3/4
210 ECY Kit	50 mm, 1 15/16, 2 S

⁽¹⁾Kits are designed to fit the following mounted bearings –
 Four-bolt: YCJ, RCJ, RCJC, TCJ, LCJ, SCJ, VCJ
 Two-bolt: YCJT, RCJT, RCJTC, TCJT, LCJT, SCJT, VCJT

INDEX

MOUNTED BALL BEARINGS

Mounted Ball Bearings	65	RCJ Series	156
Mounted Ball Bearing Introduction	68	RCJ, TCJ, LCJ Industrial Series	96
DRNR Industrial Series	95	RCJC Industrial-Series Concentric Collar	98
Engineering	5	RCJO, LCJO Heavy Series	103
ER Industrial Series, Relubricatable Types	48	RCJT and RTB Series	152
FLCT Standard Series	111	RCJT Series	157
GC-KRRB Industrial-Series Concentric Collar, Relubricatable Types	42	RCJT, TCJT, LCJT Industrial Series	106
G-KLL, G-KLLB Special Series, Relubricatable Types	39	RCJTC Industrial-Series Concentric Collar	107
G-KRR, G-KRRB Relubricatable Types	36	RCSM, RCR, CR Series	133
GN-KLLB Special Duty	61	Replacement Bearings	162
GN-KRRB Relubricatable Types	59	RFC Industrial Piloted-Series Concentric Collar	112
GRA, GRR Relubricatable Flangette Units	131	Roller Chain Idler Sprockets	161
GRA-RR, GRA-RRB Relubricatable Types	52	RR Flangette Unit	123
GRFD, GRFDR Relubricatable Series – RFD, RFDR Non-Relubricatable Series	115	RSA, LSA Industrial Series	89
GRFTD, GRFTDR Relubricatable Series – RFTD, RFTDR Non-Relubricatable Series	117	RSOA, LSAO Heavy Series	91
GVFD, GVFDR Relubricatable Series – VFD, VFDR Non-Relubricatable Series	114	RTU Industrial Series	137
GVFTD, GVFTDR Relubricatable Series – VFTD, VFTDR Non-Relubricatable Series	116	RTU Series	158
GYA-RR, GYA-RRB Relubricatable Types	56	SAK Standard Series	75
GY-KRRB Set Screw Industrial Series	46	SAL Industrial Series, Fixed and Floating Types	92
GYM-KRRB Inserts Set Screw Lock	58	SAOL Heavy Series, Fixed and Floating Types	93
Idler Pulley Units	159	SAS Standard Series	81
KAK/S Series	142	SCJ Standard Series	102
KCJ Series	143	SCJT Standard Series	110
KCJT and KTB Series	144	SM Industrial Series A and B Types/MUA-B Inserts	43
KL, KLB, KLL, KLLB Special Series, Non-Relubricatable Types	38	SMN A and B Types/MUOA-B Inserts	62
KLLG Special Series With Wireloc®	40	SMN-S Series	64
KR, KRR, KRRB Non-Relubricatable Types	34	SM-S Industrial Series	45
LFST Series	122	STB Series	85
Machine Units	164	Timken® Fafnir® Mounted Ball Bearings Safety End Caps	
NLTU Series Side-Mounted, Pressed-Steel	135	Make Workplace Protection a Snap	165
PB Series – RPB Series	119	Tri-ply Seal Industrial Series, Non-Relubricatable and Relubricatable Types	41
PBS Series	118	TTU Industrial Series	140
Pressed-Steel Flanged Units	121	TU Series Top-Mounted Cast-Iron	136
Pressed-Steel Flangette Units	123	VAK Standard Series	74
Pressed-Steel Mounted Bearings	118	VAS Standard Series	80
RA Flangette Unit	125	VCJ Standard Series	101
RABR HVAC Special Series	134	VCJT Standard Series	108
RA-DD Non-Relubricatable Types	54	VFMST Series	121
RAK, TAK, LAK Industrial Series	71	VTB Series	87
RAK/S Series	150	VTU Standard Series	139
RAK/S Series	155	Wide-Inner-Ring Ball Bearing Introduction	27
RAKH Industrial Series	82	YAK Industrial-Series Set Screw Units	73
RAKHL Expansion Series	83	YAK/S Series	146
RAL-NPPB Non-Relubricatable Types	57	YA-RR, YA-RRB Non-Relubricatable Types	55
RAO, LAO Heavy Series	88	YAS Industrial-Series Set Screw Units	79
RA-RR, RA-RRB Non-Relubricatable Types	50	YASM Medium-Duty Series Set Screw Lock	84
RAS, TAS, LAS Industrial Series	76	YCJ and YCJT Series	154
RASC Industrial-Series Concentric Collar	78	YCJ Industrial Set Screw Series	99
RAT, RRT Two-Bolt Flangette Units	127	YCJ Series	147
RATR, RRTR Triangle Flangette Units	129	YCJKM Medium-Duty Series Set Screw Lock	104
RC Series	113	YCJT Industrial Set Screw Series	109
RCJ Series	151	YCJT Series	148
		YCYJM Medium-Duty Series Set Screw Lock	105
		YTB Series	86
		YTB and YFB Series	149
		YTU Industrial Series	138



To view more Timken catalogs, go to www.timken.com/catalogs for interactive versions, or to download a catalog app for your smart phone or mobile device scan the QR code or go to timkencatalogs.squawqr.com.

TIMKEN

The Timken team applies their know-how to improve the reliability and performance of machinery in diverse markets worldwide. The company designs, makes and markets bearings, gear drives, automated lubrication systems, belts, brakes, clutches, chain, couplings, linear motion products and related industrial motion rebuild and repair services.

Price: USD \$75

Stronger. By Design.

www.timken.com