

# TIMKEN



**TIMKEN® FAFNIR® SUPER PRECISION BEARINGS FOR MACHINE TOOL APPLICATIONS CATALOG**



## ABOUT THE TIMKEN COMPANY

As a global leader in bearings and industrial motion systems, Timken focuses on precise solution design, materials and craftsmanship to deliver reliable and efficient performance that improves productivity and uptime. Timken offers a full range of bearings, belts, chains, couplings, gears and lubricants, along with rebuild and repair services.

Timken (NYSE: TKR; [www.timken.com](http://www.timken.com)) applies its proven expertise in metallurgy, tribology and industrial motion to create innovative approaches to customers' complex needs. Global availability of products and engineering talent, combined with exceptional service delivery across markets, makes Timken a preferred choice worldwide.

To view more Timken catalogs, go to [www.timken.com/catalogs](http://www.timken.com/catalogs) for interactive versions, or to download our catalog app to your smart phone or mobile device.



## TIMKEN® FAFNIR® SUPER PRECISION BEARINGS FOR MACHINE TOOL APPLICATIONS CATALOG INDEX

INTRODUCTION .....	2
SHELF LIFE AND STORAGE .....	3
WARNINGS.....	4

### ENGINEERING

Bearing Selection Process .....	6
Applied Loads and Bearing Analysis .....	25
Bearing Life and System Life .....	36
Permissible Operating Speed and Lubrication .....	42
Run-In Procedures .....	51
Heat Generation and Dissipation .....	54
Tolerances .....	57
Fitting Practices.....	72
Shaft And Housing Considerations.....	82
Mounting Designs .....	86
Setting And Preloading Guidelines.....	94

### PRECISION TAPERED ROLLER BEARINGS

Nomenclature .....	98
Introduction .....	102
Bearing Types .....	102
TS Style – Metric, Inch .....	104
TSF Style – Metric, Inch .....	108
TXR Style – Metric, Inch.....	112
TSHR Style – Metric, Inch .....	114
Tapered Roller Bearing Bore Diameters Found In This Catalog .....	118

### SUPER PRECISION BALL BEARINGS

Nomenclature .....	120
Bearing Types.....	125
Applications .....	128
Spindle Bearings .....	132
Ball Screw Support Bearings .....	194
Ex-Cell-O Spindle Bearings .....	212
Ball Bearing Bore Diameters Found In This Catalog.....	214

### APPENDIX

Frequency Coefficients.....	216
Precision Tag Deviation and Runout Charts .....	233
Geometry Factors .....	235
Radial Internal Clearance .....	237
Bearing Locknuts and Torque .....	238
Lubrication Specifications.....	240
Operating Temperatures for Bearing Component Materials .....	242
Conversion Tables .....	244

INDEX.....	245
------------	-----

## SETTING THE STANDARD

Our products and services set the standard in high-speed spindles, ball screws, rotary tables and other demanding applications. Our portfolio includes specialized tapered roller and ball bearings produced to precision classes that deliver operating characteristics necessary for the highest performance.

Timken® bearings meet or exceed application needs for rotational accuracy, consistency and rigidity. Longer bearing service life translates to more machine uptime and production.

## PRODUCT BREADTH

Brands like Timken® and Fafnir® reflect an extensive line of tapered, spherical, cylindrical, ball bearings and mounted units for virtually every machine tool and industrial application. We can offer the right bearing for almost any machine position.

## TAPERED ROLLER BEARINGS

Timken® tapered roller bearings have been used for many years in machine tool applications due to their widely recognized advantages in stiffness, load-carrying capacity, precision and reliability over other bearing designs.

As applications have achieved much higher cutting speeds, Timken has maintained the same global accuracy level by developing optimum spindle designs through special internal bearing geometry and innovative bearing designs.

## BALL BEARINGS

Ultra-precision equipment requires more than standard bearings can deliver. Timken super precision ball bearings meet the highest industry standards in tolerance levels (including ABEC 9). Designed for machine tool applications, our precision ball bearings offer superior tolerance and performance.

## ANGULAR CONTACT BEARINGS

Timken® Fafnir® angular contact ball bearings are manufactured to provide a high degree of rigidity in both axial and radial directions while operating at minimum temperatures for a wide range of speeds and operating loads, leading to more accurate work at a higher production rate.

Our angular contact ball bearings give the machine builder the flexibility required to meet speed and load variations in machine tool applications.

## BALL SCREW SUPPORT BEARINGS

Ball screw support bearings with steep contact angles, available in single row, or in housed units, provide high levels of stiffness and simplified installation for the demands of servo-controlled machinery.

## ASSEMBLE-TO-ORDER PROGRAM

Our premium customer service is leveraged by our global sales and distribution network. The Assemble-To-Order Program can perform cost-effective quick delivery of a variety of machine tool ball bearings for product not easily found at local distribution centers.

## HOW TO USE THIS CATALOG

We designed this catalog to help you find the Timken bearings best suited to your equipment needs and specifications.

This publication contains dimensions, tolerances and load ratings, as well as engineering sections describing fitting practices for shafts and housings, internal clearances and other bearing features. For more information, please use the Timken Engineering Manual (order no. 10424). It provides valuable assistance in the initial consideration of the type and characteristics of the bearings that may best suit your particular needs.





## SHELF LIFE AND STORAGE OF GREASE-LUBRICATED BEARINGS AND COMPONENTS

To help you get the most value from our products, Timken provides guidelines for the shelf life of grease-lubricated ball and roller bearings, components and assemblies. Shelf life information is based on Timken and industry test data and experience.

### SHELF LIFE

Shelf life should be distinguished from lubricated bearing component design life as follows:

Shelf life of the grease-lubricated bearing/component represents the period of time prior to use or installation.

The shelf life is a portion of the anticipated aggregate design life. It is impossible to accurately predict design life due to variations in lubricant bleed rates, oil migration, operating conditions, installation conditions, temperature, humidity and extended storage.

**TIMKEN IS NOT RESPONSIBLE FOR THE SHELF LIFE OF ANY BEARING/COMPONENT LUBRICATED BY ANOTHER PARTY.**

### European REACH compliance

Timken lubricants, greases and similar products sold in stand alone containers or delivery systems are subject to the European REACH (Registration, Evaluation, Authorization and Restriction of Chemicals) directive. For import into the European Union, Timken can sell and provide only those lubricants and greases that are registered with ECHA (European Chemicals Agency). For further information, please contact your Timken engineer.

### STORAGE

Timken suggests the following storage guidelines for our finished products (bearings, components and assemblies, referred to as "products"):

- Unless directed otherwise by Timken, products should be kept in their original packaging until they are ready to be placed into service.
- Do not remove or alter any labels or stencil markings on the packaging.
- Products should be stored in such a way that the packaging is not pierced, crushed or otherwise damaged.

- After a product is removed from its packaging, it should be placed into service as soon as possible.
- When removing a product that is not individually packaged from a bulk pack container, the container should be resealed immediately after the product is removed.
- Do not use product that has exceeded its shelf life as defined in the Timken shelf life guidelines statement.
- The storage area temperature should be maintained between 0° C (32° F) and 40° C (104° F); temperature fluctuations should be minimized.
- The relative humidity should be maintained below 60 percent and the surfaces should be dry.
- The storage area should be kept free from airborne contaminants such as, but not limited to, dust, dirt, harmful vapors, etc.
- The storage area should be isolated from undue vibration.
- Extreme conditions of any kind should be avoided.

Due to the fact that Timken is not familiar with your particular storage conditions, we strongly suggest following these guidelines. However, you may be required by circumstances or applicable government requirements to adhere to stricter storage requirements.

Most bearing components typically ship protected with a corrosion-preventive compound that is not a lubricant. These components may be used in oil-lubricated applications without removal of the corrosion-preventive compound. When using some specialized grease lubrications, we advise you to remove the corrosion-preventive compound before packing the bearing components with suitable grease.

Be careful in selecting lubrication, however, since different lubricants are often incompatible.

When you receive a bearing shipment, do not remove products from their packaging until they are ready for mounting so they do not become corroded or contaminated.

Store bearings and bearing housings in an appropriate atmosphere so they remain protected for the intended period.



**WARNING**

***Failure to observe the following warnings could create a risk of death or serious injury.***

Proper maintenance and handling practices are critical. Always follow installation instructions and maintain proper lubrication.

Overheated bearings can ignite explosive atmospheres. Special care must be taken to properly select, install, maintain, and lubricate housed unit bearings that are used in or near atmospheres that may contain explosive levels of combustible gases or accumulations of dust such as grain, coal, or other combustible materials.

Never spin a bearing with compressed air. The components may be forcefully expelled.

A bearing/component should not be put into service if its shelf life has exceeded.

Tensile stresses can be very high in tightly fitted bearing components. Attempting to remove such components by cutting the cone (inner race) may result in a sudden shattering of the component causing fragments of metal to be forcefully expelled. Always use properly guarded presses or bearing pullers to remove bearings from shafts, and always use suitable personal protective equipment, including safety glasses.

**CAUTION**

***Failure to follow these cautions may result in property damage.***

Do not use damaged housed units.

When fitting the inner ring there should be an equal gap at each joint. If there are no gaps do not proceed.

The products catalogued are application specific. Any use in applications other than those intended could lead to equipment failure or to reduced equipment life.

Use of improper bearing fits may cause damage to the equipment.

Do not use damaged bearings. The use of a damaged bearing can result in equipment damage.

**NOTE**

*Do not use excessive force when mounting or dismantling the unit.*

*Follow all tolerance, fit, and torque recommendations.*

*Ensure proper alignment.*

*Never weld housed units.*

*Do not heat components with an open flame.*

*Do not operate at bearing temperatures above 121° C (250° F).*

*Never interchange components between completed bearing assemblies.*

*Never use a hammer and steel bar on a bearing for installation or removal. Use only a brass bar or a soft-headed mallet.*

*Consult your equipment designer or supplier for installation and maintenance instructions.*

*Never use steam or hot water when cleaning the bearings because these methods can create rust or corrosion.*

*Never expose any surface of a bearing to the flame of a torch.*

*Do not heat bearing beyond 149°C (300°F).*

*Product performance is affected by many factors beyond the control of Timken. Therefore, the suitability and feasibility of all designs and product selection should be validated by you. This catalog is provided solely to give you, a customer of Timken or its parent or affiliates, analysis tools and data to assist you in your design.*

*No warranty, expressed or implied, including any warranty of merchantability or fitness for a particular purpose, is made by Timken. Timken products are sold subject to a Limited Warranty.*

*Every reasonable effort has been made to ensure the accuracy of the information contained in this catalog, but no liability is accepted for errors, omissions or for any other reason.*

**DISCLAIMER**

***This catalog is provided solely to give you analysis tools and data to assist you in your product selection. Product performance is affected by many factors beyond the control of Timken. Therefore, you must validate the suitability and feasibility of all product selections.***

***Timken products are sold subject to the Timken terms and Conditions of Sale, which include our limited warranty and remedy. You can find these at <https://www.timken.com/legal/notices/termsandconditionsofsale/>.***

***Please consult with your Timken engineer for more information and assistance. Every reasonable effort has been made to ensure the accuracy of the information in this writing, but no liability is accepted for errors, omissions or for any other reason.***

***Warnings for this product line are in this catalog and posted on <http://www.timken.com/legal-notices/>***



## **ENGINEERING**

The following topics are covered within this section:

Bearing Selection Process . . . . .	6
Applied Loads and Bearing Analysis . . . . .	25
Bearing Life and System Life . . . . .	36
Permissible Operating Speed and Lubrication . . . . .	42
Run-In Procedures . . . . .	51
Heat Generation and Dissipation . . . . .	54
Tolerances . . . . .	57
Fitting Practices . . . . .	72
Shaft And Housing Considerations . . . . .	82
Mounting Designs . . . . .	86
Setting And Preloading Guidelines . . . . .	94

This engineering section is not intended to be comprehensive, but does serve as a useful guide in bearing selection.



To view more Timken catalogs, go to **[www.timken.com/catalogs](http://www.timken.com/catalogs)** for interactive versions, or to download a catalog app for your smart phone or mobile device scan the QR code or go to **[timkencatalogs.squawqr.com](http://timkencatalogs.squawqr.com)**.

## BEARING SELECTION PROCESS TIMKEN® SUPER PRECISION BEARINGS

Manufacturers require machine tools that are extremely accurate, reliable and capable of high levels of productivity. A major contribution to the performance of any machine tool is supplied by the rolling bearings used to support the spindles, rotating tables, ball screws and other critical precision positions. A manufactured bearing's precision level has a major influence on the ability to perform in high-speed applications commonly seen in factory machining environments.

### WHICH TYPE OF TIMKEN BEARING IS MOST APPROPRIATE FOR YOUR MACHINE TOOL APPLICATION?

To achieve the highest possible performance precision level, the majority of machine tool-related bearing applications must address four primary requirements: speed, stiffness, accuracy and load capacity.

#### Speed

Today's industrial machining environments stress maximum production rates. To reach these high metal-removal goals, machines are operating at maximum speeds with working spindles tuned to provide premium running accuracy.

Achievable spindle rotating speeds require management of heat generation within the bearing assembly. The bearing's ability to not only minimize heat buildup, but also expel excess heat, is a crucial consideration in the bearing selection process. Because of the differences in rolling element contact geometry, ball bearings are superior in minimizing heat generation, especially where higher speeds are desired.

Fig. 1 compares the relative maximum speed of similar cross section ball and tapered roller bearings (both using synthetic grease as a baseline lubricant). Therefore, in applications where higher RPM levels are the primary concern, ball bearings have a distinct advantage.

Bearings must be carefully designed to minimize heat generation and vibration to enable high speeds. Specific strategies include overall bearing configuration, precision internal geometry and material selection. Optimizing bearing ring and shoulder construction with the ball complement supports higher speed performance. Engineering raceway and ball geometry helps to minimize friction, while ceramic rolling elements generate less heat with reduced skidding.

To prevent vibration at high speeds, close bearing tolerances are required. Timken® machine tool bearings are designed to meet or exceed industry tolerance standards and deliver smooth running performance.

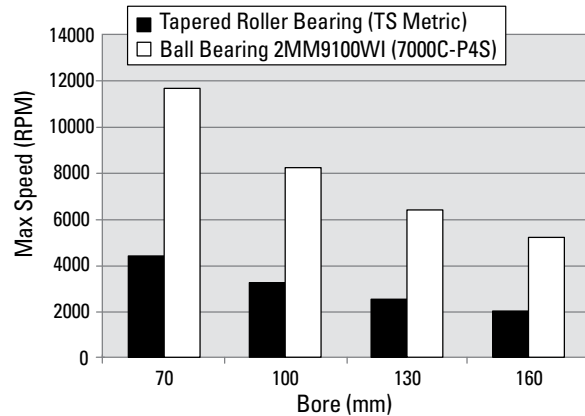

Fig. 1. Tapered roller bearing vs. ball bearing maximum permissible speed (with synthetic high-speed grease).

In addition to the use of hybrid ceramic technology, further enhancements in speed, as well as control of bearing noise and temperature, can be achieved through cage design or material, and choice of lubrication.

Many of the factors that allow for maximum speed have been designed into Timken's HX series of super precision ball bearings. Engineered for the reduction of friction and minimum heat buildup, this series features unique ball complements and precision-engineered surface geometries. Options for further enhancing speed include the use of low weight ceramic rolling elements, lubrication designed for high speed, and lighter preload levels. These are discussed in further detail later in this catalog.

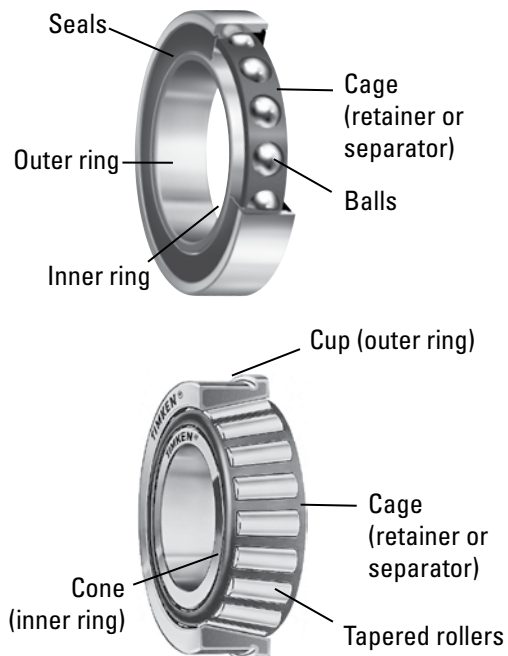

Fig. 2. Bearing components.

### Stiffness

The ability to minimize tool deflection experienced under cutting loads is vital to achieving the accuracy needed to produce finished parts within specified tolerances. Less variance produces better quality and helps keep product scrap levels at a minimum. Bearings have a significant effect on spindle stiffness, due to their deflection under applied load. Because of their internal geometry and rolling element type, tapered roller bearings provide considerably higher stiffness levels as shown in Fig. 3 and 4.

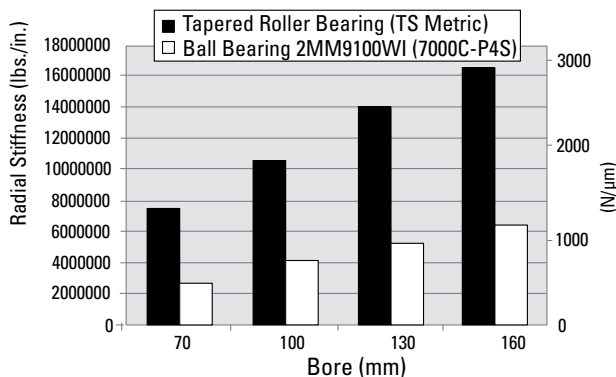

Fig. 3. Tapered roller bearing vs. ball bearing radial stiffness.

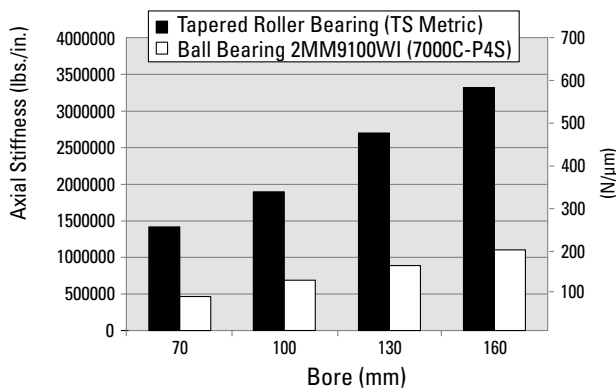

Fig. 4. Tapered roller bearing vs. ball bearing axial stiffness.

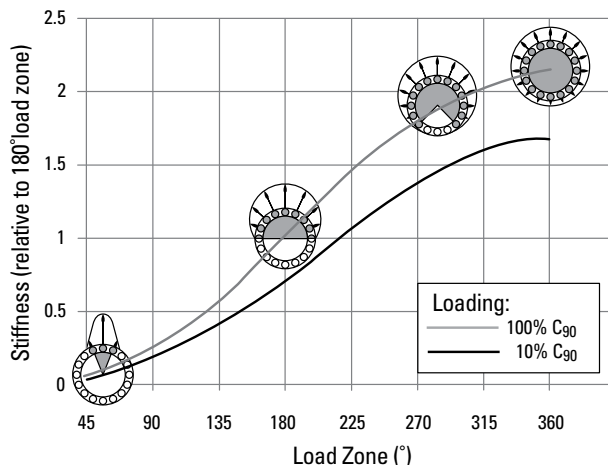

Fig. 5. Effect of load zone on bearing stiffness.

Bearing stiffness also depends on design load zone, which is directly related to bearing setting, clearances and applied loads. (Setting is defined as a specific amount of either end play or preload.)<sup>(1)</sup> A bearing under radial load with zero end play/zero preload has a load zone close to 180 degrees, while a bearing with preload can reach 360 degrees load zone. Fig. 5 shows the effect of load zone on tapered roller bearing stiffness. The curves demonstrate that while the effect of external loads on stiffness is important, the impact from setting is more significant.

Since thermal expansion can dramatically affect preload or setting, it can also play a very important role in the resulting static and dynamic stiffness of a spindle system. This applies to ball bearings as well.

An inherent advantage of the tapered roller bearing is that it can be adjusted after mounting. This means that the optimum stiffness can be obtained either by determining the proper setting during the mounting phase for a simple bearing arrangement, or during running by the use of a “variable preload” bearing design such as Timken® Hydra-Rib™ and Spring-Rib™ bearings.

To better manage the load sharing of the set of rolling elements, Timken offers a variety of designed-in preload levels for ball bearings. Be conservative with the addition of preloading as these forces will contribute to heat generation, reducing the maximum permissible speed of either ball or tapered roller bearing designs.

<sup>(1)</sup>For additional information, see guidelines on page 94.



### Accuracy

Another key factor in the machine’s precision is the runout (rotational accuracy) of the bearing. This affects the geometry and surface finish of the target workpiece. For the ultimate accuracy and repeatability of machine tool motion, Timken® super precision ball bearings offer the best control, with quietness of operation and reduced vibration. To achieve the highest level of precision with increased stiffness and load capacity, multiple ball bearings may be used in sets specifically designed for this purpose.

The most widely recognized definition of quality is contained within the ABEC/ISO classes; however some factors affecting performance of a bearing are not completely defined within these standards. This allows for a significant range of variability in product performance among bearing manufacturers. To provide premium performance, all Timken ball bearing MV(P4), MM/MMV(P4S) and MMX(P2) precision grades comply with strict controls over these non-specified parameters – all of which can have a direct impact on the service life and performance of a bearing.

**TABLE 1.  
PRECISION BEARING CLASSES**

Tapered Roller Bearings - Precision Class				
Timken Metric	C	B	A	AA
Timken Inch	3	0	00	000
ISO/DIN	P5	P4	P2	-
ABMA Metric	C	B	A	-
ABMA Inch	3	0	00	-

Ball Bearings - Precision Class				
Timken FAFNIR	V	MV	MM/MMV	MMX
Timken ISO	P5	P4	P4S	P2
ISO/DIN	P5	P4	-	P2
ABMA	ABEC 5	ABEC 7	-	ABEC 9

Crossed Tapered - Precision Class		
Timken Metric	S	P
Timken Inch	3	0

### High Precision Ball Bearings (ABEC 7; ISO P4)

Timken high precision ball bearings manufactured to the MV (P4) tolerance class operate with running accuracy, performance levels and dimensional controls conforming to ABEC 7 (ISO P4) tolerances. These bearings are the right choice for applications where both precision and cost effectiveness drive the selection.

### Super Precision Ball Bearings, Super High Precision (ABEC 7/9; ISO P4/P2)

Timken super precision ball bearings manufactured to the MM/MMV(P4S) tolerance class operate with running accuracy and performance levels meeting ABEC 9 (ISO P2) standards yet maintain other features at ABEC 7 (ISO P4) level for cost-effectiveness. Bore and O.D. surfaces are coded in micron units for the convenience of the discriminating machine tool builder striving for optimum fitting of crucial spindle components.

### Ultra-Precision Ball Bearings (ABEC 9, ISO P2)

Timken MMX(P2) super precision ball bearings, with closer tolerances and running accuracies than ABEC 7 (ISO P4) bearings, are made to ABEC 9 (ISO P2) tolerances. Bearings produced to these tolerances are generally used on ultra-high-speed grinding spindles designed for tight dimensional tolerances and superfine surface finishes. Contact your Timken representative for availability of product range.

### Precision Tapered Roller Bearings (Class C/S/3, B/P/0 and A/00)

The more demanding the precision objective, the more accurate the bearing must be. Timken provides three tapered roller bearing classes, in both metric and inch systems, that cover the full range of precision application requirements. In ascending order of accuracy, they are identified in the metric system as Class C/S, B/P, and A, while in the inch system as Class 3, 0, and 00.

### Precision Plus™ Tapered Roller Bearings (Class 000/AA)

To further minimize the influence of variations, Timken offers a fourth level of precision tapered roller bearing manufacture so tightly controlled that it goes beyond the grade levels of both ISO and ABMA standards. Timken’s Precision Plus™ line offers (metric-nominal) AA level and (inch-nominal) 000 tapered roller bearings in various sizes and styles.

Timken's MV (P4) and MMV (P4S) bearings are micron coded for the best possible fit up with the shaft and housing in the application. Even though these bearings conform to MV (P4) precision dimensionally, allowing for a lenient tolerance spread, micron coding ensures that the bearing combinations in a set are made so that the bores and outer diameters do not vary by more than 2µm from bearing to bearing.

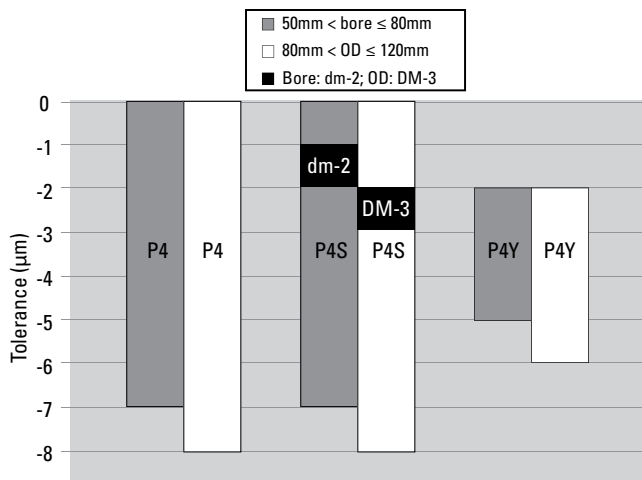

Fig. 6. Tolerance spreads of a bearing with a bore micron code of dm-2 and an O.D. micron code of DM-3.

TABLE 2.  
TYPICAL PRECISION CLASSES FOR COMMON  
MACHINE TOOL BEARING APPLICATIONS

Class MV(P4)	<ul style="list-style-type: none"> <li>• Live tools</li> <li>• Slab milling machines</li> <li>• Textile spindles</li> </ul>
Class MM/MMV(P4S)	<ul style="list-style-type: none"> <li>• High-speed motorized routers</li> <li>• Precision milling/boring machines</li> <li>• Super precision lathes</li> <li>• Precision surface grinding machines</li> </ul>
Class C or 3	<ul style="list-style-type: none"> <li>• Low precision machines</li> <li>• Drilling machines</li> <li>• Conventional lathes</li> <li>• Milling machines</li> <li>• Precision gear drives</li> </ul>
Class B or 0	<ul style="list-style-type: none"> <li>• NC lathes</li> <li>• Milling/boring machines</li> <li>• Machining centers</li> </ul>
Class MMX(P2)	<ul style="list-style-type: none"> <li>• Ultra-precision grinding machines</li> <li>• Ball screws</li> </ul>
Class A or 00	<ul style="list-style-type: none"> <li>• Grinding machines</li> <li>• Jig boring machines</li> <li>• Workpiece spindles (of cylindrical grinders)</li> </ul>
Class AA or 000	<ul style="list-style-type: none"> <li>• High accuracy machines</li> <li>• Precision measuring instruments</li> <li>• Special applications</li> </ul>

Timken engineers have at their disposal vast resources of engineering data and application information to select the right bearing class and tune the critical components so that the machine tool achieves its performance objectives. The adjacent table can be considered as a general guideline for common machine tool bearing applications.

## LOAD CAPACITY

Some machining centers, such as rough grinding operations, are strategically designed for higher material removal rates. The need for aggressive feed rates requires higher load-carrying capacities. These loads can be properly distributed among the rolling elements by providing a permanent force called "preload" or "setting." Preload is the strategic removal of radial play within the bearing to ensure proper rolling element contact on both the inner and outer race. While Timken posts its load capacities in the product tables within this catalog, many applications often approach only a fraction of those limits. For example, workpiece finish may determine the feed rates needed in an application, thereby decreasing the importance of bearing capacity.

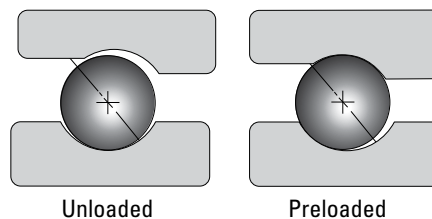

Fig. 7. Effect of preloading on ball bearing raceway contact.

Fig. 8 compares the levels of static capacity of ball vs. tapered roller bearings for the benefit of contrasting basic load capability of both bearing types.

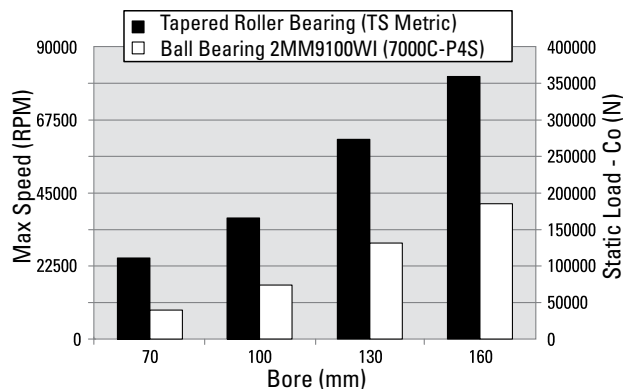

Fig. 8. Tapered roller bearing vs. ball bearing static capacities.

Consult the topics in this section addressing static and dynamic load capacity for more detailed information regarding ball bearings and tapered roller bearings to refine your choice.

Timken can assist in the final bearing selection to help you achieve your precision machining production goals. Timken's staff of application engineers is ready to put its vast experience to any test for assisting our customers with the challenging bearing applications commonly found in the machine tool industry. To refine your search, please turn to the sections covering tapered roller bearings or ball bearings for more information needed to obtain a complete Timken part number specification.

## TIMKEN® MACHINE TOOL BEARING DESIGN

From this introductory discussion and the additional technical content within this catalog, one can obtain an indication of which rolling bearing type should be further investigated to meet the given set of boundary conditions and performance expectations.

### TIMKEN® PRECISION TAPERED ROLLER BEARINGS

The fundamental design principles of the tapered roller bearing make it an ideal solution for low-speed/high-load or low-speed/high-stiffness requirements of machine tool applications.

#### True Rolling Motion

The angled raceways of a tapered roller bearing enable it to carry combinations of radial and axial loads. True rolling motion of the rollers and line contact on the race allow the bearing to run cooler and improve spindle stiffness and accuracy as compared to other roller bearing types. The true rolling motion is the result of two design features: the taper of the roller and the contact between the spherical surface ground on the large end of the rollers and the race rib. The rollers are designed so extensions of the lines along the roller body converge toward the centerline of the bearing and meet at an apex on this centerline (Fig. 9). As a result, there is no relative slip between the rollers and races.

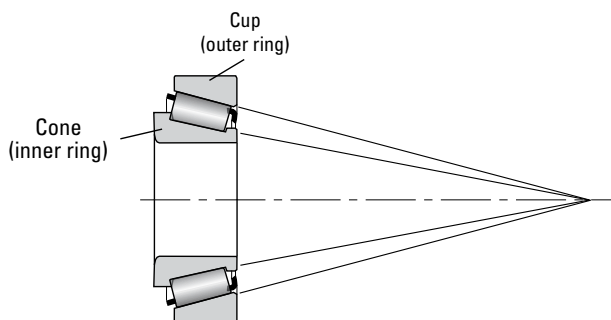

**Fig. 9. On-apex design results in true rolling motion at all points along the roller body.**

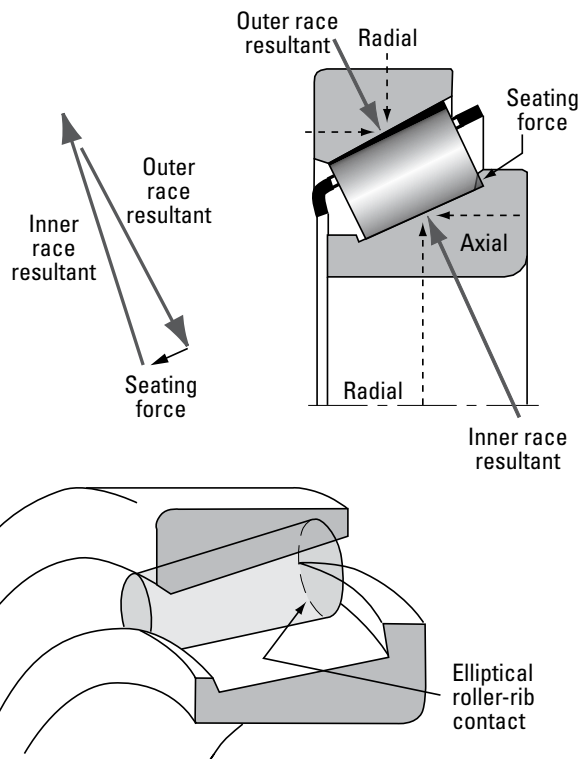

**Fig. 10. Small seating force from the inner race rib keeps rollers aligned on the raceway.**

The tapered configuration of the roller not only ensures that the surface speeds of the rollers and races match at every point along the roller body, but also generates a seating force that pushes the rollers' spherical ends against the race rib. This desirable seating force is a function of the different angles of the outer and inner races (Fig. 10) and prevents rollers from skewing off apex. No skew means positive roller alignment, thereby enhancing bearing life, stiffness and accuracy.

Some applications require a level of precision that cannot be achieved with standard tapered roller bearings. Timken® precision tapered roller bearings promote and maintain the operating accuracy required of today's machine tool industry and various related, specialized markets. Precision class tapered roller bearings offer machine tool builders an economical design solution that exceeds most application needs for rotational accuracy and rigidity.

## PRECISION CLASSES

Timken's high-precision tapered roller bearings consist of carefully matched components that offer an added degree of fine-tuning in the bearing setting and adjustment procedure to maximize customer machine productivity. Timken manufactures high-speed designs with a variable preload capability for optimum machining and Precision Plus bearings – having an overall radial runout less than a single micron.

The application of precision tapered roller bearings is not limited to machine tools. Wherever spindles turn and rotational accuracy is essential to the machine's performance, precision tapered roller bearings can be an excellent choice. Other typical applications are printing presses, optical grinders, profile cutters, indexing tables, precision drives, measuring gauges and ball screw drive applications.

To better serve the global machine tool market, Timken has manufacturing resources around the world focused exclusively on premium precision bearings. With these dedicated resources, precision quality is built into the bearing during manufacturing. To further increase service reliability, Timken precision tapered roller bearings are manufactured from high-quality steel alloys.

## Precision Tapered Roller Bearing Types

The size range of Timken precision tapered roller bearings starts from less than 20.000 mm (0.7874 in.) bore and extends to more than 2000.000 mm (78.7402 in.) O.D., depending on bearing type. The most popular types made in precision classes are the single-row TS and flanged TSF. Comprised of two main separable parts, they are usually fitted as one of an opposing pair. These bearing types are supported by a range of special bearings which have been designed for machine tool applications, such as the variable preload Hydra-Rib bearing, the high-speed TSMA bearing, and the compact TXR crossed roller bearing, which is available only in precision classes. Timken also offers a selection of two-row precision tapered roller bearings types such as the double outer ring type TDO.

### Crossed Roller Bearings

A crossed roller (TXR) bearing is comprised of two sets of bearing races and rollers brought together at right angles to each other, with alternate rollers facing opposite directions, within a section height not much greater than that of a single-row bearing. Also, the steep-angle, tapered geometry of the bearing causes the load-carrying center of each of the races to be projected along the axis, resulting in a total effective bearing spread many times greater than the width of the bearing itself.

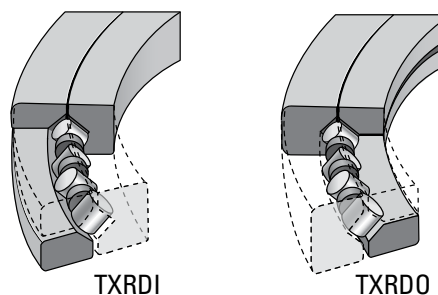

Fig. 11. TXRDI and TXRDO.

Because of the ability of the crossed roller bearing to withstand high overturning moments, it is ideal for the table bearing of machine tools such as vertical boring and grinding machines. This bearing also is well-suited for other pivot and pedestal applications where space is limited or the lowest possible center of gravity of a rotating mass is required.

Crossed roller bearings are available in two precision classes:

- Metric system Class S and P.
- Inch system Class 3 and 0.

The most common form of the bearing is type TXRDO, which has a double outer race and two inner races, with rollers spaced by separators.

Other mounting configurations and sizes of crossed roller bearings can be supplied to meet particular assembly or setting requirements. Please contact your Timken representative for further information. Also, refer to Section B for more details.

### Hydra-Rib™ Bearings

Experience has demonstrated that by optimizing the design parameters of bearing geometry, spindle diameter, bearing spread, lubrication system and mounting, the two single-row bearing layout provides good results over a range of speeds and power. However, for very wide variations of speed and load, the variable preload Timken Hydra-Rib bearing concept is an excellent solution.

The Hydra-Rib bearing (Fig. 12 on the following page) has a floating outer ring rib in contact with the large roller ends instead of the usual fixed inner ring rib. This floating rib operates within a sealed cavity at a given pressure controlled by an appropriate hydraulic or pneumatic pressure system. Changing the pressure consequently changes the preload in the bearing system.



**Fig. 12. Exploded view of a typical Hydra-Rib™ bearing.**

The controlled pressure enables the floating rib to maintain constant spindle preload even though differential thermal expansion occurs in the spindle system during the working cycle. By changing the pressure, a variable preload setting can readily be achieved. This unique bearing concept allows the operator to control any machining condition by simply changing the pressure to optimize the dynamic stiffness and damping characteristics of the spindle. Furthermore, the hydraulic or pneumatic pressure control system can easily be monitored by the numerical control of the machine. In the case of oil pressure control, the hydraulic circuit of the machine can be used.

Your Timken representative should be consulted to determine the optimum bearing selection as well as the pressure figures, as a function of the given running conditions.

## TIMKEN® SUPER PRECISION BALL BEARINGS

The Timken line of super precision machine tool bearings includes bearings designed to meet ABEC7 (ISO P4) and ABEC 7/9 (ISO P4/P2) tolerance levels. However, Timken manufactures all super precision ball bearings to surpass ISO/ABMA criteria to ensure that the end users receive only the highest quality product to maximize machine performance.

Spindle bearings are the most popular type of super precision ball bearing used within the machine tool industry. These angular contact bearings are used primarily in precision, high-speed machine tool spindles. Timken manufactures super precision machine tool bearings in four metric ISO dimensional series. In addition, because of specialized variations of bearing design and geometry, Timken offers a total of seven angular contact bearing types within these four basic series:

- ISO 19 (9300WI/71900, 9300HX/HX71900 series)
- ISO 10 (9100WI/7000, 9100HX/HX7000, 99100WN/WN7000 series)
- ISO 02 (200WI/7200 series)
- ISO 03 (300WI/7300 series)

Multiple internal geometries are available to optimize either load-carrying capacity or speed capability: WI, WN, HX or K. WI-type bearings are designed to maximize capacity of the various bearing cross sections and are used in low to moderate speeds. The HX is Timken's proven high-speed design. It has a significant advantage at higher speeds, generating less heat and less centrifugal loading forces. The WN-type is generally a compromise between the WI and HX as it offers higher speed capability than the WI, but lower capacity and higher stiffness than the HX design, with lower speed capability.

Most of the bearing types are available in either 15 degree (2/C) or 25 degree (3/E) contact angles. In addition, Timken now stocks more ceramic ball sizes than ever for the highest speed requirements.

The K-type deep-groove (Conrad) super precision radial bearing is generally used in applications where capacity and stiffness do not require sets containing multiple bearings. By virtue of the single-row, radial deep-groove construction, and super precision level tolerances, these are capable of carrying thrust loads in either direction, and have a relatively high-speed capability – especially if a light axial preload is applied. Timken offers deep-groove super precision radial machine tool bearings in the following ISO dimensional series:

- ISO 10 (9100K/6000 series)
- ISO 02 (200K/6200 series)
- ISO 03 (300K/6300 series)

## Ball Screw Support Bearings

To meet the demands of the servo-controlled machinery field, Timken® ball screw support bearings are specially designed with steep contact angles and provide high levels of stiffness for ball screw application requirements. Timken's series of double-row, sealed, flanged (or cartridge) units use an integral double-row outer ring to help simplify installation procedures. Timken offers the following ball screw support bearing products:

- Inch series bearings (MM9300)
- Metric series bearings (MMBS)
- Flanged cylindrical cartridge housings (BSBU)
- Pillow block housings (BSPB)
- Integral double-row units (MMN, MMF)



## SELECTING THE APPROPRIATE MACHINE TOOL BEARING

### PRECISION TAPERED ROLLER BEARINGS

#### Angularity (K-factor)

The angled raceways allow the tapered roller bearing to carry combinations of radial and axial loads. Since load capacities are intrinsically linked to the bearing stiffness, the selection of the most appropriate tapered roller bearing cup angle can help optimize the bearing selection for a given application.

The angularity of the bearing is often described by a factor called "K." This factor is the ratio of basic dynamic radial load rating ( $C_{90}$ ) to basic dynamic axial load rating ( $C_{a90}$ ) in a single-row bearing. For a bearing with a ribbed cone (the most common design), it is a function of the half-included cup angle ( $\alpha$ ) and can be found listed with the geometry factors in the catalog appendix. The smaller the K factor, the steeper the bearing angle. (See Fig. 13).

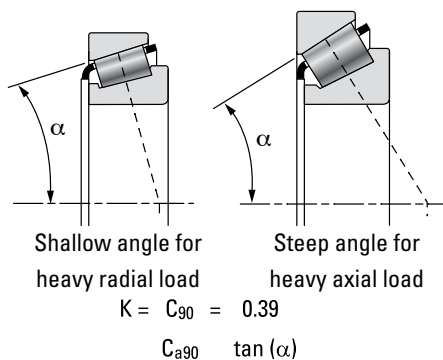

Fig. 13. Designs to support radial and axial loads in any combination.

#### Size

Optimizing stiffness is often a customer's primary design goal when choosing a tapered roller bearing. This usually results in the determination of a desired spindle diameter. Therefore, meeting a given envelope narrows the choices for the tapered roller bearing size selection.

#### Speed

The next most common criteria are the speed capability/limitations of the remaining potential candidates. This can be challenging, since the speed rating of a tapered roller bearing is a function of its internal geometry, the axial setting under operation conditions, the lubricant used and method of delivery. There is a speed guideline matrix on page 43 that will aid in determining the speed rating and suggested lubricant/delivery method for your tapered roller bearing application. Included in the appendix is a table listing the G1 and G2 factors that can be utilized to compare the relative speed capability and heat generation between the various tapered roller bearing selections. Please refer to the topics on permissible operating speeds and heat generation for further discussion.

#### Construction

Tapered bearings are uniquely designed to manage both axial and radial loads on rotating shafts and in housings. The steeper the cup angle, the greater the ability of the bearing to handle axial loads. Customized geometries and engineered surfaces can be applied to these bearings to further enhance performance in demanding applications.

Timken has designed a variety of tapered roller bearing types to specifically address various machine tool requirements. Each of these designs is best suited to a specific set of application needs. The key features of each type are highlighted below:

##### TS or TSF Bearing

- Most widely used type of tapered roller bearing
- Minimum precision grade Level 3 or C (ISO P5)
- TSF has a flanged outer ring to facilitate axial location
- Available in most bearing series
- Used in rotating shaft applications

##### TSMA Bearing

- Axial oil manifold with axial holes through rib
- Suitable with circulating oil or oil mist lubrication
- Centrifugal force distributes oil to critical rib/roller end contact
- Available in most precision grades
- Available in most bearing series
- Used in rotating shaft applications

**Hydra-Rib Bearing**

- Designed to maintain optimum spindle system preload
- Floating outer ring rib is positioned by a “pressure” system
- Rib in contact with the large roller ends instead of the usual fixed inner ring rib
- Variable preload setting adaptable to manual, tape, or computer control
- Wide speed range with optimum preload setting
- Improved spindle accuracy
- Improved static and dynamic stiffness
- Lower operating temperatures
- Heavier cuts with better tool life

**Spring-Rib Bearing**

- Designed to maintain optimum spindle system preload
- Floating outer ring rib is positioned by a “spring” system – pressurizing system not required
- Rib in contact with the large roller ends instead of the usual fixed inner ring rib
- Improved spindle accuracy
- Improved static and dynamic stiffness
- Heavier cuts with better tool life

**Crossed Roller Bearing**

- Designed to resist overturning loads
- Steep-angled geometry provides wider effective spread
- High tilting stiffness
- Adjustable design for optimum preload
- Compact design reduces space requirement
- Reduced application machining costs

**End Play (Preload)**

The end play of a tapered roller bearing during installation affects:

- Load zone control, impacting bearing life
- System rigidity, impacting deflection
- Housing and shaft diameter tolerances

End play/preload setting is determined based on desired stiffness, reduction in heat generation, and optimal rated life. For information on setting, please see page 93.

**Precision Class**

Typically, once the most appropriate bearing part number is identified for a particular application, the final parameter is the desired precision level. Standard class tapered roller bearings have crowned or enhanced profiles for races and rollers. Timken precision tapered roller bearings have straight profiles with running accuracy and performance meeting ISO P5, ISO P4, and ISO P2 levels. The Precision Plus series offers total radial runout of less than a single micron, exceeding the ISO P2 precision level and allowing for improved accuracy. The suggested assembly and/or inspection code (precision class and performance code) can be applied to the chosen part number to obtain the necessary precision level.

**Other**

Consult Timken for suggestions related to appropriate bearing enhancements that can improve the performance of your application.

Such enhancements might include unique precision levels, conversion of a TS-style design to a (flanged) TSF or (multi-row TDO, or possibly ceramic rolling elements for better stiffness and speedability.

### SUPER PRECISION BALL BEARINGS

As previously noted, optimizing speed, stiffness, accuracy and load capacity is often a customer's primary design goal. This usually results in the identification of several characteristics that will determine the final bearing selection. The following design variables influence bearing performance as noted.

#### Contact Angle

A contact angle is created between the rolling element and raceway to support a combination of radial and axial (thrust) loads. Deep-groove (Conrad) bearings designed with 0-degree contact angle are best for supporting radial loads or small axial loads in two directions. To support high axial or combination loads, angular contact bearings are often preferred. For additional support of radial and axial load in either direction, sets of bearings in opposing directions are utilized.

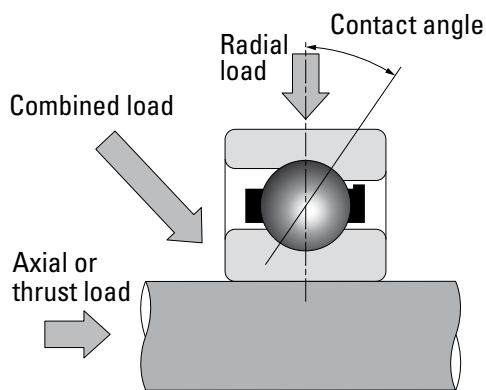

Fig 14. Example of ball bearing loading.

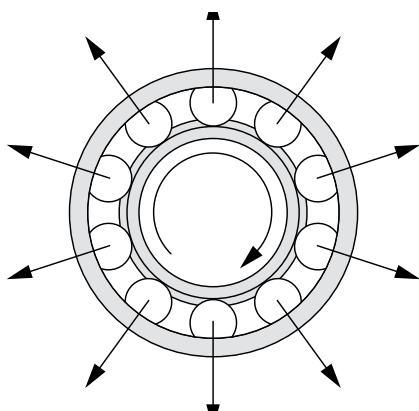

Fig 15. Centrifugal forces of a rotating ball bearing.

The majority of Timken angular contact super precision ball bearings are available with standard high (25 degree) and low (15 degree) contact angles, with additional options upon request. Each type has inherent characteristics that are desirable for machine tool spindles. Contact angle is chosen primarily based on the predominant load direction.

- 15° - used when loading is primarily radial; for very high speed applications
- 25° - used when loading is primarily axial
- 60° - highest axial stiffness; used in ball screw support bearings

High speeds cause centrifugal forces on the ball. A lower contact angle handles the centrifugal force more favorably as higher speeds lead to higher internal radial loads.

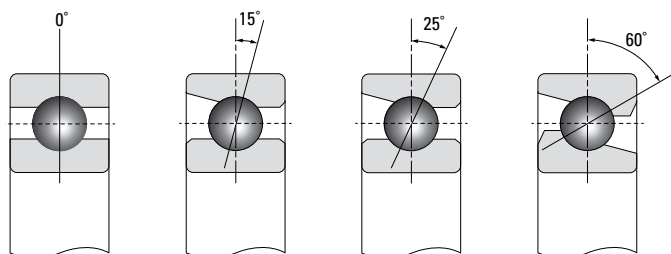

Fig 16. Examples of common machine tool ball bearing contact angles.

Spindle rotating speeds are limited by heat generated within the bearing assembly. As viewed in Fig. 17, a lower contact angle minimizes heat buildup yielding lower operating temperatures at higher speeds.

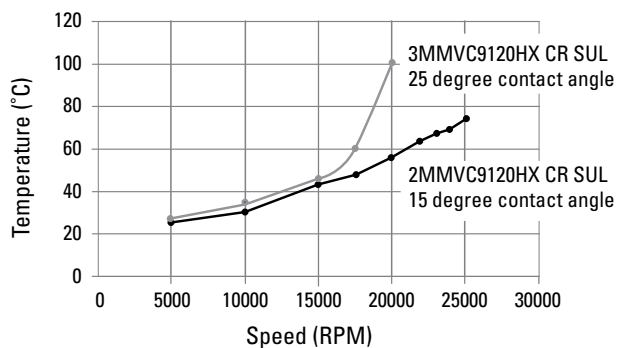

Fig 17. Effect of contact angle on temperature.

Axial deflection curves for two like-series, equal bore-sized bearings with standard preloads and contact angles are shown below.

A comparison of the curves in Fig. 18 shows the 25-degree contact angle bearing to be more rigid axially under axial loads than the 15-degree contact angle bearing. Similar comparisons of the radial deflection characteristics of the same two types of angular contact ball bearings can be made from the two graphs shown in Fig. 19. These curves show that decreased radial deflections result when bearings having a lower, 15-degree angle are used.

Generally, the force for the equivalent preload level for a 15-degree contact angle bearing is about one-half that of the preload level for a 25-degree contact angle bearing. Preload values for all Timken machine tool grade angular contact bearings are calculated to give optimum performance over a wide range of applications.

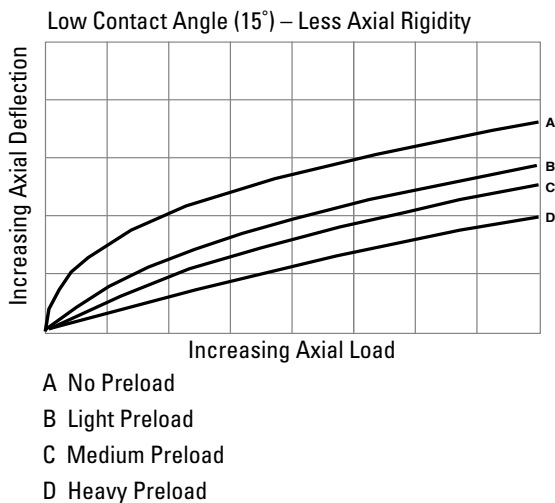
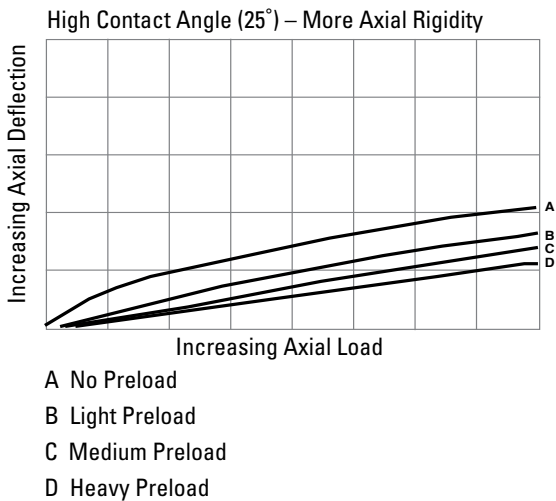
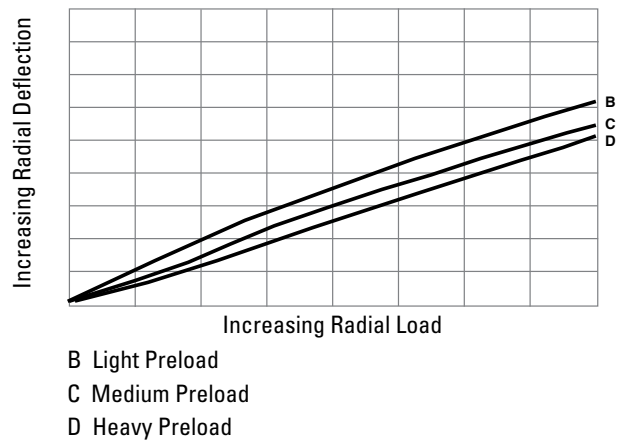

Fig. 18. Effect of contact angle on axial deflection.

High Contact Angle (25°) – Less Radial Rigidity



Low Contact Angle (15°) – More Radial Rigidity

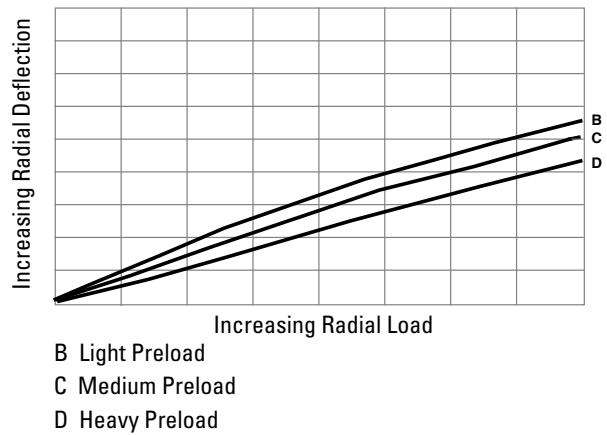

Fig. 19. Effect of contact angle on radial deflection.

Timken ball screw support bearings are designed with a 60-degree contact angle. They are used for low-speed operations and offer the highest axial stiffness in the standard super precision ball bearing machine tool line. As contact angle increases, axial stiffness increases, radial stiffness decreases, and maximum operating speed decreases.

## Spin To Roll Ratio

Though ball bearings are classified as rolling bearings, there is always some sliding action between the balls and the raceways in any bearing. No bearing can achieve 100 percent rolling action. This is because of relative rotation speeds between the points of primary contact on the inner and outer raceways. This is especially true in the case of angular contact ball bearings. An increase in spin is induced by excessive preloading, contact angle shift and increase in the operation speed. The measure of the roller spin is given by the spin to roll ratio. It describes the amount of spin a ball undergoes about an axis perpendicular to the bearing axis per unit rotation of the roller on the raceways. Higher the spin to roll ratio, higher is the heat generated in operation and lower is the life expectancy of the bearing.

## Contact Angle Shift

Bearings are generally assembled onto a shaft or into a housing using interference fits to avoid creep (slippage). This causes a reduction in the bearing internal clearance. Additionally, angular contact ball bearings are preloaded in order to eliminate any remaining internal clearances and achieve the desired axial and radial rigidity. Preloading of a bearing causes deflections in the internal geometry and results in a shift in the contact points between the rollers and the raceways. This in turn causes a shift in the contact angle. While preloading is recommended to achieve the optimum life and performance of the bearing, the selection of the catalog preload must be done carefully, taking into consideration the fits, operation temperature and the operational preload to minimize the contact angle shift.

## Precision Class

Super high precision MM/MMV (P4S) bearings are manufactured with running accuracy and performance meeting ABEC 9/ISO P2 while maintaining other features at ABEC 7/ISO P4 levels for cost-effectiveness.

Ultraprecision MMX (P2) ABEC 9/ISO P2 have closer tolerances on bore and O.D. Bearings produced to these tolerances are used on ultra-high-speed grinding spindles designed for tight dimensional tolerances and superfine surface finishes.

## Hybrid Ceramic

Timken has designed an advanced bearing that combines ceramic rolling elements with premium steel rings and state-of-the-art bearing technology to achieve maximum speed capability and greater stiffness. Compared with an all-steel bearing, the hybrid

ceramic bearing's lower friction characteristics, even under marginal lubrication, result in less ball skidding, lower heat generation, higher speeds and greater overall system reliability.

Ceramic balls are 60 percent lighter than steel with extremely fine surface finishes equal to or less than 0.5 microinch Ra. This helps to reduce centrifugal forces and allows for a 20 percent higher speed factor than steel balls. Oil-lubricated ceramic hybrid bearings can operate up to three million dN, while grease-lubricated ceramic hybrids can run up to one million dN.

$$dN = \text{bore size (mm)} \times \text{speed (RPM)}$$

The ceramic material has a modulus of elasticity 50 percent greater than steel, increasing bearing rigidity. This higher stiffness may result in higher contact stress levels in the bearings. Ceramics are generally not appropriate for higher loads and/or low speeds. As seen in Fig. 20, below 750,000 dN, ceramic balls experience a reduction in overall rated bearing life.

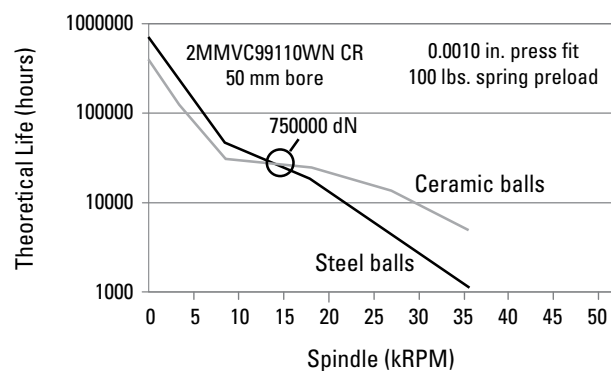

Fig. 20. L<sub>10</sub> life vs. speed comparison of steel and ceramic balls.



### Size/Series

Increasing bearing size causes an increase in centrifugal forces which, as discussed earlier, reduces the speedability of the bearing. An increase in ISO cross-section series improves the ability of a bearing to carry higher loads as shown in Fig. 21.

- 9300 (71900) series: ultra-light loads, high speed
- 9100 (7000) series: extra-light loads, high speed
- 200 (7200) series: light loads
- 300 (7300) series: medium loads

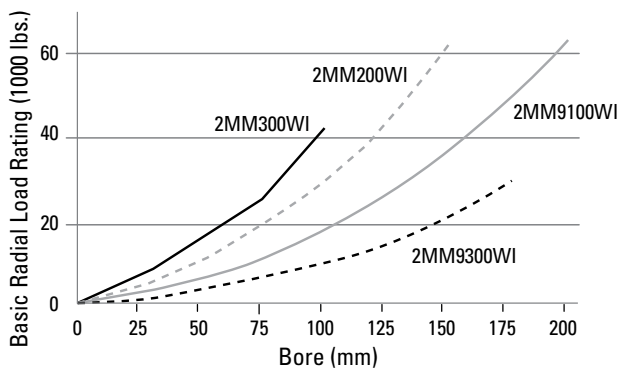
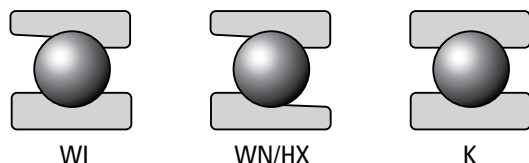

**Fig. 21. Angular contact ball bearing load ratings.**

When stiffness is a factor of the design, this usually results in the determination of a desired spindle diameter and corresponding bearing bore size. Speedability and load capacity then determine the series selected.

### Construction

WI is the standard construction for an angular contact ball bearing. The WI-type has full shoulders on both sides of the inner ring and a low shoulder on the outer ring. This simplifies bearing assembly during manufacturing.



**Fig. 22. Angular contact spindle bearing types.**

Timken has developed an HX bearing design to enhance two key factors contributing to metalworking throughput: spindle speed and radial stiffness. This design enables spindle heads to remove more material in less time while maintaining superior finished product tolerances by minimizing tool “wander.” This efficient combination translates into faster turnaround of finished product. These improvements are imparted by subtle changes to ball complements and internal geometries. The Timken HX Series is dimensionally interchangeable with the 9300 and 9100 (71900 and 7000) series ball bearings.

The HX and WN-types also are designed to meet the needs of machine manufacturers who require optimum lubrication through the bearings. These designs incorporate a low shoulder on the non-thrust side of both the inner and outer rings to facilitate oil flow.

K-type, deep groove (Conrad), 0-degree radial ball bearings are generally chosen in applications where capacity and stiffness do not require a duplex set of bearings. Axial load applied to the bearing will increase the contact angle.

### Cage (Retainer or Separator)

A cage’s function is to separate the rolling elements within the bearing. It first affects bearing performance by adding weight, which will increase the centrifugal forces and resulting radial load at high speeds. This limits the ability of the bearing to perform at high temperatures. Timken’s range of cage types includes:

- CR/T** Phenolic (composition) - standard
- PRL** Molded polymer cage - new
- PRC** Molded reinforced nylon - former standard
- MBR** Machined bronze
- PRJ** High-performance polymer
- SR** Silver-plated machined steel

Timken’s phenolic composition cage is standard for high-speed applications up to 93° C (200° F). For high-heat applications, machined bronze is often used. However, the increase in weight reduces the speedability of the bearing assembly.

### Seals

Seals are used to exclude contaminants and retain lubricant for reliable bearing operation and extended service life. The HX bearing has an optional non-contacting seal, available as single or pair (V, VV). The WI 9100/7000 and 9300/71900 series have an optional light-drag contacting seal (P, PP). Ball screw support bearing cartridges (MMN/MMF) include integral, low-torque contact seals.

### Bearing Set Quantity

Timken super precision ball bearings are available as single, duplex, triplex, and quadruplex matched sets:

- SU (X, L, M, H) - single bearing/preload level
- DU (X, L, M, H) - duplex pairs/preload level
- TU (X, L, M, H) - triplex set/preload level
- QU (X, L, M, H) - quadruplex set/preload level

Each additional bearing increases system rigidity and load-carrying capabilities. The quantity of bearings in a set is specified in the part number as shown.

Timken super precision ball bearings are universal flush ground, which allows for DB (back-to-back), DF (face-to-face), or DT (tandem) mounting of all matched duplex sets. This does not need to be specified during order.

### Preload Level

The internal condition of a preloaded ball bearing is similar to that of one in operation under axial load. This initial axial load serves to decrease markedly the axial and radial deflections when subsequent operational loads are imposed on the bearing assembly. Preload levels limit change in contact angle at very high speeds, and prevent ball skidding under very high acceleration and speed.

In many cases, the amount of bearing preload is a trade-off between having the desired degree of rigidity and reducing any adverse effect preloading has on the equipment. If the operating speed is high, a heavy preload can lead to excessively high operating temperatures, which may result in bearing damage. To match general performance requirements, four classes of ball bearing preloads are used – extra-light, light, medium and heavy. To maximize performance, Timken can design specially preloaded super precision ball bearings.

Bearings come from the factory with a dimensional preload ground into the bearing ring faces. The preload changes as the raceway diameters change. Once the operational preload is determined, it is important that the correct factory (catalog) preload is selected because when the bearings are mounted on the shaft with an interference fit, the dimensional setting (or preload) increases. When the bearings are in operation and there is a temperature difference between the inner and outer rings, the dimensional setting (or preload) again increases.

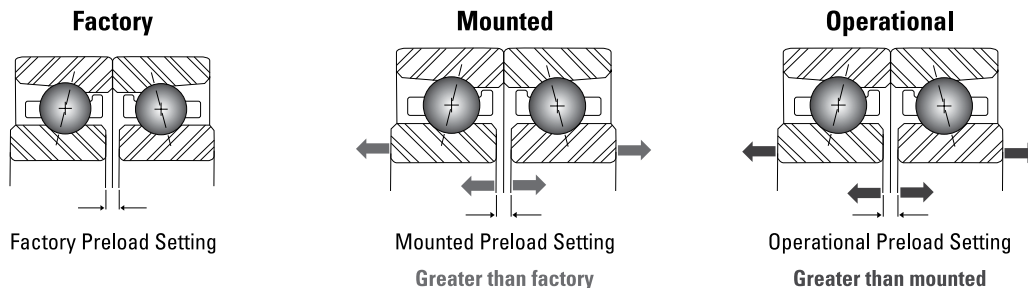

Fig. 23. Preload settings.

### Sealed Ball Screw Support Bearings

Available in flanged (MMF) and non-flanged (MMN) series, these designs simplify installation for both standard and rotating nut mountings. The flanged version eliminates the need for external clamping of the outer ring. The standard version is the sealed duplex configuration, but both series may be ordered with seals or shields in either a duplex or quad set arrangement.

### Wear/Debris-Resistant Material

Advanced bearings can resist debris wear for improved machine tool performance and service life. Timken super precision bearings with WearEver technology combine a special high-alloy steel with ceramic balls to provide superior performance and cutting quality for high-speed applications. Extended capabilities help improve machine efficiency and utilization while reducing secondary finishing operations and downtime.

This unique, wear/debris-resistant steel was specifically incorporated into the bearing design to withstand damage from hard contaminants, a primary cause for shortened bearing life. Studies have shown that bearings with this advanced material can deliver up to ten times the standard service life in the presence of hard contamination. This represents a significant advancement in high-speed machining productivity and improved product quality. Consult your Timken representative for availability.

### Other

Bearings may be customized to specify lubrication type, special coding, special part marking, etc. Contact your Timken representative for more information.

2 MM C 91 04 WI CR DUL A4437  
 (C 70 04 C - T - P4S - DUL) FS637

**A4437** = Special coding requirement  
**FS637** = Kluber isoflex NBU 15 Grease

Fig. 24. Examples of non-standard specification numbers.

## SPINDLE SYSTEM CHARACTERISTICS

A machine tool designer’s goal is to build a precise spindle with the least possible vibration and with the optimum heat generation and dissipation characteristics. This will then produce the best surface finish, dimensional accuracy and optimum production rates.

Due to increasing cutting speeds and forces, machine tool builders are developing spindle designs to improve dynamic stiffness.

Dynamic stiffness depends upon:

- Static stiffness
- Damping
- Mass

From a design standpoint, the bearing selection has little effect on mass, but static stiffness and damping can be altered by bearing and application design criteria. The natural frequency of a system can be radically altered by any change in the static stiffness. On the other hand, damping will determine the magnitude of displacement of a system in the chatter mode. Tests have shown that the damping varies with the type of rolling bearing used.

## SPINDLE SYSTEM STATIC STIFFNESS

The static stiffness, or “spring rate,” of a system is defined as the ratio of the amount of load to the deflection of the spindle at the point of load, and is expressed in N/mm (lbs./in.).

In conventional spindle designs, the load is usually applied at the end of the spindle nose.

In a spindle system, a few factors contribute to the total static stiffness:

- Bare spindle stiffness
- Bearing stiffness
- Housing stiffness

## Bare Spindle Stiffness

Fig. 25 illustrates the important elements that need to be considered to determine the bare spindle stiffness:

- Diameter of the spindle
- Overhung distance from the nose bearing to the load
- Bearing spread

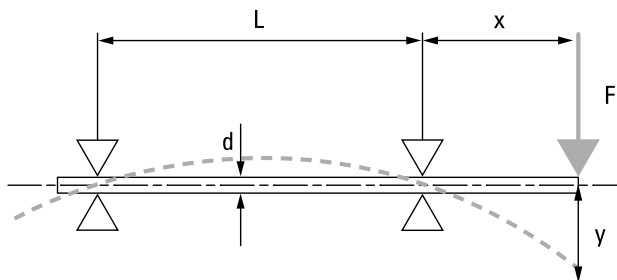

Fig. 25. Deflection of the bare spindle on two supports.

The maximum value of the spindle deflection at the point of load is:

$$y = \frac{F_r x^2 (x + L)}{3EI} \text{ (mm)} \quad \text{with } I = \frac{\pi \times d^4}{64} \text{ (mm}^4\text{)}$$

Where:

$F_r$	= radial load applied at spindle nose	(N)
$L$	= bearing spread	(mm)
$x$	= overhung distance	(mm)
$I$	= moment of inertia	(mm <sup>4</sup> )
$y$	= deflection at point of load	(mm)
$d$	= diameter of spindle	(mm)
$E$	= modulus of elasticity	(N/mm <sup>2</sup> )

Therefore, the static stiffness of the bare spindle at this point is

$$K = \frac{F_r}{y} = \frac{3EI}{x^2(x + L)} = \frac{3E\pi d^4}{64x^2(x + L)}$$

The previous formula shows that the diameter of a shaft is considered to the fourth power. Thus, any increase in spindle diameter will significantly increase stiffness. From a design standpoint, this means that the selected bearings should have as large a bore diameter as practical for a given outside diameter (Fig. 26 on the following page).

The overhung distance from the nose bearing to the applied loads is generally fixed by design constraints (or load cycles). However, the stiffness of the bare spindle can be increased by determining the optimum spread between the two supports. For a given overhung distance “x,” the bearing spread has an optimum value for minimum deflection at the cutting point (Fig. 27).

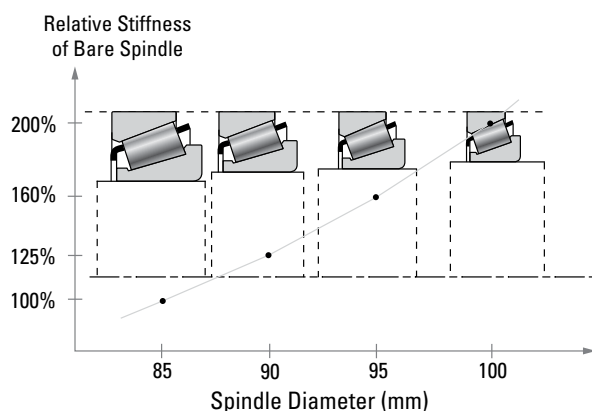

**Fig. 26. Influence of spindle diameter on its stiffness for different tapered roller bearing sections within same envelope (85 mm bore taken as reference).**

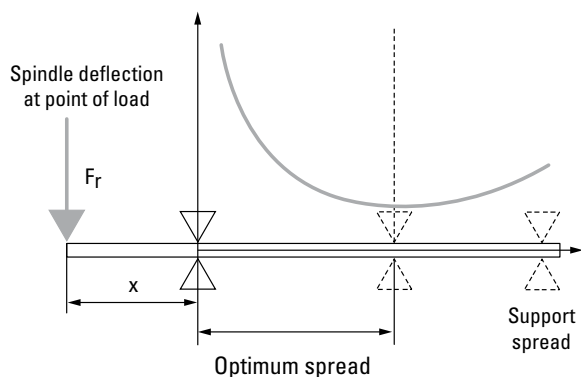
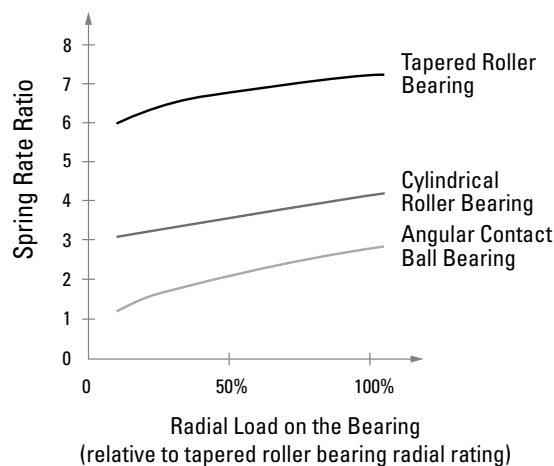

**Fig. 27. Influence of spread on bare spindle deflection at point of load.**

### Bearing Stiffness

Stiffness is significant in precision machining applications. This impacts machine repeatability and running accuracy. Bearing stiffness is determined by movement or microscopic deflection under load within the bearing assembly.

Because of the contribution of bearing stiffness to the global system, it is of prime importance to consider the effect of the selection of the bearing and its geometrical characteristics. A tapered roller bearing is a line contact bearing with a high number of rolling elements. Compared to other popular bearings in spindle applications, such as angular contact ball bearings (point contact) or cylindrical roller bearings (line contact), the preloaded tapered roller bearing (line contact) has a significantly higher radial stiffness in the same given envelope.



**Fig. 28. Radial spring rate comparison between popular machine tool bearings of a comparable size under zero internal clearance.**

Comparisons (Fig. 28) show that a tapered roller bearing has as much as six times more radial stiffness than a comparable size angular contact ball bearing, and twice as much as a comparable size cylindrical roller bearing, for a zero clearance condition. Therefore, for most spindle applications only two tapered roller bearings are required, which can result in a more economical solution.

### Housing Stiffness

Experience and basic calculations show that good axial and radial housing stiffness are required to support the loads that are transmitted through the bearings. In most machine tool designs, the housing is normally adequate. However, when light sections or nonferrous housings are used, the axial and radial housing stiffness should be verified.

**SPINDLE SYSTEM DYNAMIC STIFFNESS**

Dynamic stiffness is influenced to a large degree by the damping characteristics and the static stiffness of the system.

Fig. 29 demonstrates that bearing setting plays a major role in the static stiffness of a spindle-bearing-housing system. As the preload is increased, the static stiffness increases.

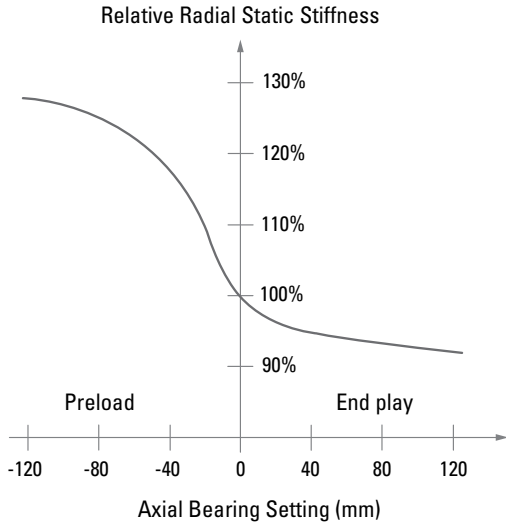

**Fig. 29. Effect of bearing setting on spindle system static stiffness.**

A load that would cause very little static deflection can cause very high dynamic deflections if the frequency of the dynamic load is the same as the natural frequency of the spindle. To control the dynamic stiffness, the damping characteristics of the system are very important.

Damping can be visualized as resistance to vibration. It can be seen in Fig. 30 that the damping ratio of a spindle system is higher when bearings are preloaded. The optimum value is, however, obtained around the zero clearance condition.

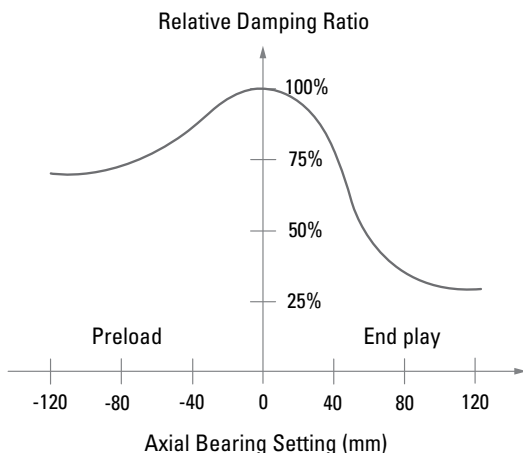

**Fig. 30. Effect of bearing setting on spindle system damping ratio.**

Finally, the resulting dynamic stiffness characteristics of a spindle system are directly affected by the bearing setting. The curve plotted in Fig. 31 shows an optimum setting slightly in the preload region. This gives the least compliance, or maximum dynamic stiffness, of a spindle system since the damping decreases as preload increases. As previously explained, any preload increase beyond the optimum setting will reduce the dynamic spindle characteristics.

Extensive research by Timken has resulted in a better knowledge of machine tool spindle behavior. It was identified that higher accuracy and improved surface finish can be achieved at an optimum preload setting (Fig. 32).

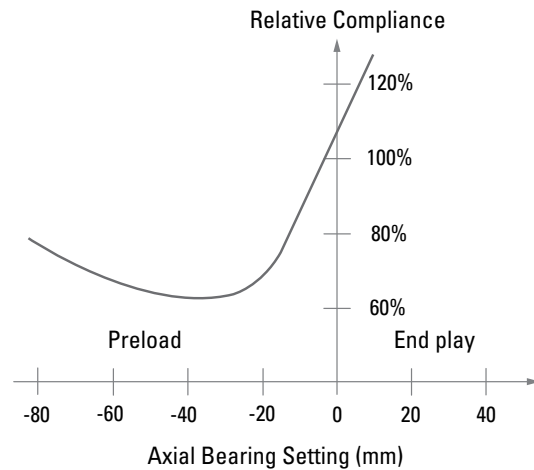

**Fig. 31. Effect of bearing setting on spindle system dynamic stiffness.**

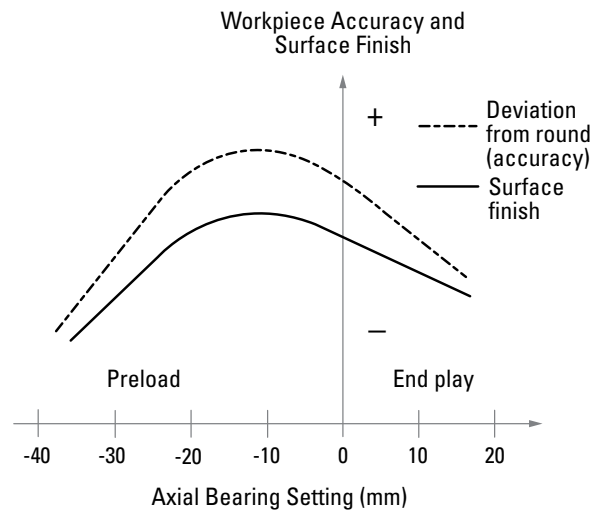
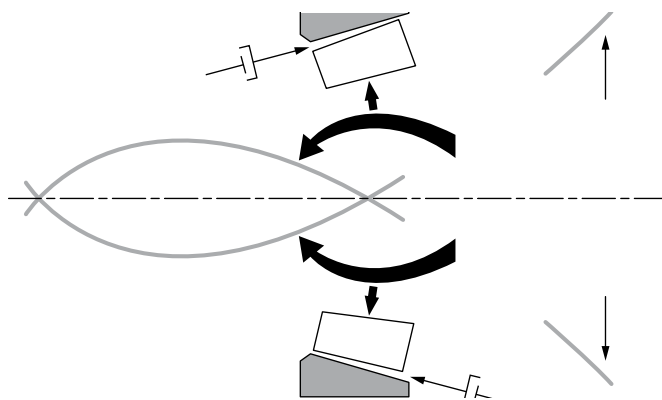

**Fig. 32. Effect of bearing setting on surface finish and accuracy of the workpieces.**



The unique design of a tapered roller bearing with its line contact produces a damping characteristic that is not necessarily inherent to other bearing designs (Fig. 33). This is due to the bending mode of the spindle and bearing centerline caused by dynamic deflection which is resisted inside the bearing through a shearing action of the viscous lubricant between the rollers and the cup and cone races.

It is the combination of the tapered roller bearing construction and proper bearing setting that results in improved damping characteristics.



**Fig. 33. Damping in a tapered roller bearing.**

An extension of this insight culminated in the development of a bearing system called the Hydra-Rib. It is, specifically designed to provide the optimum bearing preload and thus the ultimate dynamic stability for the spindle system under any operating conditions.

Proper selection of the preload for a given application must not focus only on stiffness and damping characteristics. Also, the lubrication method, operating speeds and loads must be reviewed to determine the optimum setting/preload to maximize performance. Consult the appropriate topic in this engineering section for more details.

## OTHER FACTORS AFFECTING BEARING SELECTION

Some additional controllable factors having a significant impact on bearing performance include mounting fits, internal clearances, lubricant type and integrity. For example, when using radial ball bearings, appropriate internal clearance is needed to ensure proper operation.

### THERMAL EXPANSION

Issues such as axial displacement must be addressed where shaft length differentials must be tolerated when thermal expansion occurs. For these situations, the rotating component supports include a fixed (locating) and floating (non-locating) bearing arrangement.

The fixed bearing is subject to combination loads and is usually placed nearest the working end of the shaft to minimize motion and thereby maintain workpiece accuracy. Installation considerations for the typical fixed bearing positions should note the fitting suggestions listed in this catalog. These are compiled from a wealth of experience in a wide range of operating conditions.

Where floating bearings are necessary, the design must allow for axial displacement of the shaft. This can be accomplished by allowing the bearing to “slide” laterally along the shaft or housing respectively. A looser fit during the machining of the shaft or housing cavity is required. This not only alleviates the axial stresses on this end of the assembly, but will also facilitate bearing and shaft installation.

### MISALIGNMENT

When the size of the machine increases, so do concerns about alignment. Shaft bending or additional loading can impart moment loads that need to be considered. Bearing selection must further consider installation practices with distant machined bearing housing cavities. Manufacturing limitations to position housing bores might encourage the choice of a self-aligning bearing mounting (DF, face-to-face).

This can help compensate for machining variations and assist in managing dynamic forces by featuring a spherical outside diameter or thrust face.

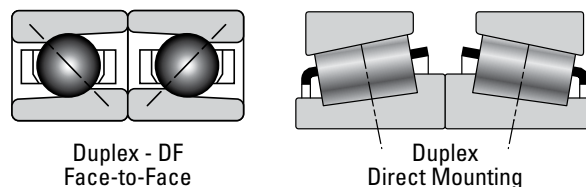

**Fig. 34. Self-aligning bearing mountings.**

**EFFECTIVE SPREAD**

When a load is applied to a tapered roller or angular contact ball bearing, the internal forces at each rolling element-to-outer raceway contact act normal to the raceway. These forces have radial and axial components. With the exception of the special case of pure axial loads, the inner ring and the shaft will experience moments imposed by the asymmetrical axial components of the forces on the rolling elements.

It can be demonstrated mathematically that, if the shaft is modeled as being supported at its effective bearing center rather than at its geometric bearing center, the bearing moment may be ignored when calculating radial loads on the bearing. Only externally applied loads

need to be considered, and moments are taken about the effective centers of the bearings to determine loads or reactions. Fig. 35 shows single-row bearings in a direct and indirect mounting configuration. The choice of whether to use direct or indirect mounting depends upon the application.

With so many factors to consider for the successful operation of any device incorporating rolling bearings, Timken brings to its customers more than a century of talent and experience to assist with these choices. Though the content in this catalog is an excellent start in the rolling bearing selection process, it should not be considered the final word. Timken bearing expertise is only a phone call away.

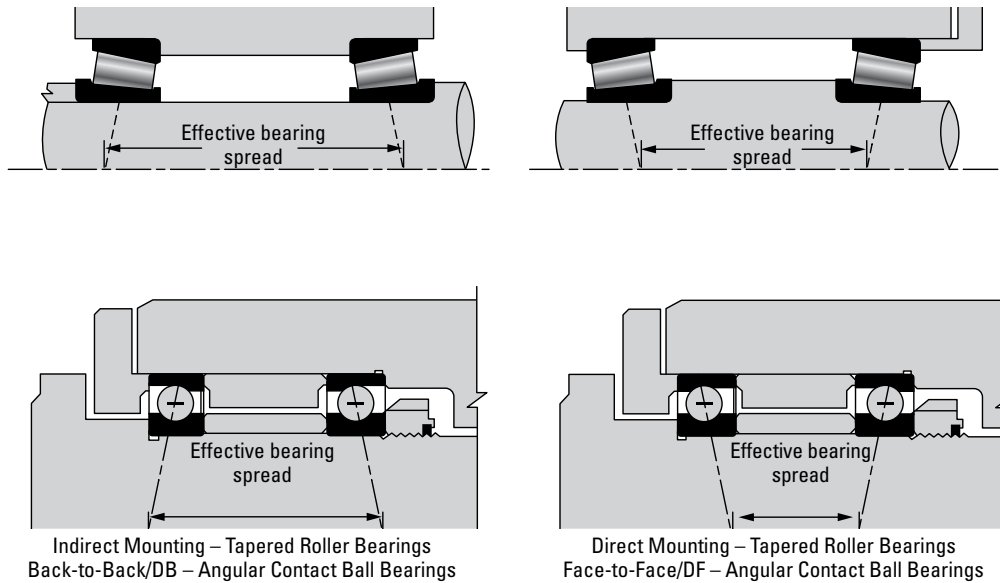

**Fig. 35. Choice of mounting configuration for single-row bearings, showing position of effective load-carrying centers.**

# APPLIED LOADS AND BEARING ANALYSIS

This key is not intended to be comprehensive, but serves as a useful reference for symbols found in this catalog.

## SUMMARY OF SYMBOLS USED IN THIS CATALOG

Symbol	Description	Units	Symbol	Description	Units
A <sub>1</sub>	Reliability Life Factor		K	Tapered Roller Bearing Radial-to-Axial Dynamic Load Rating Factor	
a <sub>2</sub>	Material Life Factor		K <sub>T</sub>	Relative Axial Load Factor (Ball Bearings)	
a <sub>3</sub>	Operating Condition Life Factor		L <sub>H</sub>	Lead Axial Advance of a Helix for One Complete Revolution	mm, in.
a <sub>3d</sub>	Debris Life Factor		L	Distance Between Bearing Geometric Center Lines	mm, in.
a <sub>3h</sub>	Hardness Life Factor		m	Gearing Ratio	
a <sub>3k</sub>	Load Zone Life Factor		M	Bearing Operating Torque or Moment	N-m, N-mm, lbf-in.
a <sub>3l</sub>	Lubrication Life Factor		n	Bearing Operating Speed or General Term for Speed	rot/min, RPM
a <sub>3m</sub>	Misalignment Life Factor		n <sub>G</sub>	Gear Operating Speed (RPM)	rot/min, RPM
a <sub>3p</sub>	Low Load Life Factor		n <sub>P</sub>	Pinion Operating Speed (RPM)	rot/min, RPM
a <sub>e</sub>	Effective Bearing Spread	mm, in.	n <sub>W</sub>	Worm Operating Speed (RPM)	rot/min, RPM
b	Tooth Length	mm, in.	N <sub>G</sub>	Number of Teeth in the Gear	
c <sub>1, c2</sub>	Linear Distance (positive or negative)	mm, in.	N <sub>P</sub>	Number of Teeth in the Pinion	
C	Dynamic Radial Load Rating	N, lbf	N <sub>S</sub>	Number of Teeth in the Sprocket	
C <sub>0</sub>	Static Load Rating	N, lbf	P <sub>a</sub>	Dynamic Equivalent Axial Load	N, lbf
C <sub>90</sub>	Single-Row Basic Dynamic Load Rating	N, lbf	P <sub>0</sub>	Static Equivalent Load	N, lbf
C <sub>e</sub>	Extended Dynamic Capacity	N, lbf	P <sub>0a</sub>	Static Equivalent Axial Load	N, lbf
C <sub>p</sub>	Specific Heat of Lubricant	J/(kg · °C), BTU/(lb x °F)	P <sub>0r</sub>	Static Equivalent Radial Load	N, lbf
d	Bearing Bore Diameter	mm, in.	P <sub>r</sub>	Dynamic Equivalent Radial Load	N, lbf
d <sub>c</sub>	Distance Between Gear Centers	mm, in.	Q	Generated Heat or Heat Dissipation Rate	W, BTU/min
d <sub>m</sub>	Mean Bearing Diameter	mm, in.	r	Radius	
dN	Bore in mm • RPM		R	Percent Reliability Used in the Calculation of the a <sub>1</sub> Factor	
D	Bearing Outside Diameter	mm, in.	T	Torque	N-m, lbf-in.
D <sub>m</sub>	Mean Diameter or Effective Working Diameter of a Sprocket, Pulley, Wheel or Tire Also, Tapered Roller Bearing Mean Large Rib Diameter	mm, in.	v	Vertical (used as subscript)	
D <sub>mG</sub>	Mean or Effective Working Diameter of the Gear	mm, in.	V	Linear Velocity or Speed	km/h, mph
D <sub>mP</sub>	Effective Working Diameter of the Pinion	mm, in.	V <sub>r</sub>	Rubbing, Surface or Tapered Roller Bearing Rib Velocity	m/s, fpm
D <sub>mW</sub>	Effective Working Diameter of the Worm	mm, in.	α X	Dynamic Radial Load Factor	
D <sub>pG</sub>	Pitch Diameter of the Gear	mm, in.	Y	Dynamic Axial Load Factor	
D <sub>pP</sub>	Pitch Diameter of the Pinion	mm, in.	Y <sub>1, Y2, Y3</sub>	Axial Load Factors	
D <sub>pW</sub>	Pitch Diameter of the Worm	mm, in.	Y <sub>G</sub>	Bevel Gearing – Gear Pitch Angle	deg.
e	Life Exponent			Hypoid Gearing – Gear Root Angle	deg.
f	Lubricant Flow Rate	L/min, U.S. pt/min	Y <sub>P</sub>	Bevel Gearing – Pinion Pitch Angle	deg.
f <sub>B</sub>	Belt or Chain Pull Factor			Hypoid Gearing – Pinion Face Angle	deg.
F	General Term for Force	N, lbf		Half Included Cup Angle	deg.
F <sub>a</sub>	Applied Axial Load	N, lbf	A, B...	Bearing Position (used as a subscript)	cSt
F <sub>ae</sub>	External Axial Load	N, lbf	η	Efficiency, Decimal Fraction	
F <sub>aG</sub>	Axial Force on Gear	N, lbf	θ <sub>ambt</sub>	Ambient Temperature	°C, °F
F <sub>aP</sub>	Axial Force on Pinion	N, lbf	θ <sub>1, θ2, θ3</sub>	Gear Mesh Angles Relative to the Reference Plane	deg.
F <sub>aW</sub>	Axial Force on Worm	N, lbf	θ <sub>i, θo</sub>	Oil Inlet or Outlet Temperature	°C, °F
F <sub>c</sub>	Centrifugal Force	N, lbf	λ	Worm Gear Lead Angle	deg.
F <sub>r</sub>	Applied Radial Load	N, lbf	μ	Coefficient of Friction	
F <sub>sG</sub>	Separating Force on Gear	N, lbf	v	Lubricant Kinematic Viscosity	cSt
F <sub>sP</sub>	Separating Force on Pinion	N, lbf	σ <sub>0</sub>	Approximate Maximum Contact Stress	MPa, psi
F <sub>sW</sub>	Separating Force on Worm	N, lbf	Φ	Normal Tooth Pressure for the Worm (Gearing)	deg.
F <sub>tG</sub>	Tangential Force on Gear	N, lbf	Φ <sub>G</sub>	Normal Tooth Pressure Angle for the Gear	deg.
F <sub>tP</sub>	Tangential Force on Pinion	N, lbf	Φ <sub>P</sub>	Normal Tooth Pressure Angle for the Pinion	deg.
F <sub>tW</sub>	Tangential Force on Worm	N, lbf	ψ <sub>G</sub>	Helix (Helical) or Spiral Angle for the Gear	deg.
F <sub>W</sub>	Force of Unbalance	N, lbf	ψ <sub>P</sub>	Helix (Helical) or Spiral Angle for the Pinion	deg.
F <sub>ΦP</sub>	Axial Force on Pinion	N, lbf	ρ	Lubricant Density	kg/m <sup>3</sup> , lb/ft <sup>3</sup>
H	Power	kW, HP	1, 2, ...n	Conditions (used as subscript)	
HF <sub>s</sub>	Static Load Rating Adjustment Factor for Raceway Hardness				
k	Centrifugal Force Constant	lbf/RPM <sup>2</sup>			
k <sub>1</sub>	Bearing Torque Constant	N-m, lbf-in.			
k <sub>4, k5, k6</sub>	Dimensional Factor to Calculate Heat Generation				

The following equations are used to determine the forces developed by machine elements commonly encountered in bearing applications.

**SPUR GEARING**  
**TANGENTIAL FORCE**

$$F_{tG} = \frac{(1.91 \times 10^7) H}{D_{pG} n_G} \quad (\text{newtons})$$

$$= \frac{(1.26 \times 10^5) H}{D_{pG} n_G} \quad (\text{pounds-force})$$

**SEPARATING FORCE**

$$F_{sG} = F_{tG} \tan \phi_G$$

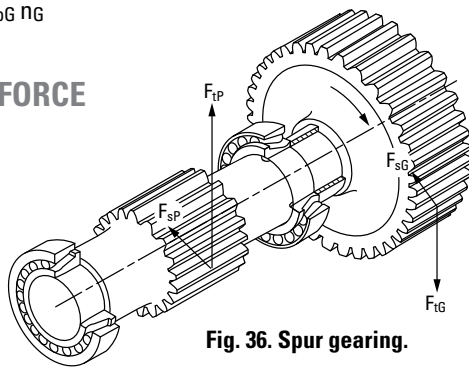

Fig. 36. Spur gearing.

**SINGLE HELICAL GEARING**  
**TANGENTIAL FORCE**

$$F_{tG} = \frac{(1.91 \times 10^7) H}{D_{pG} n_G} \quad (\text{newtons})$$

$$= \frac{(1.26 \times 10^5) H}{D_{pG} n_G} \quad (\text{pounds-force})$$

**THRUST FORCE**

$$F_{aG} = F_{tG} \tan \psi_G$$

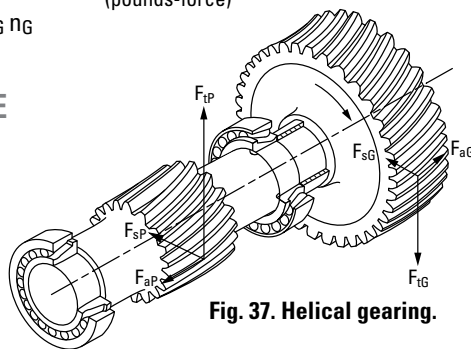

Fig. 37. Helical gearing.

**SEPARATING FORCE**

$$F_{sG} = \frac{F_{tG} \tan \phi_G}{\cos \psi_G}$$

**STRAIGHT BEVEL AND ZEROL GEARING WITH ZERO DEGREES SPIRAL**

In straight bevel and zerol gearing, the gear forces tend to push the pinion and gear out of mesh, such that the direction of the thrust and separating forces is always the same regardless of direction of rotation (Fig. 38). In calculating the tangential force (\$F\_{tP}\$ or \$F\_{tG}\$) for bevel gearing, the pinion or gear mean diameter (\$D\_{mP}\$ or \$D\_{mG}\$) is used instead of the pitch diameter (\$D\_{pP}\$ or \$D\_{pG}\$). The mean diameter is calculated as follows:

$$D_{mG} = D_{pG} - b \sin \gamma_G \quad \text{or} \quad D_{mP} = D_{pP} - b \sin \gamma_P$$

In straight bevel and zerol gearing:

$$F_{tP} = F_{tG}$$

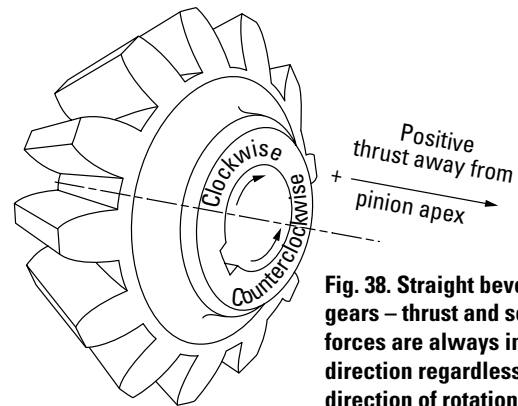

Fig. 38. Straight bevel and zerol gears – thrust and separating forces are always in same direction regardless of direction of rotation.

**PINION**  
**TANGENTIAL FORCE**

$$F_{tP} = \frac{(1.91 \times 10^7) H}{D_{mP} n_P} \quad (\text{newtons})$$

$$= \frac{(1.26 \times 10^5) H}{D_{mP} n_P} \quad (\text{pounds-force})$$

**THRUST FORCE**

$$F_{aP} = F_{tP} \tan \phi_P \sin \gamma_P$$

**SEPARATING FORCE**

$$F_{sP} = F_{tP} \tan \phi_P \cos \gamma_P$$

**STRAIGHT BEVEL GEAR  
TANGENTIAL FORCE**

$$F_{tG} = \frac{(1.91 \times 10^7) H}{D_{mG} n_G} \quad (\text{newtons})$$

$$= \frac{(1.26 \times 10^5) H}{D_{mG} n_G} \quad (\text{pounds-force})$$

**THRUST FORCE**

$$F_{aG} = F_{tG} \tan \phi_G \sin \gamma_G$$

**SEPARATING FORCE**

$$F_{sG} = F_{tG} \tan \phi_G \cos \gamma_G$$

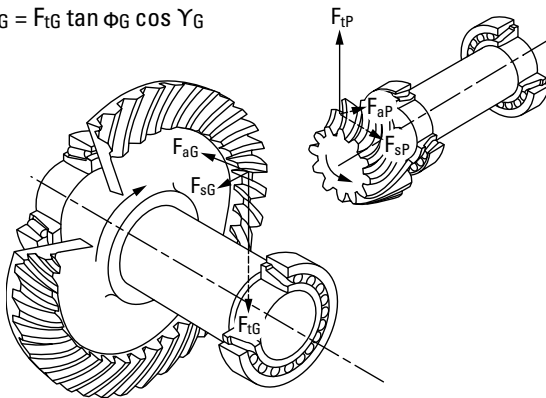

Fig. 39. Straight bevel gearing.

**SPIRAL BEVEL AND HYPOID GEARING**

In spiral bevel and hypoid gearing, the direction of the thrust and separating forces depends upon spiral angle, hand of spiral, direction of rotation, and whether the gear is driving or driven (see table 4). The hand of the spiral is determined by noting whether the tooth curvature on the near face of the gear (Fig. 40) inclines to the left or right from the shaft axis. Direction of rotation is determined by viewing toward the gear or pinion apex.

In spiral bevel gearing:

$$F_{tP} = F_{tG}$$

In hypoid gearing:

$$F_{tP} = \frac{F_{tG} \cos \psi_P}{\cos \psi_G}$$

Hypoid pinion effective working diameter:

$$D_{mP} = D_{mG} \left( \frac{N_p}{N_G} \right) \left( \frac{\cos \psi_G}{\cos \psi_P} \right)$$

**TANGENTIAL FORCE**

$$F_{tG} = \frac{(1.91 \times 10^7) H}{D_{mG} n_G} \quad (\text{newtons})$$

$$= \frac{(1.26 \times 10^5) H}{D_{mG} n_G} \quad (\text{pounds-force})$$

Hypoid gear effective working diameter:

$$D_{mG} = D_{pG} - b \sin \gamma_G$$

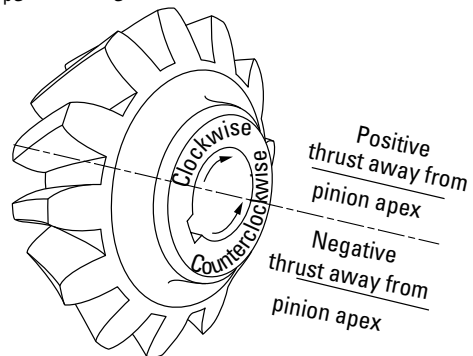

Fig. 40 Spiral bevel and hypoid gears – the direction of thrust and separating forces depends upon spiral angle, hand of spiral, direction of rotation, and whether the gear is driving or driven.

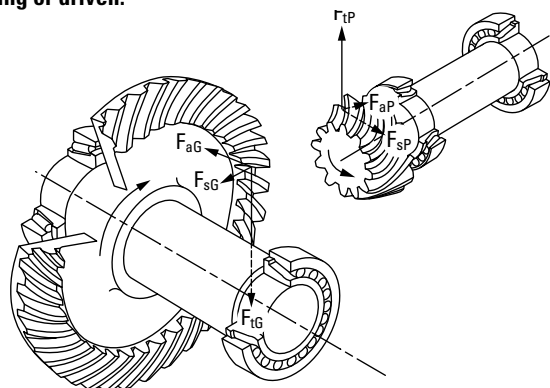

Fig. 41. Spiral bevel and hypoid gearing.

**TABLE 3.**  
**SPIRAL BEVEL AND HYPOID BEARING EQUATIONS**

Driving Member Rotation	Thrust Force	Separating Force
Right hand spiral clockwise or Left hand spiral counterclockwise	Driving member $F_{aP} = \frac{F_{tP}}{\cos \psi_P} (\tan \phi_P \sin \gamma_P - \sin \psi_P \cos \gamma_P)$	Driving member $F_{sP} = \frac{F_{tP}}{\cos \psi_P} (\tan \phi_P \cos \gamma_P - \sin \psi_P \sin \gamma_P)$
	Driven member $F_{aG} = \frac{F_{tG}}{\cos \psi_G} (\tan \phi_G \sin \gamma_G + \sin \psi_G \cos \gamma_G)$	Driven member $F_{sG} = \frac{F_{tG}}{\cos \psi_G} (\tan \phi_G \cos \gamma_G - \sin \psi_G \sin \gamma_G)$
Right hand spiral counterclockwise or Left hand spiral clockwise	Driving member $F_{aP} = \frac{F_{tP}}{\cos \psi_P} (\tan \phi_P \sin \gamma_P + \sin \psi_P \cos \gamma_P)$	Driving member $F_{sP} = \frac{F_{tP}}{\cos \psi_P} (\tan \phi_P \cos \gamma_P + \sin \psi_P \sin \gamma_P)$
	Driven member $F_{aG} = \frac{F_{tG}}{\cos \psi_G} (\tan \phi_G \sin \gamma_G - \sin \psi_G \cos \gamma_G)$	Driven member $F_{sG} = \frac{F_{tG}}{\cos \psi_G} (\tan \phi_G \cos \gamma_G + \sin \psi_G \sin \gamma_G)$

## STRAIGHT WORM GEARING

### WORM

#### Tangential force

$$F_{tW} = \frac{(1.91 \times 10^7) H}{D_{PW} n_W} \quad (\text{newtons})$$

$$= \frac{(1.26 \times 10^5) H}{D_{pW} n_W} \quad (\text{pounds-force})$$

#### Thrust force

$$F_{aW} = \frac{(1.91 \times 10^7) H \eta}{D_{pG} n_G} \quad (\text{newtons})$$

$$= \frac{(1.26 \times 10^5) H \eta}{D_{pG} n_G} \quad (\text{pounds-force})$$

or

$$F_{aW} = \frac{F_{tW} \eta}{\tan \lambda}$$

#### Separating force

$$F_{sW} = \frac{F_{tW} \sin \phi}{\cos \phi \sin \lambda + \mu \cos \lambda}$$

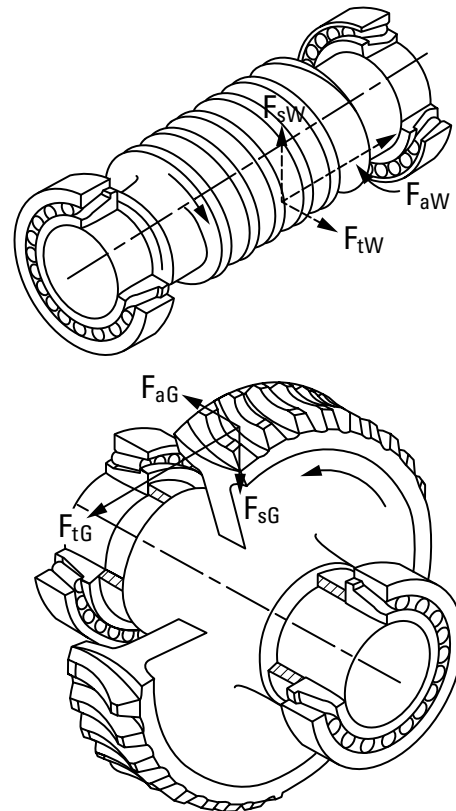

Fig. 42. Straight worm gearing.



**WORM GEAR****TANGENTIAL FORCE**

$$F_{tG} = \frac{(1.91 \times 10^7) H \eta}{D_{pG} n_G} \quad (\text{newtons})$$

$$= \frac{(1.26 \times 10^5) H \eta}{D_{pG} n_G} \quad (\text{pounds-force})$$

or

$$F_{tG} = \frac{F_{tW} \eta}{\tan \lambda}$$

**THRUST FORCE**

$$F_{aG} = \frac{(1.91 \times 10^7) H}{D_{pW} n_W} \quad (\text{newtons})$$

$$= \frac{(1.26 \times 10^5) H}{D_{pW} n_W} \quad (\text{pounds-force})$$

**SEPARATING FORCE**

$$F_{sG} = \frac{F_{tW} \sin \Phi}{\cos \Phi \sin \lambda + \mu \cos \lambda}$$

Where:

$$\lambda = \tan^{-1} \left( \frac{D_{pG}}{m D_{pW}} \right)$$

or

$$\lambda = \tan^{-1} \left( \frac{L_H}{\pi D_{pW}} \right)$$

and

$$\eta = \frac{\cos \Phi - \mu \tan \lambda}{\cos \Phi + \mu \cot \lambda}$$

**METRIC SYSTEM**

$$\mu^{(1)} = (5.34 \times 10^{-7}) V_r^3 + \frac{0.146}{V_r^{0.09}} - 0.103$$

$$V_r = \frac{D_{pW} n_W}{(1.91 \times 10^4) \cos \lambda} \quad (\text{meters per second})$$

**INCH SYSTEM**

$$\mu^{(1)} = (7 \times 10^{-14}) V_r^3 + \frac{0.235}{V_r^{0.09}} - 0.103$$

$$V_r = \frac{D_{pW} n_W}{3.82 \cos \lambda} \quad (\text{feet per minute})$$

<sup>(1)</sup>Approximate coefficient of friction for the 0.015 to 15 m/s (3 to 3000 ft/min) rubbing velocity range.

**DOUBLE ENVELOPING WORM GEARING****TANGENTIAL FORCE**

$$F_{tW} = \frac{(1.91 \times 10^7) H}{D_{mW} n_W} \quad (\text{newtons})$$

$$= \frac{(1.26 \times 10^5) H}{D_{mW} n_W} \quad (\text{pounds-force})$$

**THRUST FORCE**

$$F_{aW} = 0.98 F_{tG}$$

Use this value for  $F_{tG}$  for bearing loading calculations on worm gear shaft. For torque calculations, use the following  $F_{tG}$  equations.

**SEPARATING FORCE**

$$F_{sW} = \frac{0.98 F_{tG} \tan \Phi}{\cos \lambda}$$

**WORM GEAR****TANGENTIAL FORCE**

$$F_{tG} = \frac{(1.91 \times 10^7) H m \eta}{D_{pG} n_W} \quad (\text{newtons})$$

$$= \frac{(1.26 \times 10^5) H m \eta}{D_{pG} n_W} \quad (\text{pounds-force})$$

or

$$F_{tG} = \frac{(1.91 \times 10^7) H \eta}{D_{pG} n_G} \quad (\text{newtons})$$

$$= \frac{(1.26 \times 10^5) H \eta}{D_{pG} n_G} \quad (\text{pounds-force})$$

Use this value for calculating torque in subsequent gears and shafts. For bearing loading calculations, use the equation for  $F_{aW}$ .

**THRUST FORCE**

$$F_{aG} = \frac{(1.91 \times 10^7) H}{D_{mW} n_W} \quad (\text{newtons})$$

$$= \frac{(1.26 \times 10^5) H}{D_{mW} n_W} \quad (\text{pounds-force})$$

**SEPARATING FORCE**

$$F_{sG} = \frac{0.98 F_{tG} \tan \Phi}{\cos \lambda}$$

Where:

$\eta$  = efficiency (refer to manufacturer's catalog)

$$D_{mW} = 2d_c - 0.98 D_{pG}$$

Lead angle at center of worm:

$$\lambda = \tan^{-1} \left( \frac{D_{pG}}{m D_{pW}} \right) = \tan^{-1} \left( \frac{L}{\pi D_{pW}} \right)$$

## BELT AND CHAIN DRIVE FACTORS

Due to the variations of belt tightness as set by various operators, an exact equation relating total belt pull to tension  $F_1$  on the tight side and tension  $F_2$  on the slack side (Fig. 43) is difficult to establish. The following equation and Table 5 may be used to estimate the total pull from various types of belt and pulley, and chain and sprocket designs:

$$F_b = \frac{(1.91 \times 10^7) H f_B}{D_m n} \quad (\text{newtons})$$

$$= \frac{(1.26 \times 10^5) H f_B}{D_m n} \quad (\text{pounds-force})$$

Standard roller chain sprocket mean diameter.

$$D_m = \frac{P}{\sin\left(\frac{180}{N_s}\right)}$$

Where:

$P$  = chain pitch

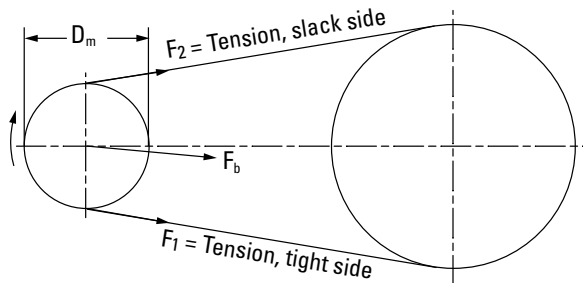

Fig. 43. Belt or chain drive.

TABLE 4.  
BELT OR CHAIN PULL FACTOR  
BASED ON 180 DEGREE ANGLE OF WRAP

Type	$f_B$
Chains, single	1.00
Chains, double	1.25
"V" belts	1.50

## SHAFT ON TWO SUPPORTS

Simple beam equations are used to translate the externally applied forces on a shaft into bearing reactions acting at the bearing effective centers.

With two-row tapered roller and angular contact ball bearings, the geometric center of the bearing is considered to be the support point except where the thrust force is large enough to unload one row. Then the effective center of the loaded row is used as the point from which bearing load reactions are calculated. These approaches approximate the load distribution within a two-row bearing, assuming rigid shaft and housing. These are statically indeterminate problems in which shaft and support rigidity can significantly influence bearing loading and require the use of computer programs to solve.

## SHAFT ON THREE OR MORE SUPPORTS

The equations of static equilibrium are insufficient to solve bearing reactions on a shaft having more than two supports. Such cases can be solved using computer programs if adequate information is available.

In such problems, the deflections of the shaft, bearings and housings affect the distribution of loads. Any variance in these parameters can significantly affect bearing reactions.

Bearing radial loads are determined by:

- Resolving forces applied to the shaft into horizontal and vertical components, relative to a convenient reference plane.
- Taking moments about the opposite support.
- Combining the horizontal and vertical reactions at each support into one resultant load.

Shown (on the next page) are equations for the case of a shaft on two supports with gear forces  $F_t$  (tangential),  $F_s$  (separating), and  $F_a$  (thrust), an external radial load  $F$ , and an external moment  $M$ . The loads are applied at arbitrary angles (1, 2, and 3) relative to the reference plane indicated in Fig. 44 on the following page. Using the principle of superposition, the equations for vertical and horizontal reactions ( $F_{rv}$  and  $F_{rh}$ ) can be expanded to include any number of gears, external forces or moments. Use signs as determined from gear force equation.

Care should be used when doing this to ensure proper supporting degrees of freedom are used. That is, tapered roller bearings and ball bearings support radial loads, moment loads and axial loads in both directions.

## BEARING REACTIONS

TABLE 5.  
CALCULATION EQUATIONS

Symbols Used		
ae	Effective bearing spread	mm, in.
A, B, ...	Bearing position, used as subscripts	
C <sub>1</sub> , C <sub>2</sub> , ...	Linear distance (positive or negative)	mm, in.
DpG	Pitch diameter of the gear	mm, in.
F	Applied force	N, lbf
F <sub>r</sub>	Radial bearing load	N, lbf
h	Horizontal (used as subscript)	
M	Moment	N-mm, lbf-in.
v	Vertical (used as subscript)	
1	Gear mesh angle relative to plane of reference defined in the figure below	deg, rad
2	Angle of applied force relative to plane of reference defined in the figure below	deg, rad
3	Angle of applied moment relative to plane of reference defined in the figure below	deg, rad

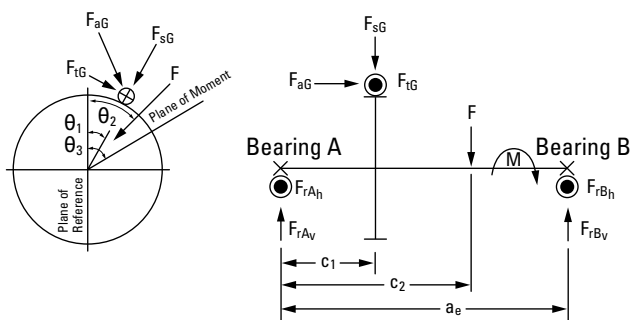

Fig. 44. Bearing radial reactions.

Vertical reaction component at bearing position B:

$$F_{rBv} = \frac{1}{a_e} \left( c_1 (F_{sG} \cos \theta_1 + F_{tG} \sin \theta_1) + \frac{1}{2} (D_{pG} - b \sin \gamma_G) F_{aG} \cos \theta_1 + c_2 F \cos \theta_2 + M \cos \theta_3 \right)$$

Horizontal reaction component at bearing position B:

$$F_{rBh} = \frac{1}{a_e} \left( c_1 (F_{sG} \sin \theta_1 - F_{tG} \cos \theta_1) + \frac{1}{2} (D_{pG} - b \sin \gamma_G) F_{aG} \sin \theta_1 + c_2 F \sin \theta_2 + M \sin \theta_3 \right)$$

Vertical reaction component at bearing position A:

$$F_{rAv} = F_{sG} \cos \theta_1 + F_{tG} \sin \theta_1 + F \cos \theta_2 - F_{rBv}$$

Horizontal reaction component at bearing position A:

$$F_{rAh} = F_{sG} \sin \theta_1 - F_{tG} \cos \theta_1 + F \sin \theta_2 - F_{rBh}$$

Resultant radial reaction:  $F_{rA} = [(F_{rAv})^2 + (F_{rAh})^2]^{1/2}$       $F_{rB} = [(F_{rBv})^2 + (F_{rBh})^2]^{1/2}$

Resultant axial reaction:  $F_{aA} = F_{aG}$  (fixed position)      $F_{aB} = 0$  (float position)

## CENTRIFUGAL FORCE

Centrifugal force resulting from imbalance in a rotating member:

$$F_c = \frac{F_w r n^2}{8.94 \times 10^5} \quad (\text{newtons})$$

$$= \frac{F_w r n^2}{3.52 \times 10^4} \quad (\text{pounds-force})$$

## SHOCK LOADS

It is difficult to determine the exact effect that shock loading has on bearing life. The magnitude of the shock load depends on the masses of the colliding bodies, their velocities, and deformations at impact.

The effect on the bearing depends on how much of the shock is absorbed between the point of impact and the bearings, as well as whether the shock load is great enough to cause bearing damage. It also is dependent on frequency and duration of shock loads.

At a minimum, a suddenly applied load is equivalent to twice its static value. It may be considerably more than this, depending on the velocity of impact.

Shock involves a number of variables that generally are not known or easily determined. Therefore, it is good practice to rely on experience. The Timken Company has years of experience with many types of equipment under the most severe loading conditions. Your Timken representative should be consulted on any application involving unusual loading or service requirements.

## LOAD RATINGS

The basic dynamic load rating and the static load rating are commonly used for bearing selection. The basic dynamic load rating is used to estimate life of a rotating bearing. Static load ratings are used to determine the maximum permissible load that can be applied to a non-rotating bearing.

The basic philosophy of The Timken Company is to provide the most realistic bearing rating to assist our customers in the bearing selection process. Published ratings for Timken bearings include the basic dynamic radial load ratings, C1, for tapered roller bearings, and Ce for ball bearings. These values are based on a basic rating life of one million revolutions. Timken tapered roller bearings also include the basic dynamic load rating C90, which is based on a basic rating life of ninety million revolutions. The basic static radial load rating is Co.

### STATIC LOAD RATING

The basic static radial load ratings for Timken bearings are based on a maximum contact stress within a non-rotating bearing of 4000 MPa (580 ksi) for roller bearings and 4200 MPa (609 ksi) for ball bearings, at the center of contact on the most heavily loaded rolling element.

The 4000 MPa (580 ksi) or 4200 MPa (609 ksi) stress levels may cause visible light Brinell marks on the bearing raceways. This degree of marking will not have a measurable effect on fatigue life when the bearing is subsequently rotating under a lower-application load. If sound, vibration or torque are critical, or if a pronounced shock load is present, a lower load limit should be applied.

**TABLE 6.**  
**HARDNESS FACTORS TO MODIFY BASIC STATIC LOAD RATING**

Raceway Hardness HRC	Hardness Factor HFs
58	1.00
57	1.06
56	1.13
55	1.21
54	1.29
53	1.37
52	1.46
51	1.55
50	1.65
49	1.76
48	1.88
47	2.00
46	2.13
45	2.27
44	2.41
43	2.57
42	2.74
41	2.92
40	3.10

When the loading is static, it is usually suggested that the applied load be no greater than the basic static load rating divided by the appropriate hardness factor (HFs) as shown in Table 6.

For more information on selecting a bearing for static load conditions, consult your Timken representative.

### STATIC RADIAL AND/OR AXIAL EQUIVALENT LOADS

The static equivalent radial and/or axial loading is dependent on the bearing type selected. For bearings designed to accommodate only radial or axial loading, the static equivalent load is equivalent to the applied load.

For all bearings, the maximum contact stress can be approximated using the static equivalent load and the static rating.

For roller bearings:

$$\sigma_0 = 4000 \times \left( \frac{P_0}{C_0} \right)^{1/2} \text{ MPa}$$

$$\sigma_0 = 580 \times \left( \frac{P_0}{C_0} \right)^{1/2} \text{ ksi}$$

For ball bearings:

$$\sigma_0 = 4200 \times \left( \frac{P_0}{C_0} \right)^{1/3} \text{ MPa}$$

$$\sigma_0 = 609 \times \left( \frac{P_0}{C_0} \right)^{1/3} \text{ ksi}$$

#### Radial ball bearings

The dynamic equivalent radial load is used for comparison with the static load rating.

$$P_{0r} = 1/2 C_0$$

#### Thrust ball bearings

Similar to radial ball bearings, thrust ball bearings use the same equation for equivalent static and dynamic loading.

$$P_{0a} = XF_r + YF_a$$

The X and Y factors are listed later in this section along with the minimum required axial load-to-radial load ratio for maintaining proper operation.

#### Tapered roller bearings

To determine the static equivalent radial load for a single-row mounting, first determine the axial load (F<sub>a</sub>), then use the following equations, depending on the appropriate axial load condition.

Where: F<sub>r</sub> = applied radial load

F<sub>a</sub> = net bearing axial load. F<sub>aA</sub> and F<sub>aB</sub> calculated from equations

**TABLE 7.**  
**STATIC EQUIVALENT LOAD EQUATIONS, SINGLE-ROW TAPERED ROLLER BEARING**

Design	Thrust Condition	Axial Load	Static Equivalent Radial Load
	$\frac{0.47 F_{rA}}{K_A} \leq \frac{0.47 F_{rB}}{K_B} + F_{ae}$	$F_{aA} = \frac{0.47 F_{rB}}{K_B} + F_{ae}$ $F_{aB} = \frac{0.47 F_{rB}}{K_B}$	$P_{OB} = F_{rB}$ for $F_{aA} < 0.6 F_{rA} / K_A$ $P_{OA} = 1.6 F_{rA} - 1.269 K_A F_{aA}$ for $F_{aA} < 0.6 F_{rA} / K_A$ $P_{OA} = 0.5 F_{rA} + 0.564 K_A F_{aA}$
<p>Design (external axial load, <math>F_{ae}</math>, onto bearing A)</p>	$\frac{0.47 F_{rA}}{K_A} > \frac{0.47 F_{rB}}{K_B} + F_{ae}$	$F_{aA} = \frac{0.47 F_{rA}}{K_A}$ $F_{aB} = \frac{0.47 F_{rA}}{K_A} - F_{ae}$	for $F_{aB} < 0.6 F_{rB} / K_B$ $P_{OB} = 0.5 F_{rB} + 0.564 K_B F_{aB}$ for $F_{aB} < 0.6 F_{rB} / K_B$ $P_{OB} = 1.6 F_{rB} - 1.269 K_B F_{aB}$ $P_{OA} = F_{rA}$

Use the values of  $P_O$  calculated for comparison with the static rating ( $C_O$ ), even if  $P_O$  is less than the radial applied  $F_r$ .

**Static Equivalent Radial Load (Two-Row Bearings)**

The bearing data tables do not include static rating for two-row bearings. The two-row static radial rating can be estimated as:

$$C_{O(2)} = 2C_O$$

Where:

- $C_{O(2)}$  = two-row static radial rating
- $C_O$  = static radial load rating of a single-row bearing, type TS, from the same series.

**Dynamic Equivalent Radial Bearing Loads ( $P_r$ )**

To calculate the L10 life, it is necessary to calculate a dynamic equivalent radial load, designated by  $P_r$ . The dynamic equivalent radial load is defined as a single radial load that, if applied to the bearing, will result in the same life as the combined loading under which the bearing operates.

$$P_r = XF_r + YF_a$$

Where:

- $P_r$  = dynamic equivalent radial load
- $F_r$  = applied radial load
- $F_a$  = applied axial load
- $X$  = radial load factor
- $Y$  = axial load factor

Tapered roller bearings use the equations based on the number of rows and type of mounting utilized. For single-row bearings in direct or indirect mounting, the figure on page 31 can be used based on the direction of the externally applied axial load. Once the appropriate design is chosen, review the table and check the thrust condition

to determine which axial load and dynamic equivalent radial load calculations apply. For ball bearings, the dynamic equivalent radial load can be found in the table below.

**TABLE 8.**  
**DYNAMIC EQUIVALENT LOAD EQUATIONS**

Bearing Description (ref.)	Contact Angle	Single-Row and Tandem Mountings	Double-Row and Preload Pair Mountings
Bearing type and or series		$K_T = \frac{F_a}{(\# \text{ of bearings}) \times C_O}$	$K_T =$
Radial type ball bearings – use larger of resulting “ $P_r$ ” value <sup>(1)</sup>			
MM9300K MM9100K MM200K MM300K	0°	$P_r = F_r$ or $P_r = 0.56F_r + Y_1F_a$	$P_r = F_r + 1.20Y_1F_a$ or $P_r = 0.78F_r + F_{a1} \cdot 1.625Y_1F_a / C_O$
Angular contact ball bearings – use larger of resulting “ $P_r$ ” value			
2MMV9300WI 2MMV9300HX 2MM9300WI 2MV9300WI 2MMV9100WI 2MMV9100HX 2MM99100WI 2MM9100WI 2MV9100WI 2MV200WI 2MMV200WI 2MMV300WI 2MM200WI 2MM300WI 2MV300WI	15°	$P_r = F_r$ or $P_r = 0.44F_r + Y_2F_a$	$P_r = F_r + 1.124Y_2F_a$ or $P_r = 0.72F_r + 1.625Y_2F_a$
2MM9100WO	15°	$P_r = F_r$ or $P_r = 0.44F_r + Y_3F_a$	$P_r = F_r + 1.124Y_3F_a$ or $P_r = 0.72F_r + 1.625Y_3F_a$
3MMV9300WI 3MMV9300HX 3MM9300WI 3MV9300WI 3MMV9100WI 3MMV9100HX 3MM9100WI 3MV9100WI 3MM99100WI 3MMV200WI 3MV200WI 3MM200WI 3MM300WI 3MV300WI 3MV300WI	25°	$P_r = F_r$ or $P_r = 0.41F_r + 0.87F_a$	$P_r = F_r + 0.92F_a$ or $P_r = 0.67F_r + 1.41F_a$

<sup>(1)</sup>If  $P_r > C_O$  or  $P_r > 1/2 C_e$  consult with your Timken representative on Life Calculations.

**TABLE 9.**  
**THE REQUIRED Y FACTORS FOR BALL BEARINGS**

$K_T$	$Y_1$	$Y_2$	$Y_3$
0.015	2.30	1.47	1.60
0.020	2.22	1.44	1.59
0.025	2.10	1.41	1.57
0.030	2.00	1.39	1.56
0.040	1.86	1.35	1.55
0.050	1.76	1.32	1.53
0.060	1.68	1.29	1.51
0.080	1.57	1.25	1.49
0.100	1.48	1.21	1.47
0.120	1.42	1.19	1.45
0.150	1.34	1.14	1.42
0.200	1.25	1.09	1.39
0.250	1.18	1.05	1.35
0.300	1.13	1.02	1.33
0.400	1.05	1.00	1.29
0.500	1.00	1.00	1.25
0.600	—	—	1.22
0.800	—	—	1.17
1.000	—	—	1.13
1.200	—	—	1.10

**Dynamic Equivalent Axial Bearing Loads ( $P_a$ )**

For thrust ball and thrust tapered roller bearings, the existence of radial loads introduces complex load calculations that must be carefully considered. If radial load is zero, the dynamic equivalent axial load ( $P_a$ ) will be equal to the applied axial load ( $F_a$ ). If any radial load is expected in the application, consult your Timken representative for advice on bearing selection.

For thrust angular contact ball bearings, the dynamic equivalent axial load is determined by:

$$P_a = XF_r + YF_a$$

When:  $\frac{F_a}{F_r} < 2.17$        $X = 1.90$     $Y = 0.54$

When:  $\frac{F_a}{F_r} > 2.17$        $X = 0.92$     $Y = 1.00$

If:  $\frac{F_a}{F_r} \leq 2.17$  then bearings with a contact angle  $< 60^\circ$  should be considered.

**BEARING EQUIVALENT LOADS AND REQUIRED RATINGS FOR TAPERED ROLLER BEARINGS**

Tapered roller bearings are ideally suited to carry all types of loads – radial, axial, and any combination of both. Due to the tapered design of the bearing, a radial load will induce an axial reaction within the bearing that must be opposed by an equal or greater axial load to keep the bearing cone and cup from separating. The ratio of the radial to the axial load and the bearing included cup angle determine the load zone in a given bearing. The number of rollers in contact as a result of this ratio determines the load zone in the bearing. If all the rollers are in contact, the load zone is referred to as being 360 degrees.

When only radial load is applied to a tapered roller bearing, for convenience it is assumed in using the traditional calculation method that half the rollers support the load – the load zone is 180 degrees. In this case, induced bearing axial load is:

$$F_{a(180)} = \frac{0.47}{K}$$

The equations for determining bearing axial reactions and equivalent radial loads in a system of two single-row bearings are based on the assumption of a 180-degree load zone in one of the bearings and 180 degrees or more in the opposite bearing.

**Dynamic Equivalent Radial Load**

The basic dynamic radial load rating,  $C_{90}$ , is assumed to be the radial load-carrying capacity with a 180-degree load zone in the bearing. When the axial load on a bearing exceeds the induced thrust,  $F_{a(180)}$ , a dynamic equivalent radial load must be used to calculate bearing life.

The dynamic equivalent radial load is that radial load which, if applied to a bearing, will give the same life as the bearing will attain under the actual loading.

The equations presented give close approximations of the dynamic equivalent radial load assuming a 180-degree load zone in one bearing and 180 degrees or more in the opposite bearing.

Tapered roller bearings use the equations based on the number of rows and type of mounting utilized. For single-row bearings in direct or indirect mounting, the following table can be used based on the direction of the externally applied axial load. Once the appropriate design is chosen, review the table and check the thrust condition to determine which axial load and dynamic equivalent radial load calculations apply.



### ALTERNATE APPROACH FOR DETERMINING DYNAMIC EQUIVALENT RADIAL LOADS

The following is a general approach to determining the dynamic equivalent radial loads. Here, a factor "m" has to be defined as +1 for direct-mounted single-row or two-row bearings, or -1 for indirect mounted bearings. Also, a sign convention is necessary for the external axial load  $F_{ae}$  as follows:

- In case of external axial load applied to the shaft (typical rotating cone application),  $F_{ae}$  to the right is positive; to the left is negative.
- When external axial load is applied to the housing (typical rotating cup application),  $F_{ae}$  to the right is negative; to the left is positive.

**TABLE 10.**  
**DYNAMIC EQUIVALENT RADIAL LOAD EQUATIONS, SINGLE-ROW TAPERED ROLLER BEARING MOUNTING**

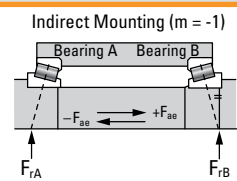
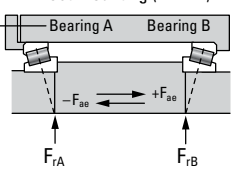
Design	Thrust Condition	Axial Load	Dynamic Equivalent Radial Load
 <p>Indirect Mounting (<math>m = -1</math>)</p>	$\frac{0.47 \times F_{rA}}{K_A} \leq \frac{0.47 \times F_{rB}}{K_B} - m F_{ae}$	$F_{aA} = \frac{0.47 \times F_{rB}}{K_B} - m F_{ae}$ $F_{aB} = \frac{0.47 \times F_{rB}}{K_B}$	$P_A = 0.4 F_{rA} + K_A F_{aA}$ $P_B = F_{rB}$
 <p>Direct Mounting (<math>m = +1</math>)</p>	$\frac{0.47 \times F_{rA}}{K_A} > \frac{0.47 \times F_{rB}}{K_B} - m F_{ae}$	$F_{aA} = \frac{0.47 \times F_{rA}}{K_A}$ $F_{aB} = \frac{0.47 \times F_{rA}}{K_A} + m F_{ae}$	$P_A = F_{rA}$ $P_B = 0.4 F_{rB} + K_B F_{aB}$

If  $P_A < F_{rA}$ , use  $P_A = F_{rA}$  or if  $P_B < F_{rB}$ , use  $P_B = F_{rB}$ .

**TABLE 11.**  
**DYNAMIC EQUIVALENT RADIAL LOAD EQUATIONS, TWO-ROW TAPERED ROLLER BEARING MOUNTING – FIXED BEARING WITH EXTERNAL AXIAL LOAD,  $F_{ae}$  (SIMILAR OR DISSIMILAR SERIES)**

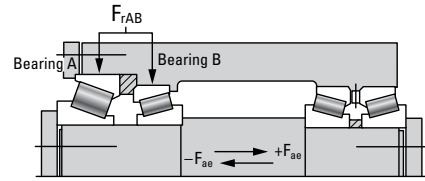
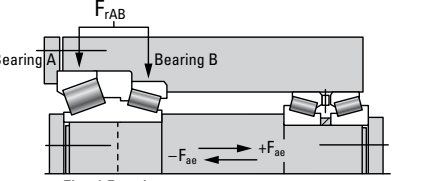
Design	Thrust Condition	Dynamic Equivalent Radial Load
 <p>Fixed Bearing Indirect Mounting (<math>m = -1</math>)</p>	$F_{ae} \leq \frac{0.6 \times F_{rAB}}{K^{(1)}}$	$P_A = \frac{K_A}{K_A + K_B} (F_{rAB} - 1.67 m K_B F_{ae})$ $P_B = \frac{K_B}{K_A + K_B} (F_{rAB} + 1.67 m K_A F_{ae})$
 <p>Fixed Bearing Direct Mounting (<math>m = +1</math>)</p>	$F_{ae} > \frac{0.6 \times F_{rAB}}{K^{(1)}}$	$P_A = 0.4 F_{rAB} - m K_A F_{ae}$ $P_B = 0.4 F_{rAB} + m K_B F_{ae}$

<sup>(1)</sup>If "m  $F_{ae}$ " is positive,  $K = K_A$ ; If "m  $F_{ae}$ " is negative,  $K = K_B$ .

$F_{rAB}$  is the radial load on the two-row assembly. The single-row basic dynamic radial load rating,  $C_{90}$ , is to be applied when calculating life based on the above equations.

## BEARING LIFE AND SYSTEM LIFE

Many different performance criteria exist that dictate how a bearing should be selected. These include bearing fatigue life, rotational precision, power requirements, temperature limits, speed capabilities, sound, etc. This publication deals primarily with bearing life as related to material-associated fatigue. Bearing life is defined here as the length of time, or number of revolutions, until a fatigue spall of 6.0 mm<sup>2</sup> (0.01 in.<sup>2</sup>) develops. Since metal fatigue is a statistical phenomenon, the life of an individual bearing is impossible to predetermine precisely. Bearings that may appear to be identical can exhibit considerable life scatter when tested under identical conditions. Thus it is necessary to base life predictions on a statistical evaluation of a large number of bearings operating under similar conditions. The Weibull distribution function is commonly used to predict the life of a population of bearings at any given reliability level.

### RATING LIFE

Rating life, (L<sub>10</sub>), is the life that 90 percent of a group of apparently identical bearings will complete or exceed before a fatigue spall develops. The L<sub>10</sub> life also is associated with 90 percent reliability for a single bearing under a certain load.

### BEARING LIFE EQUATIONS

Traditionally, the L<sub>10</sub> life has been calculated as follows for bearings under radial or combined loading where the dynamic equivalent radial load, (P<sub>r</sub>), has been determined:

$$L_{10} = \left( \frac{C}{P_r} \right)^e \times (1 \times 10^6) \quad \text{revolutions}$$

or,

$$L_{10} = \left( \frac{C}{P_r} \right)^e \times \left( \frac{1 \times 10^6}{60n} \right) \quad \text{hours}$$

For thrust bearings, the above equations change to the following.

$$L_{10} = \left( \frac{C_a}{P_a} \right)^e \times (1 \times 10^6) \quad \text{revolutions}$$

or,

$$L_{10} = \left( \frac{C_a}{P_a} \right)^e \times \left( \frac{1 \times 10^6}{60n} \right) \quad \text{hours}$$

$$e = 3 \text{ for ball bearings}$$

$$= 10/3 \text{ for roller bearings}$$

Tapered roller bearings often use a dynamic load rating based on ninety million cycles, as opposed to one million cycles, changing the equations as follows.

$$L_{10} = \left( \frac{C_{90}}{P_r} \right)^{10/3} \times (90 \times 10^6) \quad \text{revolutions}$$

or,

$$L_{10} = \left( \frac{C_{90}}{P_r} \right)^{10/3} \times \left( \frac{90 \times 10^6}{60n} \right) \quad \text{hours}$$

and

$$L_{10} = \left( \frac{C_{a90}}{P_a} \right)^{10/3} \times (90 \times 10^6) \quad \text{revolutions}$$

or,

$$L_{10} = \left( \frac{C_{a90}}{P_a} \right)^{10/3} \times \left( \frac{90 \times 10^6}{60n} \right) \quad \text{hours}$$

As the first set of equations for radial bearings with dynamic ratings based on one million revolutions is the most common form of the equations, this will be used through the rest of this section. The dynamic equivalent load equations and the life adjustment factors are applicable to all forms of the life equation.

With increased emphasis on the relationship between the reference conditions and the actual environment in which the bearing operates in the machine, the traditional life equations have been expanded to include certain additional variables that affect bearing performance. The approach whereby these factors, including a factor for useful life, are considered in the bearing analysis and selection has been termed Bearing Systems Analysis (BSA).

The ISO/ABMA adjusted bearing life equation is:

$$L_{na} = a_1 a_2 a_3 L_{10}$$

Where:

- a<sub>1</sub> = reliability life factor
- a<sub>2</sub> = material life factor
- a<sub>3</sub> = operating condition life factor  
(to be specified by the manufacturer)

The Timken adjusted bearing life equation is:

$$L_{na} = a_1 a_2 a_{3d} a_{3h} a_{3k} a_{3l} a_{3m} a_{3p} \left( \frac{C}{P_r} \right)^e (1 \times 10^6) \quad \text{revolutions}$$

Where:

- a<sub>1</sub> = reliability life factor
- a<sub>2</sub> = material life factor
- a<sub>3d</sub> = debris life factor
- a<sub>3h</sub> = hardness life factor
- a<sub>3k</sub> = load zone life factor
- a<sub>3l</sub> = lubrication life factor
- a<sub>3m</sub> = misalignment life factor
- a<sub>3p</sub> = low load life factor
- C = dynamic radial load rating
- P<sub>r</sub> = dynamic equivalent radial load
- e = 3 for ball bearings  
= 10/3 for roller bearings

## RELIABILITY LIFE FACTOR ( $a_1$ )

The equation for the life adjustment factor for reliability is:

$$a_1 = 4.26 \times \left( \ln \frac{100}{R} \right)^{2/3} + 0.05$$

ln = natural logarithm (base e)

To adjust the calculated  $L_{10}$  life for reliability, multiply by the  $a_1$  factor. If 90 (90 percent reliability) is substituted for R in the above equation,  $a_1 = 1$ . For R = 99 (99 percent reliability),  $a_1 = 0.25$ . The following table lists the reliability factor for commonly used reliability values.

**TABLE 12.**  
**RELIABILITY FACTORS**

R (percent)	$L_n$	$a_1$
90	$L_{10}$	1.00
95	$L_5$	0.64
96	$L_4$	0.55
97	$L_3$	0.47
98	$L_2$	0.37
99	$L_1$	0.25
99.5	$L_{0.5}$	0.175
99.9	$L_{0.1}$	0.093

Note that the equation for reliability adjustment assumes there is a short minimum life below which the probability of bearing damage is minimal (e.g., zero probability of bearing damage producing a short life). Extensive bearing fatigue life testing has shown the minimum life, below which the probability of bearing damage is negligible, to be larger than shown above. For a more accurate prediction of bearing lives at high levels of reliability, consult your Timken representative.

## MATERIAL LIFE FACTOR ( $a_2$ )

The life adjustment factor for bearing material ( $a_2$ ) for standard Timken bearings manufactured from bearing-quality steel is 1.0. Bearings also are manufactured from premium steels, containing fewer and smaller inclusion impurities than standard steels and providing the benefit of extending bearing fatigue life (e.g., DuraSpexx™). Application of the material life factor requires that fatigue life is limited by nonmetallic inclusions, that contact stresses are approximately less than 2400 MPa (350 ksi), and adequate lubrication is provided. It is important to note that improvements in material cannot offset poor lubrication in an operating bearing system. Consult your Timken representative for applicability of the material factor.

## DEBRIS LIFE FACTOR ( $a_{3d}$ )

Debris within a lubrication system reduces the life of a rolling bearing by creating indentations on the contacting surfaces, leading to stress risers. The Timken life rating equations were developed based on test data obtained with 0.040 mm (0.00157 in.) oil filtration and measured ISO cleanliness levels of approximately 15/12, which is typical of cleanliness levels found in normal industrial machinery. When more or less debris is present within the system, the fatigue life predictions can be adjusted according to the measured or expected ISO lubricant cleanliness level to more accurately reflect the expected bearing performance.

As opposed to determining the debris life factor based on filtration and ISO cleanliness levels, a Debris Signature Analysis™ can be performed for more accurate bearing performance predictions. The Debris Signature Analysis is a process for determining the effects of the actual debris present in your system on the bearing performance. The typical way in which this occurs is through measurements of dented/bruised surfaces on actual bearings run in a given application. This type of analysis can be beneficial because different types of debris cause differing levels of performance, even when they are of the same size and amount in the lubricant. Soft, ductile particles can cause less performance degradation than hard, brittle particles. Hard, ductile particles are typically most detrimental to bearing life. Brittle particles can break down, thus not affecting performance to as large a degree as hard ductile particles. For more information on Debris Signature Analysis or the availability of Debris Resistant bearings for your application, consult your Timken representative.

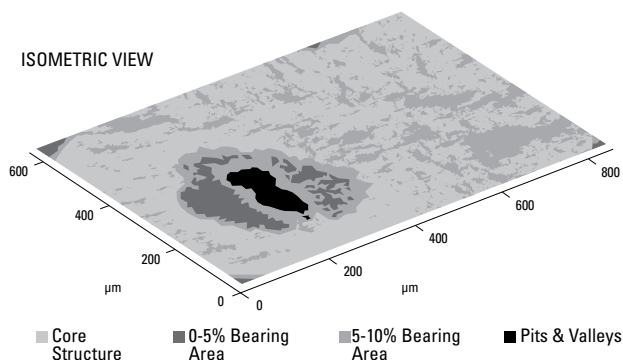

**Fig. 45.** Surface map of a bearing raceway with debris denting.

### HARDNESS LIFE FACTOR ( $a_{3h}$ )

For Timken bearings in this catalog, supplied as a full assembly, the hardness life factor will be one <sup>(1)</sup>.

### LOAD ZONE LIFE FACTOR ( $a_{3k}$ )

The fatigue life of a bearing is a function of the stresses in rolling elements and raceways and the number of stress cycles that the loaded bearing surfaces experience in one bearing revolution. The stresses depend on applied load and on how many rolling elements support that load. The number of stress cycles depends on bearing geometry and, again, on how many rolling elements support the load. Therefore, life for a given external load is related to the loaded arc or load zone of the bearing.

The load zone in a bearing is dominated by the internal clearance, either radial or axial depending on the bearing type. Without considering preload, less clearance in a bearing results in a larger load zone and subsequently longer bearing life.

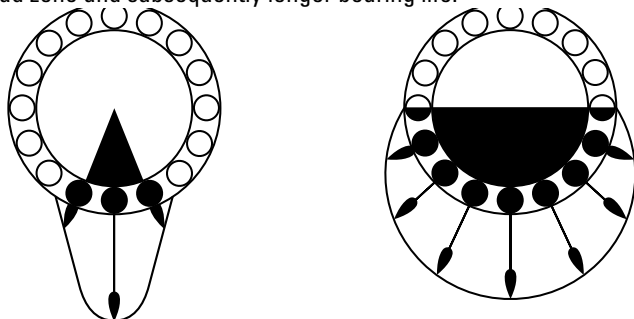

**Fig. 46. Bearing load zones and rolling element-raceway contact loading.**

Using the dynamic equivalent load ( $P_r$ ) instead of the applied radial load ( $F_r$ ) in the equation for  $L_{10a}$  roughly approximates the load zone factor for combined loading only. If a more accurate assessment of the load zone adjusted life is necessary (e.g., including the effects of internal clearance or fitting practice), consult your Timken representative.

### LUBRICATION LIFE FACTOR ( $a_{3l}$ )

The influence of lubrication film due to elastohydrodynamic (EHL) lubrication on bearing performance is related to the reduction or prevention of asperity (metal-metal) contact between the bearing surfaces. Extensive testing was done at the Timken Technology Center to quantify the effects of the lubrication-related parameters on bearing life. It was found that the rolling element and raceway surface finish, relative to lubricant film thickness, has the most notable effect on improving bearing performance. Factors such as bearing geometry, material, loads and load zones also play an important role in bearing performance.

The following equation provides a method to calculate the lubrication factor for a more accurate prediction of the influence of lubrication on tapered roller bearing life ( $L_{10a}$ ). For more information on calculating this factor for ball bearings, consult your Timken representative.

$$a_{3l} = C_g \times C_l \times C_j \times C_s \times C_v \times C_{gr}$$

Where:

- $C_g$  = geometry factor
- $C_l$  = load factor
- $C_j$  = load zone factor
- $C_s$  = speed factor
- $C_v$  = viscosity factor
- $C_{gr}$  = grease lubrication factor

**The  $a_{3l}$  maximum is 2.88 for all bearings. The  $a_{3l}$  minimum is 0.200 for case-hardened bearings and 0.126 for through-hardened bearings.**

A lubricant contamination factor is not included in the lubrication factor because Timken endurance tests are typically run with a 0.040 mm (0.00157 in.) filter to provide a realistic level of lubricant cleanliness for most applications.

### Geometry Factor ( $C_g$ )

$C_g$  is given for most tapered roller bearing part numbers in the appendix. The geometry factor also includes the material effects and load zone considerations. It should be noted that the primary effect of the load zone is on rolling element load distributions and contact stresses within the bearing, which are not quantified within the lubrication factor. Refer to the previous section, Load Zone Life Factor ( $a_{3k}$ ), for more information.

### LOAD FACTOR ( $C_I$ )

The  $C_I$  factor is obtained from the following figure. Note that the factor is different based on the type of bearing utilized.  $P_r$  is the equivalent load applied to the bearing in Newtons and is determined in the Equivalent Bearing Loads ( $P_r$ ) section.

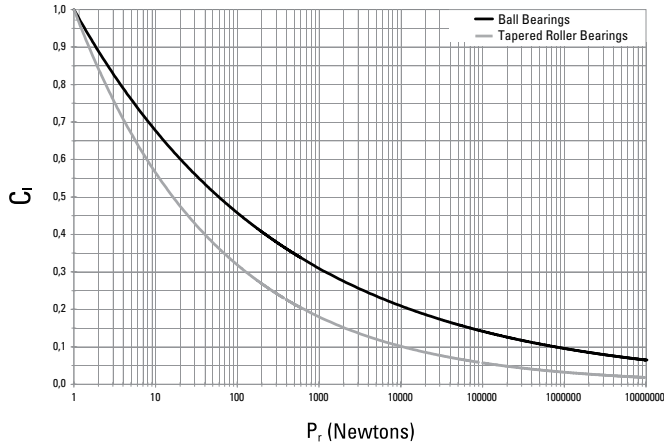

Fig. 47. Load factor ( $C_I$ ) vs. equivalent bearing load ( $P_r$ ).

### LOAD ZONE FACTOR ( $C_j$ )

As mentioned previously, for all non-tapered roller bearings the load zone factor is one <sup>(1)</sup>. For tapered roller bearings, the load zone factor can be taken from the graph based on the axial load applied to that bearing.

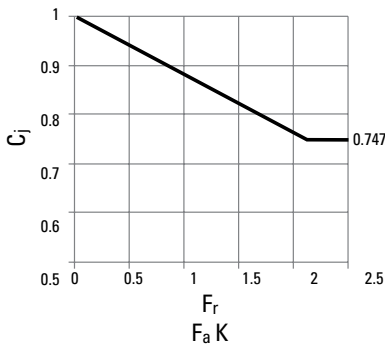

Fig. 48. Load factor ( $C_j$ ) vs. tapered bearing axial load ( $F_a$ ).

### SPEED FACTOR ( $C_s$ )

$C_s$  is determined from the following figure, where rev/min (RPM) is the rotational speed of the inner ring relative to the outer ring.

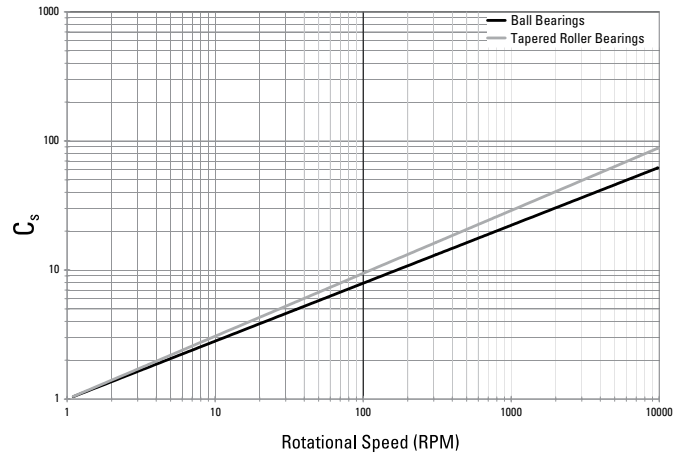

Fig. 49. Speed factor ( $C_s$ ) vs. rotational speed.

### VISCOSITY FACTOR ( $C_v$ )

The lubricant kinematic viscosity (centistokes [cSt]) is taken at the operating temperature of the bearing. The operating viscosity can be estimated by Fig. 50. The viscosity factor ( $C_v$ ) can then be determined from Fig. 51 on the following page.

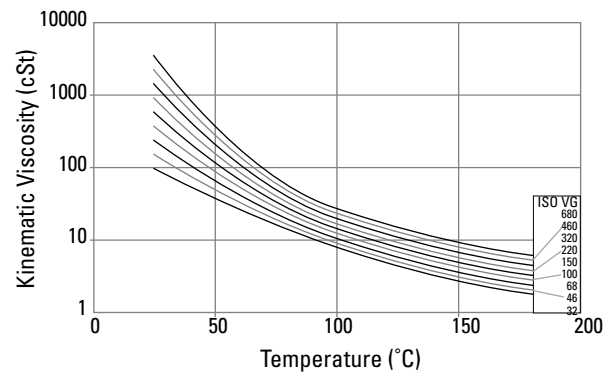

Fig. 50. Temperature vs. kinematic viscosity.

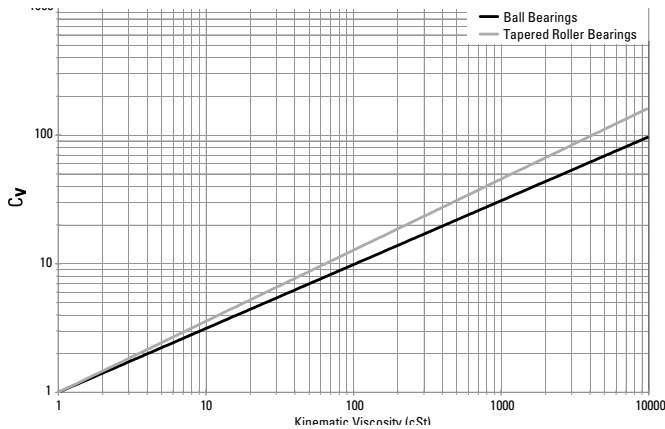

Fig. 51. Viscosity factor ( $C_v$ ) vs. kinematic viscosity.

### GREASE LUBRICATION FACTOR ( $C_{gr}$ )

For grease lubrication, the EHL lubrication film becomes depleted of oil over time and is reduced in thickness. Consequently, a reduction factor ( $C_{gr}$ ) should be used to adjust for this effect.

$$C_{gr} = 0.79$$

### MISALIGNMENT LIFE FACTOR ( $a_{3ma}$ )

The life of the bearing depends on the magnitude of the angle of misalignment, on the internal bearing geometry, and on the applied loads.

Accurate alignment of the shaft relative to the housing is critical for best performance. The life prediction using the method defined in this publication is relatively accurate up to the limits listed within, based on bearing type. The base condition, for which the load rating of the roller bearing is defined, is 0.0005 radians misalignment.

Performance of all Timken bearings under various levels of misalignment and radial and axial load can be predicted using sophisticated computer programs. Using these programs, Timken engineers can design special bearing-contact profiles to accommodate the conditions of radial load, axial load and/or bearing misalignment in your application. Consult your Timken representative for more information.

### LOW LOAD LIFE FACTOR ( $a_{3p}$ )

Bearing life tests at the Timken Technology Center have shown greatly extended bearing fatigue life performance is achievable when the bearing contact stresses are low and the lubricant film is sufficient to fully separate the micro-scale textures of the contacting surfaces. Mating the test data with sophisticated computer programs for predicting bearing performance, Timken engineers developed a low-load factor for use in the catalog to predict the life increase expected when operating under low-bearing loads. The following figure shows the low-load factor ( $a_{3p}$ ) as a function of the lubricant life factor ( $a_{3l}$ ) and the ratio of bearing dynamic rating to the bearing equivalent load.

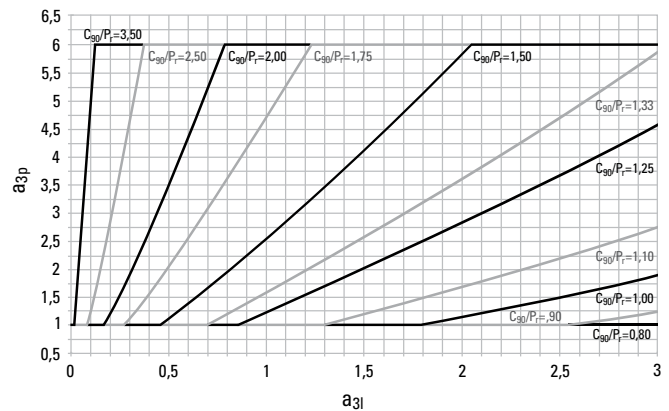

Fig. 52. Low load factor ( $a_{3p}$ ) vs. lubricant life factor ( $a_{3l}$ ) and  $C_{90}/P_r$  ratio.



## SYSTEM LIFE AND WEIGHTED AVERAGE LOAD AND LIFE SYSTEM LIFE

System reliability is the probability that all of the given bearings in a system will attain or exceed some required life. System reliability is the product of the individual bearing reliabilities in the system:

$$R_{(\text{system})} = R_A R_B R_C \dots R_n$$

In the application, the L<sub>10</sub> system life for a number of bearings each having different L<sub>10</sub> life is:

$$L_{10}(\text{system}) = [(1/L_{10A})^{3/2} + (1/L_{10B})^{3/2} + \dots (1/L_{10n})^{3/2}]^{-2/3}$$

## WEIGHTED AVERAGE LIFE AND LOAD EQUATIONS

In many applications, bearings are subjected to various conditions of loading and bearing selection is often made on the basis of maximum load and speed. However, under these conditions a more meaningful analysis may be made examining the loading cycle to determine the weighted average load.

Bearing selection based on weighted average loading will take into account variations in speed, load, and proportion of time during which the variable loads and speed occur. However, it is still necessary to consider extreme loading conditions to evaluate bearing contact stresses and alignment.

### Weighted Average Load

Variable speed, load and proportion time:

$$F_{wt} = [(n_1 T_1 F_1^{10/3} + \dots n_n T_n F_n^{10/3}) / n_a]^{0.3}$$

Where during each condition in a load cycle:

- T = proportion of total time
- F = load applied
- n = RPM
- n<sub>a</sub> = reference speed of rotation for use in bearing life equations. For convenience, 500 RPM is normally used by Timken.

Uniformly increasing load, constant speed:

$$F_w = [(3/13) (F_{max}^{13/3} - F_{min}^{13/3}) / (F_{max} - F_{min})]^{0.3}$$

Where, during a load cycle:

- F<sub>max</sub> = maximum applied load
- F<sub>min</sub> = minimum applied load

The above formulae does not allow the use of the life-modifying factor for lubrication a<sub>3l</sub>, except in the case of constant speed. Therefore, when these equations are used in the bearing selection process, the design L<sub>10</sub> bearing life should be based on a similar successful machine that operates in the same environment. Life calculations for both machines must be performing on the same basis. To allow for varying lubrication conditions in a load cycle, it is necessary to perform the weighted average life calculation.

### Weighted Average Life

$$L_{nwt} = 1 / \{ [T_1 / (L_n)_1] + [T_2 / (L_n)_2] + \dots [T_n / (L_n)_n] \}$$

Where, during a load cycle:

- T = proportion of total time
- L<sub>n</sub> = calculated rating life for each condition

## RATIOS OF BEARING LIFE TO LOADS, POWER AND SPEEDS

In applications subjected to variable conditions of loading, bearing life is calculated for one condition. Life for any other condition can easily be calculated by taking the ratio of certain variables. To use these ratios, the bearing load must vary proportionally with power, speed, or both. Nevertheless, this applies only to “catalog” lives or adjusted lives by any life adjustment factor(s). The following relationships hold under stated specific conditions:

**TABLE 13.**  
**LIFE RATIO EQUATIONS**

Condition	Equation
Variable load Variable speed	$(L_{10})_2 = (L_{10})_1 (P_1 / P_2)^{10/3} (n_1 / n_2)$
Variable power Variable speed	$(L_{10})_2 = (L_{10})_1 (H_1 / H_2)^{10/3} (n_2 / n_1)^{7/3}$
Constant load Variable speed	$(L_{10})_2 = (L_{10})_1 (n_1 / n_2)$
Constant power Variable speed	$(L_{10})_2 = (L_{10})_1 (n_2 / n_1)^{7/3}$
Variable load Constant speed	$(L_{10})_2 = (L_{10})_1 (P_1 / P_2)^{10/3}$
Variable power Constant speed	$(L_{10})_2 = (L_{10})_1 (H_1 / H_2)^{10/3}$

[P = Load, torque or tangential gear force]

To calculate system weighted life Timken determines the weighted life for each bearing separately and then calculates a system weighted life.

## PERMISSIBLE OPERATING SPEED AND LUBRICATION

When determining the permissible operating speeds corresponding to the bearing preloads used in machine tool spindles, many influencing factors are involved. Among those considered are spindle mass and construction, type of mounting, spindle rigidity and accuracy requirements, spindle loads, service life, type of service (intermittent or continuous), and method of lubrication.

*Bearing temperatures, generally, vary directly with both speed and load.* However, high-speed applications must have sufficient axial loading on the bearings to prevent heat generation due to rolling element skidding. The amount of bearing preload is determined primarily from these operating conditions. At lower speeds, the operating loads are heavier and the bearing deflections are greater. Therefore, the bearing preload must be high enough to provide adequate bearing rigidity under the heaviest loads and still maintain reasonable temperatures when the spindle is operated at high speeds.

## TAPERED ROLLER BEARINGS MEASURING RIB SPEED

The usual measure of the speed of a tapered roller bearing is the rib speed, which is the circumferential velocity at the midpoint of the inner ring large end rib (Fig. 53). This may be calculated as:

Rib speed:

$$V_r = \frac{\pi D_m n}{60000} \text{ (m/s)}$$

$$= \frac{\pi D_m n}{12} \text{ (ft/min)}$$

Where:

$D_m$  = mean inner ring large rib diameter      mm, in.  
 $n$  = bearing speed      rev/min

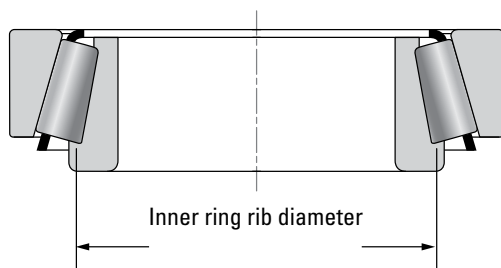

Fig. 53. Cone rib diameter. The inner ring rib diameter may be scaled from a print.

## EFFECT OF LUBRICATION ON SPEED CAPABILITY

The design of the tapered roller bearing results in a natural pumping effect on the lubricant, where the lubricant is forced from the small end of the roller end, heading toward the wider end. As speed increases, the lubricant begins to move outward due to centrifugal effects. At excessive speed, the contact between the roller large ends and the cone's rib face can become a concern. This is the primary reason for suggestions on the use of oil jets at this large end, ribbed-cup designs, or high-speed TSMA designs as operating speeds increase. Refer to the following speed guidelines for more details.

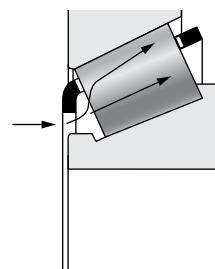

Fig. 54. Pumping effect of a tapered roller bearing.

There are no clear-cut speed limitations for tapered roller bearings since performance depends on the bearing design and lubrication system. The guidelines given in the table on page 39 are based on typical industrial experiences relating to speed and temperature for various types of lubrication systems, with bearings having low  $G_1$  factor.

Timken suggests that testing be performed for all new high-speed applications.

# SPEED GUIDELINES FOR TAPERED ROLLER BEARINGS IN MACHINE TOOL SPINDLES

**TABLE 14.**  
**SPEED GUIDELINES**

Bearing Type And Position	Cone Rib Speed (Feet/Minute)					
	0 - 2500	2500 - 4000	4000 - 6000	6000 - 8000	8000 - 10000	10000 - 20000
<b>TS bearing at nose position</b>						
With standard stamped cage	Yes	Yes	Yes	No	No	No
With thermal compensating device	N/R <sup>(10)</sup>	N/R	Consider <sup>(11)</sup>	Yes <sup>(11)</sup>	No	No
<b>With internal geometry modifications</b>						
With cage modifications	N/R	N/R	N/R	Yes	No	No
With silver-plated cage	N/R	N/R	N/R	Consider	No	No
With machined cage	N/R	N/R	N/R	N/R	No	No
With improved finish	N/R	N/R	N/R	Consider	No	No
<b>TSMA bearing at nose position</b>						
TSMA	N/R	N/R	N/R	Consider <sup>(11)</sup>	Yes <sup>(11)</sup>	Yes <sup>(11)</sup>
<b>With internal geometry modifications</b>						
With cage modifications	N/R	N/R	N/R	Yes	Yes	Yes
With silver-plated cage	N/R	N/R	N/R	Consider	Yes	Yes
With machined cage	N/R	N/R	N/R	N/R	Consider	Yes
With improved finish	N/R	N/R	N/R	Consider	Consider	Yes
<b>Ribbed cup bearing at nose position</b>						
Ribbed cup	N/R	N/R	N/R	N/R	Yes	Yes
<b>With internal geometry modifications</b>						
With silver-plated cage	N/R	N/R	N/R	N/R	Yes	Yes
With machined cage	N/R	N/R	N/R	N/R	Consider	Yes
With oil drainage holes in cup	N/R	N/R	N/R	N/R	Consider	Yes
With improved finish	N/R	N/R	N/R	N/R	Consider	Yes
<b>Hydra-Rib bearing at rear position</b>						
Standard Hydra-Rib	Consider	Consider	Consider	Yes	No	No
Modified Hydra-Rib	N/R	N/R	N/R	N/R	Yes	Yes
<b>With internal geometry modifications</b>						
With silver-plated cage	N/R	N/R	N/R	Consider	Yes	Yes
With machined cage	N/R	N/R	N/R	N/R	Consider	Yes
With oil drainage holes in cup	N/R	N/R	N/R	N/R	Consider	Yes
With improved finish	N/R	N/R	N/R	Consider	Consider	Yes
<b>Lubrication system</b>						
Standard spindle grease	Yes	No	No	No	No	No
Special high-speed grease	N/R	Yes <sup>(2)</sup>	No	No	No	No
Oil level	Yes <sup>(4)</sup>	Yes <sup>(4)</sup>	No	No	No	No
Air/oil or mist	N/R	Consider	Yes <sup>(1)</sup>	Yes <sup>(1)(6)</sup>	No	No
Circulating oil	N/R	N/R	Yes <sup>(5)</sup>	Yes <sup>(5)</sup>	Yes <sup>(6)</sup>	Yes <sup>(6)</sup>
Oil jets required under cage	N/R	N/R	N/R	Yes <sup>(7)</sup>	Yes <sup>(7)</sup>	Yes <sup>(7)</sup>
Oil jets required to backface rib	N/R	N/R	N/R	Yes <sup>(4)(7)</sup>	Yes <sup>(3)(7)</sup>	Yes <sup>(3)(7)</sup>

**TAPERED ROLLER BEARING DESIGNS**

2TS mounting (standard design)  
 2TS + TDO at rear (box mounting)<sup>(9)</sup>  
 2TS mounting w/spring mounting  
 TS mounting + Hydra-Rib  
 2 TSMA mounting front and rear  
 TSMA mounting + Hydra-Rib  
 2TS ribbed cup mounting  
 Ribbed cup mounting + Hydra-Rib

**SPINDLE BEARING DESIGN FACTORS**

K-Factor of 1.00 to 1.80 preferred.

Look at G<sub>1</sub> Factor for indication of heat generation characteristics.

Thin section L and LL type bearings should be given primary consideration.

Consult with your Timken representative to ensure bearings selected have good high-speed characteristics.

<sup>(1)</sup>Requires use of Hydra-Rib, Spring-Rib, or spring loaded design at rear position.

<sup>(2)</sup>Kluber NBU15, Mobil 28, or equivalent.

<sup>(3)</sup>Only for TSMA bearings.

<sup>(4)</sup>Use ISO VG32 or equivalent for oil level.

<sup>(5)</sup>Do not use greater than ISO VG32 or equivalent for circulating oil. Preferred is ISO VG22 or equivalent.

<sup>(6)</sup>Same as (9) except water jackets in housing would also be required.

<sup>(7)</sup>3 Jets at 120 degrees.

<sup>(8)</sup>Not to be used with TSMA design.

<sup>(9)</sup>Normally used for operating speeds less than 12.7 m/s (2500 fpm).

<sup>(10)</sup>Not required (N/R).

**LUBRICATION GUIDELINES FOR HIGHER SPEED BEARINGS**

A precision tapered roller bearing can meet almost any level of speed required by the machine tool industry with the TSMA and Hydra-Rib high-speed bearing designs, providing circulating oil lubrication can be accommodated.

Both the lubricant and lubrication system have an effect on heat-generation and heat-dissipation rates and thus are important to the speed capabilities of a bearing.

The choice of lubrication will depend on:

- Maximum speed requirement
- Heat dissipation rate of the system
- Spindle layout
- Orientation of the spindle

**INTERNAL BEARING DESIGN – G<sub>1</sub> FACTOR**

Internal bearing geometry has a direct influence on torque and, therefore heat generation. In order to rate the torque/heat generation characteristics of its bearings and to assist designers in selecting appropriate bearings, Timken developed a factor called G<sub>1</sub>: the lower the G<sub>1</sub> factor, the lower the heat generation. The G<sub>1</sub> factors are published in Timken catalogs and are listed in the appendix of this catalog for the precision tapered roller bearing part numbers listed in the tapered roller bearing section.

This G<sub>1</sub> factor is of prime importance to a designer because of the influence of operating temperature on spindle accuracy.

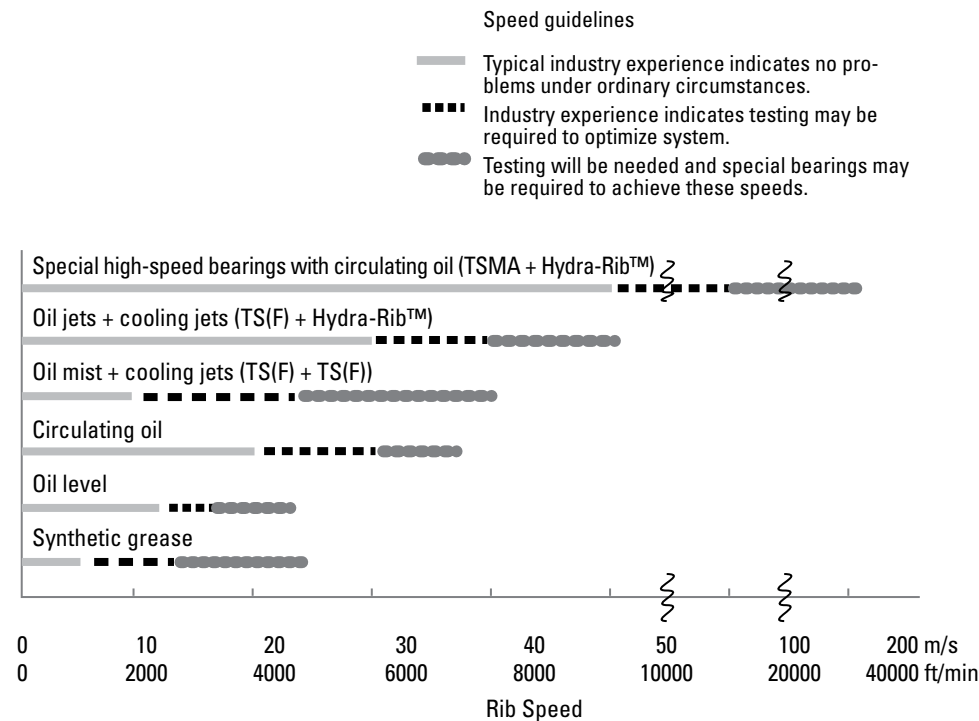

**Fig. 55. Speed capability guidelines for various types of lubrication systems.**

## LUBRICATION TAPERED ROLLER BEARINGS

The selection of the lubricant and lubricant delivery method is directly linked with the speedability of a bearing. It is strongly suggested that the section on permissible operating speed be reviewed by the customer in addition to this section on lubrication.

### GREASE

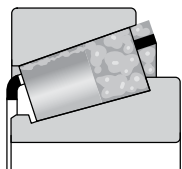

Fig. 56. Filling a bearing with synthetic grease.

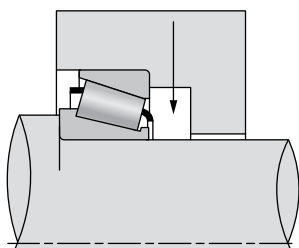

Fig. 57. Simple radial oil inlet hole with oil collector.

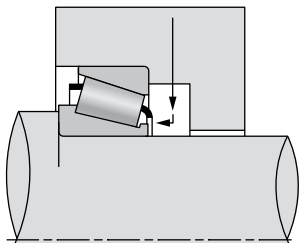

Fig. 58. Axial oil jet to direct oil at small end of the rollers.

Grease lubrication speed limits are lower than limits for oil lubrication because all the heat must be carried away by conduction through the shaft and housing.

### Mineral Grease

When conventional (mineral) greases are used, the rib speed should be limited to 5 m/s (985 fpm). This limit can be increased under pure radial loads up to 13 m/s (2560 fpm) provided that the bearings remain in end play under all operating conditions. Generally, No. 2 consistency greases are used with medium- to low-viscosity base oils.

Lubricant quantity ( $V_{mg}$ ) may be approximated by using the following equation:

$$V_{mg} = f_{mg} \times V = f_{mg} \times \left[ \frac{\pi}{4} \times T \times (D^2 - d^2) \times 10^{-3} - \frac{M}{7.8 \times 10^{-3}} \right] \text{ (cm}^3\text{)}$$

Where:

$f_{mg}$	= factor depending on speed: $0.3 < f_{mg} < 0.5$	
$V$	= free volume of the bearing	( $\text{cm}^3$ )
$T$	= overall bearing width	(mm)
$D$	= cup outer diameter	(mm)
$d$	= cone bore	(mm)
$M$	= bearing weight	(kg)
$\pi$	= 3.1416	

### Synthetic Grease

The use of "low-torque" greases (or synthetic greases) can be considered for rib speeds over 13 m/s (2560 fpm), up to maximum of 25 m/s (4920 fpm). Experience has shown that stabilized temperatures, around 15° C to 20° C (27° F to 36° F) above ambient, can be obtained at the maximum permissible speed.

It is important to follow these procedures to help achieve the above performance:

- All corrosion protection is removed from the bearing surfaces by using an organic solvent.
- Very small initial quantity of grease is applied to prevent excessive churning.
- Initial run-in period to evacuate unnecessary grease from the bearing.
- Good spindle design to retain grease around the bearings.
- Efficient sealing to protect against external contamination.

Lubricant quantity ( $V_{sg}$ ) may be approximated by using the following equation:

$$V_{sg} = f_{sg} \times V = f_{sg} \times \left[ \frac{\pi}{4} \times T \times (D^2 - d^2) \times 10^{-3} - \frac{M}{7.8 \times 10^{-3}} \right] \text{ (cm}^3\text{)}$$

Where:

$f_{sg}$	= factor depending on speed: $0.15 < f_{sg} < 0.3$
$\pi$	= 3.1416

When using synthetic greases, the limiting factor is the "lubrication for life" concept (without re-greasing). Depending on load and speed conditions, the grease life will typically be limited to 5000 to 8000 hours.

The Timken Company's suggestions for the use and run-in of synthetic greases are illustrated later in this section.

A normal way to fill the bearing with grease is to do it by hand before heating and fitting the components. For the cone, the free volume corresponding to the first third of the rollers, starting from their large end, is filled with grease; an additional quantity is provided below the cage. For the cup, a thin film of grease is spread all around the race as shown in Fig. 56 on the previous page.

## OIL

Grease lubrication of spindle bearings is generally preferred by machine tool builders over oil circulation lubrication due to its simplicity and low heat generation. For high loads or high speeds, however, circulating oil is probably the most widely used method because of its capability to remove heat from the spindle.

## Oil Circulation

Many parameters have to be considered in designing an efficient oil circulation lubrication system:

- Oil characteristics.
- Oil flow rates.
- Oil feed and drain systems.
- Heat dissipation rate of the bearing system.

The latter is affected by factors such as conduction through the housing walls and convection by the circulating lubricant.

## Oil Characteristics

A low-viscosity mineral oil in the range of ISO VG10 to ISO VG22 is generally specified for the bearings. This choice will minimize heat generation, particularly at high speeds, where the lowest practical viscosity is required. Care must be taken, however, if gears are used for the power transmission because the choice of the common lubricant will be systematically dictated by the needs of the gears. High-quality mineral oils having suitable additives for lubricating both the gears and bearings are available with a relatively low viscosity.

## Oil Feed System

Forced-feed oil systems are generally used in the machine tool industry. In a typical system, oil is pumped from a central reservoir to each bearing separately. Oil is introduced at the small end of the rollers and drained away at the large end to take advantage of the natural pumping action of tapered roller bearings.

Circulating oil allows a continuous regulated oil flow. Apart from providing the advantages of maximum heat dissipation, it also has the added benefit of removing any contamination or debris that could possibly cause bearing wear.

Heat exchangers can be included in a circulating system to reduce oil inlet temperature and better regulate the running temperature of the system. Filters of 0.040 mm (0.00157 in.) size also are generally provided to remove debris.

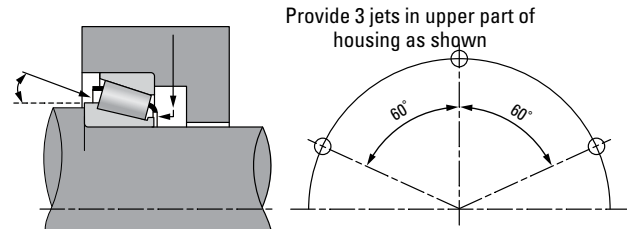

**Fig. 59. Cooling jets in top part of the housing for speed above 25 m/s (4920 fpm).**

Experience has shown that for speeds up to 20 m/s (3940 fpm), a simple radial oil inlet hole in the top part of the housing in conjunction with an oil collector is sufficient (Fig. 57 on the previous page). For speeds over 20 m/s (3940 fpm), an axial oil jet should be positioned to direct oil at the small end of the roller at the gap between the cage and the inner ring (Fig. 58 on the previous page). For high speeds or in case of large size bearings, additional oil jets can be arranged about the circumference to better distribute the oil within the bearings.



With increasing speeds (approximately 25 m/s [4920 fpm] and above), the effect of centrifugal force will throw the oil to the outside along the cup race. To prevent lubricant starvation at the inner ring rib, and consequent bearing burnup, additional oil jets have to be provided in the top part of the housing (Fig. 59 on the previous page).

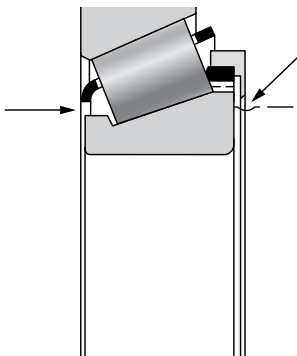

Fig. 60. The TSMA bearing.

For rib speeds over 40 m/s (7874 fpm), special high-speed TSMA bearings have been developed. A special provision for lubrication of the roller-rib contact area is provided to ensure adequate lubrication. The concept works by capturing oil in a manifold attached to the inner ring and directing it to the roller-rib contact area through holes drilled axially in the inner ring (Fig. 60).

### Oil Drainage System

An effective circulating oil system requires adequate drainage to prevent an oil buildup that would cause excessive churning and unnecessary heat generation. Oil passing through a high-speed bearing will exit the bearing at a high velocity and also will swirl around the housing in the direction of rotation of the bearing. To effectively drain the oil away, the high velocity must be slowed and the swirling action stopped so that the oil will fall down into the drain area. A drain catch basin is required to break up the flow of oil and direct the oil to the drain hole (Fig. 61). Oil drain sections must be adequately dimensioned to ease the rapid evacuation of the oil.

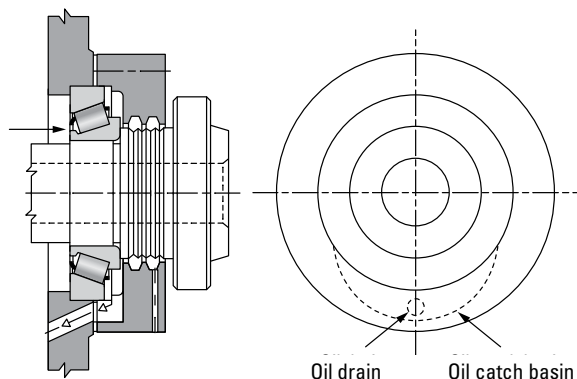

Fig. 61. Oil drain design.

### BALL BEARINGS

Even though ball bearings have the least amount of friction of any of the common rolling bearings, lubrication is required to minimize rolling resistance due to deformation of the balls in the raceways under load, and to minimize any sliding friction that occurs between the balls, the raceway and the cage. Lubrication also serves to protect the accurately ground and polished surfaces from corrosion. In addition, lubrication in general dissipates generated heat and can help protect the bearing from the entry of foreign matter.

Regardless of the method of lubrication or type of lubricant, it is important that quality lubricants be used to minimize oxidation, gumming or sludging and that the lubricant be clean and free of moisture to minimize wear.

Only enough lubrication to accomplish these purposes should be used since another source of heat may become present, namely friction between the lubricant and the moving parts, in the form of churning or internal shear of the lubricant itself.

In the lubrication of ball bearings it is important to realize that a small quantity of oil or grease will, if constantly present in the bearing, suffice for its requirements. It should be noted that trouble can result from too much lubrication just as it can from too little. Both conditions should be avoided. Excessive oil or grease will result in high temperature and possible damage. When grease is used, it is necessary to take into consideration the maximum operating temperature. Particular attention must be given to the housing design relating to the proximity of the grease to the bearing, to assure adequate purge room and grease retention.

Depending upon operating speeds, loads and temperatures, machine tool ball bearings are lubricated with grease, oil or oil mist. In general, oils are required when bearings operate at high speeds as they provide greater cooling than is possible with grease.

The following relationship may be used to estimate the effect of preload and lubrication method on the Permissible Operating Speed (SP).

$$SP = F_L \times F_P \times F_B \times N_G$$

Where:

$F_L$  = lubrication factor

$F_P$  = preload factor

$F_B$  = ball material factor

$N_G$  is Permissible Speed for a single, grease-lubricated bearing with inner ring rotation. This value is found with the part number tables.

Factors are as follows:

**TABLE 15.**  
**LUBRICATION FACTOR = ( $F_L$ )**

Lubrication Factor ( $F_L$ )	
Grease	$F_L = 1.00$
Oil bath	$F_L = 1.50$
Oil mist	$F_L = 1.70$
Oil jet or metered oil	$F_L = 2.00$

**TABLE 16.**  
**BEARING PRELOAD FACTOR = ( $F_P$ )**

Bearing Mounting Arrangement	Bearing Preload		
	L	M	H
	0,85	0,70	0,50
	0,80	0,60	0,40
	0,65	0,50	0,30
	0,65	0,50	0,30
	0,70	0,60	0,35
	0,60	0,40	0,20
	0,65	0,45	0,25

**TABLE 17.**  
**BALL MATERIAL FACTOR ( $F_B$ )**

Ball Material Factor ( $F_B$ )	
Steel balls	$F_B = 1.00$
Ceramic balls <sup>(1)</sup>	$F_B = 1.20$

<sup>(1)</sup>Ceramic balls allow 20 percent increase to speed factor.

## GREASE

The use of grease as a lubricant for Timken super precision ball bearings on various spindle applications is becoming more popular, due to the development of better ball bearing greases, simplification of design and elimination of the “human maintenance factor,” which is frequently responsible for too much lubrication, not enough lubrication, or the wrong kind of lubrication. Prelubricating the bearings at assembly with the correct amount of the correct grease, thus eliminating all grease fittings, has increased bearing life in many instances.

For successful lubrication, grease for ball bearings should have good mechanical and chemical stability with low-torque characteristics. Two different types of grease, one soft and the other firmer, have proved to be suitable lubricants for machine tool spindle bearings. The “soft” greases have a worked penetration factor corresponding to NLGI of two or less. The firmer grease has a worked penetration factor of three or more and is of the channeling type. All greases show a very slight change in consistency after operation in a bearing. As the softer grease has a tendency to churn, particular attention should be given to the quantity packed into the bearing. Because the firmer grease is of the channeling type, the amount used is not as critical.

For super precision ball bearings below a 500000 dN value, which is equivalent to a 50.000 mm (1.9685 in.) bore bearing rotating at 10000 RPM, either a light-consistency grease or the channeling grease may be used.

At continuous speeds above a dN value of 500000, the operating temperature is generally lower when the bearings are lubricated with a lower-consistency grease and after sufficient break-in.

However, the grease quantity in each bearing must be limited. At these higher speeds, an excessive amount of grease in the bearing may result in greatly increased operating temperatures due to churning action. This condition, if uncontrolled, may lead to premature bearing damage.

## Grease and Speed Capability

Before selecting a grease, it is important to define a relative speed capability of the application. There is no precise method that can be applied to determine the operating speed of a bearing. Over the years, designers of machine tool systems have been guided by their own experiences from which many basic "rules of thumb" have been established. One such rule is the dN speed value.

$$dN = \text{Bore in millimeters} \times \text{RPM}$$

The most common spindle greases that Timken suggests for Timken spindle ball bearings are:

<b>Unirex N3</b>	Vertical applications < 500000 dN
<b>Mobil 28</b>	Light loads < 600000 dN
<b>Chevron SRI</b>	Medium to heavy loads < 350000 dN
<b>Kluber Isoflex NBU 15/ NCA 15</b>	Light loads, vertical or horizontal applications > 500000 dN
<b>Kluber BF-7222</b>	Light loads, vertical or horizontal applications at higher speeds > 750000 dN

## OIL

Although several grease products have been successful at dN values as high as one million, oils are generally suggested for bearings operating at high speeds or to provide more cooling and dissipation of heat than is possible with grease. High-grade spindle oil having a viscosity of 100 seconds Saybolt at 37° C (100° F) is suggested for use in drip-feed oilers, oil bath lubrication arrangements and oil mist systems. In heavily loaded applications, oil in relatively large quantities must be supplied, and where temperatures run higher than normal, oil coolers will be suggested. Churning of a large pool of oil is to be avoided if speed is significant.

### Oil Bath

The conventional oil-bath system for lubricating the bearings is satisfactory for low and moderate speeds. The static oil level must never be higher than the center of the lowermost ball. When the shaft is rotating, the running level may drop considerably below the standstill level, depending on the speed of the revolving parts. A sight gauge or other suitable method should be provided to permit an easy check.

### Drip-Feed Oil

Where the speeds are considered high for oil bath and the bearings are moderately loaded, oil introduced through a filter-type, sight-feed oiler is suggested. This assures a constant supply of lubricant. The feed in drops-per-minute is determined by closely observing the operating temperatures.

### Oil Jet

In applications where the ball bearing is heavily loaded and operating at high speed and high temperatures, or where the operating conditions are severe with high ambient temperatures, oil jet lubrication may be required. In such cases, it is necessary to lubricate each bearing location individually and to provide adequately large drain openings to prevent excessive accumulation of oil after it has passed through the bearings.<sup>(1)</sup>

### Oil Mist

Oil mist lubrication is often used for spindles running continuously at high speeds. With this method of lubrication, oil of the proper viscosity is atomized into finely divided particles, mixed with clean, filtered, dry compressed air and directed to pass through the bearings in a constant stream. This oil is metered into the air under pressure. This system not only lubricates the bearings, it affords some cooling due to the air flow. This continuous passage of air and oil through the bearings and the labyrinth seals also serves to prevent the entrance of contaminants into the bearings.

To ensure the “wetting” of the bearings and to prevent possible damage to the balls and raceways, it is imperative that the oil mist system be turned on for several minutes before the spindle is started. The importance of wetting the bearings before starting cannot be overstated and has particular significance for spindles that have been idle for extended periods of time. To avoid such effects, most oil mist systems have interlocks that make it impossible to start the spindle until the lubricating system is working properly and the bearings are thoroughly wetted.<sup>(1)</sup>

### Metered Air/Oil

This method is similar to the oil mist; however, the oil is fed by periodic pulses to the lubrication line providing a higher air-to-oil ratio. Therefore, this method lowers the operating bearing temperature and lubricant shear effects, enabling higher operating speeds.<sup>(1)</sup>

<sup>(1)</sup>For further information, refer to the lubrication specification tables found on pages 240-241.

**TABLE 18.  
LUBRICATION SYSTEM COMPARISON**

Lubrication Type	System Cost	Typical Speed (dN) <sup>(2)</sup>
Grease	Low	500000
High-speed grease	Low	750000
Oil bath	Low	400000
Oil drip	Low	600000
Oil mist	Medium	1000000
Metered air/oil	High	>1000000
Oil jet	High	>1000000

<sup>(2)</sup>Speed value is an approximation and assumes proper mounting and preload techniques along with average loading conditions. For more specific guidance contact your Timken representative.

The speed, “dN,” value is obtained by multiplying the bearing bore size in millimeters by the shaft RPM.



## RUN-IN PROCEDURES TAPERED ROLLER BEARINGS WITH SYNTHETIC GREASE

The aim of run-in cycles is to correctly spread the grease inside the bearing, to avoid churning of the grease and excessive bearing temperature.

During run-in operations, the bearing temperature must be constantly monitored and immediately plotted on a graph so that any tendency of the curve toward a vertical asymptote can be averted. Temperature probes, placed closest to the bearings, will provide better control of the run-in operations.

The other advantage of the graph is to help determine the run-in time at a given speed. When the curve becomes horizontal, it shows that the temperature has stabilized. It is then possible to proceed to the next speed.

The indicated times may vary depending on the speeds and heat dissipation capacity of the spindles.

According to the results obtained on the prototype, it may be possible to reduce either the number or the length (or both) of the run-in steps for production spindles. In any event, temperature control should be retained for safety reasons.

When running-in multi-speed spindles, reduced speeds must be chosen at start-up of the cycles. The speed can be progressively increased until the bearings evacuate any excessive quantities of grease.

**TABLE 19.**  
**RUN-IN SUGGESTIONS FOR SYNTHETIC GREASE-LUBRICATED  
TAPERED ROLLER BEARINGS WITH SINGLE-SPEED SPINDLES**

Time		Action
10	sec	Run
1	min	Stop
20	sec	Run
1	min	Stop
30	sec	Run
1	min	Stop
40	sec	Run
1	min	Stop
50	sec	Run
1	min	Stop
1	min	Run
1	min	Stop
90	sec	Run
1	min	Stop
2	min	Run
1	min	Stop
3	min	Run*
1	min	Stop
4	min	Run*
1	min	Stop
6	min	Run*
1	min	Stop
10	min	Run*
20	min	Stop

⇒ Then run until temperature stabilizes. At this step of the cycle, as well as at the other steps marked \*, closely watch the curve's shape. If it tends to be vertical, stop 15 minutes and run again at 75 percent of max. speed until the temperature stabilizes again. Then restart the cycle from the beginning at max. speed.

**TABLE 20.**  
**RUN-IN SUGGESTIONS FOR SYNTHETIC GREASE-LUBRICATED TAPERED ROLLER BEARINGS WITH MULTI-SPEED SPINDLES**

25% Max. Speed		50% Max. Speed		75% Max Speed		Max. Speed	
Time	Action	Time	Action	Time	Action	Time	Action
1 min	Run	1 min	Run	1 min	Run	1 min	Run
1 min	Stop	1 min	Stop	1 min	Stop	1 min	Stop
1 min	Run	1 min	Run	1 min	Run	1 min	Run
1 min	Stop	1 min	Stop	1 min	Stop	1 min	Stop
2 min	Run	2 min	Run	2 min	Run	2 min	Run
1 min	Stop	1 min	Stop	1 min	Stop	1 min	Stop
3 min	Run	3 min	Run	3 min	Run	3 min	Run
5 min	Stop	5 min	Stop	5 min	Stop	5 min	Stop
⇒ Then run until temperature stabilizes.		⇒ Then run until temperature stabilizes.		⇒ Then run and closely watch the curve's shape during running, until stabilization. If it tends to be vertical, stop 15 minutes and run again at same speed.		⇒ Then run until temperature stabilizes. At this step of the cycle, closely watch the curve's shape. If it tends to be vertical, stop 15 minutes and run again at 75 percent of max. speed until the temperature stabilizes again. Then restart the cycle from the beginning at max. speed.	

## BALL BEARINGS WITH GREASE LUBRICATION

Fig. 62 shows bearing temperature increase due to run-in procedure. The peaking temperature followed by the leveling off is a result of the new grease being worked and then stabilized for a particular condition of load and speed.

It is important that the peak temperature not exceed 55° C (100° F) above room temperature since the chemical consistency and characteristics of the grease can be permanently altered. Thus, the proper run-in procedure is to run the machine until the spindle temperature rises to 65° C (150° F) and then turn it off to allow the grease to cool. Repeat until the spindle temperature stabilizes at a temperature below 54° C (130° F).

Fig. 63 shows the typical temperature rise of the bearing once the grease has been worked in for the specific speed and load.

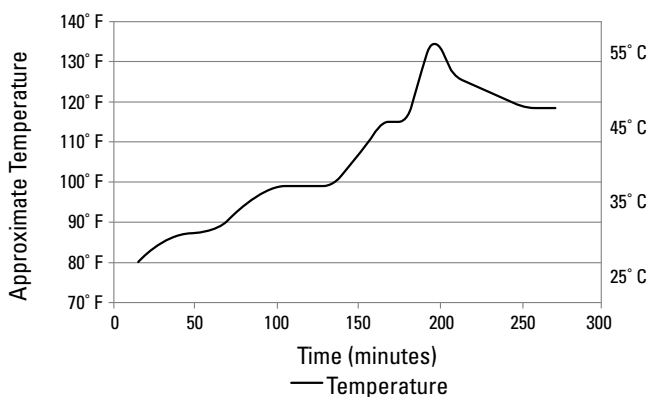

**Fig. 62. Typical temperature profile during break-in (4 speed increments from 200000 dN start to 800000 dN finish).**

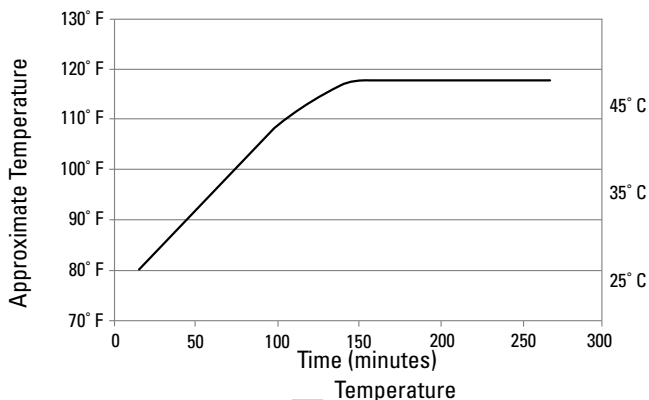

**Fig. 63. Typical temperature after break-in procedure.**

## BALL BEARINGS WITH GREASE (FOR SPEEDS > 500000 dN)

A proper run-in procedure will provide the following results:

- Expel the excess grease from the bearings.
- Orient the lubricating film on each contact surface.
- Establish a low-equilibrium operating temperature.

### RUN-IN PROCEDURE

1. Install proper quantity of grease.
2. Start at a reasonable low speed, typically 10 percent of the maximum operating speed.
3. Increase speed with small, reasonable increments when a stable temperature is reached.
4. Continue incremental increase in speed as described. If a rapid temperature increase occurs (temperature exceeds 70° C [158° F]), stop the run-in process.

*Maximum bearing temperatures should not exceed 70° C (158° F). Temperatures in excess of 70° C (158° F) may cause excessive bearing preloads and possible permanent grease or bearing damage.*

5. Allow the system to cool to room temperature.
6. Restart procedure at the last speed prior to the temperature spike.
7. Continue repeating the above cycle until an equilibrium temperature is reached at the maximum operating speed of the application. *The ideal equilibrium operating temperature is 35° C to 46° C (95° F to 115° F).*

### ALTERNATIVE RUN-IN PROCEDURE (WHEN UNABLE TO CONTROL INCREMENTAL SPEEDS)

Run-in at constant speed also is possible. In this operation, the bearing should run at full speed for about 30 seconds. After stopping, the heat in the bearing dissipates. In this way, a dangerous temperature rise is prevented. The non-running time depends on the various design factors, but it should be at least five times greater than the running time. This process is repeated until the bearing temperature becomes constant.



## VERTICAL SPINDLES

For vertical axis spindles, special attention must be paid to the lubrication and sealing. Modified sealing is required to prevent the coolant from contaminating the lubricant when the spindle nose bearing is at the upper position (Fig. 64).

In the case of grease lubrication, deflectors have to be installed to prevent grease migration away from the bearing cavity. Alternatively, when oil lubrication is adopted and the nose bearing is at the lower position, a system to collect and extract the oil has to be provided to prevent leakage (Fig. 65).

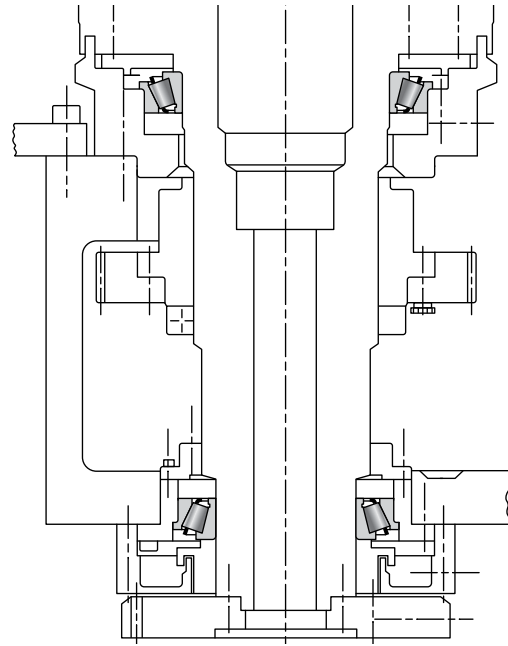

Fig. 64. Vertical axis spindle.

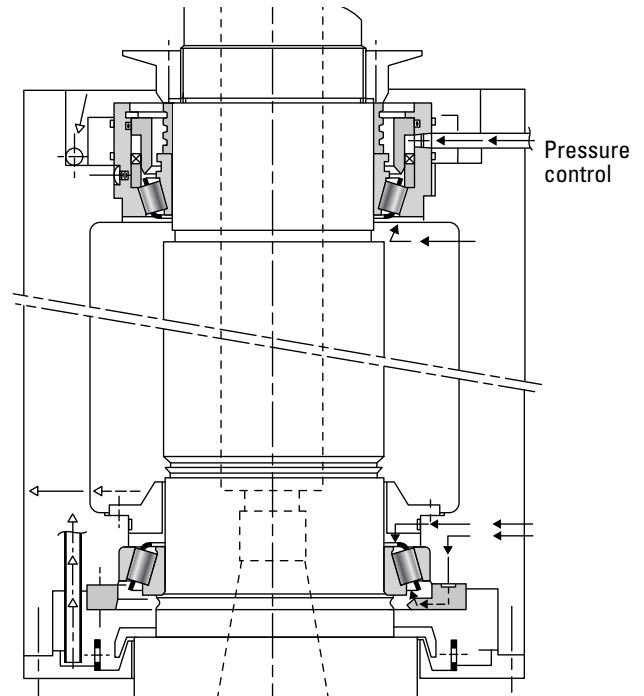

Fig. 65. Typical example of proper use of an oil-lubricated vertical axis spindle with pressure control for the oil and a means to collect and extract the oil.

# HEAT GENERATION AND DISSIPATION TAPERED ROLLER BEARINGS

## HEAT GENERATION

Under normal operating conditions, most of the torque and heat generated by the bearing is due to the elastohydrodynamic losses at the contact area between rollers and races.

The following equation is used to calculate the heat generated by the bearing:

$$Q_{gen} = k_4 n M$$

$$M = k_1 G_1 (n\mu)^{0.62} (P_{eq})^{0.3}$$

Where:

- $Q_{gen}$  = generated heat (W or Btu/min)
- $M$  = running torque N.m or lbf-in.
- $n$  = rotational speed (RPM)
- $G_1$  = geometry factor from bearing data tables
- $\mu$  = viscosity at operating temperature (cP)
- $P_{eq}$  = dynamic equivalent load (N or lbf)
- $k_1$  = bearing torque constant  
=  $2.56 \times 10^{-6}$  for  $M$  in N-m  
=  $3.54 \times 10^{-5}$  for  $M$  in lbf-in.
- $k_4$  = dimensional factor to calculate heat generation rate  
= 0.105 for  $Q_{gen}$  in W when  $M$  in N-m  
=  $6.73 \times 10^{-4}$  for  $Q_{gen}$  in Btu/min when  $M$  in lbf-in.

The generated heat will be underestimated if operating speed:

$$n \leq \frac{k_2}{G_2 \times \mu} \left( \frac{f_2 \times F_r}{K} \right)^{0.66} \text{ RPM}$$

Where:

- $G_2$  = geometry factor (from bearing data tables)
- $k_2$  = 625 (metric) or 1700 (in.)
- $K$  = K factor of the bearing (from bearing data tables)
- $f_2$  = combined load factor (Fig. 66)

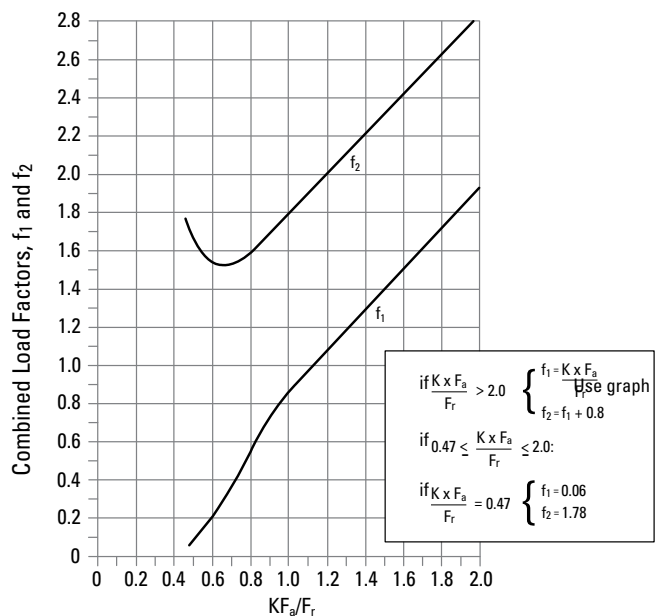

Fig. 66. Determination of combined load factors  $f_1$  and  $f_2$ .

TABLE 21.  
DETERMINATION OF DYNAMIC EQUIVALENT LOAD  $P_{eq}$

Design (Thrust $F_{ae}$ Onto A)	Thrust Condition	Net Axial Load	Dynamic Equivalent Load $P_{eq}$
	$\frac{0.47 \times F_{rA}}{K_A} \leq \frac{0.47 \times F_{rB}}{K_B} + F_{ae}$	$F_{aA} = \frac{0.47 \times F_{rB}}{K_B} + F_{ae}$ $F_{aB} = \frac{0.47 \times F_{rB}}{K_B}$	$P_{eq} = \left( \frac{f_1 \times F_r}{K} \right)$ <p><math>f_1</math> = combined load factor (see Fig. 66)</p>
	$\frac{0.47 \times F_{rA}}{K_A} > \frac{0.47 \times F_{rB}}{K_B} + F_{ae}$	$F_{aA} = \frac{0.47 \times F_{rA}}{K_A}$ $F_{aB} = \frac{0.47 \times F_{rA}}{K_A} - F_{ae}$	

## HEAT DISSIPATION

The heat dissipation rate of a bearing system is affected by many factors, and the modes of heat transfer need to be considered. Major heat transfer modes in most systems are conduction through the housing walls, convection at the inside and outside surfaces of the housing, and convection by the circulating lubricant. In many applications, overall heat dissipation can be divided into two categories:

- Heat removed by circulating oil.
- Heat removed through the housing.

### Heat Dissipation by Circulating Oil

Heat dissipated by a circulating oil system is:

$$Q_{oil} = k_5 \times f \times (\theta_o - \theta_i)$$

If a circulating lubricant other than petroleum oil is used, the heat carried away by that lubricant will be:

$$Q_{oil} = k_6 \times C_p \times \rho \times f \times (\theta_o - \theta_i)$$

Where:

$k_5$  = dimensional factor to calculate heat carried away by a petroleum oil

$k_5 = 28$  for  $Q_{oil}$  in W when  $f$  in L/min and  $\theta$  in °C

$k_5 = 0.42$  for  $Q_{oil}$  in Btu/min when  $f$  in U.S. pt/min and  $\theta$  in °F

$k_6$  = dimensional factor to calculate heat carried away by a circulating fluid

$k_6 = 1.67 \times 10^{-5}$  for  $Q_{oil}$  in W

$k_6 = 1.67 \times 10^{-2}$  for  $Q_{oil}$  in Btu/min

$Q_{oil}$  = heat dissipation rate of circulating oil W, Btu/min

$\theta_i$  = oil inlet temperature °C, °F

$\theta_o$  = oil outlet temperature °C, °F

$C_p$  = specific heat of lubricant J/(kg x °C), Btu/(lb x °F)

$f$  = lubricant flow rate L/min, U.S. pt/min

$\rho$  = lubricant density kg/m<sup>3</sup>, lb/ft<sup>3</sup>

If lubricant flow is unrestricted on the outlet side of a bearing, the flow rate that can freely pass through the bearing depends on bearing size and internal geometry, direction of oil flow, bearing speed and lubricant properties.

A tapered roller bearing has a natural tendency to pump oil from the small end to the large end of the rollers. For maximum oil flow and heat dissipation, the oil inlet should be adjacent to the small end of the rollers.

In a splash or oil level lubrication system, heat will be carried by convection to the inner walls of the housing. The heat dissipation rate with this lubrication method can be enhanced by using cooling coils in the housing sump.

### Heat Dissipation Through Housing

Heat removed through the housing is, in most cases, difficult to determine analytically. If the steady-state bearing temperature is known for one operating condition, the following method can be used to estimate the housing heat dissipation rate.

At the steady-state temperature, the total heat dissipation rate from the bearing must equal the heat generation rate of the bearing. The difference between the heat generation rate and heat dissipation rate of the oil is the heat dissipation rate of the housing at the known temperature.

Heat losses from housings are primarily by conduction and convection and are therefore nearly linearly related to temperature difference. Thus, the housing heat dissipation rate is:

$$Q_{hsg} = C (\theta_o - \theta_{ambt})$$

At the operating condition where the steady-state temperature is known, the housing heat dissipation factor can be estimated as:

$$C = \frac{Q_{gen} - Q_{oil}}{\theta_o - \theta_{ambt}}$$

## BALL BEARINGS

### HEAT GENERATION

Low operating temperatures, combined with adequate spindle rigidity, are important and highly desirable for precision machine tools. This is particularly true for high-speed grinding spindles where the preload of the bearings is the principal load imposed upon them. Some of the benefits derived from low operating temperatures are better dimensional stability of the processed work, less need for bearing lubrication, prevention of objectionable heat at the external surfaces of the spindle housing, and elimination of troubles due to thermal effects on mounting fits and preloads.

### PRELOAD AND HEAT GENERATION

The heat developed at the bearings under load is a function of the operating speed and the bearing preload. Preloading is necessary for maximum axial and radial rigidity. Unfortunately, if speeds are increased, the bearing preload may have to be lessened to maintain proper operating temperatures at the bearing.

For high-speed operation, the bearing preload should be sufficient to maintain proper rolling friction for the balls, but not so high as to generate excessive heat. In cases where lower operating speeds are desired, bearing preloads may be increased to obtain additional bearing rigidity, provided the proper operating temperatures are maintained. Thus, a balance between heat generation and spindle rigidity dictates the amount of bearing preload that is used, commensurate with the operational speed and the bearing life required.

How bearing preload affects the operating temperature is illustrated in Fig. 67. This graph applies to 207-size, angular contact, duplexed super precision ball bearings, mounted back-to-back. Curve A is a plot of operating temperature at the bearing outside diameter for the speeds indicated, using bearings with a high built-in preload. Curve B is for bearings having a low preload. The slope of Curve A is much steeper than that of Curve B. Using bearings with a high preload, the temperature rise at the bearing outside diameter is 34° C (93° F) when operating at 3600 RPM. For the same temperature rise using bearings with low preload, an operating speed of 15300 RPM is indicated. Therefore, it is evident that for higher-speed operation, the bearing preload should be kept to the minimum necessary to ensure sufficient bearing rigidity.

For workhead spindles, the operating speeds are generally low and the loading conditions heavy. Maximum radial and axial spindle rigidity is required under these loads, making increased bearing

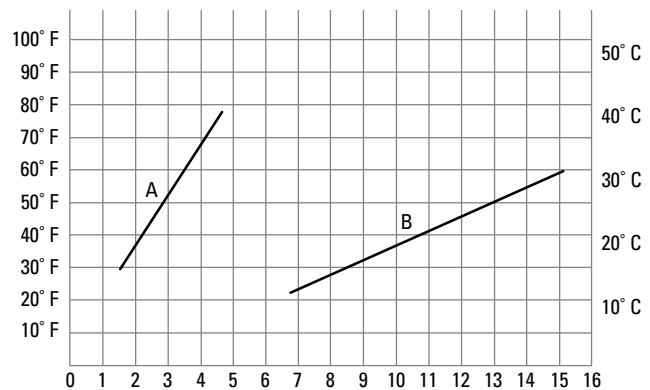

Fig. 67. Effect of preload on temperature rise.

preload mandatory.

### BEARING GEOMETRY AND HEAT GENERATION

It should be noted that a bearing's internal geometry has a major impact on heat generation. High-speed designs, such as the Timken HX Series, incorporate "optimized" internal geometries that balance load-carrying capacity, stiffness and heat generation.

### HEAT DISSIPATION

When ball bearing spindles are grease lubricated, the heat generated is removed only by conduction through the surrounding parts. With jet or circulating oil lubrication, generated heat is dissipated by the oil passing through the bearings as well as by conduction through the shaft and housing. Both means of removing heat from the bearings are important, but generally, dissipation through conduction is less obvious.

As an example, in an oil mist-lubricated grinding spindle, the nose or wheel-end bearings are fixed and close to the grinding coolant. The pulley-end or rear bearings are secured axially on the shaft, but permitted to float laterally in the housing to compensate for size variations due to thermal changes. Heat is conducted away from the front bearings at a faster rate because of the thermal mass of the spindle nose and the intimate contact of the outer rings with the housing shoulder, the end cover and the housing bore. This condition, coupled with oil mist lubrication and the proximity of the grinding coolant, takes away generated heat efficiently.

The rear or floating pair of bearings is not so favored. Usually, the thermal mass of the shaft at the drive-end is not so great. The drive-end possesses some heat-conduction ability, but also receives heat generated by belt friction. The absence of grinding coolant and the reduced area of conduction usually results in a slightly higher operating temperature.

# TOLERANCES

## TAPERED ROLLER BEARINGS

Tapered roller bearings are manufactured to a number of specifications or “classes” that define tolerances on dimensions such as bore, O.D., width and runout. The Timken Company produces bearings in both inch and metric systems. The boundary dimension tolerances applicable to these two categories of bearings differ.

**TABLE 22.**  
**TAPERED ROLLER BEARING PRECISION CLASSES**

Tapered Roller Bearings - Precision Class				
Timken Metric	C	B	A	AA
Timken Inch	3	0	00	000
ISO/DIN	P5	P4	P2	-
ABMA Metric	C	B	A	-
ABMA Inch	3	0	00	-

Crossed Tapered - Precision Class		
Timken Metric	S	P
Timken Inch	3	0

**TABLE 23.**  
**METRIC BEARING TOLERANCES - CONE BORE**

Bearing Types <sup>(1)</sup>	Cone Bore		Precision Bearing Class							
	Bore		C		B		A		AA	
	Over	Incl.	Max.	Min.	Max.	Min.	Max.	Min.	Max.	Min.
TS TSF	<b>10.000</b>	<b>18.000</b>	<b>0.000</b>	<b>-0.007</b>	<b>0.000</b>	<b>-0.005</b>	<b>0.000</b>	<b>-0.005</b>	<b>0.000</b>	<b>-0.005</b>
	0.3937	0.7087	0.0000	-0.0003	0.0000	-0.0002	0.0000	-0.0002	0.0000	-0.0002
	<b>18.000</b>	<b>30.000</b>	<b>0.000</b>	<b>-0.008</b>	<b>0.000</b>	<b>-0.006</b>	<b>0.000</b>	<b>-0.006</b>	<b>0.000</b>	<b>-0.006</b>
	0.7087	1.1811	0.0000	-0.0003	0.0000	-0.0002	0.0000	-0.0002	0.0000	-0.0002
	<b>30.000</b>	<b>50.000</b>	<b>0.000</b>	<b>-0.010</b>	<b>0.000</b>	<b>-0.008</b>	<b>0.000</b>	<b>-0.008</b>	<b>0.000</b>	<b>-0.008</b>
	1.1811	1.9685	0.0000	-0.0004	0.0000	-0.0003	0.0000	-0.0003	0.0000	-0.0003
	<b>50.000</b>	<b>80.000</b>	<b>0.000</b>	<b>-0.012</b>	<b>0.000</b>	<b>-0.009</b>	<b>0.000</b>	<b>-0.008</b>	<b>0.000</b>	<b>-0.008</b>
	1.9685	3.1496	0.0000	-0.0005	0.0000	-0.0004	0.0000	-0.0003	0.0000	-0.0003
	<b>80.000</b>	<b>120.000</b>	<b>0.000</b>	<b>-0.015</b>	<b>0.000</b>	<b>-0.010</b>	<b>0.000</b>	<b>-0.008</b>	<b>0.000</b>	<b>-0.008</b>
	3.1496	4.7244	0.0000	-0.0006	0.0000	-0.0004	0.0000	-0.0003	0.0000	-0.0003
	<b>120.000</b>	<b>180.000</b>	<b>0.000</b>	<b>-0.018</b>	<b>0.000</b>	<b>-0.013</b>	<b>0.000</b>	<b>-0.008</b>	<b>0.000</b>	<b>-0.008</b>
	4.7244	7.0866	0.0000	-0.0007	0.0000	-0.0005	0.0000	-0.0003	0.0000	-0.0003
	<b>180.000</b>	<b>250.000</b>	<b>0.000</b>	<b>-0.022</b>	<b>0.000</b>	<b>-0.015</b>	<b>0.000</b>	<b>-0.008</b>	<b>0.000</b>	<b>-0.008</b>
	7.0866	9.8425	0.0000	-0.0009	0.0000	-0.0006	0.0000	-0.0003	0.0000	-0.0003
	<b>250.000</b>	<b>265.000</b>	<b>0.000</b>	<b>-0.022</b>	<b>0.000</b>	<b>-0.015</b>	<b>0.000</b>	<b>-0.008</b>	<b>0.000</b>	<b>-0.008</b>
	9.8425	10.4331	0.0000	-0.0009	0.0000	-0.0006	0.0000	-0.0003	0.0000	-0.0003
	<b>265.000</b>	<b>315.000</b>	<b>0.000</b>	<b>-0.022</b>	<b>0.000</b>	<b>-0.015</b>	<b>0.000</b>	<b>-0.008</b>	<b>0.000</b>	<b>-0.008</b>
	10.4331	12.4016	0.0000	-0.0009	0.0000	-0.0006	0.0000	-0.0003	0.0000	-0.0003
	<b>315.000</b>	<b>400.000</b>	<b>0.000</b>	<b>-0.025</b>	-	-	-	-	-	-
	12.4016	15.7480	0.0000	-0.0010	-	-	-	-	-	-
<b>400.000</b>	<b>500.000</b>	<b>0.000</b>	<b>-0.025</b>	-	-	-	-	-	-	
15.7480	19.6850	0.0000	-0.0010	-	-	-	-	-	-	
<b>500.000</b>	<b>630.000</b>	<b>0.000</b>	<b>-0.030</b>	-	-	-	-	-	-	
19.6850	24.8031	0.0000	-0.0012	-	-	-	-	-	-	
<b>630.000</b>	<b>800.000</b>	<b>0.000</b>	<b>-0.040</b>	-	-	-	-	-	-	
24.8031	31.4961	0.0000	-0.0016	-	-	-	-	-	-	
<b>800.000</b>	<b>1000.000</b>	<b>0.000</b>	<b>-0.050</b>	-	-	-	-	-	-	
31.4961	39.3701	0.0000	-0.0020	-	-	-	-	-	-	
<b>1000.000</b>	<b>1200.000</b>	<b>0.000</b>	<b>-0.060</b>	-	-	-	-	-	-	
39.3701	47.2441	0.0000	-0.0024	-	-	-	-	-	-	
<b>1200.000</b>	<b>1600.000</b>	<b>0.000</b>	<b>-0.080</b>	-	-	-	-	-	-	
47.2441	62.9921	0.0000	-0.0031	-	-	-	-	-	-	

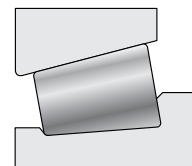

The major difference between the two tolerance systems is that inch bearings have historically been manufactured to positive bore and O.D. tolerances, whereas metric bearings have been manufactured to negative tolerances.

## METRIC SYSTEM BEARINGS (ISO AND “J” PREFIX PARTS)

Timken manufactures metric system bearings to four tolerance classes. Classes C, B, A and AA are “precision” classes. These tolerances lie within those currently specified in ISO 492 with the exception of a small number of dimensions indicated in the tables. The differences normally have an insignificant effect on the mounting and performance of tapered roller bearings. The adjacent table illustrates the current ISO bearing class that corresponds approximately to each of The Timken Company metric bearing classes.

<sup>(1)</sup>Not all types and sizes are listed in this catalog. Contact your Timken representative for further information.

TABLE 24.  
METRIC BEARING TOLERANCES - CUP O.D.

Bearing Types <sup>(1)</sup>	Cup O.D.		Precision Bearing Class							
	Over	Incl.	C		B		A		AA	
			Max.	Min.	Max.	Min.	Max.	Min.	Max.	Min.
	mm in.	mm in.	mm in.	mm in.	mm in.	mm in.	mm in.	mm in.	mm in.	mm in.
TS TSF	10.000	18.000	—	—	—	—	0.000	-0.008	0.000	-0.008
	0.3937	0.7087	—	—	—	—	0.0000	-0.0003	0.0000	-0.0003
	18.000	30.000	0.000	-0.008	0.000	-0.006	0.000	-0.008	0.000	-0.008
	0.7087	1.1811	0.0000	-0.0003	0.0000	-0.0002	0.0000	-0.0003	0.0000	-0.0003
	30.000	50.000	0.000	-0.009	0.000	-0.007	0.000	-0.008	0.000	-0.008
	1.1811	1.9685	0.0000	-0.0004	0.0000	-0.0003	0.0000	-0.0003	0.0000	-0.0003
	50.000	80.000	0.000	-0.011	0.000	-0.009	0.000	-0.008	0.000	-0.008
	1.9685	3.1496	0.0000	-0.0004	0.0000	-0.0004	0.0000	-0.0003	0.0000	-0.0003
	80.000	120.000	0.000	-0.013	0.000	-0.010	0.000	-0.008	0.000	-0.008
	3.1496	4.7244	0.0000	-0.0005	0.0000	-0.0004	0.0000	-0.0003	0.0000	-0.0003
	120.000	150.000	0.000	-0.015	0.000	-0.011	0.000	-0.008	0.000	-0.008
	4.7244	5.9055	0.0000	-0.0006	0.0000	-0.0004	0.0000	-0.0003	0.0000	-0.0003
	150.000	180.000	0.000	-0.018	0.000	-0.013	0.000	-0.008	0.000	-0.008
	5.9055	7.0866	0.0000	-0.0007	0.0000	-0.0005	0.0000	-0.0003	0.0000	-0.0003
	180.000	250.000	0.000	-0.020	0.000	-0.015	0.000	-0.008	0.000	-0.008
	7.0866	9.8425	0.0000	-0.0008	0.0000	-0.0006	0.0000	-0.0003	0.0000	-0.0003
	250.000	265.000	0.000	-0.025	0.000	-0.018	0.000	-0.008	0.000	-0.008
	9.8425	10.4331	0.0000	-0.0010	0.0000	-0.0007	0.0000	-0.0003	0.0000	-0.0003
	265.000	315.000	0.000	-0.025	0.000	-0.018	0.000	-0.008	0.000	-0.008
	10.4331	12.4016	0.0000	-0.0010	0.0000	-0.0007	0.0000	-0.0003	0.0000	-0.0003
	315.000	400.000	0.000	-0.028	0.000	-0.020	—	—	—	—
	12.4016	15.7480	0.0000	-0.0011	0.0000	-0.0008	—	—	—	—
	400.000	500.000	0.000	-0.030	—	—	—	—	—	—
	15.7480	19.6850	0.0000	-0.0012	—	—	—	—	—	—
500.000	630.000	0.000	-0.035	—	—	—	—	—	—	
19.6850	24.8031	0.0000	-0.0014	—	—	—	—	—	—	
630.000	800.000	0.000	-0.040	—	—	—	—	—	—	
24.8031	31.4961	0.0000	-0.0016	—	—	—	—	—	—	
800.000	1000.000	0.000	-0.050	—	—	—	—	—	—	
31.4961	39.3701	0.0000	-0.0020	—	—	—	—	—	—	
1000.000	1200.000	0.000	-0.060	—	—	—	—	—	—	
39.3701	47.2441	0.0000	-0.0024	—	—	—	—	—	—	
1200.000	1600.000	0.000	-0.080	—	—	—	—	—	—	
47.2441	62.9921	0.0000	-0.0031	—	—	—	—	—	—	

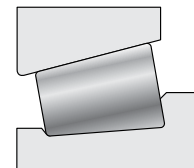
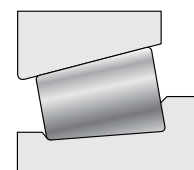

TABLE 25.  
METRIC BEARING TOLERANCES - CONE WIDTH

Bearing Types <sup>(1)</sup>	Cone Width		Precision Bearing Class							
	Over	Incl.	C		B		A		AA	
			Max.	Min.	Max.	Min.	Max.	Min.	Max.	Min.
	mm in.	mm in.	mm in.	mm in.	mm in.	mm in.	mm in.	mm in.	mm in.	mm in.
TS TSF	10.000	50.000	0.000	-0.200	0.000	-0.200	0.000	-0.200	0.000	-0.200
	0.3937	1.9685	0.0000	-0.0079	0.0000	-0.0079	0.0000	-0.0079	0.0000	-0.0079
	50.000	120.000	0.000	-0.300	0.000	-0.300	0.000	-0.300	0.000	-0.300
	1.9685	4.7244	0.0000	-0.0118	0.0000	-0.0118	0.0000	-0.0118	0.0000	-0.0118
	120.000	180.000	0.000	-0.300	0.000	-0.300	0.000	-0.300	0.000	-0.300
	4.7244	7.0866	0.0000	-0.0118	0.0000	-0.0118	0.0000	-0.0118	0.0000	-0.0118
	180.000	250.000	0.000	-0.350	0.000	-0.350	0.000	-0.350	0.000	-0.350
	7.0866	9.8425	0.0000	-0.0138	0.0000	-0.0138	0.0000	-0.0138	0.0000	-0.0138
	250.000	265.000	0.000	-0.350	0.000	-0.350	0.000	-0.350	0.000	-0.350
	9.8425	10.4331	0.0000	-0.0138	0.0000	-0.0138	0.0000	-0.0138	0.0000	-0.0138
	265.000	315.000	0.000	-0.350	0.000	-0.350	0.000	-0.350	0.000	-0.350
	10.4331	12.4016	0.0000	-0.0138	0.0000	-0.0138	0.0000	-0.0138	0.0000	-0.0138
	315.000	500.000	0.000	-0.350	—	—	—	—	—	—
	12.4016	19.6850	0.0000	-0.0138	—	—	—	—	—	—
	500.000	630.000	0.000	-0.350	—	—	—	—	—	—
	19.6850	24.8031	0.0000	-0.0138	—	—	—	—	—	—
	630.000	1200.000	0.000	-0.350	—	—	—	—	—	—
	24.8031	47.2441	0.0000	-0.0138	—	—	—	—	—	—
	1200.000	1600.000	0.000	-0.350	—	—	—	—	—	—
	47.2441	62.9921	0.0000	-0.0138	—	—	—	—	—	—



<sup>(1)</sup>Not all types and sizes are listed in this catalog. Contact your Timken representative for further information.



**TABLE 26.**  
**METRIC BEARING TOLERANCES - CUP WIDTH**

Bearing Types <sup>(1)</sup>	Cup Width		Precision Bearing Class							
	Cup O.D. Over	Incl.	C		B		A		AA	
			Max.	Min.	Max.	Min.	Max.	Min.	Max.	Min.
TS TSF	<b>10.000</b>	<b>80.000</b>	<b>0.000</b>	<b>-0.150</b>	<b>0.000</b>	<b>-0.150</b>	<b>0.000</b>	<b>-0.150</b>	<b>0.000</b>	<b>-0.150</b>
	0.3937	3.1496	0.0000	-0.0059	0.0000	-0.0059	0.0000	-0.0059	0.0000	-0.0059
	<b>80.000</b>	<b>150.000</b>	<b>0.000</b>	<b>-0.200</b>	<b>0.000</b>	<b>-0.200</b>	<b>0.000</b>	<b>-0.200</b>	<b>0.000</b>	<b>-0.200</b>
	3.1496	5.9055	0.0000	-0.0079	0.0000	-0.0079	0.0000	-0.0079	0.0000	-0.0079
	<b>150.000</b>	<b>180.000</b>	<b>0.000</b>	<b>-0.250</b>	<b>0.000</b>	<b>-0.250</b>	<b>0.000</b>	<b>-0.250</b>	<b>0.000</b>	<b>-0.250</b>
	5.9055	7.0866	0.0000	-0.0098	0.0000	-0.0098	0.0000	-0.0098	0.0000	-0.0098
	<b>180.000</b>	<b>250.000</b>	<b>0.000</b>	<b>-0.250</b>	<b>0.000</b>	<b>-0.250</b>	<b>0.000</b>	<b>-0.250</b>	<b>0.000</b>	<b>-0.250</b>
	7.0866	9.8425	0.0000	-0.0098	0.0000	-0.0098	0.0000	-0.0098	0.0000	-0.0098
	<b>250.000</b>	<b>265.000</b>	<b>0.000</b>	<b>-0.300</b>	<b>0.000</b>	<b>-0.300</b>	<b>0.000</b>	<b>-0.300</b>	<b>0.000</b>	<b>-0.300</b>
	9.8425	10.4331	0.0000	-0.0118	0.0000	-0.0118	0.0000	-0.0118	0.0000	-0.0118
	<b>265.000</b>	<b>315.000</b>	<b>0.000</b>	<b>-0.300</b>	<b>0.000</b>	<b>-0.300</b>	<b>0.000</b>	<b>-0.300</b>	<b>0.000</b>	<b>-0.300</b>
	10.4331	12.4016	0.0000	-0.0118	0.0000	-0.0118	0.0000	-0.0118	0.0000	-0.0118
	<b>315.000</b>	<b>400.000</b>	<b>0.000</b>	<b>-0.300</b>	<b>0.000</b>	<b>-0.300</b>	-	-	-	-
	12.4016	15.7480	0.0000	-0.0118	0.0000	-0.0118	-	-	-	-
<b>400.000</b>	<b>500.000</b>	<b>0.000</b>	<b>-0.350</b>	-	-	-	-	-	-	
15.7480	19.6850	0.0000	-0.0138	-	-	-	-	-	-	
<b>500.000</b>	<b>800.000</b>	<b>0.000</b>	<b>-0.350</b>	-	-	-	-	-	-	
19.6850	31.4961	0.0000	-0.0138	-	-	-	-	-	-	
<b>800.000</b>	<b>1200.000</b>	<b>0.000</b>	<b>-0.400</b>	-	-	-	-	-	-	
31.4961	47.2441	0.0000	-0.0157	-	-	-	-	-	-	
<b>1200.000</b>	<b>1600.000</b>	<b>0.000</b>	<b>-0.400</b>	-	-	-	-	-	-	
47.2441	62.9921	0.0000	-0.0157	-	-	-	-	-	-	

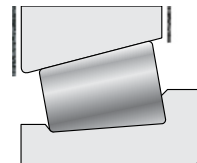

**TABLE 27.**  
**METRIC BEARING TOLERANCES - CONE STAND**

Bearing Types <sup>(1)</sup>	Cone Stand		Precision Bearing Class							
	Bore Over	Incl.	C		B		A		AA	
			Max.	Min.	Max.	Min.	Max.	Min.	Max.	Min.
TS TSF	<b>10.000</b>	<b>80.000</b>	<b>+0.100</b>	<b>-0.100</b>						
	0.3937	3.1496	+0.0039	-0.0039						
	<b>80.000</b>	<b>120.000</b>	<b>+0.100</b>	<b>-0.100</b>						
	3.1496	4.7244	+0.0039	-0.0039						
	<b>120.000</b>	<b>180.000</b>	<b>+0.100</b>	<b>-0.100</b>	(2)	(2)	(2)	(2)	(2)	(2)
	4.7244	7.0866	+0.0039	-0.0039						
	<b>180.000</b>	<b>250.000</b>	<b>+0.100</b>	<b>-0.150</b>						
	7.0866	9.8425	+0.0039	-0.0059						
	<b>250.000</b>	<b>265.000</b>	<b>+0.100</b>	<b>-0.150</b>						
	9.8425	10.4331	+0.0039	-0.0059						
<b>265.000</b>	<b>315.000</b>	<b>+0.100</b>	<b>-0.150</b>							
10.4331	12.4016	+0.0039	-0.0059							
<b>315.000</b>	<b>400.000</b>	<b>+0.150</b>	<b>-0.150</b>	-	-	-	-	-	-	
12.4016	15.7480	+0.0059	-0.0059	-	-	-	-	-	-	
<b>400.000</b>	-	(2)	(2)	-	-	-	-	-	-	
15.7480	-			-	-	-	-	-	-	

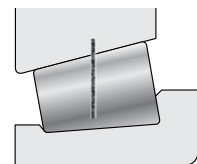

Cone Stand. Cone stand is a measure of the variation in cone raceway size, taper and roller diameter. This is checked by measuring the axial location of the reference surface of a master cup or other type gage with respect to the reference cone face.

<sup>(1)</sup>Not all types and sizes are listed in this catalog. Contact your Timken representative for further information.

<sup>(2)</sup>These sizes manufactured as matched assemblies only.

**TABLE 28.**  
**METRIC BEARING TOLERANCES - CUP STAND**

Bearing Types <sup>(1)</sup>	Cup Stand		Precision Bearing Class							
	Over	Incl.	C		B		A		AA	
			Max.	Min.	Max.	Min.	Max.	Min.	Max.	Min.
	mm in.	mm in.	mm in.	mm in.	mm in.	mm in.	mm in.	mm in.	mm in.	mm in.
TS TSF <sup>(3)</sup>	<b>10.000</b>	<b>18.000</b>	<b>+0.100</b>	<b>-0.100</b>						
	0.3937	0.7087	+0.0039	-0.0039						
	<b>18.000</b>	<b>80.000</b>	<b>+0.100</b>	<b>-0.100</b>						
	0.7087	3.1496	+0.0039	-0.0039						
	<b>80.000</b>	<b>120.000</b>	<b>+0.100</b>	<b>-0.100</b>	(2)	(2)	(2)	(2)	(2)	(2)
	3.1496	4.7244	+0.0039	-0.0039						
	<b>120.000</b>	<b>265.000</b>	<b>+0.100</b>	<b>-0.150</b>						
	4.7244	10.4331	+0.0039	-0.0059						
<b>265.000</b>	<b>315.000</b>	<b>+0.100</b>	<b>-0.150</b>							
10.4331	12.4016	+0.0039	-0.0059							
<b>315.000</b>	<b>400.000</b>	<b>+0.100</b>	<b>-0.150</b>	-	-	-	-	-	-	
12.4016	15.7480	+0.0039	-0.0059	-	-	-	-	-	-	
<b>400.000</b>	-		(2)	(2)	-	-	-	-	-	
15.7480	-				-	-	-	-	-	

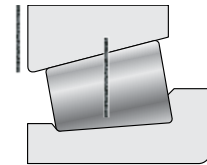

Cup Stand. Cup stand is a measure of the variation in cup I.D. size and taper. This is checked by measuring the axial location of the reference surface of a master plug or other type gage with respect to the reference face of the cup.

<sup>(1)</sup>Not all types and sizes are listed in this catalog. Contact your Timken representative for further information.

<sup>(2)</sup>These sizes manufactured as matched assemblies only.

<sup>(3)</sup>Stand for flanged cup is measured from flange backface (seating face).

**TABLE 29.**  
**METRIC BEARING TOLERANCES - OVERALL BEARING WIDTH**

Bearing Types <sup>(1)</sup>	Overall Bearing Width		Precision Bearing Class							
	Over	Incl.	C		B		A		AA	
			Max.	Min.	Max.	Min.	Max.	Min.	Max.	Min.
	mm in.	mm in.	mm in.	mm in.	mm in.	mm in.	mm in.	mm in.	mm in.	mm in.
TS TSF <sup>(2)</sup>	<b>10.000</b>	<b>80.000</b>	<b>+0.200</b>	<b>-0.200</b>	<b>+0.200</b>	<b>-0.200</b>	<b>+0.200</b>	<b>-0.200</b>	<b>+0.200</b>	<b>-0.200</b>
	0.3937	3.1496	+0.0079	-0.0079	+0.0079	-0.0079	+0.0079	-0.0079	+0.0079	-0.0079
	<b>80.000</b>	<b>120.000</b>	<b>+0.200</b>	<b>-0.200</b>	<b>+0.200</b>	<b>-0.200</b>	<b>+0.200</b>	<b>-0.200</b>	<b>+0.200</b>	<b>-0.200</b>
	3.1496	4.7244	+0.0079	-0.0079	+0.0079	-0.0079	+0.0079	-0.0079	+0.0079	-0.0079
	<b>120.000</b>	<b>180.000</b>	<b>+0.350</b>	<b>-0.250</b>	<b>+0.200</b>	<b>-0.250</b>	<b>+0.200</b>	<b>-0.250</b>	<b>+0.200</b>	<b>-0.250</b>
	4.7244	7.0866	+0.0138	-0.0098	+0.0079	-0.0098	+0.0079	-0.0098	+0.0079	-0.0098
	<b>180.000</b>	<b>250.000</b>	<b>+0.350</b>	<b>-0.250</b>	<b>+0.200</b>	<b>-0.300</b>	<b>+0.200</b>	<b>-0.300</b>	<b>+0.200</b>	<b>-0.300</b>
	7.0866	9.8425	+0.0138	-0.0098	+0.0079	-0.0118	+0.0079	-0.0118	+0.0079	-0.0118
	<b>250.000</b>	<b>265.000</b>	<b>+0.350</b>	<b>-0.300</b>	<b>+0.200</b>	<b>-0.300</b>	<b>+0.200</b>	<b>-0.300</b>	<b>+0.200</b>	<b>-0.300</b>
	9.8425	10.4331	+0.0138	-0.0118	+0.0079	-0.0118	+0.0079	-0.0118	+0.0079	-0.0118
	<b>265.000</b>	<b>315.000</b>	<b>+0.350</b>	<b>-0.300</b>	<b>+0.200</b>	<b>-0.300</b>	<b>+0.200</b>	<b>-0.300</b>	<b>+0.200</b>	<b>-0.300</b>
	10.4331	12.4016	+0.0138	-0.0118	+0.0079	-0.0118	+0.0079	-0.0118	+0.0079	-0.0118
	<b>315.000</b>	<b>500.000</b>	<b>+0.350</b>	<b>-0.300</b>	-	-	-	-	-	-
	12.4016	19.6850	+0.0138	-0.0118	-	-	-	-	-	-
	<b>500.000</b>	<b>800.000</b>	<b>+0.350</b>	<b>-0.400</b>	-	-	-	-	-	-
	19.6850	31.4961	+0.0138	-0.0157	-	-	-	-	-	-
	<b>800.000</b>	<b>1000.000</b>	<b>+0.350</b>	<b>-0.400</b>	-	-	-	-	-	-
	31.4961	39.3701	+0.0138	-0.0157	-	-	-	-	-	-
	<b>1000.000</b>	<b>1200.000</b>	<b>+0.350</b>	<b>-0.450</b>	-	-	-	-	-	-
	39.3701	47.2441	+0.0138	-0.0177	-	-	-	-	-	-
<b>1200.000</b>	<b>1600.000</b>	<b>+0.350</b>	<b>-0.500</b>	-	-	-	-	-	-	
47.2441	62.9921	+0.0138	-0.0197	-	-	-	-	-	-	

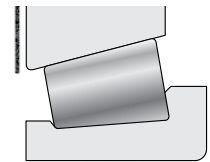

<sup>(1)</sup>Not all types and sizes are listed in this catalog. Contact your Timken representative for further information.

<sup>(2)</sup>For bearing type TSF, the tolerance applies to the dimension T<sub>1</sub>.

**TABLE 30.**  
**METRIC BEARING TOLERANCES - ASSEMBLED BEARING MAXIMUM RADIAL RUNOUT**

Bearing Types <sup>(1)</sup>	Assembled Bearing Maximum Radial Runout		Precision Bearing Class			
	Over Bore	Incl.	C	B	A	AA
	mm in.	mm in.	mm in.	mm in.	mm in.	mm in.
	<b>10.000</b> 0.3937	<b>18.000</b> 0.7087	<b>0.005</b> -	<b>0.003</b> 0.0001	<b>0.002</b> 0.00008	<b>0.001</b> 0.00004
	<b>18.000</b> 0.7087	<b>30.000</b> 1.1811	<b>0.005</b> 0.0002	<b>0.003</b> 0.0001	<b>0.002</b> 0.00008	<b>0.001</b> 0.00004
	<b>30.000</b> 1.1811	<b>50.000</b> 1.9685	<b>0.006</b> 0.0002	<b>0.003</b> 0.0001	<b>0.002</b> 0.00008	<b>0.001</b> 0.00004
	<b>50.000</b> 1.9685	<b>80.000</b> 3.1496	<b>0.006</b> 0.0002	<b>0.004</b> 0.0002	<b>0.002</b> 0.00008	<b>0.001</b> 0.00004
	<b>80.000</b> 3.1496	<b>120.000</b> 4.7244	<b>0.006</b> 0.0002	<b>0.004</b> 0.0002	<b>0.002</b> 0.00008	<b>0.001</b> 0.00004
	<b>120.000</b> 4.7244	<b>150.000</b> 5.9055	<b>0.007</b> 0.0003	<b>0.004</b> 0.0002	<b>0.002</b> 0.00008	<b>0.001</b> 0.00004
	<b>150.000</b> 5.9055	<b>180.000</b> 7.0866	<b>0.008</b> 0.0003	<b>0.004</b> 0.0002	<b>0.002</b> 0.00008	<b>0.001</b> 0.00004
	<b>180.000</b> 7.0866	<b>250.000</b> 9.8425	<b>0.010</b> 0.0004	<b>0.005</b> 0.0002	<b>0.002</b> 0.00008	<b>0.001</b> 0.00004
	<b>250.000</b> 9.8425	<b>265.000</b> 10.4331	<b>0.011</b> 0.0004	<b>0.005</b> 0.0002	<b>0.002</b> 0.00008	<b>0.001</b> 0.00004
	<b>265.000</b> 10.4331	<b>315.000</b> 12.4016	<b>0.011</b> 0.0004	<b>0.005</b> 0.0002	<b>0.002</b> 0.00008	<b>0.001</b> 0.00004
	<b>315.000</b> 12.4016	<b>400.000</b> 15.7480	<b>0.013</b> 0.0005	<b>0.005</b> 0.0002	-	-
	<b>400.000</b> 15.7480	<b>500.000</b> 19.6850	<b>0.018</b> 0.0007	-	-	-
	<b>500.000</b> 19.6850	<b>630.000</b> 24.8031	<b>0.025</b> 0.0010	-	-	-
	<b>630.000</b> 24.8031	<b>800.000</b> 31.4961	<b>0.035</b> 0.0014	-	-	-
	<b>800.000</b> 31.4961	<b>1000.000</b> 39.3701	<b>0.050</b> 0.0020	-	-	-
	<b>1000.000</b> 39.3701	<b>1200.000</b> 47.2441	<b>0.060</b> 0.0024	-	-	-
	<b>1200.000</b> 47.2441	<b>1600.000</b> 62.9921	<b>0.080</b> 0.0031	-	-	-

TS  
TSF

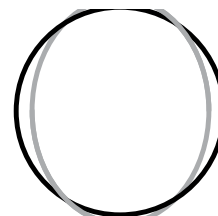

Runout. Runout is a measure of rotational accuracy expressed by Total Indicator Reading (T.I.R.). Total displacement is measured by an instrument sensing against a moving surface, or moved with respect to a fixed surface. A radial runout measurement includes both roundness errors and the centering error of the surface that the instrument head senses against.

<sup>(1)</sup>Not all types and sizes are listed in this catalog. Contact your Timken representative for further information.

**METRIC SYSTEM BEARINGS  
(TXR PREFIX PARTS)**

**TABLE 31.  
METRIC BEARING TOLERANCES - OUTER RACE O.D.**

Bearing Types	Outer Race O.D.		Precision Bearing Class			
	O.D.		S		P	
	Over	Incl.	Max.	Min.	Max.	Min.
	mm in.	mm in.	mm in.	mm in.	mm in.	mm in.
TXR	<b>18.000</b>	<b>30.000</b>	<b>0.000</b>	<b>-0.010</b>	<b>0.000</b>	<b>-0.008</b>
	0.7087	1.1811	0.0000	-0.0004	0.0000	-0.0003
	<b>30.000</b>	<b>50.000</b>	<b>0.000</b>	<b>-0.013</b>	<b>0.000</b>	<b>-0.010</b>
	1.1811	1.9685	0.0000	-0.0005	0.0000	-0.0004
	<b>50.000</b>	<b>80.000</b>	<b>0.000</b>	<b>-0.015</b>	<b>0.000</b>	<b>-0.010</b>
	1.9685	3.1496	0.0000	-0.0006	0.0000	-0.0004
	<b>80.000</b>	<b>120.000</b>	<b>0.000</b>	<b>-0.020</b>	<b>0.000</b>	<b>-0.013</b>
	3.1496	4.7244	0.0000	-0.0008	0.0000	-0.0005
	<b>120.000</b>	<b>180.000</b>	<b>0.000</b>	<b>-0.025</b>	<b>0.000</b>	<b>-0.013</b>
	4.7244	7.0866	0.0000	-0.0010	0.0000	-0.0005
	<b>180.000</b>	<b>250.000</b>	<b>0.000</b>	<b>-0.030</b>	<b>0.000</b>	<b>-0.015</b>
	7.0866	9.8425	0.0000	-0.0012	0.0000	-0.0006
	<b>250.000</b>	<b>400.000</b>	<b>0.000</b>	<b>-0.040</b>	<b>0.000</b>	<b>-0.020</b>
	9.8425	15.7480	0.0000	-0.0016	0.0000	-0.0008
	<b>400.000</b>	<b>630.000</b>	<b>0.000</b>	<b>-0.050</b>	<b>0.000</b>	<b>-0.025</b>
	15.7480	24.8031	0.0000	-0.0020	0.0000	-0.0010
<b>630.000</b>	<b>800.000</b>	<b>0.000</b>	<b>-0.060</b>	-	-	
24.8031	31.4961	0.0000	-0.0024	-	-	
<b>800.000</b>	<b>1000.000</b>	<b>0.000</b>	<b>-0.080</b>	-	-	
31.4961	39.3701	0.0000	-0.0031	-	-	
<b>1000.000</b>	<b>1200.000</b>	<b>0.000</b>	<b>-0.100</b>	-	-	
39.3701	47.2441	0.0000	-0.0039	-	-	
<b>1200.000</b>	<b>1600.000</b>	<b>0.000</b>	<b>-0.120</b>	-	-	
47.2441	62.9921	0.0000	-0.0047	-	-	
<b>1600.000</b>	<b>2000.000</b>	<b>0.000</b>	<b>-0.140</b>	-	-	
62.9921	78.7402	0.0000	-0.0055	-	-	
<b>2000.000</b>	-	<b>0.000</b>	<b>-0.140</b>	-	-	
78.7402	-	0.0000	-0.0055	-	-	

**TABLE 32.**  
**METRIC BEARING TOLERANCES - INNER RACE BORE**

Bearing Types	Inner Race Bore		Precision Bearing Class			
	Bore		S		P	
	Over	Incl.	Max.	Min.	Max.	Min.
	mm in.	mm in.	mm in.	mm in.	mm in.	mm in.
TXR	<b>10.000</b>	<b>50.000</b>	<b>0.000</b>	<b>-0.013</b>	<b>0.000</b>	<b>-0.010</b>
	0.3937	1.9685	0.0000	-0.0005	0.0000	-0.0004
	<b>50.000</b>	<b>80.000</b>	<b>0.000</b>	<b>-0.015</b>	<b>0.000</b>	<b>-0.013</b>
	1.9685	3.1496	0.0000	-0.0006	0.0000	-0.0005
	<b>80.000</b>	<b>120.000</b>	<b>0.000</b>	<b>-0.020</b>	<b>0.000</b>	<b>-0.013</b>
	3.1496	4.7244	0.0000	-0.0008	0.0000	-0.0005
	<b>120.000</b>	<b>180.000</b>	<b>0.000</b>	<b>-0.025</b>	<b>0.000</b>	<b>-0.013</b>
	4.7244	7.0866	0.0000	-0.0010	0.0000	-0.0005
	<b>180.000</b>	<b>250.000</b>	<b>0.000</b>	<b>-0.030</b>	<b>0.000</b>	<b>-0.015</b>
	7.0866	9.8425	0.0000	-0.0012	0.0000	-0.0006
	<b>250.000</b>	<b>315.000</b>	<b>0.000</b>	<b>-0.035</b>	<b>0.000</b>	<b>-0.018</b>
	9.8425	12.4016	0.0000	-0.0014	0.0000	-0.0007
	<b>315.000</b>	<b>400.000</b>	<b>0.000</b>	<b>-0.040</b>	<b>0.000</b>	<b>-0.020</b>
	12.4016	15.7480	0.0000	-0.0016	0.0000	-0.0008
	<b>400.000</b>	<b>500.000</b>	<b>0.000</b>	<b>-0.045</b>	<b>0.000</b>	<b>-0.025</b>
	15.7480	19.6850	0.0000	-0.0018	0.0000	-0.0010
	<b>500.000</b>	<b>630.000</b>	<b>0.000</b>	<b>-0.050</b>	<b>0.000</b>	<b>-0.030</b>
19.6850	24.8031	0.0000	-0.0020	0.0000	-0.0012	
<b>630.000</b>	<b>800.000</b>	<b>0.000</b>	<b>-0.060</b>	–	–	
24.8031	31.4961	0.0000	-0.0024	–	–	
<b>800.000</b>	<b>1000.000</b>	<b>0.000</b>	<b>-0.080</b>	–	–	
31.4961	39.3701	0.0000	-0.0031	–	–	
<b>1000.000</b>	<b>1200.000</b>	<b>0.000</b>	<b>-0.100</b>	–	–	
39.3701	47.2441	0.0000	-0.0039	–	–	
<b>1200.000</b>	<b>1600.000</b>	<b>0.000</b>	<b>-0.120</b>	–	–	
47.2441	62.9921	0.0000	-0.0047	–	–	
<b>1600.000</b>	<b>2000.000</b>	<b>0.000</b>	<b>-0.140</b>	–	–	
62.9921	78.7402	0.0000	-0.0055	–	–	
<b>2000.000</b>	–	<b>0.000</b>	<b>-0.140</b>	–	–	
78.7402	–	0.0000	-0.0055	–	–	

## INCH SYSTEM BEARINGS

Inch system bearings are manufactured to a number of tolerance classes. Classes 3, 0, 00 and 000 are "precision" classes.

**TABLE 33.**  
**INCH BEARING TOLERANCES - CONE BORE**

Bearing Types <sup>(1)</sup>	Cone Bore		Precision Bearing Class							
	Bore		3		0		00		000	
	Over	Incl.	Max.	Min.	Max.	Min.	Max.	Min.	Max.	Min.
	mm in.	mm in.	mm in.	mm in.	mm in.	mm in.	mm in.	mm in.	mm in.	mm in.
TS TSF TSL <sup>(2)</sup> TDI TDIT TDO TNA	<b>0.000</b>	<b>76.200</b>	<b>+0.013</b>	<b>0.000</b>	<b>+0.013</b>	<b>0.000</b>	<b>+0.008</b>	<b>0.000</b>	<b>+0.008</b>	<b>0.000</b>
	0.0000	3.0000	+0.0005	0.0000	+0.0005	0.0000	+0.0003	0.0000	+0.0003	0.0000
	<b>76.200</b>	<b>304.800</b>	<b>+0.013</b>	<b>0.000</b>	<b>+0.013</b>	<b>0.000</b>	<b>+0.008</b>	<b>0.000</b>	<b>+0.008</b>	<b>0.000</b>
	3.0000	12.0000	+0.0005	0.0000	+0.0005	0.0000	+0.0003	0.0000	+0.0003	0.0000
	<b>304.800</b>	<b>609.600</b>	<b>+0.025</b>	<b>0.000</b>	-	-	-	-	-	-
	12.0000	24.0000	+0.0010	0.0000	-	-	-	-	-	-
	<b>609.600</b>	<b>914.400</b>	<b>+0.038</b>	<b>0.000</b>	-	-	-	-	-	-
	24.0000	36.0000	+0.0015	0.0000	-	-	-	-	-	-
	<b>914.400</b>	<b>1219.200</b>	<b>+0.051</b>	<b>0.000</b>	-	-	-	-	-	-
	36.0000	48.0000	+0.0020	0.0000	-	-	-	-	-	-
	<b>1219.200</b>		<b>+0.076</b>	<b>0.000</b>	-	-	-	-	-	-
	48.0000		+0.0030	0.0000	-	-	-	-	-	-

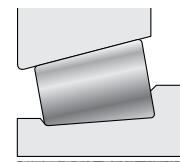

**TABLE 34.**  
**INCH SYSTEM BEARINGS - CUP O.D.**

Bearing Types <sup>(1)</sup>	Cup O.D.		Precision Bearing Class							
	Cup O.D.		3		0		00		000	
	Over	Incl.	Max.	Min.	Max.	Min.	Max.	Min.	Max.	Min.
	mm in.	mm in.	mm in.	mm in.	mm in.	mm in.	mm in.	mm in.	mm in.	mm in.
TS TSF TSL TDI TDIT TDO TNA TNASW TNASWE	<b>0.000</b>	<b>304.800</b>	<b>+0.013</b>	<b>0.000</b>	<b>+0.013</b>	<b>0.000</b>	<b>+0.008</b>	<b>0.000</b>	<b>+0.008</b>	<b>0.000</b>
	0.0000	12.0000	+0.0005	0.0000	+0.0005	0.0000	+0.0003	0.0000	+0.0003	0.0000
	<b>304.800</b>	<b>609.600</b>	<b>+0.025</b>	<b>0.000</b>	<b>+0.013</b>	<b>0.000</b>	<b>+0.008</b>	<b>0.000</b>	<b>+0.008</b>	<b>0.000</b>
	12.0000	24.0000	+0.0010	0.0000	+0.0005	0.0000	+0.0003	0.0000	+0.0003	0.0000
	<b>609.600</b>	<b>914.400</b>	<b>+0.038</b>	<b>0.000</b>	-	-	-	-	-	-
	24.0000	36.0000	+0.0015	0.0000	-	-	-	-	-	-
	<b>914.400</b>	<b>1219.200</b>	<b>+0.051</b>	<b>0.000</b>	-	-	-	-	-	-
	36.0000	48.0000	+0.0020	0.0000	-	-	-	-	-	-
	<b>1219.200</b>		<b>+0.076</b>	<b>0.000</b>	-	-	-	-	-	-
	48.0000		+0.0030	0.0000	-	-	-	-	-	-

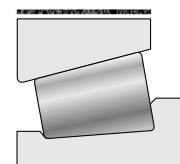

<sup>(1)</sup>Not all types and sizes are listed in this catalog. Contact your Timken representative for further information.

<sup>(2)</sup>For TSL bearings these are the normal tolerances of cone bore. However, bore size can be slightly reduced at large end due to tight fit assembly of the seal on the rib. This should not have any effect on the performance of the bearing.

**TABLE 35.**  
**INCH SYSTEM BEARINGS - CUP FLANGE O.D.**

Bearing Types <sup>(1)</sup>	Cup Flange O.D.		Precision Bearing Class							
	Cup O.D.		3		0		00		000	
	Over	Incl.	Max.	Min.	Max.	Min.	Max.	Min.	Max.	Min.
	mm in.	mm in.	mm in.	mm in.	mm in.	mm in.	mm in.	mm in.	mm in.	mm in.
TSF	0.000	304.800	+0.051	0.000	+0.051	0.000	+0.051	0.000	+0.051	0.000
	0.0000	12.0000	+0.0020	0.0000	+0.0020	0.0000	+0.0020	0.0000	+0.0020	0.0000
	304.800	609.600	+0.076	0.000	+0.051	0.000	+0.051	0.000	+0.051	0.000
	12.0000	24.0000	+0.0030	0.0000	+0.0020	0.0000	+0.0020	0.0000	+0.0020	0.0000
	609.600	914.400	+0.102	0.000	-	-	-	-	-	-
	24.0000	36.0000	+0.0040	0.0000	-	-	-	-	-	-
	914.400		+0.127	0.000	-	-	-	-	-	-
	36.0000		+0.0050	0.0000	-	-	-	-	-	-

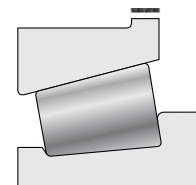

**TABLE 36.**  
**INCH SYSTEM BEARINGS - CONE WIDTH**

Bearing Types <sup>(1)</sup>	Cone Width		Precision Bearing Class							
	Bore		3		0		00		000	
	Over	Incl.	Max.	Min.	Max.	Min.	Max.	Min.	Max.	Min.
	mm in.	mm in.	mm in.	mm in.	mm in.	mm in.	mm in.	mm in.	mm in.	mm in.
TS TSF TSL TDI TDIT TDO	All sizes		+0.076	-0.254	+0.076	-0.254	+0.076	-0.254	+0.076	-0.254
			+0.0030	-0.0100	+0.0030	-0.0100	+0.0030	-0.0100	+0.0030	-0.0100

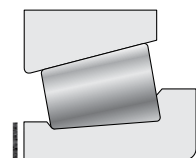

**TABLE 37.**  
**INCH SYSTEM BEARINGS - CUP WIDTH**

Bearing Types <sup>(1)</sup>	Cup Width		Precision Bearing Class							
	Bore		3		0		00		000	
	Over	Incl.	Max.	Min.	Max.	Min.	Max.	Min.	Max.	Min.
	mm in.	mm in.	mm in.	mm in.	mm in.	mm in.	mm in.	mm in.	mm in.	mm in.
All types	All sizes		+0.051	-0.254	+0.051	-0.254	+0.051	-0.254	+0.051	-0.254
			+0.0020	-0.0100	+0.0020	-0.0100	+0.0020	-0.0100	+0.0020	-0.0100

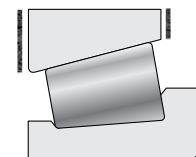

<sup>(1)</sup>Not all types and sizes are listed in this catalog. Contact your Timken representative for further information.



**TABLE 38.**  
**INCH SYSTEM BEARINGS - CONE STAND**

Bearing Types <sup>(1)</sup>	Cone Stand		Precision Bearing Class							
	Bore		3		0		00		000	
	Over	Incl.	Max.	Min.	Max.	Min.	Max.	Min.	Max.	Min.
	mm in.	mm in.	mm in.	mm in.	mm in.	mm in.	mm in.	mm in.	mm in.	mm in.
TS TSF TSL TDI TDIT TDO	<b>0.000</b>	<b>101.600</b>	<b>+0.102</b>	<b>-0.102</b>						
	0.0000	4.0000	+0.0040	-0.0040						
	<b>101.600</b>	<b>266.700</b>	<b>+0.102</b>	<b>-0.102</b>	(2)	(2)	(2)	(2)	(2)	(2)
	4.0000	10.5000	+0.0040	-0.0040						
	<b>266.700</b>	<b>304.800</b>	<b>+0.102</b>	<b>-0.102</b>						
	10.5000	12.0000	+0.0040	-0.0040						
	<b>304.800</b>	<b>406.400</b>	<b>+0.102</b>	<b>-0.102</b>	-	-	-	-	-	-
	12.0000	16.0000	+0.0040	-0.0040	-	-	-	-	-	-
	<b>406.400</b>		(2)	(2)	-	-	-	-	-	-
	16.0000				-	-	-	-	-	-

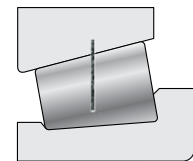

Cone Stand. Cone stand is a measure of the variation in cone raceway size, taper and roller diameter. This is checked by measuring the axial location of the reference surface of a master cup or other type gage with respect to the reference cone face.

**TABLE 39.**  
**INCH SYSTEM BEARINGS - CUP STAND**

Bearing Types <sup>(1)</sup>	Cup Stand		Precision Bearing Class							
	Bore		3		0		00		000	
	Over	Incl.	Max.	Min.	Max.	Min.	Max.	Min.	Max.	Min.
	mm in.	mm in.	mm in.	mm in.	mm in.	mm in.	mm in.	mm in.	mm in.	mm in.
TS TSF <sup>(3)</sup> TSL TDI TDIT	<b>0.000</b>	<b>101.600</b>	<b>+0.102</b>	<b>-0.102</b>						
	0.0000	4.0000	+0.0040	-0.0040						
	<b>101.600</b>	<b>266.700</b>	<b>+0.102</b>	<b>-0.102</b>	(2)	(2)	(2)	(2)	(2)	(2)
	4.0000	10.5000	+0.0040	-0.0040						
	<b>266.700</b>	<b>304.800</b>	<b>+0.102</b>	<b>-0.102</b>						
	10.5000	12.0000	+0.0040	-0.0040						
	<b>304.800</b>	<b>406.400</b>	<b>+0.102</b>	<b>-0.102</b>	-	-	-	-	-	-
	12.0000	16.0000	+0.0040	-0.0040	-	-	-	-	-	-
	<b>406.400</b>		(2)	(2)	-	-	-	-	-	-
	16.0000				-	-	-	-	-	-

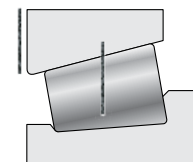

Cup Stand. Cup stand is a measure of the variation in cup I.D. size and taper. This is checked by measuring the axial location of the reference surface of a master plug or other type gage with respect to the reference face of the cup.

<sup>(1)</sup>Not all types and sizes are listed in this catalog. Please contact your Timken representative for further information.

<sup>(2)</sup>These sizes manufactured as matched assemblies only.

<sup>(3)</sup>Stand for flanged cup is measured from flange backface (seating face).

**TABLE 40.**  
**INCH SYSTEM BEARINGS - OVERALL BEARING WIDTH**

Overall Bearing Width					Bearing Class								
Bearing Types <sup>(1)</sup>	Bore		O.D.		3		0		00		000		
	Over	Incl.	Over	Incl.	Max.	Min.	Max.	Min.	Max.	Min.	Max.	Min.	
	mm in.	mm in.	mm in.	mm in.	mm in.	mm in.	mm in.	mm in.	mm in.	mm in.	mm in.	mm in.	
TS TSF <sup>(2)</sup> TSL	<b>0.000</b>	<b>101.600</b>	-	-	<b>+0.203</b>	<b>-0.203</b>	<b>+0.203</b>	<b>-0.203</b>	<b>+0.203</b>	<b>-0.203</b>	<b>+0.203</b>	<b>-0.203</b>	
	0.0000	4.0000	-	-	+0.0080	-0.0080	+0.0080	-0.0080	+0.0080	-0.0080	+0.0080	-0.0080	
	<b>101.600</b>	<b>304.800</b>	-	-	<b>+0.203</b>	<b>-0.203</b>	<b>+0.203</b>	<b>-0.203</b>	<b>+0.203</b>	<b>-0.203</b>	<b>+0.203</b>	<b>-0.203</b>	
	4.0000	12.0000	-	-	+0.0080	-0.0080	+0.0080	-0.0080	+0.0080	-0.0080	+0.0080	-0.0080	
	<b>304.800</b>	<b>609.600</b>	<b>0.000</b>	<b>508.000</b>	<b>+0.203</b>	<b>-0.203</b>	-	-	-	-	-	-	
	12.0000	24.0000	0.0000	20.0000	+0.0080	-0.0080	-	-	-	-	-	-	
	<b>304.800</b>	<b>609.600</b>	<b>508.000</b>	-	<b>+0.381</b>	<b>-0.381</b>	-	-	-	-	-	-	
	12.0000	24.0000	20.0000	-	+0.0150	-0.0150	-	-	-	-	-	-	
	<b>609.600</b>	-	-	-	<b>+0.381</b>	<b>-0.381</b>	-	-	-	-	-	-	
	24.0000	-	-	-	+0.0150	-0.0150	-	-	-	-	-	-	
	TNA TNASW TNASWE	<b>0.000</b>	<b>127.000</b>	-	-	<b>+0.254</b>	<b>0.000</b>	-	-	-	-	-	-
		0.0000	5.0000	-	-	+0.0100	0.0000	-	-	-	-	-	-
<b>127.000</b>		-	-	-	<b>+0.762</b>	<b>0.000</b>	-	-	-	-	-	-	
5.0000		-	-	-	+0.0300	0.0000	-	-	-	-	-	-	
TDI TDIT TDO	<b>0.000</b>	<b>101.600</b>	-	-	<b>+0.406</b>	<b>-0.406</b>	<b>+0.406</b>	<b>-0.406</b>	<b>+0.406</b>	<b>-0.406</b>	<b>+0.406</b>	<b>-0.406</b>	
	0.0000	4.0000	-	-	+0.0160	-0.0160	+0.0160	-0.0160	+0.0160	-0.0160	+0.0160	-0.0160	
	<b>101.600</b>	<b>304.800</b>	-	-	<b>+0.406</b>	<b>-0.406</b>	<b>+0.406</b>	<b>-0.406</b>	<b>+0.406</b>	<b>-0.406</b>	<b>+0.406</b>	<b>-0.406</b>	
	4.0000	12.0000	-	-	+0.0160	-0.0160	+0.0160	-0.0160	+0.0160	-0.0160	+0.0160	-0.0160	
	<b>304.800</b>	<b>609.600</b>	<b>0.000</b>	<b>508.000</b>	<b>+0.406</b>	<b>-0.406</b>	-	-	-	-	-	-	
	12.0000	24.0000	0.0000	20.0000	+0.0160	-0.0160	-	-	-	-	-	-	
	<b>304.800</b>	<b>609.600</b>	<b>508.000</b>	-	<b>+0.762</b>	<b>-0.762</b>	-	-	-	-	-	-	
	12.0000	24.0000	20.0000	-	+0.0300	-0.0300	-	-	-	-	-	-	
	<b>609.600</b>	-	-	-	<b>+0.762</b>	<b>-0.762</b>	-	-	-	-	-	-	
	24.0000	-	-	-	+0.0300	-0.0300	-	-	-	-	-	-	

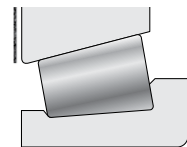

**TABLE 41.**  
**INCH SYSTEM BEARINGS - ASSEMBLED BEARING MAXIMUM RADIAL RUNOUT**

Assembled Bearing Maximum Radial Runout				Bearing Class			
Bearing Types <sup>(1)</sup>	Cup O.D.		3	0	00	000	
	Over	Incl.					
	mm in.	mm in.					
TS TSF TSL TDI TDIT TDO TNA TNASW TNASWE	<b>0.000</b>	<b>266.700</b>	<b>0.008</b>	<b>0.004</b>	<b>0.002</b>	<b>0.001</b>	
	0.0000	10.5000	0.0003	0.00015	0.000075	0.000040	
	<b>266.700</b>	<b>304.800</b>	<b>0.008</b>	<b>0.004</b>	<b>0.002</b>	<b>0.001</b>	
	10.5000	12.0000	0.0003	0.00015	0.000075	0.000040	
	<b>304.800</b>	<b>609.600</b>	<b>0.018</b>	-	-	-	
	12.0000	24.0000	0.0007	-	-	-	
	<b>609.600</b>	<b>914.400</b>	<b>0.051</b>	-	-	-	
	24.0000	36.0000	0.0020	-	-	-	
	<b>914.400</b>	-	<b>0.076</b>	-	-	-	
	36.0000	-	0.0030	-	-	-	

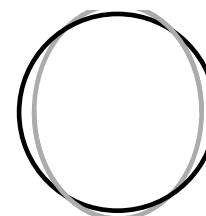

Runout. Runout is a measure of rotational accuracy expressed by Total Indicator Reading (T.I.R.). Total displacement is measured by an instrument sensing against a moving surface, or moved with respect to a fixed surface. A radial runout measurement includes both roundness errors and the centering error of the surface that the instrument head senses against.

<sup>(1)</sup>Not all types and sizes are listed in this catalog. Please contact your Timken representative for further information.

<sup>(2)</sup>For bearing type TSF, the tolerance applies to the dimension T<sub>1</sub>.

**TABLE 42.**  
**INCH SYSTEM BEARINGS - OUTER RACE O.D.**

Bearing Types	Outer Race O.D.		Precision Bearing Class			
	O.D.		3		0	
	Over	Incl.	Max.	Min.	Max.	Min.
	mm in.	mm in.	mm in.	mm in.	mm in.	mm in.
TXR	-	<b>304.800</b>	<b>0.025</b>	<b>0.000</b>	<b>0.127</b>	<b>0.000</b>
	-	12.0000	0.0010	0.0000	0.0005	0.0000
	<b>304.800</b>	<b>609.600</b>	<b>0.051</b>	<b>0.000</b>	<b>0.025</b>	<b>0.000</b>
	12.0000	24.0000	0.0020	0.0000	0.0010	0.0000
	<b>609.600</b>	<b>914.400</b>	<b>0.076</b>	<b>0.000</b>	-	-
	24.0000	36.0000	0.0030	0.0000	-	-
	<b>914.400</b>	<b>1219.200</b>	<b>0.102</b>	<b>0.000</b>	-	-
	36.0000	48.0000	0.0040	0.0000	-	-
	<b>1219.200</b>	<b>1524.000</b>	<b>0.127</b>	<b>0.000</b>	-	-
	48.0000	60.0000	0.0050	0.0000	-	-
	<b>1524.000</b>	-	<b>0.127</b>	<b>0.000</b>	-	-
	60.0000	-	0.0050	0.0000	-	-

**TABLE 43.**  
**INCH SYSTEM BEARINGS - INNER RACE BORE**

Bearing Types	Inner Race Bore		Precision Bearing Class			
	Bore		3		0	
	Over	Incl.	Max.	Min.	Max.	Min.
	mm in.	mm in.	mm in.	mm in.	mm in.	mm in.
TXR	-	<b>76.200</b>	<b>0.013</b>	<b>0.000</b>	<b>0.013</b>	<b>0.000</b>
	-	3.0000	0.0005	0.0000	0.0005	0.0000
	<b>76.200</b>	<b>304.800</b>	<b>0.025</b>	<b>0.000</b>	<b>0.013</b>	<b>0.000</b>
	3.0000	12.0000	0.0010	0.0000	0.0005	0.0000
	<b>304.800</b>	<b>609.600</b>	<b>0.051</b>	<b>0.000</b>	<b>0.025</b>	<b>0.000</b>
	12.0000	24.0000	0.0020	0.0000	0.0010	0.0000
	<b>609.600</b>	<b>914.400</b>	<b>0.076</b>	<b>0.000</b>	-	-
	24.0000	36.0000	0.0030	0.0000	-	-
	<b>914.400</b>	<b>1219.200</b>	<b>0.102</b>	<b>0.000</b>	-	-
	36.0000	48.0000	0.0040	0.0000	-	-
	<b>1219.200</b>	-	<b>0.127</b>	<b>0.000</b>	-	-
	48.0000	-	0.0050	0.0000	-	-

## BALL BEARINGS

The Annular Bearing Engineers' Committee has established five classes of tolerances for ball bearings, known as ABEC 1, ABEC 3, ABEC 5, ABEC 7 and ABEC 9. The highest number indicates the class with the most exacting tolerances. Every ball bearing manufactured by Timken is made to close tolerances, adhering to the established ABEC standards.

In general, these standards are equivalent to the comparable classes of tolerance established by the International Organization for Standardization, known as ISO P0 (ABEC 1), ISO P5 (ABEC 5), ISO P4 (ABEC 7) and ISO P2 (ABEC 9).

Timken manufactures a complete line of super precision ball bearings made to ABEC 7 (ISO P4) and ABEC 7/9 (ISO P4/P2) tolerances for applications involving high speeds, extreme accuracy and rigidity. The range of such equipment includes high-grade machine tools, jet engines, computer hardware, robotics and space exploration vehicles. Machine tool bearings, basically single-row construction, are available in four series, named ultra-light (9300/71900/ISO 19), extra-light (9100/7000/ISO 10), light (200/7200/ISO 02) and medium (300/7300/ISO 03), providing a considerable range in external dimension relationships.

The chart below shows the various classes of tolerances for 35.000 mm (1.3779 in.) bore size, light-series bearings (207). To meet the exacting requirements of the machine tool industry, even ABEC 9/ISO P2 tolerances do not represent the ultimate, since some special applications require even higher precision.

## SYSTEM TOLERANCES

Before determining which type and classification of Timken super precision ball bearing is best suited for a particular application, it is important to explore all relevant details of the bearing characteristics, tolerances and mounting, as listed in the catalog data tables. Although cost is another factor, it is not economical to attempt the use of low-precision bearings on an application where extra-high speeds and ultra-precision bearings are required.

Timken precision bearings are manufactured to close tolerances to help assure consistent performance and interchangeability. To take full advantage of this precision product, it is expected that equally close tolerances be used in the production of mounting components ( housings, shafts, spacers, etc.). Therefore, special consideration must be given to the particular details relating to proper shaft and housing fits and the housing design.

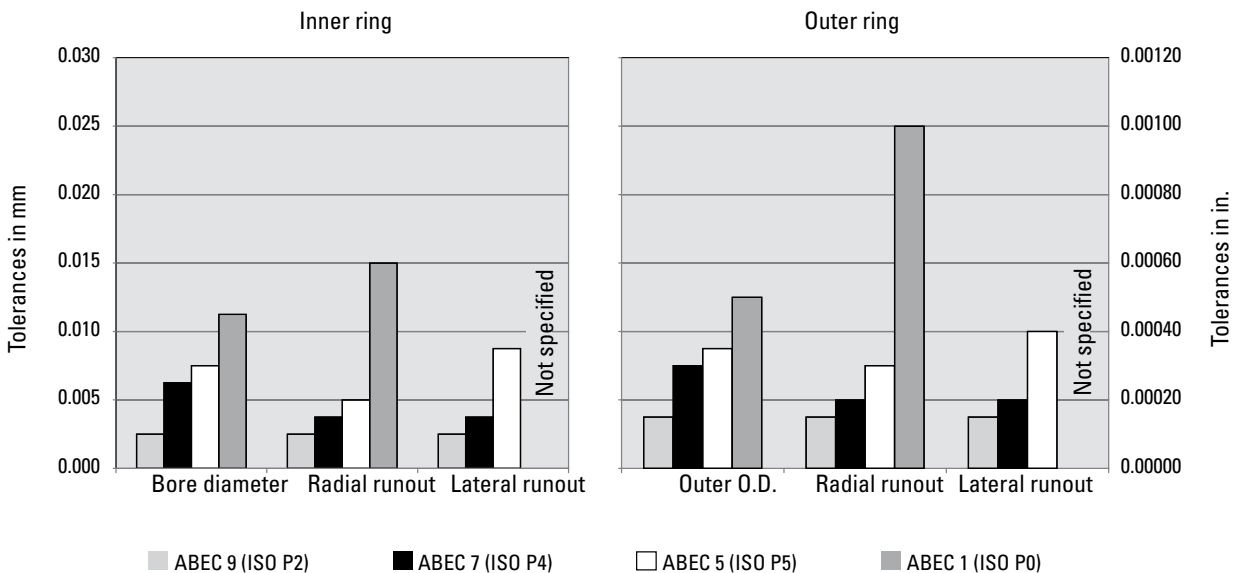

Fig. 68. Comparison of tolerances among ABEC/ISO classes (light series, 35.000 mm bore [1.3779 in.] type).

OUTER, INNER RINGS ABEC 5, 7, 9 – ISO P5, P4, P2

Values of tolerances for super precision ball bearings are shown below. This catalog lists the Timken sizes manufactured to MV (ISO P4) and MM/MMV (ISO P4S) levels.

TABLE 44 .  
STANDARD ABEC/ISO TOLERANCES – INNER RING

Bearing Bore		$\Delta_{dmp}$ Bore Diameter <sup>(1)</sup> +0.000 mm, +0.0000 in.			$V_{Bs}$ Width Variation			$K_{ia}$ Raceway Radial Runout			$S_{ia}$ Raceway Axial Runout			$S_d$ Face Runout With Bore			$\Delta_{Bs}$ Width Inner Rings +0.000 mm, +0.0000 in.
		ABEC/ISO			ABEC/ISO			ABEC/ISO			ABEC/ISO			ABEC/ISO			ABEC/ISO
Over	Incl.	5/P5	7/P4 <sup>(2)</sup>	9/P2	5/P5	7/P4	9/P2 <sup>(2)</sup>	5/P5	7/P4	9/P2 <sup>(2)</sup>	5/P5	7/P4	9/P2 <sup>(2)</sup>	5/P5	7/P4	9/P2 <sup>(2)</sup>	5/P5, 7/P4, 9/P2 <sup>(2)</sup>
mm in.	mm in.	mm in.	mm in.	mm in.	mm in.	mm in.	mm in.	mm in.	mm in.	mm in.	mm in.	mm in.	mm in.	mm in.	mm in.	mm in.	mm in.
2.500	10.000	-0.005	-0.004	-0.0025	0.005	0.0025	0.0015	0.004	0.0025	0.0015	0.007	0.003	0.0015	0.007	0.003	0.0015	-0.040
0.0984	0.3937	-0.0002	-0.0002	-0.0001	0.0002	0.0001	0.0001	0.0002	0.0001	0.0001	0.0003	0.0001	0.00005	0.0003	0.0001	0.00005	-0.0015
10.000	18.000	-0.005	-0.004	-0.0025	0.005	0.0025	0.0015	0.004	0.0025	0.0015	0.007	0.003	0.0015	0.007	0.003	0.0015	-0.080
0.3937	0.7087	-0.0002	-0.0002	-0.0001	0.0002	0.0001	0.0001	0.0002	0.0001	0.0001	0.0003	0.0001	0.00005	0.0003	0.0001	0.00005	-0.0030
18.000	30.000	-0.006	-0.005	-0.0025	0.005	0.0025	0.0015	0.004	0.003	0.0025	0.008	0.004	0.0025	0.008	0.004	0.0015	-0.120
0.7087	1.1811	-0.0002	-0.0002	-0.0001	0.0002	0.0001	0.0001	0.0002	0.0001	0.0001	0.0003	0.0002	0.0001	0.0003	0.0002	0.00005	-0.0050
30.000	50.000	-0.008	-0.006	-0.0025	0.005	0.003	0.0015	0.005	0.004	0.0025	0.008	0.004	0.0025	0.008	0.004	0.0015	-0.120
1.1811	1.9685	-0.0003	-0.0002	-0.0001	0.0002	0.0001	0.0001	0.0002	0.00015	0.0001	0.0003	0.0002	0.0001	0.0003	0.0002	0.00005	-0.0050
50.000	80.000	-0.009	-0.007	-0.004	0.006	0.004	0.0015	0.005	0.004	0.0025	0.008	0.005	0.0025	0.008	0.005	0.0015	-0.150
1.9685	3.1496	-0.0004	-0.0003	-0.00015	0.0002	0.00015	0.0001	0.0002	0.00015	0.0001	0.0003	0.0002	0.0001	0.0003	0.0002	0.00005	-0.0060
80.000	120.000	-0.010	-0.008	-0.005	0.007	0.004	0.0025	0.006	0.005	0.0025	0.009	0.005	0.0025	0.009	0.005	0.0025	-0.200
3.1496	4.7244	-0.0004	-0.0003	-0.0002	0.0003	0.00015	0.0001	0.0002	0.0002	0.0001	0.00035	0.0002	0.0001	0.00035	0.0002	0.0001	-0.0080
120.000	150.000	-0.013	-0.010	-0.007	0.008	0.005	0.0025	0.008	0.006	0.0025	0.010	0.007	0.0025	0.010	0.006	0.0025	-0.250
4.7244	5.9055	-0.0005	-0.0004	-0.0003	0.0003	0.0002	0.0001	0.0003	0.00025	0.0001	0.0004	0.0003	0.0001	0.0004	0.00025	0.0001	-0.0100
150.000	180.000	-0.013	-0.010	-0.007	0.008	0.005	0.004	0.008	0.006	0.005	0.010	0.007	0.005	0.010	0.006	0.004	-0.250
5.9055	7.0866	-0.0005	-0.0004	-0.0003	0.0003	0.0002	0.00015	0.0003	0.00025	0.0002	0.0004	0.0003	0.0002	0.0004	0.00025	0.00015	-0.0100
180.000	250.000	-0.015	-0.012	-0.008	0.010	0.006	0.005	0.010	0.008	0.005	0.013	0.008	0.005	0.011	0.007	0.005	-0.300
7.0866	9.8425	-0.0006	-0.0004	-0.0003	0.0004	0.00025	0.0002	0.0004	0.0003	0.0002	0.0005	0.0003	0.0002	0.00045	0.0003	0.0002	-0.0120

The tolerances in this table are in conformance with ANSI ABMA Standard 20 - 1996.

<sup>(1)</sup> $d_{min}$  (the smallest single diameter of a bore) and  $d_{max}$  (the largest single diameter of a bore) may fall outside limits shown.  $\frac{d_{min} + d_{max}}{2}$  must be within bore diameter tabulated.

<sup>(2)</sup>MM/MMV (P4S) tolerance.

**ABMA / ISO Symbols - Inner Ring**

- $\Delta_{dmp}$  Single plane mean bore diameter deviation from basic bore diameter, e.g., bore tolerance for a basically tapered bore,  $\Delta_{dmp}$  refers only to the theoretical small bore end of the bore
- $K_{ia}$  Radial runout of assembled bearing inner ring, e.g., radial runout of raceway
- $V_{Bs}$  Inner ring width variation, e.g., parallelism
- $S_d$  Inner ring reference face runout with bore, e.g., squareness - bore to face
- $S_{ia}$  Axial runout of assembled bearing inner ring, e.g., lateral (axial) runout of raceway
- $\Delta_{Bs}$  Inner ring width deviation from basic, e.g., width tolerance

WIDTH TOLERANCES

The width tolerances for individual inner and outer rings are shown in the tables below. To allow for the preload grinding on bearings for various preloads, the total width tolerances of duplex sets are as shown in the table to the right. The total width tolerance is proportional to the number of bearings. Note the Timken values are significantly tighter than ABMA/ISO requirements.

TABLE 45.  
PRELOADED DUPLEX SET WIDTH TOLERANCE

Nominal Bore		Width Tolerance (Duplex Set)			
Over	Incl.	ABMA/ISO		Timken	
		Max.	Min.	Max.	Min.
mm in.	mm in.	mm in.	mm in.	mm in.	mm in.
0.000	80.000	0.000	-0.500	0.000	-0.250
0.0000	3.1496	0.0000	-0.0196	0.0000	-0.0100
80.000	180.000	0.000	-0.760	0.000	-0.250
3.1496	7.0866	0.0000	-0.0300	0.0000	-0.0100
180.000	250.000	0.000	-1.000	0.000	-0.250
7.0866	9.8425	0.0000	-0.0394	0.0000	-0.0100

TABLE 46.  
STANDARD ABEC/ISO TOLERANCES – OUTER RING

Bearing O.D.		$\Delta_{Dmp}$ Outside Diameter <sup>(1)</sup> +0.000 mm, +0.0000 in.			$V_{Cs}$ Width Variation			$K_{ea}$ Raceway Radial Runout			$S_{ea}$ Raceway Axial Runout			$S_D$ Face Runout With O.D.			$\Delta_{Cs}$ Width Outer Rings +0.000 mm, +0.0000 in.
Over	Incl.	ABEC/ISO			ABEC/ISO			ABEC/ISO			ABEC/ISO			ABEC/ISO			ABEC/ISO
		5/P5	7/P4 <sup>(3)</sup>	9/P2	5/P5	7/P4	9/P2 <sup>(3)</sup>	5/P5	7/P4	9/P2 <sup>(3)</sup>	5/P5	7/P4	9/P2 <sup>(3)</sup>	5/P5	7/P4	9/P2 <sup>(3)</sup>	5/P5, 7/P4, 9/P2 <sup>(3)</sup>
mm in.	mm in.	mm in.	mm in.	mm in.	mm in.	mm in.	mm in.	mm in.	mm in.	mm in.	mm in.	mm in.	mm in.	mm in.	mm in.	mm in.	mm in.
6.000	18.000	-0.005	-0.004	-0.0025	0.005	0.0025	0.0015	0.005	0.003	0.0015	0.008	0.005	0.0015	0.008	0.004	0.0015	
0.2362	0.7087	-0.0002	-0.00015	-0.0001	0.0002	0.0001	0.00005	0.0002	0.0001	0.00005	0.0003	0.0002	0.00005	0.0003	0.00015	0.00005	
18.000	30.000	-0.006	-0.005	-0.004	0.005	0.0025	0.0015	0.006	0.004	0.0025	0.008	0.005	0.0025	0.008	0.004	0.0015	
0.7087	1.1811	-0.00025	-0.0002	-0.00015	0.0002	0.0001	0.00005	0.00025	0.00015	0.0001	0.0003	0.0002	0.0001	0.0003	0.00015	0.00005	
30.000	50.000	-0.007	-0.006	-0.004	0.005	0.0025	0.0015	0.007	0.005	0.0025	0.008	0.005	0.0025	0.008	0.004	0.0015	
1.1811	1.9685	-0.0003	-0.0002	-0.00015	0.0002	0.0001	0.00005	0.0003	0.0002	0.0001	0.0003	0.0002	0.0001	0.0003	0.00015	0.00005	
50.000	80.000	-0.009	-0.007	-0.004	0.006	0.003	0.0015	0.008	0.005	0.004	0.010	0.005	0.004	0.008	0.004	0.0015	
1.9685	3.1496	-0.00035	-0.0003	-0.00015	0.00025	0.0001	0.00005	0.0003	0.0002	0.00015	0.0004	0.0002	0.00015	0.0003	0.00015	0.00005	
80.000	120.000	-0.010	-0.008	-0.005	0.008	0.004	0.0025	0.010	0.006	0.005	0.011	0.006	0.005	0.009	0.005	0.0025	(2)
3.1496	4.7244	-0.0004	-0.0003	-0.0002	0.0003	0.00015	0.0001	0.0004	0.00025	0.0002	0.00045	0.00025	0.0002	0.00035	0.0002	0.0001	
120.000	150.000	-0.011	-0.009	-0.005	0.008	0.005	0.0025	0.011	0.007	0.005	0.013	0.007	0.005	0.010	0.005	0.0025	
4.7244	5.9055	-0.00045	-0.00035	-0.0002	0.0003	0.0002	0.0001	0.00045	0.0003	0.0002	0.0005	0.0003	0.0002	0.0004	0.0002	0.0001	
150.000	180.000	-0.013	-0.010	-0.007	0.008	0.005	0.0025	0.013	0.008	0.005	0.014	0.008	0.005	0.010	0.005	0.0025	
5.9055	7.0866	-0.0005	-0.0004	-0.0003	0.0003	0.0002	0.0001	0.0005	0.0003	0.0002	0.00055	0.0003	0.0002	0.0004	0.0002	0.0001	
180.000	250.000	-0.015	-0.011	-0.008	0.010	0.007	0.004	0.015	0.010	0.007	0.015	0.010	0.007	0.011	0.007	0.004	
7.0866	9.8425	-0.0006	-0.00045	-0.0003	0.0004	0.0003	0.00015	0.0006	0.0004	0.0003	0.0006	0.0004	0.0003	0.00045	0.0003	0.00015	
250.000	315.000	-0.018	-0.013	-0.008	0.011	0.007	0.005	0.018	0.011	0.007	0.018	0.010	0.007	0.013	0.008	0.005	
9.8425	12.4016	-0.0007	-0.0005	-0.0003	0.00045	0.0003	0.0002	0.0007	0.00045	0.0003	0.0007	0.0004	0.0003	0.0005	0.0003	0.0002	
315.000	400.000	-0.020	-0.015	-0.010	0.013	0.008	0.007	0.020	0.013	0.008	0.020	0.013	0.008	0.013	0.010	0.007	
12.4016	15.7480	-0.0008	-0.0006	-0.0004	0.0005	0.0003	0.0003	0.0008	0.0005	0.0003	0.0008	0.0005	0.0003	0.0005	0.0004	0.0003	

The tolerances in this table are in conformance with ANSI ABMA Standard 20 - 1996.

(1)  $D_{min}$  (the smallest single diameter of an O.D.) and  $D_{max}$  (the largest single diameter of an O.D.) may fall outside limits shown.  $\frac{D_{min} + D_{max}}{2}$  must be within outside diameter tabulated.

(2) Identical to  $\Delta_{Bs}$  of inner ring of same bearing.

(3) MM/MMV (P4S) tolerance

ABMA / ISO Symbols - Outer Ring	
$\Delta_{Dmp}$	Single plane mean outside diameter deviation from basic outside diameter, e.g., O.D. tolerance
$K_{ea}$	Radial runout of assembled bearing outer ring, e.g., radial runout of raceway
$V_{Cs}$	Outer ring width variation, e.g., parallelism
$S_D$	Outer ring reference face runout with O.D., e.g., squareness O.D. to face
$S_{ea}$	Axial runout of assembled bearing outer ring, e.g., lateral (axial) runout of raceway
$\Delta_{Cs}$	Outer ring width deviation from basic, e.g., width tolerance

## ***FITTING PRACTICES***

### **GENERAL GUIDELINES FOR TAPERED ROLLER BEARINGS**

The design of a tapered roller bearing permits the setting to be achieved during installation (or during running when using a Hydra-Rib), irrespective of the inner and outer ring fits on shaft and housing. This allows the use of the widest possible machining tolerances for shaft and housing and the use of the best possible fits for the inner and outer rings to match the duty of the bearing.

The fitting practice will depend upon the following parameters:

- Precision class of the bearing.
- Type of layout.
- Type and direction of loads.
- Running conditions (vibrations, high speeds).
- Shaft and housing sections and materials.
- Mounting and setting conditions.

Certain table fits may not be adequate for light shaft and housing sections, shafts other than steel, nonferrous housings, critical operation conditions such as high speed, unusual thermal or loading conditions or a combination thereof. Also assembly procedures and the means and ease of obtaining the bearing setting may require special fits. In these cases, experience should be used as a guideline or your Timken representative should be consulted for review and suggestions.

Precision class bearings should be mounted on shafts and in housings which are similarly finished to at least the same precision limits as the bearing bore and O.D. High-quality surface finishes should also be provided.

In the machine tool industry, where almost 100 percent of cases are rotating shaft applications, the general rule is to tight-fit both the inner and outer rings for simple layouts to eliminate any undesirable radial clearance.

***Tapered roller bearing envelope tolerances can be adjusted to the needs of a specific application.***

### **NON-FERROUS HOUSINGS**

Care should be taken when pressing cups into aluminum or magnesium housings to avoid metal pick up. This may result in unsatisfactory fits, backing, and alignment from debris trapped between the cup and backing shoulder. Preferably, the cup should be frozen or the housing heated, or both, during assembly. Also, a special lubricant may be used to ease assembly. In some cases, cups are mounted in steel inserts which are attached to the aluminum or magnesium housings. Table fits may then be used. Where the cup is fitted directly into an aluminum housing, it is suggested that a minimum tight fit of 1.0  $\mu\text{m}$  per mm (0.0010 in. per in.) of cup outside diameter be used. For a magnesium housing, a minimum tight fit of 1.5  $\mu\text{m}$  per mm (0.0015 in. per in.) of cup outside diameter is suggested.



# PRECISION CLASS TAPERED ROLLER BEARINGS

## HYDRA-RIB

The Hydra-Rib cup is designed to be mounted either as a flanged cup or shouldered against the cup backface. The 50.000 mm (1.968 in.) bore assembly does not have a flanged cup and the cup backface must be mounted against the housing shoulder.

### SUGGESTED FITTING GUIDELINES FOR FERROUS SHAFT AND HOUSING

For heavy loads, high speed or shock, contact your Timken representative for further information.

**TABLE 47.**  
**SHAFT O.D. - CLASS C AND CLASS B**

Bearing Bore		Class C				Class B			
Range		Bearing Bore Tolerance	Symbol	Shaft O.D. Deviation	Resultant Fit	Bearing Bore Tolerance	Symbol	Shaft O.D. Deviation	Resultant Fit
Over	Incl.								
mm in.	mm in.	mm in.		mm in.	mm in.	mm in.		mm in.	mm in.
<b>30.000</b>	<b>50.000</b>	<b>-0.010</b>	k5	<b>+0.013</b>	<b>0.023T</b>	<b>-0.08</b>	k5	<b>+0.013</b>	<b>0.021T</b>
		<b>0.000</b>		<b>+0.002</b>	<b>0.002T</b>	<b>0.000</b>		<b>+0.002</b>	<b>0.002T</b>
1.1811	1.9685	-0.0004 0.0000		+0.0005 +0.0001	0.0009T 0.0001T	-0.0003 0.0000		+0.0005 +0.0001	0.0008T 0.0001T
<b>50.000</b>	<b>80.000</b>	<b>-0.012</b>	k5	<b>+0.015</b>	<b>0.027T</b>	<b>-0.009</b>	k5	<b>+0.015</b>	<b>0.024T</b>
		<b>0.000</b>		<b>+0.002</b>	<b>0.002T</b>	<b>0.000</b>		<b>+0.002</b>	<b>0.002T</b>
1.9685	3.1496	-0.0005 0.0000		+0.0006 +0.0001	0.0011T 0.0001T	-0.0004 0.0000		+0.0006 +0.0001	0.0010T 0.0001T
<b>80.000</b>	<b>120.000</b>	<b>-0.015</b>	k5	<b>+0.018</b>	<b>0.033T</b>	<b>-0.010</b>	k5	<b>+0.018</b>	<b>0.028T</b>
		<b>0.000</b>		<b>+0.003</b>	<b>0.003T</b>	<b>0.000</b>		<b>+0.003</b>	<b>0.003T</b>
3.1496	4.7244	-0.0006 0.0000		+0.0007 +0.0001	0.0013T 0.0001T	-0.0004 0.0000		+0.0007 +0.0001	0.0011T 0.0001T
<b>120.000</b>	<b>180.000</b>	<b>-0.018</b>	k5	<b>+0.021</b>	<b>0.039T</b>	<b>-0.013</b>	k5	<b>+0.021</b>	<b>0.034T</b>
		<b>0.000</b>		<b>+0.003</b>	<b>0.003T</b>	<b>0.000</b>		<b>+0.003</b>	<b>0.003T</b>
4.7244	7.0866	-0.0007 0.0000		+0.0008 +0.0001	0.0015T 0.0001T	-0.0005 0.0000		+0.0008 +0.0001	0.0013T 0.0001T
<b>180.000</b>	<b>250.000</b>	<b>-0.022</b>	k5	<b>+0.024</b>	<b>0.046T</b>	<b>-0.015</b>	k5	<b>+0.024</b>	<b>0.039T</b>
		<b>0.000</b>		<b>+0.004</b>	<b>0.004T</b>	<b>0.000</b>		<b>+0.004</b>	<b>0.004T</b>
7.0866	9.8425	-0.0009 0.0000		+0.0010 +0.0002	0.0018T 0.0002T	-0.0006 0.0000		+0.0010 +0.0002	0.0016T 0.0002T

Deviation from nominal (maximum) bearing bore and resultant fit.

T= Tight  
L= Loose

**TABLE 48.**  
**HOUSING BORE - CLASS C AND CLASS B**

Bearing O.D.		Class C				Class B			
Range		Bearing O.D. Tolerance	Symbol	Housing Bore Deviation	Resultant Fit	Bearing O.D. Tolerance	Symbol	Housing Bore Deviation	Resultant Fit
Over	Incl.								
mm in.	mm in.	mm in.		mm in.	mm in.	mm in.		mm in.	mm in.
<b>80.000</b>	<b>120.000</b>	<b>0.000</b>	M5	<b>-0.023</b>	<b>0.023T</b>	<b>0.000</b>	M5	<b>-0.023</b>	<b>0.023T</b>
		<b>-0.013</b>		<b>-0.008</b>	<b>0.005L</b>	<b>-0.010</b>		<b>-0.008</b>	<b>0.002L</b>
3.1496	4.7244	0.0000 -0.0005		-0.0009 -0.0003	0.0009T 0.0002L	0.0000 -0.0004		-0.0009 -0.0003	0.0009T 0.0001L
<b>120.000</b>	<b>150.000</b>	<b>0.000</b>	M5	<b>-0.027</b>	<b>0.027T</b>	<b>0.000</b>	M5	<b>-0.027</b>	<b>0.027T</b>
		<b>-0.015</b>		<b>-0.009</b>	<b>0.006L</b>	<b>-0.011</b>		<b>-0.009</b>	<b>0.002L</b>
4.7244	5.9055	0.0000 -0.0006		-0.0011 -0.0004	0.0011T 0.0002	0.0000 -0.0004		-0.0011 -0.0004	0.0011T 0.0001L
<b>150.000</b>	<b>180.000</b>	<b>0.000</b>	M5	<b>-0.027</b>	<b>0.027T</b>	<b>0.000</b>	M5	<b>-0.027</b>	<b>0.027T</b>
		<b>-0.018</b>		<b>-0.010</b>	<b>0.009L</b>	<b>-0.013</b>		<b>-0.009</b>	<b>0.004L</b>
5.9055	7.0866	0.0000 -0.0007		-0.0011 -0.0004	0.0011T 0.0004L	0.0000 -0.0005		-0.0012 -0.0004	0.0011T 0.0002L
<b>180.000</b>	<b>250.000</b>	<b>0.000</b>	M5	<b>-0.031</b>	<b>0.031T</b>	<b>0.000</b>	M5	<b>-0.031</b>	<b>0.031T</b>
		<b>-0.020</b>		<b>-0.011</b>	<b>0.009L</b>	<b>-0.015</b>		<b>-0.011</b>	<b>0.004L</b>
7.0866	9.8425	0.0000 -0.0008		-0.0012 -0.0004	0.0012T 0.0004L	0.0000 -0.0006		-0.0012 -0.0004	0.0012T 0.0002L
<b>250.000</b>	<b>350.000</b>	<b>0.000</b>	M5	<b>-0.036</b>	<b>0.036T</b>	-	-	-	-
		<b>-0.025</b>		<b>-0.013</b>	<b>0.012L</b>	-		-	-
9.8425	10.4331	0.0000 -0.0010		-0.0014 -0.0005	0.0014T 0.0005L	-		-	-

Deviation from nominal (maximum) bearing bore and resultant fit.

T= Tight  
L= Loose

# PRECISION CLASS TAPERED ROLLER BEARINGS (EXCEPT HYDRA-RIB AND TXR BEARINGS)

## SUGGESTED FITTING GUIDELINES FOR FERROUS SHAFT AND HOUSING

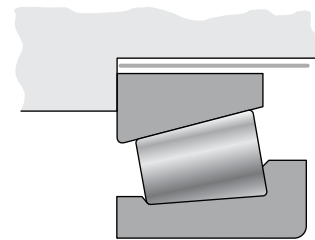

For heavy loads, high speed or shock, contact your Timken representative for further information.

**TABLE 49.**  
**HOUSING BORE METRIC BEARINGS (ISO AND J PREFIX) - CLASS C**

Bearing O.D.			Class C								
Range		Tolerance	Non-Adjustable Or In Carrier			Floating			Adjustable		
Over	Incl.		Symbol	Housing Bore Deviation	Resultant Fit	Symbol	Housing Bore Deviation	Resultant Fit	Symbol	Housing Bore Deviation	Resultant Fit
mm in.	mm in.	mm in.		mm in.	mm in.		mm in.	mm in.		mm in.	mm in.
18.000 0.7087	30.000 1.1811	0.000	N5	-0.021	0.021T	G5	+0.007	0.007L	K5	-0.008	0.008T
		-0.008		-0.012	0.004T		+0.016	0.024L		+0.001	0.009L
		0.0000		-0.0008	0.0008T		+0.0003	0.0003L		-0.0003	0.0003T
		-0.0003		-0.0004	0.0002T		+0.0006	0.0009L		+0.00004	0.0004L
30.000 1.1811	50.000 1.9685	0.000	N5	-0.024	0.024T	G5	+0.009	0.009L	K5	-0.009	0.009T
		-0.009		-0.013	0.004T		+0.020	0.029L		+0.002	0.011L
		0.0000		-0.0009	0.0009T		+0.00035	0.0004L		-0.0004	0.0003T
		-0.0004		-0.0005	0.0002T		+0.0008	0.0011L		+0.0001	0.0004L
50.000 1.9685	80.000 3.1496	0.000	N5	-0.028	0.028T	G5	+0.010	0.010L	K5	-0.010	0.010T
		-0.011		-0.015	0.004T		+0.023	0.034L		+0.003	0.014L
		0.0000		-0.0011	0.0011T		+0.0004	0.0004L		-0.0004	0.0004T
		-0.00045		-0.0006	0.0002T		+0.0009	0.0013L		+0.0001	0.0006L
80.000 3.1496	120.000 4.7244	0.000	N5	-0.033	0.033T	G5	+0.012	0.012L	K5	-0.013	0.013T
		-0.013		-0.018	0.005T		+0.027	0.040L		+0.002	0.015L
		0.0000		-0.0013	0.0013T		+0.0005	0.0008L		-0.0005	0.0005T
		-0.0005		-0.0007	0.0002T		+0.0011	0.0016L		+0.0001	0.0006L
120.000 4.7244	150.000 5.9055	0.000	N5	-0.039	0.039T	G5	+0.014	0.014L	K5	-0.015	0.015T
		-0.015		-0.021	0.006T		+0.032	0.047L		+0.003	0.018L
		0.0000		-0.0015	0.0015T		+0.0006	0.0006L		-0.0006	0.0006T
		-0.0006		-0.0008	0.0002T		+0.0013	0.0019L		+0.0001	0.0007L
150.000 5.9055	180.000 7.0866	0.000	N5	-0.039	0.039T	G5	+0.014	0.014L	K5	-0.015	0.015T
		-0.018		-0.021	0.003T		+0.032	0.050L		+0.003	0.021L
		0.0000		-0.0015	0.0015T		+0.0006	0.0006L		-0.0006	0.0006T
		-0.0007		-0.0008	0.0001T		+0.0013	0.0020T		+0.0001	0.0008L
180.000 7.0866	250.000 9.8425	0.000	N5	-0.045	0.045T	G5	+0.015	0.015L	K5	-0.018	0.018T
		-0.020		-0.025	0.005T		+0.035	0.055L		+0.002	0.027L
		0.0000		-0.0018	0.0018T		+0.0006	0.0006L		-0.0007	0.0007T
		-0.0008		-0.0010	0.0002T		+0.0014	0.0022L		+0.0001	0.0011L
250.000 9.8425	315.000 12.4016	0.000	N5	-0.050	0.050T	G5	+0.017	0.017L	K5	-0.020	0.020T
		-0.025		-0.027	0.002T		+0.040	0.065L		+0.003	0.028L
		0.0000		-0.0020	0.0020T		+0.0007	0.0007L		-0.0008	0.0008T
		-0.0010		-0.0011	0.0001T		+0.0016	0.0023L		+0.0001	0.0011L

Deviation from nominal (maximum) bearing bore and resultant fit.

T= Tight  
L= Loose

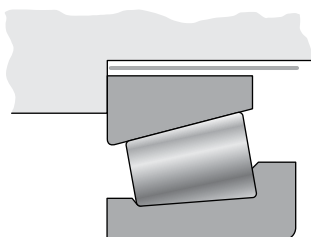
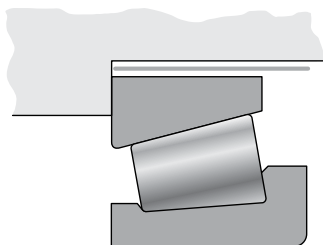

**TABLE 50.**  
**HOUSING BORE METRIC BEARINGS (ISO AND J PREFIX) - CLASS B**

Bearing O.D.			Class B								
Range		Tolerance	Non-Adjustable Or In Carrier			Floating			Adjustable		
Over	Incl.		Symbol	Housing Bore Deviation	Resultant Fit	Symbol	Housing Bore Deviation	Resultant Fit	Symbol	Housing Bore Deviation	Resultant Fit
mm in.	mm in.	mm in.		mm in.	mm in.		mm in.	mm in.		mm in.	mm in.
18.000 0.7087	30.000 1.1811	0.000	M5	-0.014	0.014T	G5	+0.007	0.007L	K5	-0.008	0.008T
		-0.006		-0.005	0.001L		+0.016	0.022L		+0.001	0.007L
		0.0000		-0.0006	0.0006T		+0.0003	0.0003L		-0.0003	0.0003T
		0.0002		-0.0002	0.00004L		+0.0006	0.0009L		+0.00004	0.0003L
30.000 1.1811	50.000 1.9685	0.000	M5	-0.016	0.016T	G5	+0.009	0.009L	K5	-0.009	0.009T
		-0.007		-0.005	0.002L		+0.020	0.027L		+0.002	0.009L
		0.0000		-0.0006	0.0006T		+0.0004	0.0004L		-0.0004	0.0004T
		-0.0003		-0.0002	0.0001L		+0.0008	0.0011L		+0.0001	0.0004L
50.000 1.9685	80.000 3.1496	0.000	M5	-0.019	0.019T	G5	+0.010	0.010L	K5	-0.010	0.010T
		-0.009		-0.006	0.003L		+0.023	0.032L		+0.003	0.012L
		0.000		-0.0008	0.0008T		+0.0004	0.0004L		-0.0004	0.0004T
		-0.0004		-0.0002	0.0001L		+0.0009	0.0013L		+0.0001	0.0005L
80.000 3.1496	120.000 4.7244	0.000	M5	-0.023	0.023T	G5	+0.012	0.012L	K5	-0.013	0.013T
		-0.010		-0.008	0.002L		+0.027	0.037L		+0.002	0.012L
		0.000		0.0009	0.0009T		+0.0005	0.0004L		-0.0005	0.0005T
		-0.0004		0.0003	0.0001L		+0.0011	0.0015L		+0.0001	0.0005L
120.000 4.7244	150.000 5.9055	0.000	M5	-0.027	0.027T	G5	+0.014	0.014L	K5	-0.015	0.015T
		-0.011		-0.009	0.002L		+0.032	0.043L		+0.003	0.012L
		0.000		-0.0011	0.0011T		+0.0006	0.0006L		-0.0006	0.0006T
		-0.0004		-0.0004	0.0001L		+0.0013	0.0017L		+0.0001	0.0005L
150.000 5.9055	180.000 7.0866	0.000	M5	-0.027	0.027T	G5	+0.014	0.014L	K5	-0.015	0.015T
		-0.013		-0.009	0.004L		+0.032	0.045L		+0.003	0.016L
		0.000		-0.0011	0.0011T		+0.0006	0.0006L		-0.0006	0.0006T
		-0.0005		-0.0004	0.0002L		+0.0013	0.0018L		+0.0001	0.0006L
180.000 7.0866	250.000 9.8425	0.000	M5	-0.031	0.031T	G5	+0.015	0.015L	K5	-0.018	0.018T
		-0.015		-0.011	0.004L		+0.035	0.050L		+0.002	0.017L
		0.000		-0.0012	0.0012T		+0.0006	0.0006L		-0.0007	0.0007T
		0.0006		-0.0004	0.0002L		+0.0014	0.0020L		+0.0001	0.0007L
250.000 9.8425	315.000 12.4016	0.000	M5	-0.036	0.036T	G5	+0.017	0.017L	K5	-0.020	0.020T
		-0.018		-0.013	0.005L		+0.040	0.058L		+0.003	0.021L
		0.000		-0.0014	0.0014T		+0.0007	0.0007L		-0.0008	0.0008T
		-0.0007		-0.0005	0.0002L		+0.0016	0.0023L		+0.0001	0.0008L

Deviation from nominal (maximum) bearing bore and resultant fit.

T= Tight  
L = Loose



**TABLE 51.**  
**HOUSING BORE INCH BEARINGS (ISO AND J PREFIX) - CLASS 3 AND 0**

Bearing O.D.			Class 3 and 0 <sup>(1)</sup>					
Range		Tolerance	Non-Adjustable Or In Carrier		Floating		Adjustable	
Over	Incl.		Housing Bore Deviation	Resultant Fit	Housing Bore Deviation	Resultant Fit	Housing Bore Deviation	Resultant Fit
mm in.	mm in.	mm in.	mm in.	mm in.	mm in.	mm in.	mm in.	mm in.
-	152.400	+0.013	-0.013	0.026T	+0.025	0.012L	0.000	0.013T
		0.000	0.000	0.000	+0.038	0.038L	+0.013	0.013L
-	6.0000	+0.0005	-0.0005	0.0010T	+0.0010	0.0005L	0.000	0.0005T
		0.0000	0.0000	0.0000	+0.0015	0.0015L	+0.0005	0.0005L
152.400	304.800	+0.013	-0.025	0.038T	+0.025	0.012L	0.000	0.013T
		0.000	0.000	0.000	+0.038	0.038L	+0.025	0.025L
6.0000	12.0000	+0.0005	-0.0010	0.0015T	+0.0010	0.0005L	0.000	0.0005T
		0.0000	0.0000	0.0000	+0.0015	0.0015L	+0.0010	0.0010L
304.800	609.600	+0.025	-0.025	0.050T	+0.038	0.013L	0.000	0.025T
		0.000	0.000	0.000	+0.064	0.064L	+0.025	0.025L
12.0000	24.0000	+0.0010	-0.0010	0.0020T	+0.0015	0.0005L	0.000	0.0010T
		0.0000	0.0000	0.0000	+0.0025	0.0025L	+0.0010	0.0010L
609.600	914.400	+0.038	-0.038	0.076T	+0.051	0.013L	0.000	0.038T
		0.000	0.000	0.000	+0.089	0.089L	+0.038	0.038L
24.0000	36.0000	+0.0015	-0.0015	0.0030T	+0.0020	0.0005L	0.000	0.0015T
		0.0000	0.0000	0.0000	+0.0035	0.0035L	+0.0015	0.0015L

<sup>(1)</sup>Class 0 made only to 304.800 mm (12.0000 in.) O.D.  
Deviation from nominal (maximum) bearing bore and resultant fit.  
T= Tight  
L = Loose

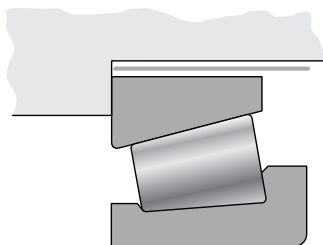

**TABLE 52.**  
**HOUSING BORE INCH BEARINGS - CLASS A AND AA**

Bearing O.D.			Class A and AA					
Range		Tolerance	Non-Adjustable Or In Carrier		Floating		Adjustable	
Over	Incl.		Housing Bore Deviation	Resultant Fit	Housing Bore Deviation	Resultant Fit	Housing Bore Deviation	Resultant Fit
mm in.	mm in.	mm in.	mm in.	mm in.	mm in.	mm in.	mm in.	mm in.
0.000	315.000	-0.000	-0.016	0.016T	+0.008	0.008L	-0.008	0.008T
		-0.008	-0.008	0.000	+0.016	0.024L	-0.000	0.008L
0.0000	12.4016	-0.0000	-0.0006	0.0006T	+0.0003	0.0003L	-0.0003	0.0003T
		-0.0003	-0.0003	0.0000	+0.0006	0.0009L	-0.0000	0.0003L

Deviation from nominal (maximum) bearing bore and resultant fit.  
T= Tight  
L = Loose

**TABLE 53.**  
**HOUSING BORE INCH BEARINGS - CLASS 00 AND 000**

Bearing O.D.			Class 00 and 000					
Range		Tolerance	Non-Adjustable Or In Carrier		Floating		Adjustable	
Over	Incl.		Housing Bore Deviation	Resultant Fit	Housing Bore Deviation	Resultant Fit	Housing Bore Deviation	Resultant Fit
mm in.	mm in.	mm in.	mm in.	mm in.	mm in.	mm in.	mm in.	mm in.
0.000	304.800	+0.008	-0.008	0.016T	+0.015	0.007L	0.000	0.008T
		0.000	0.000	0.000	+0.023	0.023L	+0.008	0.008L
0.0000	12.0000	+0.0003	-0.0003	0.0006T	+0.0006	0.0003L	0.0000	0.0003T
		0.0000	0.0000	0.0000	+0.0009	0.0009L	+0.0003	0.0003L

Deviation from nominal (maximum) bearing bore and resultant fit.  
T= Tight  
L = Loose

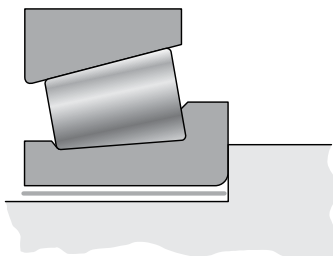

**TABLE 54.**  
**SHAFT O.D. METRIC BEARINGS (ISO AND J PREFIX) - CLASS C AND CLASS B**

Bearing Bore		Class C				Class B				
Over	Incl.	Bearing Bore Tolerance	Symbol	Shaft O.D. Deviation	Resultant Fit	Bearing Bore Tolerance	Symbol	Shaft O.D. Deviation	Resultant Fit	
mm in.	mm in.			mm in.	mm in.			mm in.	mm in.	mm in.
<b>10.000</b>  0.3937	<b>18.000</b>  0.7087	<b>-0.007</b>	k5	<b>+0.009</b>	<b>0.016T</b>	<b>-0.005</b>	k5	<b>+0.009</b>	<b>0.014T</b>	
		<b>0.000</b>		<b>+0.001</b>	<b>0.001T</b>			<b>0.000</b>	<b>+0.001</b>	<b>0.001T</b>
		-0.0003		+0.0004	0.0006T			-0.0002	+0.0004	0.0006T
		0.0000		+0.0004	0.0004T			0.0000	+0.0004	0.0004T
<b>18.000</b>  0.7087	<b>30.000</b>  1.1811	<b>-0.008</b>	k5	<b>+0.011</b>	<b>0.019T</b>	<b>-0.006</b>	k5	<b>+0.011</b>	<b>0.017T</b>	
		<b>0.000</b>		<b>+0.002</b>	<b>0.002T</b>			<b>0.000</b>	<b>+0.002</b>	<b>0.002T</b>
		-0.0003		+0.0005	0.0007T			-0.0002	+0.0004	0.0007T
		0.0000		+0.0001	0.0001T			0.0000	+0.0001	0.0001T
<b>30.000</b>  1.1811	<b>50.000</b>  1.9685	<b>-0.010</b>	k5	<b>+0.013</b>	<b>0.023T</b>	<b>-0.008</b>	k5	<b>+0.013</b>	<b>0.021T</b>	
		<b>0.000</b>		<b>+0.002</b>	<b>0.002T</b>			<b>0.000</b>	<b>+0.002</b>	<b>0.002T</b>
		-0.0004		+0.0005	0.0009T			-0.0003	+0.0005	0.0008T
		0.0000		+0.0001	0.0001T			0.0000	+0.0001	0.0001T
<b>50.000</b>  1.9685	<b>80.000</b>  3.1496	<b>-0.012</b>	k5	<b>+0.015</b>	<b>0.027T</b>	<b>-0.009</b>	k5	<b>+0.015</b>	<b>0.024T</b>	
		<b>0.000</b>		<b>+0.003</b>	<b>0.002T</b>			<b>0.000</b>	<b>+0.002</b>	<b>0.002T</b>
		-0.0005		+0.0006	0.0011T			-0.0004	+0.0006	0.0009T
		0.0000		+0.0001	0.0001T			0.0000	+0.0001	0.0001T
<b>80.000</b>  3.1496	<b>120.000</b>  4.7244	<b>-0.015</b>	k5	<b>+0.018</b>	<b>0.033T</b>	<b>-0.010</b>	k5	<b>+0.018</b>	<b>0.028T</b>	
		<b>0.000</b>		<b>+0.003</b>	<b>0.003T</b>			<b>0.000</b>	<b>+0.003</b>	<b>0.003T</b>
		-0.0006		+0.0007	0.0013T			-0.0004	+0.0007	0.0011T
		0.0000		+0.0001	0.0001T			0.0000	+0.0001	0.0001T
<b>120.000</b>  4.7244	<b>180.000</b>  7.0866	<b>-0.018</b>	k5	<b>+0.021</b>	<b>0.039T</b>	<b>-0.013</b>	k5	<b>+0.021</b>	<b>0.034T</b>	
		<b>0.000</b>		<b>+0.003</b>	<b>0.003T</b>			<b>0.000</b>	<b>+0.003</b>	<b>0.003T</b>
		-0.0007		+0.0008	0.0015T			-0.0005	+0.0008	0.0013T
		0.0000		+0.0001	0.0001T			0.0000	+0.0001	0.0001T
<b>180.000</b>  7.0866	<b>250.000</b>  9.8425	<b>-0.022</b>	k5	<b>+0.024</b>	<b>0.046T</b>	<b>-0.015</b>	k5	<b>+0.024</b>	<b>0.039T</b>	
		<b>0.000</b>		<b>+0.004</b>	<b>0.004T</b>			<b>0.000</b>	<b>+0.004</b>	<b>0.004T</b>
		-0.0009		+0.0009	0.0018T			-0.0006	+0.0009	0.0015T
		0.0000		+0.0002	0.0002T			0.0000	+0.0002	0.0002T
<b>250.000</b>  9.8425	<b>315.000</b>  12.4016	<b>-0.022</b>	k5	<b>+0.027</b>	<b>0.049T</b>	<b>-0.015</b>	k5	<b>+0.027</b>	<b>0.042T</b>	
		<b>0.000</b>		<b>+0.004</b>	<b>0.004T</b>			<b>0.000</b>	<b>+0.004</b>	<b>0.004T</b>
		-0.0009		+0.0011	0.0019T			-0.0006	+0.0011	0.0017T
		0.0000		+0.0002	0.0002T			0.0000	+0.0002	0.0002T

Deviation from nominal (maximum) bearing bore and resultant fit.

T= Tight

L= Loose

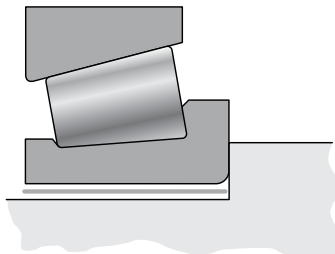

**TABLE 55.**  
**SHAFT O.D. METRIC BEARINGS (ISO AND J PREFIX) - CLASS A AND AA**

Bearing Bore		Class A And AA			
Range		Bearing Bore Tolerance	Symbol	Shaft O.D. Deviation	Resultant Fit
Over	Incl.				
mm	mm	mm		mm	mm
in.	in.	in.		in.	in.
10.000	18.000	-0.005	k4	+0.006	0.011T
		0.000		+0.001	0.001T
		-0.0002		+0.0002	0.0004T
		0.0000		+0.00004	0.00004T
0.3937	0.7087				
18.000	30.000	-0.006	k4	+0.008	0.014T
		0.000		+0.002	0.002T
		-0.0002		+0.0003	0.0006T
		0.0000		+0.0001	0.0001T
0.7087	1.1811				
30.000	315.000	-0.008		+0.013	0.021T
		0.000		+0.005	0.005T
		-0.0003		+0.0005	0.0008T
		0.0000		+0.0002	0.0002T
1.1811	12.4016				

Deviation from nominal (maximum) bearing bore and resultant fit.

T= Tight  
L = Loose

**TABLE 56.**  
**SHAFT O.D. INCH BEARINGS - CLASS 3 AND 0 • CLASS 00 AND 000**

Bearing Bore		Class 3 And 0 <sup>(1)</sup>			Class 00 And 000		
Range		Bearing Bore Tolerance	Shaft O.D. Deviation	Resultant Fit	Bearing Bore Tolerance $\mu\text{m}$ (0.0001 In.)	Shaft O.D. Deviation	Resultant Fit
Over	Incl.						
mm	mm	mm	mm		mm	mm	
in.	in.	in.	in.		in.	in.	
-	304.800	0.000	+0.030	0.030T	0.000	+0.020	0.020T
		+0.013	+0.018	0.005T		+0.013	0.005T
		0.0000	+0.0012	0.0012T		+0.0008	0.0008T
-	12.0000	+0.0005	+0.0007	0.0002T	+0.0003	+0.0005	0.0002T
304.800	609.600	0.000	+0.064	0.064T	-	-	-
		+0.025	+0.038	0.013T		-	-
		0.0000	+0.0025	0.0025T		-	-
12.0000	24.0000	+0.0010	+0.0015	0.0005T			
609.600	914.400	0.000	+0.102	0.102T	-	-	-
		+0.038	+0.064	0.026T		-	-
		0.0000	+0.0040	0.0040T		-	-
24.0000	36.0000	+0.0015	+0.0025	0.0010T			

<sup>(1)</sup>Class 0 made only to 304.800 mm (12.0000 in.) O.D.

Deviation from nominal (maximum) bearing bore and resultant fit.

T= Tight  
L = Loose



# PRECISION CLASS TAPERED ROLLER BEARINGS

TXR

## SUGGESTED FITTING GUIDELINES FOR FERROUS SHAFT AND HOUSING

For heavy loads, high speed or shock, contact your Timken representative for further information.

**TABLE 57.**  
**SHAFT O.D. METRIC BEARINGS - CLASS S • CLASS P**

Bearing Bore		Class S		Class P	
Range		Max.	Min.	Max.	Min.
Over	Incl.				
mm in.	mm in.	mm in.	mm in.	mm in.	mm in.
–	<b>50.000</b>	<b>0.020T</b>	<b>0.007T</b>	<b>0.014T</b>	<b>0.004T</b>
–	1.9685	0.0008T	0.0003T	0.0006T	0.0002T
<b>50.000</b>	<b>80.000</b>	<b>0.025T</b>	<b>0.010T</b>	<b>0.017T</b>	<b>0.004T</b>
1.9685	3.1496	0.0010T	0.0004T	0.0007T	0.0002T
<b>80.000</b>	<b>120.000</b>	<b>0.033T</b>	<b>0.013T</b>	<b>0.017T</b>	<b>0.004T</b>
3.1496	4.7244	0.0013T	0.0005T	0.0007T	0.0002T
<b>120.000</b>	<b>180.000</b>	<b>0.052T</b>	<b>0.027T</b>	<b>0.017T</b>	<b>0.004T</b>
4.7244	7.0866	0.0021T	0.0011T	0.0007T	0.0002T
<b>180.000</b>	<b>250.000</b>	<b>0.060T</b>	<b>0.030T</b>	<b>0.020T</b>	<b>0.004T</b>
7.0866	9.8425	0.0024T	0.0012T	0.0008T	0.0002T
<b>250.000</b>	<b>315.000</b>	<b>0.070T</b>	<b>0.035T</b>	<b>0.022T</b>	<b>0.004T</b>
9.8425	12.4016	0.0028T	0.0014T	0.0009T	0.0002T
<b>315.000</b>	<b>400.000</b>	<b>0.077T</b>	<b>0.037T</b>	<b>0.024T</b>	<b>0.004T</b>
12.4016	15.7480	0.0030T	0.0015T	0.0009T	0.0002T
<b>400.000</b>	<b>500.000</b>	<b>0.085T</b>	<b>0.040T</b>	<b>0.030T</b>	<b>0.004T</b>
15.7480	19.6850	0.0034T	0.0016T	0.0012T	0.0002T

Deviation from nominal (maximum) bearing bore and resultant fit.

T= Tight

L= Loose

**TABLE 58.**  
**HOUSING BORE METRIC BEARINGS - CLASS S • CLASS P**

Bearing O.D.		Class S		Class P	
Range		Max.	Min.	Max.	Min.
Over	Incl.				
mm in.	mm in.	mm in.	mm in.	mm in.	mm in.
–	<b>50.000</b>	<b>0.020T</b>	<b>0.007T</b>	<b>0.014T</b>	<b>0.004T</b>
–	1.9685	0.0008T	0.0003T	0.0006T	0.0002T
<b>50.000</b>	<b>80.000</b>	<b>0.025T</b>	<b>0.010T</b>	<b>0.017T</b>	<b>0.004T</b>
1.9685	3.1496	0.0010T	0.0004T	0.0007T	0.0002T
<b>80.000</b>	<b>120.000</b>	<b>0.033T</b>	<b>0.013T</b>	<b>0.017T</b>	<b>0.004T</b>
3.1496	4.7244	0.0013T	0.0005T	0.0007T	0.0002T
<b>120.000</b>	<b>180.000</b>	<b>0.052T</b>	<b>0.027T</b>	<b>0.017T</b>	<b>0.004T</b>
4.7244	7.0866	0.0021T	0.0011T	0.0007T	0.0002T
<b>180.000</b>	<b>250.000</b>	<b>0.060T</b>	<b>0.030T</b>	<b>0.020T</b>	<b>0.004T</b>
7.0866	9.8425	0.0024T	0.0012T	0.0008T	0.0002T
<b>250.000</b>	<b>315.000</b>	<b>0.070T</b>	<b>0.035T</b>	<b>0.022T</b>	<b>0.004T</b>
9.8425	12.4016	0.0028T	0.0014T	0.0009T	0.0002T
<b>315.000</b>	<b>400.000</b>	<b>0.077T</b>	<b>0.037T</b>	<b>0.024T</b>	<b>0.004T</b>
12.4016	15.7480	0.0030T	0.0015T	0.0009T	0.0002T
<b>400.000</b>	<b>500.000</b>	<b>0.085T</b>	<b>0.040T</b>	<b>0.030T</b>	<b>0.004T</b>
15.7480	19.6850	0.0034T	0.0016T	0.0012T	0.0002T

Deviation from nominal (maximum) bearing bore and resultant fit.

T= Tight

L= Loose

**TABLE 59.**  
**SHAFT O.D. INCH BEARINGS - CLASS 3 • CLASS 0**

Bearing Bore		Class 3		Class 0	
Range		Max.	Min.	Max.	Min.
Over	Incl.				
mm in.	mm in.	mm in.	mm in.	mm in.	mm in.
-	<b>304.800</b>	<b>0.037T</b>	<b>0.013T</b>	<b>0.020T</b>	<b>0.007T</b>
-	12.0000	0.0015T	0.0005T	0.0008T	0.0003T
<b>304.800</b>	<b>609.600</b>	<b>0.077T</b>	<b>0.025T</b>	<b>0.037T</b>	<b>0.013T</b>
12.0000	24.0000	0.0030T	0.0010T	0.0015T	0.0005T
<b>609.600</b>	<b>914.400</b>	<b>0.114T</b>	<b>0.037T</b>	-	-
24.0000	36.0000	0.0045T	0.0015T	-	-
<b>914.400</b>	<b>1219.200</b>	<b>0.152T</b>	<b>0.051T</b>	-	-
36.0000	48.0000	0.0060T	0.0020T	-	-
<b>1219.200</b>	-	<b>0.191T</b>	<b>0.064T</b>	-	-
48.0000	-	0.0075T	0.0025T	-	-

Deviation from nominal (maximum) bearing bore and resultant fit.

T= Tight

L= Loose

**TABLE 60.**  
**HOUSING BORE INCH BEARINGS - CLASS 3 • CLASS 0**

Bearing O.D.		Class 3		Class 0	
Range		Max.	Min.	Max.	Min.
Over	Incl.				
mm in.	mm in.	mm in.	mm in.	mm in.	mm in.
-	<b>304.800</b>	<b>0.037T</b>	<b>0.013T</b>	<b>0.020T</b>	<b>0.007T</b>
-	12.0000	0.0015T	0.0005T	0.0008T	0.0003T
<b>304.800</b>	<b>609.600</b>	<b>0.077T</b>	<b>0.025T</b>	<b>0.037T</b>	<b>0.013T</b>
12.0000	24.0000	0.0030T	0.0010T	0.0015T	0.0005T
<b>609.600</b>	<b>914.400</b>	<b>0.114T</b>	<b>0.037T</b>	-	-
24.0000	36.0000	0.0045T	0.0015T	-	-
<b>914.400</b>	<b>1219.200</b>	<b>0.152T</b>	<b>0.051T</b>	-	-
36.0000	48.0000	0.0060T	0.0020T	-	-
<b>1219.200</b>	-	<b>0.191T</b>	<b>0.064T</b>	-	-
48.0000	-	0.0075T	0.0025T	-	-

Deviation from nominal (maximum) bearing bore and resultant fit.

T= Tight

L= Loose

## SHAFT AND HOUSING CONSIDERATIONS TAPERED ROLLER BEARINGS

In general, machining bearing seats and shoulders in spindles and housings requires careful consideration of the following form and orientation characteristics. The first four characteristics apply to the seats of bearing rings.

- Circularity (roundness) of each seat at every cross section.
- Cylindricity of each seat. Cylindricity includes the taper, roundness and other form characteristics of the seat.
- Coaxiality of the inner ring seats on the spindle and coaxiality of the outer ring seats in the housing. Coaxiality includes offset misalignment and angular misalignment between seats.
- Angularity of each bearing ring seat. This is a consideration when an inner ring seat is tapered.

The following two characteristics apply to the shoulders corresponding to each bearing seat.

- **Perpendicularity** (squareness) of each shoulder to its corresponding bearing seat, or as a more practical measure, perpendicularity of each shoulder to the spindle or housing centerline established from the two bearing seats.
- **Flatness** of each shoulder. A practical way of assessing the combined perpendicularity and flatness of each shoulder is to measure the total runout of the shoulder relative to the spindle or housing centerline. The runout of the face of the adjusting nuts, if used, should also be measured.

The tolerances to which these characteristics should be held are dependent upon the class, size and application of the bearing. *In general, these tolerances should be no greater than the total indicator reading (T.I.R.) of the assembled bearing.*

Some of the characteristics can be difficult to measure precisely. The individual user may elect to measure a subset of these characteristics (roundness and taper as an alternative to cylindricity). The individual user must determine the degree of effort and expense to be invested in the measurements. That determination should be based on the intended application of the bearing and the level of confidence in the machining process employed to manufacture the spindle and housing.

## SURFACE FINISHES – PRECISION BEARINGS

Precision class bearings should be mounted on shafts and in housings that are finished to at least the same precision limits as the bearing bore or outside diameter.

Furthermore, high-quality surface finishes together with close machining tolerances of bearing seats also must be provided. The following tabulations give some guidelines for all these criteria.

**TABLE 61.**  
**SUGGESTED TAPERED ROLLER BEARING SHAFT AND HOUSING FINISHES**

All Sizes	Bearing Class			
	C 3	B 0	A 00	AA 000
	$\mu\text{m}$ $\mu\text{in}$	$\mu\text{m}$ $\mu\text{in}$	$\mu\text{m}$ $\mu\text{in}$	$\mu\text{m}$ $\mu\text{in}$
Shaft - Ra	0.8 32	0.6 24	0.4 16	0.2 8
Housing - Ra	1.6 63	0.8 32	0.6 24	0.4 16

## BALL BEARINGS SHAFT FITS

The main purpose of the shaft fit is to assure a proper attachment of the inner ring to the shaft. Under normal conditions of shaft rotation, a loosely fitted inner ring will creep on the shaft, leading to wear and fretting. This condition will be further aggravated by increase of load or speed. To prevent creeping or slipping, the inner ring should be mounted firmly in place and held securely against the shaft shoulder. However, it is important that the shaft fit should not result in any undue tightening of the bearing. An excessive interference fit of the bearing bore with the shaft could result in a proportionate expansion of the bearing inner ring which could disturb the internal fit of the bearing and lead to heating and increased power consumption.

As a general rule, it is suggested that the shaft size and tolerance for seating super precision ball bearings (ABEC 7/ISO P4 and ABEC 9/ISO P2) be the same as the bearing bore. In the case of preloaded bearings, the suggested shaft fit is line-to-line, since an excessively tight fit expands the bearing inner ring and increases the bearing preload, which can lead to overheating. For example, a duplex pair of 2MM9111WI DUL bearings with 16 kg (35 lbs.) built-in preload, when mounted on a shaft that provides an interference fit of 0.010 mm (0.0004 in.), will increase the preload to approximately 86 kg (180 lbs.), which could result in elevated operating temperatures.

**TABLE 62.**  
**SHAFT FIT EXAMPLE: MMV (ABEC 7/ISO P4)**

Bore Size		Shaft Diameter		Resulting Mounting Fit	
Max	Min.	Max.	Min.	Loose	Tight
mm in.	mm in.	mm in.	mm in.	mm in.	mm in.
55.000	54.994	55.000	54.994	0.004	0.006
2.1654	2.1651	2.1654	2.1651	0.0002	0.0003

## HOUSING FITS

Under normal conditions of rotating shaft, the outer ring is stationary and should be mounted with a hand push to a light tapping fit. Should the housing be the rotating member, the same fundamental considerations apply in mounting the outer ring as in the case of an inner ring mounted on a rotating shaft. Contact your Timken representative for outer ring rotation requirements.

As a general rule, the minimum housing bore dimension for super precision ball bearings may be established as the same as the maximum bearing outside diameter. If the bearing O.D. tolerance is 0.008 mm (0.0003 in.), the maximum housing bore should be established as 0.008 mm (0.0003 in.) larger than the minimum housing bore dimensions.

**TABLE 63.**  
**HOUSING BORE FIT EXAMPLE: MMV (ABEC 7/ISO P4)**

Outside Diameter		Housing Bore		Resulting Mounting Fit		Average Fit	
Max	Min.	Max.	Min.	Loose	Tight	Loose	Loose
mm in.	mm in.	mm in.	mm in.	mm in.	mm in.	mm in.	mm in.
90.000	89.992	90.007	90.000	0.015	0.000	0.006	0.006
3.5433	3.5430	3.5436	3.5433	0.0006	0.0000	0.0003	0.0003

Tables covering suggested shaft and housing seat dimensions for super precision (ABEC 7/ISO P4) ball bearings are shown with part numbers in the product pages.

To accomplish the optimum mounting condition, it is important to follow the tabulated tolerances, except when deviations are suggested by your Timken representative. It is equally important that all shaft and housing shoulders be square and properly relieved to assure accurate seating and positioning of the bearings in the mounting.

On high-speed applications where nearby heat input is along the shaft, it is extremely important that the floating bearings can move axially to compensate for thermal changes. Ball bearings cannot float axially if they are restricted by tight housing bores or by the radial expansion of the bearing itself due to temperature differentials. Therefore, in such cases, the suggested housing mounting fit for the floating bearings is slightly looser than the tabulated average fit.

Likewise, in spring-loaded ball bearing applications, the housing mounting fit must be free enough to permit axial movement of the bearings under the spring pressure during all conditions of operation. The suggested housing dimensions to ensure proper "float" of the bearings under average conditions are listed in the product pages.

# SHAFT AND HOUSING TOLERANCES

## SHAFT GEOMETRY REQUIREMENTS

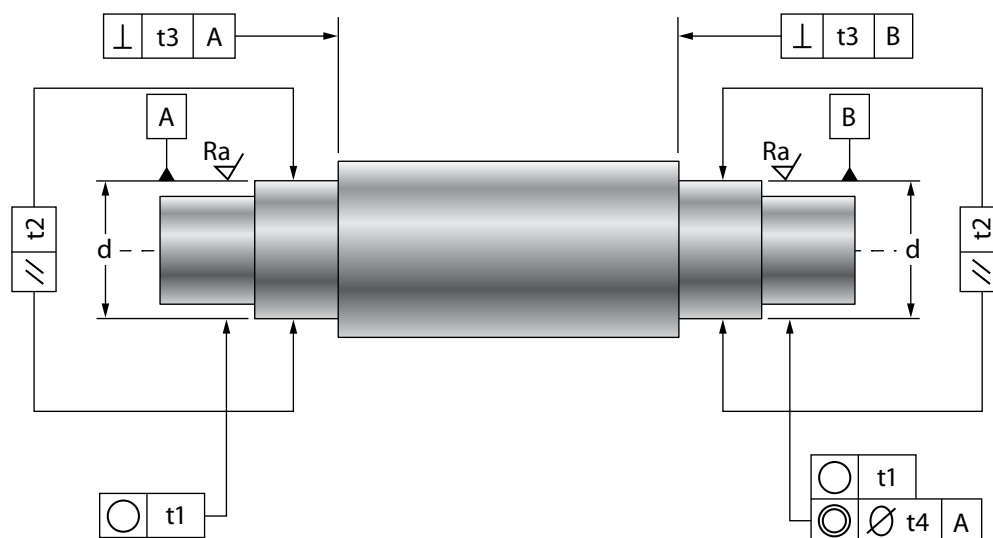

Fig. 69. Shaft Tolerances.

TABLE 64.  
DEFINITION OF TOLERANCE SYMBOLS

Description	Symbol	Tolerance Value	MV ABEC 7 (ISO P4)	MMV/MM ABEC 7/9 (ISO P4S)	MMX ABEC 9 (ISO P2)
Roundness	○	t1	IT2	IT1	IT0
Parallelism	//	t2	IT2	IT1	IT0
Squareness	⊥	t3	IT2	IT1	IT0
Concentricity	⊙	t4	IT3	IT2	IT2
Surface Finish	Ra		16 (μin.)	or	0.4 μm

TABLE 65.  
SHAFT SURFACE FINISH SPECIFICATIONS

Shaft Journal Diameter (d) mm		Units – Micrometer (μm)				Shaft Journal Diameter (d) mm		Units – Microinches (μin.)			
>	≤	IT0	IT1	IT2	IT3	>	≤	IT0	IT1	IT2	IT3
—	10	0.6	1.0	1.5	2.5	—	10	20	40	60	100
10	18	0.8	1.2	2.0	3.0	10	18	30	50	80	120
18	30	1.0	1.5	2.5	4.0	18	30	40	60	100	160
30	50	1.0	1.5	2.5	4.0	30	50	40	60	100	160
50	80	1.2	2.0	3.0	5.0	50	80	50	80	120	200
80	120	1.5	2.5	4.0	6.0	80	120	60	100	160	240
120	180	2.0	3.5	5.0	8.0	120	180	80	140	200	310
180	250	3.0	4.5	7.0	10.0	180	250	120	180	280	390
250	315	—	6.0	8.0	12.0	250	315	—	240	310	470

Reference ISO 286.

HOUSING GEOMETRY REQUIREMENTS

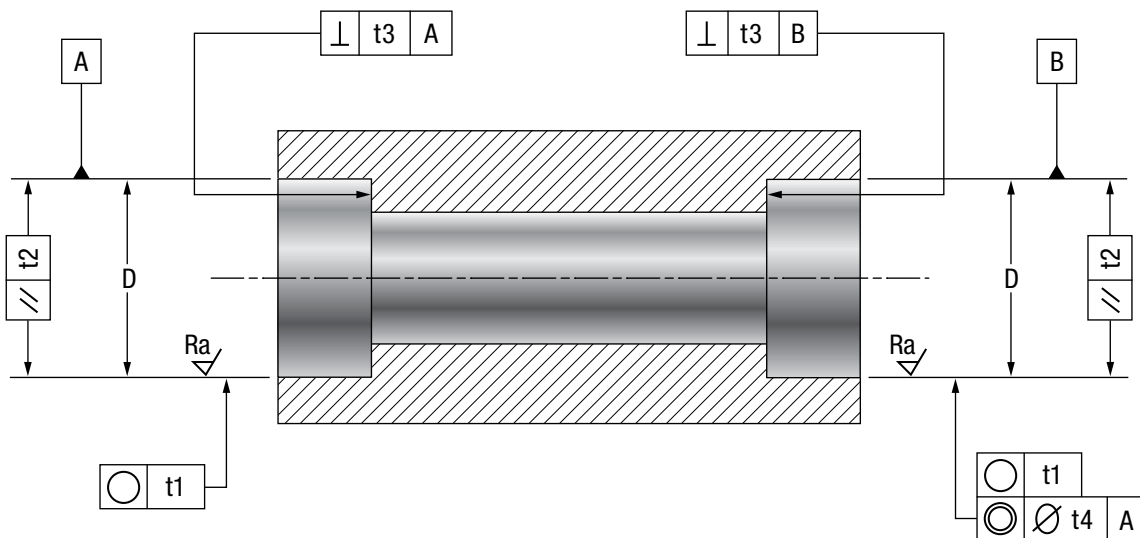

Fig. 70. Housing Tolerances.

TABLE 66. DEFINITION OF TOLERANCE SYMBOLS

Description	Symbol	Tolerance Value	MV ABEC 7 (ISO P4)	MMV/MM ABEC 7/9 (ISO P4S)	MMX ABEC 9 (ISOP2)
Roundness	○	t1	IT2	IT1	IT0
Parallelism	//	t2	IT2	IT1	IT0
Squareness	⊥	t3	IT2	IT1	IT0
Concentricity	⊙	t4	IT3	IT2	IT2
Surface Finish	Ra		16 (μin.)	or	0.4 μm

TABLE 67. HOUSING SURFACE FINISH SPECIFICATIONS

Housing Journal Diameter (D) mm		Units – Micrometer (μm)				Housing Journal Diameter (D) mm		Units – Microinches (μin.)			
>	≤	IT0	IT1	IT2	IT3	>	≤	IT0	IT1	IT2	IT3
10	18	0.8	1.2	2.0	3.0	10	18	30	50	80	120
18	30	1.0	1.5	2.5	4.0	18	30	40	60	100	160
30	50	1.0	1.5	2.5	4.0	30	50	40	60	100	160
50	80	1.2	2.0	3.0	5.0	50	80	50	80	120	200
80	120	1.5	2.5	4.0	6.0	80	120	60	100	160	240
120	180	2.0	3.5	5.0	8.0	120	180	80	140	200	310
180	250	3.0	4.5	7.0	10.0	180	250	120	180	280	390
250	315	3.5	6.0	8.0	12.0	250	315	140	240	310	470
315	400	4.5	6.0	8.0	12.0	315	400	180	240	310	470

Reference ISO 286.

## MOUNTING DESIGNS

Obtaining good spindle accuracy depends not only on selecting the proper precision bearings but also on the following factors:

- Good design and machining of the components that support the bearing (roundness and alignment of the seats, squareness of backing shoulders of both the spindle and the housing, and surface finish).
- Correct use of information given on bearings.
- Correct fitting practices.
- Appropriate bearing setting.

Selection of the most appropriate mounting design is largely dictated by optimizing the stiffness, speedability and ease of assembly.

## DESIGN AND ACCURACY OF MOUNTING SURFACES

The total runout of a spindle-bearing-housing system is a combination of the runout of each component. A precision bearing will assume the shape of the spindle and perpetuate whatever runout is present. If the runout is caused by a defective housing, the spindle and bearing will simply transmit the error to the workpiece. Therefore, particular attention needs to be paid to the design and accuracy of the mounting surfaces.

The primary function of the inner or outer ring seat and abutment is to positively establish the location and alignment of the bearing under all loading and operating conditions. To achieve optimum bearing performance, it is essential to design housing seats and abutments that are round and square in alignment with the spindle axis. Shoulders must be of sufficient section and design to resist axial deflection under load. The shoulder diameters should be respected to help obtain optimum bearing performance.

## HOUSING DESIGN

Housings are usually made of cast iron or steel and are generally heat-treated to lessen possible distortion. For smaller high-speed applications, steel housings are preferred.

The bore of the housing should be ground or bored and checked at a number of points throughout its length and diameter to ensure that it is round and does not taper.

It is preferable to mount the bearings in one casting; this permits machining the two housing bores in one setting, as well as accurate alignment of the bearings.

In many cases of machine design, it is advantageous to employ a subhousing or a steel sleeve between the outer ring of the bearing and the machine frame, thus allowing assembly of the bearings on the shaft and insertion of the entire unit into the machine frame. This method also provides a surface of proper hardness where machine frames are made of a material that has a low Brinell value, such as aluminum and other soft metals.

Shaft shoulders and housing shoulders should be square and true, and should be of such diameters as to meet the suggestions shown with the part numbers given. The choice between fillets and undercut reliefs rests with the individual shaft design and conditions surrounding its normal use. Suggested housing geometry requirements are discussed on pages 83 and 85.

Where screws are used to fasten end caps into the main housing, adequate section should be left between the screw hole and the housing bore. This is required to prevent distortion of the housing bore when the screws are tightened and the covers or others parts are pulled tightly into place.

Prior to assembly, shafts and housings, as well as all lubricant holes and channels, should be cleaned thoroughly to remove all chips and particles that may be carried by the lubricant into the bearings and cause bearing damage.

## HOUSING SEALS

A labyrinth combination of slinger and end cover provides a highly effective seal against the intrusion of foreign matter. This seal is suggested for use over a wide range of speeds. For slower-speed applications, a combination of slinger and a commercial contact-type seal is usually employed.

Slings should be machined all over to assure true-running. Their diameters should be concentric with the bore. The outside diameter of the slinger is often tapered to throw off cutting compounds, coolants, etc., from the point at which such liquids may enter the spindle. A drip or run-off groove adjacent to the open lip of the end cover is highly desirable and practical.

The axial clearances of the internal faces between slinger and end cover should be about 1.600 mm (0.0629 in.). The first radial clearance opening on any design through which liquid may pass should be made very close, about 0.089 mm (0.0035 in.) on a side. The inner radial clearances should be between 0.380 mm (0.0149 in.) and 0.190 mm (0.0075 in.).

## SHAFTS

Shafts are preferably made from hardened and ground steel; and, where suitable, a hardness of 45-50 HRC has been successful. When designing a spindle or shaft, it is highly desirable to plan so that it can be ground all over in one setting as a final operation. This promotes true balance and running accuracy, which are critical in high-speed applications. Suggested shaft geometry can be found on pages 84 and 85.



**Fig. 71. Locking devices.**

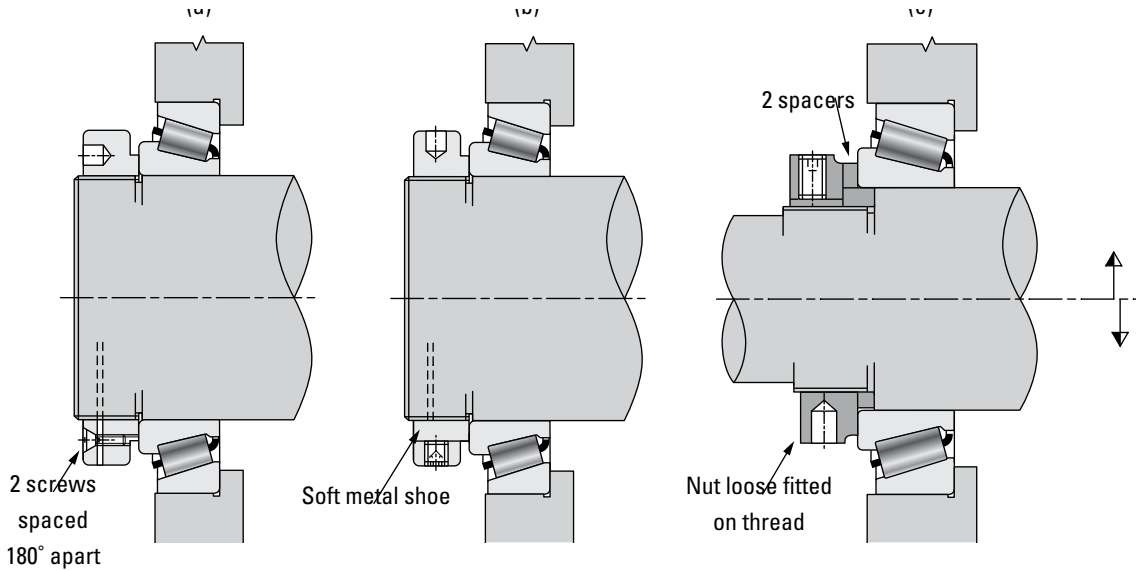

## LOCKING DEVICES

In most cases, simple 2TS(F) spindle layouts are adjusted by correct positioning of the tail bearing cone. A commonly used device is a precision adjusting nut. A locking device must be provided to properly maintain the nut after setting: either axially by means of two screws 180 degrees opposite pinching the threads (Fig. 71a), or radially by pressure of a screw on a soft metal shoe (Fig. 71b).

For improved accuracy, a ground spacer in conjunction with a square-ground spindle shoulder and a locking precision nut also can be used (Fig. 70). Good parallelism of the ground spacer faces as well as the squareness of the spindle shoulder will ensure a perfect positioning of the cone backface. This mounting configuration also offers assurance that the initially defined setting cannot be interfered with by the final user. Fig. 71c shows two different solutions with ground spacers. Note the practicality of the above centerline solution, which allows the spacer to both increase or decrease the initial setting.

A well-known method of providing good spindle alignment, roundness and backing squareness is to grind the cone seats and the backing shoulders during the same operation (Fig. 73). In this method, the grinding of the square backing of the adjusting nut (if any) also can be achieved by locking the nut on its thread. This eliminates any possible default of the nut due to internal thread clearance.

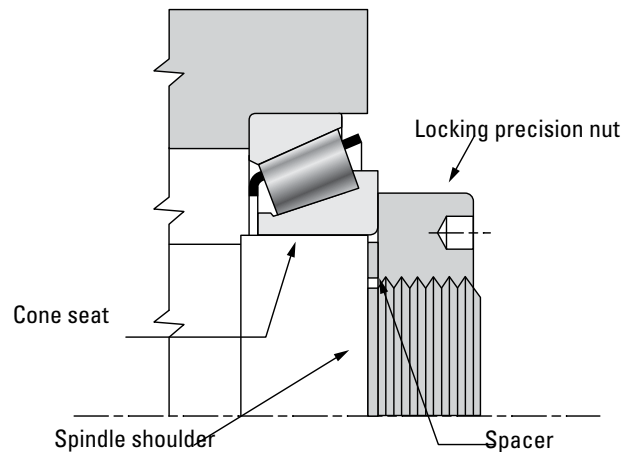

**Fig. 72. Using ground spacer and spindle shoulder together with a precision nut for improved accuracy.**

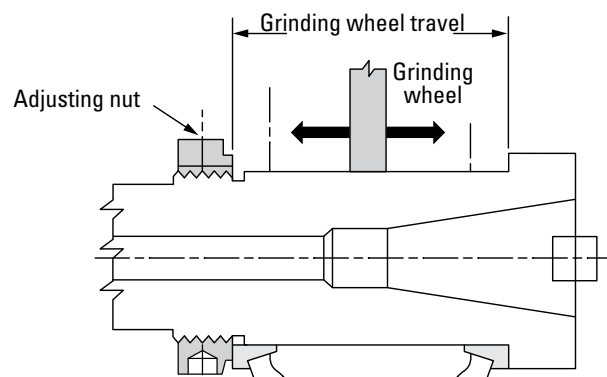

**Fig. 73. Grinding of cone shaft and backing shoulders.**

## TAPERED ROLLER BEARINGS

Tapered roller bearings are generally used in two fundamental spindle design configurations:

- Three-support mountings for heavily loaded or long spindles.
- Simple mounting of two single-row bearings.

## THREE-SUPPORT MOUNTING

Fig. 74 shows the “box type” mounting using three bearings. The two nose bearings are located axially (fixed position) and accept axial forces in both directions, while the tail bearing is fitted as a floating position to accommodate the thermal expansion of the spindle. The floating position can be supported either by a tapered roller bearing or a cylindrical roller bearing.

This kind of arrangement is mainly used for special heavy machines running at low or medium speeds, or for long spindle designs.

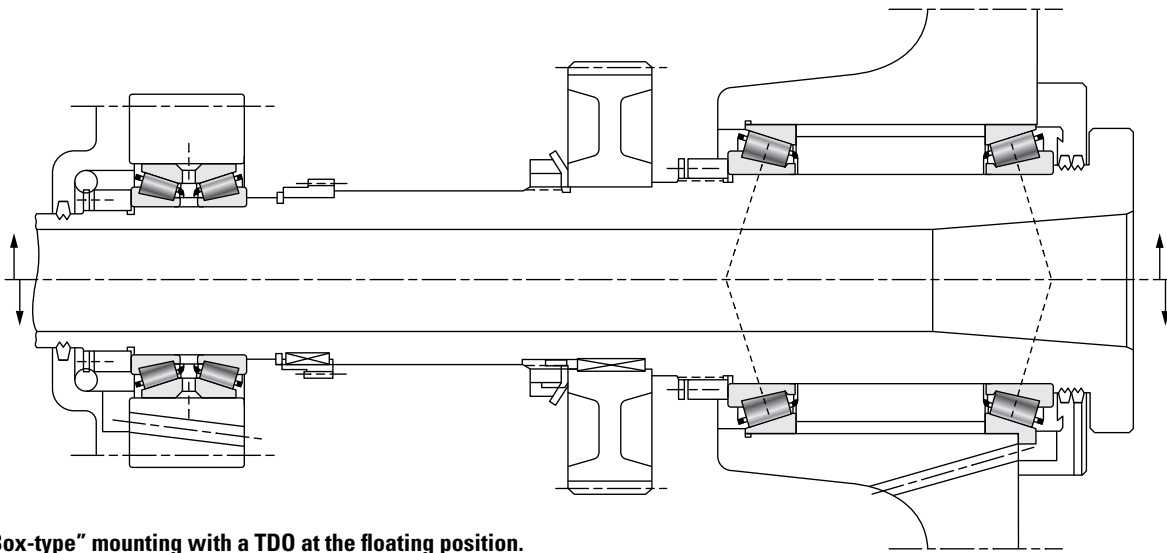

Fig. 74. “Box-type” mounting with a TDO at the floating position.

## SIMPLE MOUNTING

The evolution of two single-row bearing arrangements for spindles, discussed below, is directly related to the speed requirements and, consequently, the lubrication modes (see page 41).

### TS and TSF Arrangement

The spindle is supported by one bearing at the nose position and a second one at the tail position. This layout offers the advantage of being a simple isostatic design that allows easy machining of adjacent parts. The mounting and setting procedures can be achieved without any specific tooling.

Static stiffness calculations of the spindle-bearing system allow the optimum bearing spread to be determined precisely for each mounting, as a function of the overhung value of the spindle nose.

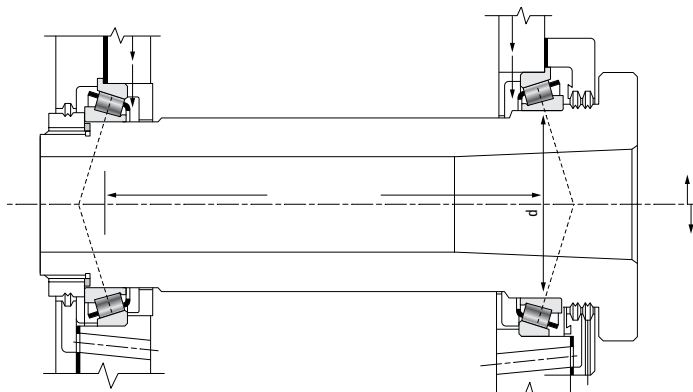

**Fig. 75. Simple mounting with a pair of TS or TSF bearings.**

A good approximation, however, is to consider that the distance between bearing centers should be of two and a half to three times the spindle nose diameter. This represents an optimum value not only for stiffness, but also for thermal equilibrium.

Fig. 75 represents the simplest layout of a two single-row bearing concept. The view above the centerline shows flanged cups (Type TSF) allowing a through-bore machining concept for the housing, which offers increased accuracy with no need for cup backing shoulders. The arrangement shown below the centerline uses two single-row bearings (Type TS).

The bearings are adjusted by means of a ground spacer locked by a precision nut. Lubrication is often achieved by oil circulation, which enters through radial oil inlets or special high-speed grease.

As shown below, the next evolution of this arrangement consists of improving the lubrication system by using appropriate jets for oil inlets and cooling (Fig. 76 and Fig. 77).

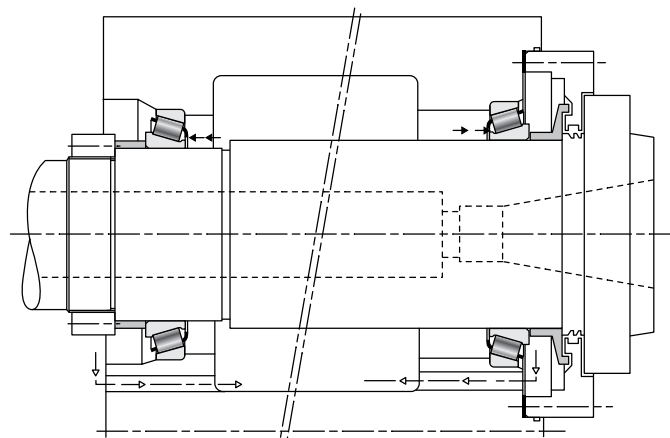

**Fig. 76. Simple paired TS mounting with oil inlet at the small end of the rollers.**

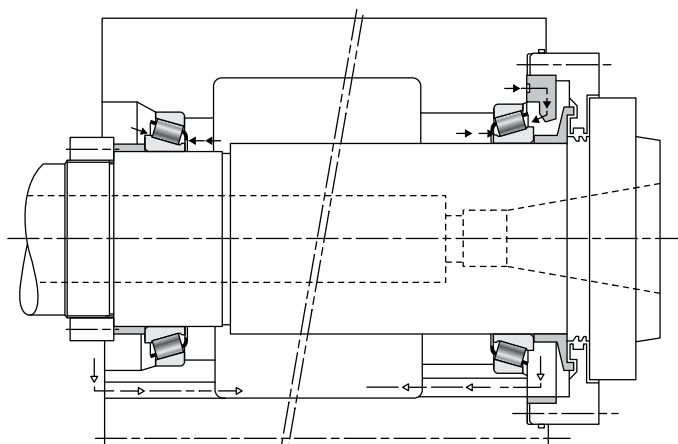

**Fig. 77. Simple paired TS mounting with oil jets at both ends of the rollers for inlet and cooling.**

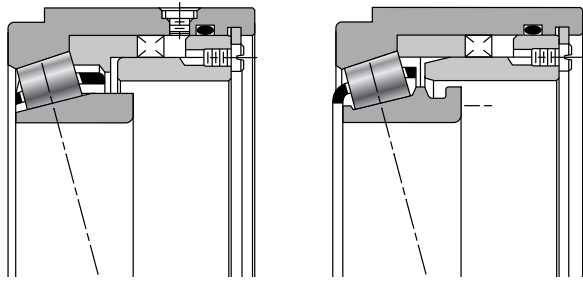

Fig. 78. Two designs of the Hydra-Rib bearing.

**TS(F) and Hydra-Rib**

A typical spindle arrangement is the combination of a Hydra-Rib bearing with a single-row TS bearing (Fig. 79). The Hydra-Rib bearing is fitted at the tail position and the TS bearing at the nose position of the spindle. The outer ring rib simplifies the lubrication at high speed since the natural flow of the oil under centrifugal effect feeds the oil to the rib. A simple axial oil inlet above the cage on the small roller end is therefore sufficient for lubricating the Hydra-Rib bearing.

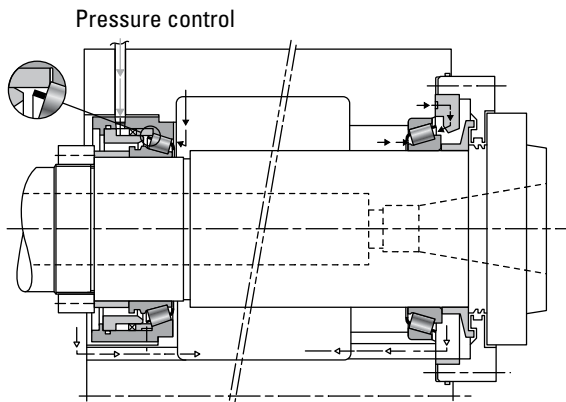

Fig. 79. Simple mounting with a Hydra-Rib cooled by an axial oil inlet and a TS bearing with oil jets at both end of the rollers for inlet and cooling.

**TSMA and Hydra-Rib**

Fig. 80 shows the same arrangement with a TSMA bearing. This arrangement allows the widest range of operating speeds, under optimum preload.

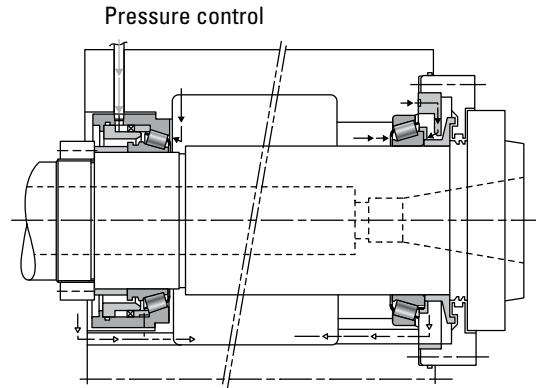
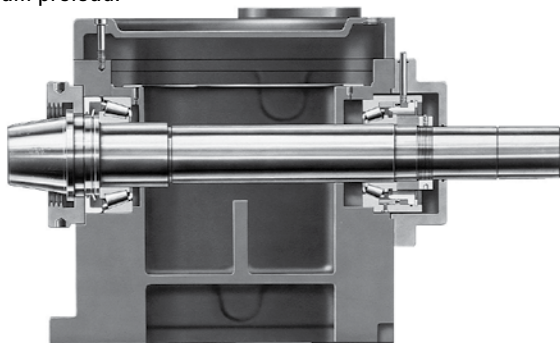

Fig. 80. Simple mounting with a Hydra-Rib bearing cooled by an axial oil inlet and a TSMA bearing with oil jets at both ends of the rollers for inlet and cooling.

**TXR(DO)**

A typical mounting arrangement for the type TXRDO crossed roller bearing is shown in Fig. 81.

The arrangement shown is for lubrication by oil circulation in conjunction with an oil level. It can, however, be designed for grease lubrication with appropriate sealing arrangements.

The bore of the housing (DH) and the diameter of the spigot (DS) (Fig. 82) should be machined to give a mean of the suggested interference fits (pages 80-81).

The bearing is adjusted externally by segments beneath the top inner ring clamping plate (Fig. 82) to get the required preload.

Your Timken representative should be consulted for more details about the use of crossed roller bearings.

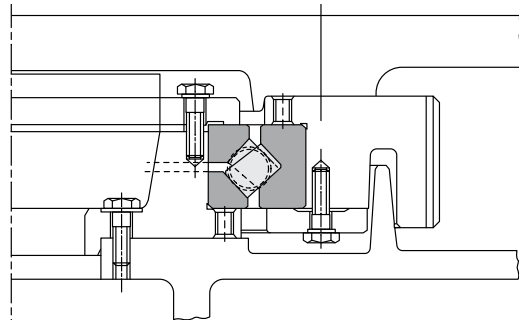

Fig. 81. Typical mounting arrangement of a TXRDO bearing.

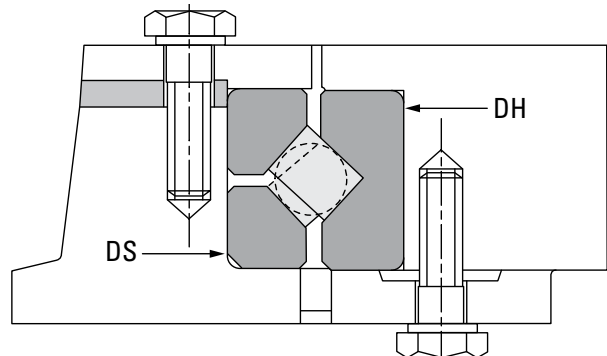

Fig. 82. Fitting and setting of TXR bearings.

## DUPLEX BALL BEARINGS

### BACK-TO-BACK MOUNTING, DB OR ("O") (CONTACT ANGLES DIVERGING TOWARD SHAFT CENTERLINE)

Before mounting, there is clearance between the two adjacent inner ring faces. After mounting, these faces are clamped together to provide an internal preload on each bearing. This arrangement is well-suited for pulleys, sheaves and other applications where there are overturning loads and also all floating positions where thermal expansion of the shaft occurs. It also provides axial and radial rigidity and equal axial capacity in either direction when used in a fixed location. Back-to-back is the most commonly used of all duplex arrangements. Timken pairs for back-to-back mounting should be ordered as DU. Example: 2MM207WI-DU. Also available as two single flush-ground bearings, e.g., -SU (two bearings).

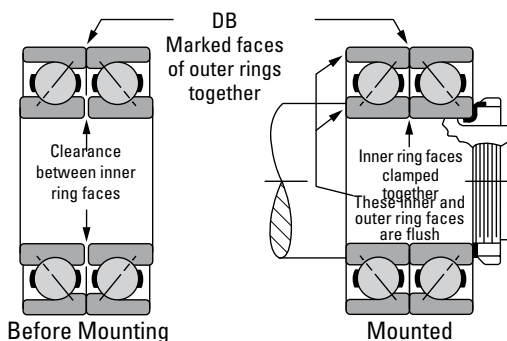

Fig. 83. Back-to-back bearing assemblies before and after mounting.

### FACE-TO-FACE MOUNTING, DF OR ("X") (CONTACT ANGLES CONVERGING TOWARD SHAFT CENTERLINE)

Before mounting, there is clearance between the two adjacent outer ring faces. After mounting, these faces are clamped together between the housing shoulder and cover plate shoulder, providing an internal preload on each bearing. This arrangement provides equal

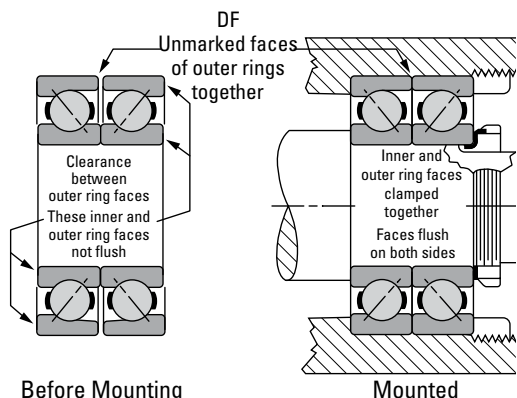

Fig. 84. Face-to-face bearing assemblies before and after mounting.

axial capacity in either direction as well as radial and axial rigidity. Since the face-to-face mounting has inherent disadvantages of low resistance to moment loading and thermal instability, it should not be considered unless a significantly more convenient method of assembly or disassembly occurs from its use. Timken pairs for face-to-face mounting should be ordered as DU. Example: 2MM212WI-DU. Also available as two single flush-ground bearings, e.g., -SU (two bearings).

### TANDEM MOUNTING, DT

Before mounting, the inner ring faces of each bearing are offset from the outer ring faces. After mounting, when an axial load is applied equal to that of twice the normal preload, the inner and outer ring faces are brought into alignment on both sides. This arrangement provides double axial capacity in one direction only. More than two bearings can be used in tandem if additional axial capacity is required. Timken pairs for tandem mounting should be specified as DU. Example: 2MM205WI-DU. Also available as two single flush-ground bearings, e.g., -SU (two bearings).

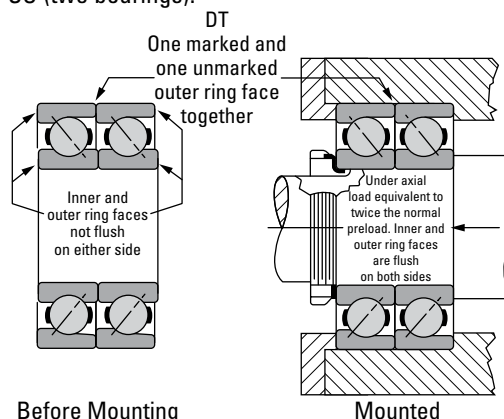

Fig. 85. Tandem bearing assemblies before and after mounting.

### OTHER MOUNTINGS

Flush-ground (DU) pairs may be mounted in combination with a single flush-ground bearing as a "triplex" (TU) set shown below. Also shown below is a "quadruplex" (QU) set where three bearings in tandem are mounted back-to-back with a single bearing. These arrangements provide high capacity in one direction and also a positively rigid mounting capable of carrying a moderate amount of reverse thrust.

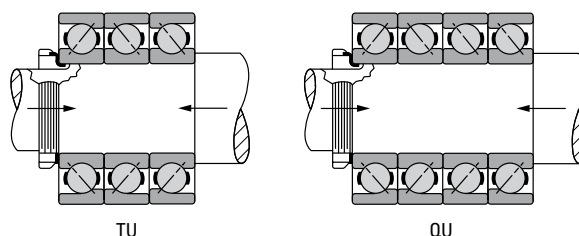

Fig. 86. Typical triplex and quadruplex bearing mountings.

## BACK-TO-BACK VERSUS FACE-TO-FACE MOUNTINGS

Mountings having bearings applied in any of the face-to-face (DF) arrangements are objectionable because they provide the least rigidity. Furthermore, when the operating speeds are comparatively high, such mountings may buildup bearing preload excessively because of the temperature gradient between the housings, bearings and shafts. As this gradient increases, the bearing preload builds up, starting a detrimental cycle that may lead to premature spindle damage.

In spindle mountings, the shaft temperature usually changes at a faster rate than the housing, creating temperature differentials between the two members. These are due to their difference in mass and their respective abilities to act as heat sinks. Thus, the shaft and the inner-ring spacer expand at a faster rate than the housing and the outer-ring spacer. As the shaft expands longitudinally and the inner-ring spacer lengthens, an axial load builds up on each bearing and continues to increase until the equilibrium temperature is reached. This occurs when the temperature at the housing levels off and the heat transferred from the bearings balances the heat generated within the system. Therefore, if the housing attains an excessively high temperature, the initial bearing temperature is built up considerably.

In a face-to-face mounting, Fig. 87, the shaft expands radially and longitudinally and the inner-ring spacer lengthens, but at a faster rate than the outer-ring spacer. This thermal expansion causes an additional axial load to be imposed on both inner rings, increasing the preload of the bearings. Conversely, in back-to-back mounting, Fig. 88, the longitudinal expansion of the inner-ring spacer tends to relieve, rather than build up, the bearing preload.

The two back-to-back pairs, shown in Fig. 89, are mounted so that the two middle bearings are face-to-face. As previously observed, temperature differentials cause the preload of these inner bearings to increase during operation. This mounting operation is not suggested. In bearing mountings of the system seen in Fig. 90, undue axial loads are put on the two outer bearings as the temperature along the shaft becomes higher than at the housing. The two inner bearings unload, starting a vicious cycle of increasing temperature, preload buildup and lubricant breakdown. This also is an unacceptable mounting arrangement and is not suggested. The same bearings are shown correctly mounted in tandem and arranged back-to-back in Fig. 91. Lateral expansion of the shaft and inner-ring spacer of such mountings increases neither axial loading nor bearing preload.

*Therefore, to prevent increases in preload due to the thermal expansion, back-to-back mountings are preferred for bearings on machine tool spindles. When two pairs are used, each pair should be mounted in tandem, but the combination should be arranged back-to-back as in Fig. 91.*

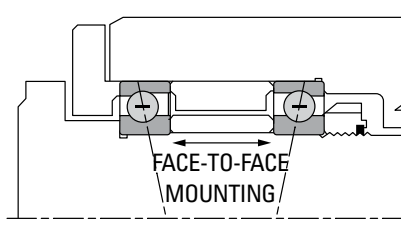

Fig. 87. DF Mounting, fixed (not suggested).

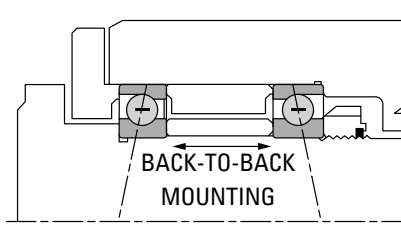

Fig. 88. DB Mounting, fixed (suggested).

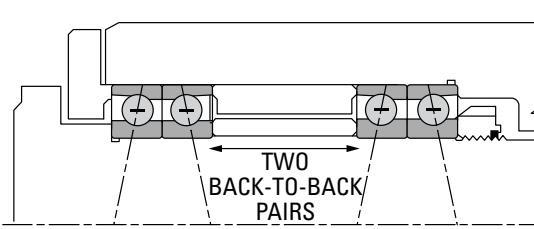

Fig. 89. DB-DB Mounting, fixed (not suggested).

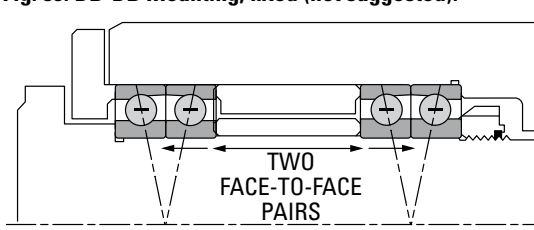

Fig. 90. DF-DF Mounting, fixed (not suggested).

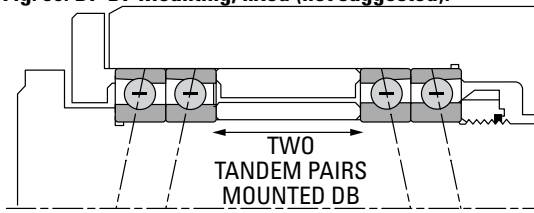

Fig. 91. DT-DB Mounting, fixed (suggested).

## SPRING-LOADED MOUNTINGS

For high-speed applications, radial and axial rigidity and smooth spindle performance may be obtained by spring-loading the ball bearings with a predetermined axial load. Spring-loading allows the spindle to float laterally during temperature changes without appreciably increasing or decreasing the original spring axial load.

As the inner ring heats up during operation, it expands radially. This radial expansion applies an increasing load through the ball and outer ring and finally to the preload springs. The preload springs deflect slightly to compensate for the loads due to thermal expansion and maintain a consistent load on the spindle system.

In some applications, single, spring-loaded bearings are employed at the front and rear locations, mounted in back-to-back arrangement. Other mountings, similarly spring-loaded, have a pair of bearings installed in tandem at each end of the spindle in back-to-back arrangement (DT-DB). In either case, the spring pressure is applied to the pulley-end or rear bearing position, placing the shaft in tension between the two bearing locations.

## HIGH POINTS OF RUNOUT

The correct use of the high point of runout etched on the bearing components allows the accuracy of the spindle to be optimized. The components should be mounted in the housing and on the spindle so that the high points are aligned with each other. In other words, the inner ring is fitted on the spindle so the high point of the rear ring is aligned with the high point of the nose bearing. Similarly, the high points of the outer ring are aligned in the housing.

To obtain maximum precision, and when the high points of runout of both the spindle and the housing are known, the respective high points of the bearing components should be 180 degrees opposite to those of the spindle and the housing. This will tend to neutralize the eccentricity and minimize the effect of the high spots of all components. The figures to the right show typical examples of the correct and incorrect use of the high point of runout of bearings.

The greatest accuracy can be provided by grinding the spindle nose after the bearings are installed. This procedure will produce spindle runout considerably smaller than the bearing runout.

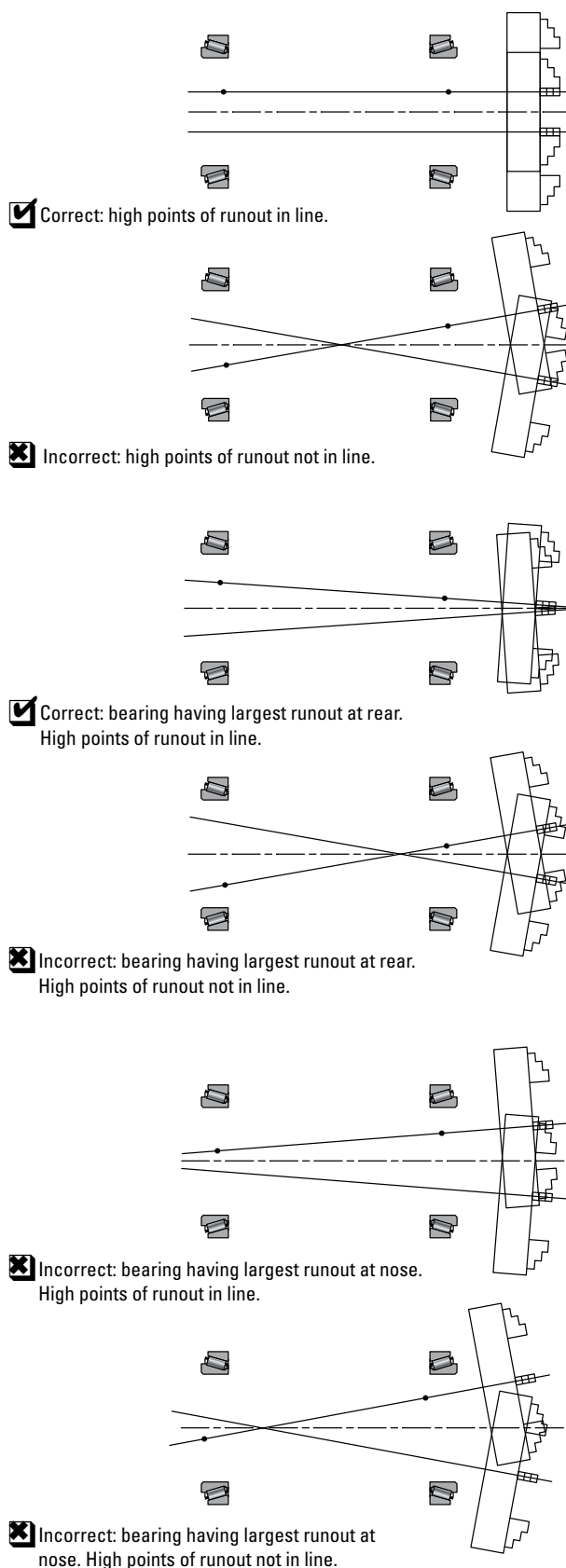

**Fig. 92. The effect of bearing runout high point locations on spindle accuracy.**



## SETTING AND PRELOADING GUIDELINES TAPERED ROLLER BEARINGS

The optimum operating setting of a bearing system has a direct influence on the spindle performance as far as accuracy, dynamic stiffness, operating temperature and cutting capabilities are concerned.

An operating setting range between zero and light preload is generally the optimum value for simple dual TS or TSF layouts.

To reach this range, it is important to evaluate the different parameters that will directly influence the operating setting in order to determine the cold-mounted setting:

- Rotating speed
- Applied loads
- Spindle layout
- Lubrication system
- External sources of heat

This evaluation occurs generally during the testing phase of the spindle because of the complexity of each individual parameter and the interaction of all of them during running conditions. At the same time, it also is important to consider the bearing layout and particularly the bearing spread to evaluate their effect on bearing setting.

It has been demonstrated that an optimum bearing spread for stiffness exists. In the same way, an optimum spread for thermal stability can be determined should this be the overriding factor.

Under steady-state temperature conditions, the spindle and housing temperature is not uniformly distributed. Generally, a temperature gradient of 2° C to 5° C (4° F to 9° F) exists between the spindle and housing. This phenomenon is valid for any type of bearing and has a direct influence on the bearing setting. In the case of pure radial bearings, such as cylindrical roller bearings, the radial setting will vary proportionally to the radial temperature gradient without any possibility for correction.

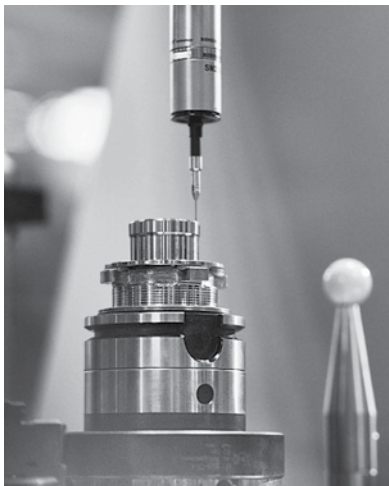

The use of tapered roller bearings allows the radial loss of end play due to the gradient between the spindle and the housing to be compensated by the axial expansion of the spindle with respect to the housing through optimization of the bearing spread.

Fig. 93 shows a graphical way to determine this optimum spread. To define the optimum spread for thermal compensation or to calculate the effect on setting for a given spread in a simple 2TS(F) bearing system, the designer can use the formula below for ferrous housings and spindles.

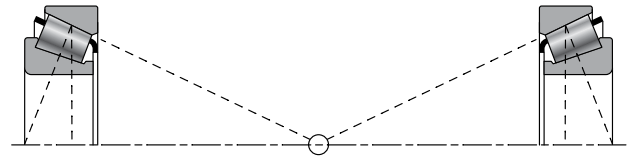

Fig. 93. Graphical determination of optimum thermal spread.

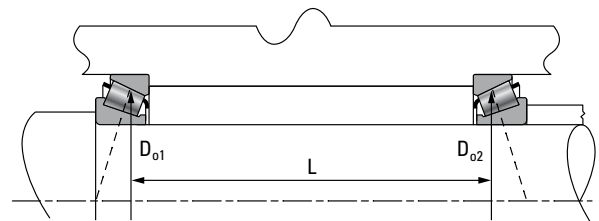

Fig. 94. Resulting distance between bearing geometric centerlines.

$$\text{Loss of end play} = 12 \times 10^{-6} \times t \times \left[ \left( \frac{K_1}{0.39} \times \frac{D_{o1}}{2} \right) + \left( \frac{K_2}{0.39} \times \frac{D_{o2}}{2} \right) - L \right]$$

Where:

t = temperature difference between shaft / inner ring rollers and housing / outer ring (  $\theta_s - \theta_h$  ) (°C)

K<sub>1</sub> and K<sub>2</sub> = respective K factor of bearings 1 and 2 from bearing tables

D<sub>o1</sub> and D<sub>o2</sub> = respective outer race mean diameter (mm)

L = distance between bearings geometric centerlines (mm)

During the starting period, care must be taken because the radial thermal expansion is not immediately compensated by the axial expansion of the spindle. That occurs later. During this “transient period,” a decrease of the axial end play or an increase of preload is generally recorded (Fig. 95). The loss of end play can be calculated by using the same formula, but ignoring the parameter “L.” For this reason, it is generally recommended to initially set the bearings with a light, cold end play to avoid any bearing burn-up, due to excessive

preload during the transient temperature rise. During the testing phase, it will be possible to modify this initial end play to obtain the optimum setting for the application.

Fig. 95 shows also that a three-support layout is more sensitive to thermal effects, leading to a higher temperature rise and loss of end play, than a simple arrangement because of the short bearing geometric spread at the fixed position.

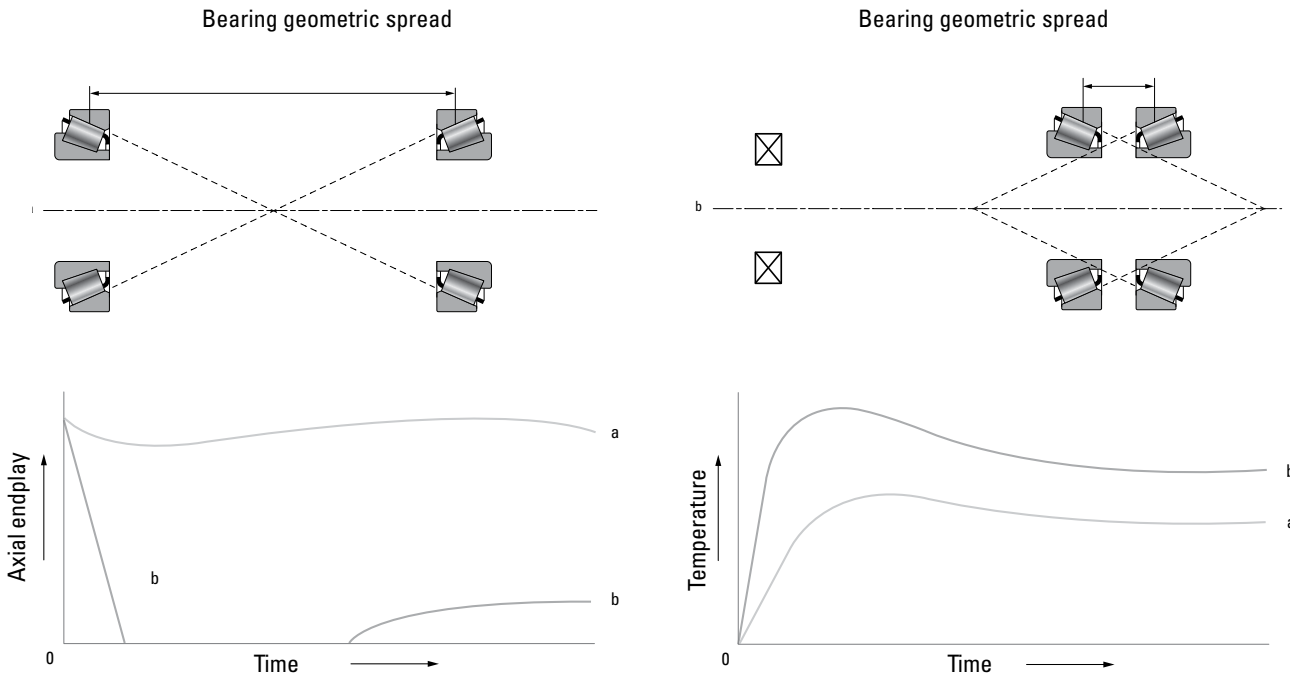

**Fig. 95. Evolution of the spindle system setting and temperature during the transient period:**  
**a) Simple mounting**  
**b) Three-support mounting.**

## BALL BEARINGS

Preloading of precision ball bearings to a predetermined axial load for “universal” mounting is accomplished by grinding a certain amount of stock off faces of the inner and outer rings so that before mounting the bearing, faces on the abutting side are offset an amount equal to the deflection under “preload.” When mounted, these faces are clamped together, the opposite bearing faces become flush and the bearing parts are subjected to compressive forces, bringing the balls into contact with their respective raceways to take up the initial clearances of the bearings. Thus, the preload built into the bearings is automatically obtained. The condition of a preloaded ball bearing is similar to that of one in operation under axial load. This initial axial load serves to decrease the axial and radial deflections when subsequent operational loads are imposed on the bearing assembly.

Bearings are preloaded no more than necessary. Excessive preload adds little to the rigidity of the spindle, but appreciably reduces the range of operating speeds by causing bearings to run hot at higher speeds. To meet conditions of speed, mounting arrangement and maximum rigidity consistent with low operating temperatures, Timken precision ball bearings are designed and produced with preloads varying from light to heavy and, in some instances, with negative preload.

In many cases, the amount of bearing preload is a trade-off between having the desired degree of rigidity and reducing any adverse effect preloading has on the equipment. If the operating speed is high, a heavy preload can lead to excessively high operating temperatures, resulting in shortened bearing life. For these reasons, three classes of ball bearing preloads are most commonly used – light, medium and heavy. In certain applications, such as high-speed motorized router spindles, specially preloaded, super precision ball bearings are required. Such bearings are “zero” preloaded – that is, the faces of the inner and outer rings are ground flush under negligible load.

The light, medium and heavy standard preload values for Timken super precision angular contact ball bearings and for both high and low contact angles are located with the dimension tables in Section C.

Axial deflection curves of various preload conditions for duplex pairs of 15 degree contact angle super precision ball bearings are shown in Fig. 96 and the radial deflection curves for the same bearings are shown in Fig. 97.

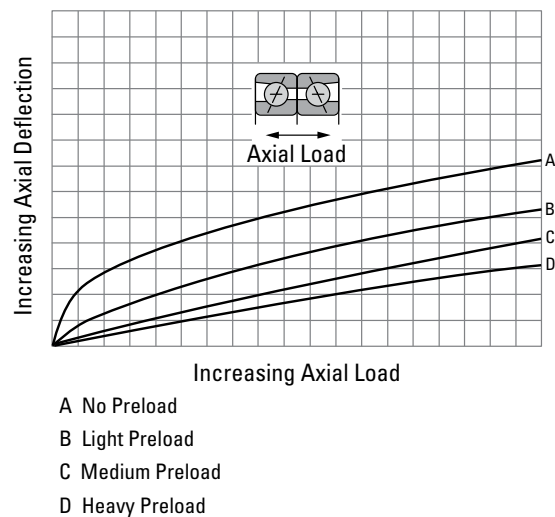

Fig. 96. Effect of most commonly used preloads on axial deflection.

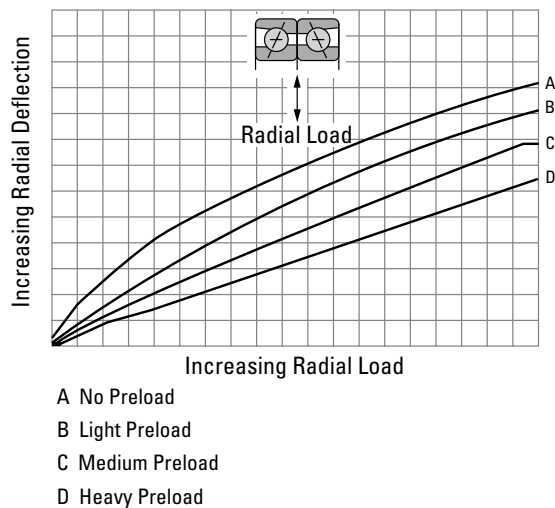
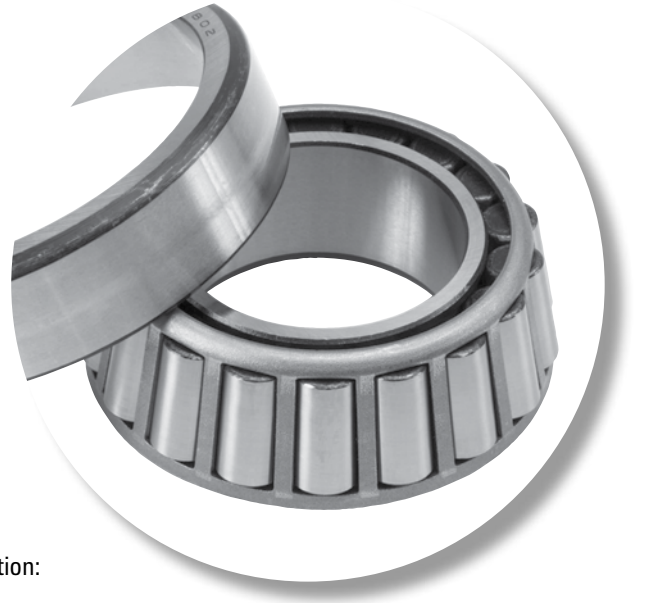

Fig. 97. Effect of most commonly used preloads on radial deflection.



***PRECISION TAPERED  
ROLLER BEARINGS***

The following topics are covered within this section:

Nomenclature .....	98
Introduction.....	102
Bearing Types .....	102
TS Style – Metric, Inch .....	104
TSF Style – Metric, Inch .....	108
TXR Style – Metric, Inch.....	112
TSHR Style – Metric, Inch .....	114
Tapered Roller Bearing Bore Diameters Found In This Catalog .....	118

This engineering section is not intended to be comprehensive, but does serve as a useful guide in bearing selection.

**NOMENCLATURE**

In order to provide our customers with clear and concise labeling, Timken has endeavored to keep things simple when creating references. The following should cover the majority of ordering

situations however, as always, your local Timken engineer will be pleased to provide further assistance if required.

**PRECISION TAPERED ROLLER BEARINGS  
TIMKEN SYSTEM**

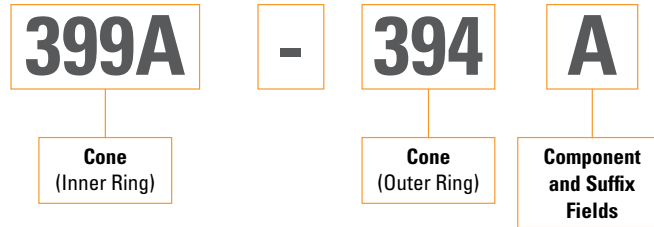

Fig 98. Precision tapered roller bearing nomenclature.

**PRECISION TAPERED ROLLER BEARINGS  
ISO 355 NUMBERING SYSTEM**

Cone Inner Ring

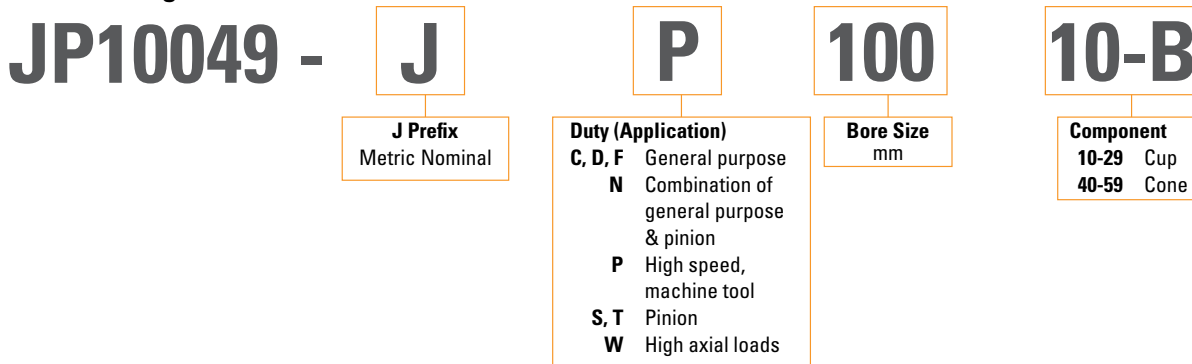

Fig 99. Precision tapered roller bearing ISO 355 nomenclature.

**PRECISION TAPERED ROLLER BEARINGS  
ABMA NUMBERING SYSTEM**

Cone Inner Ring

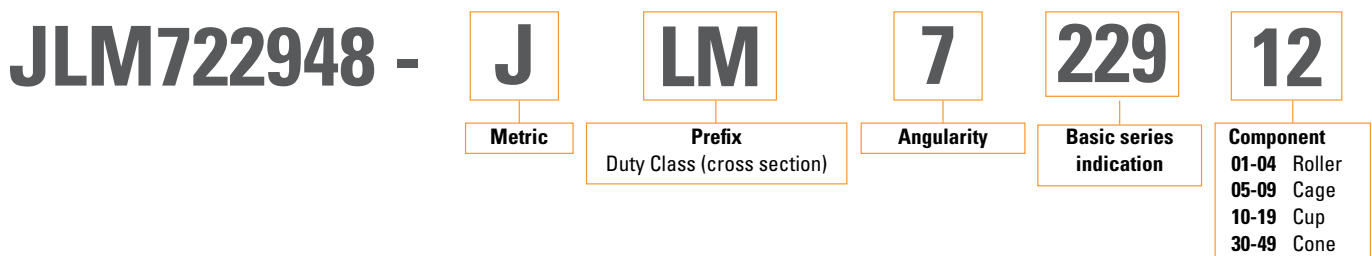

Fig 100. Precision tapered roller bearing ABMA nomenclature.

# TIMKEN PRECISION TAPERED ROLLER BEARINGS

The Timken bearing part numbering system has evolved over the years to accommodate various international standards put forth by both the ISO and ABMA organizations. To retain the integrity of Timken's proven initial designs and to support its extensive customer base, Timken recognizes the key numbering schemes as they have developed in the tapered roller bearing industry and as indicated here.

## ORIGINAL TIMKEN SYSTEM

(cone) - (cup)

**Ex: 399A-394A** (see common component/suffix)

- Family-design bearing group around a common roller (quantity and angle CAN vary).

**TABLE 68. UNIQUE COMPONENT PART NUMBERS.**

	Ex. I	Ex. II
Series	395	52000
Cup	399	52618
Cone	394	52387

- Numerical portion of part number has no significance in describing bearing size or type.

## ISO 355 NUMBERING SYSTEM

(application-oriented)

(cone) - (cup)

**Ex: JP100 49 - JP100 10-B**

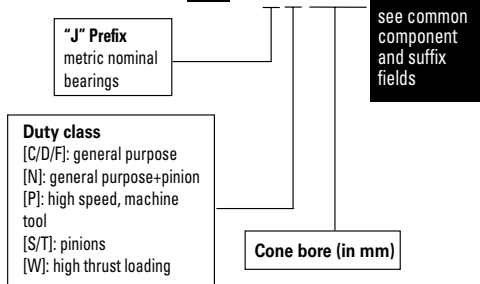

**TABLE 69. COMPONENT AND SUFFIX CODES**

Component Field (Final Two Digits Of Part Number)	
Series	00 (indicated by zeroes) Ex: 87000 or 36600
Cups	10 through 19 (thinnest cup section is #10)
Cones	30 through 49 (thinnest cone section is #49)
(Overflow numbers : 20 through 29 as needed; 50 through 99 as needed)	
Suffix Code Fields (One To Three Letters Max.)	
B:	Flanged cup
HR(A):	Hydra-Rib™ design (modified cup from standard)
P(H):	Customized for performance (non-interchangeable component)
E:	(Exclusive) non-interchangeable component

All components and variations in a given series are interchangeable.

## ABMA NUMBERING SYSTEM

(for inch and metric radial bearings)

**Ex: JLM7229 48 - JLM7229 12**

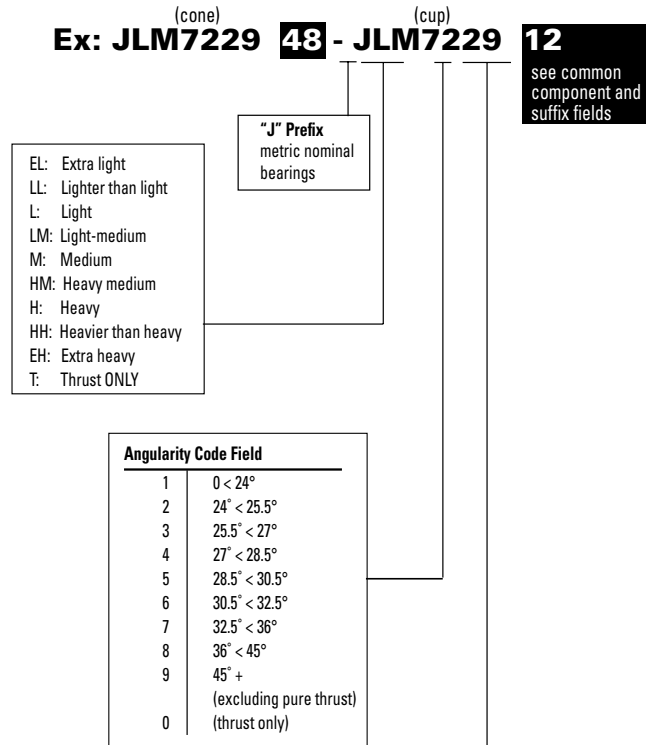

Angularity Code Field	
1	0 < 24°
2	24° < 25.5°
3	25.5° < 27°
4	27° < 28.5°
5	28.5° < 30.5°
6	30.5° < 32.5°
7	32.5° < 36°
8	36° < 45°
9	45° +
0	(excluding pure thrust) (thrust only)

Series Code Field		
(Cone bore) over/inl.		
in.	mm	Code
<1	<25.4	00 to 19
1-2	25.4-50.8	20 to 99;000 to 029
2-3	50.8-76.2	030 to 129
3-4	76.2-101.6	130 to 189
4-5	101.6-127.0	190 to 239
5-6	127.0-152.4	240 to 289
6-7	152.4-177.8	290 to 339
7-8	177.8-203.2	340 to 389
8-9	203.2-228.6	390 to 429
9-10	228.6-254.0	430 to 469
10-11	254.0-279.4	470 to 509
11-12	279.4-304.8	510 to 549
12-13	304.8-330.2	550 to 570
13-14	330.2-355.6	580 to 609
14-15	355.6-381.0	610 to 639
15-16	381.0-406.4	640 to 659
16-17	406.4-431.8	660 to 679
17-18	431.8-457.2	680 to 694
18-19	457.2-482.6	695 to 709
19-20	482.6-508.0	710 to 724
20-21	508.0-534.4	725 to 739
21-22	534.4-558.8	740 to 754
22-23	558.8-584.2	755 to 769
23-24	584.2-609.6	770 to 784
24-25	609.6-635.0	785 to 799
25-30	635.0-762.0	800 to 829
30-35	762.0-889.0	830 to 859
35-40	889.0-1016.0	860 to 879
40-50	1016.0-1270.0	880 to 889
50-72.5	1270.0-1841.0	890 to 899
>72.5	>1841.0	900 to 999

### ASSEMBLY CODES

- Five digit code:  
[Assy. No.]+[Timken code]+ [Bill of material code  
(first field is bearing precision class)]

Ex: **90B01** [Timken (internal) numbering system]

- Code is created at entry of initial custom order.
- For matched bearing assemblies: [cone PN]-[5-digit code]  
Ex: JP13049-90B01.
- For interchangeable components: [cone PN]-[cup PN]  
Ex: 29585-29520.

### INSPECTION CODES

- Five characters (as 3 fields).  
Component: [Precision class]+[Timken code]+[Performance code]

Ex: **C0030**

### IDENTIFICATION TAGS

See the following page for a detailed description of the use and purpose of component or assembly attached identification tags.

### BEARING PRECISION CLASS

- Indicated in inspection code.
- Each component is made to a precision class (tolerance and runout values are given in the Engineering Section).
- Tolerance structure differences within nominal inch and metric bearings.

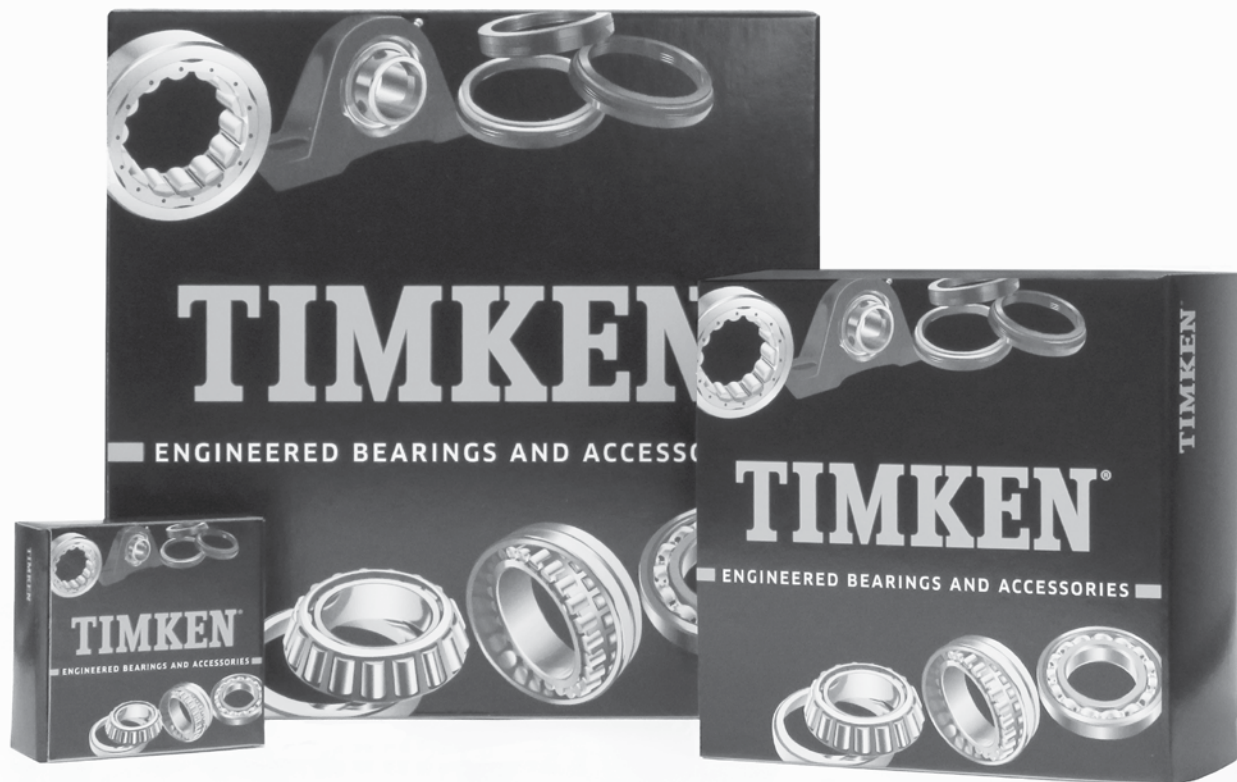



## TAG MARKINGS

Bearing tag markings are a device to indicate accuracy of bearings and facilitate selective assembly.

The information given on the tag varies by metric and inch systems, bearing class and type.

All components more precise than Class C or 3 cones and cups are supplied as matched assemblies and are shipped as complete bearings.

### 1. METRIC SYSTEM PRECISION BEARING TAG MARKINGS

Tags shown below are supplied with all Class A single-row matched assemblies. Class B cups and cones are tagged if indicated on the performance code.

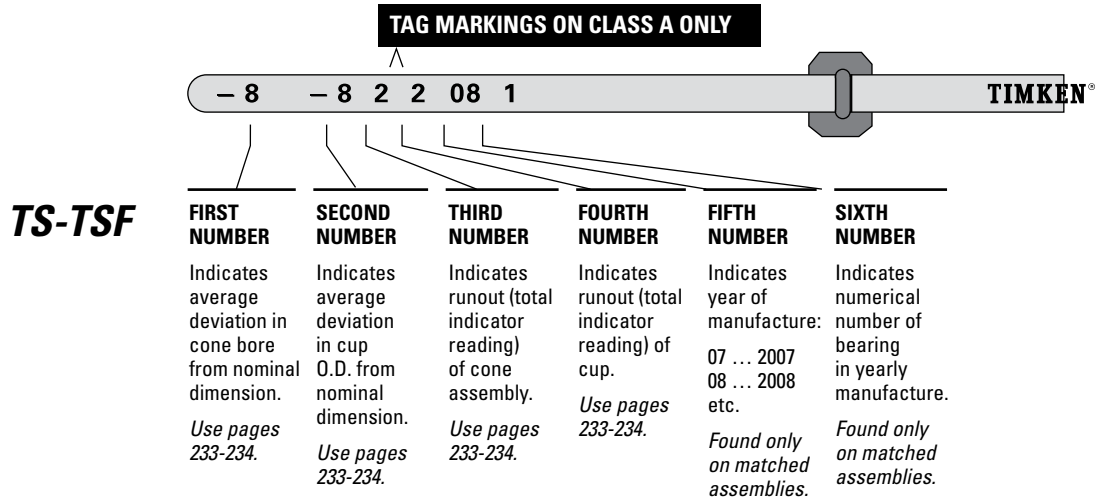

Fig. 101. Metric system precision bearing tag markings.

### 2. INCH SYSTEM PRECISION BEARING TAG MARKINGS

Tags shown below are supplied with all Class 00 cups and cones. Class 0 cups and cones are tagged if indicated on the performance code.

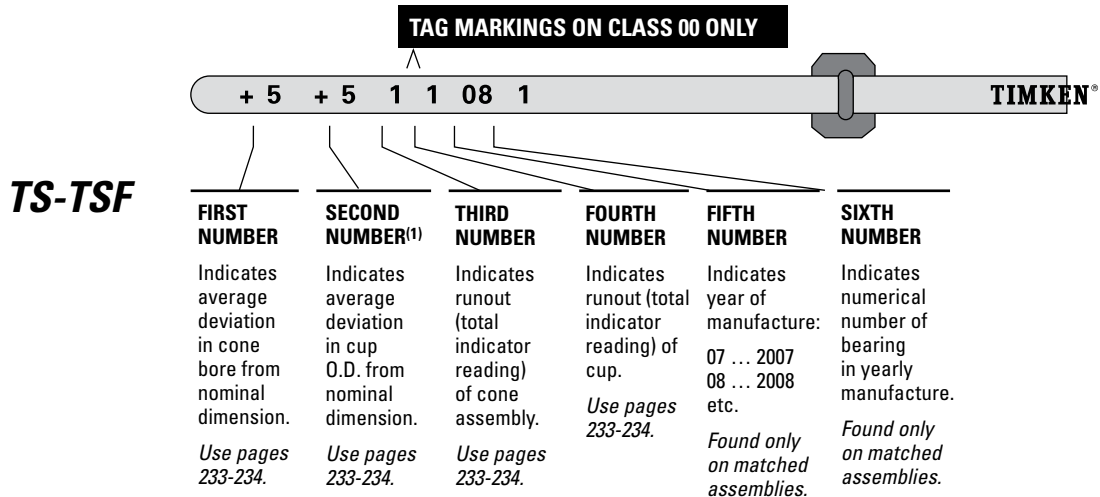

Fig. 102. Inch system precision bearing tag markings.

<sup>(1)</sup>Second number marked only on Class 3 product over 304.800 mm (12.0000 in.) cup O.D.

### INTRODUCTION

Timken® tapered roller bearings have been used for many years in machine tool applications due to their widely recognized advantages in stiffness, load-carrying capacity, precision and reliability over other bearing designs.

The use of new ceramic and CBN cutting tools, together with increased spindle motor powers, has allowed much higher cutting speeds to be achieved in many applications. To maintain the same global accuracy level at these higher cutting speeds poses a challenge to develop optimum spindle designs. Timken has met this challenge by developing:

- Special internal bearing geometry.
- Innovative bearing designs.

Technical information is provided in the Engineering Section of this catalog to assist the designer in selecting the right bearing arrangement for a given application.

Because of their high capability to carry loads together with a relatively low level of applied loads in the machine tool industry, precision tapered roller bearings are seldom replaced for fatigue damage. The bearings are mainly replaced when a global loss of precision of the machine is observed leading to a complete refurbishment of the machine. At this stage, it is advisable to replace the bearings, even if they may appear to be in good condition; they may be worn to a point where the accuracy is no longer effective.

### BEARING REPLACEMENT

Even if a machine is considered old after several years of service, it is not recommended to fit standard class bearings in place of the original precision ones. This practice would most likely result in uncontrolled movements of the spindle due to the higher runout of standard bearings. This can lead to poor accuracy of machined pieces and premature tool wear.

The best practice is to install a bearing of an equivalent precision class to the original equipment recommended by the builder.

Both inner and outer rings have to be replaced to achieve the same accuracy level as the original equipment.

### INSPECTION

The replacement of the bearings on any precision equipment is not necessarily sufficient to restore the original accuracy. If the surrounding components (spindle, housing, nut, spacer) show considerable defects in size or form, the bearing will simply transmit the consecutive default to the workpiece. The total runout of the system is the combination of the runout of each component. A precision bearing will add no more runout than is specified by the bearing class, but it will not reduce any runout already present from the spindle and housing.

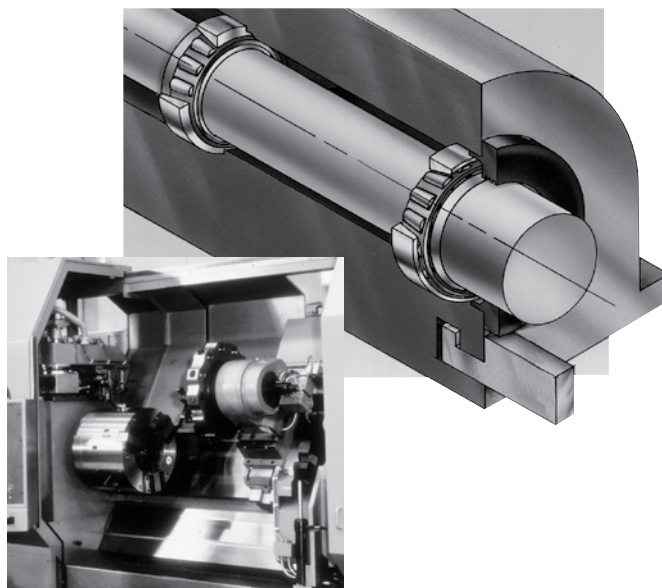

Careful inspection of the adjacent components followed by an appropriate refurbishment, if needed, must be made before remounting the bearings. Particular points to be checked are geometry (roundness, cylindricity, concentricity), surface conditions (nicks, burrs), sizes (bore, O.D. and width) and resultant fitting practice (see Engineering Section).

### REMOUNTING

The guidelines described in the Engineering Section apply exactly in the same way for replacement purposes as for original equipment.

### BEARING TYPES

The most popular tapered roller bearing types made in precision classes are the single-row bearings, types TS and TSF, and the two-row bearing, type TDO.

These bearing types are supported by a range of special bearings that have been designed for machine tool applications, such as the variable preload Hydra-Rib™ bearing, the high-speed TSMA bearing and the compact TXR crossed roller bearing, which are available only in precision classes.

The size range of Timken precision bearings starts from less than 20.000 mm (0.7874 in.) bore and extends to over 2000.000 mm (78.7402 in.) outside diameter, depending upon bearing type.

The importance of this market segment is demonstrated by Timken's commitment to having a plant dedicated to producing precision-class tapered roller bearings. This simply means that the precision quality is built into the bearing during manufacturing and is not achieved by selecting from standard bearings. For increased reliability, Timken bearings are manufactured from high-quality alloy steels.

The application of precision tapered roller bearings is not just limited to machine tools. Wherever spindles turn and rotational accuracy

is essential to the machine’s performance, precision tapered roller bearings are encountered. Other typical applications are printing presses, optical grinders, profile cutters, indexing tables, precision drives and measuring gauges.

## SINGLE-ROW BEARINGS

### TS – SINGLE ROW<sup>(1)</sup>

This is the basic and the most widely used type of tapered roller bearing. It consists of two main, separable parts: the inner ring (cone) assembly and the outer ring (cup). It is usually fitted as one of an opposing pair. During equipment assembly, single-row bearings can be “set” to the required clearance (endplay) or preload condition to optimize performance.



Fig. 103. TS single-row bearing.

### TSF – SINGLE-ROW, WITH FLANGED OUTER RING<sup>(1)</sup>

This variation on the basic single-row bearing, type TSF has a flanged outer ring to facilitate axial location and accurately aligned seats in a through-bored housing.



Fig. 104. TSF single-row bearing.

## TWO-ROW BEARINGS

### TDO – DOUBLE OUTER RACE

This has a one-piece (double) outer race and two single inner races and is usually supplied complete with an inner ring spacer as a pre-set assembly. This configuration gives a wide effective bearing spread and is frequently chosen for applications where overturning moments are a significant load component. TDO bearings can be used in fixed (locating) positions or allowed to float in the housing bore, for example, to compensate for shaft expansion.



Fig. 105. TDO two-row bearing.

### TXR – CROSSED ROLLER BEARING<sup>(1)</sup>

A crossed roller bearing is two sets of bearing races and rollers brought together at right angles – with alternate rollers facing opposite directions – within a section height not much greater than that of a single bearing. The steep angle, tapered geometry of the bearing causes the load-carrying center of each of the races to

be projected along the axis, resulting in a total effective bearing spread many times greater than the width of the bearing itself. This type of bearing offers a high resistance to overturning moments.

The normal design of the bearing is type TXRD0, which has a double outer race and two inner races, with rollers spaced by polymer separators.



Fig. 106. TXR crossed roller bearing.

## HIGH-SPEED BEARINGS

For many applications, notably in the machine tool industry, bearings are required to run at speeds in excess of those for which standard bearings are designed.

### TSMA – SINGLE-ROW, WITH AXIAL OIL HOLES

The TSMA type is a single-row bearing with axial oil holes for lubrication of the critical roller-rib contact area to ensure adequate lubrication at high speeds. The concept works by capturing oil in a manifold (attached to the inner ring), which is then directed to the rib-roller contact area through holes drilled axially through the large rib.



Fig. 107. TSMA single-row bearing with axial oil holes.

### TSHR – HYDRA-RIB BEARING WITH PRELOAD ADJUSTMENT DEVICE<sup>(1)</sup>

The Hydra-Rib bearing has a “floating” outer ring rib controlled by hydraulic or pneumatic pressure, which ensures that the required preload is maintained irrespective of the differential expansions or changes in loading taking place within the system.



Fig. 108. Hydra-Rib bearing with preload adjustment device.

The list of part numbers in the TS and TSF design styles tables is not exhaustive. These represent most of the common selections for the precision machine tool industry. Many tapered roller bearings currently are manufactured to “standard” precision classes (Class 3 or 0/ C or B) but can be readily produced to higher precision levels. Bearing modifications such as conversion to a two row design, a high speed TSMA, or use of ceramic rolling elements to meet specific application demands can usually be accommodated. Please contact your Timken representative for more information.

<sup>(1)</sup>These bearing types are described in detail in the bearing data tables at the end of this publication.

### TS STYLE

### PRECISION LEVEL C<sup>(1)</sup>

### DIMENSIONAL SIZES – METRIC

Features to enhance spindle operation:

- Matched components.
- Runout high points marked.
- Bearing setting adjustment.

Performance options:

- High-speed version (TSMA).

d Bore	D O.D.	T Width	Load Ratings				B Cone Width	C Cup Width	a Eff. Center <sup>(2)</sup>	Inner-Outer Part Number
			C <sub>0</sub> Static	C <sub>1</sub> Dynamic <sup>(3)</sup>	C <sub>90</sub> Dynamic <sup>(4)</sup>	C <sub>a90</sub> Dynamic <sup>(4)</sup>				
mm in.	mm in.	mm in.	kN lbs.	kN lbs.	kN lbs.	kN lbs.	mm in.	mm in.	mm in.	
60.000 2.3622	100.000 3.9370	21.000 0.8268	101.0 22700	80.9 18200	21.0 4720	17.0 3820	20.000 0.7874	15.500 0.6102	1.3 0.05	JP6049-JP6010
65.000 2.5591	105.000 4.1339	24.000 0.9449	139.0 31200	100.0 22500	26.0 5850	20.2 4540	23.000 0.9055	18.500 0.7283	-0.3 -0.01	JLM710949C-JLM710910
70.000 2.7559	110.000 4.3307	21.000 0.8268	112.0 25200	84.8 19100	22.0 4950	17.4 3910	20.000 0.7874	15.500 0.6102	2.5 0.10	JP7049-JP7010
80.000 3.1496	125.000 4.9213	24.000 0.9449	141.0 31700	105.0 23600	27.2 6120	21.0 4720	22.500 0.8858	17.500 0.6890	2.3 0.09	JP8049-JP8010
85.000 3.3465	130.000 5.1181	30.000 1.1811	245.0 55100	149.0 33500	38.7 8700	29.4 6610	29.000 1.1417	24.000 0.9449	-0.3 -0.01	JM716649-JM716610
90.000 3.5433	135.000 5.3150	24.000 0.9449	155.0 34800	110.0 24700	28.4 6390	24.0 5400	22.500 0.8858	17.500 0.6890	5.6 0.22	JP9049-JP9010
95.000 3.7402	145.000 5.7087	24.000 0.9449	172.0 38700	116.0 26100	30.1 6770	24.4 5490	22.500 0.8858	17.500 0.6890	6.1 0.24	JP10044-JP10010
95.000 3.7402	150.000 5.9055	35.000 1.3780	317.0 71300	199.0 44700	51.5 11600	39.0 8770	34.000 1.3386	27.000 1.0630	-1.5 -0.06	JM719149-JM719113
100.000 3.9370	145.000 5.7087	24.000 0.9449	172.0 38700	116.0 26100	30.1 6770	24.4 5490	22.500 0.8858	17.500 0.6890	6.1 0.24	JP10049-JP10010
110.000 4.3307	165.000 6.4961	35.000 1.3780	357.0 80300	210.0 47200	54.5 12300	46.4 10400	35.000 1.3780	26.500 1.0433	3.0 0.12	JM822049-JM822010
115.000 4.5276	165.000 6.4961	28.000 1.1024	245.0 55100	148.0 33300	38.3 8610	30.1 6770	27.000 1.0630	21.000 0.8268	5.6 0.22	JLM722948-JLM722912
120.000 4.7244	170.000 6.6929	25.400 1.0000	231.0 51900	134.0 30100	34.8 7820	27.3 6140	25.400 1.0000	19.050 0.7500	7.9 0.31	JL724348-JL724314
125.000 4.9213	175.000 6.8898	25.400 1.0000	246.0 55300	139.0 31200	36.0 8090	29.4 6610	25.400 1.0000	18.288 0.7200	9.1 0.36	JL725346-JL725316
130.000 5.1181	185.000 7.2835	29.000 1.1417	283.0 63600	181.0 40700	47.0 10600	38.1 8570	27.000 1.0630	21.000 0.8268	8.9 0.35	JP13049-JP13010
140.000 5.5118	195.000 7.6772	29.000 1.1417	304.0 68300	188.0 42300	48.8 11000	42.0 9440	27.000 1.0630	21.000 0.8268	11.9 0.47	JP14049-JP14010
150.000 5.9055	205.000 8.0709	28.575 1.1250	339.0 76200	179.0 40200	46.5 10500	36.5 8210	28.575 1.1250	21.438 0.8440	11.4 0.45	JL730646-JL730612
160.000 6.2992	220.000 8.6614	32.000 1.2598	372.0 83600	224.0 50400	58.1 13100	48.4 10900	30.000 1.1811	23.000 0.9055	13.0 0.51	JP16049-JP16010
170.000 6.6929	230.000 9.0551	32.000 1.2598	398.0 89500	232.0 52200	60.1 13500	47.5 10700	30.000 1.1811	23.000 0.9055	13.0 0.51	JP17049-JP17010
180.000 7.0866	240.000 9.4488	32.000 1.2598	490.0 91900	234.0 52600	60.6 13600	50.3 11300	30.000 1.1811	23.000 0.9055	16.0 0.63	JP18049-JP18010
180.000 7.0866	250.000 9.8425	47.000 1.8504	786.0 177000	401.0 90200	104.0 23400	85.5 19200	45.000 1.7717	37.000 1.4567	8.9 0.35	JM736149-JM736110

<sup>(1)</sup>Tighter tolerances are possible on any of the part numbers shown for higher precision requirements.

<sup>(2)</sup>Negative value indicates effective center within the backface of the cone.

<sup>(3)</sup>The Timken Company calculation based on one million revolutions for L<sub>10</sub> life.

<sup>(4)</sup>The Timken Company life calculations based on 90 million revolutions for L<sub>10</sub> life. C<sub>90</sub> is radial load component force; C<sub>a90</sub> is axial component.

<sup>(5)</sup>For synthetic high-speed grease in appropriate fill quantities with service interval and appropriate setting. Other methods may further improve speed by as much as 60 percent or more.

<sup>(6)</sup>For explanation of spindle system characteristics, please refer to pages 20-23 of the Engineering Section.

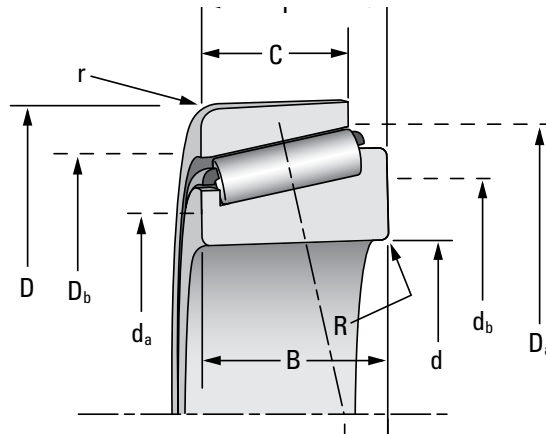

Mounting Dimensions						Stiffness <sup>(6)</sup>				Speed Rating <sup>(5)</sup>	Wt.
R Max. Shaft Fillet Rad. at Cone Backface	d <sub>a</sub>	d <sub>b</sub>	r	D <sub>a</sub>	D <sub>b</sub>	K <sub>r</sub> (10 <sup>6</sup> )	F <sub>r</sub>	K <sub>a</sub> (10 <sup>6</sup> )	F <sub>a</sub>		
mm in.	mm in.	mm in.	mm in.	mm in.	mm in.						
2.0 0.08	66.0 2.60	69.1 2.72	2.0 0.08	95.5 3.76	91.0 3.58	1.22 6.97	2.1 472	0.231 1.32	1.7 382	5100 5100	0.59 1.31
3.0 0.12	71.0 2.80	78.0 3.07	1.0 0.04	101.0 3.98	96.0 3.78	1.70 9.71	2.6 585	0.297 1.70	2.0 450	4800 4800	0.75 1.65
2.0 0.08	76.0 2.99	80.0 3.15	2.0 0.08	105.0 4.13	101.0 3.98	1.33 7.59	2.2 495	0.239 1.36	1.7 382	4500 4500	0.68 1.50
2.0 0.08	86.0 3.39	88.9 3.50	2.0 0.08	120.0 4.72	115.0 4.53	1.53 8.74	2.7 607	0.264 1.51	2.1 472	3900 3900	0.95 2.10
3.0 0.12	92.0 3.62	98.0 3.86	2.5 0.10	125.0 4.92	117.0 4.61	2.82 16.10	3.8 854	0.472 2.70	2.9 652	3700 3700	1.36 3.00
2.0 0.08	97.0 3.82	100.1 3.94	2.0 0.08	130.0 5.12	125.0 4.92	1.64 9.36	2.8 629	0.338 1.93	2.4 540	3600 3600	1.09 2.41
3.0 0.12	102.0 4.02	108.0 4.25	3.0 0.12	140.0 5.51	134.0 5.28	1.80 10.30	3.0 674	0.341 1.95	2.4 540	3300 3300	1.27 2.79
3.0 0.12	104.0 4.09	109.0 4.29	2.5 0.10	143.0 5.63	135.0 5.31	3.11 17.80	5.1 1150	0.513 2.93	3.9 877	3300 3300	2.17 4.78
3.0 0.12	106.0 4.17	112.0 4.41	3.0 0.12	140.0 5.51	134.0 5.28	1.80 10.30	3.0 674	0.341 1.95	2.4 540	3300 3300	1.13 2.49
3.0 0.12	119.0 4.69	125.0 4.92	2.5 0.10	159.0 6.26	149.0 5.87	3.39 19.40	5.4 1210	0.710 4.05	4.6 1030	2900 2900	2.45 5.39
3.3 0.13	121.0 4.76	127.0 5.00	3.0 0.12	158.0 6.22	151.0 5.94	2.53 14.40	3.8 854	0.450 2.57	3.0 674	2900 2900	1.75 3.86
3.3 0.13	127.0 5.00	132.1 5.20	3.3 0.13	163.0 6.42	156.0 6.14	2.47 14.10	3.5 787	0.440 2.51	2.7 607	2800 2800	1.62 3.56
3.3 0.13	133.0 5.24	137.9 5.43	3.3 0.13	168.0 6.61	161.0 6.34	2.60 14.90	3.6 809	0.499 2.85	2.9 652	2700 2700	1.69 3.72
3.0 0.12	137.0 5.39	143.0 5.63	3.0 0.12	179.0 7.05	172.0 6.77	2.45 14.00	4.7 1060	0.464 2.65	3.8 854	2600 2600	2.16 4.76
3.0 0.12	148.0 5.83	152.9 6.02	3.0 0.12	189.0 7.44	182.0 7.17	2.60 14.90	4.9 1100	0.556 3.17	4.2 944	2400 2400	2.29 5.06
3.3 0.13	158.0 6.22	164.1 6.46	3.3 0.13	198.0 7.8	190.0 7.48	3.30 18.80	4.6 1030	0.588 3.36	3.6 809	2200 2200	2.61 5.76
3.0 0.12	169.0 6.65	174.0 6.85	3.0 0.12	213.1 8.39	206.0 8.11	2.94 16.80	5.8 1300	0.589 3.36	4.8 1080	2100 2100	3.11 6.86
3.0 0.12	179.0 7.05	183.9 7.24	3.0 0.12	223.0 8.78	217.0 8.54	3.15 18.00	6.0 1350	0.568 3.24	4.7 1060	2000 2000	3.43 7.56
3.0 0.12	189.0 7.44	194.1 7.64	3.0 0.12	233.0 9.17	227.0 8.94	3.21 18.30	6.0 1350	0.638 3.64	5.0 1120	1900 1900	3.59 7.91
3.0 0.12	190.0 7.48	196.1 7.72	2.5 0.10	243.0 9.57	232.0 9.13	5.90 33.70	10.4 2340	1.150 6.57	8.5 1910	1800 1800	6.67 14.70

### TS STYLE

### PRECISION LEVEL 3<sup>(1)</sup>

### DIMENSIONAL SIZES – INCH

Features to enhance spindle operation:

- Matched components.
- Runout high points marked.
- Bearing setting adjustment.

Performance options:

- High-speed version (TSMA).

d Bore	D O.D.	T Width	Load Ratings				B Cone Width	C Cup Width	a Eff. Center <sup>(2)</sup>	Inner-Outer Part Number
			C <sub>0</sub> Static	C <sub>1</sub> Dynamic <sup>(3)</sup>	C <sub>90</sub> Dynamic <sup>(4)</sup>	C <sub>a90</sub> Dynamic <sup>(4)</sup>				
mm in.	mm in.	mm in.	kN lbs.	kN lbs.	kN lbs.	kN lbs.	mm in.	mm in.	mm in.	
<b>63.500</b> 2.5000	<b>107.950</b> 4.2500	<b>25.400</b> 1.0000	<b>158.0</b> 35500	<b>102.0</b> 22900	<b>26.5</b> 5950	<b>20.8</b> 4670	<b>25.400</b> 1.0000	<b>19.050</b> 0.7500	<b>-0.8</b> -0.03	29585-29520
<b>68.263</b> 2.6875	<b>110.000</b> 4.3307	<b>21.999</b> 0.8661	<b>126.0</b> 28300	<b>91.6</b> 20600	<b>23.8</b> 5340	<b>16.3</b> 3670	<b>21.996</b> 0.8660	<b>18.821</b> 0.7410	<b>-0.8</b> -0.03	399A-394A
<b>73.025</b> 2.8750	<b>112.713</b> 4.4375	<b>25.400</b> 1.0000	<b>166.0</b> 37300	<b>102.0</b> 23000	<b>26.5</b> 5960	<b>22.2</b> 4980	<b>25.400</b> 1.0000	<b>19.050</b> 0.7500	<b>1.0</b> 0.04	29685-29620
<b>76.200</b> 3.0000	<b>121.442</b> 4.7812	<b>24.608</b> 0.9688	<b>137.0</b> 30800	<b>94.7</b> 21300	<b>24.5</b> 5510	<b>18.9</b> 4260	<b>23.012</b> 0.9060	<b>17.625</b> 0.6875	<b>1.5</b> 0.06	34301-34478
<b>85.725</b> 3.3750	<b>136.525</b> 5.3750	<b>30.163</b> 1.1875	<b>216.0</b> 48500	<b>143.0</b> 32100	<b>37.1</b> 8330	<b>28.2</b> 6340	<b>29.769</b> 1.1720	<b>22.225</b> 0.8750	<b>-0.8</b> -0.03	497-493
<b>91.973</b> 3.6210	<b>142.875</b> 5.6250	<b>30.000</b> 1.1811	<b>240.0</b> 54000	<b>152.0</b> 34100	<b>39.3</b> 8830	<b>32.2</b> 7230	<b>30.000</b> 1.1811	<b>21.996</b> 0.8660	<b>1.8</b> 0.07	LM718947-LM718910
<b>101.600</b> 4.0000	<b>157.163</b> 6.1875	<b>36.513</b> 1.4375	<b>343.0</b> 77100	<b>207.0</b> 46500	<b>53.8</b> 12100	<b>43.6</b> 9800	<b>36.116</b> 1.4219	<b>26.187</b> 1.0310	<b>-0.5</b> -0.02	52400-52618
<b>117.475</b> 4.6250	<b>180.975</b> 7.1250	<b>34.925</b> 1.3750	<b>271.0</b> 60900	<b>181.0</b> 40700	<b>47.2</b> 10600	<b>39.9</b> 8980	<b>31.750</b> 1.2500	<b>25.400</b> 1.0000	<b>5.3</b> 0.21	68462-68712
<b>146.050</b> 5.7500	<b>193.675</b> 7.6250	<b>28.575</b> 1.1250	<b>407.0</b> 91500	<b>182.0</b> 40900	<b>47.2</b> 10600	<b>29.8</b> 6690	<b>28.575</b> 1.1250	<b>23.012</b> 0.9060	<b>4.8</b> 0.19	36690-36620
<b>177.800</b> 7.0000	<b>227.013</b> 8.9375	<b>30.163</b> 1.1875	<b>470.0</b> 105600	<b>194.0</b> 43500	<b>50.3</b> 11300	<b>37.9</b> 8510	<b>30.163</b> 1.1875	<b>23.012</b> 0.9060	<b>12.7</b> 0.50	36990-36920
<b>190.500</b> 7.5000	<b>282.575</b> 11.1250	<b>50.800</b> 2.0000	<b>690.0</b> 155100	<b>398.0</b> 89400	<b>103.0</b> 23200	<b>73.4</b> 16500	<b>47.625</b> 1.8750	<b>36.500</b> 1.4370	<b>3.8</b> 0.15	87750-87111
<b>206.375</b> 8.1250	<b>282.575</b> 11.1250	<b>46.038</b> 1.8125	<b>881.0</b> 198000	<b>393.0</b> 88300	<b>102.0</b> 22900	<b>88.5</b> 19900	<b>46.038</b> 1.8125	<b>36.500</b> 1.4370	<b>16.0</b> 0.63	67985-67920
<b>215.900</b> 8.5000	<b>290.010</b> 11.4177	<b>31.750</b> 1.2500	<b>457.0</b> 102700	<b>222.0</b> 49800	<b>57.4</b> 12900	<b>37.9</b> 8510	<b>31.750</b> 1.2500	<b>22.225</b> 0.8750	<b>13.0</b> 0.51	543085-543114

<sup>(1)</sup>Tighter tolerances are possible on any of the part numbers shown for higher precision requirements.

<sup>(2)</sup>Negative value indicates effective center within the backface of the cone.

<sup>(3)</sup>The Timken Company calculation based on one million revolutions for L<sub>10</sub> life.

<sup>(4)</sup>The Timken Company life calculations based on 90 million revolutions for L<sub>10</sub> life. C<sub>90</sub> is radial load component force; C<sub>a90</sub> is axial component.

<sup>(5)</sup>For synthetic high-speed grease in appropriate fill quantities with service interval and appropriate setting. Other methods may further improve speed by as much as 60 percent or more.

<sup>(6)</sup>For explanation of spindle system characteristics, please refer to pages 20-23 of the Engineering Section.



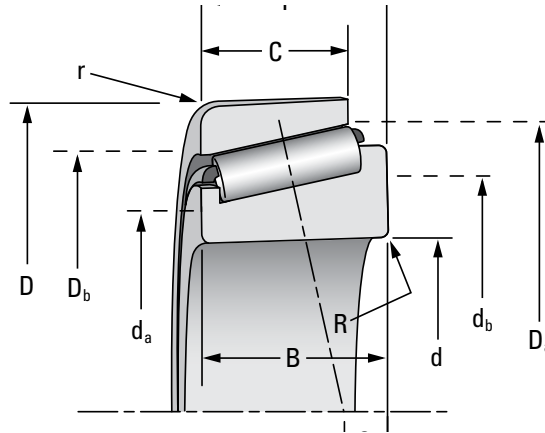

Mounting Dimensions						Stiffness <sup>(6)</sup>				Speed Rating <sup>(5)</sup>	Wt.
R Max. Shaft Fillet Rad. at Cone Backface	d <sub>a</sub>	d <sub>b</sub>	r	D <sub>a</sub>	D <sub>b</sub>	K <sub>r</sub> (10 <sup>6</sup> )	F <sub>r</sub>	K <sub>a</sub> (10 <sup>6</sup> )	F <sub>a</sub>		
mm in.	mm in.	mm in.	mm in.	mm in.	mm in.	N/mm lbs./in.	kN lbs.	N/mm lbs./in.	kN lbs.		
3.6 0.14	71.1 2.80	77.0 3.03	3.3 0.13	103.1 4.06	96.0 3.78	2.15 12.30	2.65 595	0.385 2.20	2.07 466	4500 4500	0.91 2.01
2.3 0.09	73.9 2.91	78.0 3.07	1.3 0.05	103.9 4.09	101.1 3.98	1.53 8.73	2.38 534	0.208 1.19	1.63 367	4600 4600	0.75 1.65
3.6 0.14	80.0 3.15	86.1 3.39	3.3 0.13	109.0 4.29	101.1 3.98	2.19 12.50	2.65 596	0.440 2.51	2.21 497	4200 4200	0.88 1.95
3.6 0.14	83.1 3.27	88.9 3.50	2.0 0.08	116.1 4.57	110.0 4.33	1.62 9.25	2.45 551	0.278 1.59	1.89 425	4100 4100	0.95 2.09
3.6 0.14	93.0 3.66	99.1 3.90	3.3 0.13	130.0 5.12	121.9 4.80	2.31 13.20	3.71 834	0.387 2.21	2.82 633	3700 3700	1.52 3.34
3.6 0.14	100.1 3.94	105.9 4.17	3.3 0.13	137.9 5.43	129.0 5.08	2.52 14.40	3.93 883	0.489 2.79	3.21 722	3400 3400	1.63 3.60
3.6 0.14	111.0 4.37	117.1 4.61	3.3 0.13	151.9 5.98	142.0 5.59	3.31 18.90	5.36 1206	0.630 3.60	4.35 979	3100 3100	2.39 5.28
3.6 0.14	125.0 4.92	132.1 5.20	3.3 0.13	172.0 6.77	163.1 6.42	2.31 13.20	4.69 1055	0.485 2.77	3.99 897	2800 2800	2.75 6.06
1.5 0.06	152.9 6.02	154.9 6.10	1.5 0.06	188.0 7.40	182.1 7.17	4.55 26.00	4.72 1060	0.524 2.99	2.97 667	2300 2300	2.25 4.96
1.5 0.06	185.9 7.32	188.0 7.40	1.5 0.06	221.0 8.70	214.1 8.43	5.13 29.30	5.02 1128	0.842 4.81	3.78 850	1900 1900	2.88 6.35
3.6 0.14	202.9 7.99	209.0 8.23	3.3 0.13	267.0 10.51	261.1 10.28	4.52 25.80	10.31 2318	0.660 3.77	7.32 1646	1700 1700	9.48 20.91
3.6 0.14	218.9 8.62	224.0 8.82	3.3 0.13	275.1 10.83	260.1 10.24	6.92 39.50	10.18 2288	1.520 8.68	8.86 1992	1600 1600	8.29 18.28
3.6 0.14	226.1 8.90	231.9 9.13	3.3 0.13	276.1 10.87	272.0 10.71	3.92 22.40	5.74 1291	0.494 2.82	3.78 850	1600 1600	5.41 11.92

### TSF STYLE

### PRECISION LEVEL C<sup>(1)</sup>

#### DIMENSIONAL SIZES – METRIC

- Flanged outer ring facilitates axial location.
- Features to enhance spindle operation:
  - Matched components.
  - Runout high points marked.
  - Bearing setting adjustment.

d Bore	D O.D.	T <sub>1</sub> Offset	Load Ratings				D <sub>1</sub> Flange Dia.	C <sub>2</sub> Flange Width	B Cone Width	C Cup Width	a Eff. Center <sup>(2)</sup>	Inner-Outer Part Number
			C <sub>0</sub> Static	C <sub>1</sub> Dynamic <sup>(3)</sup>	C <sub>90</sub> Dynamic <sup>(4)</sup>	C <sub>a90</sub> Dynamic <sup>(4)</sup>						
mm in.	mm in.	mm in.	kN lbs.	kN lbs.	kN lbs.	kN lbs.	mm in.	mm in.	mm in.	mm in.	mm in.	
<b>60.000</b> 2.3622	<b>100.000</b> 3.9370	<b>8.500</b> 0.3346	<b>101.0</b> 22700	<b>80.9</b> 18200	<b>21.0</b> 4720	<b>17.0</b> 3820	<b>105.0</b> 4.13	<b>3.0</b> 0.12	<b>20.000</b> 0.7874	<b>15.500</b> 0.6102	<b>1.3</b> 0.05	JP6049-JP6010-B
<b>70.000</b> 2.7559	<b>110.000</b> 4.3307	<b>8.500</b> 0.3346	<b>112.0</b> 25200	<b>84.8</b> 19100	<b>22.0</b> 4950	<b>17.4</b> 3910	<b>116.0</b> 4.57	<b>3.0</b> 0.12	<b>20.000</b> 0.7874	<b>15.500</b> 0.6102	<b>2.5</b> 0.10	JP7049-JP7010-B
<b>80.000</b> 3.1496	<b>125.000</b> 4.9213	<b>10.500</b> 0.4134	<b>141.0</b> 31700	<b>105.0</b> 23600	<b>27.2</b> 6120	<b>21.0</b> 4720	<b>132.0</b> 5.20	<b>4.0</b> 0.16	<b>22.500</b> 0.8858	<b>17.500</b> 0.6890	<b>2.3</b> 0.09	JP8049-JP8010-B
<b>90.000</b> 3.5433	<b>135.000</b> 5.3150	<b>10.500</b> 0.4134	<b>155.0</b> 34800	<b>110.0</b> 24700	<b>28.4</b> 6390	<b>24.0</b> 5400	<b>142.0</b> 5.60	<b>4.0</b> 0.16	<b>22.500</b> 0.8858	<b>17.500</b> 0.6890	<b>5.6</b> 0.22	JP9049-JP9010-B
<b>95.000</b> 3.7402	<b>145.000</b> 5.7087	<b>10.500</b> 0.4134	<b>172.0</b> 38700	<b>116.0</b> 26100	<b>30.1</b> 6770	<b>24.4</b> 5490	<b>152.0</b> 5.98	<b>4.0</b> 0.16	<b>22.500</b> 0.8858	<b>17.500</b> 0.6890	<b>6.1</b> 0.24	JP10044-JP10010-B
<b>100.000</b> 3.9370	<b>145.000</b> 5.7087	<b>10.500</b> 0.4134	<b>172.0</b> 38700	<b>116.0</b> 26100	<b>30.1</b> 6770	<b>24.4</b> 5490	<b>152.0</b> 5.98	<b>4.0</b> 0.16	<b>22.500</b> 0.8858	<b>17.500</b> 0.6890	<b>6.1</b> 0.24	JP10049-JP10010-B
<b>130.000</b> 5.1181	<b>185.000</b> 7.2835	<b>13.000</b> 0.5118	<b>283.0</b> 63600	<b>181.0</b> 40700	<b>47.0</b> 10600	<b>38.1</b> 8570	<b>192.0</b> 7.56	<b>5.0</b> 0.20	<b>27.000</b> 1.0630	<b>21.000</b> 0.8268	<b>8.9</b> 0.35	JP13049-JP13010-B
<b>140.000</b> 5.5118	<b>195.000</b> 7.6772	<b>13.000</b> 0.5118	<b>304.0</b> 68300	<b>188.0</b> 42300	<b>48.8</b> 11000	<b>42.0</b> 9440	<b>202.0</b> 7.95	<b>5.0</b> 0.20	<b>27.000</b> 1.0630	<b>21.000</b> 0.8268	<b>11.9</b> 0.47	JP14049-JP14010-B
<b>150.000</b> 5.9055	<b>205.000</b> 8.0709	<b>12.000</b> 0.4724	<b>339.0</b> 76200	<b>179.0</b> 40200	<b>46.5</b> 10500	<b>36.5</b> 8210	<b>210.0</b> 8.27	<b>4.86</b> 0.19	<b>28.575</b> 1.1250	<b>21.438</b> 0.8440	<b>11.4</b> 0.45	JL730646-JL730612-B

<sup>(1)</sup>Tighter tolerances are possible on any of the part numbers shown for higher precision requirements.

<sup>(2)</sup>Negative value indicates effective center within the backface of the cone.

<sup>(3)</sup>The Timken Company calculation based on one million revolutions for L<sub>10</sub> life.

<sup>(4)</sup>The Timken Company life calculations based on 90 million revolutions for L<sub>10</sub> life. C<sub>90</sub> is radial load component force; C<sub>a90</sub> is axial component.

<sup>(5)</sup>For synthetic high-speed grease in appropriate fill quantities with service interval and appropriate setting. Other methods may further improve speed by as much as 60 percent or more.

<sup>(6)</sup>For explanation of spindle system characteristics, please refer to pages 20-23 of the Engineering Section.



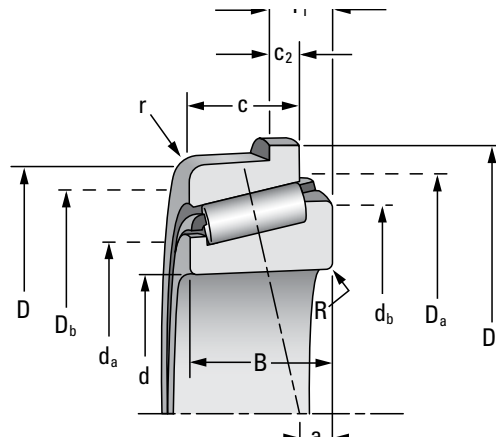

Mounting Dimensions						Stiffness <sup>(6)</sup>				Speed Rating <sup>(5)</sup>	Wt.
R Max. Shaft Fillet Rad. at Cone Backface	d <sub>a</sub>	d <sub>b</sub>	r Max. Housing Fillet Rad. at Cup Backface	D <sub>a</sub>	D <sub>b</sub>	K <sub>r</sub> (10 <sup>6</sup> )	F <sub>r</sub>	K <sub>a</sub> (10 <sup>6</sup> )	F <sub>a</sub>		
	Shaft Backing Diameter			Housing Backing Diameter						RPM	kg lbs.
mm in.	mm in.	mm in.	mm in.	mm in.	mm in.	N/mm lbs./in.	kN lbs.	N/mm lbs./in.	kN lbs.		
<b>2.0</b>	<b>66.0</b>	<b>69.0</b>	<b>2.0</b>	<b>98.0</b>	<b>91.0</b>	<b>1.22</b>	<b>2.1</b>	<b>0.231</b>	<b>1.7</b>	<b>5100</b>	<b>0.61</b>
0.08	2.60	2.72	0.08	3.86	3.58	6.97	472	1.32	382	5100	1.34
<b>2.0</b>	<b>76.0</b>	<b>80.0</b>	<b>2.0</b>	<b>105.5</b>	<b>101.0</b>	<b>1.33</b>	<b>2.2</b>	<b>0.239</b>	<b>1.7</b>	<b>4500</b>	<b>0.69</b>
0.08	2.99	3.15	0.08	4.15	3.98	7.59	495	1.36	382	4500	1.52
<b>2.0</b>	<b>86.0</b>	<b>89.0</b>	<b>2.0</b>	<b>129.0</b>	<b>115.0</b>	<b>1.53</b>	<b>2.7</b>	<b>0.264</b>	<b>2.1</b>	<b>3900</b>	<b>0.95</b>
0.08	3.39	3.50	0.08	5.08	4.53	8.74	607	1.51	472	3900	2.09
<b>2.0</b>	<b>97.0</b>	<b>100.0</b>	<b>2.0</b>	<b>133.0</b>	<b>125.0</b>	<b>1.64</b>	<b>2.8</b>	<b>0.338</b>	<b>2.4</b>	<b>3600</b>	<b>1.09</b>
0.08	3.82	3.94	0.08	5.24	4.92	9.36	629	1.93	540	3600	2.40
<b>3.0</b>	<b>102.0</b>	<b>108.0</b>	<b>3.0</b>	<b>142.0</b>	<b>134.0</b>	<b>1.80</b>	<b>3.0</b>	<b>0.341</b>	<b>2.4</b>	<b>3300</b>	<b>1.32</b>
0.12	4.02	4.25	0.12	5.59	5.28	10.28	674	1.95	540	3300	2.91
<b>3.0</b>	<b>106.0</b>	<b>112.0</b>	<b>3.0</b>	<b>142.0</b>	<b>134.0</b>	<b>1.80</b>	<b>3.0</b>	<b>0.341</b>	<b>2.4</b>	<b>3300</b>	<b>1.13</b>
0.12	4.17	4.41	0.12	5.59	5.28	10.28	674	1.95	540	3300	2.49
<b>3.0</b>	<b>137.0</b>	<b>143.0</b>	<b>3.0</b>	<b>188.0</b>	<b>172.0</b>	<b>2.45</b>	<b>4.7</b>	<b>0.464</b>	<b>3.8</b>	<b>2600</b>	<b>2.20</b>
0.12	5.39	5.63	0.12	7.40	6.77	13.99	1057	2.65	854	2600	4.85
<b>3.0</b>	<b>148.0</b>	<b>153.0</b>	<b>3.0</b>	<b>198.0</b>	<b>182.0</b>	<b>2.60</b>	<b>4.9</b>	<b>0.556</b>	<b>4.2</b>	<b>2400</b>	<b>2.31</b>
0.12	5.83	6.02	0.12	7.80	7.17	14.85	1102	3.17	944	2400	5.09
<b>3.3</b>	<b>158.0</b>	<b>164.0</b>	<b>3.3</b>	<b>200.0</b>	<b>190.0</b>	<b>3.30</b>	<b>4.6</b>	<b>0.588</b>	<b>3.6</b>	<b>2200</b>	<b>2.69</b>
0.13	6.22	6.46	0.13	7.87	7.48	18.84	1034	3.36	809	2200	5.93

### TSF STYLE PRECISION LEVEL 3<sup>(1)</sup> DIMENSIONAL SIZES – INCH

- Flanged outer ring facilitates axial location.
- Features to enhance spindle operation:
  - Matched components.
  - Runout high points marked.
  - Bearing setting adjustment.

d Bore	D O.D.	T <sub>1</sub> Offset	Load Ratings				D <sub>1</sub> Flange Dia.	C <sub>2</sub> Flange Width	B Cone Width	C Cup Width	a Eff. Center <sup>(2)</sup>	Inner-Outer Part Number
			C <sub>0</sub> Static	C <sub>1</sub> Dynamic <sup>(3)</sup>	C <sub>90</sub> Dynamic <sup>(4)</sup>	C <sub>a90</sub> Dynamic <sup>(4)</sup>						
mm in.	mm in.	mm in.	kN lbs.	kN lbs.	kN lbs.	kN lbs.	mm in.	mm in.	mm in.	mm in.	mm in.	
<b>46.038</b> 1.8125	<b>85.000</b> 3.3465	<b>9.525</b> 0.3750	<b>117.0</b> 26200	<b>86.4</b> 19400	<b>22.4</b> 5040	<b>13.3</b> 2980	<b>89.8</b> 3.53	<b>4.8</b> 0.19	<b>25.608</b> 1.0082	<b>20.638</b> 0.8125	<b>-6.4</b> -0.25	2984 - 2924-B
<b>66.675</b> 2.6250	<b>112.712</b> 4.4375	<b>11.112</b> 0.4375	<b>191.0</b> 43000	<b>129.0</b> 28900	<b>33.3</b> 7490	<b>22.9</b> 5160	<b>117.4</b> 4.62	<b>4.8</b> 0.19	<b>30.048</b> 1.1830	<b>23.812</b> 0.9375	<b>-4.6</b> -0.18	3984 - 3920-B
<b>69.850</b> 2.7500	<b>120.000</b> 4.7244	<b>11.095</b> 0.4368	<b>186.0</b> 41900	<b>133.0</b> 29900	<b>34.4</b> 7740	<b>22.7</b> 5100	<b>125.4</b> 4.94	<b>5.5</b> 0.22	<b>29.007</b> 1.1420	<b>24.237</b> 0.9542	<b>-4.1</b> -0.16	482 - 472-B
<b>69.850</b> 2.7500	<b>127.000</b> 5.0000	<b>14.288</b> 0.5625	<b>262.0</b> 58900	<b>182.0</b> 40900	<b>47.1</b> 10600	<b>29.4</b> 6600	<b>133.2</b> 5.25	<b>6.4</b> 0.25	<b>36.170</b> 1.4240	<b>28.575</b> 1.1250	<b>-8.1</b> -0.32	566 - 563-B
<b>73.025</b> 2.8750	<b>117.475</b> 4.6250	<b>11.112</b> 0.4375	<b>197.0</b> 44300	<b>128.0</b> 28800	<b>33.2</b> 7470	<b>24.8</b> 5570	<b>122.1</b> 4.81	<b>4.8</b> 0.19	<b>30.162</b> 1.1875	<b>23.812</b> 0.9375	<b>-2.8</b> -0.11	33287 - 33462-B
<b>83.345</b> 3.2813	<b>125.412</b> 4.9375	<b>10.317</b> 0.4062	<b>178.0</b> 39900	<b>109.0</b> 24400	<b>28.1</b> 6320	<b>20.0</b> 4500	<b>130.1</b> 5.12	<b>4.8</b> 0.19	<b>25.400</b> 1.0000	<b>19.845</b> 0.7813	<b>0.5</b> 0.02	27690 - 27620-B
<b>88.900</b> 3.5000	<b>149.225</b> 5.8750	<b>12.700</b> 0.5000	<b>241.0</b> 54300	<b>151.0</b> 33900	<b>39.1</b> 8790	<b>33.0</b> 7410	<b>154.7</b> 6.09	<b>5.6</b> 0.22	<b>28.971</b> 1.1406	<b>24.608</b> 0.9688	<b>3.0</b> 0.12	42350 - 42587-B
<b>95.250</b> 3.7500	<b>168.275</b> 6.6250	<b>18.255</b> 0.7187	<b>386.0</b> 86700	<b>245.0</b> 55100	<b>63.5</b> 14300	<b>51.2</b> 11500	<b>175.3</b> 6.90	<b>7.1</b> 0.28	<b>41.275</b> 1.6250	<b>30.162</b> 1.1875	<b>-2.8</b> -0.11	683 - 672-B
<b>101.600</b> 4.0000	<b>168.275</b> 6.6250	<b>18.255</b> 0.7187	<b>386.0</b> 86700	<b>245.0</b> 55100	<b>63.5</b> 14300	<b>51.2</b> 11500	<b>175.3</b> 6.90	<b>7.1</b> 0.28	<b>41.275</b> 1.6250	<b>30.162</b> 1.1875	<b>-2.8</b> -0.11	687 - 672-B
<b>114.300</b> 4.5000	<b>190.500</b> 7.5000	<b>20.638</b> 0.8125	<b>543.0</b> 122000	<b>337.0</b> 75700	<b>87.3</b> 19600	<b>62.2</b> 14000	<b>198.3</b> 7.81	<b>7.9</b> 0.31	<b>49.212</b> 1.9375	<b>34.925</b> 1.3750	<b>-6.6</b> -0.26	71450 - 71750-B

<sup>(1)</sup>Tighter tolerances are possible on any of the part numbers shown for higher precision requirements.

<sup>(2)</sup>Negative value indicates effective center within the backface of the cone.

<sup>(3)</sup>The Timken Company calculation based on one million revolutions for L<sub>10</sub> life.

<sup>(4)</sup>The Timken Company life calculations based on 90 million revolutions for L<sub>10</sub> life. C<sub>90</sub> is radial load component force; C<sub>a90</sub> is axial component.

<sup>(5)</sup>For synthetic high-speed grease in appropriate fill quantities with service interval and appropriate setting. Other methods may further improve speed by as much as 60 percent or more.

<sup>(6)</sup>For explanation of spindle system characteristics, please refer to pages 20-23 of the Engineering Section.

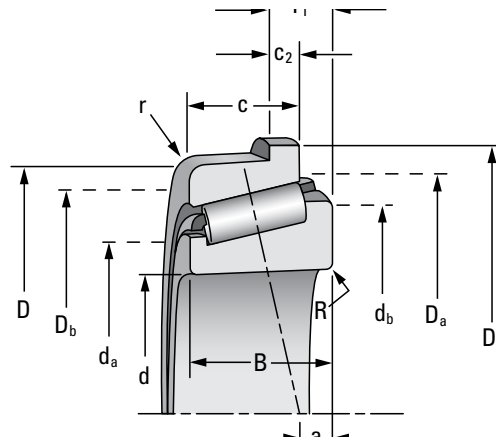

Mounting Dimensions						Stiffness <sup>(6)</sup>				Speed Rating <sup>(5)</sup>	Wt.
R Max. Shaft Fillet Rad. at Cone Backface	d <sub>a</sub>	d <sub>b</sub>	r	D <sub>a</sub>	D <sub>b</sub>	K <sub>r</sub> (10 <sup>6</sup> )	F <sub>r</sub>	K <sub>a</sub> (10 <sup>6</sup> )	F <sub>a</sub>		
mm in.	mm in.	mm in.	mm in.	mm in.	mm in.	N/mm lbs./in.	kN lbs.	N/mm lbs./in.	kN lbs.		
<b>3.5</b>	<b>52.0</b>	<b>58.0</b>	<b>1.3</b>	<b>82.0</b>	<b>76.0</b>	<b>1.68</b>	<b>2.2</b>	<b>0.170</b>	<b>1.3</b>	<b>6200</b>	<b>0.65</b>
0.14	2.05	2.28	0.05	3.23	2.99	9.60	504	0.97	298	6200	1.43
<b>3.5</b>	<b>74.0</b>	<b>80.0</b>	<b>3.3</b>	<b>108.0</b>	<b>99.0</b>	<b>2.33</b>	<b>3.3</b>	<b>0.318</b>	<b>2.3</b>	<b>4600</b>	<b>1.18</b>
0.14	2.91	3.15	0.13	4.25	3.90	13.30	749	1.82	516	4600	2.61
<b>3.5</b>	<b>77.0</b>	<b>83.0</b>	<b>0.8</b>	<b>115.0</b>	<b>108.0</b>	<b>2.08</b>	<b>3.4</b>	<b>0.261</b>	<b>2.3</b>	<b>4300</b>	<b>1.36</b>
0.14	3.03	3.27	0.03	4.53	4.25	11.90	774	1.49	510	4300	2.99
<b>3.5</b>	<b>78.0</b>	<b>85.0</b>	<b>3.3</b>	<b>121.0</b>	<b>112.0</b>	<b>2.71</b>	<b>4.7</b>	<b>0.303</b>	<b>2.9</b>	<b>4100</b>	<b>1.97</b>
0.14	3.07	3.35	0.13	4.76	4.41	15.50	1060	1.73	660	4100	4.34
<b>3.5</b>	<b>80.0</b>	<b>87.0</b>	<b>3.3</b>	<b>114.0</b>	<b>104.0</b>	<b>2.38</b>	<b>3.3</b>	<b>0.383</b>	<b>2.5</b>	<b>4300</b>	<b>1.25</b>
0.14	3.15	3.43	0.13	4.49	4.09	13.60	747	2.19	557	4300	2.75
<b>3.5</b>	<b>90.0</b>	<b>96.0</b>	<b>1.5</b>	<b>123.0</b>	<b>115.0</b>	<b>2.27</b>	<b>2.8</b>	<b>0.332</b>	<b>2.0</b>	<b>3800</b>	<b>1.08</b>
0.14	3.54	3.78	0.06	4.84	4.53	12.90	632	1.90	450	3800	2.37
<b>3.0</b>	<b>98.0</b>	<b>104.0</b>	<b>3.3</b>	<b>152.0</b>	<b>134.0</b>	<b>2.52</b>	<b>3.9</b>	<b>0.518</b>	<b>3.3</b>	<b>3300</b>	<b>2.13</b>
0.12	3.86	4.09	0.13	5.98	5.28	14.40	879	2.96	741	3300	4.70
<b>3.5</b>	<b>106.0</b>	<b>113.0</b>	<b>3.3</b>	<b>160.0</b>	<b>149.0</b>	<b>3.39</b>	<b>6.4</b>	<b>0.635</b>	<b>5.1</b>	<b>3000</b>	<b>3.79</b>
0.14	4.17	4.45	0.13	6.30	5.87	19.30	1430	3.62	1150	3000	8.36
<b>3.5</b>	<b>112.0</b>	<b>118.0</b>	<b>3.3</b>	<b>160.0</b>	<b>149.0</b>	<b>3.39</b>	<b>6.4</b>	<b>0.635</b>	<b>5.1</b>	<b>3000</b>	<b>3.47</b>
0.14	4.41	4.65	0.13	6.30	5.87	19.30	1430	3.62	1150	3000	7.66
<b>3.5</b>	<b>125.0</b>	<b>132.0</b>	<b>3.3</b>	<b>181.0</b>	<b>171.0</b>	<b>4.28</b>	<b>8.7</b>	<b>0.627</b>	<b>6.2</b>	<b>2700</b>	<b>5.31</b>
0.14	4.92	5.20	0.13	7.13	6.73	24.50	1960	3.58	1400	2700	11.70

**TXR STYLE**

**METRIC PRECISION LEVEL S,P**

**INCH PRECISION LEVEL 3.0**

**TIMKEN® CROSSED ROLLER BEARING**

- Compact design offers lowest possible center of gravity in precision rotational applications.
- Stability of bearing greatly enhanced by effective spread and high stiffness of double roller set.
- Ideal choice for table bearing for vertical machining operations.
- Provides low starting torque.
- Simplified construction facilitates installation and adjustments.
- Additional sizes and tolerances available upon special request.

**Precision Level S**

Config.	D O.D.	d Bore	T Width	R Radius	Load Ratings <sup>(4)</sup>		K <sup>(2)</sup>	Preload <sup>(5,3)</sup>	Part Number <sup>(6)</sup>
					Radial <sup>(1)</sup>	Axial			
	mm in.	mm in.	mm in.	mm in.	kN lbs.	kN lbs.		mm in.	
2	<b>400.000</b>	<b>300.000</b>	<b>37.000</b>	<b>1.5</b>	<b>63.0</b>	<b>80.1</b>	0.45	<b>0.025 to 0.040</b> 0.001 to 0.0015	JXR637050
	15.7480	11.8110	1.4567	0.06	14200	18000			
2	<b>425.000</b>	<b>310.000</b>	<b>45.000</b>	<b>2.5</b>	<b>82.2</b>	<b>102.0</b>	0.46	<b>0.025 to 0.040</b> 0.001 to 0.0015	JXR652050
	16.7323	12.2047	1.7717	0.10	18500	22900			
2	<b>495.000</b>	<b>370.000</b>	<b>50.000</b>	<b>3.0</b>	<b>93.6</b>	<b>119.0</b>	0.45	<b>0.040 to 0.050</b> 0.0015 to 0.002	JXR699050
	19.4882	14.5669	1.9685	0.12	21000	26800			

**Precision Level P**

2	<b>400.000</b>	<b>300.000</b>	<b>37.000</b>	<b>1.5</b>	<b>63.0</b>	<b>80.1</b>	0.45	<b>0.025 to 0.040</b> 0.001 to 0.0015	JXR637050
	15.7480	11.8110	1.4567	0.06	14200	18000			
2	<b>425.000</b>	<b>310.000</b>	<b>45.000</b>	<b>2.5</b>	<b>82.2</b>	<b>102.0</b>	0.46	<b>0.025 to 0.040</b> 0.001 to 0.0015	JXR652050
	16.7323	12.2047	1.7717	0.10	18500	22900			
2	<b>495.000</b>	<b>370.000</b>	<b>50.000</b>	<b>3.0</b>	<b>93.6</b>	<b>119.0</b>	0.45	<b>0.040 to 0.050</b> 0.0015 to 0.002	JXR699050
	19.4882	14.5669	1.9685	0.12	21000	26800			

<sup>(1)</sup>Tighter tolerances are possible on any of the part numbers shown for higher precision requirements.

<sup>(2)</sup>Negative value indicates effective center within the backface of the cone.

<sup>(3)</sup>The Timken Company calculation based on one million revolutions for L10 life.

<sup>(4)</sup>The Timken Company life calculations based on 90 million revolutions for L10 life. C90 is radial load component force; Ca90 is axial component.

<sup>(5)</sup>For synthetic high-speed grease in appropriate fill quantities with service interval and appropriate setting. Other methods may further improve speed by as much as 60 percent or more.

<sup>(6)</sup>For explanation of spindle system characteristics, please refer to pages 20-23 of the Engineering Section.

NOTE: Application of these preload values assumes suggested fitting practice in Engineering Section is used.

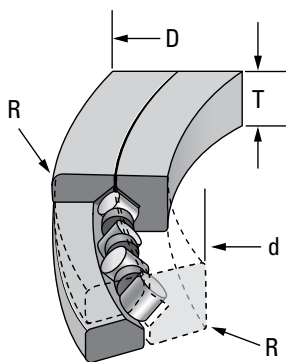

Config. 1

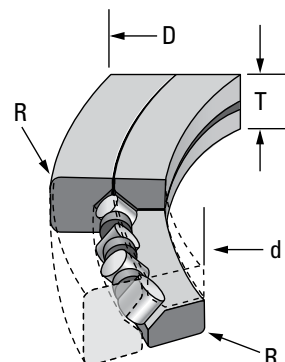

Config. 2

**Precision Level 3**

Config.	D O.D.	d Bore	T Width	R Radius	Load Ratings <sup>(4)</sup>		K <sup>(2)</sup>	Preload <sup>(5,3)</sup>	Part Number <sup>(6)</sup>
					Radial <sup>(1)</sup>	Axial			
					mm in.	mm in.			
2	<b>279.400</b>	<b>203.200</b>	<b>31.750</b>	<b>1.5</b>	<b>51.3</b>	<b>61.6</b>	0.48	<b>0.025 to 0.040</b>	XR496051
	11.0000	8.0000	1.2500	0.06	11500	13800			
2	<b>457.200</b>	<b>330.200</b>	<b>63.500</b>	<b>3.3</b>	<b>100.0</b>	<b>123.0</b>	0.47	<b>0.040 to 0.050</b>	XR678052
	18.0000	13.0000	2.5000	0.13	22500	27600			
2	<b>609.600</b>	<b>457.200</b>	<b>63.500</b>	<b>3.3</b>	<b>141.0</b>	<b>178.0</b>	0.45	<b>0.040 to 0.050</b>	XR766051
	24.0000	18.0000	2.5000	0.13	31600	40100			
2	<b>760.000</b>	<b>580.000</b>	<b>80.000</b>	<b>6.4</b>	<b>240.0</b>	<b>299.0</b>	0.46	<b>0.075 to 0.100</b>	XR820060
	29.9213	22.8346	3.1500	0.25	53900	67200			
2	<b>914.400</b>	<b>685.800</b>	<b>79.375</b>	<b>3.3</b>	<b>270.0</b>	<b>344.0</b>	0.45	<b>0.075 to 0.100</b>	XR855053
	36.0000	27.0000	3.1250	0.13	60700	77200			
2	<b>1117.600</b>	<b>901.700</b>	<b>82.550</b>	<b>3.3</b>	<b>300.0</b>	<b>396.0</b>	0.44	<b>0.100 to 0.150</b>	XR882055
	44.0000	35.5000	3.2500	0.13	67400	88900			
2	<b>1327.150</b>	<b>1028.700</b>	<b>114.300</b>	<b>3.3</b>	<b>405.0</b>	<b>534.0</b>	0.44	<b>0.125 to 0.180</b>	XR889058
	52.2500	40.5000	4.5000	0.13	91000	120000			
2	<b>1828.800</b>	<b>1549.400</b>	<b>101.600</b>	<b>3.3</b>	<b>518.0</b>	<b>699.0</b>	0.43	<b>0.150 to 0.200</b>	XR897051
	72.0000	61.0000	4.0000	0.13	116000	157000			

**Precision Level 0**

2	<b>279.400</b>	<b>203.200</b>	<b>31.750</b>	<b>1.5</b>	<b>51.3</b>	<b>61.6</b>	0.48	<b>0.025 to 0.040</b>	XR496051
	11.0000	8.0000	1.2500	0.06	11500	13800			
2	<b>457.200</b>	<b>330.200</b>	<b>63.500</b>	<b>3.3</b>	<b>100.0</b>	<b>123.0</b>	0.47	<b>0.040 to 0.050</b>	XR678052
	18.0000	13.0000	2.5000	0.13	22500	27600			
2	<b>609.600</b>	<b>457.200</b>	<b>63.500</b>	<b>3.3</b>	<b>141.0</b>	<b>178.0</b>	0.45	<b>0.040 to 0.050</b>	XR766051
	24.0000	18.0000	2.5000	0.13	31600	40100			

**TSHR STYLE**  
**HYDRA-RIB™ AND SPRING-RIB™**  
**TIMKEN® HYDRA-RIB BEARING**

- Precision metric bearing available in any precision class.
- Floating outer ring rib maintains preload using fluid pressure.
- Unique design allows for thermal expansion of spindle while maintaining desired preload.
- Ideal choice for floating position bearing set.
- Only minor modifications needed on existing spindles to install.
- Speed ratings for Hydra-Rib and Spring-Rib bearings are significantly higher than standard ribbed-cone designs. Consult the Engineering Section for greater detail, or contact your Timken representative.]

**TIMKEN® SPRING-RIB BEARING**  
*(NOT INCLUDED IN CHART BELOW)*

- Bearing preload maintained using spring pressure.
- Available in JP5000, JP8500, JP11000 and JP17000 series.
- Ideal choice for applications with relatively constant load and speed.
- Choices of light, medium or heavy preload settings (medium is standard).
- Call for available sizes.

d Bore	D <sub>1</sub> Flange Dia.	D Seat Dia.	T <sub>1</sub> Width	C <sub>90</sub> Load Ratings <sup>(2)</sup>	C Cup Width	C <sub>1</sub> Seat Width	a Eff. Center <sup>(1)</sup>
mm in.	mm in.	mm in.	mm in.	kN lbs.	mm in.	mm in.	mm in.
<b>50.000</b> 1.9685	<b>103.175</b> 4.0620	<b>104.000</b> 4.0945	<b>31.000</b> 1.2205	<b>20.6</b> 4630	<b>66.000</b> 2.5984	<b>15.000</b> 0.5906	<b>-13.0</b> -0.51
<b>50.000</b> 1.9685	<b>103.175</b> 4.0620	<b>104.000</b> 4.0945	<b>31.000</b> 1.2205	<b>20.6</b> 4630	<b>66.000</b> 2.5984	<b>15.000</b> 0.5906	<b>-13.0</b> -0.51
<b>50.000</b> 1.9685	<b>103.500</b> 4.0748	<b>104.000</b> 4.0945	<b>31.000</b> 1.2205	<b>20.6</b> 4630	<b>66.000</b> 2.5984	<b>15.000</b> 0.5906	<b>-13.0</b> -0.51
<b>50.000</b> 1.9685	<b>103.175</b> 4.0620	<b>104.000</b> 4.0945	<b>31.000</b> 1.2205	<b>20.6</b> 4630	<b>66.000</b> 2.5984	<b>15.000</b> 0.5906	<b>-13.0</b> -0.51
<b>75.000</b> 2.9528	<b>130.000</b> 5.1181	<b>122.000</b> 4.8031	<b>22.000</b> 0.8661	<b>23.1</b> 5190	<b>65.000</b> 2.5591	<b>10.000</b> 0.3937	<b>-10.2</b> -0.40
<b>75.000</b> 2.9528	<b>130.000</b> 5.1181	<b>122.000</b> 4.8031	<b>22.000</b> 0.8661	<b>23.1</b> 5190	<b>65.000</b> 2.5591	<b>10.000</b> 0.3937	<b>-10.2</b> -0.40
<b>85.000</b> 3.3465	<b>148.000</b> 5.8268	<b>140.000</b> 5.5118	<b>23.500</b> 0.9252	<b>30.1</b> 6760	<b>66.000</b> 2.5984	<b>10.000</b> 0.3937	<b>-9.1</b> -0.36
<b>85.000</b> 3.3465	<b>148.000</b> 5.8268	<b>140.000</b> 5.5118	<b>23.500</b> 0.9252	<b>30.1</b> 6760	<b>66.000</b> 2.5984	<b>10.000</b> 0.3937	<b>-9.1</b> -0.36
<b>95.000</b> 3.7402	<b>158.000</b> 6.2205	<b>145.000</b> 5.7087	<b>21.000</b> 0.8268	<b>29.5</b> 6640	<b>70.000</b> 2.7559	<b>10.000</b> 0.3937	<b>4.3</b> 0.17
<b>95.000</b> 3.7402	<b>158.000</b> 6.2205	<b>145.000</b> 5.7087	<b>21.000</b> 0.8268	<b>29.5</b> 6640	<b>70.000</b> 2.7559	<b>10.000</b> 0.3937	<b>4.3</b> 0.17
<b>100.000</b> 3.9370	<b>178.000</b> 7.0079	<b>170.000</b> 6.6929	<b>27.000</b> 1.0630	<b>34.1</b> 7660	<b>70.000</b> 2.7559	<b>12.000</b> 0.4724	<b>10.4</b> 0.41
<b>110.000</b> 4.3307	<b>178.000</b> 7.0079	<b>170.000</b> 6.6929	<b>27.000</b> 1.0630	<b>34.1</b> 7660	<b>70.000</b> 2.7559	<b>12.000</b> 0.4724	<b>10.4</b> 0.41
<b>115.000</b> 4.5276	<b>190.000</b> 7.4803	<b>180.000</b> 7.0866	<b>26.000</b> 1.0236	<b>42.0</b> 9440	<b>70.000</b> 2.7559	<b>12.000</b> 0.4724	<b>-7.1</b> -0.28
<b>120.000</b> 4.7244	<b>190.000</b> 7.4803	<b>180.000</b> 7.0866	<b>26.000</b> 1.0236	<b>42.0</b> 9440	<b>70.000</b> 2.7559	<b>12.000</b> 0.4724	<b>-7.1</b> -0.28

<sup>(1)</sup>Negative value indicates effective center within the width of the inner ring.  
<sup>(2)</sup>The Timken Company life calculations based on 90 million revolutions for L10 life.

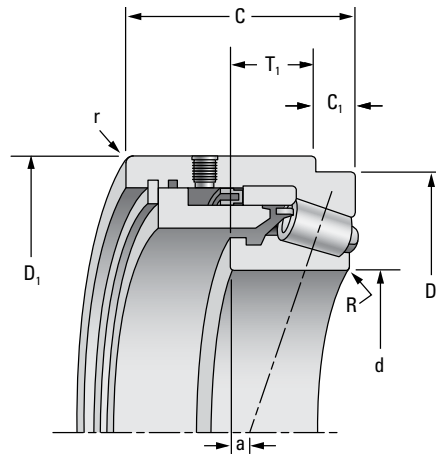

Hydra-Rib Part Number	Mounting Dimensions			Stiffness			
	R Shaft Radius	Shaft Shoulder Dia.	r Housing Radius	K <sub>r</sub> (10 <sup>6</sup> )	F <sub>r</sub>	K <sub>a</sub> (10 <sup>6</sup> )	F <sub>a</sub>
	mm in.	mm in.	mm in.	N/mm lbs./in.	kN lbs.	N/mm lbs./in.	kN lbs.
JP5049PH-JP5017HR	<b>3.0</b>	<b>61.0</b>	<b>1.0</b>	<b>1.18</b>	<b>2.06</b>	<b>0.126</b>	<b>1.25</b>
	0.12	2.40	0.04	6.77	463	0.721	282
JP5049PH-JP5020HR	<b>3.0</b>	<b>61.0</b>	<b>1.0</b>	<b>1.18</b>	<b>2.06</b>	<b>0.126</b>	<b>1.25</b>
	0.12	2.40	0.04	6.77	463	0.721	282
JP5049P-JP5019HR	<b>3.0</b>	<b>61.0</b>	<b>1.0</b>	<b>1.18</b>	<b>2.06</b>	<b>0.126</b>	<b>1.25</b>
	0.12	2.40	0.04	6.77	463	0.721	282
JP5049P-JP5020HR	<b>3.0</b>	<b>61.0</b>	<b>1.0</b>	<b>1.18</b>	<b>2.06</b>	<b>0.126</b>	<b>1.25</b>
	0.12	2.40	0.04	6.77	463	0.721	282
JP7548P-JP7520HR	<b>3.0</b>	<b>85.0</b>	<b>2.0</b>	<b>1.43</b>	<b>2.31</b>	<b>0.177</b>	<b>1.52</b>
	0.12	3.35	0.08	8.14	519	1.01	341
JP7549P-JP7519HR	<b>3.0</b>	<b>85.0</b>	<b>2.0</b>	<b>1.43</b>	<b>2.31</b>	<b>0.177</b>	<b>1.52</b>
	0.12	3.35	0.08	8.14	519	1.01	341
JP8548-JP8518HR	<b>3.0</b>	<b>96.0</b>	<b>2.0</b>	<b>1.77</b>	<b>3.01</b>	<b>0.212</b>	<b>1.93</b>
	0.12	3.78	0.08	10.1	676	1.21	435
JP8549P-JP8519HR	<b>3.0</b>	<b>96.0</b>	<b>2.0</b>	<b>1.77</b>	<b>3.01</b>	<b>0.212</b>	<b>1.93</b>
	0.12	3.78	0.08	10.1	676	1.21	435
JP10048-JP10019HR	<b>3.0</b>	<b>107.0</b>	<b>1.5</b>	<b>1.76</b>	<b>2.95</b>	<b>0.222</b>	<b>1.95</b>
	0.12	4.21	0.06	10.0	664	1.27	439
JP10048-JP10019HRA	<b>3.0</b>	<b>107.0</b>	<b>1.5</b>	<b>1.76</b>	<b>2.95</b>	<b>0.222</b>	<b>1.95</b>
	0.12	4.21	0.06	10.0	664	1.27	439
JP11035-JP11019HR	<b>3.0</b>	<b>114.0</b>	<b>1.0</b>	<b>2.05</b>	<b>3.41</b>	<b>0.224</b>	<b>2.10</b>
	0.12	4.49	0.04	11.7	766	1.28	471
JP11048-JP11019HR	<b>3.0</b>	<b>122.0</b>	<b>1.0</b>	<b>2.05</b>	<b>3.41</b>	<b>0.224</b>	<b>2.10</b>
	0.12	4.80	0.04	11.7	766	1.28	471
JP12043P-JP12019HR	<b>3.0</b>	<b>128.0</b>	<b>1.0</b>	<b>2.41</b>	<b>4.20</b>	<b>0.310</b>	<b>2.80</b>
	0.12	5.04	0.04	13.8	944	1.77	630
JP12049P-JP12019HR	<b>3.0</b>	<b>132.0</b>	<b>1.0</b>	<b>2.41</b>	<b>4.20</b>	<b>0.310</b>	<b>2.80</b>
	0.12	5.20	0.04	13.8	944	1.77	630

Continued on next page.

### HYDRA-RIB AND SPRING-RIB

#### TIMKEN HYDRA-RIB BEARING

- Precision metric bearing available in any precision class.
- Floating outer ring rib maintains preload using fluid pressure.
- Unique design allows for thermal expansion of spindle while maintaining desired preload.
- Ideal choice for floating position bearing set.
- Only minor modifications needed on existing spindles to install.
- Speed ratings for Hydra-Rib and Spring-Rib bearings are significantly higher than standard ribbed-cone designs. Consult the Engineering Section for greater detail, or contact your Timken representative.]

#### TIMKEN SPRING-RIB BEARING

(NOT INCLUDED IN CHART BELOW)

- Bearing preload maintained using spring pressure.
- Available in JP5000, JP8500, JP11000 and JP17000 series.
- Ideal choice for applications with relatively constant load and speed.
- Choices of light, medium or heavy preload settings (medium is standard).
- Call for available sizes.

d Bore	D <sub>1</sub> Flange Dia.	D Seat Dia.	T <sub>1</sub> Width	C <sub>90</sub> Load Ratings <sup>(2)</sup>	C Cup Width	C <sub>1</sub> Seat Width	a Eff. Center <sup>(1)</sup>
mm in.	mm in.	mm in.	mm in.	kN lbs.	mm in.	mm in.	mm in.
<b>125.000</b> 4.9213	<b>200.000</b> 7.8740	<b>190.000</b> 7.4803	<b>29.000</b> 1.1417	<b>49.9</b> 11200	<b>72.000</b> 2.8346	<b>12.000</b> 0.4724	<b>-7.6</b> -0.30
<b>130.000</b> 5.1181	<b>200.000</b> 7.8740	<b>190.000</b> 7.4803	<b>29.000</b> 1.1417	<b>49.9</b> 11200	<b>72.000</b> 2.8346	<b>12.000</b> 0.4724	<b>-7.6</b> -0.30
<b>135.000</b> 5.3150	<b>213.000</b> 8.3858	<b>205.000</b> 8.0709	<b>27.000</b> 1.0630	<b>50.6</b> 11400	<b>72.000</b> 2.8346	<b>13.000</b> 0.5118	<b>-15.8</b> -0.62
<b>140.000</b> 5.5118	<b>213.000</b> 8.3858	<b>205.000</b> 8.0709	<b>27.000</b> 1.0630	<b>50.6</b> 11400	<b>72.000</b> 2.8346	<b>13.000</b> 0.5118	<b>-3.8</b> -0.15
<b>155.000</b> 6.1024	<b>235.000</b> 9.2520	<b>227.000</b> 8.9370	<b>30.000</b> 1.1811	<b>60.9</b> 13700	<b>76.000</b> 2.9921	<b>15.000</b> 0.5906	<b>-5.1</b> -0.20
<b>160.000</b> 6.2992	<b>235.000</b> 9.2520	<b>227.000</b> 8.9370	<b>30.000</b> 1.1811	<b>60.9</b> 13700	<b>79.000</b> 3.1102	<b>15.000</b> 0.5906	<b>-5.1</b> -0.20
<b>170.000</b> 6.6929	<b>248.000</b> 9.7638	<b>240.000</b> 9.4488	<b>30.000</b> 1.1811	<b>62.9</b> 14100	<b>79.000</b> 3.1102	<b>15.000</b> 0.5906	<b>-4.8</b> -0.19
<b>180.000</b> 7.0866	<b>268.000</b> 10.5512	<b>260.000</b> 10.2362	<b>30.000</b> 1.1811	<b>63.6</b> 14300	<b>84.000</b> 3.3071	<b>15.000</b> 0.5906	<b>-1.8</b> -0.07
<b>200.000</b> 7.8740	<b>290.000</b> 11.4173	<b>282.000</b> 11.1024	<b>32.000</b> 1.2598	<b>74.6</b> 16800	<b>83.000</b> 3.2677	<b>17.000</b> 0.6693	<b>-0.8</b> -0.03
<b>220.000</b> 8.6614	<b>316.000</b> 12.4409	<b>308.000</b> 12.1260	<b>32.000</b> 1.2598	<b>80.8</b> 18200	<b>83.000</b> 3.2677	<b>17.000</b> 0.6693	<b>-5.3</b> -0.21
<b>270.000</b> 10.6299	<b>385.000</b> 15.1575	<b>375.000</b> 14.7638	<b>40.000</b> 1.5748	<b>114.0</b> 25700	<b>105.000</b> 4.1339	<b>20.000</b> 0.7874	<b>0.0</b> 0.00
<b>285.750</b> 11.2500	<b>385.000</b> 15.1575	<b>375.000</b> 14.7638	<b>40.000</b> 1.5748	<b>114.0</b> 25700	<b>105.000</b> 4.1339	<b>20.000</b> 0.7874	<b>0.0</b> 0.00

<sup>(1)</sup>Negative value indicates effective center within the width of the inner ring.

<sup>(2)</sup>The Timken Company life calculations based on 90 million revolutions for L10 life.



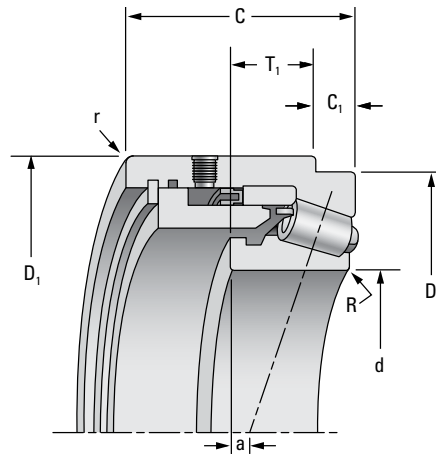

Hydra-Rib Part Number	Mounting Dimensions			Stiffness			
	R Shaft Radius	Shaft Shoulder Dia.	r Housing Radius	$K_r (10^6)$	$F_r$	$K_a (10^6)$	$F_a$
	mm in.	mm in.	mm in.	N/mm lbs./in.	kN lbs.	N/mm lbs./in.	kN lbs.
JP13043P-JP13016HR	<b>3.0</b>	<b>138.0</b>	<b>1.0</b>	<b>2.78</b>	<b>4.99</b>	<b>0.200</b>	<b>2.50</b>
	0.12	5.43	0.04	15.9	1120	1.14	561
JP13049P-JP13016HR	<b>3.0</b>	<b>138.0</b>	<b>1.0</b>	<b>2.78</b>	<b>4.99</b>	<b>0.200</b>	<b>2.50</b>
	0.12	5.43	0.04	15.9	1120	1.14	561
JP14043P-JP14019HR	<b>3.0</b>	<b>148.0</b>	<b>1.0</b>	<b>2.75</b>	<b>5.06</b>	<b>0.406</b>	<b>3.62</b>
	0.12	5.83	0.04	15.7	1140	2.32	813
JP14049P-JP14019HR	<b>3.0</b>	<b>152.0</b>	<b>1.0</b>	<b>2.75</b>	<b>5.06</b>	<b>0.406</b>	<b>3.62</b>
	0.12	5.98	0.04	15.7	1140	2.32	813
JP16043P-JP16019HR	<b>3.0</b>	<b>169.0</b>	<b>1.0</b>	<b>3.16</b>	<b>6.09</b>	<b>0.441</b>	<b>4.24</b>
	0.12	6.65	0.04	18.0	1370	2.52	953
JP16049P-JP16019HR	<b>3.0</b>	<b>172.0</b>	<b>1.0</b>	<b>3.16</b>	<b>6.09</b>	<b>0.441</b>	<b>4.24</b>
	0.12	6.77	0.04	18.0	1370	2.52	953
JP17049P-JP17019HR	<b>3.0</b>	<b>182.0</b>	<b>1.0</b>	<b>3.36</b>	<b>6.29</b>	<b>0.432</b>	<b>4.19</b>
	0.12	7.17	0.04	19.2	1410	2.47	943
JP18049P-JP18019HR	<b>3.0</b>	<b>193.0</b>	<b>1.0</b>	<b>3.44</b>	<b>6.36</b>	<b>0.495</b>	<b>4.49</b>
	0.12	7.60	0.04	19.6	1430	2.83	1010
JP20049P-JP20019HR	<b>3.0</b>	<b>213.0</b>	<b>1.0</b>	<b>3.47</b>	<b>7.46</b>	<b>0.471</b>	<b>5.12</b>
	0.12	8.39	0.04	19.8	1680	2.69	1150
JP22049E-JP22019HR	<b>3.0</b>	<b>233.0</b>	<b>1.0</b>	<b>3.93</b>	<b>8.08</b>	<b>0.644</b>	<b>6.09</b>
	0.12	9.17	0.04	22.4	1820	3.68	1370
JL555235-JL55512HR	<b>4.0</b>	<b>293.0</b>	<b>4.0</b>	<b>6.19</b>	<b>11.40</b>	<b>0.666</b>	<b>6.98</b>
	0.16	11.54	0.16	35.4	2570	3.81	1570
JL555239-JL55512HR	<b>4.0</b>	<b>293.0</b>	<b>4.0</b>	<b>6.19</b>	<b>11.40</b>	<b>0.666</b>	<b>6.98</b>
	0.16	11.54	0.16	35.4	2570	3.81	1570

***TAPERED ROLLER BEARING  
BORE DIAMETERS  
FOUND IN THIS CATALOG***

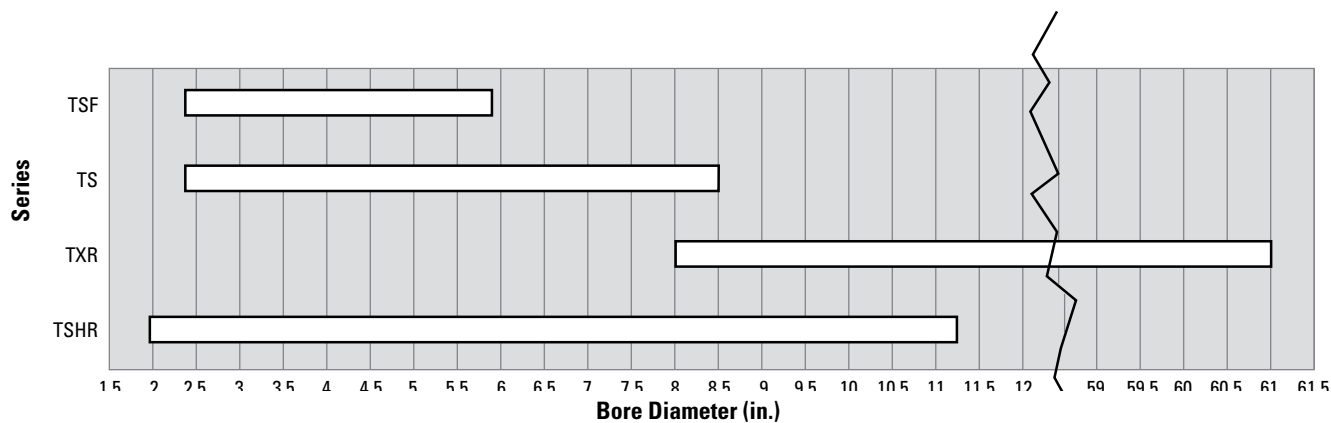
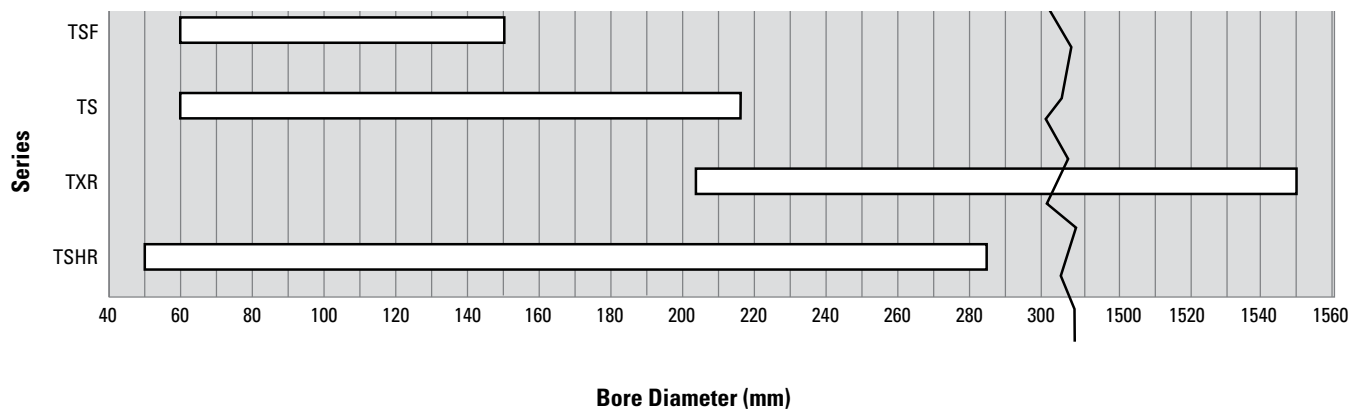

**Fig. 109. Bore diameters.**



***SUPER PRECISION  
BALL BEARINGS***

The following topics are covered within this section:

Nomenclature .....	120
Bearing Types.....	125
Applications .....	128
Spindle Bearings .....	132
Ball Screw Support Bearings .....	194
Ex-Cell-O Spindle Bearings .....	212
Ball Bearing Bore Diameters Found In This Catalog .....	214

**NOMENCLATURE**

**ISO**

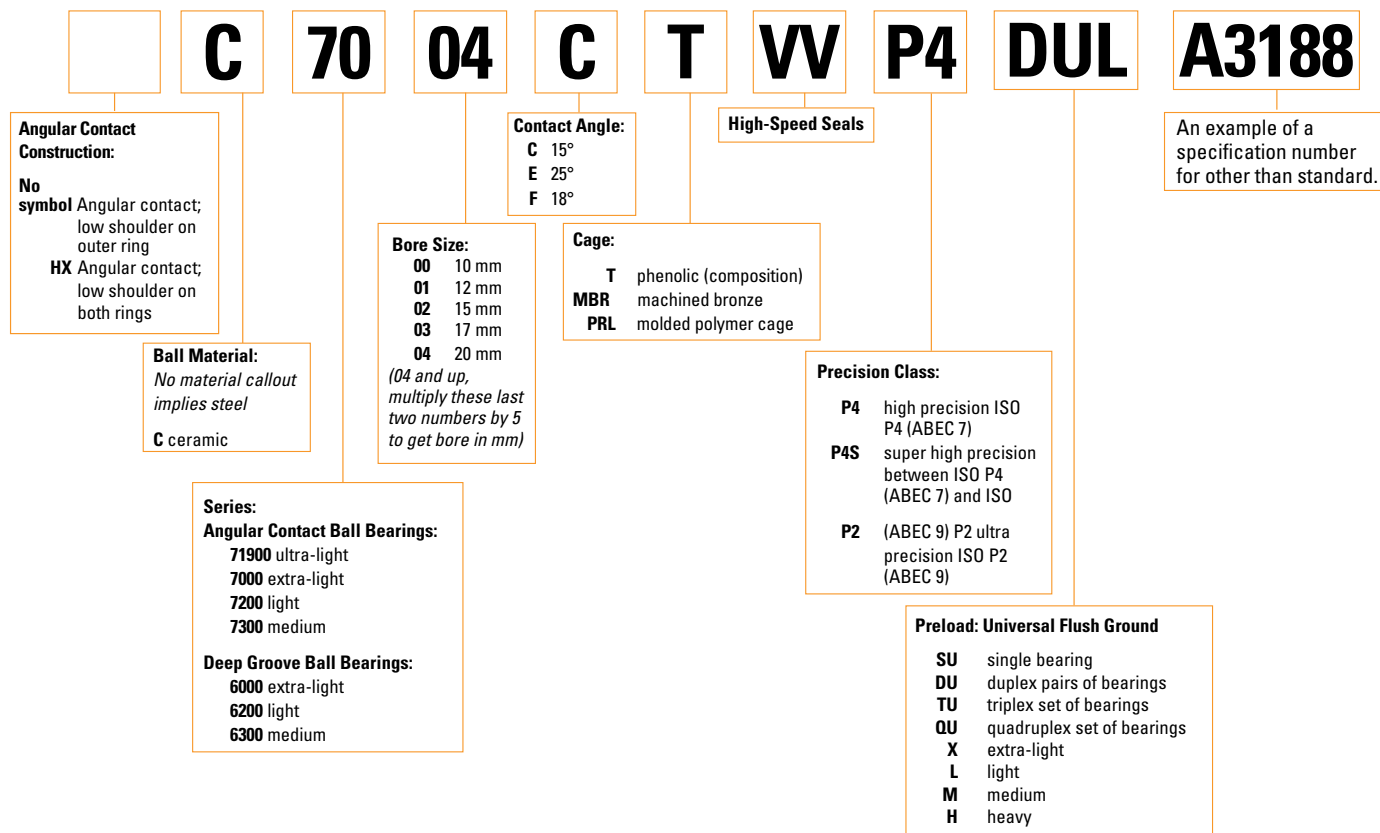

**Fig. 110. ISO nomenclature.**

SUPER PRECISION BALL BEARINGS  
ANGULAR CONTACT

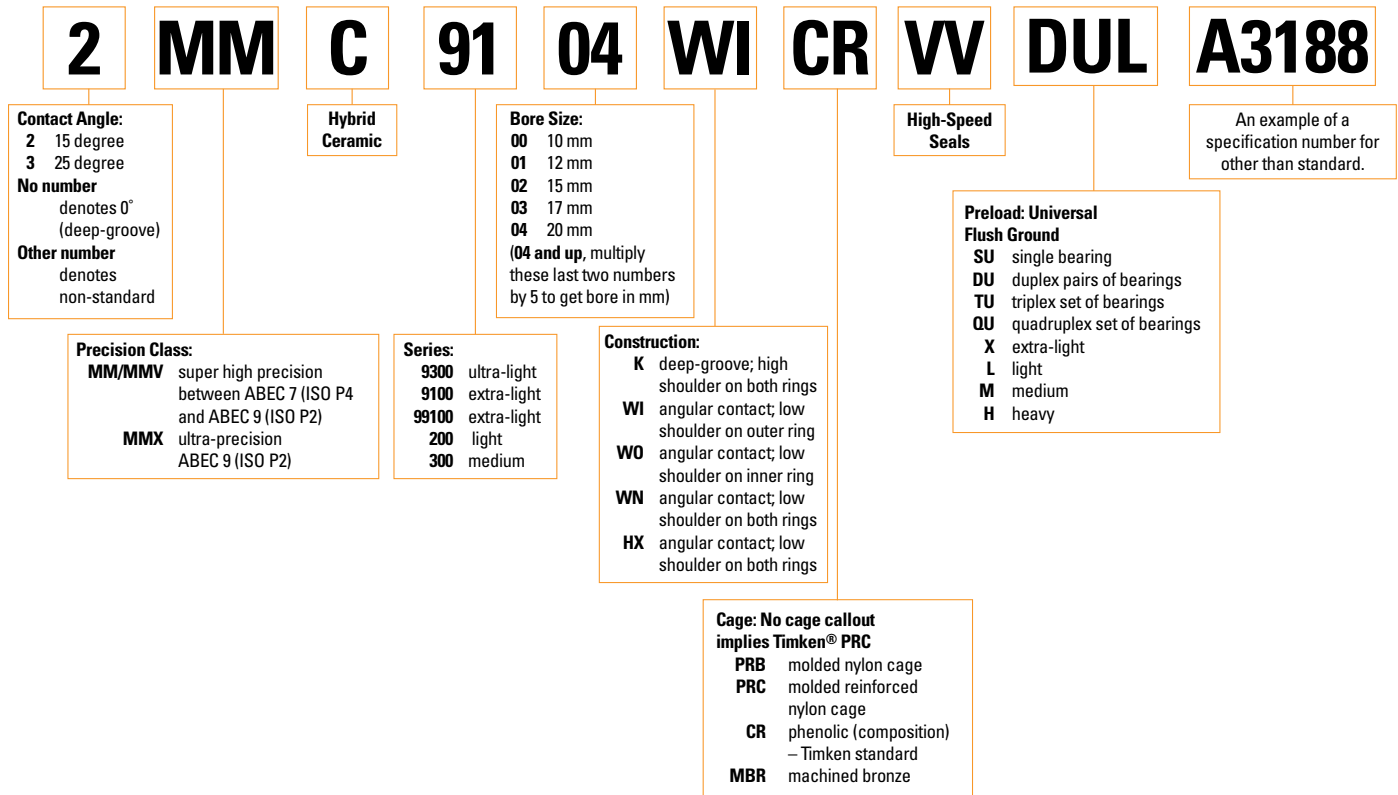

Fig. 111. Super precision ball bearings, angular contact nomenclature.

### SUPER PRECISION BALL BEARINGS BALL SCREW SUPPORT – DOUBLE ROW METRIC

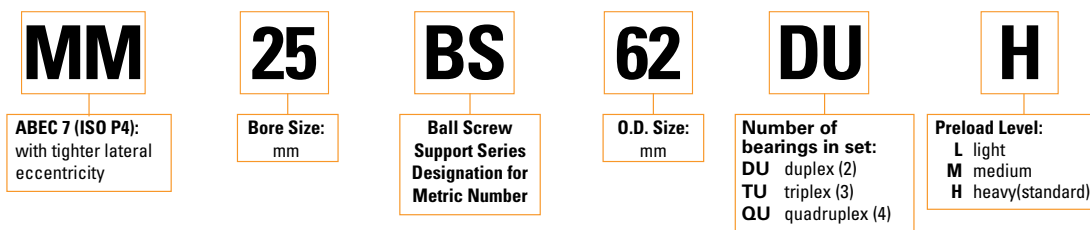

Fig. 112. Super precision ball bearing, ball screw support, single-row nomenclature - metric.

### INCH

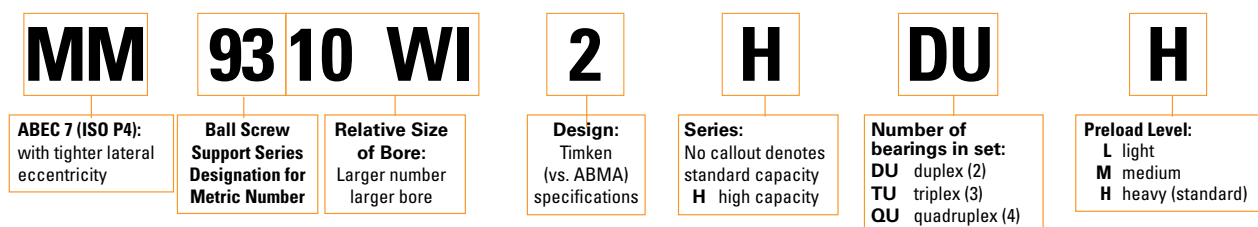

Fig. 113. Super precision ball bearing, ball screw support, single-row nomenclature - inch.

**SUPER PRECISION BALL BEARINGS  
BALL SCREW SUPPORT – DOUBLE ROW  
METRIC**

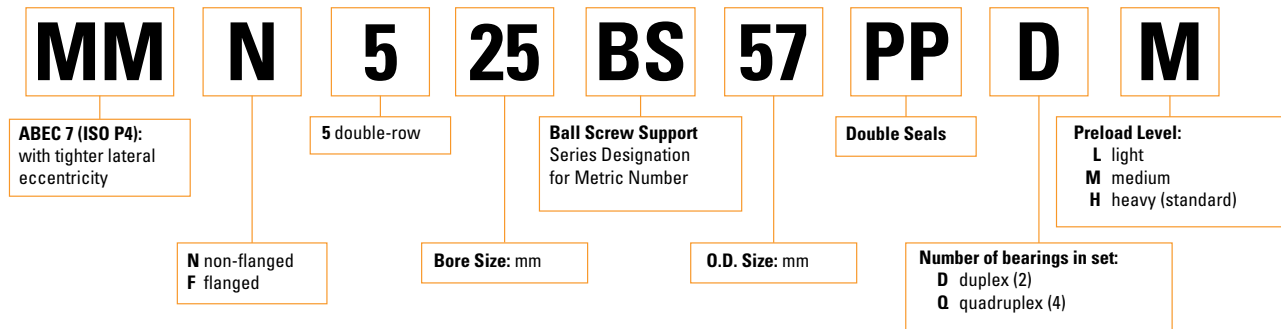

Fig. 114. Super precision ball bearing, ball screw support, double-row nomenclature - metric.

**SUPER PRECISION BALL BEARINGS  
BALL SCREW CARTRIDGE UNITS  
METRIC**

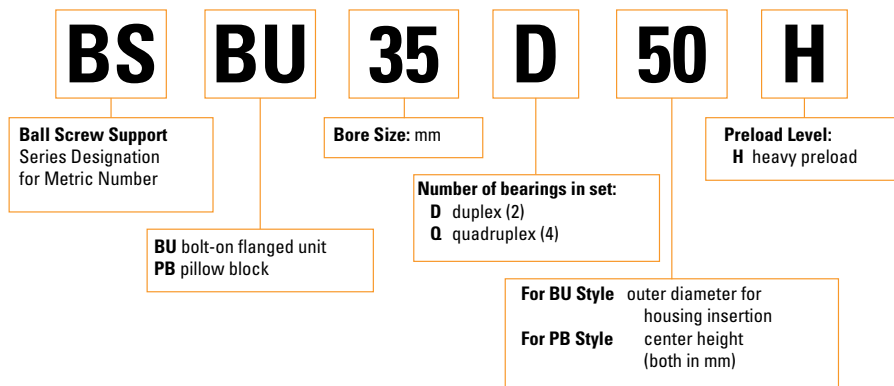

Fig. 115. Super precision ball bearing, ball screw cartridge units nomenclature - metric.

### MEANINGS OF PREFIXES AND SUFFIXES

In the Timken numbering system, the basic number, which denotes the size and series, is always retained. When special variations are made, as in the case of precision bearings, prefixes and suffixes are added, which have definite meanings as follows:

<b>MV P4</b>	High Precision, ABEC 7 (ISO P4)
<b>MM (P4S)</b>	Super Precision, ABEC 7/ABEC 9 (ISO P4/P2)
<b>2MM/2MMV</b>	
<b>(C-P4S)</b>	Super Precision between ABEC 7 and ABEC 9 (ISO P4/P2), Low contact angle - 15 degree
<b>3MM/3MMV</b>	
<b>(E-P4S)</b>	Super Precision between ABEC 7 and ABEC 9 (ISO P4/P2), High contact angle - 25 degree
<b>MMX (P2)</b>	Ultra-precision, ABEC 9, (ISO P2)
<b>K(6)</b>	Deep-groove high shoulder on both inner and outer ring
<b>W(7)</b>	Angular contact low shoulder on outer ring
<b>HX(7)</b>	Angular contact low shoulder on both inner and outer ring
<b>CR(T)</b>	Composition cage (non-metallic)
<b>MBR</b>	Machined bronze cage
<b>SR</b>	Machined steel cage
<b>PRB</b>	Molded nylon cage
<b>PRC</b>	Molded nylon cage (reinforced)
<b>PRL</b>	Molded reinforced nylon cage
<b>PRF, PRG</b>	Special high-performance material
<b>SUL</b>	Universally ground single bearing, Light preload
<b>SUM</b>	Universally ground single bearing, Medium preload
<b>SUH</b>	Universally ground single bearing, Heavy preload
<b>DUL</b>	Universally ground duplex bearings, Light preload
<b>DUM</b>	Universally ground duplex bearings, Medium reload
<b>DUH</b>	Universally ground duplex bearings, Heavy preload
<b>TUL</b>	Universally ground triplex bearings, Light preload
<b>TUM</b>	Universally ground triplex bearings, Medium preload
<b>TUH</b>	Universally ground triplex bearings, Heavy preload
<b>QUL</b>	Universally ground quadruplex bearings, Light preload
<b>QUM</b>	Universally ground quadruplex bearings, Medium preload
<b>QUH</b>	Universally ground quadruplex bearings, Heavy preload

### PERFORMANCE

The most widely recognized definition of quality is contained within the ABEC/ISO classes; however some factors affecting performance of a bearing are not completely defined within these standards. This allows for a significant range of variability in product performance among bearing manufacturers. To provide premium performance, all Timken ball bearing MV(P4), MM(P4S), MMV(P4S) and MMX(P2) precision grades comply with strict controls over these non-specified parameters – all of which can have a direct impact on the service life and performance of a bearing.

### OPTIMIZED GRADES OF PRECISION

#### MV (P4) – HIGH PRECISION (ABEC 7, ISO P4)

Precision bearings manufactured to the MV tolerance class operate with running accuracy, performance levels and dimensional controls meeting ABEC 7 (ISO P4). Bore and O.D. surfaces are coded in micron units to help with selection of the appropriate tolerance spread for universal adjacent-mounting to ensure optimum shaft and housing fits.

#### MM, MMV (P4S) – SUPER PRECISION, SUPER HIGH PRECISION (ABEC 7/9, ISO P4/P2)

Super precision bearings manufactured to the MM(V) tolerance class operate with running accuracy and performance levels meeting ABEC 9 (ISO P2) and remaining features at ABEC 7 (ISO P4) levels. Bore and O.D. surfaces are coded in micron units for the convenience of the discriminating machine tool builder striving for optimum fitting of crucial spindle components.

#### MMX (P2) – ULTRA-PRECISION (ABEC 9, ISO P2)

Super precision bearings with closer tolerances and running accuracies than ABEC 7 (ISO P4) bearings are made to ABEC 9 (ISO P2) tolerances. Bearings produced to these tolerances are generally used on ultra-high-speed grinding spindles designed for tight dimensional tolerances and superfine surface finishes. Contact your Timken representative for availability of product range.



## BEARING TYPES

### ANGULAR-CONTACT BEARINGS

#### 2MV-WI (7-C-P4)

2MV-WI (7-C-P4) types with 15 degree initial contact angle are designed to meet the needs of machine builders for precision bearings that are highly precise, cost effective and are radially stiff while also accommodating thrust loads to a certain extent. As a result, these bearings are used extensively in cutting tools, live spindles and textile applications.

#### 3MV-WI (7-E-P4)

3MV-WI (7-E-P4) bearings are manufactured with a 25 degree initial contact angle and exhibit a high axial rigidity and take up relatively higher axial loads. These bearings are the common choice for use in precision commercial lathes and vertical spindle applications.

#### 2MM-WI (7-C-P4S)

2MM-WI (7-C-P4S) types with 15 degree initial contact angle are designed to meet the needs of machine builders for precision bearings that will operate at as low a temperature as possible for a wide range of speeds and operating loads. In order for machines to produce more accurate work at a higher production rate, the bearings must provide a high degree of rigidity in both axial and radial directions while operating at minimum temperatures. For example, precision machining or cutting tools impose heavier loads on bearings than those encountered in precision grinding. In the former, speeds are slower and loads heavier than the latter, where speeds are high and loads light. The 2MM-WI (7-C-P4S) Type gives the machine builder the flexibility required to meet such variations in applications.

#### 3MM-WI (7-E-P4S)

3MM-WI (7-E-P4S), manufactured with 25 degree initial contact angle, are for use on applications where the loading on the initial bearings is predominately axial and a high degree of axial rigidity required. Typical applications for these are large vertical rotary surface grinders, horizontal and vertical disc grinders, and thrust bearing applications for heavy-duty lathes where the bearings must directly carry extremely high tail stock or chucking pressure.



**Fig. 116.**  
7-C-P4, 7-E-P4,  
7-C-P4S and  
7-E-P4S Types  
(7-C-P4S and  
7-E-P4S).

#### 2MMV AND 3MMV-HX (HX7-C-P4S AND HX7-E-P4S)

2MMV and 3MMV-HX (HX7-C-P4S and HX7-E-P4S) are dimensionally interchangeable with equivalent 9100, 99100, 9300 and ISO Series 10 and 19 bearings. These designs enable spindle heads to remove more material in less time while maintaining superior machining tolerances. This is achieved through a proven combination of unique ball complements with precision engineering of raceway geometries.



**Fig. 117.**  
2MMV-HXVV and  
3MMV-HXVV  
Types  
(HX7-C-VV-P4S  
and  
HX7-E-VV-P4S).

#### 2MMV AND 3MMV-HX VV (HX7-C-VV-P4S AND HX7-E- VV-P4S)

2MMV and 3MMV-HX VV (HX7-C-VV-P4S and HX7-E-VV-P4S) possess all of the high-speed advantages of the HX but add pre-lubrication and true-high-speed seals. These bearing seals help protect the lubricant from outside contaminants while ensuring internal lubricant retention.



**Fig. 118.**  
MM9300WI DUH  
(Inch)  
MM-BS-DUH  
(Metric).

## BALL SCREW SUPPORT BEARINGS

To meet the demands of the servo-controlled machinery field, the Timken® ball screw support bearings (BSSB) are specially designed with steep contact angles and offer high levels of stiffness for ball screw application requirements. Timken's most recent product offering in this area is a series of double-row, sealed, flanged (or cartridge) units that use an integral double-row outer ring to help simplify installation procedures. Timken offers the following ball screw support bearing products:

- Inch Series BSSB (MM9300).
- Metric Series BSSB (MMBS).
- Flanged cylindrical cartridge housed units (BSBU).
- Pillow block housed units (BSPB).
- Integral double-row units (MMN, MMF).

### MICRON BORE AND O.D. CODING FOR BALL BEARINGS

To better match machine tool bearings to spindles, Timken offers micron coding for its super precision angular contact ball bearing line. (Micron coding is standard on all products except ball screw support bearings and Ex-Cell-O bearings.)

Micron coding is based on average bore and O.D. diameters. This type of coding indicates the deviation from the nominal size in microns.

Multiple bearing set coding will reflect maximum O.D. and minimum bore diameters found within the set.

The coding is marked on the inner and outer rings and on the box label.

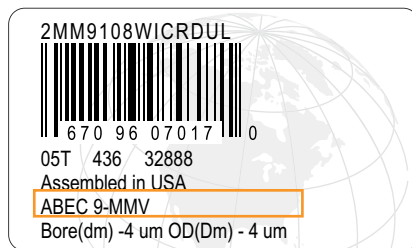
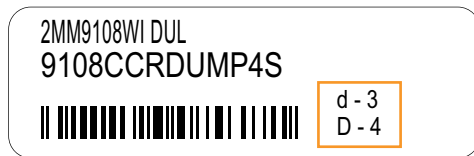

Fig. 119. Packaging coding.

TABLE 70. DEVIATION FROM NOMINAL.

Micron coding	Micron		Inch	
	Over	Incl.	Over	Incl.
1	0	-1	0.000000	-0.000039
2	-1	-2	-0.000039	-0.000079
3	-2	-3	-0.000079	-0.000118
4	-3	-4	-0.000118	-0.000157
5	-4	-5	-0.000157	-0.000197
6	-5	-6	-0.000197	-0.000236
7	-6	-7	-0.000236	-0.000276
8	-7	-8	-0.000276	-0.000315
9	-8	-9	-0.000315	-0.000354
10	-9	-10	-0.000354	-0.000394
11	-10	-11	-0.000394	-0.000433
12	-11	-12	-0.000433	-0.000472
13	-12	-13	-0.000472	-0.000512

### BALL SCREW SUPPORT BEARING MOUNTING ARRANGEMENTS

An alignment mark is placed on the outer rings of bearing sets as shown. This mark is in the form of a "V" when bearings are in the "O" arrangement (triplex and quadruplex sets only).

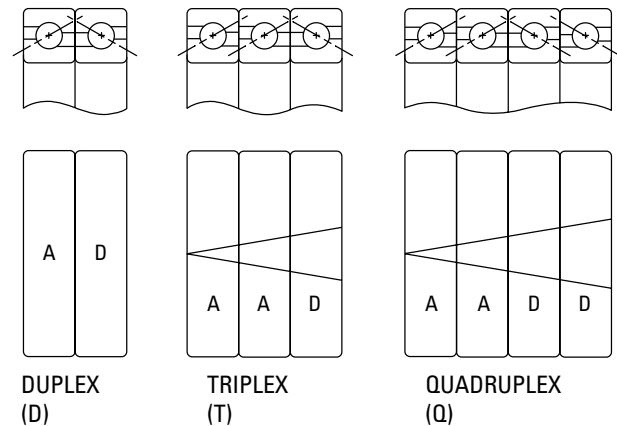

Fig. 120. Ball screw support bearing mounting configurations.

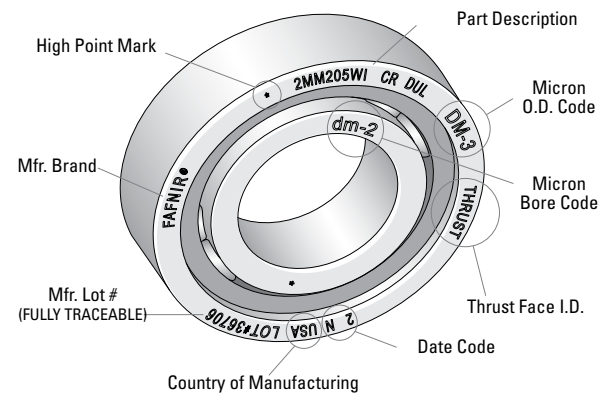
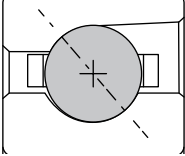
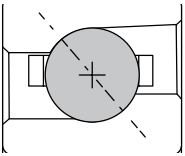
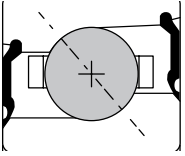
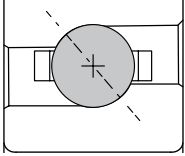
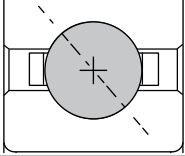
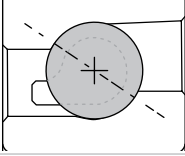
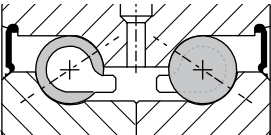
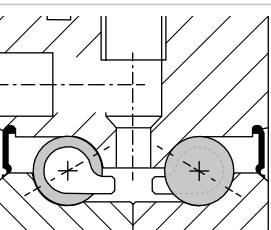

Fig. 121. Super precision markings.

**TABLE 71.  
TIMKEN'S PRECISION PRODUCT OFFERING**

	Series	Design		Size Series	Precision	Contact Angle	Features	
Ball Bearings	Spindle Bearings		WI	9300 (71900) 9100 (7000) 200 (7200) 300 (7300)	MV, MM MV, MM MV, MM MM	15°, 25°	High capacity design with outer piloted cage. Ball-piloted cage (PRL) available in 9100 and 200 series.	
			HX	9300 (71900) 9100 (7000)	MMV	15°, 25°	High-speed design with outer piloted cage.	
			HXVV	9300 (71900) 9100 (7000)	MMV	15°, 25°	Sealed high-speed design with outer piloted cage.	
			WN	99100	MMV	15°, 25°	High rigidity design with outer piloted cage.	
			K	9100 (7000) 200 (7200) 300 (7300)	MM	0°	Radial (deep groove) bearing with inner piloted cage.	
	Ball Screw Support Bearings	Double Row		Single Row	200 (7200) 300 (7300)	MM	60°	Single-row high axial capacity and rigidity design with ball-piloted cage.
				MMN		MM	60°	Sealed double-row high axial capacity design with split inner rings.
				MMF		MM	60°	Flanged and sealed double-row high axial capacity design with split inner rings and optional snap ring.

### APPLICATIONS

Workhead and tool spindles are often the most important components of machine tools. Consequently, to reach the requirements for spindle speed, work accuracy and finish, selection of the proper size and type of ball bearings to support these spindles is critical.

Of all the rolling bearing types, super precision ball bearings have proved to be the best value for the wide variety of machine tool bearing applications, which cover broad ranges of operating loads, speeds and lubrication conditions. Duplexed, preloaded, angular contact bearings with one-piece composition cages have excellent capacity and provide maximum spindle rigidity. These bearings are widely used to help machines achieve faster speeds, greater accuracy, smoother finishes and higher production rates.

Many considerations are involved in the choice of bearings for precision applications. Among those that influence the performance of machine tool spindles are the internal geometry of the bearings, the mounting arrangement, the shaft and housing mounting fits, the balance and alignment of the rotating parts, and last, but equally important, the lubrication. While many of these factors are significant in slow-speed applications, all of them must be considered for high-speed spindles.

To minimize deflection under load, shafts for machine tool spindles are designed to have a minimum unsupported length and maximum cross section. For the same reason, spindle housings are designed heavy enough to carry the work load. Their cross sections are made as uniform as possible to reduce stress concentration during uneven deflection of the frame due to thermal changes. In addition, heavy, well-proportioned housings can function as sinks to conduct heat away from ball bearings.

### SELECTIVE ASSEMBLY

Under certain conditions, it may be desirable to control fits more accurately without the added expense of using tighter tolerance bearings and assembly parts. This can be accomplished by selective assembly of the bearings, shafts and housings after they are sized and sorted according to bores and outside diameters. Timken provides bore and O.D. micron coding as standard practice for super precision angular contact radial ball bearings. This improved fit-up at assembly helps to maximize spindle precision.

### APPLICATION EXAMPLES

Detailed assembly drawings on the following pages are representative of successful applications of Timken® super precision ball bearings; high-cycle wheel heads; high-speed internal grinding spindles; super precision workheads; and high-speed router spindles. Contact your Timken representative regarding any of your application problems.

### SPECIAL REQUIREMENTS

High-speed, grease-lubricated spindles and heavy-precision workheads requiring unusual rigidity and running accuracy are a few of the many special problems involving super precision bearings. These and many other applications generally require design features that can be reviewed by your Timken representative.

#### HIGH-SPEED INTERNAL-GRINDING SPINDLE

Designed for internal precision grinding, this spindle incorporates 2MM9106WI-CR (7006C-T-P4S) super precision ball bearings, preloaded by a coiled helical spring cartridge. Thrust load exerted by the springs ensures close contact of the balls with the bearing raceways under all operating conditions. The sealed construction provides highly effective protection against intrusion of coolant and foreign matter. Grease is packed and sealed in each bearing prior to assembly. Operating speed of this spindle is 25000 RPM.

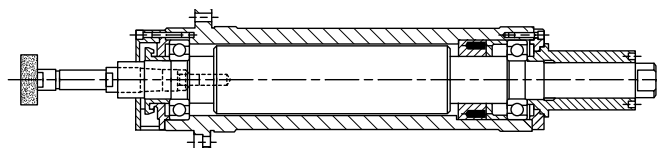

Fig. 122. High-speed internal-grinding spindle.

#### ULTRA-PRECISION SURFACE-GRINDING SPINDLE

2MMX9122WI-DUM (7022C-P2-DUM) super precision bearings, produced to ABEC 9 (ISO P2) tolerances, are employed in this horizontal surface-grinding spindle for maximum rigidity and accuracy. A back-to-back pair of 2MM312WI-CR-DUL (7312C-CR-P4S-DUL) super precision bearings is used at the floating location. This spindle grinds surfaces that are accurate within 0.0006 mm (0.000025 in.), flat and parallel, square within 0.0003 mm (0.000010 in.), to a surface finish of 5 rms, or better. The spindle, driven by a 30 hp motor, operates at 900 RPM. Bearings are packed with grease prior to assembly.

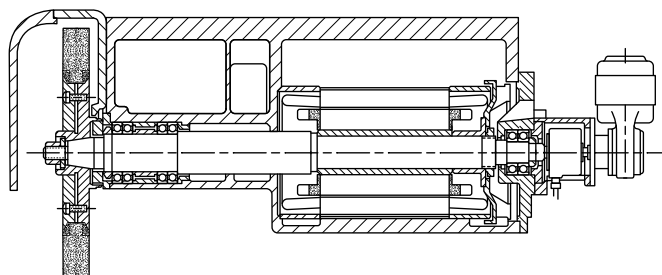
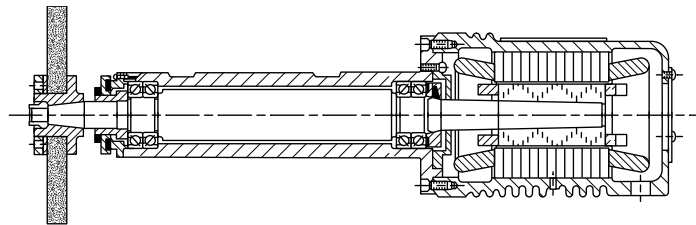

Fig. 123. Ultra-precision surface-grinding spindle.

**PRECISION SURFACE-GRINDING SPINDLE**

This motorized surface-grinding spindle, operating at 3600 RPM, uses 2MM9107WI-DUM (7007C-P4S-DUM) duplex super precision preloaded bearings at both locations, mounted back-to-back, with one pair floating. Labyrinth slinger-type sealing prevents entry of contaminants and seals in the grease lubrication.



**Fig. 124. Precision surface-grinding spindle.**

**HEAVY-DUTY PRECISION-BORING SPINDLE**

Super precision, duplexed, preloaded bearings mounted back-to-back are used at each location in this boring spindle to help ensure smooth performance and a high degree of radial and axial rigidity. Operating speeds vary between 200 and 3000 RPM. Equal-length spacers between the bearings at the workend increase spindle rigidity. When the bearings are properly positioned on the shaft and the respective rings securely clamped, the preload is reproduced and no subsequent adjustment is required. Just prior to assembly, each bearing is packed with grease.

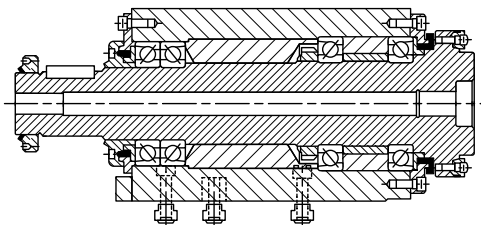
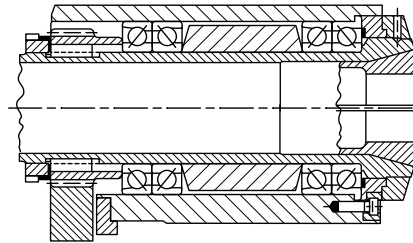

**Fig. 125. Heavy-duty precision-boring spindle.**

**SIX-SPINDLE AUTOMATIC-SCREW MACHINE**

This bearing arrangement meets the demand for a high-speed, heavy-duty, multiple-spindle screw machine to operate with constant accuracy at maximum production. Because of the hollow shaft construction and the short distance between bearings, extra-light series duplex pairs are used at each location. This affords a high degree of radial rigidity and adds stiffness to the shaft. By mounting a duplex pair of flanged (3MMF) (F-E-P4S) bearings back-to-back with a duplexed pair of 2MM (C-P4S) super precision bearings, accuracy

and rigidity of the spindle are ensured and permit a straight housing bore. The rear pair of back-to-back bearings is allowed to float in the housing. Lubrication is by pressure-feed oil circulation.



**Fig. 126. Six-spindle automatic-screw machine.**

**HIGH-SPEED PRECISION-BORING HEAD**

This high-speed boring head operates at 2500 to 3000 RPM, employing angular contact super precision bearings. The front bearings are of different sizes. The outer ring of the larger bearing abuts and is clamped against the housing shoulder. The inboard bearing is permitted to move axially in its housing under spring load. At the rear location, two spring-loaded bearings of the same size are allowed to float in the housing as temperature differentials occur in the operation spindle. With this head, interference shaft fits may be permitted without affecting bearing preload. Excessive heat generation is prevented, resulting in lower operating temperatures. Bearings are grease lubricated.

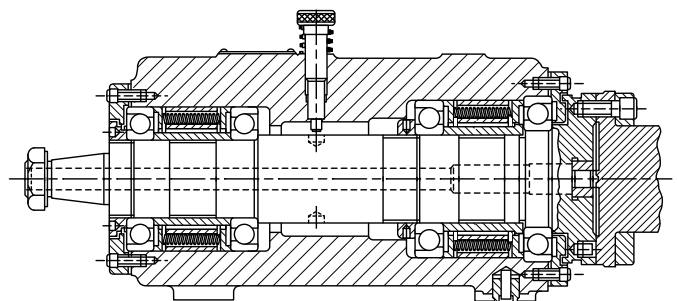

**Fig. 127. High-speed precision-boring head.**

### ULTRA-PRECISION GRINDING WORKHEAD

This workhead must maintain straightness and roundness accuracy within 0.00025 mm (0.000010 in.). To meet such rigid requirements for extremely close dimensional control, ultra-precision ball bearings and a shaft of extra stiffness are used. The bearings for such applications are manufactured to tolerances closer than those for ABEC 9 (ISO P2) specifications. Equally important is the high degree of workmanship and accuracy in which the shaft, housing and component parts of the workhead must be made. The upper section shows a four-bearing arrangement for heavy work. The lower half shows a two-bearing mounting for lighter work. Bearings are packed with grease prior to mounting.

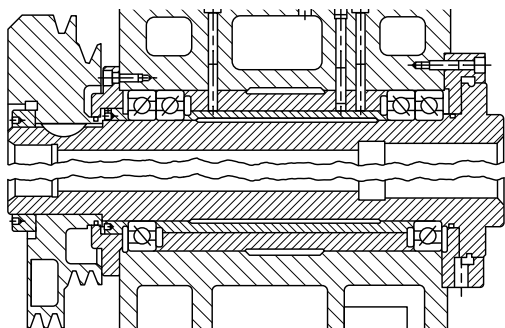

Fig. 128. Ultra-precision grinding workhead.

### PRECISION TOOLROOM SURFACE GRINDER SPINDLE

Timken duplexed, super precision, preloaded bearings used in this spindle provide a high degree of rigidity in both radial directions that is necessary to meet modern surface grinding requirements. This design provides more efficient performance at a lower operating temperature. The housing is bored straight through to assure true alignment; the housing shoulders are eliminated. The precision-ground outer sleeve is doweled to the housing to provide the means for stabilizing the spindle axially at the workend bearing location. The rear pair of bearings floats to compensate for thermal changes. Bearings are grease lubricated prior to assembly.

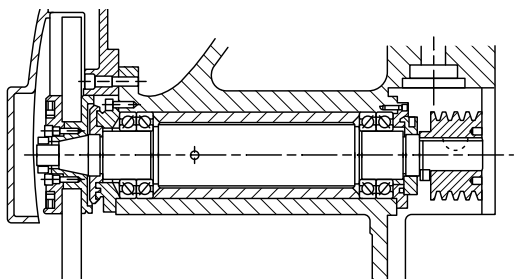

Fig. 129. Precision toolroom surface grinder spindle.

### SINGLE-BAR MACHINE

This spindle is supported by two pairs of 2MM9124WI-DUM (7024C-P4S-DUM) super precision bearings mounted back-to-back in tandem pairs. Operating speeds vary from 78 to 1500 RPM. A pair of 2MM9122WI-DUM (7022C-P4S-DUM) bearings mounted in tandem carries a 11340 kg (25000 lb.) thrust load during the unchucking operation. The bearings are grease packed prior to assembly.

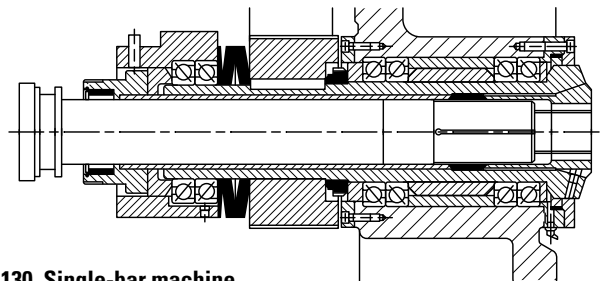

Fig. 130. Single-bar machine.

### 100000 RPM HIGH-CYCLE WHEELHEAD

Super precision 2MMX9101W0-CR (W07001C-T-P2) bearings produced to ABEC 9 (ISO P2) tolerances are spring-loaded in this wheelhead, which operates at 100000 RPM. Oil-mist lubrication is employed and the motor is water cooled.

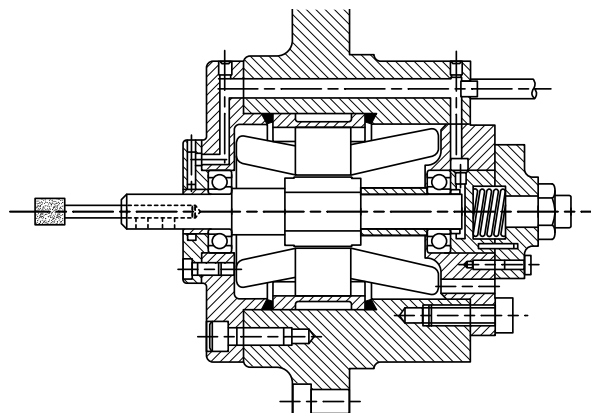
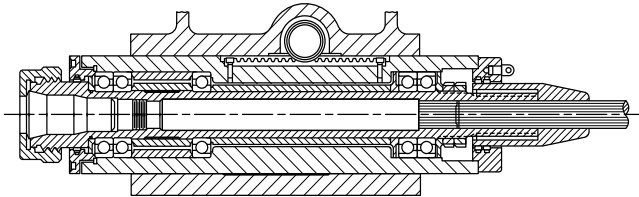

Fig. 131. 100000 RPM high-cycle wheelhead.



**PRECISION JIG-BORING SPINDLE**

This jig-boring spindle delivers extreme accuracy over a wide range of speeds. It is supported with 2MM210WI-DUM (7210C-P4S-DUM ) grease-lubricated super precision bearings. With this spindle, holes located to an accuracy of 0.0025 mm (0.0001 in.) are bore-ground straight and to size limits of better than 0.005 mm (0.0002 in.).



**Fig. 132. Precision jig-boring spindle.**

**SUPER PRECISION LATHE HEADSTOCK**

This lathe spindle produces work held to a roundness of 0.0009 mm (0.000035 in.). Maximum operating speed is 4800 RPM. A tandem pair of 3MM9114WI-DUL (7014E-P4S-DUL) bearings is opposed by a spring-loaded 3MM9113WI (7013E-P4S) bearing, resulting in excellent spindle rigidity. Bearings are prelubricated with grease.

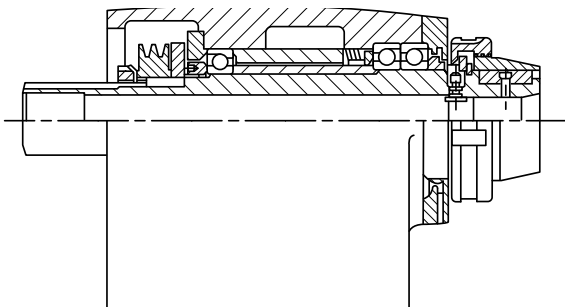

**Fig. 133. Super precision lathe headstock.**

**HIGH-SPEED MOTORIZED ROUTER**

A specially matched duplex pair of Timken 2MM210WI-DU-FS223 (7210C-P4S-DU-FS223 )super precision ball bearings, mounted back-to-back at the workend, affords the necessary bearing rigidity to permit routing through aluminum plate 25.400 mm (1.0000 in.) thick with a single pass. The upper bearing is spring-loaded and permitted to float. The router is driven by a 30 hp motor at speeds up to 15000 RPM and uses oil-mist lubrication.

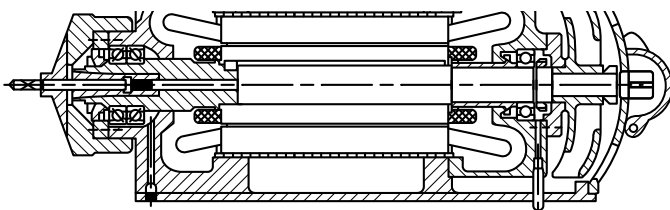
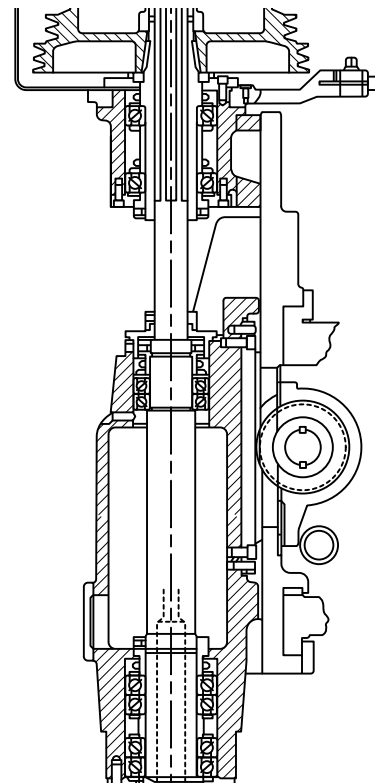

**Fig. 134. High-speed motorized router.**

**PRECISION VERTICAL MILLING SPINDLE**

This spindle operates at 12 different speeds ranging from 260 to 6200 RPM under a wide variety of conditions. At the workend, two duplex pairs of Timken 2MM212WI-DUL (7212C-P4S-DUL) preloaded bearings are mounted in tandem in a back-to-back arrangement, separated by spacers of equal length. This affords extremely high radial and axial rigidity. At the center, a pair of 2MM210WI-DUL (7210C-P4S-DUL ) bearings mounted back-to-back permits axial float of the spindle to compensate for thermal changes.

The driving pulley shaft is rigidly supported by a widely spaced duplex pair of 2MM212WI-DUL (7212C-P4S-DUL ) preloaded bearings. All bearings are grease packed.



**Fig. 135. Precision vertical milling spindle.**

**SPINDLE BEARINGS**  
**ULTRA-LIGHT ISO 19 SERIES**  
**2(3)MV/MM9300WI (71900C(E)-...-P4/P4S)**  
**HIGH PRECISION MV**

Running accuracy, performance and dimensional controls conform to ABEC 7 (ISO P4) requirements.

**SUPER PRECISION MM**

Running accuracy and performance meet ABEC 9 (ISO P2) levels. Other features conform to ABEC 7 (ISO P4) requirements.

**WI CONSTRUCTION**

- Incorporates low shoulder on non-thrust side of outer rings.
- Balls separated by one-piece cage piloted against a ground thrust shoulder land of the outer ring.

Bearing Number 15° C/2 <sup>(3)</sup> or 25° E/3 <sup>(4)</sup>	d Bore	D O.D.	C Width <sup>(1)</sup>	Ball Qty. x Dia.	Bearing Wt.	15° (C/2) Load Ratings						25° (E/3) Load Ratings					
						Steel Ball			Ceramic Ball			Steel Ball			Ceramic Ball		
						C <sub>0</sub> Static	C <sub>e</sub> Dynamic	Speed Rating <sup>(N<sub>g</sub>)</sup>	C <sub>0</sub> Static	C <sub>e</sub> Dynamic	Speed Rating <sup>(N<sub>g</sub>)</sup>	C <sub>0</sub> Static	C <sub>e</sub> Dynamic	Speed Rating <sup>(N<sub>g</sub>)</sup>	C <sub>0</sub> Static	C <sub>e</sub> Dynamic	Speed Rating <sup>(N<sub>g</sub>)</sup>
mm in.	mm in.	mm in.	mm in.	kg lbs.	N lbs.	N lbs.	RPM	N lbs.	N lbs.	RPM	N lbs.	N lbs.	RPM	N lbs.	N lbs.	RPM	
9300WI	10	22	6	12 x 3.2	0.010	1640	3510	77500	1460	3510	93000	1580	3380	69800	1410	3380	83760
71900	0.3937	0.8661	0.2362	12 x 1/8	0.02	370	790	77500	330	790	93000	360	760	69800	320	760	83760
9301WI	12	24	6	13 x 3.2	0.010	1840	3690	67200	1640	3690	80640	1770	3550	66500	1580	3550	79800
71901	0.4724	0.9449	0.2362	13 x 1/8	0.03	410	830	67200	370	830	80640	400	800	60500	350	800	79800
9302WI	15	28	7	13 x 3.6	0.020	2370	4560	55600	2110	4560	66720	2280	4360	50000	2030	4360	60000
71902	0.5906	1.1024	0.2756	13 x 3/16	0.04	530	1030	55600	470	1030	66720	510	980	50000	460	980	60000
9303WI	17	30	7	14 x 3.6	0.020	2800	4970	50100	2500	4970	60120	2680	4740	45100	2380	4740	54120
71903	0.6693	1.1811	0.2756	14 x 3/16	0.04	630	1120	50100	560	1120	60120	600	1070	45100	540	1070	54120
9304WI	20	37	9	15 x 4.8	0.040	4560	8080	42100	4050	8080	50520	4360	7700	41600	3880	7700	49920
71904	0.7874	1.4567	0.3543	15 x 3/16	0.08	1020	1820	42100	910	1820	50520	920	1730	37900	870	1730	49920
9305WI	25	42	9	17 x 4.8	0.040	5750	9040	34800	5120	9040	41760	5470	8590	31300	4860	8590	37560
71905	0.9843	1.6535	0.3543	17 x 3/16	0.10	1290	2030	34800	1150	2030	41760	1230	1930	31300	1090	1930	37560
9306WI	30	47	9	19 x 4.8	0.050	6610	9540	29700	5890	9540	35640	6270	9040	26700	5580	9040	32040
71906	1.1811	1.8504	0.3543	19 x 3/16	0.11	1490	2150	29700	1320	2150	35640	1410	2030	26700	1260	2030	32040
9307WI	35	55	10	19 x 5.6	0.080	9020	12600	25400	8020	12600	30480	8530	11600	22900	7590	11600	27500
71907	1.3780	2.1654	0.3937	19 x 7/16	0.17	2030	2830	25400	1800	2830	30480	1920	2680	22900	1710	2680	27500
9308WI	40	62	12	19 x 6.4	0.110	11700	16000	22400	10400	16000	26880	11100	15100	20200	9890	15100	24240
71908	1.5748	2.4409	0.4724	19 x 1/4	0.25	2640	3600	22400	2350	3600	26880	2500	3400	20200	2220	3400	24240
9309WI	45	68	12	21 x 6.4	0.130	13200	16800	20000	11700	16800	24000	12500	15900	18000	11100	15900	21600
71909	1.7717	2.6772	0.4724	21 x 1/4	0.29	2960	3785	20000	2640	3785	24000	2810	3560	18000	2500	3560	21600
9310WI	50	72	12	23 x 6.4	0.140	14600	17600	18300	13000	17600	21960	13800	16600	16500	12300	16600	19800
71910	1.9685	2.8346	0.4724	23 x 1/4	0.30	3290	3950	18300	2930	3950	21960	3100	3730	16500	2760	3730	19800
9311WI	55	80	13	23 x 7.1	0.190	18500	21800	16600	16400	21800	19920	17400	20600	14900	15500	20600	17900
71911	2.1654	3.1496	0.5118	23 x 7/16	0.41	4150	4900	16600	3700	4900	19920	3920	4620	14900	3490	4620	17900
9312WI	60	85	13	25 x 7.1	0.200	20200	22700	15300	18000	22700	18360	19000	21400	13800	16900	21400	16560
71912	2.3622	3.3465	0.5118	25 x 7/16	0.44	4540	5100	15300	4040	5100	18360	4270	4820	13800	3800	4820	16560
9313WI	65	90	13	27 x 7.1	0.220	21900	23600	14200	19500	23600	17040	20400	22200	12800	18100	22200	15360
71913	2.5591	3.5433	0.5118	27 x 7/16	0.47	4910	5290	14200	4370	5290	17040	4580	4990	12800	4080	4990	15360
9314WI	70	100	16	24 x 8.7	0.340	29000	32000	13100	25800	32000	15720	27300	30200	11800	24300	30200	14160

<sup>(N<sub>g</sub>)</sup>For a single, grease-lubricated, spring-preloaded bearing. This value to be used in permissible operating speed (Sp) calculation.

<sup>(1)</sup>Width tolerance of preloaded bearing set +0.000/-0.254 mm (+0.0000/-0.0100 in.).

<sup>(2)</sup>Fill weights based upon specific gravity of 0.99.

<sup>(3)</sup>C is ISO designation for 15° contact angle, 2 is Timken designation for 15° contact angle.

<sup>(4)</sup>E is ISO designation for 25° contact angle, 3 is Timken designation for 25° contact angle.



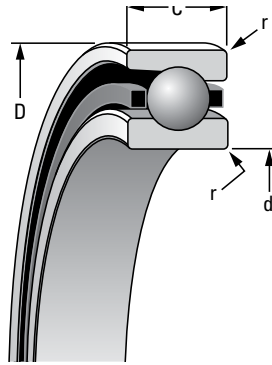

r Rad. <sup>(2)</sup>	Suggested Shoulder Diameters				Shaft Diameter		Mounting Fits		Fixed				Floating			
	Shaft		Housing						Housing Bore (Stationary)		Mounting Fits		Housing Bore (Stationary)		Mounting Fits	
	Max.	Min.	Max.	Min.					Max.	Min.	Tight	Loose	Max.	Min.	Loose	Loose
mm in.	mm in.	mm in.	mm in.	mm in.	mm in.	mm in.	mm in.	mm in.	mm in.	mm in.	mm in.	mm in.	mm in.	mm in.	mm in.	
<b>0.3</b>	<b>13.2</b>	<b>13.0</b>	<b>19.6</b>	<b>19.3</b>	<b>10.000</b>	<b>9.995</b>	<b>0.005</b>	<b>0.004</b>	<b>22.005</b>	<b>22.000</b>	<b>0.000</b>	<b>0.010</b>	<b>22.010</b>	<b>22.005</b>	<b>0.015</b>	<b>0.005</b>
0.012	0.52	0.51	0.77	0.76	0.39370	0.39350	0.00020	0.00015	0.86630	0.86610	0.00000	0.00040	0.86650	0.86630	0.00060	0.00020
<b>0.3</b>	<b>15.2</b>	<b>14.9</b>	<b>21.6</b>	<b>21.3</b>	<b>12.000</b>	<b>11.995</b>	<b>0.005</b>	<b>0.004</b>	<b>24.005</b>	<b>24.000</b>	<b>0.000</b>	<b>0.010</b>	<b>24.010</b>	<b>24.005</b>	<b>0.015</b>	<b>0.005</b>
0.012	0.60	0.59	0.85	0.84	0.47240	0.47220	0.00020	0.00015	0.94510	0.94490	0.00000	0.00040	0.94530	0.94510	0.00060	0.00020
<b>0.3</b>	<b>18.3</b>	<b>18.1</b>	<b>25.5</b>	<b>25.2</b>	<b>15.000</b>	<b>14.995</b>	<b>0.005</b>	<b>0.004</b>	<b>28.005</b>	<b>28.000</b>	<b>0.000</b>	<b>0.010</b>	<b>28.010</b>	<b>28.005</b>	<b>0.015</b>	<b>0.005</b>
0.012	0.72	0.71	1.00	0.99	0.59060	0.59040	0.00020	0.00015	1.02380	1.02360	0.00000	0.00040	1.02400	1.02380	0.00060	0.00020
<b>0.3</b>	<b>20.3</b>	<b>20.0</b>	<b>27.5</b>	<b>27.2</b>	<b>17.000</b>	<b>16.995</b>	<b>0.005</b>	<b>0.004</b>	<b>30.005</b>	<b>30.000</b>	<b>0.000</b>	<b>0.010</b>	<b>30.010</b>	<b>30.005</b>	<b>0.015</b>	<b>0.005</b>
0.012	0.80	0.79	1.08	1.07	0.66930	0.66910	0.00020	0.00015	1.18130	1.18110	0.00000	0.00040	1.18150	1.18130	0.00060	0.00020
<b>0.3</b>	<b>24.1</b>	<b>23.9</b>	<b>33.7</b>	<b>33.4</b>	<b>20.000</b>	<b>19.995</b>	<b>0.005</b>	<b>0.005</b>	<b>37.006</b>	<b>37.000</b>	<b>0.000</b>	<b>0.012</b>	<b>37.010</b>	<b>37.005</b>	<b>0.016</b>	<b>0.005</b>
0.012	0.95	0.94	1.33	1.32	0.78740	0.78720	0.00020	0.00020	1.45700	1.45670	0.00000	0.00050	1.45710	1.45690	0.00070	0.00020
<b>0.3</b>	<b>29.1</b>	<b>28.9</b>	<b>38.7</b>	<b>38.4</b>	<b>25.000</b>	<b>24.995</b>	<b>0.005</b>	<b>0.005</b>	<b>42.006</b>	<b>42.000</b>	<b>0.000</b>	<b>0.012</b>	<b>42.010</b>	<b>42.005</b>	<b>0.016</b>	<b>0.005</b>
0.012	1.15	1.14	1.52	1.51	0.98430	0.98410	0.00020	0.00020	1.65380	1.65350	0.00000	0.00050	1.65390	1.65370	0.00070	0.00020
<b>0.3</b>	<b>34.1</b>	<b>33.9</b>	<b>43.7</b>	<b>43.4</b>	<b>30.000</b>	<b>29.995</b>	<b>0.005</b>	<b>0.005</b>	<b>47.006</b>	<b>47.000</b>	<b>0.000</b>	<b>0.012</b>	<b>47.012</b>	<b>47.007</b>	<b>0.018</b>	<b>0.007</b>
0.012	1.34	1.33	1.72	1.71	1.18110	1.18090	0.00020	0.00020	1.85070	1.85040	0.00000	0.00050	1.85090	1.85070	0.00080	0.00030
<b>0.6</b>	<b>40.0</b>	<b>39.5</b>	<b>51.1</b>	<b>50.6</b>	<b>35.000</b>	<b>34.995</b>	<b>0.005</b>	<b>0.006</b>	<b>55.008</b>	<b>55.000</b>	<b>0.000</b>	<b>0.015</b>	<b>55.012</b>	<b>55.007</b>	<b>0.019</b>	<b>0.007</b>
0.024	1.57	1.55	2.01	1.99	1.37800	1.37780	0.00020	0.00025	2.16570	2.16540	0.00000	0.00060	2.16590	2.16570	0.00080	0.00030
<b>0.6</b>	<b>45.1</b>	<b>44.6</b>	<b>57.9</b>	<b>57.4</b>	<b>40.000</b>	<b>39.995</b>	<b>0.005</b>	<b>0.006</b>	<b>62.008</b>	<b>62.000</b>	<b>0.000</b>	<b>0.015</b>	<b>62.012</b>	<b>62.007</b>	<b>0.019</b>	<b>0.007</b>
0.024	1.78	1.76	2.28	2.26	1.57480	1.57460	0.00020	0.00025	2.44120	2.44090	0.00000	0.00060	2.44140	2.44120	0.00080	0.00030
<b>0.6</b>	<b>50.7</b>	<b>50.1</b>	<b>63.4</b>	<b>62.9</b>	<b>45.000</b>	<b>44.995</b>	<b>0.005</b>	<b>0.006</b>	<b>68.008</b>	<b>68.000</b>	<b>0.000</b>	<b>0.015</b>	<b>68.012</b>	<b>68.007</b>	<b>0.019</b>	<b>0.007</b>
0.024	1.99	1.97	2.50	2.48	1.77170	1.77150	0.00020	0.00025	2.67750	2.67720	0.00000	0.00060	2.67770	2.67750	0.00080	0.00030
<b>0.6</b>	<b>55.1</b>	<b>54.6</b>	<b>67.9</b>	<b>67.4</b>	<b>50.000</b>	<b>49.995</b>	<b>0.005</b>	<b>0.006</b>	<b>72.008</b>	<b>72.000</b>	<b>0.000</b>	<b>0.015</b>	<b>72.011</b>	<b>72.007</b>	<b>0.019</b>	<b>0.007</b>
0.024	2.17	2.15	2.67	2.65	1.96850	1.96830	0.00020	0.00025	2.83490	2.83460	0.00000	0.00060	2.83510	2.83490	0.00080	0.00030
<b>1.0</b>	<b>60.9</b>	<b>60.4</b>	<b>75.2</b>	<b>74.7</b>	<b>55.000</b>	<b>54.995</b>	<b>0.005</b>	<b>0.007</b>	<b>80.008</b>	<b>80.000</b>	<b>0.000</b>	<b>0.015</b>	<b>80.012</b>	<b>80.008</b>	<b>0.020</b>	<b>0.008</b>
0.039	2.40	2.38	2.96	2.94	2.16540	2.16520	0.00020	0.00030	3.14990	3.14960	0.00000	0.00060	3.15010	3.14990	0.00080	0.00030
<b>1.0</b>	<b>65.8</b>	<b>65.3</b>	<b>80.2</b>	<b>79.7</b>	<b>60.000</b>	<b>59.995</b>	<b>0.005</b>	<b>0.007</b>	<b>85.008</b>	<b>85.000</b>	<b>0.000</b>	<b>0.016</b>	<b>85.016</b>	<b>85.009</b>	<b>0.024</b>	<b>0.009</b>
0.039	2.59	2.57	3.16	3.14	2.36220	2.36200	0.00020	0.00030	3.34680	3.34650	0.00000	0.00060	3.34710	3.34680	0.00090	0.00030
<b>1.0</b>	<b>70.8</b>	<b>70.3</b>	<b>85.2</b>	<b>84.7</b>	<b>65.000</b>	<b>64.995</b>	<b>0.005</b>	<b>0.007</b>	<b>90.008</b>	<b>90.000</b>	<b>0.000</b>	<b>0.016</b>	<b>90.015</b>	<b>90.007</b>	<b>0.023</b>	<b>0.007</b>
0.039	2.79	2.77	3.35	3.33	2.55910	2.55890	0.00020	0.00030	3.54360	3.54330	0.00000	0.00060	3.54390	3.54360	0.00090	0.00030
<b>1.0</b>	<b>76.8</b>	<b>76.3</b>	<b>94.3</b>	<b>93.8</b>	<b>70.000</b>	<b>69.995</b>	<b>0.005</b>	<b>0.007</b>	<b>100.008</b>	<b>100.000</b>	<b>0.000</b>	<b>0.016</b>	<b>100.018</b>	<b>100.010</b>	<b>0.025</b>	<b>0.010</b>

*Continued on next page.*

**ULTRA-LIGHT ISO 19 SERIES - continued**  
**2(3)MV/MM9300WI (71900C(E)-...-P4/P4S)**  
**HIGH PRECISION MV**

Running accuracy, performance and dimensional controls conform to ABEC 7 (ISO P4) requirements.

**SUPER PRECISION MM**

Running accuracy and performance meet ABEC 9 (ISO P2) levels. Other features conform to ABEC 7 (ISO P4) requirements.

**WI CONSTRUCTION**

- Incorporates low shoulder on non-thrust side of outer rings.
- Balls separated by one-piece cage piloted against a ground thrust shoulder land of the outer ring.

Bearing Number 15° C/2 <sup>(3)</sup> or 25° E/3 <sup>(4)</sup>	d Bore	D O.D.	C Width <sup>(1)</sup>	Ball Qty. x Dia.	Bearing Wt.	15° (C/2) Load Ratings						25° (E/3) Load Ratings					
						Steel Ball			Ceramic Ball			Steel Ball			Ceramic Ball		
						C <sub>0</sub> Static	C <sub>e</sub> Dynamic	Speed Rating <sup>(N<sub>g</sub>)</sup>	C <sub>0</sub> Static	C <sub>e</sub> Dynamic	Speed Rating <sup>(N<sub>g</sub>)</sup>	C <sub>0</sub> Static	C <sub>e</sub> Dynamic	Speed Rating <sup>(N<sub>g</sub>)</sup>	C <sub>0</sub> Static	C <sub>e</sub> Dynamic	Speed Rating <sup>(N<sub>g</sub>)</sup>
mm in.	mm in.	mm in.	mm in.	kg lbs.	N lbs.	N lbs.	RPM	N lbs.	N lbs.	RPM	N lbs.	N lbs.	RPM	N lbs.	N lbs.	RPM	
71914	2.7559	3.9370	0.6299	24 x 1 <sup>1</sup> / <sub>32</sub>	0.76	6510	7200	13100	5800	7200	15720	6130	6790	11800	5450	6790	14160
9315WI	<b>75</b>	<b>105</b>	<b>16</b>	<b>25 x 8.7</b>	<b>0.360</b>	<b>30300</b>	<b>32500</b>	<b>12300</b>	<b>26900</b>	<b>32500</b>	<b>14760</b>	<b>28400</b>	<b>30600</b>	<b>11100</b>	<b>25200</b>	<b>30600</b>	<b>13320</b>
71915	2.9528	4.1339	0.6299	25 x 1 <sup>1</sup> / <sub>32</sub>	0.80	6810	7310	12300	6060	7310	14760	6380	6890	11100	5670	6890	13320
9316WI	<b>80</b>	<b>110</b>	<b>16</b>	<b>27 x 8.7</b>	<b>0.390</b>	<b>32700</b>	<b>33800</b>	<b>11600</b>	<b>29100</b>	<b>33800</b>	<b>13920</b>	<b>30500</b>	<b>31900</b>	<b>10400</b>	<b>27100</b>	<b>31900</b>	<b>12500</b>
71916	3.1496	4.3307	0.6299	27 x 1 <sup>1</sup> / <sub>32</sub>	0.85	7350	7600	11600	6540	7600	13920	6860	7170	10400	6100	7170	12500
9317WI	<b>85</b>	<b>120</b>	<b>18</b>	<b>26 x 9.5</b>	<b>0.560</b>	<b>37500</b>	<b>38700</b>	<b>10800</b>	<b>33400</b>	<b>38700</b>	<b>12960</b>	<b>35000</b>	<b>36500</b>	<b>9700</b>	<b>31200</b>	<b>36500</b>	<b>11640</b>
71917	3.3465	4.7244	0.7087	26 x 3 <sup>7</sup> / <sub>8</sub>	1.23	8440	8700	10800	7510	8700	12960	7880	8200	9700	7010	8200	11640
9318WI	<b>90</b>	<b>125</b>	<b>18</b>	<b>26 x 10.3</b>	<b>0.570</b>	<b>44000</b>	<b>45000</b>	<b>10300</b>	<b>39200</b>	<b>45000</b>	<b>12360</b>	<b>41200</b>	<b>42400</b>	<b>9300</b>	<b>36700</b>	<b>42400</b>	<b>11160</b>
71918	3.5433	4.9213	0.7087	26 x 1 <sup>1</sup> / <sub>32</sub>	1.26	9900	10100	10300	8810	10100	12360	9270	9540	9300	8250	9540	11160
9319WI	<b>95</b>	<b>130</b>	<b>18</b>	<b>28 x 10.3</b>	<b>0.600</b>	<b>47400</b>	<b>46800</b>	<b>9800</b>	<b>42200</b>	<b>46800</b>	<b>11760</b>	<b>44200</b>	<b>44100</b>	<b>8800</b>	<b>39300</b>	<b>44100</b>	<b>10560</b>
71919	3.7402	5.1181	0.7087	28 x 1 <sup>1</sup> / <sub>32</sub>	1.33	10700	10500	9800	9480	10500	11760	9930	9910	8800	8840	9910	10560
9320WI	<b>100</b>	<b>140</b>	<b>20</b>	<b>29 x 10.3</b>	<b>0.850</b>	<b>48800</b>	<b>47200</b>	<b>9100</b>	<b>43400</b>	<b>47200</b>	<b>10920</b>	<b>45500</b>	<b>44400</b>	<b>8200</b>	<b>40500</b>	<b>44400</b>	<b>9840</b>
71920	3.9370	5.5118	0.7874	29 x 1 <sup>1</sup> / <sub>32</sub>	1.87	11000	10600	9100	9760	10600	10920	10200	9900	8200	9100	9900	9840
9322WI	<b>110</b>	<b>150</b>	<b>20</b>	<b>31 x 10.3</b>	<b>0.920</b>	<b>51700</b>	<b>48400</b>	<b>8400</b>	<b>46000</b>	<b>48400</b>	<b>10080</b>	<b>48200</b>	<b>45600</b>	<b>7600</b>	<b>42900</b>	<b>45600</b>	<b>9120</b>
71922	4.3307	5.9055	0.7874	31 x 1 <sup>1</sup> / <sub>32</sub>	2.02	11600	10900	8400	10300	10900	10080	10800	10200	7600	9650	10200	9120
9324WI	<b>120</b>	<b>165</b>	<b>22</b>	<b>30 x 11.9</b>	<b>1.240</b>	<b>66900</b>	<b>62000</b>	<b>7700</b>	<b>59500</b>	<b>62000</b>	<b>9240</b>	<b>62300</b>	<b>58300</b>	<b>6900</b>	<b>55500</b>	<b>58300</b>	<b>8300</b>
71924	4.7244	6.4961	0.8661	30 x 1 <sup>1</sup> / <sub>32</sub>	2.74	15000	13900	7700	13400	13900	9240	14000	13100	6900	12500	13100	8300
9326WI	<b>130</b>	<b>180</b>	<b>24</b>	<b>30 x 13.5</b>	<b>1.650</b>	<b>86400</b>	<b>78500</b>	<b>7100</b>	<b>76900</b>	<b>78500</b>	<b>8520</b>	<b>80500</b>	<b>73900</b>	<b>6400</b>	<b>71700</b>	<b>73900</b>	<b>7700</b>
71926	5.1181	7.0866	0.9449	30 x 1 <sup>1</sup> / <sub>32</sub>	3.63	19400	17600	7100	17300	17600	8520	18100	16600	6400	16100	16600	7700
9328WI	<b>140</b>	<b>190</b>	<b>24</b>	<b>32 x 13.5</b>	<b>1.750</b>	<b>91600</b>	<b>80700</b>	<b>6600</b>	<b>81500</b>	<b>80700</b>	<b>7920</b>	<b>85400</b>	<b>76000</b>	<b>5900</b>	<b>76000</b>	<b>76000</b>	<b>7080</b>
71928	5.5118	7.4803	0.9449	32 x 1 <sup>1</sup> / <sub>32</sub>	3.85	20600	18200	6600	18300	18200	7920	19200	17100	5900	17100	17100	7080
9330WI	<b>150</b>	<b>210</b>	<b>28</b>	<b>27 x 17.5</b>	<b>2.610</b>	<b>130800</b>	<b>119200</b>	<b>6200</b>	<b>116400</b>	<b>119200</b>	<b>7440</b>	<b>122700</b>	<b>112400</b>	<b>5600</b>	<b>109200</b>	<b>112400</b>	<b>6700</b>
71930	5.9055	8.2677	1.1024	27 x 1 <sup>1</sup> / <sub>16</sub>	5.75	29400	26800	6200	26200	26800	7440	27600	25300	5600	24500	25300	6720
9332WI	<b>160</b>	<b>220</b>	<b>28</b>	<b>27 x 18.3</b>	<b>2.750</b>	<b>143100</b>	<b>128900</b>	<b>5800</b>	<b>127300</b>	<b>128900</b>	<b>6960</b>	<b>134100</b>	<b>121600</b>	<b>5800</b>	<b>119300</b>	<b>121600</b>	<b>6690</b>
71932	6.2992	8.6614	1.1024	27 x 2 <sup>3</sup> / <sub>32</sub>	6.06	32200	29000	5800	28600	29000	6960	30100	27300	5800	26800	27300	6960
9334WI	<b>170</b>	<b>230</b>	<b>28</b>	<b>29 x 18.3</b>	<b>2.880</b>	<b>153600</b>	<b>133700</b>	<b>5500</b>	<b>136700</b>	<b>133700</b>	<b>6600</b>	<b>143200</b>	<b>126000</b>	<b>5000</b>	<b>127500</b>	<b>126000</b>	<b>6000</b>
71934	6.6929	9.0551	1.1024	29 x 2 <sup>3</sup> / <sub>32</sub>	6.34	34500	30100	5500	30700	30100	6600	32200	28300	5000	28700	28300	6000
9340WI	<b>200</b>	<b>280</b>	<b>38</b>	<b>27 x 23.8</b>	<b>6.290</b>	<b>243300</b>	<b>209400</b>	<b>4600</b>	<b>216300</b>	<b>209400</b>	<b>5520</b>	<b>228800</b>	<b>197500</b>	<b>4100</b>	<b>203600</b>	<b>197700</b>	<b>4920</b>
71940	7.8740	11.0236	1.4961	27 x 1 <sup>1</sup> / <sub>16</sub>	13.87	54600	47100	4600	48600	47100	5520	51400	44400	4100	45800	44400	4920

<sup>(N<sub>g</sub>)</sup>For a single, grease-lubricated, spring-preloaded bearing. This value to be used in permissible operating speed (Sp) calculation.

<sup>(1)</sup>Width tolerance of preloaded bearing set +0.000/-0.254 mm (+0.0000/-0.0100 in.).

<sup>(2)</sup>Fill weights based upon specific gravity of 0.99.

<sup>(3)</sup>C is ISO designation for 15° contact angle, 2 is Timken designation for 15° contact angle.

<sup>(4)</sup>E is ISO designation for 25° contact angle, 3 is Timken designation for 25° contact angle.

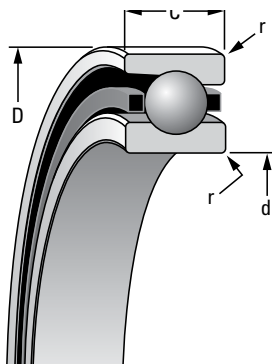

r Rad. <sup>(2)</sup>	Suggested Shoulder Diameters				Shaft Diameter		Mounting Fits		Fixed				Floating			
	Shaft		Housing						Housing Bore (Stationary)		Mounting Fits		Housing Bore (Stationary)		Mounting Fits	
	Max.	Min.	Max.	Min.					Max.	Min.	Tight	Loose	Max.	Min.	Loose	Loose
mm in.	mm in.	mm in.	mm in.	mm in.	mm in.	mm in.	mm in.	mm in.	mm in.	mm in.	mm in.	mm in.	mm in.	mm in.	mm in.	
0.039	3.02	3.00	3.71	3.69	2.75590	2.75570	0.00020	0.00030	3.93730	3.93700	0.00000	0.00060	3.93770	3.93740	0.00100	0.00040
<b>1.0</b>	<b>81.9</b>	<b>81.1</b>	<b>99.4</b>	<b>98.6</b>	<b>75.005</b>	<b>74.995</b>	<b>0.005</b>	<b>0.012</b>	<b>105.008</b>	<b>105.000</b>	<b>0.000</b>	<b>0.016</b>	<b>105.019</b>	<b>105.011</b>	<b>0.026</b>	<b>0.011</b>
0.039	3.22	3.19	3.91	3.88	2.95300	2.95260	0.00020	0.00050	4.13420	4.13390	0.00000	0.00060	4.13460	4.13430	0.00100	0.00040
<b>1.0</b>	<b>86.9</b>	<b>86.1</b>	<b>104.4</b>	<b>103.6</b>	<b>80.005</b>	<b>79.995</b>	<b>0.005</b>	<b>0.012</b>	<b>110.008</b>	<b>110.000</b>	<b>0.000</b>	<b>0.016</b>	<b>110.018</b>	<b>110.010</b>	<b>0.025</b>	<b>0.010</b>
0.039	3.42	3.39	4.11	4.08	3.14980	3.14940	0.00020	0.00050	4.33100	4.33070	0.00000	0.00060	4.33140	4.33110	0.00100	0.00040
<b>1.0</b>	<b>93.6</b>	<b>92.8</b>	<b>112.7</b>	<b>111.9</b>	<b>85.005</b>	<b>84.995</b>	<b>0.005</b>	<b>0.012</b>	<b>120.008</b>	<b>120.000</b>	<b>0.000</b>	<b>0.016</b>	<b>120.018</b>	<b>120.010</b>	<b>0.025</b>	<b>0.010</b>
0.039	3.69	3.66	4.44	4.41	3.34670	3.34630	0.00020	0.00050	4.72470	4.72440	0.00000	0.00060	4.72510	4.72480	0.00100	0.00040
<b>1.0</b>	<b>97.8</b>	<b>97.0</b>	<b>118.5</b>	<b>117.7</b>	<b>90.005</b>	<b>89.995</b>	<b>0.005</b>	<b>0.013</b>	<b>125.008</b>	<b>125.000</b>	<b>0.000</b>	<b>0.017</b>	<b>125.021</b>	<b>125.011</b>	<b>0.030</b>	<b>0.011</b>
0.039	3.85	3.82	4.66	4.63	3.54350	3.54310	0.00020	0.00050	4.92160	4.92130	0.00000	0.00070	4.92210	4.92170	0.00120	0.00040
<b>1.0</b>	<b>102.8</b>	<b>102.0</b>	<b>123.5</b>	<b>122.7</b>	<b>95.005</b>	<b>94.995</b>	<b>0.005</b>	<b>0.013</b>	<b>130.009</b>	<b>130.000</b>	<b>0.000</b>	<b>0.018</b>	<b>130.020</b>	<b>130.010</b>	<b>0.029</b>	<b>0.010</b>
0.039	4.05	4.02	4.86	4.83	3.74040	3.74000	0.00020	0.00050	5.11850	5.11810	0.00000	0.00070	5.11890	5.11850	0.00110	0.00040
<b>1.0</b>	<b>110.3</b>	<b>109.5</b>	<b>131.0</b>	<b>130.2</b>	<b>100.005</b>	<b>99.995</b>	<b>0.005</b>	<b>0.013</b>	<b>140.009</b>	<b>140.000</b>	<b>0.000</b>	<b>0.018</b>	<b>140.020</b>	<b>140.010</b>	<b>0.029</b>	<b>0.010</b>
0.039	4.34	4.31	5.16	5.13	3.93720	3.93680	0.00020	0.00050	5.51220	5.51180	0.00000	0.00070	5.51260	5.51220	0.00110	0.00040
<b>1.0</b>	<b>120.3</b>	<b>119.5</b>	<b>141.0</b>	<b>140.2</b>	<b>110.005</b>	<b>109.995</b>	<b>0.005</b>	<b>0.013</b>	<b>150.009</b>	<b>150.000</b>	<b>0.000</b>	<b>0.018</b>	<b>150.023</b>	<b>150.012</b>	<b>0.032</b>	<b>0.012</b>
0.039	4.74	4.71	5.55	5.52	4.33090	4.33050	0.00020	0.00050	5.90590	5.90550	0.00000	0.00070	5.90640	5.90600	0.00120	0.00050
<b>1.0</b>	<b>131.2</b>	<b>130.4</b>	<b>155.0</b>	<b>154.3</b>	<b>120.005</b>	<b>119.995</b>	<b>0.005</b>	<b>0.013</b>	<b>165.010</b>	<b>165.000</b>	<b>0.000</b>	<b>0.020</b>	<b>165.022</b>	<b>165.012</b>	<b>0.032</b>	<b>0.012</b>
0.039	5.16	5.13	6.10	6.07	4.72460	4.72420	0.00020	0.00050	6.49650	6.49610	0.00000	0.00080	6.49700	6.49660	0.00130	0.00050
<b>1.5</b>	<b>142.1</b>	<b>141.4</b>	<b>169.2</b>	<b>168.4</b>	<b>130.005</b>	<b>129.995</b>	<b>0.005</b>	<b>0.015</b>	<b>180.010</b>	<b>180.000</b>	<b>0.000</b>	<b>0.020</b>	<b>180.022</b>	<b>180.012</b>	<b>0.032</b>	<b>0.012</b>
0.059	5.60	5.57	6.66	6.63	5.11830	5.11790	0.00020	0.00060	7.08700	7.08660	0.00000	0.00080	7.08750	7.08710	0.00130	0.00050
<b>1.5</b>	<b>152.1</b>	<b>151.4</b>	<b>179.2</b>	<b>178.4</b>	<b>140.005</b>	<b>139.995</b>	<b>0.005</b>	<b>0.015</b>	<b>190.010</b>	<b>190.000</b>	<b>0.000</b>	<b>0.021</b>	<b>190.022</b>	<b>190.012</b>	<b>0.033</b>	<b>0.012</b>
0.059	5.99	5.96	7.05	7.02	5.51200	5.51160	0.00020	0.00060	7.48070	7.48030	0.00000	0.00080	7.48120	7.48080	0.00140	0.00050
<b>2.0</b>	<b>163.1</b>	<b>162.4</b>	<b>198.2</b>	<b>197.4</b>	<b>150.005</b>	<b>149.995</b>	<b>0.005</b>	<b>0.015</b>	<b>210.011</b>	<b>210.000</b>	<b>0.000</b>	<b>0.022</b>	<b>210.025</b>	<b>210.015</b>	<b>0.036</b>	<b>0.015</b>
0.079	6.42	6.39	7.80	7.77	5.90570	5.90530	0.00020	0.00060	8.26820	8.26770	0.00000	0.00090	8.26870	8.26830	0.00150	0.00060
<b>2.0</b>	<b>173.2</b>	<b>172.4</b>	<b>208.2</b>	<b>207.4</b>	<b>160.005</b>	<b>159.995</b>	<b>0.005</b>	<b>0.015</b>	<b>220.011</b>	<b>220.000</b>	<b>0.000</b>	<b>0.022</b>	<b>220.025</b>	<b>220.015</b>	<b>0.036</b>	<b>0.015</b>
0.079	6.82	6.79	8.20	8.17	6.29940	6.29900	0.00020	0.00060	8.66190	8.66140	0.00000	0.00090	8.66240	8.66200	0.00150	0.00060
<b>2.0</b>	<b>185.4</b>	<b>184.7</b>	<b>216.1</b>	<b>215.4</b>	<b>170.005</b>	<b>169.995</b>	<b>0.005</b>	<b>0.015</b>	<b>230.011</b>	<b>230.000</b>	<b>0.000</b>	<b>0.022</b>	<b>230.025</b>	<b>230.015</b>	<b>0.036</b>	<b>0.015</b>
0.079	7.30	7.27	8.51	8.48	6.69310	6.69270	0.00020	0.00060	9.05560	9.05510	0.00000	0.00090	9.05610	9.05570	0.00150	0.00060
<b>2.1</b>	<b>216.8</b>	<b>216.0</b>	<b>264.5</b>	<b>263.7</b>	<b>200.008</b>	<b>199.993</b>	<b>0.007</b>	<b>0.019</b>	<b>280.013</b>	<b>280.000</b>	<b>0.000</b>	<b>0.026</b>	<b>280.031</b>	<b>280.018</b>	<b>0.044</b>	<b>0.018</b>
0.083	8.54	8.51	10.41	10.38	7.87430	7.87370	0.00030	0.00080	11.02410	11.02360	0.00000	0.00100	11.02490	11.02440	0.00180	0.00080

**ULTRA-LIGHT ISO 19 SERIES**  
**2MV/MM9300WI (71900E-...-P4/P4S)**  
**DUPLEX PERFORMANCE DATA**

Bearing Number	Preload				Axial Stiffness <sup>(1)</sup>				Radial Stiffness <sup>(1)</sup>				Spacer Offsets <sup>(1)</sup>		
	DUX X-light	DUL Light	DUM Med.	DUH Heavy	X-light	Light	Med.	Heavy	X-light	Light	Med.	Heavy	X-light to Light	Light to Med.	Med. to Heavy
	N lbs.	N lbs.	N lbs.	N lbs.	N/μm 10 <sup>6</sup> lbs./in.	N/μm 10 <sup>6</sup> lbs./in.	N/μm 10 <sup>6</sup> lbs./in.	N/μm 10 <sup>6</sup> lbs./in.	N/μm 10 <sup>6</sup> lbs./in.	N/μm 10 <sup>6</sup> lbs./in.	N/μm 10 <sup>6</sup> lbs./in.	N/μm 10 <sup>6</sup> lbs./in.	μm in.	μm in.	μm in.
2MV/MM9300WICR	—	15	25	55	14.17	16.44	21.69	29.21	—	73.11	92.17	115.43	1.30	2.80	4.10
71900C-T-P4/P4S	—	3	6	12	0.081	0.094	0.124	0.167	—	0.418	0.527	0.660	0.00005	0.00011	0.00016
2MV/MM9301WICR	—	15	25	55	14.87	17.32	22.74	30.61	—	76.96	97.42	121.91	1.00	2.50	4.10
71901C-T-P4/P4S	—	3	6	12	0.085	0.099	0.130	0.175	—	0.440	0.557	0.697	0.00004	0.00010	0.00016
2MV/MM9302WICR	—	20	45	90	16.44	20.11	26.76	36.55	—	98.12	123.30	153.91	2.00	3.80	5.60
71902C-T-P4/P4S	—	5	10	20	0.094	0.115	0.153	0.209	—	0.561	0.705	0.880	0.00008	0.00015	0.00022
2MV/MM9303WICR	—	20	65	130	17.84	21.86	34.63	47.75	—	107.91	154.96	192.74	1.80	6.40	6.40
71903C-T-P4/P4S	—	5	15	30	0.102	0.125	0.198	0.273	—	0.617	0.886	1.102	0.00007	0.00025	0.00025
2MV/MM9304WICR	—	45	90	160	18.19	26.41	35.68	46.17	—	148.32	186.09	222.47	4.80	5.80	6.60
71904C-T-P4/P4S	—	10	20	35	0.104	0.151	0.204	0.264	—	0.848	1.064	1.272	0.00019	0.00023	0.00026
2MV/MM9305WICR	—	45	110	180	20.64	29.56	43.90	54.57	—	168.78	228.24	265.15	4.30	7.40	5.30
71905C-T-P4/P4S	—	10	25	40	0.118	0.169	0.251	0.312	—	0.965	1.305	1.516	0.00017	0.00029	0.00021
2MV/MM9306WICR	—	45	110	180	22.04	31.48	46.52	57.89	—	181.55	246.08	286.14	4.10	6.90	5.10
71906C-T-P4/P4S	—	10	25	40	0.126	0.180	0.266	0.331	—	1.038	1.407	1.636	0.00016	0.00027	0.00020
2MV/MM9307WICR	—	45	110	240	25.36	33.06	48.27	68.74	—	189.42	258.68	333.53	3.00	6.60	9.10
71907C-T-P4/P4S	—	10	25	55	0.145	0.189	0.276	0.393	—	1.083	1.479	1.907	0.00012	0.00026	0.00036
2MV/MM9308WICR	30	65	160	310	27.28	39.00	55.44	76.08	146.16	229.12	304.68	380.76	4.80	7.60	9.40
71908C-T-P4/P4S	5	15	35	70	0.156	0.223	0.317	0.435	0.835	1.310	1.742	2.177	0.00019	0.00030	0.00037
2MV/MM9309WICR	30	90	180	360	36.53	46.35	62.26	85.35	208.32	270.22	340.18	425.53	5.80	6.60	9.70
71909C-T-P4/P4S	10	20	40	80	0.209	0.265	0.356	0.488	1.190	1.545	1.945	2.433	0.00023	0.00026	0.00038
2MV/MM9310WICR	40	90	200	400	34.28	48.97	68.91	94.80	219.83	286.84	376.21	469.96	5.10	7.60	9.70
71910C-T-P4/P4S	10	20	45	90	0.196	0.280	0.394	0.542	1.255	1.640	2.151	2.687	0.0002	0.00030	0.00038
2MV/MM9311WICR	40	110	240	490	38.83	55.27	76.96	105.46	222.62	320.24	416.96	521.03	5.60	8.10	10.70
71911C-T-P4/P4S	10	25	55	110	0.222	0.316	0.440	0.603	1.271	1.831	2.384	2.979	0.00022	0.00032	0.00042
2MV/MM9312WICR	40	110	240	510	43.73	58.24	80.63	112.64	233.31	338.08	441.10	559.51	4.60	7.60	10.90
71912C-T-P4/P4S	10	25	55	115	0.250	0.333	0.461	0.644	1.332	1.933	2.522	3.199	0.00018	0.00030	0.00043
2MV/MM9313WICR	70	130	270	530	50.02	65.59	87.62	119.63	290.72	378.83	478.00	597.63	4.60	6.90	10.40
71913C-T-P4/P4S	15	30	60	120	0.286	0.375	0.501	0.684	1.660	2.166	2.733	3.417	0.00018	0.00027	0.00041
2MV/MM9314WICR	70	180	360	710	49.67	69.44	93.05	127.50	283.26	416.61	525.40	656.75	6.90	8.60	13.00
71914C-T-P4/P4S	15	40	80	160	0.284	0.397	0.532	0.729	1.618	2.382	3.004	3.755	0.00027	0.00034	0.00051

<sup>(1)</sup>For DB or DF arrangements only. For other mounting arrangements, contact your Timken representative.

**MOUNTING ARRANGEMENTS**

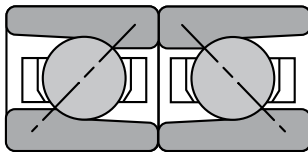

**Back-to-Back  
DB**

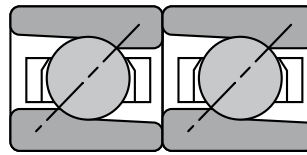

**Tandem  
DT**

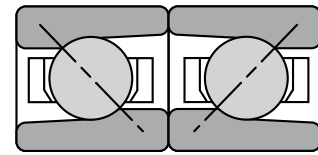

**Face-to-Face  
DF**

Bearing Number	Preload				Axial Stiffness <sup>(1)</sup>				Radial Stiffness <sup>(1)</sup>				Spacer Offsets <sup>(1)</sup>		
	DUX X-light	DUL Light	DUM Med.	DUH Heavy	X-light	Light	Med.	Heavy	X-light	Light	Med.	Heavy	X-light to Light	Light to Med.	Med. to Heavy
	<b>N</b> lbs.	<b>N</b> lbs.	<b>N</b> lbs.	<b>N</b> lbs.	<b>N/μm</b> 10 <sup>6</sup> lbs./in.	<b>N/μm</b> 10 <sup>6</sup> lbs./in.	<b>N/μm</b> 10 <sup>6</sup> lbs./in.	<b>N/μm</b> 10 <sup>6</sup> lbs./in.	<b>N/μm</b> 10 <sup>6</sup> lbs./in.	<b>N/μm</b> 10 <sup>6</sup> lbs./in.	<b>N/μm</b> 10 <sup>6</sup> lbs./in.	<b>N/μm</b> 10 <sup>6</sup> lbs./in.	<b>μm</b> in.	<b>μm</b> in.	<b>μm</b> in.
2MV/MM9315WICR	<b>90</b>	<b>180</b>	<b>380</b>	<b>760</b>	<b>53.17</b>	<b>71.18</b>	<b>97.77</b>	<b>134.15</b>	<b>328.58</b>	<b>427.81</b>	<b>550.94</b>	<b>688.58</b>	<b>6.10</b>	<b>9.40</b>	<b>13.00</b>
71915C-T-P4/P4S	20	40	85	170	0.304	0.407	0.559	0.767	1.876	2.446	3.150	3.937	0.00024	0.00037	0.00051
2MV/MM9316WICR	<b>90</b>	<b>200</b>	<b>400</b>	<b>800</b>	<b>57.89</b>	<b>78.18</b>	<b>104.59</b>	<b>143.59</b>	<b>340.07</b>	<b>468.73</b>	<b>591.16</b>	<b>738.95</b>	<b>6.40</b>	<b>8.60</b>	<b>13.00</b>
71916C-T-P4/P4S	20	45	90	180	0.331	0.447	0.598	0.821	1.942	2.680	3.380	4.225	0.00042	0.00034	0.00051
2MV/MM9317WICR	<b>110</b>	<b>270</b>	<b>530</b>	<b>1070</b>	<b>61.39</b>	<b>85.88</b>	<b>115.78</b>	<b>160.03</b>	<b>373.23</b>	<b>521.20</b>	<b>655.00</b>	<b>817.48</b>	<b>8.10</b>	<b>10.70</b>	<b>15.50</b>
71917C-T-P4/P4S	25	60	120	240	0.351	0.491	0.662	0.915	2.131	2.980	3.745	4.674	0.00032	0.00042	0.00061
2MV/MM9318WICR	<b>110</b>	<b>270</b>	<b>530</b>	<b>1070</b>	<b>65.06</b>	<b>90.25</b>	<b>120.51</b>	<b>164.93</b>	<b>379.27</b>	<b>528.37</b>	<b>666.72</b>	<b>833.75</b>	<b>7.90</b>	<b>10.20</b>	<b>15.00</b>
71918C-T-P4/P4S	25	60	120	240	0.372	0.516	0.689	0.943	2.166	3.021	3.812	4.767	0.00031	0.00040	0.00059
2MV/MM9319WICR	<b>130</b>	<b>290</b>	<b>580</b>	<b>1160</b>	<b>70.13</b>	<b>97.42</b>	<b>130.13</b>	<b>178.05</b>	<b>428.12</b>	<b>570.17</b>	<b>719.36</b>	<b>899.51</b>	<b>7.90</b>	<b>10.20</b>	<b>15.00</b>
71919C-T-P4/P4S	30	65	130	260	0.401	0.557	0.744	1.018	2.445	3.260	4.113	5.143	0.00031	0.00040	0.00059
2MV/MM9320WICR	<b>130</b>	<b>360</b>	<b>710</b>	<b>1470</b>	<b>75.38</b>	<b>108.26</b>	<b>145.52</b>	<b>203.23</b>	<b>436.73</b>	<b>626.49</b>	<b>788.27</b>	<b>993.43</b>	<b>9.10</b>	<b>11.20</b>	<b>17.30</b>
71920C-T-P4/P4S	30	80	160	330	0.431	0.619	0.832	1.162	2.494	3.582	4.507	5.680	0.00036	0.00044	0.00068
2MV/MM9322WICR	<b>180</b>	<b>400</b>	<b>800</b>	<b>1600</b>	<b>88.15</b>	<b>125.75</b>	<b>169.48</b>	<b>234.19</b>	<b>511.47</b>	<b>681.41</b>	<b>856.84</b>	<b>1068.81</b>	<b>9.10</b>	<b>11.40</b>	<b>17.00</b>
71922C-T-P4/P4S	40	90	180	360	0.504	0.719	0.969	1.339	2.921	3.896	4.899	6.111	0.00036	0.00045	0.00067
2MV/MM9324WICR	<b>200</b>	<b>490</b>	<b>980</b>	<b>1960</b>	<b>91.81</b>	<b>130.59</b>	<b>175.36</b>	<b>241.16</b>	<b>537.94</b>	<b>752.94</b>	<b>947.08</b>	<b>1181.97</b>	<b>10.70</b>	<b>13.20</b>	<b>19.30</b>
71924C-T-P4/P4S	45	110	220	440	0.524	0.746	1.001	1.377	3.072	4.305	5.415	6.758	0.00042	0.00052	0.00076
2MV/MM9326WICR	<b>220</b>	<b>620</b>	<b>1220</b>	<b>2450</b>	<b>106.69</b>	<b>150.06</b>	<b>201.48</b>	<b>280.36</b>	<b>577.30</b>	<b>846.52</b>	<b>1058.84</b>	<b>1322.07</b>	<b>13.00</b>	<b>14.20</b>	<b>21.30</b>
71926C-T-P4/P4S	50	140	275	550	0.610	0.858	1.152	1.603	3.297	4.840	6.054	7.559	0.00051	0.00056	0.00084
2MV/MM9328WICR	<b>270</b>	<b>620</b>	<b>1250</b>	<b>2560</b>	<b>105.11</b>	<b>159.68</b>	<b>214.43</b>	<b>297.33</b>	<b>648.08</b>	<b>883.59</b>	<b>1112.54</b>	<b>1401.30</b>	<b>11.20</b>	<b>14.20</b>	<b>21.80</b>
71928C-T-P4/P4S	60	140	280	575	0.601	0.913	1.226	1.700	3.701	5.052	6.361	8.012	0.00044	0.00056	0.00086
2MV/MM9330WICR	<b>290</b>	<b>850</b>	<b>1690</b>	<b>3450</b>	<b>107.62</b>	<b>163.29</b>	<b>218.65</b>	<b>302.49</b>	<b>626.95</b>	<b>954.95</b>	<b>1203.31</b>	<b>1512.71</b>	<b>16.80</b>	<b>18.00</b>	<b>27.40</b>
71930C-T-P4/P4S	65	190	380	775	0.615	0.932	1.249	1.727	3.580	5.460	6.880	8.649	0.00066	0.00071	0.00108
2MV/MM9332WICR	<b>489</b>	<b>980</b>	<b>1980</b>	<b>3960</b>	<b>131.90</b>	<b>173.60</b>	<b>234.10</b>	<b>322.10</b>	<b>791.24</b>	<b>1013.50</b>	<b>1281.00</b>	<b>1600.00</b>	<b>12.70</b>	<b>19.80</b>	<b>28.45</b>
71932C-T-P4/P4S	110	220	445	890	0.753	0.991	1.337	1.839	4.518	5.787	7.315	9.135	0.0005	0.00078	0.00112
2MV/MM9334WICR	<b>360</b>	<b>1020</b>	<b>2050</b>	<b>4000</b>	<b>122.06</b>	<b>184.37</b>	<b>247.29</b>	<b>336.09</b>	<b>720.86</b>	<b>1085.95</b>	<b>1367.72</b>	<b>1696.36</b>	<b>17.50</b>	<b>19.30</b>	<b>27.20</b>
71934C-T-P4/P4S	80	230	460	900	0.697	1.053	1.412	1.919	4.116	6.209	7.820	9.699	0.00069	0.00076	0.00107
2MV/MM9340WICR	<b>778</b>	<b>1560</b>	<b>3110</b>	<b>6230</b>	<b>164.93</b>	<b>217.05</b>	<b>291.03</b>	<b>399.82</b>	<b>1006.20</b>	<b>1296.71</b>	<b>1634.27</b>	<b>2042.83</b>	<b>16.30</b>	<b>24.40</b>	<b>36.10</b>
71940C-T-P4/P4S	175	350	700	1400	0.943	1.241	1.664	2.286	5.746	7.414	9.344	11.680	0.00064	0.00096	0.00142

**ULTRA-LIGHT ISO 19 SERIES**  
**3MV/MM9300WI (71900C-...-P4/P4S)**  
**DUPLEX PERFORMANCE DATA**

Bearing Number	Preload				Axial Stiffness <sup>(1)</sup>				Radial Stiffness <sup>(1)</sup>				Spacer Offsets <sup>(1)</sup>		
	DUX X-light	DUL Light	DUM Med.	DUH Heavy	X-light	Light	Med.	Heavy	X-light	Light	Med.	Heavy	X-light to Light	Light to Med.	Med. to Heavy
	N lbs.	N lbs.	N lbs.	N lbs.	N/μm 10 <sup>6</sup> lbs./in.	N/μm 10 <sup>6</sup> lbs./in.	N/μm 10 <sup>6</sup> lbs./in.	N/μm 10 <sup>6</sup> lbs./in.	N/μm 10 <sup>6</sup> lbs./in.	N/μm 10 <sup>6</sup> lbs./in.	N/μm 10 <sup>6</sup> lbs./in.	N/μm 10 <sup>6</sup> lbs./in.	μm in.	μm in.	μm in.
3MV/MM9300WICR	—	<b>20</b>	<b>45</b>	<b>90</b>	—	<b>32.70</b>	<b>42.30</b>	<b>55.30</b>	—	<b>70.50</b>	<b>88.70</b>	<b>110.90</b>	—	<b>2.54</b>	<b>3.81</b>
71900E-T-P4/P4S	—	5	10	20	—	0.187	0.242	0.316	—	0.403	0.507	0.634	—	0.00010	0.00015
3MV/MM9301WICR	—	<b>20</b>	<b>45</b>	<b>90</b>	—	<b>34.50</b>	<b>44.50</b>	<b>58.140</b>	—	<b>74.40</b>	<b>93.70</b>	<b>117.30</b>	—	<b>2.030</b>	<b>3.81</b>
71901E-T-P4/P4S	—	5	10	20	—	0.197	0.254	0.332	—	0.425	0.535	0.670	—	0.00008	0.00015
3MV/MM9302WICR	—	<b>45</b>	<b>90</b>	<b>160</b>	—	<b>46.40</b>	<b>60.20</b>	<b>75.20</b>	—	<b>96.90</b>	<b>121.60</b>	<b>145.20</b>	—	<b>3.30</b>	<b>4.06</b>
71902E-T-P4/P4S	—	10	20	35	—	0.265	0.344	0.430	—	0.554	0.695	0.830	—	0.00013	0.00016
3MV/MM9303WICR	—	<b>45</b>	<b>130</b>	<b>240</b>	—	<b>50.70</b>	<b>77.00</b>	<b>98.60</b>	—	<b>106.50</b>	<b>152.50</b>	<b>184.50</b>	—	<b>5.59</b>	<b>5.08</b>
71903E-T-P4/P4S	—	10	30	55	—	0.290	0.440	0.564	—	0.609	0.872	1.055	—	0.00022	0.00020
3MV/MM9304WICR	—	<b>45</b>	<b>155</b>	<b>265</b>	—	<b>51.80</b>	<b>82.70</b>	<b>102.40</b>	—	<b>112.40</b>	<b>170.60</b>	<b>202.60</b>	—	<b>6.60</b>	<b>5.08</b>
71904E-T-P4/P4S	—	10	35	60	—	0.296	0.472	0.585	—	0.642	0.974	1.157	—	0.00026	0.00020
3MV/MM9305WICR	—	<b>65</b>	<b>180</b>	<b>310</b>	—	<b>67.90</b>	<b>97.90</b>	<b>122.40</b>	—	<b>146.70</b>	<b>202.90</b>	<b>242.80</b>	—	<b>5.33</b>	<b>4.83</b>
71905E-T-P4/P4S	—	15	40	70	—	0.388	0.560	0.700	—	0.839	1.160	1.388	—	0.00021	0.00019
3MV/MM9306WICR	—	<b>70</b>	<b>180</b>	<b>310</b>	—	<b>72.90</b>	<b>105.30</b>	<b>130.70</b>	—	<b>157.80</b>	<b>218.80</b>	<b>262.00</b>	—	<b>5.08</b>	<b>4.57</b>
71906E-T-P4/P4S	—	15	40	70	—	0.417	0.602	0.747	—	0.902	1.251	1.498	—	0.00020	0.00018
3MV/MM9307WICR	<b>45</b>	<b>90</b>	<b>240</b>	<b>420</b>	<b>67.10</b>	<b>84.60</b>	<b>123.30</b>	<b>152.50</b>	<b>141.29</b>	<b>182.80</b>	<b>255.70</b>	<b>304.90</b>	<b>2.32</b>	<b>5.84</b>	<b>5.08</b>
71907E-T-P4/P4S	10	20	55	95	0.383	0.484	0.705	0.872	0.807	1.045	1.462	1.743	0.00009	0.00023	0.00020
3MV/MM9308WICR	<b>65</b>	<b>130</b>	<b>310</b>	<b>560</b>	<b>81.41</b>	<b>101.80</b>	<b>139.40</b>	<b>174.90</b>	<b>169.34</b>	<b>218.80</b>	<b>289.80</b>	<b>349.30</b>	<b>2.87</b>	<b>5.84</b>	<b>6.10</b>
71908E-T-P4/P4S	15	30	70	125	0.465	0.582	0.797	1.000	0.967	1.251	1.657	1.997	0.00011	0.00023	0.00024
3MV/MM9309WICR	<b>90</b>	<b>160</b>	<b>360</b>	<b>670</b>	<b>96.15</b>	<b>114.70</b>	<b>156.20</b>	<b>199.70</b>	<b>200.56</b>	<b>246.30</b>	<b>323.90</b>	<b>396.30</b>	<b>2.49</b>	<b>5.84</b>	<b>6.86</b>
71909E-T-P4/P4S	20	35	80	150	0.549	0.656	0.893	1.142	1.145	1.408	1.852	2.266	0.00010	0.00023	0.00027
3MV/MM9310WICR	<b>90</b>	<b>160</b>	<b>400</b>	<b>670</b>	<b>101.98</b>	<b>121.50</b>	<b>174.60</b>	<b>210.90</b>	<b>212.51</b>	<b>261.50</b>	<b>357.80</b>	<b>419.60</b>	<b>2.35</b>	<b>6.60</b>	<b>5.59</b>
71910E-T-P4/P4S	20	35	90	150	0.582	0.695	0.998	1.206	1.214	1.495	2.046	2.399	0.00009	0.00026	0.00022
3MV/MM9311WICR	<b>90</b>	<b>200</b>	<b>490</b>	<b>850</b>	<b>105.30</b>	<b>138.70</b>	<b>193.80</b>	<b>239.80</b>	<b>218.94</b>	<b>294.50</b>	<b>396.30</b>	<b>472.60</b>	<b>3.60</b>	<b>6.86</b>	<b>6.60</b>
71911E-T-P4/P4S	20	45	110	190	0.601	0.793	1.108	1.371	1.250	1.684	2.266	2.702	0.00014	0.00027	0.00026
3MV/MM9312WICR	<b>90</b>	<b>200</b>	<b>510</b>	<b>890</b>	<b>111.17</b>	<b>146.70</b>	<b>207.60</b>	<b>257.50</b>	<b>230.00</b>	<b>311.10</b>	<b>425.40</b>	<b>508.40</b>	<b>3.41</b>	<b>6.86</b>	<b>6.60</b>
71912E-T-P4/P4S	20	45	115	200	0.635	0.839	1.187	1.472	1.313	1.779	2.432	2.907	0.00013	0.00027	0.00026
3MV/MM9313WICR	<b>110</b>	<b>220</b>	<b>530</b>	<b>1070</b>	<b>126.38</b>	<b>159.70</b>	<b>221.20</b>	<b>290.00</b>	<b>263.42</b>	<b>339.30</b>	<b>454.40</b>	<b>599.20</b>	<b>3.08</b>	<b>6.60</b>	<b>8.38</b>
71913E-T-P4/P4S	25	50	120	240	0.722	0.913	1.265	1.658	1.504	1.940	2.598	3.426	0.00012	0.00026	0.00033
3MV/MM9314WICR	<b>130</b>	<b>290</b>	<b>710</b>	<b>1290</b>	<b>131.95</b>	<b>171.60</b>	<b>239.40</b>	<b>301.70</b>	<b>275.56</b>	<b>366.40</b>	<b>494.80</b>	<b>599.20</b>	<b>4.06</b>	<b>8.13</b>	<b>8.64</b>
71914E-T-P4/P4S	30	65	160	290	0.753	0.981	1.369	1.725	1.574	2.095	2.829	3.426	0.00016	0.00032	0.00034

<sup>(1)</sup>For DB or DF arrangements only. For other mounting arrangements, contact your Timken representative.

**MOUNTING ARRANGEMENTS**

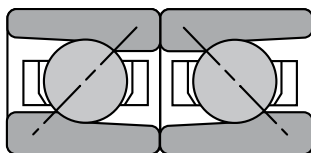

**Back-to-Back  
DB**

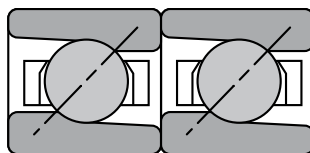

**Tandem  
DT**

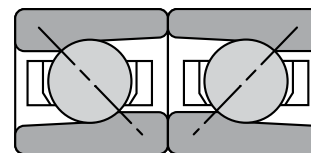

**Face-to-Face  
DF**

Bearing Number	Preload				Axial Stiffness <sup>(1)</sup>				Radial Stiffness <sup>(1)</sup>				Spacer Offsets <sup>(1)</sup>		
	DUX X-light	DUL Light	DUM Med.	DUH Heavy	X-light	Light	Med.	Heavy	X-light	Light	Med.	Heavy	X-light to Light	Light to Med.	Med. to Heavy
	N lbs.	N lbs.	N lbs.	N lbs.	N/μm 10 <sup>6</sup> lbs./in.	N/μm 10 <sup>6</sup> lbs./in.	N/μm 10 <sup>6</sup> lbs./in.	N/μm 10 <sup>6</sup> lbs./in.	N/μm 10 <sup>6</sup> lbs./in.	N/μm 10 <sup>6</sup> lbs./in.	N/μm 10 <sup>6</sup> lbs./in.	N/μm 10 <sup>6</sup> lbs./in.	μm in.	μm in.	μm in.
3MV/MM9315WICR 71915E-T-P4/P4S	155 35	310 70	760 170	1330 300	143.02 0.817	180.80 1.034	251.30 1.437	313.40 1.792	300.14 1.714	385.70 2.205	518.80 2.966	622.80 3.561	3.81 0.00015	8.13 0.00032	8.13 0.00032
3MV/MM9316WICR 71916E-T-P4/P4S	180 40	330 75	800 180	1380 310	156.07 0.891	194.80 1.114	269.30 1.540	332.70 1.902	332.81 1.901	415.70 2.377	556.70 3.183	663.40 3.793	3.53 0.00014	7.87 0.00031	7.62 0.00030
3MV/MM9317WICR 71917E-T-P4/P4S	220 50	470 100	1160 240	2000 420	167.43 0.956	235.80 1.229	329.90 1.705	408.00 2.126	362.86 2.072	504.10 2.642	682.10 3.528	814.20 4.221	4.64 0.00018	9.65 0.00038	9.14 0.00038
3MV/MM9318WICR 71918E-T-P4/P4S	220 50	400 90	930 210	1670 375	166.56 0.951	212.70 1.216	290.50 1.661	363.10 2.076	353.59 2.019	455.30 2.603	605.20 3.460	730.20 4.175	4.20 0.00017	8.38 0.00033	8.89 0.00035
3MV/MM9319WICR 71919E-T-P4/P4S	220 50	470 105	1160 260	2000 450	181.36 1.036	235.80 1.348	329.90 1.886	408.00 2.333	385.62 2.202	504.10 2.882	682.10 3.900	814.20 4.655	4.67 0.00018	9.65 0.00038	9.14 0.00036
3MV/MM9320WICR 71920E-T-P4/P4S	310 70	600 135	1470 330	2560 575	208.89 1.193	264.30 1.511	369.20 2.111	459.80 2.629	447.55 2.556	562.00 3.213	754.70 4.315	901.40 5.154	4.87 0.00019	10.92 0.00043	10.41 0.00041
3MV/MM9322WICR 71922E-T-P4/P4S	330 75	670 150	1600 360	2780 625	223.48 1.276	286.50 1.638	397.90 2.275	494.80 2.829	478.83 2.734	608.70 3.480	812.10 4.643	968.60 5.538	5.21 0.00021	10.92 0.00043	10.41 0.00041
3MV/MM9324WICR 71924E-T-P4/P4S	400 90	800 180	1960 440	3450 775	246.50 1.408	311.70 1.782	421.30 2.409	543.90 3.110	517.55 2.955	663.70 3.795	891.80 5.099	1069.20 6.113	5.68 0.00022	12.19 0.00048	12.19 0.00048
3MV/MM9326WICR 71926E-T-P4/P4S	510 115	1020 230	2450 550	4340 975	274.75 1.569	352.60 2.016	488.30 2.792	611.50 3.496	589.82 3.368	751.20 4.295	1002.20 5.730	1198.90 6.855	6.50 0.00026	13.46 0.00053	13.72 0.00054
3MV/MM9328WICR 71928E-T-P4/P4S	530 120	1070 240	2560 575	4450 1000	290.81 1.661	373.10 2.130	516.80 2.950	642.10 3.660	624.06 3.564	795.40 4.548	1062.20 6.073	1268.50 7.253	6.41 0.00025	13.21 0.00052	13.21 0.00052
3MV/MM9330WICR 71930E-T-P4/P4S	710 160	1450 325	3450 775	6000 1350	312.13 1.782	401.10 2.296	551.10 3.172	688.20 3.939	665.61 3.801	854.60 4.886	1144.00 6.519	1363.00 7.793	8.19 0.00032	16.76 0.00066	16.26 0.00064
3MV/MM9332WICR 71932E-T-P4/P4S	800 180	1580 355	3950 890	6940 1560	328.01 1.873	418.20 2.388	588.90 3.363	734.10 4.192	705.23 4.027	876.50 5.119	1215.90 6.943	1455.70 8.312	8.32 0.00033	18.80 0.00074	17.78 0.00070
3MV/MM9334WICR 71934E-T-P4/P4S	800 180	1600 360	4000 900	6940 1560	329.63 1.882	440.00 2.512	618.20 3.530	760.40 4.342	704.23 4.021	944.30 5.392	1280.70 7.313	1519.00 8.674	9.20 0.00036	18.29 0.00072	16.26 0.00064
3MV/MM9340WICR 71940E-T-P4/P4S	1250 280	3110 700	6230 1400	12460 2800	415.57 2.373	580.10 3.317	751.00 4.294	985.00 5.632	888.10 5.071	1222.00 6.987	1537.00 8.788	1920.40 10.980	14.97 0.00059	18.80 0.00074	28.70 0.00113

**ULTRA-LIGHT ISO 19 SERIES**  
**2MV/MM9300WI (71900C-...-P4/P4S)**  
**SPEED CAPABILITY DATA**

Fafnir Bearing Number	Timken ISO Bearing Number	Grease Capacity <sup>(1)</sup>				Operating Speeds <sup>(4)</sup> (DB Mounting) <sup>(5)</sup>					
		Low Speed <sup>(2)</sup>		High Speed <sup>(3)</sup>		Grease			Oil		
		25%	40%	10%	15%	DUL	DUM	DUH	DUL	DUM	DUH
		grams	grams	grams	grams	RPM	RPM	RPM	RPM	RPM	RPM
2MV/MM9300WICR	71900C-T-P4/P4S	0.09	0.15	0.04	0.06	62000	46500	31000	105400	79100	52700
2MV/MM9301WICR	71901C-T-P4/P4S	0.11	0.17	0.05	0.07	53800	40300	26900	91500	68500	45700
2MV/MM9302WICR	71902C-T-P4/P4S	0.17	0.28	0.08	0.12	44500	33400	22200	75700	56800	37700
2MV/MM9303WICR	71903C-T-P4/P4S	0.19	0.30	0.08	0.12	40100	30100	20000	68200	51200	34000
2MV/MM9304WICR	71904C-T-P4/P4S	0.40	0.60	0.17	0.25	33700	25300	16800	57300	43000	28600
2MV/MM9305WICR	71905C-T-P4/P4S	0.40	0.70	0.20	0.29	27800	20900	13900	47300	35500	23600
2MV/MM9306WICR	71906C-T-P4/P4S	0.50	0.80	0.23	0.34	23800	17800	11900	40500	30300	20200
2MV/MM9307WICR	71907C-T-P4/P4S	0.80	1.20	0.34	0.51	20300	15200	10200	34500	25800	17300
2MV/MM9308WICR	71908C-T-P4/P4S	1.20	1.90	0.54	0.80	17900	13400	9000	30400	22800	15300
2MV/MM9309WICR	71909C-T-P4/P4S	1.30	2.10	0.59	0.88	16000	12000	8000	27200	20400	13600
2MV/MM9310WICR	71910C-T-vP4S	1.40	2.30	0.64	0.95	14600	11000	7300	24800	18700	12400
2MV/MM9311WICR	71911C-T-P4/P4S	1.90	3.00	0.85	1.30	13300	10000	6600	22600	17000	11200
2MV/MM9312WICR	71912C-T-P4/P4S	2.00	3.20	0.90	1.40	12200	9200	6100	20700	15600	10400
2MV/MM9313WICR	71913C-T-P4/P4S	2.10	3.40	0.95	1.40	11400	8500	5700	19400	14500	9700
2MV/MM9314WICR	71914C-T-P4/P4S	3.60	5.70	1.60	2.40	10500	7900	5200	17900	13400	8800
2MV/MM9315WICR	71915C-T-P4/P4S	3.80	6.10	1.70	2.50	9800	7400	4900	16700	12600	8300
2MV/MM9316WICR	71916C-T-P4/P4S	4.00	6.40	1.75	2.70	9300	7000	4600	15800	11900	7800
2MV/MM9317WICR	71917C-T-P4/P4S	5.30	8.60	2.40	3.60	8600	6500	4300	14600	11100	7300
2MV/MM9318WICR	71918C-T-P4/P4S	5.90	9.40	2.60	3.90	8200	6200	4100	13900	10500	7000
2MV/MM9319WICR	71919C-T-P4/P4S	6.10	9.70	2.70	4.10	7800	5900	3900	13300	10000	6600
2MV/MM9320WICR	71920C-T-P4/P4S	7.50	12.00	3.35	5.00	7300	5500	3600	12400	9400	6100
2MV/MM9322WICR	71922C-T-P4/P4S	8.10	13.00	3.65	5.40	6700	5000	3400	11400	8500	5800
2MV/MM9324WICR	71924C-T-P4/P4S	11.10	17.80	4.95	7.40	6200	4600	3100	10500	7800	5300
2MV/MM9326WICR	71926C-T-P4/P4S	14.60	23.30	6.50	9.70	5700	4300	2800	9700	7300	4800
2MV/MM9328WICR	71928C-T-P4/P4S	15.50	24.80	6.90	10.40	5300	4000	2600	9000	6800	4400
2MV/MM9330WICR	71930C-T-P4/P4S	24.80	39.70	11.05	16.60	5000	3700	2500	8500	6300	4300
2MV/MM9332WICR	71932C-T-P4/P4S	26.20	41.90	11.65	17.50	4600	3500	2300	7900	5900	3900
2MV/MM9334WICR	71934C-T-P4/P4S	28.20	45.20	12.55	18.90	4400	3300	2200	7500	5600	3700
2MV/MM9340WICR	71940C-T-P4/P4S	56.80	90.90	25.30	37.90	3700	2800	1800	6300	4700	3100

<sup>(1)</sup>Fill weights based on specific gravity of 0.99.

<sup>(2)</sup>Low speed <500000 dN.

<sup>(3)</sup>High speed > 500000 dN.

<sup>(4)</sup>For ceramic ball complements, use 120 percent of speeds shown.

<sup>(5)</sup>For other mounting arrangement configurations, refer to the engineering section on permissible speed calculation methods.



**ULTRA-LIGHT ISO 19 SERIES**  
**3MV/MM9300WI (71900E-...-P4/P4S)**  
**SPEED CAPABILITY DATA**

Fafnir Bearing Number	Timken ISO Bearing Number	Grease Capacity <sup>(1)</sup>				Operating Speeds <sup>(4)</sup> (DB Mounting) <sup>(5)</sup>					
		Low Speed <sup>(2)</sup>		High Speed <sup>(3)</sup>		Grease			Oil		
		25%	40%	10%	15%	DUL	DUM	DUH	DUL	DUM	DUH
		grams	grams	grams	grams	RPM	RPM	RPM	RPM	RPM	RPM
3MV/MM9300WICR	71900E-T-P4/P4S	0.09	0.15	0.06	0.08	55800	41850	27900	94860	71190	47430
3MV/MM9301WICR	71901E-T-P4/P4S	0.11	0.17	0.07	0.10	48420	36270	24210	82350	61650	41130
3MV/MM9302WICR	71902E-T-P4/P4S	0.17	0.28	0.12	0.15	40050	30060	19980	68130	51120	33930
3MV/MM9303WICR	71903E-T-P4/P4S	0.19	0.30	0.12	0.16	36090	27090	18000	61380	46080	30600
3MV/MM9304WICR	71904E-T-P4/P4S	0.40	0.60	0.25	0.34	30330	22770	15120	51570	38700	25740
3MV/MM9305WICR	71905E-T-P4/P4S	0.40	0.70	0.29	0.39	25020	18810	12510	42570	31950	21240
3MV/MM9306WICR	71906E-T-P4/P4S	0.50	0.80	0.34	0.45	21420	16020	10710	36450	27270	18180
3MV/MM9307WICR	71907E-T-P4/P4S	0.80	1.20	0.51	0.68	18270	13680	9180	31050	23220	15570
3MV/MM9308WICR	71908E-T-P4/P4S	1.20	1.90	0.80	1.07	16110	12060	8100	27360	20520	3770
3MV/MM9309WICR	71909E-T-P4/P4S	1.30	2.10	0.88	1.18	14400	10800	7200	24480	18360	12240
3MV/MM9310WICR	71910E-T-P4/P4S	1.40	2.30	0.95	1.27	13140	9900	6570	22320	16830	11160
3MV/MM9311WICR	71911E-T-P4/P4S	1.90	3.00	1.30	1.70	11970	9000	5940	20340	15300	10080
3MV/MM9312WICR	71912E-T-P4/P4S	2.00	3.20	1.40	1.80	10980	8280	5490	18630	14040	9360
3MV/MM9313WICR	71913E-T-P4/P4S	2.10	3.40	1.40	1.90	10260	7650	5130	17460	13050	8730
3MV/MM9314WICR	71914E-T-P4/P4S	3.60	5.70	2.40	3.20	9450	7110	4680	16110	12060	7920
3MV/MM9315WICR	71915E-T-P4/P4S	3.80	6.10	2.50	3.40	8820	6660	4410	15030	11340	7470
3MV/MM9316WICR	71916E-T-P4/P4S	4.00	6.40	2.70	3.50	8370	6300	4140	14220	10710	7020
3MV/MM9317WICR	71917E-T-P4/P4S	5.30	8.60	3.60	4.80	7740	5850	3870	13140	9990	6570
3MV/MM9318WICR	71918E-T-P4/P4S	5.90	9.40	3.90	5.20	7380	5580	3690	12510	9450	6300
3MV/MM9319WICR	71919E-T-P4/P4S	6.10	9.70	4.10	5.40	7020	5310	3510	11970	9000	5940
3MV/MM9320WICR	71920E-T-P4/P4S	7.50	12.00	5.00	6.70	6570	4950	3240	11160	8460	5490
3MV/MM9322WICR	71922E-T-P4/P4S	8.10	13.00	5.40	7.30	6030	4500	3060	10260	7650	5220
3MV/MM9324WICR	71924E-T-P4/P4S	11.10	17.80	7.40	9.90	5580	4140	2790	9450	7020	4770
3MV/MM9326WICR	71926E-T-P4/P4S	14.60	23.30	9.70	13.00	5130	3870	2520	8730	6570	4320
3MV/MM9328WICR	71928E-T-P4/P4S	15.50	24.80	10.40	13.80	4770	3600	2340	8100	6120	3960
3MV/MM9330WICR	71930E-T-P4/P4S	24.80	39.70	16.60	22.10	4500	3330	2250	7650	5670	3870
3MV/MM9332WICR	71932E-T-P4/P4S	26.20	41.90	17.50	23.30	4140	3150	2070	7110	5310	3510
3MV/MM9334WICR	71934E-T-P4/P4S	28.20	45.20	18.90	25.10	3960	2970	1980	6750	5040	3330
3MV/MM9340WICR	71940E-T-P4/P4S	56.80	90.90	37.90	50.60	3330	2520	1620	5670	4230	2790

<sup>(1)</sup>Fill weights based on specific gravity of 0.99.

<sup>(2)</sup>Low speed <500000 dN.

<sup>(3)</sup>High speed > 500000 dN.

<sup>(4)</sup>For ceramic ball complements, use 120 percent of speeds shown.

<sup>(5)</sup>For other mounting arrangement configurations, refer to the engineering section on speed calculation methods.

### ULTRA-LIGHT ISO 19 SERIES 2(3)MMV9300HX (HX71900C(E)-...-P4S) SUPER PRECISION MMV

Running accuracy and performance meet ABEC 9 (ISO P2) levels. Other features conform to ABEC 7 (ISO P4) requirements.

#### WN CONSTRUCTION

- Incorporates low shoulder on non-thrust side of both inner and outer rings.
- Balls separated by one-piece cage piloted against a ground thrust shoulder land of the outer ring.

#### HIGH-SPEED SEAL OPTION

Available with non-contact seals. Add VV suffix to part number (in place of CR cage designation). Ex: 2MMV9106HXVV SUL.

Bearing Number 15° C/2 <sup>(3)</sup> or 25° E/3 <sup>(4)</sup>	d Bore	D O.D.	C Width <sup>(1)</sup>	Ball Qty. x Dia.	Bearing Wt.	15° (C/2) Load Ratings						25° (E/3) Load Ratings					
						Steel Ball			Ceramic Ball			Steel Ball			Ceramic Ball		
						C <sub>0</sub> Static	C <sub>e</sub> Dynamic	Speed Rating <sup>(N<sub>g</sub>)</sup>	C <sub>0</sub> Static	C <sub>e</sub> Dynamic	Speed Rating <sup>(N<sub>g</sub>)</sup>	C <sub>0</sub> Static	C <sub>e</sub> Dynamic	Speed Rating <sup>(N<sub>g</sub>)</sup>	C <sub>0</sub> Static	C <sub>e</sub> Dynamic	Speed Rating <sup>(N<sub>g</sub>)</sup>
mm in.	mm in.	mm in.	mm in.	kg lbs.	N lbs.	N lbs.	RPM	N lbs.	N lbs.	RPM	N lbs.	N lbs.	RPM	N lbs.	N lbs.	RPM	
9300HX HX71900	10 0.3937	22 0.8661	6 0.2362	13 x 2.4 13 x 3/32	0.010 0.02	534 120	1468 330	91700 91700	489 110	1468 330	110040 110040	534 120	1379 310	82500 82500	489 110	1379 310	99000 99000
9301HX HX71901	12 0.4724	24 0.9449	6 0.2362	14 x 2.4 14 x 3/32	0.010 0.03	610 140	1500 340	80000 80000	540 120	1500 340	96000 96000	580 130	1420 320	72000 72000	520 120	1420 320	86400 86400
9302HX HX71902	15 0.5906	28 1.1024	7 0.2756	16 x 2.8 16 x 7/64	0.020 0.04	979 220	2091 470	66800 66800	890 200	2091 470	80160 80160	890 200	2046 460	60100 60100	801 180	2046 460	72120 72120
9303HX HX71903	17 0.6693	30 1.1811	7 0.2756	17 x 2.8 17 x 7/64	0.020 0.04	1023 230	2224 500	60400 60400	934 210	2224 500	72480 72480	979 220	2091 470	54400 54400	890 200	2091 470	65280 65280
9304HX HX71904	20 0.7874	37 1.4567	9 0.3543	17 x 3.6 17 x 9/64	0.040 0.08	1690 380	3514 790	50200 50200	1512 340	3514 790	60240 60240	1601 360	3336 750	45200 45200	1423 320	3336 750	54240 54240
9305HX HX71905	25 0.9843	42 1.6535	9 0.3543	20 x 3.6 20 x 9/64	0.040 0.10	2020 450	3460 780	41800 41800	1800 400	3460 780	50160 50160	1913 430	3603 810	37600 37600	1735 390	3603 810	45120 45120
9306HX HX71906	30 1.1811	47 1.8504	9 0.3543	23 x 3.6 23 x 9/64	0.050 0.11	2402 540	4048 910	35900 35900	2135 480	4048 910	43080 43080	2224 500	3825 860	32300 32300	1957 440	3825 860	38760 38760
9307HX HX71907	35 1.3780	55 2.1654	10 0.3937	25 x 4.0 25 x 3/32	0.080 0.18	3158 710	5115 1150	30500 30500	2847 640	5115 1150	36600 36600	2980 670	4804 1080	27500 27500	2624 590	4804 1080	33000 33000
9308HX HX71908	40 1.5748	62 2.4409	12 0.4724	19 x 6.4 19 x 1/4	0.110 0.25	6005 1350	10675 2400	28000 28000	5338 1200	10675 2400	33600 33600	5693 1280	10097 2270	25200 25200	5071 1140	10097 2270	30240 30240
9309HX HX71909	45 1.7717	68 2.6772	12 0.4724	21 x 6.4 21 x 1/4	0.130 0.29	6716 1510	11164 2510	25000 25000	6005 1350	11164 2510	30000 30000	6405 1440	10586 2380	22500 22500	5693 1280	10586 2380	27000 27000
9310HX HX71910	50 1.9685	72 2.8346	12 0.4724	23 x 6.4 23 x 1/4	0.140 0.30	7473 1680	11698 2630	22900 22900	6672 1500	11698 2630	27480 27480	7072 1590	11031 2480	20600 20600	6405 1440	11031 2480	24720 24720
9311HX HX71911	55 2.1654	80 3.1496	13 0.5118	23 x 7.1 23 x 3/32	0.190 0.39	9430 2120	14500 3260	20700 20700	8407 1890	14500 3260	24840 24840	8896 2000	13700 3080	18600 18600	7917 1780	13700 3080	22320 22320
9312HX HX71912	60 2.3622	85 3.3465	13 0.5118	25 x 7.1 25 x 3/32	0.200 0.43	10319 2320	15123 3400	19200 19200	9207 2070	15123 3400	23040 23040	9697 2180	14278 3210	17300 17300	8629 1940	14278 3210	20760 20760
9313HX HX71913	65 2.5591	90 3.5433	13 0.5118	27 x 7.1 27 x 3/32	0.220 0.45	11164 2510	15701 3530	17800 17800	9919 2230	15701 3530	21360 21360	10400 2340	14800 3320	16000 16000	9250 2080	14800 3320	19200 19200

<sup>(N<sub>g</sub>)</sup>For a single, grease-lubricated, spring-preloaded bearing. This value to be used in permissible operating speed (Sp) calculation.

<sup>(1)</sup>Width tolerance of preloaded bearing set +0.000/-0.254 mm (+0.0000/-0.0100 in.).

<sup>(2)</sup>Fill weights based upon specific gravity of 0.99.

<sup>(3)</sup>C is ISO designation for 15° contact angle, 2 is Timken designation for 15° contact angle.

<sup>(4)</sup>E is ISO designation for 25° contact angle, 3 is Timken designation for 25° contact angle.

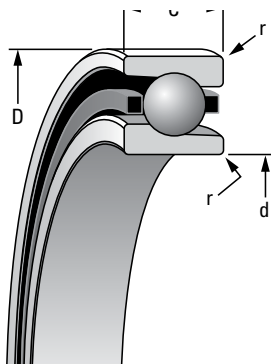

r Rad. (2)	Suggested Shoulder Diameters				Shaft Diameter				FIXED				FLOATING			
	Shaft		Housing						Housing Bore (Stationary)		Mounting Fits		Housing Bore (Stationary)		Mounting Fits	
	Max.	Min.	Max.	Min.	Max.	Min.	Loose	Tight	Max.	Min.	Tight	Loose	Max.	Min.	Loose	Loose
mm in.	mm in.	mm in.	mm in.	mm in.	mm in.	mm in.	mm in.	mm in.	mm in.	mm in.	mm in.	mm in.	mm in.	mm in.	mm in.	mm in.
<b>0.3</b>	<b>13.2</b>	<b>13.0</b>	<b>19.6</b>	<b>19.3</b>	<b>10.000</b>	<b>9.995</b>	<b>0.005</b>	<b>0.004</b>	<b>22.005</b>	<b>22.000</b>	<b>0.000</b>	<b>0.010</b>	<b>22.010</b>	<b>22.005</b>	<b>0.015</b>	<b>0.005</b>
0.012	0.52	0.51	0.77	0.76	0.39370	0.39350	0.00020	0.00015	0.86630	0.86610	0.00000	0.00040	0.86650	0.86630	0.00060	0.00020
<b>0.3</b>	<b>15.2</b>	<b>14.9</b>	<b>21.6</b>	<b>21.3</b>	<b>12.000</b>	<b>11.995</b>	<b>0.005</b>	<b>0.004</b>	<b>24.005</b>	<b>24.000</b>	<b>0.000</b>	<b>0.010</b>	<b>24.010</b>	<b>24.005</b>	<b>0.015</b>	<b>0.005</b>
0.012	0.60	0.59	0.85	0.84	0.47240	0.47220	0.00020	0.00015	0.94510	0.94490	0.00000	0.00040	0.94530	0.94510	0.00060	0.00020
<b>0.3</b>	<b>18.3</b>	<b>18.1</b>	<b>25.5</b>	<b>25.2</b>	<b>15.000</b>	<b>14.995</b>	<b>0.005</b>	<b>0.004</b>	<b>28.005</b>	<b>28.000</b>	<b>0.000</b>	<b>0.010</b>	<b>28.010</b>	<b>28.005</b>	<b>0.015</b>	<b>0.005</b>
0.012	0.72	0.71	1.00	0.99	0.59060	0.59040	0.00020	0.00015	1.02380	1.02360	0.00000	0.00040	1.02400	1.02380	0.00060	0.00020
<b>0.3</b>	<b>20.3</b>	<b>20.0</b>	<b>27.5</b>	<b>27.2</b>	<b>17.000</b>	<b>16.995</b>	<b>0.005</b>	<b>0.004</b>	<b>30.005</b>	<b>30.000</b>	<b>0.000</b>	<b>0.010</b>	<b>30.010</b>	<b>30.005</b>	<b>0.015</b>	<b>0.005</b>
0.012	0.80	0.79	1.08	1.07	0.66930	0.66910	0.00020	0.00015	1.18130	1.18110	0.00000	0.00040	1.18150	1.18130	0.00060	0.00020
<b>0.3</b>	<b>24.1</b>	<b>23.9</b>	<b>33.7</b>	<b>33.4</b>	<b>20.000</b>	<b>19.995</b>	<b>0.005</b>	<b>0.005</b>	<b>37.006</b>	<b>37.000</b>	<b>0.000</b>	<b>0.012</b>	<b>37.010</b>	<b>37.005</b>	<b>0.016</b>	<b>0.005</b>
0.012	0.95	0.94	1.33	1.32	0.78740	0.78720	0.00020	0.00020	1.45700	1.45670	0.00000	0.00050	1.45710	1.45690	0.00070	0.00020
<b>0.3</b>	<b>29.1</b>	<b>28.9</b>	<b>38.7</b>	<b>38.4</b>	<b>25.000</b>	<b>24.995</b>	<b>0.005</b>	<b>0.005</b>	<b>42.006</b>	<b>42.000</b>	<b>0.000</b>	<b>0.012</b>	<b>42.010</b>	<b>42.005</b>	<b>0.016</b>	<b>0.005</b>
0.012	1.15	1.14	1.52	1.51	0.98430	0.98410	0.00020	0.00020	1.65380	1.65350	0.00000	0.00050	1.65390	1.65370	0.00070	0.00020
<b>0.3</b>	<b>34.1</b>	<b>33.9</b>	<b>43.7</b>	<b>43.4</b>	<b>30.000</b>	<b>29.995</b>	<b>0.005</b>	<b>0.005</b>	<b>47.006</b>	<b>47.000</b>	<b>0.000</b>	<b>0.012</b>	<b>47.012</b>	<b>47.007</b>	<b>0.018</b>	<b>0.007</b>
0.012	1.34	1.33	1.72	1.71	1.18110	1.18090	0.00020	0.00020	1.85070	1.85040	0.00000	0.00050	1.85090	1.85070	0.00080	0.00030
<b>0.6</b>	<b>40.0</b>	<b>39.5</b>	<b>51.1</b>	<b>50.6</b>	<b>35.000</b>	<b>34.995</b>	<b>0.005</b>	<b>0.006</b>	<b>55.008</b>	<b>55.000</b>	<b>0.000</b>	<b>0.015</b>	<b>55.012</b>	<b>55.007</b>	<b>0.019</b>	<b>0.007</b>
0.024	1.57	1.55	2.01	1.99	1.37800	1.37780	0.00020	0.00025	2.16570	2.16540	0.00000	0.00060	2.16590	2.16570	0.00080	0.00030
<b>0.6</b>	<b>45.1</b>	<b>44.6</b>	<b>57.9</b>	<b>57.4</b>	<b>40.000</b>	<b>39.995</b>	<b>0.005</b>	<b>0.006</b>	<b>62.008</b>	<b>62.000</b>	<b>0.000</b>	<b>0.015</b>	<b>62.012</b>	<b>62.007</b>	<b>0.019</b>	<b>0.007</b>
0.024	1.78	1.76	2.28	2.26	1.57480	1.57460	0.00020	0.00025	2.44120	2.44090	0.00000	0.00060	2.44140	2.44120	0.00080	0.00030
<b>0.6</b>	<b>50.7</b>	<b>50.1</b>	<b>63.4</b>	<b>62.9</b>	<b>45.000</b>	<b>44.995</b>	<b>0.005</b>	<b>0.006</b>	<b>68.008</b>	<b>68.000</b>	<b>0.000</b>	<b>0.015</b>	<b>68.012</b>	<b>68.007</b>	<b>0.019</b>	<b>0.007</b>
0.024	1.99	1.97	2.50	2.48	1.77170	1.77150	0.00020	0.00025	2.67750	2.67720	0.00000	0.00060	2.67770	2.67750	0.00080	0.00030
<b>0.6</b>	<b>55.1</b>	<b>54.6</b>	<b>67.9</b>	<b>67.4</b>	<b>50.000</b>	<b>49.995</b>	<b>0.005</b>	<b>0.006</b>	<b>72.008</b>	<b>72.000</b>	<b>0.000</b>	<b>0.015</b>	<b>72.011</b>	<b>72.007</b>	<b>0.019</b>	<b>0.007</b>
0.024	2.17	2.15	2.67	2.65	1.96850	1.96830	0.00020	0.00025	2.83490	2.83460	0.00000	0.00060	2.83510	2.83490	0.00080	0.00030
<b>1.0</b>	<b>60.9</b>	<b>60.4</b>	<b>75.2</b>	<b>74.7</b>	<b>55.000</b>	<b>54.995</b>	<b>0.005</b>	<b>0.007</b>	<b>80.008</b>	<b>80.000</b>	<b>0.000</b>	<b>0.015</b>	<b>80.012</b>	<b>80.008</b>	<b>0.020</b>	<b>0.008</b>
0.039	2.40	2.38	2.96	2.94	2.16540	2.16520	0.00020	0.00030	3.14990	3.14960	0.00000	0.00060	3.15010	3.14990	0.00080	0.00030
<b>1.0</b>	<b>65.8</b>	<b>65.3</b>	<b>80.2</b>	<b>79.7</b>	<b>60.000</b>	<b>59.995</b>	<b>0.005</b>	<b>0.007</b>	<b>85.008</b>	<b>85.000</b>	<b>0.000</b>	<b>0.016</b>	<b>85.016</b>	<b>85.009</b>	<b>0.024</b>	<b>0.009</b>
0.039	2.59	2.57	3.16	3.14	2.36220	2.36200	0.00020	0.00030	3.34680	3.34650	0.00000	0.00060	3.34710	3.34680	0.00090	0.00030
<b>1.0</b>	<b>70.8</b>	<b>70.3</b>	<b>85.2</b>	<b>84.7</b>	<b>65.000</b>	<b>64.995</b>	<b>0.005</b>	<b>0.007</b>	<b>90.008</b>	<b>90.000</b>	<b>0.000</b>	<b>0.016</b>	<b>90.015</b>	<b>90.007</b>	<b>0.023</b>	<b>0.007</b>
0.039	2.79	2.77	3.35	3.33	2.55910	2.55890	0.00020	0.00030	3.54360	3.54330	0.00000	0.00060	3.54390	3.54360	0.00090	0.00030

Continued on next page.

**ULTRA-LIGHT ISO 19 SERIES — continued**  
**2(3)MMV9300HX (HX71900C(E)-...-P4S)**  
**SUPER PRECISION MMV**

Running accuracy and performance meet ABEC 9 (ISO P2) levels.  
 Other features conform to ABEC 7 (ISO P4) requirements.

**WN CONSTRUCTION**

- Incorporates low shoulder on non-thrust side of both inner and outer rings.
- Balls separated by one-piece cage piloted against a ground thrust shoulder land of the outer ring.

**HIGH-SPEED SEAL OPTION**

Available with non-contact seals. Add VV suffix to part number (in place of CR cage designation). Ex: 2MMV9106HXVV SUL.

Bearing Number 15° C/2 <sup>(3)</sup> or 25° E/3 <sup>(4)</sup>	d Bore	D O.D.	C Width <sup>(1)</sup>	Ball Qty. x Dia.	Bearing Wt.	15° (C/2) Load Ratings						25° (E/3) Load Ratings					
						Steel Ball			Ceramic Ball			Steel Ball			Ceramic Ball		
						C <sub>0</sub> Static	C <sub>e</sub> Dynamic	Speed Rating <sup>(N<sub>g</sub>)</sup>	C <sub>0</sub> Static	C <sub>e</sub> Dynamic	Speed Rating <sup>(N<sub>g</sub>)</sup>	C <sub>0</sub> Static	C <sub>e</sub> Dynamic	Speed Rating <sup>(N<sub>g</sub>)</sup>	C <sub>0</sub> Static	C <sub>e</sub> Dynamic	Speed Rating <sup>(N<sub>g</sub>)</sup>
mm in.	mm in.	mm in.	mm in.	kg lbs.	N lbs.	N lbs.	RPM	N lbs.	N lbs.	RPM	N lbs.	N lbs.	RPM	N lbs.	N lbs.	RPM	
9314HX	<b>70</b>	<b>100</b>	<b>16</b>	<b>24 x 8.7</b>	<b>0.340</b>	<b>14767</b>	<b>21306</b>	<b>16400</b>	<b>13166</b>	<b>21306</b>	<b>19680</b>	<b>13922</b>	<b>20105</b>	<b>14800</b>	<b>12365</b>	<b>20105</b>	<b>17760</b>
HX71914	2.7559	3.9370	0.6299	24 x 1/2	0.75	3320	4790	16400	2960	4790	19680	3130	4520	14800	2780	4520	17760
9315HX	<b>75</b>	<b>105</b>	<b>16</b>	<b>25 x 8.7</b>	<b>0.360</b>	<b>14300</b>	<b>15100</b>	<b>15400</b>	<b>12700</b>	<b>15100</b>	<b>18480</b>	<b>14500</b>	<b>20416</b>	<b>13900</b>	<b>12899</b>	<b>20416</b>	<b>16680</b>
HX71915	2.9528	4.1339	0.6299	25 x 1/2	0.80	3210	3400	15400	2860	3400	18480	3260	4590	13900	2900	4590	16680
9316HX	<b>80</b>	<b>110</b>	<b>16</b>	<b>27 x 8.7</b>	<b>0.390</b>	<b>16680</b>	<b>22507</b>	<b>14500</b>	<b>14856</b>	<b>22507</b>	<b>17400</b>	<b>15568</b>	<b>21217</b>	<b>13100</b>	<b>13833</b>	<b>21217</b>	<b>15720</b>
HX71916	3.1496	4.3307	0.6299	27 x 1/2	0.80	3750	5060	14500	3340	5060	17400	3500	4770	13100	3110	4770	15720
9317HX	<b>85</b>	<b>120</b>	<b>18</b>	<b>26 x 9.5</b>	<b>0.560</b>	<b>19171</b>	<b>25754</b>	<b>13500</b>	<b>17036</b>	<b>25754</b>	<b>16200</b>	<b>17836</b>	<b>24242</b>	<b>12200</b>	<b>15879</b>	<b>24242</b>	<b>14640</b>
HX71917	3.3465	4.7244	0.7087	26 x 3/8	1.16	4310	5790	13500	3830	5790	16200	4010	5450	12200	3570	5450	14640
9318HX	<b>90</b>	<b>125</b>	<b>18</b>	<b>26 x 10.3</b>	<b>0.570</b>	<b>22462</b>	<b>29935</b>	<b>12900</b>	<b>19972</b>	<b>29935</b>	<b>15480</b>	<b>20995</b>	<b>28200</b>	<b>11600</b>	<b>18682</b>	<b>28200</b>	<b>13920</b>
HX71918	3.5433	4.9213	0.7087	26 x 13/32	1.20	5050	6730	12900	4490	6730	15480	4720	6340	11600	4200	6340	13920
9320HX	<b>100</b>	<b>140</b>	<b>20</b>	<b>29 x 10.3</b>	<b>0.850</b>	<b>24864</b>	<b>31403</b>	<b>11400</b>	<b>22151</b>	<b>31403</b>	<b>13680</b>	<b>23174</b>	<b>29535</b>	<b>9900</b>	<b>20639</b>	<b>29535</b>	<b>11800</b>
HX71920	3.9370	5.5118	0.7874	29 x 13/32	1.80	5590	7060	11400	4980	7060	13680	5210	6640	10000	4640	6640	12000
9322HX	<b>110</b>	<b>150</b>	<b>20</b>	<b>31 x 10.3</b>	<b>0.920</b>	<b>26377</b>	<b>32204</b>	<b>10500</b>	<b>23485</b>	<b>32204</b>	<b>12600</b>	<b>24597</b>	<b>30291</b>	<b>9500</b>	<b>21884</b>	<b>30291</b>	<b>11400</b>
HX71922	4.3307	5.9055	0.7874	31 x 13/32	1.92	5930	7240	10500	5280	7240	12600	5530	6810	9500	4920	6810	11400
9324HX	<b>120</b>	<b>165</b>	<b>22</b>	<b>30 x 11.9</b>	<b>1.240</b>	<b>34161</b>	<b>41277</b>	<b>9600</b>	<b>30424</b>	<b>41277</b>	<b>11520</b>	<b>31803</b>	<b>38831</b>	<b>8600</b>	<b>28334</b>	<b>38831</b>	<b>10320</b>
HX71924	4.7244	6.4961	0.8661	30 x 1/2	2.60	7680	9280	9600	6840	9280	11520	7150	8730	8600	6370	8730	10320
9328HX	<b>140</b>	<b>190</b>	<b>24</b>	<b>32 x 13.5</b>	<b>1.750</b>	<b>46704</b>	<b>53821</b>	<b>8300</b>	<b>41544</b>	<b>53821</b>	<b>9960</b>	<b>43501</b>	<b>50707</b>	<b>7500</b>	<b>38742</b>	<b>50707</b>	<b>9000</b>
HX71928	5.5118	7.4803	0.9449	32 x 1/2	3.85	10500	12100	8300	9340	12100	9960	9780	11400	7500	8710	11400	9000

<sup>(N<sub>g</sub>)</sup>For a single, grease-lubricated, spring-preloaded bearing. This value to be used in permissible operating speed (Sp) calculation.

<sup>(1)</sup>Width tolerance of preloaded bearing set +0.000/-0.254 mm (+0.0000/-0.0100 in.).

<sup>(2)</sup>Fill weights based upon specific gravity of 0.99.

<sup>(3)</sup>C is ISO designation for 15° contact angle, 2 is Timken designation for 15° contact angle.

<sup>(4)</sup>E is ISO designation for 25° contact angle, 3 is Timken designation for 25° contact angle.

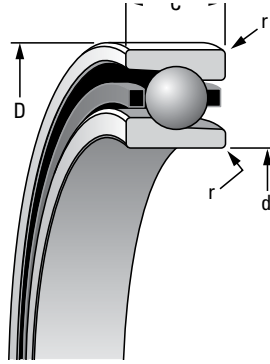

r Rad.(2)	Suggested Shoulder Diameters				Shaft Diameter		Mounting Fits		FIXED				FLOATING			
	Shaft		Housing						Housing Bore (Stationary)		Mounting Fits		Housing Bore (Stationary)		Mounting Fits	
	Max.	Min.	Max.	Min.					Max.	Min.	Tight	Loose	Max.	Min.	Loose	Loose
mm in.	mm in.	mm in.	mm in.	mm in.	mm in.	mm in.	mm in.	mm in.	mm in.	mm in.	mm in.	mm in.	mm in.	mm in.	mm in.	mm in.
<b>1.0</b> 0.039	<b>76.8</b> 3.02	<b>76.3</b> 3.00	<b>94.3</b> 3.71	<b>93.8</b> 3.69	<b>70.000</b> 2.75590	<b>69.995</b> 2.75570	<b>0.005</b> 0.00020	<b>0.007</b> 0.00030	<b>100.008</b> 3.93730	<b>100.000</b> 3.93700	<b>0.000</b> 0.00000	<b>0.016</b> 0.00060	<b>100.018</b> 3.93770	<b>100.010</b> 3.93740	<b>0.025</b> 0.00100	<b>0.010</b> 0.00040
<b>1.0</b> 0.039	<b>81.9</b> 3.22	<b>81.1</b> 3.19	<b>99.4</b> 3.91	<b>98.6</b> 3.88	<b>75.005</b> 2.95300	<b>74.995</b> 2.95260	<b>0.005</b> 0.00020	<b>0.012</b> 0.00050	<b>105.008</b> 4.13420	<b>105.000</b> 4.13390	<b>0.000</b> 0.00000	<b>0.016</b> 0.00060	<b>105.019</b> 4.13460	<b>105.011</b> 4.13430	<b>0.026</b> 0.00100	<b>0.011</b> 0.00040
<b>1.0</b> 0.039	<b>86.9</b> 3.42	<b>86.1</b> 3.39	<b>104.4</b> 4.11	<b>103.6</b> 4.08	<b>80.005</b> 3.14980	<b>79.995</b> 3.14940	<b>0.005</b> 0.00020	<b>0.012</b> 0.00050	<b>110.008</b> 4.33100	<b>110.000</b> 4.33070	<b>0.000</b> 0.00000	<b>0.016</b> 0.00060	<b>110.018</b> 4.33140	<b>110.010</b> 4.33110	<b>0.025</b> 0.00100	<b>0.010</b> 0.00040
<b>1.0</b> 0.039	<b>93.6</b> 3.69	<b>92.8</b> 3.66	<b>112.7</b> 4.44	<b>111.9</b> 4.41	<b>85.005</b> 3.34670	<b>84.995</b> 3.34630	<b>0.005</b> 0.00020	<b>0.012</b> 0.00050	<b>120.008</b> 4.72470	<b>120.000</b> 4.72440	<b>0.000</b> 0.00000	<b>0.016</b> 0.00060	<b>120.018</b> 4.72510	<b>120.010</b> 4.72480	<b>0.025</b> 0.00100	<b>0.010</b> 0.00040
<b>1.0</b> 0.039	<b>97.8</b> 3.85	<b>97.0</b> 3.82	<b>118.5</b> 4.66	<b>117.7</b> 4.63	<b>90.005</b> 3.54350	<b>89.995</b> 3.54310	<b>0.005</b> 0.00020	<b>0.013</b> 0.00050	<b>125.008</b> 4.92160	<b>125.000</b> 4.92130	<b>0.000</b> 0.00000	<b>0.017</b> 0.00070	<b>125.021</b> 4.92210	<b>125.011</b> 4.92170	<b>0.030</b> 0.00120	<b>0.011</b> 0.00040
<b>1.0</b> 0.039	<b>110.3</b> 4.34	<b>109.5</b> 4.31	<b>131.0</b> 5.16	<b>130.2</b> 5.13	<b>100.005</b> 3.93720	<b>99.995</b> 3.93680	<b>0.005</b> 0.00020	<b>0.013</b> 0.00050	<b>140.009</b> 5.51220	<b>140.000</b> 5.51180	<b>0.000</b> 0.00000	<b>0.018</b> 0.00070	<b>140.020</b> 5.51260	<b>140.010</b> 5.51220	<b>0.029</b> 0.00110	<b>0.010</b> 0.00040
<b>1.0</b> 0.039	<b>120.3</b> 4.74	<b>119.5</b> 4.71	<b>141.0</b> 5.55	<b>140.2</b> 5.52	<b>110.005</b> 4.33090	<b>109.995</b> 4.33050	<b>0.005</b> 0.00020	<b>0.013</b> 0.00050	<b>150.009</b> 5.90590	<b>150.000</b> 5.90550	<b>0.000</b> 0.00000	<b>0.018</b> 0.00070	<b>150.023</b> 5.90640	<b>150.012</b> 5.90600	<b>0.032</b> 0.00120	<b>0.012</b> 0.00050
<b>1.0</b> 0.039	<b>131.2</b> 5.16	<b>130.4</b> 5.13	<b>155.0</b> 6.10	<b>154.3</b> 6.07	<b>120.005</b> 4.72460	<b>119.995</b> 4.72420	<b>0.005</b> 0.00020	<b>0.013</b> 0.00050	<b>165.010</b> 6.49650	<b>165.000</b> 6.49610	<b>0.000</b> 0.00000	<b>0.020</b> 0.00080	<b>165.022</b> 6.49700	<b>165.012</b> 6.49660	<b>0.032</b> 0.00130	<b>0.012</b> 0.00050
<b>1.5</b> 0.059	<b>152.1</b> 5.99	<b>151.4</b> 5.96	<b>179.2</b> 7.05	<b>178.4</b> 7.02	<b>140.005</b> 5.51200	<b>139.995</b> 5.51160	<b>0.005</b> 0.00020	<b>0.015</b> 0.00060	<b>190.010</b> 7.48070	<b>190.000</b> 7.48030	<b>0.000</b> 0.00000	<b>0.021</b> 0.00080	<b>190.022</b> 7.48120	<b>190.012</b> 7.48080	<b>0.033</b> 0.00140	<b>0.012</b> 0.00050

**ULTRA-LIGHT ISO 19 SERIES**  
**2MMV9300HX (HX71900C-...-P4S)**  
**DUPLEX PERFORMANCE DATA**

Bearing Number	Preload			Axial Stiffness <sup>(1)</sup>			Radial Stiffness <sup>(1)</sup>			Spacer Offsets <sup>(1)</sup>	
	DuL Light	DuM Medium	DuH Heavy	Light	Medium	Heavy	Light	Medium	Heavy	Light to Med.	Med. to Heavy
	<b>N</b> lbs.	<b>N</b> lbs.	<b>N</b> lbs.	<b>N/μm</b> 10 <sup>6</sup> lbs./in.	<b>N/μm</b> 10 <sup>6</sup> lbs./in.	<b>N/μm</b> 10 <sup>6</sup> lbs./in.	<b>N/μm</b> 10 <sup>6</sup> lbs./in.	<b>N/μm</b> 10 <sup>6</sup> lbs./in.	<b>N/μm</b> 10 <sup>6</sup> lbs./in.	<b>μm</b> in.	<b>μm</b> in.
2MMV9300HXCR	<b>9</b>	<b>25</b>	<b>55</b>	<b>10.20</b>	<b>15.60</b>	<b>21.00</b>	<b>61.00</b>	<b>88.50</b>	<b>110.80</b>	<b>5.60</b>	<b>5.60</b>
HX71900C-T-P4S	2	6	12	0.058	0.089	0.120	0.349	0.506	0.634	0.00022	0.00022
2MMV9301HXCR	<b>9</b>	<b>25</b>	<b>55</b>	<b>10.70</b>	<b>16.70</b>	<b>22.80</b>	<b>61.30</b>	<b>88.20</b>	<b>110.20</b>	<b>5.10</b>	<b>5.60</b>
HX71901C-T-P4S	2	6	12	0.061	0.096	0.130	0.351	0.504	0.630	0.00020	0.00022
2MMV9302HXCR	<b>20</b>	<b>45</b>	<b>85</b>	<b>17.00</b>	<b>22.70</b>	<b>31.00</b>	<b>96.40</b>	<b>120.90</b>	<b>150.90</b>	<b>4.60</b>	<b>6.60</b>
HX71902C-T-P4S	5	10	20	0.097	0.130	0.177	0.551	0.691	0.863	0.00018	0.00026
2MMV9303HXCR	<b>20</b>	<b>45</b>	<b>85</b>	<b>16.90</b>	<b>22.30</b>	<b>30.00</b>	<b>100.90</b>	<b>127.10</b>	<b>159.10</b>	<b>4.60</b>	<b>6.60</b>
HX71903C-T-P4S	5	10	20	0.097	0.128	0.172	0.577	0.727	0.910	0.00018	0.00026
2MMV9304HXCR	<b>20</b>	<b>65</b>	<b>135</b>	<b>18.20</b>	<b>28.50</b>	<b>38.70</b>	<b>109.60</b>	<b>157.90</b>	<b>197.30</b>	<b>7.60</b>	<b>8.10</b>
HX71904C-T-P4S	5	15	30	0.104	0.163	0.221	0.627	0.903	1.128	0.00030	0.00032
2MMV9305HXCR	<b>20</b>	<b>65</b>	<b>135</b>	<b>20.20</b>	<b>31.30</b>	<b>42.30</b>	<b>122.00</b>	<b>176.30</b>	<b>220.50</b>	<b>7.10</b>	<b>7.10</b>
HX71905C-T-P4S	5	15	30	0.115	0.179	0.242	0.698	1.008	1.261	0.00028	0.00028
2MMV9306HXCR	<b>20</b>	<b>65</b>	<b>135</b>	<b>22.00</b>	<b>33.90</b>	<b>45.70</b>	<b>133.70</b>	<b>193.60</b>	<b>242.60</b>	<b>6.10</b>	<b>6.60</b>
HX71906C-T-P4S	5	15	30	0.126	0.194	0.261	0.764	1.107	1.387	0.00024	0.00026
2MMV9307HXCR	<b>45</b>	<b>110</b>	<b>225</b>	<b>30.80</b>	<b>44.60</b>	<b>60.50</b>	<b>185.70</b>	<b>251.70</b>	<b>314.60</b>	<b>7.10</b>	<b>8.60</b>
HX71907C-T-P4S	10	25	50	0.176	0.255	0.346	1.062	1.439	1.799	0.00028	0.00034
2MMV9308HXCR	<b>45</b>	<b>135</b>	<b>265</b>	<b>29.50</b>	<b>45.10</b>	<b>60.10</b>	<b>177.90</b>	<b>259.60</b>	<b>325.70</b>	<b>9.70</b>	<b>10.20</b>
HX71908C-T-P4S	10	30	60	0.169	0.258	0.344	1.017	1.484	1.862	0.00038	0.00040
2MMV9309HXCR	<b>45</b>	<b>155</b>	<b>310</b>	<b>31.50</b>	<b>50.90</b>	<b>68.00</b>	<b>189.40</b>	<b>292.10</b>	<b>366.40</b>	<b>10.70</b>	<b>10.70</b>
HX71909C-T-P4S	10	35	70	0.180	0.291	0.389	1.083	1.670	2.095	0.00042	0.00042
2MMV9310HXCR	<b>65</b>	<b>175</b>	<b>355</b>	<b>38.70</b>	<b>56.70</b>	<b>75.90</b>	<b>232.60</b>	<b>324.60</b>	<b>407.00</b>	<b>9.10</b>	<b>10.70</b>
HX71910C-T-P4S	15	40	80	0.221	0.324	0.434	1.330	1.856	2.327	0.00036	0.00042
2MMV9311HXCR	<b>65</b>	<b>200</b>	<b>400</b>	<b>39.50</b>	<b>60.30</b>	<b>80.50</b>	<b>241.20</b>	<b>352.20</b>	<b>442.00</b>	<b>10.70</b>	<b>11.20</b>
HX71911C-T-P4S	15	45	90	0.226	0.345	0.460	1.379	2.014	2.527	0.00042	0.00044

<sup>(1)</sup>For DB or DF arrangements only. For other mounting arrangements, contact your Timken representative.

**MOUNTING ARRANGEMENTS**

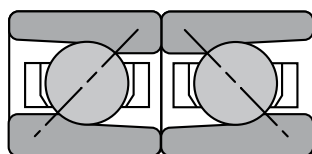

**Back-to-Back  
DB**

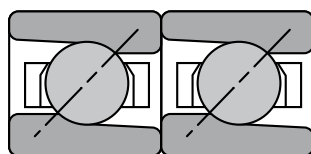

**Tandem  
DT**

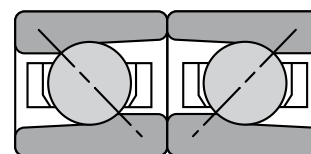

**Face-to-Face  
DF**

Bearing Number	Preload			Axial Stiffness <sup>(1)</sup>			Radial Stiffness <sup>(1)</sup>			Spacer Offsets <sup>(1)</sup>	
	DuL Light	DuM Medium	DuH Heavy	Light	Medium	Heavy	Light	Medium	Heavy	Light to Med.	Med. to Heavy
	<b>N</b> lbs.	<b>N</b> lbs.	<b>N</b> lbs.	<b>N/μm</b> 10 <sup>6</sup> lbs./in.	<b>N/μm</b> 10 <sup>6</sup> lbs./in.	<b>N/μm</b> 10 <sup>6</sup> lbs./in.	<b>N/μm</b> 10 <sup>6</sup> lbs./in.	<b>N/μm</b> 10 <sup>6</sup> lbs./in.	<b>N/μm</b> 10 <sup>6</sup> lbs./in.	<b>μm</b> in.	<b>μm</b> in.
2MMV9312HXCR	<b>65</b>	<b>225</b>	<b>445</b>	<b>41.70</b>	<b>66.20</b>	<b>88.30</b>	<b>254.10</b>	<b>385.70</b>	<b>483.90</b>	<b>11.70</b>	<b>11.70</b>
HX71912C-T-P4S	15	50	100	0.238	0.378	0.505	1.453	2.205	2.767	0.00046	0.00046
2MMV9313HXCR	<b>65</b>	<b>225</b>	<b>445</b>	<b>43.70</b>	<b>69.30</b>	<b>92.30</b>	<b>266.70</b>	<b>406.10</b>	<b>509.80</b>	<b>11.20</b>	<b>11.20</b>
HX71913C-T-P4S	15	50	100	0.250	0.396	0.528	1.525	2.322	2.915	0.00044	0.00044
2MMV9314HXCR	<b>110</b>	<b>335</b>	<b>665</b>	<b>51.00</b>	<b>78.10</b>	<b>104.50</b>	<b>316.60</b>	<b>461.20</b>	<b>578.40</b>	<b>13.70</b>	<b>14.70</b>
HX71914C-T-P4S	25	75	150	0.292	0.447	0.598	1.810	2.637	3.307	0.00054	0.00058
2MMV9315HXCR	<b>110</b>	<b>335</b>	<b>665</b>	<b>52.30</b>	<b>80.00</b>	<b>107.00</b>	<b>325.00</b>	<b>474.00</b>	<b>594.70</b>	<b>13.20</b>	<b>14.20</b>
HX71915C-T-P4S	25	75	150	0.299	0.458	0.612	1.858	2.710	3.400	0.00052	0.00056
2MMV9316HXCR	<b>110</b>	<b>335</b>	<b>665</b>	<b>54.90</b>	<b>83.80</b>	<b>111.80</b>	<b>341.20</b>	<b>499.00</b>	<b>626.50</b>	<b>12.70</b>	<b>13.70</b>
HX71916C-T-P4S	25	75	150	0.314	0.479	0.639	1.951	2.853	3.582	0.00050	0.00054
2MMV9317HXCR	<b>135</b>	<b>400</b>	<b>800</b>	<b>62.20</b>	<b>94.50</b>	<b>125.50</b>	<b>390.60</b>	<b>575.90</b>	<b>724.30</b>	<b>13.70</b>	<b>14.70</b>
HX71917C-T-P4S	30	90	180	0.334	0.510	0.682	2.088	3.048	3.826	0.00056	0.00060
2MMV9318HXCR	<b>135</b>	<b>400</b>	<b>800</b>	<b>59.40</b>	<b>90.40</b>	<b>120.20</b>	<b>373.10</b>	<b>548.10</b>	<b>688.90</b>	<b>14.20</b>	<b>15.20</b>
HX71918C-T-P4S	30	90	180	0.340	0.517	0.687	2.133	3.134	3.939	0.00056	0.00060
2MMV9320HXCR	<b>155</b>	<b>490</b>	<b>975</b>	<b>67.40</b>	<b>104.60</b>	<b>139.50</b>	<b>423.40</b>	<b>630.50</b>	<b>791.80</b>	<b>15.20</b>	<b>15.70</b>
HX71920C-T-P4S	35	110	220	0.385	0.598	0.798	2.421	3.605	4.527	0.00060	0.00062
2MMV9322HXCR	175	535	1065	73.80	112.70	150.40	464.00	678.60	851.90	15.20	16.30
HX71922C-T-P4S	40	120	240	0.422	0.644	0.860	2.653	3.880	4.871	0.00060	0.00064
2MMV9324HXCR	<b>225</b>	<b>665</b>	<b>1335</b>	<b>80.90</b>	<b>123.40</b>	<b>164.70</b>	<b>513.70</b>	<b>752.10</b>	<b>944.30</b>	<b>17.30</b>	<b>18.30</b>
HX71924C-T-P4S	50	150	300	0.462	0.706	0.942	2.937	4.300	5.399	0.00068	0.00072
2MMV9328HXCR	<b>265</b>	<b>800</b>	<b>1600</b>	<b>94.60</b>	<b>143.60</b>	<b>190.60</b>	<b>587.50</b>	<b>865.40</b>	<b>1088.20</b>	<b>17.80</b>	<b>19.30</b>
HX71928C-T-P4S	60	180	360	0.541	0.821	1.090	3.359	4.948	6.222	0.00070	0.00076

**ULTRA-LIGHT ISO 19 SERIES**  
**3MMV9300HX (HX71900E-...-P4S)**  
**DUPLEX PERFORMANCE DATA**

Bearing Number	Preload			Axial Stiffness <sup>(1)</sup>			Radial Stiffness <sup>(1)</sup>			Spacer Offsets <sup>(1)</sup>	
	DUL Light	DUM Medium	DUH Heavy	Light	Medium	Heavy	Light	Medium	Heavy	Light to Med.	Med. to Heavy
	N lbs.	N lbs.	N lbs.	N/μm 10 <sup>6</sup> lbs./in.	N/μm 10 <sup>6</sup> lbs./in.	N/μm 10 <sup>6</sup> lbs./in.	N/μm 10 <sup>6</sup> lbs./in.	N/μm 10 <sup>6</sup> lbs./in.	N/μm 10 <sup>6</sup> lbs./in.	μm in.	μm in.
3MMV9300HXCR	<b>22</b>	<b>45</b>	<b>90</b>	<b>28.53</b>	<b>36.82</b>	<b>48.06</b>	<b>60.22</b>	<b>75.61</b>	<b>94.48</b>	<b>2.79</b>	<b>4.06</b>
HX71900E-T-P4S	5	10	20	0.163	0.211	0.275	0.344	0.432	0.540	0.00011	0.00016
3MMV9301HXCR	<b>22</b>	<b>45</b>	<b>90</b>	<b>29.93</b>	<b>38.58</b>	<b>50.28</b>	<b>63.30</b>	<b>79.51</b>	<b>99.41</b>	<b>2.54</b>	<b>4.06</b>
HX71901E-T-P4S	5	10	20	0.171	0.221	0.288	0.362	0.455	0.568	0.00010	0.00016
3MMV9302HXCR	<b>22</b>	<b>65</b>	<b>135</b>	<b>34.07</b>	<b>50.72</b>	<b>66.06</b>	<b>72.78</b>	<b>104.78</b>	<b>131.04</b>	<b>4.06</b>	<b>4.57</b>
HX71902E-T-P4S	5	15	30	0.195	0.290	0.378	0.416	0.599	0.749	0.00016	0.00018
3MMV9303HXCR	<b>22</b>	<b>65</b>	<b>135</b>	<b>35.45</b>	<b>52.71</b>	<b>68.60</b>	<b>75.75</b>	<b>109.14</b>	<b>136.54</b>	<b>4.06</b>	<b>4.32</b>
HX71903E-T-P4S	5	15	30	0.203	0.301	0.392	0.433	0.624	0.781	0.00016	0.00017
3MMV9304HXCR	<b>45</b>	<b>110</b>	<b>225</b>	<b>48.76</b>	<b>67.98</b>	<b>88.46</b>	<b>103.86</b>	<b>140.69</b>	<b>175.95</b>	<b>4.57</b>	<b>5.59</b>
HX71904E-T-P4S	10	25	50	0.279	0.389	0.506	0.594	0.804	1.006	0.00018	0.00022
3MMV9305HXCR	<b>45</b>	<b>110</b>	<b>225</b>	<b>54.17</b>	<b>75.33</b>	<b>97.75</b>	<b>115.68</b>	<b>156.99</b>	<b>196.59</b>	<b>4.06</b>	<b>5.08</b>
HX71905E-T-P4S	10	25	50	0.310	0.431	0.559	0.661	0.898	1.124	0.00016	0.00020
3MMV9306HXCR	<b>45</b>	<b>110</b>	<b>225</b>	<b>59.33</b>	<b>82.33</b>	<b>106.58</b>	<b>126.87</b>	<b>172.47</b>	<b>216.18</b>	<b>3.56</b>	<b>4.57</b>
HX71906E-T-P4S	10	25	50	0.339	0.471	0.609	0.725	0.986	1.236	0.00014	0.00018
3MMV9307HXCR	<b>65</b>	<b>175</b>	<b>355</b>	<b>74.51</b>	<b>106.06</b>	<b>137.72</b>	<b>159.18</b>	<b>220.72</b>	<b>276.34</b>	<b>5.08</b>	<b>5.59</b>
HX71907E-T-P4S	15	40	80	0.426	0.606	0.787	0.910	1.262	1.580	0.00020	0.00022
3MMV9308HXCR	<b>65</b>	<b>225</b>	<b>445</b>	<b>70.62</b>	<b>108.04</b>	<b>139.41</b>	<b>154.45</b>	<b>233.67</b>	<b>293.31</b>	<b>7.11</b>	<b>7.11</b>
HX71908E-T-P4S	15	50	100	0.404	0.618	0.797	0.883	1.336	1.677	0.00028	0.00028
3MMV9309HXCR	<b>90</b>	<b>245</b>	<b>490</b>	<b>83.32</b>	<b>119.21</b>	<b>153.84</b>	<b>182.60</b>	<b>257.80</b>	<b>323.74</b>	<b>6.10</b>	<b>7.11</b>
HX71909E-T-P4S	20	55	110	0.476	0.682	0.880	1.044	1.474	1.851	0.00024	0.00028
3MMV9310HXCR	<b>90</b>	<b>265</b>	<b>535</b>	<b>88.43</b>	<b>130.41</b>	<b>168.25</b>	<b>193.61</b>	<b>282.11</b>	<b>354.17</b>	<b>6.60</b>	<b>7.11</b>
HX71910E-T-P4S	20	60	120	0.506	0.746	0.962	1.107	1.613	2.025	0.00026	0.00028
3MMV9311HXCR	<b>110</b>	<b>335</b>	<b>665</b>	<b>99.24</b>	<b>146.29</b>	<b>188.72</b>	<b>216.70</b>	<b>315.69</b>	<b>396.50</b>	<b>7.11</b>	<b>8.13</b>

<sup>(1)</sup>For DB or DF arrangements only. For other mounting arrangements, contact your Timken representative.



**MOUNTING ARRANGEMENTS**

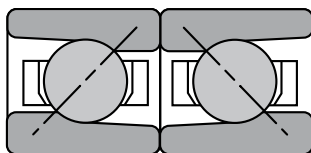

**Back-to-Back  
DB**

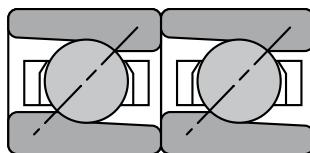

**Tandem  
DT**

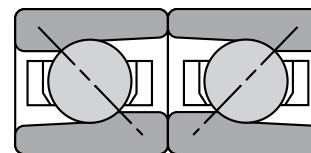

**Face-to-Face  
DF**

Bearing Number	Preload			Axial Stiffness <sup>(1)</sup>			Radial Stiffness <sup>(1)</sup>			Spacer Offsets <sup>(1)</sup>	
	DUL Light	DUM Medium	DUH Heavy	Light	Medium	Heavy	Light	Medium	Heavy	Light to Med.	Med. to Heavy
	<b>N</b> lbs.	<b>N</b> lbs.	<b>N</b> lbs.	<b>N/μm</b> 10 <sup>6</sup> lbs./in.	<b>N/μm</b> 10 <sup>6</sup> lbs./in.	<b>N/μm</b> 10 <sup>6</sup> lbs./in.	<b>N/μm</b> 10 <sup>6</sup> lbs./in.	<b>N/μm</b> 10 <sup>6</sup> lbs./in.	<b>N/μm</b> 10 <sup>6</sup> lbs./in.	<b>μm</b> in.	<b>μm</b> in.
HX71911E-T-P4S	25	75	150	0.567	0.836	1.079	1.239	1.805	2.267	0.00028	0.00032
3MMV9312HXCR	<b>110</b>	<b>335</b>	<b>665</b>	<b>104.80</b>	<b>154.33</b>	<b>198.86</b>	<b>228.59</b>	<b>333.88</b>	<b>419.41</b>	<b>6.60</b>	<b>7.62</b>
HX71912E-T-P4S	25	75	150	0.599	0.882	1.137	1.307	1.909	2.398	0.00026	0.00030
3MMV9313HXCR	<b>110</b>	<b>335</b>	<b>665</b>	<b>110.22</b>	<b>162.15</b>	<b>208.66</b>	<b>239.96</b>	<b>351.37</b>	<b>441.80</b>	<b>6.60</b>	<b>7.11</b>
HX71913E-T-P4S	25	75	150	0.630	0.927	1.193	1.372	2.009	2.526	0.00026	0.00028
3MMV9314HXCR	<b>155</b>	<b>490</b>	<b>980</b>	<b>122.31</b>	<b>183.12</b>	<b>235.94</b>	<b>265.50</b>	<b>394.05</b>	<b>495.14</b>	<b>8.64</b>	<b>9.14</b>
HX71914E-T-P4S	35	110	220	0.699	1.047	1.349	1.518	2.253	2.831	0.00034	0.00036
3MMV9315HXCR	<b>155</b>	<b>490</b>	<b>980</b>	<b>125.63</b>	<b>187.84</b>	<b>242.06</b>	<b>272.49</b>	<b>404.89</b>	<b>508.96</b>	<b>8.64</b>	<b>9.14</b>
HX71915E-T-P4S	35	110	220	0.718	1.074	1.384	1.558	2.315	2.910	0.00034	0.00036
3MMV9316HXCR	<b>155</b>	<b>490</b>	<b>980</b>	<b>132.14</b>	<b>197.46</b>	<b>254.13</b>	<b>285.96</b>	<b>426.23</b>	<b>536.07</b>	<b>8.13</b>	<b>8.64</b>
HX71916E-T-P4S	35	110	220	0.756	1.129	1.453	1.635	2.437	3.065	0.00032	0.00034
3MMV9317HXCR	<b>200</b>	<b>625</b>	<b>1245</b>	<b>155.70</b>	<b>231.57</b>	<b>297.33</b>	<b>334.58</b>	<b>499.86</b>	<b>629.12</b>	<b>8.64</b>	<b>9.14</b>
HX71917E-T-P4S	45	140	280	0.826	1.232	1.588	1.792	2.651	3.331	0.00036	0.00040
3MMV9318HXCR	<b>200</b>	<b>625</b>	<b>1245</b>	<b>148.32</b>	<b>220.72</b>	<b>283.69</b>	<b>319.72</b>	<b>475.73</b>	<b>598.51</b>	<b>9.14</b>	<b>9.65</b>
HX71918E-T-P4S	45	140	280	0.848	1.262	1.622	1.828	2.720	3.422	0.00036	0.00038
3MMV9320HXCR	<b>245</b>	<b>735</b>	<b>1465</b>	<b>170.75</b>	<b>251.16</b>	<b>323.04</b>	<b>369.04</b>	<b>540.62</b>	<b>679.84</b>	<b>9.14</b>	<b>10.16</b>
HX71920E-T-P4S	55	165	330	0.976	1.436	1.847	2.110	3.091	3.887	0.00036	0.00040
3MMV9322HXCR	<b>265</b>	<b>800</b>	<b>1600</b>	<b>183.82</b>	<b>270.40</b>	<b>348.05</b>	<b>397.55</b>	<b>581.89</b>	<b>731.61</b>	<b>9.14</b>	<b>10.16</b>
HX71922E-T-P4S	60	180	360	1.051	1.546	1.990	2.273	3.327	4.183	0.00036	0.00040
3MMV9324HXCR	<b>310</b>	<b>935</b>	<b>1870</b>	<b>198.51</b>	<b>291.73</b>	<b>374.99</b>	<b>427.46</b>	<b>628.07</b>	<b>790.37</b>	<b>10.16</b>	<b>11.18</b>
HX71924E-T-P4S	70	210	420	1.135	1.668	2.144	2.444	3.591	4.519	0.00040	0.00044
3MMV9328HXCR	<b>400</b>	<b>1200</b>	<b>2400</b>	<b>235.07</b>	<b>344.90</b>	<b>443.02</b>	<b>504.06</b>	<b>743.15</b>	<b>935.54</b>	<b>10.67</b>	<b>12.19</b>
HX71928E-T-P4S	90	270	540	1.344	1.972	2.533	2.882	4.249	5.349	0.00042	0.00048

**ULTRA-LIGHT ISO 19 SERIES**  
**2MMV9300HX (HX71900C-...-P4S)**  
**SPEED CAPABILITY DATA**

Fafnir Bearing Number	Timken ISO Bearing Number	Grease Capacity <sup>(1)</sup>				Operating Speeds <sup>(4)</sup> (DB Mounting) <sup>(5)</sup>					
		Low Speed <sup>(2)</sup>		High Speed <sup>(3)</sup>		Grease			Oil		
		25%	40%	10%	15%	DUL	DUM	DUH	DUL	DUM	DUH
		grams	grams	grams	grams	RPM	RPM	RPM	RPM	RPM	RPM
2MMV9300HXCR	HX71900C-T-P4S	0.11	0.18	0.05	0.06	73360	55020	36680	123795	93534	62310
2MMV9301HXCR	HX71901C-T-P4S	0.13	0.20	0.06	0.07	64000	48000	32000	108000	81600	54360
2MMV9302HXCR	HX71902C-T-P4S	0.20	0.33	0.09	0.12	53440	40080	26720	90180	68136	45391
2MMV9303HXCR	HX71903C-T-P4S	0.23	0.36	0.09	0.12	48320	36240	24160	81540	61608	41042
2MMV9304HXCR	HX71904C-T-P4S	0.48	0.71	0.20	0.25	40160	30120	20080	67770	51204	34111
2MMV9305HXCR	HX71905C-T-P4S	0.48	0.83	0.22	0.29	33440	25080	16720	56430	42636	28403
2MMV9306HXCR	HX71906C-T-P4S	0.60	0.95	0.26	0.34	28720	21540	14360	48465	36618	24394
2MMV9307HXCR	HX71907C-T-P4S	0.95	1.43	0.39	0.51	24400	18300	12200	41175	31110	20725
2MMV9308HXCR	HX71908C-T-P4S	1.43	2.26	0.61	0.80	22400	16800	11200	37800	28560	19026
2MMV9309HXCR	HX71909C-T-P4S	1.55	2.50	0.67	0.88	20000	15000	10000	33750	25500	16988
2MMV9310HXCR	HX71910C-T-P4S	1.67	2.74	0.72	0.95	18320	13740	9160	30915	23358	15561
2MMV9311HXCR	HX71911C-T-P4S	2.26	3.57	0.97	1.30	16560	12420	8280	27945	21114	14066
2MMV9312HXCR	HX71912C-T-P4S	2.38	3.81	1.03	1.40	15360	11520	7680	25920	19584	13046
2MMV9313HXCR	HX71913C-T-P4S	2.50	4.05	1.08	1.40	14240	10680	7120	24030	18156	12095
2MMV9314HXCR	HX71914C-T-P4S	4.29	6.79	1.82	2.40	13120	9840	6560	22140	16728	11144
2MMV9315HXCR	HX71915C-T-P4S	4.52	7.26	1.93	2.50	12320	9240	6160	20790	15708	10464
2MMV9316HXCR	HX71916C-T-P4S	4.76	7.62	1.99	2.70	11600	8700	5800	19575	14790	9853
2MMV9317HXCR	HX71917C-T-P4S	6.31	10.24	2.73	3.60	10800	8100	5400	18225	13770	9173
2MMV9318HXCR	HX71918C-T-P4S	7.02	11.19	2.96	3.90	10320	7740	5160	17415	13158	8766
2MMV9320HXCR	HX71920C-T-P4S	8.93	14.29	3.81	5.00	9120	6840	4560	15390	11628	7746
2MMV9322HXCR	HX71922C-T-P4S	9.64	15.48	4.15	5.40	8400	6300	4200	14175	10710	7135
2MMV9324HXCR	HX71924C-T-P4S	13.21	21.19	5.63	7.40	7680	5760	3840	12960	9792	6523
2MMV9328HXCR	HX71928C-T-P4S	18.45	29.52	7.84	10.40	6616	4962	3300	11165	8435	5619

<sup>(1)</sup>Fill weights based on specific gravity of 0.99.

<sup>(2)</sup>Low speed <500000 dN.

<sup>(3)</sup>High speed > 500000 dN.

<sup>(4)</sup>For ceramic ball complements, use 120 percent of speeds shown.

<sup>(5)</sup>For other mounting arrangement configurations, refer to the engineering section on permissible speed calculation methods.

**ULTRA-LIGHT ISO 19 SERIES**  
**3MMV9300HX (HX71900E-...-P4S)**  
**SPEED CAPABILITY DATA**

Fafnir Bearing Number	Timken ISO Bearing Number	Grease Capacity <sup>(1)</sup>				Operating Speeds <sup>(4)</sup> (DB Mounting) <sup>(5)</sup>					
		Low Speed <sup>(2)</sup>		High Speed <sup>(3)</sup>		Grease			Oil		
		25%	40%	10%	15%	DUL	DUM	DUH	DUL	DUM	DUH
		grams	grams	grams	grams	RPM	RPM	RPM	RPM	RPM	RPM
3MMV9300HXCR	HX71900E-T-P4S	0.11	0.18	0.04	0.06	66080	49560	33040	111510	84250	56125
3MMV9301HXCR	HX71901E-T-P4S	0.13	0.20	0.05	0.07	57600	43200	28800	97200	73440	48900
3MMV9302HXCR	HX71902E-T-P4S	0.20	0.33	0.08	0.12	48080	36060	24040	81135	61300	40850
3MMV9303HXCR	HX71903E-T-P4S	0.23	0.36	0.08	0.12	43440	32580	21720	73305	55390	36900
3MMV9304HXCR	HX71904E-T-P4S	0.48	0.71	0.17	0.25	36160	27120	18080	61020	46100	30700
3MMV9305HXCR	HX71905E-T-P4S	0.48	0.83	0.20	0.29	30080	22560	15040	50760	38350	25550
3MMV9306HXCR	HX71906E-T-P4S	0.60	0.95	0.23	0.34	25840	19380	12920	43605	32950	21950
3MMV9307HXCR	HX71907E-T-P4S	0.95	1.43	0.35	0.51	22000	16500	11000	37125	28050	18690
3MMV9308HXCR	HX71908E-T-P4S	1.43	2.26	0.54	0.80	20160	15120	10080	34020	25700	17125
3MMV9309HXCR	HX71909E-T-P4S	1.55	2.50	0.60	0.88	18000	13500	9000	30375	22950	15290
3MMV9310HXCR	HX71910E-T-P4S	1.67	2.74	0.64	0.95	16480	12360	8240	27810	21000	14000
3MMV9311HXCR	HX71911E-T-P4S	2.26	3.57	0.86	1.30	14960	11220	7480	25245	19075	12700
3MMV9312HXCR	HX71912E-T-P4S	2.38	3.81	0.91	1.40	13760	10320	6880	23220	17500	11690
3MMV9313HXCR	HX71913E-T-P4S	2.50	4.05	0.96	1.40	12800	9600	6400	21600	16320	10875
3MMV9314HXCR	HX71914E-T-P4S	4.29	6.79	1.62	2.40	11840	8880	5920	19980	15100	10060
3MMV9315HXCR	HX71915E-T-P4S	4.52	7.26	1.72	2.50	11120	8340	5560	18765	14175	9450
3MMV9316HXCR	HX71916E-T-P4S	4.76	7.62	1.77	2.70	10480	7860	5240	17685	13360	8900
3MMV9317HXCR	HX71917E-T-P4S	6.31	10.24	2.43	3.60	9680	7260	4840	16335	12350	8225
3MMV9318HXCR	HX71918E-T-P4S	7.02	11.19	2.63	3.90	9280	6960	4640	15660	11825	7880
3MMV9320HXCR	HX71920E-T-P4S	8.93	14.29	3.39	5.00	8240	6180	4120	13905	10500	7000
3MMV9322HXCR	HX71922E-T-P4S	9.64	15.48	3.69	5.40	7544	5658	3772	12731	9620	6400
3MMV9324HXCR	HX71924E-T-P4S	13.21	21.19	5.00	7.40	6912	5184	3456	11664	8810	5875
3MMV9328HXCR	HX71928E-T-P4S	18.45	29.52	6.97	10.40	5960	4470	2980	10058	7600	5050

<sup>(1)</sup>Fill weights based on specific gravity of 0.99.

<sup>(2)</sup>Low speed <500000 dN.

<sup>(3)</sup>High speed > 500000 dN.

<sup>(4)</sup>For ceramic ball complements, use 120 percent of speeds shown.

<sup>(5)</sup>For other mounting arrangement configurations, refer to the engineering section on permissible speed calculation methods.

**EXTRA-LIGHT ISO 10 SERIES**  
**2(3)MV/MM9100WI (7000C(E)-...-P4/P4S)**  
**HIGH PRECISION MV**

Running accuracy, performance and dimensional controls conform to ABEC 7 (ISO P4) requirements.

**SUPER PRECISION MM**

Running accuracy and performance meet ABEC 9 (ISO P2) levels. Other features conform to ABEC 7 (ISO P4) requirements.

**WI CONSTRUCTION**

- Incorporates low shoulder on non-thrust side of both inner and outer rings.
- Balls separated by one-piece cage piloted against a ground thrust shoulder land of the outer ring.
- Optional one-piece cage piloted on the ball available with MV (P4) product.

Bearing Number 15° C/2 <sup>(3)</sup> or 25° E/3 <sup>(4)</sup>	d Bore	D O.D.	C Width <sup>(1)</sup>	Ball Qty. x Dia.	Bearing Wt.	15° (C/2) Load Ratings						25° (E/3) Load Ratings					
						Steel Ball			Ceramic Ball			Steel Ball			Ceramic Ball		
						C <sub>0</sub> Static	C <sub>e</sub> Dynamic	Speed Rating <sup>(N<sub>g</sub>)</sup>	C <sub>0</sub> Static	C <sub>e</sub> Dynamic	Speed Rating <sup>(N<sub>g</sub>)</sup>	C <sub>0</sub> Static	C <sub>e</sub> Dynamic	Speed Rating <sup>(N<sub>g</sub>)</sup>	C <sub>0</sub> Static	C <sub>e</sub> Dynamic	Speed Rating <sup>(N<sub>g</sub>)</sup>
N lbs.	N lbs.	RPM	N lbs.	N lbs.	RPM	N lbs.	N lbs.	RPM	N lbs.	N lbs.	RPM	N lbs.	N lbs.	RPM			
9100WI	10	26	8	8 x 4.8	0.018	2200	5400	68500	1958	5400	82200	2100	5300	61700	1869	5300	74040
7000	0.3937	1.0236	0.3150	8 x 3/16	0.04	490	1210	68500	436	1210	82200	480	1190	61700	427	1190	74040
9101WI	12	28	8	10 x 4.8	0.020	2900	6400	57300	2581	6400	68760	2800	6200	51600	2492	6200	61920
7001	0.4724	1.1024	0.3150	10 x 3/16	0.04	650	1430	57300	579	1430	68760	630	1390	51600	561	1390	61920
9102WI	15	32	9	12 x 4.8	0.030	3600	7300	48600	3204	7300	58320	3530	7020	43700	3142	7020	52440
7002	0.5906	1.2598	0.3543	12 x 3/16	0.07	820	1630	48600	730	1630	58320	790	1580	43700	703	1580	52440
9103WI	17	35	10	11 x 4.8	0.038	3400	6800	43100	3026	6800	51720	3300	6600	38800	2937	6600	46560
7003	0.6693	1.3780	0.3937	11 x 3/16	0.08	770	1530	43100	685	1530	51720	750	1480	38800	668	1480	46560
9104WI	20	42	12	11 x 6.4	0.067	6000	11600	37100	5340	11600	44520	5700	11100	33400	5073	11100	40080
7004	0.7874	1.6535	0.4724	11 x 1/4	0.15	1350	2600	37100	1202	2600	44520	1290	2500	33400	1148	2500	40080
9105WI	25	47	12	13 x 6.4	0.077	7400	12900	30900	6586	12900	37080	7100	12300	27800	6319	12300	33360
7005	0.9843	1.8504	0.4724	13 x 1/4	0.17	1660	2900	30900	1477	2900	37080	1590	2770	27800	1415	2770	33360
9106WI	30	55	13	14 x 7.1	0.113	10300	16800	25500	9167	16800	30600	9900	16000	23000	8811	16000	27600
7006	1.1811	2.1654	0.5118	14 x 9/32	0.25	2310	3770	25500	2056	3770	30600	2200	3600	23000	1958	3600	27600
9107WI	35	62	14	15 x 7.9	0.151	13700	21200	22600	12193	21200	27120	13000	20200	20300	11570	20200	24360
7007	1.3780	2.4409	0.5512	15 x 3/16	0.33	3070	4760	22600	2732	4760	27120	2930	4540	20300	2608	4540	24360
9108WI	40	68	15	16 x 7.9	0.187	14900	21900	19900	13261	21900	23880	14200	20800	17900	12638	20800	21480
7008	1.5748	2.6772	0.5906	16 x 3/16	0.41	3360	4920	19900	2990	4920	23880	3190	4670	17900	2839	4670	21480
9109WI	45	75	16	17 x 8.7	0.240	19300	27000	17900	17177	27000	21480	18300	25600	16100	16287	25600	19320
7009	1.7717	2.9528	0.6299	17 x 1/2	0.53	4330	6080	17900	3854	6080	21480	4110	5760	16100	3658	5760	19320
9110WI	50	80	16	18 x 8.7	0.258	20800	27900	16300	18512	27900	19560	19700	26300	14700	17533	26300	17640
7010	1.9685	3.1496	0.6299	18 x 1/2	0.57	4670	6270	16300	4156	6270	19560	4430	5910	14700	3943	5910	17640
9111WI	55	90	18	18 x 10.3	0.383	28600	37800	14700	25454	37800	17640	27200	35900	13200	24208	35900	15840
7011	2.1654	3.5433	0.7087	18 x 3/2	0.84	6420	8500	14700	5714	8500	17640	6110	8080	13200	5438	8080	15840
9112WI	60	95	18	19 x 10.3	0.409	30500	38800	13600	27145	38800	16320	33200	36900	12200	29548	36900	14640
7012	2.3622	3.7402	0.7087	19 x 3/2	0.90	6860	8730	13600	6105	8730	16320	7470	8290	12200	6648	8290	14640
9113WI	65	100	18	20 x 10.3	0.435	32600	39800	12700	29014	39800	15240	31000	37700	11400	27590	37700	13680
7013	2.5591	3.9370	0.7087	20 x 3/2	0.96	7330	8950	12700	6524	8950	15240	6970	8480	11400	6203	8480	13680
9114WI	70	110	20	19 x 11.9	0.604	40700	50300	11700	36223	50300	14040	38800	47600	10500	34532	47600	12600
7014	2.7559	4.3307	0.7874	19 x 1 1/2	1.33	9150	11300	11700	8144	11300	14040	8730	10700	10500	7770	10700	12600
9115WI	75	115	20	20 x 11.9	0.638	43500	51600	11000	38715	51600	13200	41200	48900	9900	36668	48900	11880
7015	2.9528	4.5276	0.7874	20 x 1 1/2	1.41	9790	11600	11000	8713	11600	13200	9260	11000	9900	8241	11000	11880

<sup>(N<sub>g</sub>)</sup>For a single, grease-lubricated, spring-preloaded bearing. This value to be used in permissible operating speed (Sp) calculation.

<sup>(1)</sup>Width tolerance of preloaded bearing set +0.000/-0.254 mm (+0.0000/-0.0100 in.).

<sup>(2)</sup>Fill weights based upon specific gravity of 0.99.

<sup>(3)</sup>C is ISO designation for 15° contact angle, 2 is Timken designation for 15° contact angle.

<sup>(4)</sup>E is ISO designation for 25° contact angle, 3 is Timken designation for 25° contact angle.

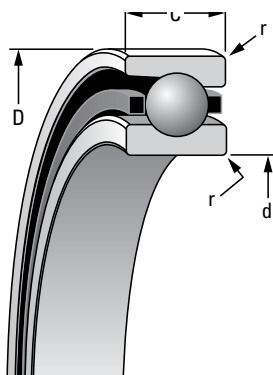

r Rad. <sup>(2)</sup>	Suggested Shoulder Diameters				Shaft Diameter		Mounting Fits		Fixed				Floating			
	Shaft		Housing						Housing Bore (Stationary)		Mounting Fits		Housing Bore (Stationary)		Mounting Fits	
	Max.	Min.	Max.	Min.	Max.	Min.	Loose	Tight	Max.	Min.	Tight	Loose	Max.	Min.	Loose	Loose
mm in.	mm in.	mm in.	mm in.	mm in.	mm in.	mm in.	mm in.	mm in.	mm in.	mm in.	mm in.	mm in.	mm in.	mm in.	mm in.	mm in.
<b>0.3</b>	<b>13.6</b>	<b>13.3</b>	<b>23.2</b>	<b>23.0</b>	<b>10.000</b>	<b>9.995</b>	<b>0.005</b>	<b>0.004</b>	<b>26.005</b>	<b>26.000</b>	<b>0.000</b>	<b>0.010</b>	<b>26.010</b>	<b>26.005</b>	<b>0.015</b>	<b>0.005</b>
0.012	0.54	0.53	0.92	0.91	0.39370	0.39350	0.00020	0.00015	1.02380	1.02360	0.00000	0.00040	1.02400	1.02380	0.00060	0.00020
<b>0.3</b>	<b>16.1</b>	<b>15.9</b>	<b>25.5</b>	<b>25.3</b>	<b>12.000</b>	<b>11.995</b>	<b>0.005</b>	<b>0.004</b>	<b>28.005</b>	<b>28.000</b>	<b>0.000</b>	<b>0.010</b>	<b>28.010</b>	<b>28.005</b>	<b>0.015</b>	<b>0.005</b>
0.012	0.64	0.63	1.01	1.00	0.47240	0.47220	0.00020	0.00015	1.10260	1.10240	0.00000	0.00040	1.10280	1.10260	0.00060	0.00020
<b>0.3</b>	<b>19.2</b>	<b>18.9</b>	<b>28.6</b>	<b>28.3</b>	<b>15.000</b>	<b>14.995</b>	<b>0.005</b>	<b>0.004</b>	<b>32.005</b>	<b>32.000</b>	<b>0.000</b>	<b>0.011</b>	<b>32.010</b>	<b>32.005</b>	<b>0.016</b>	<b>0.005</b>
0.012	0.76	0.75	1.13	1.12	0.59060	0.59040	0.00020	0.00015	1.26000	1.25980	0.00000	0.00045	1.26020	1.26000	0.00070	0.00020
<b>0.3</b>	<b>21.7</b>	<b>21.5</b>	<b>31.1</b>	<b>30.9</b>	<b>17.000</b>	<b>16.995</b>	<b>0.005</b>	<b>0.004</b>	<b>35.006</b>	<b>35.000</b>	<b>0.000</b>	<b>0.012</b>	<b>35.010</b>	<b>35.005</b>	<b>0.016</b>	<b>0.005</b>
0.012	0.86	0.85	1.23	1.22	0.66930	0.66910	0.00020	0.00015	1.37830	1.37800	0.00000	0.00050	1.37840	1.37820	0.00070	0.00020
<b>0.6</b>	<b>25.0</b>	<b>24.8</b>	<b>37.7</b>	<b>37.5</b>	<b>20.000</b>	<b>19.995</b>	<b>0.005</b>	<b>0.005</b>	<b>42.006</b>	<b>42.000</b>	<b>0.000</b>	<b>0.012</b>	<b>42.010</b>	<b>42.005</b>	<b>0.016</b>	<b>0.005</b>
0.024	0.99	0.98	1.49	1.48	0.78740	0.78720	0.00020	0.00020	1.65380	1.65350	0.00000	0.00050	1.65390	1.65370	0.00070	0.00020
<b>0.6</b>	<b>30.1</b>	<b>29.9</b>	<b>42.6</b>	<b>42.3</b>	<b>25.000</b>	<b>24.995</b>	<b>0.005</b>	<b>0.005</b>	<b>47.006</b>	<b>47.000</b>	<b>0.000</b>	<b>0.012</b>	<b>47.012</b>	<b>47.007</b>	<b>0.018</b>	<b>0.007</b>
0.024	1.19	1.18	1.68	1.67	0.98430	0.98410	0.00020	0.00020	1.85070	1.85040	0.00000	0.00050	1.85090	1.85070	0.00080	0.00030
<b>1.0</b>	<b>36.2</b>	<b>35.9</b>	<b>50.7</b>	<b>50.4</b>	<b>30.000</b>	<b>29.995</b>	<b>0.005</b>	<b>0.005</b>	<b>55.008</b>	<b>55.000</b>	<b>0.000</b>	<b>0.015</b>	<b>55.012</b>	<b>55.007</b>	<b>0.019</b>	<b>0.007</b>
0.039	1.43	1.42	2.00	1.99	1.18110	1.18090	0.00020	0.00020	2.16570	2.16540	0.00000	0.00060	2.16590	2.16570	0.00080	0.00030
<b>1.0</b>	<b>41.2</b>	<b>40.6</b>	<b>56.6</b>	<b>56.1</b>	<b>35.000</b>	<b>34.995</b>	<b>0.005</b>	<b>0.006</b>	<b>62.008</b>	<b>62.000</b>	<b>0.000</b>	<b>0.015</b>	<b>62.012</b>	<b>62.007</b>	<b>0.019</b>	<b>0.007</b>
0.039	1.62	1.60	2.23	2.21	1.37800	1.37780	0.00020	0.00025	2.44120	2.44090	0.00000	0.00060	2.44140	2.44120	0.00080	0.00030
<b>1.0</b>	<b>46.2</b>	<b>45.7</b>	<b>62.2</b>	<b>61.7</b>	<b>40.000</b>	<b>39.995</b>	<b>0.005</b>	<b>0.006</b>	<b>68.008</b>	<b>68.000</b>	<b>0.000</b>	<b>0.015</b>	<b>68.012</b>	<b>68.007</b>	<b>0.019</b>	<b>0.007</b>
0.039	1.82	1.80	2.45	2.43	1.57480	1.57460	0.00020	0.00025	2.67750	2.67720	0.00000	0.00060	2.67770	2.67750	0.00080	0.00030
<b>1.0</b>	<b>51.8</b>	<b>51.3</b>	<b>69.3</b>	<b>68.8</b>	<b>45.000</b>	<b>44.995</b>	<b>0.005</b>	<b>0.006</b>	<b>75.008</b>	<b>75.000</b>	<b>0.000</b>	<b>0.015</b>	<b>75.014</b>	<b>75.009</b>	<b>0.022</b>	<b>0.009</b>
0.039	2.04	2.02	2.73	2.71	1.77170	1.77150	0.00020	0.00025	2.95310	2.95280	0.00000	0.00060	2.95330	2.95310	0.00080	0.00030
<b>1.0</b>	<b>56.6</b>	<b>56.1</b>	<b>74.2</b>	<b>73.7</b>	<b>50.000</b>	<b>49.995</b>	<b>0.005</b>	<b>0.006</b>	<b>80.008</b>	<b>80.000</b>	<b>0.000</b>	<b>0.015</b>	<b>80.012</b>	<b>80.008</b>	<b>0.020</b>	<b>0.008</b>
0.039	2.23	2.21	2.92	2.90	1.96850	1.96830	0.00020	0.00025	3.14990	3.14960	0.00000	0.00060	3.15010	3.14990	0.00080	0.00030
<b>1.0</b>	<b>62.7</b>	<b>62.2</b>	<b>83.3</b>	<b>82.8</b>	<b>55.000</b>	<b>54.995</b>	<b>0.005</b>	<b>0.007</b>	<b>90.008</b>	<b>90.000</b>	<b>0.000</b>	<b>0.016</b>	<b>90.015</b>	<b>90.007</b>	<b>0.023</b>	<b>0.007</b>
0.039	2.47	2.45	3.28	3.26	2.16540	2.16520	0.00020	0.00030	3.54360	3.54330	0.00000	0.00060	3.54390	3.54360	0.00090	0.00030
<b>1.0</b>	<b>67.8</b>	<b>67.3</b>	<b>88.1</b>	<b>87.6</b>	<b>60.000</b>	<b>59.995</b>	<b>0.005</b>	<b>0.007</b>	<b>95.008</b>	<b>95.000</b>	<b>0.000</b>	<b>0.016</b>	<b>95.016</b>	<b>95.009</b>	<b>0.024</b>	<b>0.009</b>
0.039	2.67	2.65	3.47	3.45	2.36220	2.36200	0.00020	0.00030	3.74050	3.74020	0.00000	0.00060	3.74080	3.74050	0.00090	0.00030
<b>1.0</b>	<b>72.6</b>	<b>72.1</b>	<b>93.2</b>	<b>92.7</b>	<b>65.000</b>	<b>64.995</b>	<b>0.005</b>	<b>0.007</b>	<b>100.008</b>	<b>100.000</b>	<b>0.000</b>	<b>0.016</b>	<b>100.018</b>	<b>100.010</b>	<b>0.025</b>	<b>0.010</b>
0.039	2.86	2.84	3.67	3.65	2.55910	2.55890	0.00020	0.00030	3.93730	3.93700	0.00000	0.00060	3.93770	3.93740	0.00100	0.00040
<b>1.0</b>	<b>78.2</b>	<b>77.7</b>	<b>102.4</b>	<b>101.9</b>	<b>70.000</b>	<b>69.995</b>	<b>0.005</b>	<b>0.007</b>	<b>110.008</b>	<b>110.000</b>	<b>0.000</b>	<b>0.016</b>	<b>110.018</b>	<b>110.010</b>	<b>0.025</b>	<b>0.010</b>
0.039	3.08	3.06	4.03	4.01	2.75590	2.75570	0.00020	0.00030	4.33100	4.33070	0.00000	0.00060	4.33140	4.33110	0.00100	0.00040
<b>1.0</b>	<b>83.4</b>	<b>82.7</b>	<b>107.3</b>	<b>106.6</b>	<b>75.005</b>	<b>74.995</b>	<b>0.005</b>	<b>0.012</b>	<b>115.008</b>	<b>115.000</b>	<b>0.000</b>	<b>0.016</b>	<b>115.019</b>	<b>115.011</b>	<b>0.026</b>	<b>0.010</b>
0.039	3.29	3.26	4.23	4.20	2.95300	2.95260	0.00020	0.00050	4.52790	4.52760	0.00000	0.00060	4.52830	4.52800	0.00100	0.00040

*Continued on next page.*

**EXTRA-LIGHT ISO 10 SERIES - continued**  
**2(3)MV/MM9100WI (7000C(E)-...-P4/P4S)**  
**HIGH PRECISION MV**

Running accuracy, performance and dimensional controls conform to ABEC 7 (ISO P4) requirements.

**SUPER PRECISION MM**

Running accuracy and performance meet ABEC 9 (ISO P2) levels. Other features conform to ABEC 7 (ISO P4) requirements.

**WI CONSTRUCTION**

- Incorporates low shoulder on non-thrust side of both inner and outer rings.
- Balls separated by one-piece cage piloted against a ground thrust shoulder land of the outer ring.
- Optional one-piece cage piloted on the ball available with MV (P4) product.

Bearing Number 15° C/2 <sup>(3)</sup> or 25° E/3 <sup>(4)</sup>	d Bore	D O.D.	C Width <sup>(1)</sup>	Ball Qty. x Dia.	Bearing Wt.	15° (C/2) Load Ratings						25° (E/3) Load Ratings					
						Steel Ball			Ceramic Ball			Steel Ball			Ceramic Ball		
						C <sub>0</sub> Static	C <sub>e</sub> Dynamic	Speed Rating <sup>(N<sub>g</sub>)</sup>	C <sub>0</sub> Static	C <sub>e</sub> Dynamic	Speed Rating <sup>(N<sub>g</sub>)</sup>	C <sub>0</sub> Static	C <sub>e</sub> Dynamic	Speed Rating <sup>(N<sub>g</sub>)</sup>	C <sub>0</sub> Static	C <sub>e</sub> Dynamic	Speed Rating <sup>(N<sub>g</sub>)</sup>
mm in.	mm in.	mm in.	mm in.	kg lbs.	N lbs.	N lbs.	RPM	N lbs.	N lbs.	RPM	N lbs.	N lbs.	RPM	N lbs.	N lbs.	RPM	
9116WI 7016	80 3.1496	125 4.9213	22 0.8661	20 x 13.5 20 x 1/2	0.859 1.89	5200 12400	64900 14600	10300 10300	49128 11036	64900 14600	12360 12360	52500 11800	61400 13800	9300 9300	46725 10502	61400 13800	11160 11160
9117WI 7017	85 3.3465	130 5.1181	22 0.8661	21 x 13.5 21 x 1/2	0.901 1.99	58700 13200	66700 15000	9700 9700	52243 11748	66700 15000	11640 11640	55600 12500	63200 14200	8700 8700	49484 11125	63200 14200	10440 10440
9118WI 7018	90 3.5433	140 5.5118	24 0.9449	20 x 15.1 20 x 1/2	1.170 2.58	68900 15500	79600 17900	9200 9200	61321 13795	79600 17900	11040 11040	65800 14800	75200 16900	8300 8300	58562 13172	75200 16900	9960 9960
9119WI 7019	95 3.7402	145 5.7087	24 0.9449	21 x 15.1 21 x 1/2	1.222 2.69	73400 16500	81400 18300	8700 8700	65326 14685	81400 18300	10440 10440	69400 15600	77400 17400	7800 7800	61766 13884	77400 17400	9360 9360
9120WI 7020	100 3.9370	150 5.9055	24 0.9449	22 x 15.1 22 x 1/2	1.299 2.86	77400 17400	83600 18800	8300 8300	68886 15486	83600 18800	9960 9960	73400 16500	79200 17800	7500 7500	65326 14685	79200 17800	9000 9000
9121WI 7021	105 4.1339	160 6.2992	26 1.0236	21 x 16.7 21 x 2/3	1.617 3.57	89400 20100	97900 22000	7900 7900	79566 17889	97900 22000	9480 9480	84500 19000	92100 20700	7100 7100	75205 16910	92100 20700	8520 8520
9122WI 7022	110 4.3307	170 6.6929	28 1.1024	22 x 17.5 22 x 1/2	2.043 4.50	102700 23100	109400 24600	7500 7500	91403 20559	109400 24600	9000 9000	97400 21900	103200 23200	6800 6800	86686 19491	103200 23200	8160 8160
9124WI 7024	120 4.7244	180 7.0866	28 1.1024	23 x 17.5 23 x 1/2	2.180 4.81	108500 24400	111200 25000	6900 6900	96565 21716	111200 25000	8280 8280	103200 23200	105000 23600	6200 6200	91848 20648	105000 23600	7440 7440
9126WI 7026	130 5.1181	200 7.8740	33 1.2992	21 x 20.6 21 x 1/2	3.273 7.21	137000 30800	143200 32200	6400 6400	121930 27412	143200 32200	7680 7680	129900 29200	135700 30500	5800 5800	115611 2988	135700 30500	6960 6960
9128WI 7028	140 5.5118	210 8.2677	33 1.2992	22 x 20.6 22 x 1/2	3.454 7.62	145000 32600	146300 32900	5900 5900	129050 29014	146300 32900	7080 7080	137400 30900	138300 31100	5300 5300	122286 27501	138300 31100	6360 6360
9130WI 7030	150 5.9055	225 8.8583	35 1.3780	22 x 22.2 22 x 7/8	4.200 9.26	168100 37800	167200 37600	5600 5600	149609 33642	167200 37600	6720 6720	159200 35800	157900 35500	5000 5000	141688 31862	157900 35500	6000 6000
9132WI 7032	160 6.2992	240 9.4488	38 1.4961	22 x 23.8 22 x 1/2	5.188 11.44	192600 43300	189500 42600	5200 5200	171414 38537	189500 42600	6240 6240	182800 41100	179300 40300	4700 4700	162692 36579	179300 40300	5640 5640
9134WI 7034	170 6.6929	260 10.2362	42 1.6535	22 x 27.0 22 x 1/2	6.999 15.43	245500 55200	234000 52600	4900 4900	218495 49128	234000 52600	5880 5880	232600 52300	221100 49700	4400 4400	207014 46547	221100 49700	5280 5280
9136WI 7036	180 7.0866	280 11.0236	46 1.8110	20 x 27.0 20 x 1/2	9.250 20.40	276200 62100	258400 58100	4600 4600	245818 55269	258400 58100	5520 5520	262400 59000	244400 55000	4200 4200	233536 52510	244400 55000	5040 5040
9140WI 7040	200 7.8740	310 12.2047	51 2.0079	20 x 33.3 20 x 1/2	12.148 26.78	337200 75800	296700 66700	4100 4100	300108 67462	296700 66700	4920 4920	321100 72200	281100 63200	3700 3700	285779 64258	281100 63200	4440 4440

<sup>(N<sub>g</sub>)</sup>For a single, grease-lubricated, spring-preloaded bearing. This value to be used in permissible operating speed (Sp) calculation.

<sup>(1)</sup>Width tolerance of preloaded bearing set +0.000/-0.254 mm (+0.0000/-0.0100 in.).

<sup>(2)</sup>Fill weights based upon specific gravity of 0.99.

<sup>(3)</sup>C is ISO designation for 15° contact angle, 2 is Timken designation for 15° contact angle.

<sup>(4)</sup>E is ISO designation for 25° contact angle, 3 is Timken designation for 25° contact angle.

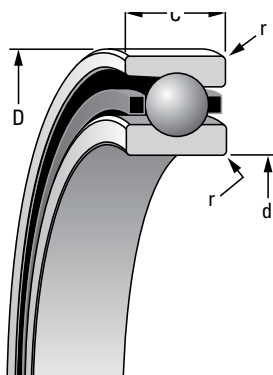

r Rad. <sup>(2)</sup>	Suggested Shoulder Diameters				Shaft Diameter				Fixed				Floating			
	Shaft		Housing						Housing Bore (Stationary)		Mounting Fits		Housing Bore (Stationary)		Mounting Fits	
	Max.	Min.	Max.	Min.	Max.	Min.	Loose	Tight	Max.	Min.	Tight	Loose	Max.	Min.	Loose	Loose
mm in.	mm in.	mm in.	mm in.	mm in.	mm in.	mm in.	mm in.	mm in.	mm in.	mm in.	mm in.	mm in.	mm in.	mm in.	mm in.	mm in.
<b>1.0</b> 0.039	<b>89.3</b> 3.52	<b>88.5</b> 3.49	<b>116.5</b> 4.59	<b>115.7</b> 4.56	<b>80.005</b> 3.14980	<b>79.995</b> 3.14940	<b>0.005</b> 0.00020	<b>0.012</b> 0.00050	<b>125.008</b> 4.92160	<b>125.000</b> 4.92130	<b>0.000</b> 0.00000	<b>0.017</b> 0.00070	<b>125.021</b> 4.92210	<b>125.011</b> 4.92170	<b>0.030</b> 0.00120	<b>0.011</b> 0.00040
<b>1.0</b> 0.039	<b>94.9</b> 3.74	<b>94.1</b> 3.71	<b>122.1</b> 4.81	<b>121.3</b> 4.78	<b>85.005</b> 3.34670	<b>84.995</b> 3.34630	<b>0.005</b> 0.00020	<b>0.012</b> 0.00050	<b>130.009</b> 5.11850	<b>130.000</b> 5.11810	<b>0.000</b> 0.00000	<b>0.018</b> 0.00070	<b>130.020</b> 5.11890	<b>130.010</b> 5.11850	<b>0.029</b> 0.00110	<b>0.010</b> 0.00040
<b>1.5</b> 0.059	<b>100.5</b> 3.96	<b>99.7</b> 3.93	<b>130.9</b> 5.16	<b>130.2</b> 5.13	<b>90.005</b> 3.54350	<b>89.995</b> 3.54310	<b>0.005</b> 0.00020	<b>0.013</b> 0.00050	<b>140.009</b> 5.51220	<b>140.000</b> 5.51180	<b>0.000</b> 0.00000	<b>0.018</b> 0.00070	<b>140.020</b> 5.51260	<b>140.010</b> 5.51220	<b>0.029</b> 0.00110	<b>0.010</b> 0.00040
<b>1.5</b> 0.059	<b>105.5</b> 4.16	<b>104.8</b> 4.13	<b>135.8</b> 5.35	<b>135.0</b> 5.32	<b>95.005</b> 3.74040	<b>94.995</b> 3.74000	<b>0.005</b> 0.00020	<b>0.013</b> 0.00050	<b>145.009</b> 5.70910	<b>145.000</b> 5.70870	<b>0.000</b> 0.00000	<b>0.018</b> 0.00070	<b>145.021</b> 5.70950	<b>145.011</b> 5.70910	<b>0.030</b> 0.00110	<b>0.011</b> 0.00040
<b>1.5</b> 0.059	<b>110.6</b> 4.36	<b>109.9</b> 4.33	<b>140.8</b> 5.55	<b>140.1</b> 5.52	<b>100.005</b> 3.93720	<b>99.995</b> 3.93680	<b>0.005</b> 0.00020	<b>0.013</b> 0.00050	<b>150.009</b> 5.90590	<b>150.000</b> 5.90550	<b>0.000</b> 0.00000	<b>0.018</b> 0.00070	<b>150.023</b> 5.90640	<b>150.012</b> 5.90600	<b>0.032</b> 0.00120	<b>0.012</b> 0.00050
<b>2.0</b> 0.079	<b>116.5</b> 4.59	<b>115.7</b> 4.56	<b>150.0</b> 5.91	<b>149.2</b> 5.88	<b>105.005</b> 4.13410	<b>104.995</b> 4.13370	<b>0.005</b> 0.00020	<b>0.013</b> 0.00050	<b>160.009</b> 6.29960	<b>160.000</b> 6.29920	<b>0.000</b> 0.00000	<b>0.022</b> 0.00080	<b>160.022</b> 6.30010	<b>160.012</b> 6.29970	<b>0.033</b> 0.00130	<b>0.012</b> 0.00050
<b>2.0</b> 0.079	<b>123.1</b> 4.85	<b>122.3</b> 4.82	<b>158.4</b> 6.24	<b>157.6</b> 6.21	<b>110.005</b> 4.33090	<b>109.995</b> 4.33050	<b>0.005</b> 0.00020	<b>0.013</b> 0.00050	<b>170.010</b> 6.69330	<b>170.000</b> 6.69290	<b>0.000</b> 0.00000	<b>0.020</b> 0.00080	<b>170.022</b> 6.69380	<b>170.012</b> 6.69340	<b>0.032</b> 0.00130	<b>0.012</b> 0.00050
<b>2.0</b> 0.079	<b>133.2</b> 5.25	<b>132.5</b> 5.22	<b>168.3</b> 6.63	<b>167.5</b> 6.60	<b>120.005</b> 4.72460	<b>119.995</b> 4.72420	<b>0.005</b> 0.00020	<b>0.013</b> 0.00050	<b>180.010</b> 7.08700	<b>180.000</b> 7.08660	<b>0.000</b> 0.00000	<b>0.020</b> 0.00080	<b>180.022</b> 7.08750	<b>180.012</b> 7.08710	<b>0.032</b> 0.00130	<b>0.012</b> 0.00050
<b>2.0</b> 0.079	<b>144.9</b> 5.71	<b>144.2</b> 5.68	<b>186.6</b> 7.35	<b>185.8</b> 7.32	<b>130.005</b> 5.11830	<b>129.995</b> 5.11790	<b>0.005</b> 0.00020	<b>0.015</b> 0.00060	<b>200.011</b> 7.87450	<b>200.000</b> 7.87400	<b>0.000</b> 0.00000	<b>0.022</b> 0.00090	<b>200.025</b> 7.87500	<b>200.015</b> 7.87460	<b>0.036</b> 0.00150	<b>0.015</b> 0.00060
<b>2.0</b> 0.079	<b>155.1</b> 6.11	<b>154.3</b> 6.08	<b>196.5</b> 7.74	<b>195.7</b> 7.71	<b>140.005</b> 5.51200	<b>139.995</b> 5.51160	<b>0.005</b> 0.00020	<b>0.015</b> 0.00060	<b>210.011</b> 8.26820	<b>210.000</b> 8.26770	<b>0.000</b> 0.00000	<b>0.022</b> 0.00090	<b>210.025</b> 8.26870	<b>210.015</b> 8.26830	<b>0.036</b> 0.00150	<b>0.015</b> 0.00060
<b>2.0</b> 0.079	<b>166.0</b> 6.54	<b>165.2</b> 6.51	<b>210.7</b> 8.30	<b>209.9</b> 8.27	<b>150.005</b> 5.90570	<b>149.995</b> 5.90530	<b>0.005</b> 0.00020	<b>0.015</b> 0.00060	<b>225.011</b> 8.85880	<b>225.000</b> 8.85830	<b>0.000</b> 0.00000	<b>0.022</b> 0.00090	<b>225.025</b> 8.85930	<b>225.015</b> 8.85890	<b>0.036</b> 0.00150	<b>0.015</b> 0.00060
<b>2.0</b> 0.079	<b>176.9</b> 6.97	<b>176.2</b> 6.94	<b>224.7</b> 8.85	<b>223.9</b> 8.82	<b>160.005</b> 6.29940	<b>159.995</b> 6.29900	<b>0.005</b> 0.00020	<b>0.015</b> 0.00060	<b>240.011</b> 9.44930	<b>240.000</b> 9.44880	<b>0.000</b> 0.00000	<b>0.022</b> 0.00090	<b>240.025</b> 9.45000	<b>240.015</b> 9.44940	<b>0.041</b> 0.00160	<b>0.018</b> 0.00060
<b>2.0</b> 0.079	<b>188.6</b> 7.43	<b>187.8</b> 7.40	<b>242.7</b> 9.56	<b>241.9</b> 9.53	<b>170.005</b> 6.69310	<b>169.995</b> 6.69270	<b>0.005</b> 0.00020	<b>0.015</b> 0.00060	<b>260.011</b> 10.23670	<b>260.000</b> 10.23620	<b>0.000</b> 0.00000	<b>0.024</b> 0.00100	<b>260.030</b> 10.23750	<b>260.015</b> 10.23700	<b>0.044</b> 0.00180	<b>0.018</b> 0.00080
<b>2.0</b> 0.079	<b>200.5</b> 7.90	<b>199.8</b> 7.87	<b>261.0</b> 10.28	<b>260.2</b> 10.25	<b>180.008</b> 7.08690	<b>179.993</b> 7.08630	<b>0.007</b> 0.00030	<b>0.018</b> 0.00070	<b>280.013</b> 11.02410	<b>280.000</b> 11.02360	<b>0.000</b> 0.00000	<b>0.026</b> 0.00100	<b>280.031</b> 11.02490	<b>280.018</b> 11.02440	<b>0.044</b> 0.00180	<b>0.018</b> 0.00080
<b>2.0</b> 0.079	<b>222.4</b> 8.76	<b>221.6</b> 8.73	<b>289.2</b> 11.39	<b>288.4</b> 11.36	<b>200.008</b> 7.87430	<b>199.993</b> 7.87370	<b>0.007</b> 0.00030	<b>0.019</b> 0.00080	<b>310.013</b> 12.20520	<b>310.000</b> 12.20470	<b>0.000</b> 0.00000	<b>0.026</b> 0.00100	<b>310.031</b> 12.20600	<b>310.018</b> 12.20550	<b>0.044</b> 0.00180	<b>0.018</b> 0.00080

**EXTRA-LIGHT ISO 10 SERIES**  
**2MV/MM9100WI (7000C-...-P4/P4S)**  
**DUPLEX PERFORMANCE DATA**

Bearing Number	Preload				Axial Stiffness <sup>(1)</sup>				Radial Stiffness <sup>(1)</sup>				Spacer Offsets <sup>(1)</sup>		
	DUX X-light	DUL Light	DUM Med.	DUH Heavy	X-light	Light	Med.	Heavy	X-light	Light	Med.	Heavy	X-light to Light	Light to Med.	Med. to Heavy
	N lbs.	N lbs.	N lbs.	N lbs.	N/μm 10 <sup>6</sup> lbs./in.	N/μm 10 <sup>6</sup> lbs./in.	N/μm 10 <sup>6</sup> lbs./in.	N/μm 10 <sup>6</sup> lbs./in.	N/μm 10 <sup>6</sup> lbs./in.	N/μm 10 <sup>6</sup> lbs./in.	N/μm 10 <sup>6</sup> lbs./in.	N/μm 10 <sup>6</sup> lbs./in.	μm in.	μm in.	μm in.
2MV/MM9100WICR 7000C-T-P4/P4S	— —	<b>13</b> 3	<b>25</b> 6	<b>55</b> 12	<b>14.13</b> 0.081	<b>16.42</b> 0.094	<b>21.51</b> 0.123	<b>28.51</b> 0.163	— —	<b>65.66</b> 0.375	<b>83.78</b> 0.479	<b>105.29</b> 0.602	<b>1.27</b> 0.00005	<b>2.79</b> 0.00011	<b>4.32</b> 0.00017
2MV/MM9101WICR 7001C-T-P4/P4S	— —	<b>20</b> 5	<b>45</b> 10	<b>90</b> 20	<b>18.89</b> 0.108	<b>22.91</b> 0.131	<b>30.08</b> 0.172	<b>40.23</b> 0.230	— —	<b>91.11</b> 0.521	<b>115.29</b> 0.659	<b>144.38</b> 0.826	<b>1.78</b> 0.00007	<b>3.30</b> 0.00013	<b>5.08</b> 0.00020
2MV/MM9102WICR 7002C-T-P4/P4S	— —	<b>20</b> 5	<b>65</b> 15	<b>130</b> 30	<b>20.11</b> 0.115	<b>24.31</b> 0.139	<b>37.60</b> 0.215	<b>50.72</b> 0.290	— —	<b>96.88</b> 0.554	<b>140.41</b> 0.803	<b>175.20</b> 1.002	<b>1.52</b> 0.00006	<b>5.84</b> 0.00023	<b>6.10</b> 0.00024
2MV/MM9103WICR 7003C-T-P4/P4S	— —	<b>20</b> 5	<b>90</b> 20	<b>160</b> 35	<b>20.11</b> 0.115	<b>24.31</b> 0.139	<b>42.50</b> 0.243	<b>54.39</b> 0.311	— —	<b>96.89</b> 0.554	<b>154.07</b> 0.881	<b>183.85</b> 1.051	<b>1.52</b> 0.00006	<b>7.87</b> 0.00031	<b>5.59</b> 0.00022
2MV/MM9104WICR 7004C-T-P4/P4S	— —	<b>45</b> 10	<b>90</b> 20	<b>180</b> 40	<b>21.00</b> 0.120	<b>27.81</b> 0.159	<b>37.25</b> 0.213	<b>50.72</b> 0.290	— —	<b>144.78</b> 0.828	<b>182.61</b> 1.044	<b>228.09</b> 1.304	<b>3.56</b> 0.00014	<b>5.33</b> 0.00021	<b>8.13</b> 0.00032
2MV/MM9105WICR 7005C-T-P4/P4S	— —	<b>45</b> 10	<b>110</b> 25	<b>270</b> 60	<b>28.16</b> 0.161	<b>30.78</b> 0.176	<b>45.12</b> 0.258	<b>67.16</b> 0.384	— —	<b>161.42</b> 0.923	<b>219.81</b> 1.257	<b>290.47</b> 1.661	<b>1.27</b> 0.00005	<b>7.11</b> 0.00028	<b>11.18</b> 0.00044
2MV/MM9106WICR 7006C-T-P4/P4S	— —	<b>65</b> 15	<b>130</b> 30	<b>330</b> 75	<b>30.26</b> 0.173	<b>35.68</b> 0.204	<b>47.92</b> 0.274	<b>73.46</b> 0.420	— —	<b>202.87</b> 1.160	<b>256.21</b> 1.465	<b>343.52</b> 1.964	<b>2.79</b> 0.00011	<b>6.35</b> 0.00025	<b>13.21</b> 0.00052
2MV/MM9107WICR 7007C-T-P4/P4S	— —	<b>90</b> 20	<b>220</b> 50	<b>400</b> 90	<b>33.93</b> 0.194	<b>43.03</b> 0.246	<b>63.66</b> 0.364	<b>83.78</b> 0.479	— —	<b>242.71</b> 1.388	<b>329.53</b> 1.884	<b>397.44</b> 2.272	<b>4.06</b> 0.00016	<b>9.91</b> 0.00039	<b>9.65</b> 0.00038
2MV/MM9108WICR 7008C-T-P4/P4S	— —	<b>90</b> 20	<b>220</b> 50	<b>440</b> 100	<b>38.65</b> 0.221	<b>44.60</b> 0.255	<b>65.94</b> 0.377	<b>91.12</b> 0.521	— —	<b>253.13</b> 1.447	<b>344.22</b> 1.968	<b>429.40</b> 2.455	<b>2.54</b> 0.00010	<b>9.65</b> 0.00038	<b>11.43</b> 0.00045
2MV/MM9109WICR 7009C-T-P4/P4S	— —	<b>130</b> 30	<b>270</b> 60	<b>560</b> 125	<b>41.98</b> 0.240	<b>54.22</b> 0.310	<b>73.11</b> 0.418	<b>103.19</b> 0.590	— —	<b>312.77</b> 1.788	<b>394.21</b> 2.254	<b>498.45</b> 2.850	<b>5.08</b> 0.00020	<b>8.38</b> 0.00033	<b>13.21</b> 0.00052
2MV/MM9110WICR 7010C-T-P4/P4S	<b>89</b> 20	<b>130</b> 30	<b>270</b> 60	<b>670</b> 150	<b>45.65</b> 0.261	<b>55.97</b> 0.320	<b>75.38</b> 0.431	<b>116.13</b> 0.664	<b>281.29</b> 1.606	<b>324.72</b> 1.857	<b>409.67</b> 2.342	<b>548.84</b> 3.138	<b>4.32</b> 0.00017	<b>8.13</b> 0.00032	<b>16.76</b> 0.00066
2MV/MM9111WICR 7011C-T-P4/P4S	<b>110</b> 25	<b>160</b> 35	<b>330</b> 75	<b>670</b> 150	<b>52.99</b> 0.303	<b>62.61</b> 0.358	<b>86.23</b> 0.493	<b>118.23</b> 0.676	<b>316.97</b> 1.810	<b>358.41</b> 2.049	<b>464.50</b> 2.656	<b>581.11</b> 3.323	<b>3.81</b> 0.00015	<b>9.65</b> 0.00038	<b>12.95</b> 0.00051
2MV/MM9112WICR 7012C-T-P4/P4S	<b>110</b> 25	<b>180</b> 40	<b>330</b> 75	<b>890</b> 200	<b>56.49</b> 0.323	<b>68.21</b> 0.390	<b>88.85</b> 0.508	<b>139.75</b> 0.799	<b>327.57</b> 1.871	<b>389.08</b> 2.225	<b>481.62</b> 2.754	<b>660.30</b> 3.775	<b>4.32</b> 0.00017	<b>7.87</b> 0.00031	<b>19.56</b> 0.00077
2MV/MM9113WICR 7013C-T-P4/P4S	<b>110</b> 25	<b>220</b> 50	<b>440</b> 100	<b>890</b> 200	<b>60.17</b> 0.344	<b>77.13</b> 0.441	<b>103.89</b> 0.594	<b>143.42</b> 0.820	<b>337.69</b> 1.928	<b>434.73</b> 2.486	<b>547.87</b> 3.133	<b>683.95</b> 3.911	<b>5.84</b> 0.00023	<b>9.91</b> 0.00039	<b>14.48</b> 0.00057
2MV/MM9114WICR 7014C-T-P4/P4S	<b>130</b> 30	<b>270</b> 60	<b>560</b> 125	<b>1110</b> 250	<b>62.44</b> 0.357	<b>83.43</b> 0.477	<b>114.03</b> 0.652	<b>157.24</b> 0.899	<b>363.37</b> 2.075	<b>469.41</b> 2.684	<b>600.03</b> 3.431	<b>749.06</b> 4.283	<b>7.62</b> 0.00030	<b>11.68</b> 0.00046	<b>16.51</b> 0.00065
2MV/MM9115WICR 7015C-T-P4/P4S	<b>130</b> 30	<b>270</b> 60	<b>560</b> 125	<b>1220</b> 275	<b>66.81</b> 0.382	<b>85.88</b> 0.491	<b>117.36</b> 0.671	<b>169.13</b> 0.967	<b>374.14</b> 2.136	<b>485.42</b> 2.775	<b>621.10</b> 3.551	<b>799.47</b> 4.571	<b>6.60</b> 0.00026	<b>11.43</b> 0.00045	<b>18.54</b> 0.00073

<sup>(1)</sup>For DB or DF arrangements only. For other mounting arrangements, contact your Timken representative.



**MOUNTING ARRANGEMENTS**

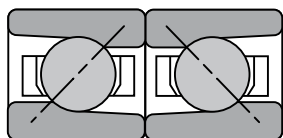

**Back-to-Back  
DB**

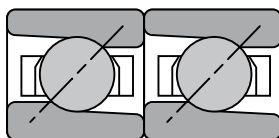

**Tandem  
DT**

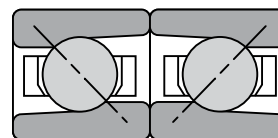

**Face-to-Face  
DF**

Bearing Number	Preload				Axial Stiffness <sup>(1)</sup>				Radial Stiffness <sup>(1)</sup>				Spacer Offsets <sup>(1)</sup>		
	DUX X-light	DUL Light	DUM Med.	DUH Heavy	X-light	Light	Med.	Heavy	X-light	Light	Med.	Heavy	X-light to Light	Light to Med.	Med. to Heavy
	N lbs.	N lbs.	N lbs.	N lbs.	N/μm 10 <sup>6</sup> lbs./in.	N/μm 10 <sup>6</sup> lbs./in.	N/μm 10 <sup>6</sup> lbs./in.	N/μm 10 <sup>6</sup> lbs./in.	N/μm 10 <sup>6</sup> lbs./in.	N/μm 10 <sup>6</sup> lbs./in.	N/μm 10 <sup>6</sup> lbs./in.	N/μm 10 <sup>6</sup> lbs./in.	μm in.	μm in.	μm in.
2MV/MM9116WICR 7016C-T-P4/P4S	160 35	310 70	670 150	1560 350	71.36 0.408	92.87 0.531	128.03 0.732	189.59 1.084	404.91 2.312	529.96 3.030	685.98 3.922	900.40 5.148	7.37 0.00029	12.95 0.00051	22.35 0.00088
2MV/MM9117WICR 7017C-T-P4/P4S	180 40	360 80	780 175	1670 375	75.03 0.429	100.92 0.577	140.97 0.806	201.14 1.150	441.21 2.519	573.22 3.277	745.56 4.263	951.44 5.440	8.38 0.00033	13.97 0.00055	20.83 0.00082
2MV/MM9118WICR 7018C-T-P4/P4S	180 40	440 100	890 200	1780 400	74.16 0.424	105.99 0.606	142.89 0.817	197.64 1.130	436.76 2.494	622.45 3.559	785.34 4.490	981.05 5.609	11.68 0.00046	14.22 0.00056	20.83 0.00082
2MV/MM9119WICR 7019C-T-P4/P4S	200 45	490 110	980 220	1980 445	79.23 0.453	113.34 0.648	153.21 0.876	213.55 1.221	472.40 2.698	664.15 3.797	837.23 4.787	1049.03 5.998	11.94 0.00047	14.73 0.00058	21.84 0.00086
2MV/MM9120WICR 7020C-T-P4/P4S	220 50	560 125	1110 250	2000 450	84.83 0.485	122.95 0.703	166.50 0.952	219.85 1.257	507.88 2.900	715.43 4.091	900.60 5.149	1086.81 6.214	12.70 0.00050	15.24 0.00060	18.29 0.00072
2MV/MM9121WICR 7021C-T-P4/P4S	240 55	600 135	1220 275	2450 550	89.20 0.510	127.68 0.730	173.68 0.993	240.49 1.375	523.56 2.990	736.82 4.213	934.23 5.342	1166.02 6.667	12.95 0.00051	16.51 0.00065	23.62 0.00093
2MV/MM9122WICR 7022C-T-P4/P4S	270 60	670 150	1330 300	2670 600	95.32 0.545	138.17 0.790	186.27 1.065	257.28 1.471	555.90 3.174	792.09 4.529	999.34 5.714	1248.44 7.138	13.72 0.00054	16.51 0.00065	24.13 0.00095
2MV/MM9124WICR 7024C-T-P4/P4S	290 65	780 175	1560 350	2890 650	102.84 0.588	151.29 0.865	204.63 1.170	273.72 1.565	590.28 3.371	859.91 4.917	1082.79 6.191	1319.88 7.547	14.99 0.00059	17.53 0.00069	22.35 0.00088
2MV/MM9126WICR 7026C-T-P4/P4S	330 75	890 200	1780 400	3670 825	105.11 0.601	154.61 0.884	208.48 1.192	292.78 1.674	613.01 3.501	897.71 5.133	1132.37 6.474	1428.16 8.166	17.02 0.00067	19.56 0.00077	30.23 0.00119
2MV/MM9128WICR 7028C-T-P4/P4S	380 85	1000 225	2000 450	3890 875	112.99 0.646	166.85 0.954	225.62 1.290	308.52 1.764	664.59 3.795	963.80 5.511	1214.17 6.942	1501.97 8.588	17.78 0.00070	20.32 0.00080	28.19 0.00111
2MV/MM9130WICR 7030C-T-P4/P4S	440 100	1110 250	2450 550	4450 1000	122.95 0.703	177.87 1.017	250.63 1.433	331.96 1.898	721.78 4.122	1024.34 5.857	1332.00 7.616	1612.33 9.219	17.78 0.00070	24.89 0.00098	27.43 0.00108
2MV/MM9132WICR 7032C-T-P4/P4S	490 110	1330 300	2670 600	5340 1200	130.13 0.744	194.31 1.111	262.35 1.500	363.44 2.078	760.23 4.341	1116.05 6.381	1405.76 8.038	1754.23 10.030	20.83 0.00082	23.37 0.00092	34.04 0.00134
2MV/MM9134WICR 7034C-T-P4/P4S	580 130	1670 375	3340 750	6670 1500	141.49 0.809	215.83 1.234	291.56 1.667	403.84 2.309	839.57 4.794	1264.35 7.229	1592.71 9.106	1987.51 11.364	24.38 0.00096	26.16 0.00103	38.35 0.00151
2MV/MM9136WICR 7036C-T-P4/P4S	670 150	1730 390	3470 780	6940 1560	143.24 0.819	209.53 1.198	282.64 1.616	390.55 2.233	854.72 4.881	1240.93 7.095	1566.02 8.954	1956.50 11.186	24.13 0.00095	28.19 0.00111	41.15 0.00162
2MV/MM9140WICR 7040C-T-P4/P4S	930 210	2220 500	4450 1000	8900 2000	170.00 0.972	240.49 1.375	324.09 1.853	447.92 2.561	1004.58 5.737	1396.79 7.986	1760.98 10.069	2198.74 12.571	25.15 0.00099	31.50 0.00124	45.97 0.00181

**EXTRA-LIGHT ISO 10 SERIES**  
**3MV/MM9100WI (7000E-...-P4/P4S)**  
**DUPLEX PERFORMANCE DATA**

Bearing Number	Preload				Axial Stiffness <sup>(1)</sup>				Radial Stiffness <sup>(1)</sup>				Spacer Offsets <sup>(1)</sup>		
	DUX X-light	DUL Light	DUM Med.	DUH Heavy	X-light	Light	Med.	Heavy	X-light	Light	Med.	Heavy	X-light to Light	Light to Med.	Med. to Heavy
	N lbs.	N lbs.	N lbs.	N lbs.	N/μm 10 <sup>6</sup> lbs./in.	N/μm 10 <sup>6</sup> lbs./in.	N/μm 10 <sup>6</sup> lbs./in.	N/μm 10 <sup>6</sup> lbs./in.	N/μm 10 <sup>6</sup> lbs./in.	N/μm 10 <sup>6</sup> lbs./in.	N/μm 10 <sup>6</sup> lbs./in.	N/μm 10 <sup>6</sup> lbs./in.	μm in.	μm in.	μm in.
3MV/MM9100WICR 7000E-T-P4/P4S	— —	<b>20</b> 5	<b>45</b> 10	<b>90</b> 20	<b>21.51</b> 0.123	<b>30.44</b> 0.174	<b>39.23</b> 0.224	<b>51.11</b> 0.292	— —	<b>63.42</b> 0.363	<b>80.40</b> 0.460	<b>100.86</b> 0.577	<b>0.76</b> 0.00003	<b>1.78</b> 0.00007	<b>2.79</b> 0.00011
3MV/MM9101WICR 7001E-T-P4/P4S	— —	<b>45</b> 10	<b>90</b> 20	<b>180</b> 40	<b>28.68</b> 0.164	<b>45.15</b> 0.258	<b>58.59</b> 0.335	<b>77.10</b> 0.440	— —	<b>93.27</b> 0.533	<b>117.34</b> 0.671	<b>146.46</b> 0.837	<b>1.02</b> 0.00004	<b>2.29</b> 0.00009	<b>3.56</b> 0.00014
3MV/MM9102WICR 7002E-T-P4/P4S	— —	<b>45</b> 10	<b>90</b> 20	<b>180</b> 40	<b>30.61</b> 0.175	<b>50.68</b> 0.289	<b>65.58</b> 0.374	<b>85.94</b> 0.491	— —	<b>99.34</b> 0.568	<b>125.12</b> 0.715	<b>156.34</b> 0.894	<b>1.02</b> 0.00004	<b>3.81</b> 0.00015	<b>4.32</b> 0.00017
3MV/MM9103WICR 7003E-T-P4/P4S	— —	<b>65</b> 15	<b>160</b> 35	<b>220</b> 50	<b>30.61</b> 0.175	<b>55.73</b> 0.318	<b>77.33</b> 0.442	<b>89.38</b> 0.510	— —	<b>113.84</b> 0.651	<b>149.87</b> 0.857	<b>167.71</b> 0.959	<b>1.02</b> 0.00004	<b>5.33</b> 0.00021	<b>3.81</b> 0.00015
3MV/MM9104WICR 7004E-T-P4/P4S	— —	<b>90</b> 20	<b>180</b> 40	<b>330</b> 75	<b>40.4</b> 0.231	<b>66.77</b> 0.381	<b>86.69</b> 0.495	<b>111.16</b> 0.635	— —	<b>137.86</b> 0.788	<b>173.36</b> 0.991	<b>212.00</b> 1.212	<b>2.03</b> 0.00008	<b>3.05</b> 0.00012	<b>4.57</b> 0.00018
3MV/MM9105WICR 7005E-T-P4/P4S	— —	<b>90</b> 20	<b>220</b> 50	<b>400</b> 90	<b>52.99</b> 0.303	<b>74.23</b> 0.424	<b>104.70</b> 0.598	<b>132.20</b> 0.755	— —	<b>153.93</b> 0.880	<b>208.66</b> 1.193	<b>251.77</b> 1.440	<b>0.76</b> 0.00003	<b>3.81</b> 0.00015	<b>6.35</b> 0.00025
3MV/MM9106WICR 7006E-T-P4/P4S	— —	<b>130</b> 30	<b>290</b> 65	<b>530</b> 120	<b>60.52</b> 0.346	<b>90.66</b> 0.518	<b>121.43</b> 0.693	<b>155.04</b> 0.885	— —	<b>195.36</b> 1.117	<b>252.33</b> 1.443	<b>306.97</b> 1.755	<b>1.27</b> 0.00005	<b>3.3</b> 0.00013	<b>7.37</b> 0.00029
3MV/MM9107WICR 7007E-T-P4/P4S	— —	<b>160</b> 35	<b>360</b> 80	<b>710</b> 160	<b>68.74</b> 0.393	<b>103.35</b> 0.590	<b>140.95</b> 0.805	<b>185.62</b> 1.060	— —	<b>222.51</b> 1.272	<b>293.03</b> 1.675	<b>365.86</b> 2.092	<b>2.03</b> 0.00008	<b>5.33</b> 0.00021	<b>5.33</b> 0.00021
3MV/MM9108WICR 7008E-T-P4/P4S	— —	<b>180</b> 40	<b>440</b> 100	<b>760</b> 170	<b>78.01</b> 0.446	<b>113.06</b> 0.646	<b>159.90</b> 0.913	<b>197.67</b> 1.129	— —	<b>243.01</b> 1.389	<b>329.06</b> 1.881	<b>389.76</b> 2.229	<b>1.27</b> 0.00005	<b>5.08</b> 0.0002	<b>6.35</b> 0.00025
3MV/MM9109WICR 7009E-T-P4/P4S	— —	<b>220</b> 50	<b>560</b> 125	<b>980</b> 220	<b>87.97</b> 0.503	<b>131.08</b> 0.749	<b>185.23</b> 1.058	<b>232.10</b> 1.325	— —	<b>280.98</b> 1.607	<b>380.67</b> 2.176	<b>455.96</b> 2.607	<b>2.54</b> 0.0001	<b>4.32</b> 0.00017	<b>7.11</b> 0.00028
3MV/MM9110WICR 7010E-T-P4/P4S	<b>110</b> 25	<b>240</b> 55	<b>670</b> 150	<b>1070</b> 240	<b>109.84</b> 0.628	<b>142.02</b> 0.812	<b>207.61</b> 1.187	<b>250.63</b> 1.433	<b>227.34</b> 1.298	<b>301.39</b> 1.723	<b>419.66</b> 2.399	<b>487.34</b> 2.786	<b>3.81</b> 0.00015	<b>9.65</b> 0.00038	<b>6.86</b> 0.00027
3MV/MM9111WICR 7011E-T-P4/P4S	<b>130</b> 30	<b>330</b> 75	<b>780</b> 175	<b>1330</b> 300	<b>120.33</b> 0.688	<b>163.53</b> 0.935	<b>225.1</b> 1.287	<b>278.97</b> 1.595	<b>253.11</b> 1.445	<b>354.42</b> 2.026	<b>469.41</b> 2.684	<b>557.84</b> 3.190	<b>5.33</b> 0.00021	<b>9.14</b> 0.00036	<b>8.89</b> 0.00035
3MV/MM9112WICR 7012E-T-P4/P4S	<b>160</b> 35	<b>360</b> 80	<b>890</b> 200	<b>1450</b> 325	<b>129.95</b> 0.743	<b>173.33</b> 0.991	<b>245.21</b> 1.402	<b>297.68</b> 1.702	<b>278.69</b> 1.591	<b>375.44</b> 2.147	<b>508.40</b> 2.907	<b>593.68</b> 3.394	<b>5.33</b> 0.00021	<b>10.16</b> 0.0004	<b>8.13</b> 0.00032
3MV/MM9113WICR 7013E-T-P4/P4S	<b>180</b> 40	<b>360</b> 80	<b>890</b> 200	<b>1560</b> 350	<b>140.62</b> 0.804	<b>178.92</b> 1.023	<b>252.91</b> 1.446	<b>316.22</b> 1.808	<b>303.09</b> 1.731	<b>388.33</b> 2.220	<b>526.36</b> 3.010	<b>629.45</b> 3.599	<b>4.32</b> 0.00017	<b>9.91</b> 0.00039	<b>9.4</b> 0.00037
3MV/MM9114WICR 7014E-T-P4/P4S	<b>200</b> 45	<b>440</b> 100	<b>1110</b> 250	<b>2000</b> 450	<b>148.32</b> 0.848	<b>197.64</b> 1.13	<b>278.97</b> 1.595	<b>352.42</b> 2.015	<b>316.28</b> 1.806	<b>423.12</b> 2.419	<b>573.64</b> 3.280	<b>692.20</b> 3.958	<b>5.59</b> 0.00022	<b>11.18</b> 0.00044	<b>11.18</b> 0.00044
3MV/MM9115WICR 7015E-T-P4/P4S	<b>220</b> 50	<b>490</b> 110	<b>1220</b> 275	<b>2110</b> 475	<b>159.16</b> 0.91	<b>211.45</b> 1.209	<b>298.73</b> 1.708	<b>371.31</b> 2.123	<b>340.43</b> 1.944	<b>452.13</b> 2.585	<b>612.48</b> 3.502	<b>729.26</b> 4.170	<b>5.84</b> 0.00023	<b>11.43</b> 0.00045	<b>10.67</b> 0.00042

<sup>(1)</sup>For DB or DF arrangements only. For other mounting arrangements, contact your Timken representative.

**MOUNTING ARRANGEMENTS**

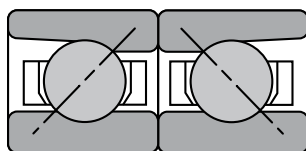

**Back-to-Back  
DB**

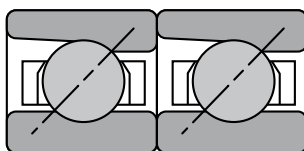

**Tandem  
DT**

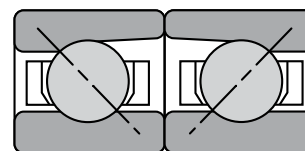

**Face-to-Face  
DF**

Bearing Number	Preload				Axial Stiffness <sup>(1)</sup>				Radial Stiffness <sup>(1)</sup>				Spacer Offsets <sup>(1)</sup>		
	DUX X-light	DUL Light	DUM Med.	DUH Heavy	X-light	Light	Med.	Heavy	X-light	Light	Med.	Heavy	X-light to Light	Light to Med.	Med. to Heavy
	N lbs.	N lbs.	N lbs.	N lbs.	N/μm 10 <sup>6</sup> lbs./in.	N/μm 10 <sup>6</sup> lbs./in.	N/μm 10 <sup>6</sup> lbs./in.	N/μm 10 <sup>6</sup> lbs./in.	N/μm 10 <sup>6</sup> lbs./in.	N/μm 10 <sup>6</sup> lbs./in.	N/μm 10 <sup>6</sup> lbs./in.	N/μm 10 <sup>6</sup> lbs./in.	μm in.	μm in.	μm in.
3MV/MM9116WICR 7016E-T-P4/P4S	240 55	620 140	1560 350	2670 600	170.53 0.975	240.14 1.373	339.13 1.939	420.11 2.402	359.22 2.051	508.19 2.906	688.62 3.937	818.08 4.677	7.37 0.00029	12.7 0.0005	11.68 0.00046
3MV/MM9117WICR 7017E-T-P4/P4S	270 60	670 150	1670 375	2890 650	181.72 1.039	253.95 1.452	358.89 2.052	446.69 2.554	383.57 2.190	537.29 3.072	727.78 4.161	867.49 4.960	7.37 0.00029	12.95 0.00051	12.19 0.00048
3MV/MM9118WICR 7018E-T-P4/P4S	270 65	760 170	1780 400	3340 750	183.99 1.052	262.7 1.502	362.22 2.071	465.06 2.659	394.38 2.252	565.75 3.235	751.98 4.300	919.61 5.258	8.38 0.00033	12.95 0.00051	14.99 0.00059
3MV/MM9119WICR 7019E-T-P4/P4S	290 65	820 185	1980 445	3450 775	193.96 1.109	279.32 1.597	388.98 2.224	485.17 2.774	405.28 2.314	601.34 3.438	804.52 4.600	960.71 5.493	8.89 0.00035	13.72 0.00054	13.46 0.00053
3MV/MM9120WICR 7020E-T-P4/P4S	330 75	850 190	2000 450	3560 800	207.08 1.184	290.51 1.661	401.92 2.298	505.11 2.888	442.97 2.530	625.70 3.578	833.21 4.764	1001.76 5.728	8.13 0.00032	13.21 0.00052	13.72 0.00054
3MV/MM9121WICR 7021E-T-P4/P4S	360 80	960 215	2050 460	4090 920	217.4 1.243	308.35 1.763	409.62 2.342	537.82 3.075	448.80 2.563	652.64 3.732	841.25 4.810	1051.10 6.010	8.89 0.00035	12.19 0.00048	17.27 0.00068
3MV/MM9122WICR 7022E-T-P4/P4S	400 90	1110 250	2670 600	4890 1100	232.62 1.33	337.91 1.932	469.43 2.684	596.76 3.412	487.78 2.785	718.63 4.109	961.43 5.497	1167.28 6.674	9.91 0.00039	15.24 0.0006	16.76 0.00066
3MV/MM9124WICR 7024E-T-P4/P4S	440 100	1220 275	2890 650	5120 1150	251.33 1.437	359.94 2.058	497.59 2.845	624.04 3.568	523.58 2.990	764.45 4.371	1016.78 5.814	1220.33 6.977	10.16 0.0004	15.49 0.00061	15.75 0.00062
3MV/MM9126WICR 7026E-T-P4/P4S	510 115	1510 340	3670 825	6670 1500	259.03 1.481	381.81 2.183	533.1 3.048	676.16 3.866	538.89 3.077	814.82 4.659	1093.67 6.253	1324.03 7.570	12.45 0.00049	18.8 0.00074	19.81 0.00078
3MV/MM9128WICR 7028E-T-P4/P4S	580 130	1560 350	3890 875	6890 1550	277.22 1.585	397.55 2.273	561.08 3.208	704.5 4.028	583.89 3.334	848.49 4.851	1150.30 6.577	1381.06 7.896	11.68 0.00046	19.3 0.00076	19.05 0.00075
3MV/MM9130WICR 7030E-T-P4/P4S	640 145	1780 400	4450 1000	8010 1800	297.16 1.699	428.16 2.448	604.1 3.454	762.74 4.361	617.68 3.527	908.66 5.195	1232.22 7.045	1487.09 8.503	12.45 0.00049	20.57 0.00081	20.83 0.00082
3MV/MM9132WICR 7032E-T-P4/P4S	760 170	2220 500	5340 1200	8900 2000	319.54 1.827	470.66 2.691	655 3.745	802.44 4.588	667.54 3.812	1001.74 5.728	1338.58 7.653	1576.11 9.012	14.73 0.00058	22.1 0.00087	19.56 0.00077
3MV/MM9134WICR 7034E-T-P4/P4S	930 210	2780 625	5780 1300	11560 2600	359.42 2.055	531 3.036	698.73 3.995	918.4 5.251	742.80 4.242	1123.56 6.424	1433.83 8.198	1791.10 10.241	16.51 0.00065	19.56 0.00077	28.45 0.00112
3MV/MM9136WICR 7036E-T-P4/P4S	1020 230	3110 700	6230 1400	12460 2800	358.55 2.05	533.79 3.052	691.9 3.956	908.78 5.196	742.40 4.239	1135.57 6.493	1431.01 8.182	1788.58 10.226	18.54 0.00073	20.32 0.0008	30.9 0.00122
3MV/MM9140WICR 7040E-T-P4/P4S	1250 280	3780 850	8900 2000	16010 3600	395.62 2.262	588.71 3.366	812.24 4.644	1025.61 5.864	818.74 4.675	1251.44 7.155	1662.98 9.508	2007.43 11.478	20.32 0.0008	28.96 0.00114	30.99 0.00122

**EXTRA-LIGHT ISO 10 SERIES**  
**2MV/MM9100WI (7000C-...-P4/P4S)**  
**SPEED CAPABILITY DATA**

Fafnir Bearing Number	Timken ISO Bearing Number	Grease Capacity <sup>(1)</sup>				Operating Speeds <sup>(4)</sup> (DB Mounting) <sup>(5)</sup>					
		Low Speed <sup>(2)</sup>		High Speed <sup>(3)</sup>		Grease			Oil		
		25%	40%	10%	15%	DUL	DUM	DUH	DUL	DUM	DUH
		grams	grams	grams	grams	RPM	RPM	RPM	RPM	RPM	RPM
2MV/MM9100WICR	7000C-T-P4/P4S	0.20	0.40	0.10	0.20	54800	41100	27400	93200	69900	46600
2MV/MM9101WICR	7001C-T-P4/P4S	0.30	0.40	0.10	0.20	45800	34400	22900	77900	58500	38900
2MV/MM9102WICR	7002C-T-P4/P4S	0.30	0.50	0.15	0.20	38900	29200	19400	66100	49600	33000
2MV/MM9103WICR	7003C-T-P4/P4S	0.40	0.70	0.20	0.30	34500	25900	17200	58700	44000	29200
2MV/MM9104WICR	7004C-T-P4/P4S	0.70	1.20	0.35	0.50	29700	22300	14800	50500	37900	25200
2MV/MM9105WICR	7005C-T-P4/P4S	0.90	1.40	0.40	0.60	24700	18500	12400	42000	31500	21100
2MV/MM9106WICR	7006C-T-P4/P4S	1.30	2.00	0.55	0.80	20400	15300	10200	34700	26000	17300
2MV/MM9107WICR	7007C-T-P4/P4S	1.60	2.60	0.75	1.10	18100	13600	9000	30800	23100	15300
2MV/MM9108WICR	7008C-T-P4/P4S	2.00	3.20	0.90	1.40	15900	11900	8000	27000	20200	13600
2MV/MM9109WICR	7009C-T-P4/P4S	2.50	4.00	1.10	1.70	14300	10000	7200	24300	18200	12200
2MV/MM9110WICR	7010C-T-P4/P4S	2.80	4.40	1.25	1.90	13000	9800	6500	22100	16700	11100
2MV/MM9111WICR	7011C-T-P4/P4S	4.00	6.40	1.75	2.70	11800	8800	5900	20100	15000	10000
2MV/MM9112WICR	7012C-T-P4/P4S	4.20	6.80	1.90	2.80	10900	8200	5400	18500	13900	9200
2MV/MM9113WICR	7013C-T-P4/P4S	4.50	7.20	2.00	3.00	10200	7600	5100	17300	12900	8700
2MV/MM9114WICR	7014C-T-P4/P4S	6.30	10.00	2.80	4.20	9400	7000	4700	16000	11900	8000
2MV/MM9115WICR	7015C-T-P4/P4S	6.60	10.60	2.95	4.40	8800	6600	4400	15000	11200	7500
2MV/MM9116WICR	7016C-T-P4/P4S	8.60	13.80	3.85	5.80	8200	6200	4100	13900	10500	7000
2MV/MM9117WICR	7017C-T-P4/P4S	9.10	14.50	4.05	6.00	7800	5800	3900	13300	9900	6600
2MV/MM9118WICR	7018C-T-P4/P4S	11.70	18.80	5.20	7.80	7400	5500	3700	12600	9400	6300
2MV/MM9119WICR	7019C-T-P4/P4S	12.20	19.50	5.45	8.10	7000	5200	3500	11900	8800	6000
2MV/MM9120WICR	7020C-T-P4/P4S	12.10	19.40	5.40	8.10	6600	5000	3300	11200	8500	5600
2MV/MM9121WICR	7021C-T-P4/P4S	15.90	25.40	7.05	10.60	6300	4700	3200	10700	8000	5400
2MV/MM9122WICR	7022C-T-P4/P4S	18.90	30.20	8.40	12.60	6000	4500	3000	10200	7700	5100
2MV/MM9124WICR	7024C-T-P4/P4S	20.50	32.80	9.10	13.70	5500	4100	2800	9400	7000	4800
2MV/MM9126WICR	7026C-T-P4/P4S	31.70	50.70	14.10	21.10	5100	3800	2600	8700	6500	4400
2MV/MM9128WICR	7028C-T-P4/P4S	33.80	54.00	15.05	22.50	4700	3500	2400	8000	6000	4100
2MV/MM9130WICR	7030C-T-P4/P4S	41.10	65.70	18.25	27.40	4500	3400	2200	7700	5800	3700
2MV/MM9132WICR	7032C-T-P4/P4S	51.00	81.60	22.70	34.10	4200	3100	2100	7100	5300	3600
2MV/MM9134WICR	7034C-T-P4/P4S	66.30	106.00	29.50	44.20	3900	2900	2000	6600	4900	3400
2MV/MM9136WICR	7036C-T-P4/P4S	88.40	141.50	39.35	59.00	3700	2800	1800	6200	4700	3100
2MV/MM9140WICR	7040C-T-P4/P4S	121.00	193.50	53.80	80.70	3300	2500	1600	5600	4300	2700

<sup>(1)</sup>Fill weights based on specific gravity of 0.99.

<sup>(2)</sup>Low speed <500000 dN.

<sup>(3)</sup>High speed > 500000 dN.

<sup>(4)</sup>For ceramic ball complements, use 120 percent of speeds shown.

<sup>(5)</sup>For other mounting arrangement configurations, refer to the engineering section on permissible speed calculation methods.

**EXTRA-LIGHT ISO 10 SERIES**  
**3MV/MM9100WI (7000E-...-P4/P4S)**  
**SPEED CAPABILITY DATA**

Fafnir Bearing Number	Timken ISO Bearing Number	Grease Capacity <sup>(1)</sup>				Operating Speeds <sup>(4)</sup> (DB Mounting) <sup>(5)</sup>					
		Low Speed <sup>(2)</sup>		High Speed <sup>(3)</sup>		Grease			Oil		
		25%	40%	10%	15%	DUL	DUM	DUH	DUL	DUM	DUH
		grams	grams	grams	grams	RPM	RPM	RPM	RPM	RPM	RPM
3MV/MM9100WICR	7000E-T-P4/P4S	0.20	0.40	0.10	0.20	49320	36990	24660	83880	62910	41940
3MV/MM9101WICR	7001E-T-P4/P4S	0.30	0.40	0.10	0.20	41220	30960	20610	70110	52650	35010
3MV/MM9102WICR	7002E-T-P4/P4S	0.30	0.50	0.15	0.20	35010	26280	17460	59490	44640	29700
3MV/MM9103WICR	7003E-T-P4/P4S	0.40	0.70	0.20	0.30	31050	23310	15480	52830	39600	26280
3MV/MM9104WICR	7004E-T-P4/P4S	0.70	1.20	0.35	0.50	26730	20070	13320	45450	34110	22680
3MV/MM9105WICR	7005E-T-P4/P4S	0.90	1.40	0.40	0.60	22230	16650	11160	37800	28350	18990
3MV/MM9106WICR	7006E-T-P4/P4S	1.30	2.00	0.55	0.80	18360	13770	9180	31230	23400	15570
3MV/MM9107WICR	7007E-T-P4/P4S	1.60	2.60	0.75	1.10	16290	12240	8100	27720	20790	13770
3MV/MM9108WICR	7008E-T-P4/P4S	2.00	3.20	0.90	1.40	14310	10710	7200	24300	18180	12240
3MV/MM9109WICR	7009E-T-P4/P4S	2.50	4.00	1.10	1.70	12870	9000	6480	21870	16380	10980
3MV/MM9110WICR	7010E-T-P4/P4S	2.80	4.40	1.25	1.90	11700	8820	5850	19890	15030	9990
3MV/MM9111WICR	7011E-T-P4/P4S	4.00	6.40	1.75	2.70	10620	7920	5310	18090	13500	9000
3MV/MM9112WICR	7012E-T-P4/P4S	4.20	6.80	1.90	2.80	9810	7380	4860	16650	12510	8280
3MV/MM9113WICR	7013E-T-P4/P4S	4.50	7.20	2.00	3.00	9180	6840	4590	15570	11610	7830
3MV/MM9114WICR	7014E-T-P4/P4S	6.30	10.00	2.80	4.20	8460	6300	4230	14400	10710	7200
3MV/MM9115WICR	7015E-T-P4/P4S	6.60	10.60	2.95	4.40	7920	5940	3960	13500	10080	6750
3MV/MM9116WICR	7016E-T-P4/P4S	8.60	13.80	3.85	5.80	7380	5580	3690	12510	9450	6300
3MV/MM9117WICR	7017E-T-P4/P4S	9.10	14.50	4.05	6.00	7020	5220	3510	11970	8910	5940
3MV/MM9118WICR	7018E-T-P4/P4S	11.70	18.80	5.20	7.80	6660	4950	3330	11340	8460	5670
3MV/MM9119WICR	7019E-T-P4/P4S	12.20	19.50	5.45	8.10	6300	4680	3150	10710	7920	5400
3MV/MM9120WICR	7020E-T-P4/P4S	12.10	19.40	5.40	8.10	5940	4500	2970	10080	7650	5040
3MV/MM9121WICR	7021E-T-P4/P4S	15.90	25.40	7.05	10.60	5670	4230	2880	9630	7200	4860
3MV/MM9122WICR	7022E-T-P4/P4S	18.90	30.20	8.40	12.60	5400	4050	2700	9180	6930	4590
3MV/MM9124WICR	7024E-T-P4/P4S	20.50	32.80	9.10	13.70	4950	3690	2520	8460	6300	4320
3MV/MM9126WICR	7026E-T-P4/P4S	31.70	50.70	14.10	21.10	4590	3420	2340	7830	5850	3960
3MV/MM9128WICR	7028E-T-P4/P4S	33.80	54.00	15.05	22.50	4230	3150	2160	7200	5400	3690
3MV/MM9130WICR	7030E-T-P4/P4S	41.10	65.70	18.25	27.40	4050	3060	1980	6930	5220	3330
3MV/MM9132WICR	7032E-T-P4/P4S	51.00	81.60	22.70	34.10	3780	2790	1890	6390	4770	3240
3MV/MM9134WICR	7034E-T-P4/P4S	66.30	106.00	29.50	44.20	3510	2610	1800	5940	4410	3060
3MV/MM9136WICR	7036E-T-P4/P4S	88.40	141.50	39.35	59.00	3330	2520	1620	5580	4230	2790
3MV/MM9140WICR	7040E-T-P4/P4S	121.00	193.50	53.80	80.70	2970	2250	1440	5040	3870	2430

<sup>(1)</sup>Fill weights based on specific gravity of 0.99.

<sup>(2)</sup>Low speed <500000 dN.

<sup>(3)</sup>High speed > 500000 dN.

<sup>(4)</sup>For ceramic ball complements, use 120 percent of speeds shown.

<sup>(5)</sup>For other mounting arrangement configurations, refer to the engineering section on permissible speed calculation methods.

**EXTRA-LIGHT ISO 10 SERIES  
2(3)MMV9100HX (HX7000C(E)-...-P4S)**

**|SUPER PRECISION MMV**

Running accuracy and performance meet ABEC 9 (ISO P2) levels. Other features conform to ABEC 7 (ISO P4) requirements.

**WN CONSTRUCTION**

- Incorporates low shoulder on non-thrust side of both inner and outer rings.
- Balls separated by one-piece cage piloted against a ground thrust shoulder land of the outer ring.

**HIGH-SPEED SEAL OPTION**

Available with non-contact seals. Add VV suffix to part number (in place of CR cage designation). Ex: 2MMV9106HXVV SUL.

Bearing Number 15° C/2 <sup>(3)</sup> or 25° E/3 <sup>(4)</sup>	d Bore	D O.D.	C Width <sup>(1)</sup>	Ball Qty. x Dia.	Bearing Wt. kg lbs.	15° (C/2) Load Ratings						25° (E/3) Load Ratings					
						Steel Ball			Ceramic Ball			Steel Ball			Ceramic Ball		
						C <sub>0</sub> Static	C <sub>e</sub> Dynamic	Speed Rating <sup>(N<sub>g</sub>)</sup>	C <sub>0</sub> Static	C <sub>e</sub> Dynamic	Speed Rating <sup>(N<sub>g</sub>)</sup>	C <sub>0</sub> Static	C <sub>e</sub> Dynamic	Speed Rating <sup>(N<sub>g</sub>)</sup>	C <sub>0</sub> Static	C <sub>e</sub> Dynamic	Speed Rating <sup>(N<sub>g</sub>)</sup>
mm in.	mm in.	mm in.	mm in.	kg lbs.	N lbs.	N lbs.	RPM	N lbs.	N lbs.	RPM	N lbs.	N lbs.	RPM	N lbs.	N lbs.	RPM	
9100HX	<b>10</b>	<b>26</b>	<b>8</b>	<b>10 x 4.0</b>	<b>0.018</b>	<b>1180</b>	<b>3310</b>	<b>85800</b>	<b>1050</b>	<b>3310</b>	<b>102960</b>	<b>1140</b>	<b>3170</b>	<b>77200</b>	<b>1010</b>	<b>3170</b>	<b>92640</b>
HX7000	0.3937	1.0236	0.3150	10 x ½	0.04	270	740	85800	240	740	102960	260	710	77200	230	710	92640
9101HX	<b>12</b>	<b>28</b>	<b>8</b>	<b>11x4.0</b>	<b>0.021</b>	<b>1330</b>	<b>3560</b>	<b>75200</b>	<b>1200</b>	<b>3560</b>	<b>90240</b>	<b>1290</b>	<b>3380</b>	<b>67680</b>	<b>1160</b>	<b>3380</b>	<b>81216</b>
HX7001	0.4724	1.1024	0.3150	11x ½	0.046	300	800	75200	270	800	90240	290	760	67680	260	760	81216
9102HX	<b>15</b>	<b>32</b>	<b>9</b>	<b>12 x 4.8</b>	<b>0.027</b>	<b>2110</b>	<b>5210</b>	<b>64300</b>	<b>1880</b>	<b>5210</b>	<b>77160</b>	<b>2010</b>	<b>4980</b>	<b>57900</b>	<b>1790</b>	<b>4980</b>	<b>69480</b>
HX7002	0.5906	1.2598	0.3543	12 x ⅜	0.06	470	1170	64300	420	1170	77160	450	1120	57900	400	1120	69480
9103HX	<b>17</b>	<b>35</b>	<b>10</b>	<b>11x4.8</b>	<b>0.037</b>	<b>2000</b>	<b>4890</b>	<b>56800</b>	<b>1780</b>	<b>4890</b>	<b>68160</b>	<b>1910</b>	<b>4670</b>	<b>51120</b>	<b>1690</b>	<b>4670</b>	<b>61350</b>
HX7003	0.6693	1.378	0.3937	11x ⅜	0.082	450	1100	56800	400	1100	68160	430	1050	51120	380	1050	61350
9104HX	<b>20</b>	<b>42</b>	<b>12</b>	<b>12 x 6.4</b>	<b>0.064</b>	<b>3740</b>	<b>8730</b>	<b>48900</b>	<b>3330</b>	<b>8730</b>	<b>58680</b>	<b>3570</b>	<b>8370</b>	<b>44000</b>	<b>3180</b>	<b>8370</b>	<b>52800</b>
HX7004	0.7874	1.6535	0.4724	12 x ¼	0.14	840	1960	48900	750	1960	58680	800	1880	44000	710	1880	52800
9105HX	<b>25</b>	<b>47</b>	<b>12</b>	<b>13 x 6.4</b>	<b>0.073</b>	<b>4240</b>	<b>9190</b>	<b>40700</b>	<b>3770</b>	<b>9190</b>	<b>48840</b>	<b>4030</b>	<b>8760</b>	<b>36600</b>	<b>3590</b>	<b>8760</b>	<b>43920</b>
HX7005	0.9843	1.8504	0.4724	13 x ¼	0.16	950	2070	40700	850	2070	48840	910	1970	36600	810	1970	43920
9106HX	<b>30</b>	<b>55</b>	<b>13</b>	<b>14 x 7.1</b>	<b>0.104</b>	<b>5850</b>	<b>11900</b>	<b>33600</b>	<b>5210</b>	<b>11900</b>	<b>40320</b>	<b>5600</b>	<b>11300</b>	<b>30200</b>	<b>4990</b>	<b>11300</b>	<b>36240</b>
HX7006	1.1811	2.1654	0.5118	14 x ⅜	0.23	1320	2680	33600	1170	2680	40320	1260	2550	30200	1120	2550	36240
9107HX	<b>35</b>	<b>62</b>	<b>14</b>	<b>15 x 7.9</b>	<b>0.145</b>	<b>7770</b>	<b>15000</b>	<b>29800</b>	<b>6920</b>	<b>15000</b>	<b>35760</b>	<b>7430</b>	<b>14300</b>	<b>26800</b>	<b>6620</b>	<b>14300</b>	<b>32160</b>
HX7007	1.378	2.4409	0.5512	15 x ⅝	0.32	1750	3380	29800	1560	3380	35760	1670	3220	26800	1490	3220	32160
9108HX	<b>40</b>	<b>68</b>	<b>15</b>	<b>16 x 7.9</b>	<b>0.181</b>	<b>8510</b>	<b>15500</b>	<b>26200</b>	<b>7580</b>	<b>15500</b>	<b>31440</b>	<b>8090</b>	<b>14700</b>	<b>23600</b>	<b>7200</b>	<b>14700</b>	<b>28320</b>
HX7008	1.5748	2.6772	0.5906	16 x ⅝	0.40	1910	3490	26200	1700	3490	31440	1820	3310	23600	1620	3310	28320
9109HX	<b>45</b>	<b>75</b>	<b>16</b>	<b>17 x 8.7</b>	<b>0.224</b>	<b>10990</b>	<b>19170</b>	<b>23600</b>	<b>9740</b>	<b>19170</b>	<b>28320</b>	<b>10410</b>	<b>18190</b>	<b>21240</b>	<b>9250</b>	<b>18190</b>	<b>25500</b>
HX7009	1.7717	2.9528	0.6299	17 x ⅞	0.494	2470	4310	23600	2190	4310	28320	2340	4090	21240	2080	4090	25500
9110HX	<b>50</b>	<b>80</b>	<b>16</b>	<b>18 x 8.7</b>	<b>0.239</b>	<b>11790</b>	<b>19710</b>	<b>21500</b>	<b>10500</b>	<b>19710</b>	<b>25800</b>	<b>11250</b>	<b>18680</b>	<b>19350</b>	<b>10010</b>	<b>18680</b>	<b>23220</b>
HX7010	1.9685	3.1496	0.6299	18 x ⅞	0.528	2650	4430	21500	2360	4430	25800	2530	4200	19350	2250	4200	23220
9111HX	<b>55</b>	<b>90</b>	<b>18</b>	<b>24 x 7.9</b>	<b>0.399</b>	<b>13500</b>	<b>19400</b>	<b>18700</b>	<b>12000</b>	<b>19400</b>	<b>22440</b>	<b>12800</b>	<b>18300</b>	<b>16900</b>	<b>11400</b>	<b>18300</b>	<b>20280</b>
HX7011	2.1654	3.5433	0.7087	24 x ⅝	0.88	3030	4360	18700	2700	4360	22400	2880	4120	16900	2560	4120	20280
9112HX	<b>60</b>	<b>95</b>	<b>18</b>	<b>25 x 7.9</b>	<b>0.426</b>	<b>14200</b>	<b>19700</b>	<b>17400</b>	<b>12600</b>	<b>19700</b>	<b>20880</b>	<b>13400</b>	<b>18600</b>	<b>15700</b>	<b>11900</b>	<b>18600</b>	<b>18840</b>
HX7012	2.3622	3.7402	0.7087	25 x ⅝	0.94	3190	4420	17400	2840	4420	20880	3010	4180	15700	2680	4180	18840

<sup>(N<sub>g</sub>)</sup>For a single, grease-lubricated, spring-preloaded bearing. This value to be used in permissible operating speed (Sp) calculation.

<sup>(1)</sup>Width tolerance of preloaded bearing set +0.000/-0.254 mm (+0.0000/-0.0100 in.).

<sup>(2)</sup>Fill weights based upon specific gravity of 0.99.

<sup>(3)</sup>C is ISO designation for 15° contact angle, 2 is Timken designation for 15° contact angle.

<sup>(4)</sup>E is ISO designation for 25° contact angle, 3 is Timken designation for 25° contact angle.

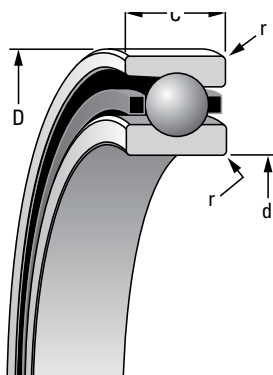

r Rad. <sup>(2)</sup>	Suggested Shoulder Diameters				Shaft Diameter		Mounting Fits		Fixed				Floating			
	Shaft		Housing						Housing Bore (Stationary)		Mounting Fits		Housing Bore (Stationary)		Mounting Fits	
	Max.	Min.	Max.	Min.	Max.	Min.	Loose	Tight	Max.	Min.	Tight	Loose	Max.	Min.	Loose	Loose
mm in.	mm in.	mm in.	mm in.	mm in.	mm in.	mm in.	mm in.	mm in.	mm in.	mm in.	mm in.	mm in.	mm in.	mm in.	mm in.	mm in.
<b>0.3</b> 0.012	<b>13.6</b> 0.54	<b>13.3</b> 0.53	<b>23.2</b> 0.92	<b>23</b> 0.91	<b>10.000</b> 0.39370	<b>9.995</b> 0.39350	<b>0.005</b> 0.00020	<b>0.004</b> 0.00015	<b>26.005</b> 1.02380	<b>26.000</b> 1.02360	<b>0.000</b> 0.00000	<b>0.010</b> 0.00040	<b>26.010</b> 1.02400	<b>26.005</b> 1.02380	<b>0.015</b> 0.00060	<b>0.005</b> 0.00020
<b>0.3</b> 0.012	<b>16.1</b> 0.64	<b>15.9</b> 0.63	<b>25.5</b> 1.01	<b>25.3</b> 1.00	<b>12.000</b> 0.47240	<b>11.995</b> 0.47220	<b>0.005</b> 0.00020	<b>0.004</b> 0.00015	<b>28.005</b> 1.10260	<b>28.000</b> 1.10240	<b>0.000</b> 0.00000	<b>0.010</b> 0.00040	<b>28.010</b> 1.10280	<b>28.005</b> 1.10260	<b>0.015</b> 0.00060	<b>0.005</b> 0.00020
<b>0.3</b> 0.012	<b>19.2</b> 0.76	<b>18.9</b> 0.75	<b>28.6</b> 1.13	<b>28.3</b> 1.12	<b>15.000</b> 0.59060	<b>14.995</b> 0.59040	<b>0.005</b> 0.00020	<b>0.004</b> 0.00015	<b>32.005</b> 1.26000	<b>32.000</b> 1.25980	<b>0.000</b> 0.00000	<b>0.011</b> 0.00045	<b>32.010</b> 1.26020	<b>32.005</b> 1.26000	<b>0.016</b> 0.00070	<b>0.005</b> 0.00020
<b>0.3</b> 0.012	<b>21.7</b> 0.86	<b>21.5</b> 0.85	<b>31.1</b> 1.23	<b>30.9</b> 1.22	<b>17.000</b> 0.66930	<b>16.995</b> 0.66910	<b>0.005</b> 0.00020	<b>0.004</b> 0.00015	<b>35.006</b> 1.37830	<b>35.000</b> 1.37800	<b>0.000</b> 0.00000	<b>0.012</b> 0.00050	<b>35.010</b> 1.37840	<b>35.005</b> 1.37820	<b>0.016</b> 0.00070	<b>0.005</b> 0.00020
<b>0.6</b> 0.024	<b>25.0</b> 0.99	<b>24.8</b> 0.98	<b>37.7</b> 1.49	<b>37.5</b> 1.48	<b>20.000</b> 0.78740	<b>19.995</b> 0.78720	<b>0.005</b> 0.00020	<b>0.005</b> 0.00020	<b>42.006</b> 1.65380	<b>42.000</b> 1.65350	<b>0.000</b> 0.00000	<b>0.012</b> 0.00050	<b>42.010</b> 1.65390	<b>42.005</b> 1.65370	<b>0.016</b> 0.00070	<b>0.005</b> 0.00020
<b>0.6</b> 0.024	<b>30.1</b> 1.19	<b>29.9</b> 1.18	<b>42.6</b> 1.68	<b>42.3</b> 1.67	<b>25.000</b> 0.98430	<b>24.995</b> 0.98410	<b>0.005</b> 0.00020	<b>0.005</b> 0.00020	<b>47.006</b> 1.85070	<b>47.000</b> 1.85040	<b>0.000</b> 0.00000	<b>0.012</b> 0.00050	<b>47.012</b> 1.85090	<b>47.007</b> 1.85070	<b>0.018</b> 0.00080	<b>0.007</b> 0.00030
<b>1.0</b> 0.039	<b>36.20</b> 1.43	<b>35.90</b> 1.42	<b>50.7</b> 2.00	<b>50.4</b> 1.99	<b>30.000</b> 1.18110	<b>29.995</b> 1.18090	<b>0.005</b> 0.00020	<b>0.005</b> 0.00020	<b>55.008</b> 2.16570	<b>55.000</b> 2.16540	<b>0.000</b> 0.00000	<b>0.015</b> 0.00060	<b>55.012</b> 2.16590	<b>55.007</b> 2.16570	<b>0.019</b> 0.00080	<b>0.007</b> 0.00030
<b>1.0</b> 0.039	<b>41.2</b> 1.62	<b>40.6</b> 1.60	<b>56.6</b> 2.23	<b>56.1</b> 2.21	<b>35.000</b> 1.37800	<b>34.995</b> 1.37780	<b>0.005</b> 0.00020	<b>0.006</b> 0.00025	<b>62.008</b> 2.44120	<b>62.000</b> 2.44090	<b>0.000</b> 0.00000	<b>0.015</b> 0.00060	<b>62.012</b> 2.44140	<b>62.007</b> 2.44120	<b>0.019</b> 0.00080	<b>0.007</b> 0.00030
<b>1.0</b> 0.039	<b>46.2</b> 1.82	<b>45.7</b> 1.80	<b>62.2</b> 2.45	<b>61.7</b> 2.43	<b>40.000</b> 1.57480	<b>39.995</b> 1.57460	<b>0.005</b> 0.00020	<b>0.006</b> 0.00025	<b>68.008</b> 2.67750	<b>68.000</b> 2.67720	<b>0.000</b> 0.00000	<b>0.015</b> 0.00060	<b>68.012</b> 2.67770	<b>68.007</b> 2.67750	<b>0.019</b> 0.00080	<b>0.007</b> 0.00030
<b>1.0</b> 0.039	<b>51.8</b> 2.04	<b>51.3</b> 2.02	<b>69.3</b> 2.73	<b>68.8</b> 2.71	<b>45.000</b> 1.7717	<b>44.995</b> 1.77150	<b>0.005</b> 0.00020	<b>0.006</b> 0.00025	<b>75.008</b> 2.95310	<b>75.000</b> 2.95280	<b>0.000</b> 0.00000	<b>0.015</b> 0.00060	<b>75.014</b> 2.95330	<b>75.009</b> 2.95310	<b>0.022</b> 0.00080	<b>0.009</b> 0.00030
<b>1.0</b> 0.039	<b>56.6</b> 2.23	<b>56.1</b> 2.21	<b>74.2</b> 2.92	<b>73.7</b> 2.90	<b>50.000</b> 1.96850	<b>49.995</b> 1.96830	<b>0.005</b> 0.00020	<b>0.006</b> 0.00025	<b>80.008</b> 3.14990	<b>80.000</b> 3.14960	<b>0.000</b> 0.00000	<b>0.015</b> 0.00060	<b>80.012</b> 3.15010	<b>80.008</b> 3.14990	<b>0.020</b> 0.00080	<b>0.008</b> 0.00030
<b>1.0</b> 0.039	<b>62.7</b> 2.47	<b>62.2</b> 2.45	<b>83.3</b> 3.28	<b>82.8</b> 3.26	<b>55.000</b> 2.16540	<b>54.995</b> 2.16520	<b>0.005</b> 0.00020	<b>0.007</b> 0.00030	<b>90.008</b> 3.54360	<b>90.000</b> 3.54330	<b>0.000</b> 0.00000	<b>0.016</b> 0.00060	<b>90.015</b> 3.54390	<b>90.007</b> 3.54360	<b>0.023</b> 0.00090	<b>0.007</b> 0.00030
<b>1.0</b> 0.039	<b>67.8</b> 2.67	<b>67.3</b> 2.65	<b>88.1</b> 3.47	<b>87.6</b> 3.45	<b>60.000</b> 2.36220	<b>59.995</b> 2.36200	<b>0.005</b> 0.00020	<b>0.007</b> 0.00030	<b>95.008</b> 3.74050	<b>95.000</b> 3.74020	<b>0.000</b> 0.00000	<b>0.016</b> 0.00060	<b>95.016</b> 3.74080	<b>95.009</b> 3.74050	<b>0.024</b> 0.00090	<b>0.009</b> 0.00030

*Continued on next page.*

**EXTRA-LIGHT ISO 10 SERIES — continued**  
**2(3)MMV9100HX (HX7000C(E)-...-P4S**  
**SUPER PRECISION MMV**

Running accuracy and performance meet ABEC 9 (ISO P2) levels. Other features conform to ABEC 7 (ISO P4) requirements.

**WN CONSTRUCTION**

- Incorporates low shoulder on non-thrust side of both inner and outer rings.
- Balls separated by one-piece cage piloted against a ground thrust shoulder land of the outer ring.

**HIGH-SPEED SEAL OPTION**

Available with non-contact seals. Add VV suffix to part number (in place of CR cage designation). Ex: 2MMV9106HXVV SUL.

Bearing Number 15° C/2 <sup>(3)</sup> or 25° E/3 <sup>(4)</sup>	d Bore	D O.D.	C Width <sup>(1)</sup>	Ball Qty. x Dia. mm in.	Bearing Wt. kg lbs.	15° (C/2) Load Ratings						25° (E/3) Load Ratings					
						Steel Ball			Ceramic Ball			Steel Ball			Ceramic Ball		
						C <sub>0</sub> Static	C <sub>e</sub> Dynamic	Speed Rating <sup>(N<sub>g</sub>)</sup>	C <sub>0</sub> Static	C <sub>e</sub> Dynamic	Speed Rating <sup>(N<sub>g</sub>)</sup>	C <sub>0</sub> Static	C <sub>e</sub> Dynamic	Speed Rating <sup>(N<sub>g</sub>)</sup>	C <sub>0</sub> Static	C <sub>e</sub> Dynamic	Speed Rating <sup>(N<sub>g</sub>)</sup>
mm in.	mm in.	mm in.	mm in.	kg lbs.	N lbs.	N lbs.	RPM	N lbs.	N lbs.	RPM	N lbs.	N lbs.	RPM	N lbs.	N lbs.	RPM	
9113HX	<b>65</b>	<b>100</b>	<b>18</b>	<b>25 x 8.7</b>	<b>0.445</b>	<b>17100</b>	<b>23500</b>	<b>16400</b>	<b>15200</b>	<b>23500</b>	<b>19680</b>	<b>16200</b>	<b>22200</b>	<b>14800</b>	<b>14400</b>	<b>22200</b>	<b>17760</b>
HX7013	2.5591	3.9370	0.7087	25 x 1/2	0.98	3850	5280	16400	3430	5280	19680	3640	4990	14800	3240	4990	17760
9114HX	<b>70</b>	<b>110</b>	<b>20</b>	<b>25 x 9.5</b>	<b>0.626</b>	<b>20400</b>	<b>27500</b>	<b>15000</b>	<b>18100</b>	<b>27500</b>	<b>18000</b>	<b>19200</b>	<b>85900</b>	<b>13500</b>	<b>17100</b>	<b>85900</b>	<b>16200</b>
HX7014	2.7559	4.3307	0.7874	25 x 3/8	1.38	4580	6180	15000	4080	6180	18000	4330	5830	13500	3850	5830	16200
9115HX	<b>75</b>	<b>115</b>	<b>20</b>	<b>26 x 9.5</b>	<b>0.658</b>	<b>21300</b>	<b>27900</b>	<b>14200</b>	<b>19000</b>	<b>27900</b>	<b>17040</b>	<b>20100</b>	<b>26408</b>	<b>12700</b>	<b>17900</b>	<b>26408</b>	<b>15240</b>
HX7015	2.9528	4.5276	0.7874	26 x 3/8	1.45	4790	6270	14200	4260	6270	17040	4520	5930	12700	4020	5930	15240
9116HX	<b>80</b>	<b>125</b>	<b>22</b>	<b>25 x 11.1</b>	<b>0.875</b>	<b>27600</b>	<b>36500</b>	<b>13200</b>	<b>24600</b>	<b>36500</b>	<b>15840</b>	<b>26200</b>	<b>34400</b>	<b>11900</b>	<b>23300</b>	<b>34400</b>	<b>14280</b>
HX7016	3.1496	4.9213	0.8661	25 x 7/16	1.93	6210	8210	13200	5530	8210	15840	5880	7740	11900	5240	7740	14280
9117HX	<b>85</b>	<b>130</b>	<b>22</b>	<b>26 x 11.1</b>	<b>0.916</b>	<b>29000</b>	<b>37100</b>	<b>12600</b>	<b>25800</b>	<b>37100</b>	<b>15120</b>	<b>27300</b>	<b>35000</b>	<b>11300</b>	<b>24300</b>	<b>35000</b>	<b>13560</b>
HX7017	3.3465	5.1181	0.8610	26 x 7/16	2.02	6510	8330	12600	5790	8330	15120	6140	7870	11300	5460	7870	13560
9118HX	<b>90</b>	<b>140</b>	<b>24</b>	<b>28 x 11.1</b>	<b>1.229</b>	<b>31300</b>	<b>38400</b>	<b>11700</b>	<b>27900</b>	<b>38400</b>	<b>14040</b>	<b>29400</b>	<b>36200</b>	<b>10500</b>	<b>26100</b>	<b>36200</b>	<b>12600</b>
HX7018	3.5433	5.5118	0.9449	28 x 7/16	2.71	7040	8630	11700	6260	8630	14040	6600	8150	10500	5880	8150	12600
9120HX	<b>100</b>	<b>150</b>	<b>24</b>	<b>27 x 12.7</b>	<b>1.288</b>	<b>39300</b>	<b>48200</b>	<b>10800</b>	<b>35000</b>	<b>48200</b>	<b>12960</b>	<b>37000</b>	<b>45500</b>	<b>9700</b>	<b>33000</b>	<b>45500</b>	<b>11640</b>
HX7020	3.9370	5.9055	0.9449	27 x 1/2	2.84	8840	10800	10800	7870	10800	12960	8330	10200	9700	7410	10200	11640
9122HX	<b>110</b>	<b>170</b>	<b>28</b>	<b>30 x 12.7</b>	<b>2.132</b>	<b>43800</b>	<b>50400</b>	<b>9500</b>	<b>38900</b>	<b>50400</b>	<b>11400</b>	<b>40800</b>	<b>47500</b>	<b>8560</b>	<b>36300</b>	<b>47500</b>	<b>10270</b>
HX7022	4.3307	6.6929	1.1024	30 x 1/2	4.70	9840	113000	9500	8760	113000	11400	9180	10700	8560	8170	10700	10270
9124HX	<b>120</b>	<b>180</b>	<b>28</b>	<b>29 x 14.3</b>	<b>2.218</b>	<b>53700</b>	<b>61700</b>	<b>8900</b>	<b>47800</b>	<b>61700</b>	<b>10680</b>	<b>50200</b>	<b>58100</b>	<b>8030</b>	<b>44700</b>	<b>58100</b>	<b>9640</b>
HX7024	4.7244	7.0866	1.1024	29 x 9/16	4.89	12100	139000	8900	10700	139000	10680	11300	13100	8030	10000	13100	9640

<sup>(N<sub>g</sub>)</sup>For a single, grease-lubricated, spring-preloaded bearing. This value to be used in permissible operating speed (Sp) calculation.

<sup>(1)</sup>Width tolerance of preloaded bearing set +0.000/-0.254 mm (+0.0000/-0.0100 in.).

<sup>(2)</sup>Fill weights based upon specific gravity of 0.99.

<sup>(3)</sup>C is ISO designation for 15° contact angle, 2 is Timken designation for 15° contact angle.

<sup>(4)</sup>E is ISO designation for 25° contact angle, 3 is Timken designation for 25° contact angle.



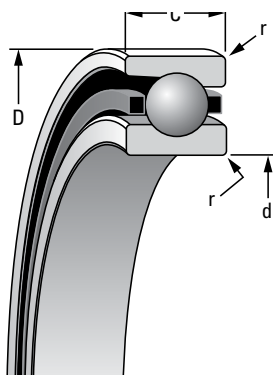

r Rad. <sup>(2)</sup>	Suggested Shoulder Diameters				Shaft Diameter		Mounting Fits		Fixed				Floating			
	Shaft		Housing						Housing Bore (Stationary)		Mounting Fits		Housing Bore (Stationary)		Mounting Fits	
	Max.	Min.	Max.	Min.	Max.	Min.	Loose	Tight	Max.	Min.	Tight	Loose	Max.	Min.	Loose	Loose
mm in.	mm in.	mm in.	mm in.	mm in.	mm in.	mm in.	mm in.	mm in.	mm in.	mm in.	mm in.	mm in.	mm in.	mm in.	mm in.	mm in.
<b>1.0</b> 0.039	<b>72.6</b> 2.86	<b>72.1</b> 2.84	<b>93.2</b> 3.67	<b>92.7</b> 3.65	<b>65.000</b> 2.55910	<b>64.995</b> 2.55890	<b>0.005</b> 0.00020	<b>0.007</b> 0.00030	<b>100.008</b> 3.93730	<b>100.000</b> 3.93700	<b>0.000</b> 0.00000	<b>0.016</b> 0.00060	<b>100.018</b> 3.93770	<b>100.010</b> 3.93740	<b>0.025</b> 0.00100	<b>0.010</b> 0.00040
<b>1.0</b> 0.039	<b>78.2</b> 3.08	<b>77.7</b> 3.06	<b>102.4</b> 4.03	<b>101.9</b> 4.01	<b>70.000</b> 2.75590	<b>69.995</b> 2.75570	<b>0.005</b> 0.00020	<b>0.007</b> 0.00030	<b>110.008</b> 4.33100	<b>110.000</b> 4.33070	<b>0.000</b> 0.00000	<b>0.016</b> 0.00060	<b>110.018</b> 4.33140	<b>110.010</b> 4.33110	<b>0.025</b> 0.00100	<b>0.010</b> 0.00040
<b>1.0</b> 0.039	<b>83.4</b> 3.29	<b>82.7</b> 3.26	<b>107.3</b> 4.23	<b>106.6</b> 4.20	<b>75.005</b> 2.95300	<b>74.995</b> 2.95260	<b>0.005</b> 0.00020	<b>0.012</b> 0.00050	<b>115.008</b> 4.52790	<b>115.000</b> 4.52760	<b>0.000</b> 0.00000	<b>0.016</b> 0.00060	<b>115.019</b> 4.52830	<b>115.011</b> 4.52800	<b>0.026</b> 0.00100	<b>0.010</b> 0.00040
<b>1.0</b> 0.039	<b>89.3</b> 3.52	<b>88.5</b> 3.49	<b>116.5</b> 4.59	<b>115.7</b> 4.56	<b>80.005</b> 3.14980	<b>79.995</b> 3.14940	<b>0.005</b> 0.00020	<b>0.012</b> 0.00050	<b>125.008</b> 4.92160	<b>125.000</b> 4.92130	<b>0.000</b> 0.00000	<b>0.017</b> 0.00070	<b>125.021</b> 4.92210	<b>125.011</b> 4.92170	<b>0.030</b> 0.00120	<b>0.011</b> 0.00040
<b>1.0</b> 0.039	<b>94.9</b> 3.74	<b>94.1</b> 3.71	<b>122.1</b> 4.81	<b>121.3</b> 4.78	<b>85.005</b> 3.34670	<b>84.995</b> 3.34630	<b>0.005</b> 0.00020	<b>0.012</b> 0.00050	<b>130.009</b> 5.11850	<b>130.000</b> 5.11810	<b>0.000</b> 0.00000	<b>0.018</b> 0.00070	<b>130.020</b> 5.11890	<b>130.010</b> 5.11850	<b>0.029</b> 0.00110	<b>0.010</b> 0.00040
<b>1.5</b> 0.059	<b>100.5</b> 3.96	<b>99.7</b> 3.93	<b>130.9</b> 5.16	<b>130.2</b> 5.13	<b>90.005</b> 3.54350	<b>89.995</b> 3.54310	<b>0.005</b> 0.00020	<b>0.013</b> 0.00050	<b>140.009</b> 5.51220	<b>140.000</b> 5.51180	<b>0.000</b> 0.00000	<b>0.018</b> 0.00070	<b>140.020</b> 5.51260	<b>140.010</b> 5.51220	<b>0.029</b> 0.00110	<b>0.010</b> 0.00040
<b>1.5</b> 0.059	<b>110.6</b> 4.36	<b>109.9</b> 4.33	<b>140.8</b> 5.55	<b>140.1</b> 5.52	<b>100.005</b> 3.93720	<b>99.995</b> 3.93680	<b>0.005</b> 0.00020	<b>0.013</b> 0.00050	<b>150.009</b> 5.90590	<b>150.000</b> 5.90550	<b>0.000</b> 0.00000	<b>0.018</b> 0.00070	<b>150.023</b> 5.90640	<b>150.012</b> 5.90600	<b>0.032</b> 0.00120	<b>0.012</b> 0.00050
<b>2.0</b> 0.079	<b>123.1</b> 4.85	<b>122.3</b> 4.82	<b>158.4</b> 6.24	<b>157.6</b> 6.21	<b>110.005</b> 4.33090	<b>109.995</b> 4.33050	<b>0.005</b> 0.00020	<b>0.013</b> 0.00050	<b>170.010</b> 6.69330	<b>170.000</b> 6.69290	<b>0.000</b> 0.00000	<b>0.020</b> 0.00080	<b>170.022</b> 6.69380	<b>170.012</b> 6.69340	<b>0.032</b> 0.00130	<b>0.012</b> 0.00050
<b>2.0</b> 0.079	<b>133.2</b> 5.25	<b>132.5</b> 5.22	<b>168.3</b> 6.63	<b>167.5</b> 6.60	<b>120.005</b> 4.72460	<b>119.995</b> 4.72420	<b>0.005</b> 0.00020	<b>0.013</b> 0.00050	<b>180.010</b> 7.08700	<b>180.000</b> 7.08660	<b>0.000</b> 0.00000	<b>0.020</b> 0.00080	<b>180.022</b> 7.08750	<b>180.012</b> 7.08710	<b>0.032</b> 0.00130	<b>0.012</b> 0.00050

**EXTRA-LIGHT ISO 10 SERIES**  
**2MMV9100HX (HX7000C-...-P4S)**  
**DUPLEX PERFORMANCE DATA**

Bearing Number	Preload				Axial Stiffness <sup>(1)</sup>				Radial Stiffness <sup>(1)</sup>				Spacer Offsets <sup>(1)</sup>		
	DUX X-light	DUL Light	DUM Med.	DUH Heavy	X-light	Light	Med.	Heavy	X-light	Light	Med.	Heavy	X-light to Light	Light to Med.	Med. to Heavy
	N lbs.	N lbs.	N lbs.	N lbs.	N/μm 10 <sup>6</sup> lbs./in.	N/μm 10 <sup>6</sup> lbs./in.	N/μm 10 <sup>6</sup> lbs./in.	N/μm 10 <sup>6</sup> lbs./in.	N/μm 10 <sup>6</sup> lbs./in.	N/μm 10 <sup>6</sup> lbs./in.	N/μm 10 <sup>6</sup> lbs./in.	N/μm 10 <sup>6</sup> lbs./in.	μm in.	μm in.	μm in.
2MMV9100HXCR	—	<b>20</b>	<b>70</b>	<b>130</b>	—	<b>15.04</b>	<b>23.52</b>	<b>32.08</b>	—	<b>82.03</b>	<b>117.94</b>	<b>147.16</b>	—	<b>9.60</b>	<b>10.16</b>
HX7000C-T-P4S	—	5	15	30	—	0.086	0.135	0.183	—	0.469	0.674	0.841	—	0.00038	0.00040
2MMV9101HXCR	—	<b>20</b>	<b>70</b>	<b>130</b>	—	<b>14.41</b>	<b>22.56</b>	<b>30.78</b>	—	<b>86.12</b>	<b>124.07</b>	<b>154.96</b>	—	<b>9.60</b>	<b>10.16</b>
HX7001C-T-P4S	—	5	15	30	—	0.082	0.129	0.176	—	0.492	0.709	0.886	—	0.00038	0.00040
2MMV9102HXCR	—	<b>20</b>	<b>70</b>	<b>130</b>	—	<b>16.14</b>	<b>25.08</b>	<b>33.98</b>	—	<b>97.10</b>	<b>140.43</b>	<b>175.63</b>	—	<b>8.64</b>	<b>9.15</b>
HX7002C-T-P4S	—	5	15	30	—	0.092	0.143	0.194	—	0.555	0.803	1.004	—	0.00034	0.00036
2MMV9103HXCR	—	<b>20</b>	<b>70</b>	<b>130</b>	—	<b>16.76</b>	<b>25.73</b>	<b>34.53</b>	—	<b>101.49</b>	<b>148.00</b>	<b>185.57</b>	—	<b>8.13</b>	<b>8.64</b>
HX7003C-T-P4S	—	5	15	30	—	0.096	0.147	0.197	—	0.580	0.846	1.061	—	0.00032	0.00034
2MMV9104HXCR	<b>20</b>	<b>40</b>	<b>133</b>	<b>270</b>	<b>17.37</b>	<b>22.51</b>	<b>35.15</b>	<b>47.84</b>	<b>105.04</b>	<b>134.87</b>	<b>194.56</b>	<b>243.11</b>	<b>4.57</b>	<b>12.28</b>	<b>12.90</b>
HX7004C-T-P4S	5	10	30	60	0.099	0.129	0.201	0.274	0.600	0.771	1.112	1.390	0.00018	0.00048	0.00051
2MMV9105HXCR	<b>20</b>	<b>40</b>	<b>130</b>	<b>270</b>	<b>18.28</b>	<b>24.47</b>	<b>37.67</b>	<b>50.65</b>	<b>110.25</b>	<b>148.16</b>	<b>215.62</b>	<b>270.22</b>	<b>4.06</b>	<b>11.68</b>	<b>12.19</b>
HX7005C-T-P4S	5	10	30	60	0.104	0.140	0.215	0.290	0.630	0.847	1.233	1.545	0.00016	0.00046	0.00048
2MMV9106HXCR	<b>40</b>	<b>70</b>	<b>200</b>	<b>400</b>	<b>25.54</b>	<b>29.12</b>	<b>45.23</b>	<b>61.28</b>	<b>154.58</b>	<b>175.20</b>	<b>253.36</b>	<b>316.90</b>	<b>3.21</b>	<b>14.22</b>	<b>14.99</b>
HX7006C-T-P4S	10	15	45	90	0.146	0.167	0.259	0.350	0.883	1.002	1.449	1.812	0.00013	0.00056	0.00059
2MMV9107HXCR	<b>40</b>	<b>70</b>	<b>200</b>	<b>400</b>	<b>27.40</b>	<b>31.83</b>	<b>49.16</b>	<b>66.32</b>	<b>165.77</b>	<b>192.30</b>	<b>279.07</b>	<b>349.45</b>	<b>3.00</b>	<b>13.21</b>	<b>13.97</b>
HX7007C-T-P4S	10	15	45	90	0.156	0.182	0.281	0.379	0.947	1.100	1.596	1.998	0.00012	0.00052	0.00055
2MMV9108HXCR	<b>40</b>	<b>70</b>	<b>200</b>	<b>400</b>	<b>28.55</b>	<b>33.14</b>	<b>51.07</b>	<b>68.74</b>	<b>172.41</b>	<b>200.51</b>	<b>291.49</b>	<b>365.23</b>	<b>2.88</b>	<b>14.22</b>	<b>13.21</b>
HX7008C-T-P4S	10	15	45	90	0.163	0.190	0.292	0.393	0.985	1.146	1.667	2.088	0.00011	0.00056	0.00052
2MMV9109HXCR	<b>40</b>	<b>90</b>	<b>270</b>	<b>530</b>	<b>28.79</b>	<b>37.11</b>	<b>57.16</b>	<b>76.89</b>	<b>170.49</b>	<b>224.52</b>	<b>326.52</b>	<b>409.16</b>	<b>5.33</b>	<b>14.99</b>	<b>16.00</b>
HX7009C-T-P4S	10	20	60	120	0.164	0.212	0.327	0.440	0.974	1.284	1.867	2.339	0.00021	0.00059	0.00063
2MMV9110HXCR	<b>40</b>	<b>90</b>	<b>270</b>	<b>530</b>	<b>30.00</b>	<b>38.64</b>	<b>59.38</b>	<b>79.72</b>	<b>176.71</b>	<b>234.02</b>	<b>341.02</b>	<b>427.54</b>	<b>5.08</b>	<b>14.22</b>	<b>15.24</b>
HX7010C-T-P4S	10	20	60	120	0.171	0.221	0.340	0.456	1.009	1.338	1.950	2.445	0.00020	0.00056	0.00060
2MMV9111HXCR	<b>75</b>	<b>110</b>	<b>330</b>	<b>670</b>	<b>42.85</b>	<b>51.77</b>	<b>80.07</b>	<b>108.14</b>	<b>258.75</b>	<b>312.41</b>	<b>452.90</b>	<b>566.97</b>	<b>3.75</b>	<b>13.46</b>	<b>14.22</b>
HX7011C-T-P4S	15	25	75	150	0.245	0.296	0.458	0.618	1.478	1.786	2.590	3.242	0.00015	0.00053	0.00056

<sup>(1)</sup>For DB or DF arrangements only. For other mounting arrangements, contact your Timken representative.

**MOUNTING ARRANGEMENTS**

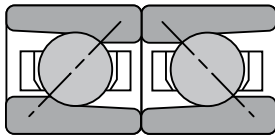

**Back-to-Back  
DB**

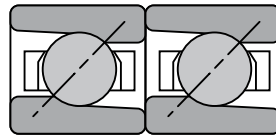

**Tandem  
DT**

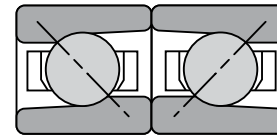

**Face-to-Face  
DF**

Bearing Number	Preload				Axial Stiffness <sup>(1)</sup>				Radial Stiffness <sup>(1)</sup>				Spacer Offsets <sup>(1)</sup>		
	DUX X-light	DUL Light	DUM Med.	DUH Heavy	X-light	Light	Med.	Heavy	X-light	Light	Med.	Heavy	X-light to Light	Light to Med.	Med. to Heavy
	N lbs.	N lbs.	N lbs.	N lbs.	N/μm 10 <sup>6</sup> lbs./in.	N/μm 10 <sup>6</sup> lbs./in.	N/μm 10 <sup>6</sup> lbs./in.	N/μm 10 <sup>6</sup> lbs./in.	N/μm 10 <sup>6</sup> lbs./in.	N/μm 10 <sup>6</sup> lbs./in.	N/μm 10 <sup>6</sup> lbs./in.	N/μm 10 <sup>6</sup> lbs./in.	μm in.	μm in.	μm in.
2MMV9112HXCR	<b>75</b>	<b>110</b>	<b>330</b>	<b>670</b>	<b>43.97</b>	<b>53.10</b>	<b>82.01</b>	<b>110.61</b>	<b>265.08</b>	<b>320.78</b>	<b>465.55</b>	<b>582.98</b>	<b>3.66</b>	<b>13.21</b>	<b>13.97</b>
HX7012C-T-P4S	15	25	75	150	0.251	0.304	0.469	0.632	1.514	1.834	2.662	3.333	0.00014	0.00052	0.00055
2MMV9113HXCR	<b>75</b>	<b>130</b>	<b>400</b>	<b>800</b>	<b>45.12</b>	<b>58.22</b>	<b>89.90</b>	<b>121.21</b>	<b>268.46</b>	<b>351.81</b>	<b>510.67</b>	<b>639.54</b>	<b>5.08</b>	<b>14.22</b>	<b>15.24</b>
HX7013C-T-P4S	15	30	90	180	0.258	0.333	0.514	0.693	1.533	2.012	2.920	3.657	0.00020	0.00056	0.00060
2MMV9114HXCR	<b>90</b>	<b>160</b>	<b>470</b>	<b>930</b>	<b>51.30</b>	<b>63.03</b>	<b>97.26</b>	<b>131.05</b>	<b>307.82</b>	<b>381.09</b>	<b>553.47</b>	<b>693.25</b>	<b>4.66</b>	<b>15.49</b>	<b>16.26</b>
HX7014C-T-P4S	20	35	105	210	0.293	0.360	0.556	0.749	1.758	2.179	3.165	3.964	0.00018	0.00061	0.00064
2MMV9115HXCR	<b>90</b>	<b>160</b>	<b>470</b>	<b>930</b>	<b>52.60</b>	<b>64.61</b>	<b>99.54</b>	<b>133.94</b>	<b>314.73</b>	<b>390.85</b>	<b>568.27</b>	<b>712.02</b>	<b>4.54</b>	<b>14.99</b>	<b>16.00</b>
HX7015C-T-P4S	20	35	105	210	0.300	0.369	0.569	0.766	1.797	2.235	3.249	4.071	0.00018	0.00059	0.00063
2MMV9116HXCR	<b>110</b>	<b>200</b>	<b>600</b>	<b>1200</b>	<b>56.45</b>	<b>70.15</b>	<b>108.30</b>	<b>146.02</b>	<b>349.49</b>	<b>439.38</b>	<b>638.84</b>	<b>800.38</b>	<b>5.61</b>	<b>17.78</b>	<b>18.80</b>
HX7016C-T-P4S	25	45	135	270	0.322	0.401	0.619	0.835	1.996	2.512	3.653	4.576	0.00022	0.00070	0.00074
2MMV9117HXCR	<b>110</b>	<b>220</b>	<b>670</b>	<b>1330</b>	<b>59.49</b>	<b>76.75</b>	<b>118.46</b>	<b>159.68</b>	<b>353.68</b>	<b>463.90</b>	<b>673.59</b>	<b>843.65</b>	<b>6.60</b>	<b>18.03</b>	<b>19.05</b>
HX7017C-T-P4S	25	50	150	300	0.340	0.439	0.677	0.913	2.020	2.652	3.851	4.824	0.00026	0.00071	0.00075
2MMV9118HXCR	<b>110</b>	<b>220</b>	<b>670</b>	<b>1330</b>	<b>62.38</b>	<b>80.38</b>	<b>123.74</b>	<b>166.38</b>	<b>368.73</b>	<b>486.55</b>	<b>707.98</b>	<b>887.25</b>	<b>6.35</b>	<b>17.27</b>	<b>18.29</b>
HX7018C-T-P4S	25	50	150	300	0.356	0.460	0.708	0.951	2.106	2.782	4.048	5.073	0.00025	0.00068	0.00072
2MMV9120HXCR	<b>130</b>	<b>270</b>	<b>800</b>	<b>1600</b>	<b>67.55</b>	<b>87.00</b>	<b>133.68</b>	<b>179.46</b>	<b>397.75</b>	<b>526.89</b>	<b>767.79</b>	<b>962.61</b>	<b>6.86</b>	<b>19.30</b>	<b>20.32</b>
HX7020C-T-P4S	30	60	180	360	0.386	0.497	0.764	1.026	2.271	3.013	4.390	5.504	0.00027	0.00076	0.00080
2MMV9122HXCR	<b>160</b>	<b>290</b>	<b>870</b>	<b>1730</b>	<b>76.40</b>	<b>95.76</b>	<b>147.00</b>	<b>197.22</b>	<b>451.65</b>	<b>580.13</b>	<b>846.11</b>	<b>1061.03</b>	<b>6.86</b>	<b>19.05</b>	<b>20.07</b>
HX7022C-T-P4S	35	65	195	390	0.436	0.548	0.841	1.128	2.579	3.317	4.838	6.067	0.00027	0.00075	0.00079
2MMV9124HXCR	<b>180</b>	<b>360</b>	<b>1070</b>	<b>2140</b>	<b>79.34</b>	<b>108.67</b>	<b>166.21</b>	<b>222.25</b>	<b>480.39</b>	<b>623.59</b>	<b>910.14</b>	<b>1141.66</b>	<b>7.37</b>	<b>20.57</b>	<b>21.84</b>
HX7024C-T-P4S	40	80	240	480	0.453	0.621	0.950	1.271	2.743	3.565	5.204	6.528	0.00029	0.00081	0.00086

**EXTRA-LIGHT ISO 10 SERIES  
3MMV9100HX (HX7000E-...-P4S)  
DUPLEX PERFORMANCE DATA**

Bearing Number	Preload				Axial Stiffness <sup>(1)</sup>				Radial Stiffness <sup>(1)</sup>				Spacer Offsets <sup>(1)</sup>		
	DUX X-light	DUL Light	DUM Med.	DUH Heavy	X-light	Light	Med.	Heavy	X-light	Light	Med.	Heavy	X-light to Light	Light to Med.	Med. to Heavy
	<b>N</b> lbs.	<b>N</b> lbs.	<b>N</b> lbs.	<b>N</b> lbs.	<b>N/μm</b> 10 <sup>6</sup> lbs./in.	<b>N/μm</b> 10 <sup>6</sup> lbs./in.	<b>N/μm</b> 10 <sup>6</sup> lbs./in.	<b>N/μm</b> 10 <sup>6</sup> lbs./in.	<b>N/μm</b> 10 <sup>6</sup> lbs./in.	<b>N/μm</b> 10 <sup>6</sup> lbs./in.	<b>N/μm</b> 10 <sup>6</sup> lbs./in.	<b>N/μm</b> 10 <sup>6</sup> lbs./in.	<b>N/μm</b> 10 <sup>6</sup> lbs./in.	<b>μm</b> in.	<b>μm</b> in.
3MMV9100HXCR	<b>20</b>	<b>45</b>	<b>135</b>	<b>265</b>	<b>28.53</b>	<b>36.54</b>	<b>55.09</b>	<b>72.65</b>	<b>60.85</b>	<b>76.89</b>	<b>110.03</b>	<b>137.02</b>	<b>2.54</b>	<b>7.62</b>	<b>8.13</b>
HX7000E-T-P4S	5	10	30	60	0.163	0.209	0.315	0.415	0.348	0.440	0.629	0.783	0.00010	0.00030	0.00032
3MMV9101HXCR	<b>20</b>	<b>45</b>	<b>135</b>	<b>265</b>	<b>29.84</b>	<b>38.09</b>	<b>56.98</b>	<b>74.58</b>	<b>64.50</b>	<b>82.01</b>	<b>117.87</b>	<b>147.20</b>	<b>2.54</b>	<b>7.62</b>	<b>8.13</b>
HX7001E-T-P4S	5	10	30	60	0.171	0.218	0.326	0.426	0.369	0.469	0.674	0.842	0.00010	0.00030	0.00032
3MMV9102HXCR	<b>20</b>	<b>45</b>	<b>135</b>	<b>265</b>	<b>33.62</b>	<b>42.87</b>	<b>63.87</b>	<b>83.30</b>	<b>72.48</b>	<b>92.56</b>	<b>133.40</b>	<b>166.80</b>	<b>2.54</b>	<b>6.60</b>	<b>7.11</b>
HX7002E-T-P4S	5	10	30	60	0.192	0.245	0.365	0.476	0.414	0.529	0.763	0.954	0.00010	0.00026	0.00028
3MMV9103HXCR	<b>20</b>	<b>45</b>	<b>135</b>	<b>265</b>	<b>35.01</b>	<b>44.56</b>	<b>66.06</b>	<b>85.70</b>	<b>75.19</b>	<b>97.38</b>	<b>141.07</b>	<b>176.82</b>	<b>2.03</b>	<b>6.60</b>	<b>7.11</b>
HX7003E-T-P4S	5	10	30	60	0.200	0.255	0.378	0.490	0.430	0.557	0.807	1.011	0.00008	0.00026	0.00028
3MMV9104HXCR	<b>45</b>	<b>90</b>	<b>265</b>	<b>535</b>	<b>46.14</b>	<b>58.91</b>	<b>88.06</b>	<b>115.19</b>	<b>101.49</b>	<b>129.20</b>	<b>185.92</b>	<b>232.09</b>	<b>3.56</b>	<b>9.65</b>	<b>10.67</b>
HX7004E-T-P4S	10	20	60	120	0.264	0.337	0.504	0.659	0.580	0.739	1.063	1.327	0.00014	0.00038	0.00042
3MMV9105HXCR	<b>45</b>	<b>90</b>	<b>265</b>	<b>535</b>	<b>49.51</b>	<b>63.14</b>	<b>94.13</b>	<b>122.81</b>	<b>105.90</b>	<b>135.11</b>	<b>194.66</b>	<b>243.29</b>	<b>3.05</b>	<b>9.14</b>	<b>9.65</b>
HX7005E-T-P4S	10	20	60	120	0.283	0.361	0.538	0.702	0.606	0.773	1.113	1.391	0.00012	0.00036	0.00038
3MMV9106HXCR	<b>65</b>	<b>135</b>	<b>400</b>	<b>800</b>	<b>60.38</b>	<b>76.97</b>	<b>114.73</b>	<b>149.66</b>	<b>131.07</b>	<b>167.38</b>	<b>241.19</b>	<b>301.70</b>	<b>4.06</b>	<b>11.18</b>	<b>12.19</b>
HX7006E-T-P4S	15	30	90	180	0.345	0.440	0.656	0.856	0.749	0.957	1.379	1.725	0.00016	0.00044	0.00048
3MMV9107HXCR	<b>65</b>	<b>135</b>	<b>400</b>	<b>800</b>	<b>66.30</b>	<b>84.46</b>	<b>125.56</b>	<b>163.34</b>	<b>143.33</b>	<b>183.99</b>	<b>265.67</b>	<b>332.66</b>	<b>3.56</b>	<b>10.16</b>	<b>11.18</b>
HX7007E-T-P4S	15	30	90	180	0.379	0.483	0.718	0.934	0.820	1.052	1.519	1.902	0.00014	0.00040	0.00044
3MMV9108HXCR	<b>65</b>	<b>135</b>	<b>400</b>	<b>800</b>	<b>69.19</b>	<b>88.08</b>	<b>130.79</b>	<b>169.95</b>	<b>149.12</b>	<b>191.87</b>	<b>277.57</b>	<b>347.53</b>	<b>3.56</b>	<b>9.65</b>	<b>10.67</b>
HX7008E-T-P4S	15	30	90	180	0.396	0.504	0.748	0.972	0.853	1.097	1.587	1.987	0.00014	0.00038	0.00042
3MMV9109HXCR	<b>90</b>	<b>175</b>	<b>535</b>	<b>1065</b>	<b>76.94</b>	<b>97.94</b>	<b>145.46</b>	<b>189.07</b>	<b>167.50</b>	<b>215.65</b>	<b>312.02</b>	<b>390.73</b>	<b>4.06</b>	<b>11.68</b>	<b>12.70</b>
HX7009E-T-P4S	20	40	120	240	0.440	0.560	0.832	1.081	0.958	1.233	1.784	2.234	0.00016	0.00046	0.00050
3MMV9110HXCR	<b>90</b>	<b>175</b>	<b>535</b>	<b>1065</b>	<b>80.28</b>	<b>102.16</b>	<b>151.53</b>	<b>196.76</b>	<b>174.06</b>	<b>225.10</b>	<b>325.84</b>	<b>408.22</b>	<b>4.06</b>	<b>11.18</b>	<b>12.19</b>
HX7010E-T-P4S	20	40	120	240	0.459	0.584	0.866	1.125	0.995	1.287	1.863	2.334	0.00016	0.00044	0.00048
3MMV9111HXCR	<b>110</b>	<b>225</b>	<b>665</b>	<b>1335</b>	<b>107.69</b>	<b>137.19</b>	<b>204.11</b>	<b>265.67</b>	<b>233.14</b>	<b>298.73</b>	<b>431.13</b>	<b>539.57</b>	<b>3.56</b>	<b>10.16</b>	<b>11.18</b>
HX7011E-T-P4S	25	50	150	300	0.616	0.784	1.167	1.519	1.333	1.708	2.465	3.085	0.00014	0.00040	0.00044

<sup>(1)</sup>For DB or DF arrangements only. For other mounting arrangements, contact your Timken representative.

**MOUNTING ARRANGEMENTS**

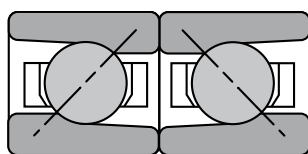

**Back-to-Back  
DB**

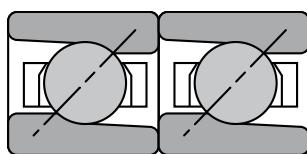

**Tandem  
DT**

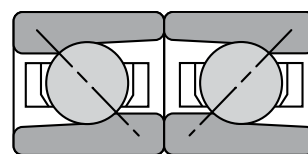

**Face-to-Face  
DF**

Bearing Number	Preload				Axial Stiffness <sup>(1)</sup>				Radial Stiffness <sup>(1)</sup>				Spacer Offsets <sup>(1)</sup>		
	DUX X-light	DUL Light	DUM Med.	DUH Heavy	X-light	Light	Med.	Heavy	X-light	Light	Med.	Heavy	X-light to Light	Light to Med.	Med. to Heavy
	N lbs.	N lbs.	N lbs.	N lbs.	N/μm 10 <sup>6</sup> lbs./in.	N/μm 10 <sup>6</sup> lbs./in.	N/μm 10 <sup>6</sup> lbs./in.	N/μm 10 <sup>6</sup> lbs./in.	N/μm 10 <sup>6</sup> lbs./in.	N/μm 10 <sup>6</sup> lbs./in.	N/μm 10 <sup>6</sup> lbs./in.	N/μm 10 <sup>6</sup> lbs./in.	μm in.	μm in.	μm in.
3MMV9112HXCR	110	225	665	1335	110.61	140.88	209.36	272.49	239.09	306.77	443.20	554.78	3.56	10.16	11.18
HX7012E-T-P4S	25	50	150	300	0.632	0.806	1.197	1.558	1.367	1.754	2.534	3.172	0.00014	0.00040	0.00044
3MMV9113HXCR	135	265	800	1600	120.89	153.96	228.94	297.68	262.52	337.21	487.10	609.70	4.06	11.18	12.19
HX7013E-T-P4S	30	60	180	360	0.691	0.880	1.309	1.702	1.501	1.928	2.785	3.486	0.00016	0.00044	0.00048
3MMV9114HXCR	155	310	935	1870	132.07	168.17	249.76	324.79	282.99	363.79	525.75	658.32	4.06	11.68	13.21
HX7014E-T-P4S	35	70	210	420	0.755	0.962	1.428	1.857	1.618	2.080	3.006	3.764	0.00016	0.00046	0.00052
3MMV9115HXCR	155	310	935	1870	133.90	170.48	253.26	329.16	291.73	375.51	542.89	679.84	4.06	11.68	12.70
HX7015E-T-P4S	35	70	210	420	0.766	0.975	1.448	1.882	1.668	2.147	3.104	3.887	0.00016	0.00046	0.00050
3MMV9116HXCR	200	400	1200	2400	150.08	190.99	283.69	368.34	323.91	417.49	603.93	756.44	4.57	13.21	14.73
HX7016E-T-P4S	45	90	270	540	0.858	1.092	1.622	2.106	1.852	2.387	3.453	4.325	0.00018	0.00052	0.00058
3MMV9117HXCR	225	445	1335	2670	159.70	203.41	302.23	393.18	345.78	444.25	641.88	803.49	5.08	13.72	15.24
HX7017E-T-P4S	50	100	300	600	0.913	1.163	1.728	2.248	1.977	2.540	3.670	4.594	0.00020	0.00054	0.00060
3MMV9118HXCR	225	445	1335	2670	167.66	213.38	316.74	411.36	361.69	466.28	674.76	845.12	4.57	13.21	14.73
HX7018E-T-P4S	50	100	300	600	0.959	1.220	1.811	2.352	2.068	2.666	3.858	4.832	0.00018	0.00052	0.00058
3MMV9120HXCR	265	535	1600	3200	182.42	232.09	344.03	446.34	390.03	504.41	730.56	915.43	5.08	14.73	16.26
HX7020E-T-P4S	60	120	360	720	1.043	1.327	1.967	2.552	2.230	2.884	4.177	5.234	0.00020	0.00058	0.00064
3MMV9121HXCR	290	575	1735	3470	200.96	255.53	378.83	491.29	428.85	555.48	805.06	1009.00	5.08	14.22	15.75
HX7022E-T-P4S	65	130	390	780	1.149	1.461	2.166	2.809	2.452	3.176	4.603	5.769	0.00020	0.00056	0.00062
3MMV9124HXCR	355	710	2135	4270	217.93	277.22	411.02	533.10	468.56	606.90	879.22	1101.70	5.59	16.26	17.78
HX7024E-T-P4S	80	160	480	960	1.246	1.585	2.350	3.048	2.679	3.470	5.027	6.299	0.00022	0.00064	0.00070

**EXTRA-LIGHT ISO 10 SERIES**  
**2MMV9100HX (HX7000C-...-P4S)**  
**SPEED CAPABILITY DATA**

Fafnir Bearing Number	Timken ISO Bearing Number	Grease Capacity <sup>(1)</sup>				Operating Speeds <sup>(4)</sup> (DB Mounting) <sup>(5)</sup>					
		Low Speed <sup>(2)</sup>		High Speed <sup>(3)</sup>		Grease			Oil		
		25%	40%	10%	15%	DUL	DUM	DUH	DUL	DUM	DUH
		grams	grams	grams	grams	RPM	RPM	RPM	RPM	RPM	RPM
2MMV9100HXCR	HX7000C-T-P4S	0.30	0.40	0.10	0.20	70400	52800	35200	119700	89800	59800
2MMV9101HXCR	HX7001C-T-P4S	0.30	0.50	0.10	0.20	63100	47300	31600	107300	80400	53700
2MMV9102HXCR	HX7002C-T-P4S	0.40	0.70	0.15	0.30	51400	38600	25700	87400	65600	43700
2MMV9103HXCR	HX7003C-T-P4S	0.60	0.90	0.20	0.30	47100	35300	23600	80100	60000	40100
2MMV9104HXCR	HX7004C-T-P4S	1.00	1.60	0.40	0.60	39100	29300	19600	66500	49800	33300
2MMV9105HXCR	HX7005C-T-P4S	1.20	1.90	0.45	0.70	33400	25100	16700	56800	42700	28400
2MMV9106HXCR	HX7006C-T-P4S	1.70	2.70	0.65	1.00	27900	20900	14000	47400	35500	23800
2MMV9107HXCR	HX7007C-T-P4S	2.10	3.40	0.85	1.30	23800	17900	11900	40500	30400	20200
2MMV9108HXCR	HX7008C-T-P4S	2.70	4.30	1.05	1.50	21000	15700	10500	35700	26700	17900
2MMV9109HXCR	HX7009C-T-P4S	3.50	5.60	1.40	2.10	19100	14300	9600	32500	24300	16300
2MMV9110HXCR	HX7010C-T-P4S	3.90	6.20	1.55	2.30	17400	13100	8700	29600	22300	14800
2MMV9111HXCR	HX7011C-T-P4S	4.60	7.30	1.65	2.50	15000	11200	7500	25500	19000	12800
2MMV9112HXCR	HX7012C-T-P4S	4.90	7.90	1.80	2.70	13900	10400	7000	23600	17700	11900
2MMV9113HXCR	HX7013C-T-P4S	5.50	8.80	2.05	3.10	13100	9800	6600	22300	16700	11200
2MMV9114HXCR	HX7014C-T-P4S	7.30	11.70	2.70	4.10	12000	9000	6000	20400	15300	10200
2MMV9115HXCR	HX7015C-T-P4S	7.70	12.40	2.85	4.30	11400	8500	5700	19400	14500	9700
2MMV9116HXCR	HX7016C-T-P4S	10.30	16.50	3.85	5.80	10600	7900	5300	18000	13400	9000
2MMV9117HXCR	HX7017C-T-P4S	10.80	17.30	4.05	6.10	10100	7600	5000	17200	12900	8500
2MMV9118HXCR	HX7018C-T-P4S	13.20	21.00	4.85	7.20	9400	7000	4700	16000	11900	8000
2MMV9120HXCR	HX7020C-T-P4S	15.20	24.40	5.75	8.60	8600	6500	4300	14600	11100	7300
2MMV9122HXCR	HX7022C-T-P4S	21.50	34.30	7.85	11.80	7600	5700	3800	12900	9700	6500
2MMV9124HXCR	HX7024C-T-P4S	24.40	39.10	9.15	13.70	7100	5300	3600	12100	9000	6100

<sup>(1)</sup>Fill weights based on specific gravity of 0.99.

<sup>(2)</sup>Low speed <500000 dN.

<sup>(3)</sup>High speed > 500000 dN.

<sup>(4)</sup>For ceramic ball complements, use 120 percent of speeds shown.

<sup>(5)</sup>For other mounting arrangement configurations, refer to the engineering section on permissible speed calculation methods.

**EXTRA-LIGHT ISO 10 SERIES**  
**MMV9100HX (HX7000E-...-P4S)**  
**SPEED CAPABILITY DATA**

Fafnir Bearing Number	Timken ISO Bearing Number	Grease Capacity <sup>(1)</sup>				Operating Speeds <sup>(4)</sup> (DB Mounting) <sup>(5)</sup>					
		Low Speed <sup>(2)</sup>		High Speed <sup>(3)</sup>		Grease			Oil		
		25%	40%	10%	15%	DUL	DUM	DUH	DUL	DUM	DUH
		grams	grams	grams	grams	RPM	RPM	RPM	RPM	RPM	RPM
3MMV9100HXCR	HX7000E-T-P4S	0.30	0.40	0.10	0.20	61760	46320	30880	104220	81060	53850
3MMV9101HXCR	HX7001E-T-P4S	0.30	0.50	0.10	0.20	56800	42600	28400	95850	74550	49525
3MMV9102HXCR	HX7002E-T-P4S	0.40	0.70	0.15	0.30	46320	34740	23160	78165	60795	40385
3MMV9103HXCR	HX7003E-T-P4S	0.60	0.90	0.20	0.30	42400	31800	21200	71550	55650	36970
3MMV9104HXCR	HX7004E-T-P4S	1.00	1.60	0.40	0.60	35200	26400	17600	59400	46200	30690
3MMV9105HXCR	HX7005E-T-P4S	1.20	1.90	0.45	0.70	29280	21960	14640	49410	38430	25530
3MMV9106HXCR	HX7006E-T-P4S	1.70	2.70	0.65	1.00	24160	18120	12080	40770	31710	21065
3MMV9107HXCR	HX7007E-T-P4S	2.10	3.40	0.85	1.30	21440	16080	10720	36180	28140	18690
3MMV9108HXCR	HX7008E-T-P4S	2.70	4.30	1.05	1.50	18880	14160	9440	31860	24780	16460
3MMV9109HXCR	HX7009E-T-P4S	3.50	5.60	1.40	2.10	17200	12900	8600	29025	22575	15000
3MMV9110HXCR	HX7010E-T-P4S	3.90	6.20	1.55	2.30	15680	11760	7840	26460	20580	13675
3MMV9111HXCR	HX7011E-T-P4S	4.60	7.30	1.65	2.50	13520	10140	6760	22815	17745	11788
3MMV9112HXCR	HX7012E-T-P4S	4.90	7.90	1.80	2.70	12560	9420	6280	21195	16485	10950
3MMV9113HXCR	HX7013E-T-P4S	5.50	8.80	2.05	3.10	11840	8880	5920	19980	15540	10325
3MMV9114HXCR	HX7014E-T-P4S	7.30	11.70	2.70	4.10	10800	8100	5400	18225	14175	9415
3MMV9115HXCR	HX7015E-T-P4S	7.70	12.40	2.85	4.30	10160	7620	5080	17145	13335	8860
3MMV9116HXCR	HX7016E-T-P4S	10.30	16.50	3.85	5.80	9520	7140	4760	16065	12495	8300
3MMV9117HXCR	HX7017E-T-P4S	10.80	17.30	4.05	6.10	9040	6780	4520	15255	11865	7880
3MMV9118HXCR	HX7018E-T-P4S	13.20	21.00	4.85	7.20	8400	6300	4200	14175	11025	7325
3MMV9120HXCR	HX7020E-T-P4S	15.20	24.40	5.75	8.60	7760	5820	3880	13095	10185	6770
3MMV9122HXCR	HX7022E-T-P4S	21.50	34.30	7.85	11.80	6850	5135	3425	11560	8990	5970
3MMV9124HXCR	HX7024E-T-P4S	24.40	39.10	9.15	13.70	6425	4820	3210	10840	8430	5600

<sup>(1)</sup>Fill weights based on specific gravity of 0.99.

<sup>(2)</sup>Low speed <500000 dN.

<sup>(3)</sup>High speed > 500000 dN.

<sup>(4)</sup>For ceramic ball complements, use 120 percent of speeds shown.

<sup>(5)</sup>For other mounting arrangement configurations, refer to the engineering section on permissible speed calculation methods.

**ULTRA-LIGHT ISO 10 SERIES**

**MM9100K (6000-...-P4S)**

**SUPER PRECISION MMV**

Running accuracy and performance meet ABEC 9 (ISO P2) levels.  
Other features conform to ABEC 7 (ISO P4) requirements.

**DEEP-GROOVE (CONRAD) CONSTRUCTION**

- Incorporates high shoulder on both inner and outer rings.
- Balls separated by two-piece and piloted cage.

Bearing Number	d Bore	D O.D.	C Width <sup>(1)</sup>	Ball Qty. x Dia.	Bearing Wt.	Load Ratings						r Rad. <sup>(2)</sup>
						Steel Ball			Ceramic Ball			
						C <sub>0</sub> Static	C <sub>e</sub> Dynamic	Speed Rating <sup>(Ng)</sup>	C <sub>0</sub> Static	C <sub>e</sub> Dynamic	Speed Rating <sup>(Ng)</sup>	
mm in.	mm in.	mm in.	mm in.	kg lbs.	N lbs.	N lbs.	RPM	N lbs.	N lbs.	RPM	mm in.	
MM9101K 6001	12 0.4724	28 1.1024	8 0.3150	8 x 4.76 8 x 3/16	0.020 0.04	2400 540	5670 1280	52800 52800	2130 480	5670 1280	63400 63400	0.3 0.012
MM9103K 6003	17 0.6693	35 1.3780	10 0.3937	10 x 4.76 10 x 3/16	0.038 0.08	3300 735	6660 1500	39600 39600	2890 650	6660 1500	47500 47500	0.3 0.012
MM9104K 6004	20 0.7874	42 1.6535	12 0.4724	8 x 6.35 8 x 1/4	0.064 0.14	4400 1000	9620 2160	34000 34000	3980 890	9620 2160	40800 40800	0.6 0.024
MM9105K 6005	25 0.9843	47 1.8504	12 0.4724	10 x 6.35 10 x 1/4	0.074 0.16	5900 1320	11200 2510	28300 28300	5210 1170	11200 2510	34000 34000	0.6 0.024
MM9106K 6006	30 1.1811	55 2.1654	13 0.5118	11 x 7.14 11 x 9/32	0.109 0.24	8300 1860	14700 3300	23300 23300	7390 1660	14700 3300	28000 28000	1.0 0.039
MM9107K 6007	35 1.3780	62 2.4409	14 0.5512	11 x 7.94 11 x 5/16	0.144 0.32	10300 2320	17700 3980	20700 20700	9150 2060	17700 3980	24800 24800	1.0 0.039
MM9108K 6008	40 1.5748	68 2.6772	15 0.5906	12 x 7.94 12 x 5/16	0.180 0.40	11600 2600	18600 4180	18200 18200	10300 2310	18600 4180	21800 21800	1.0 0.039
MM9109K 6009	45 1.7717	75 2.9528	16 0.6299	13 x 8.73 13 x 11/32	0.230 0.51	15100 3400	23300 5230	16300 16300	13500 3030	23300 5230	19600 19600	1.0 0.039
MM9110K 6010	50 1.9685	80 3.1496	16 0.6299	14 x 8.73 14 x 11/32	0.248 0.55	16700 3750	24200 5440	14900 14900	14700 3310	24200 5440	17900 17900	1.0 0.039
MM9111K 6011	55 2.1654	90 3.5433	18 0.7087	13 x 10.32 13 x 13/32	0.362 0.80	21400 4800	31400 7050	13500 13500	18900 4250	31400 7050	16200 16200	1.0 0.039
MM9112K 6012	60 2.3622	95 3.7402	18 0.7087	14 x 10.32 14 x 13/32	0.430 0.95	23200 5210	32600 7340	12500 12500	20600 4630	32600 7340	15000 15000	1.0 0.039
MM9113K 6013	65 2.5591	100 3.9370	18 0.7087	15 x 10.32 15 x 13/32	0.450 0.99	25200 5650	33900 7610	11600 11600	22400 5030	33900 7610	13900 13900	1.0 0.039
MM9114K 6014	70 2.7559	110 4.3307	20 0.7874	14 x 11.91 14 x 15/32	0.620 1.37	30900 6940	42200 9490	10700 10700	27500 6180	42200 9490	12800 12800	1.0 0.039
MM9115K 6015	75 2.9528	115 4.5276	20 0.7874	15 x 11.91 15 x 15/32	0.606 1.34	33400 7500	43800 9850	10100 10100	29800 6700	43800 9850	12100 12100	1.0 0.039
MM9116K 6016	80 3.1496	125 4.9213	22 0.8661	14 x 13.49 14 x 17/32	0.804 1.77	40000 9000	52800 11900	9420 9420	35300 7940	52800 11900	11300 11300	1.0 0.039
MM9117K 6017	85 3.3465	130 5.1181	22 0.8661	15 x 13.49 15 x 17/32	0.845 1.86	42900 9650	54900 12300	8900 8900	38300 8600	54900 12300	10700 10700	1.0 0.039
MM9118K 6018	90 3.5433	140 5.5118	24 0.9449	14 x 15.08 14 x 19/32	1.092 2.41	49800 11200	64500 14500	8390 8390	44100 9920	64500 14500	10100 10100	1.5 0.059
MM9120K 6020	100 3.9370	150 5.9055	24 0.9449	15 x 15.08 15 x 19/32	1.208 2.66	54300 12200	66700 15000	7630 7630	48200 10800	66700 15000	9160 9160	1.5 0.059
MM9122K 6022	110 4.3307	170 6.6929	28 1.1024	14 x 17.46 14 x 11/16	1.882 4.15	66700 15000	83400 18700	6840 6840	59900 13500	83400 18700	8210 8210	2.0 0.079
MM9124K 6024	120 4.7244	180 7.0866	28 1.1024	15 x 17.46 15 x 11/16	2.019 4.45	72500 16300	86300 19400	6320 6320	65000 14600	86300 19400	7580 7580	2.0 0.079
MM9126K 6026	130 5.1181	200 7.8740	33 1.2992	14 x 20.64 14 x 13/16	3.041 6.70	94300 21200	112600 25300	5810 5810	83600 18800	112600 25300	6975 6975	2.0 0.079

<sup>(Ng)</sup>For a single, grease-lubricated, spring-preloaded bearing. This value to be used in permissible operating speed (Sp) calculation.

<sup>(1)</sup>Width tolerance of preloaded bearing set +0.000/-0.254 mm (+0.0000/-0.0100 in.).

<sup>(2)</sup>ABMA STD 20 (ras max).



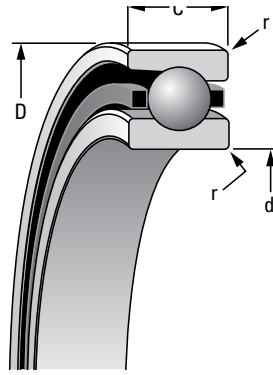

Suggested Shoulder Diameters				Shaft Diameter		Mounting Fits		Fixed				Floating			
Shaft		Housing						Housing Bore (Stationary)		Mounting Fits		Housing Bore (Stationary)		Mounting Fits	
Max.	Min.	Max.	Min.	Max.	Min.	Loose	Tight	Max.	Min.	Tight	Loose	Max.	Min.	Loose	Loose
mm in.	mm in.	mm in.	mm in.	mm in.	mm in.	mm in.	mm in.	mm in.	mm in.	mm in.	mm in.	mm in.	mm in.	mm in.	mm in.
16.1 0.64	15.9 0.63	25.5 1.01	25.3 1.00	12.000 0.47240	11.995 0.47220	0.005 0.00020	0.004 0.00015	28.005 1.10260	28.000 1.10240	0.000 0.00000	0.010 0.00040	28.010 1.10280	28.005 1.10260	0.015 0.00060	0.005 0.00020
21.7 0.86	21.5 0.85	31.1 1.23	30.9 1.22	17.000 0.66930	16.995 0.66910	0.005 0.00020	0.004 0.00015	35.006 1.37830	35.000 1.37800	0.000 0.00000	0.012 0.00050	35.010 1.37840	35.005 1.37820	0.016 0.00070	0.005 0.00020
25.0 0.99	24.8 0.98	37.7 1.49	37.5 1.48	20.000 0.78740	19.995 0.78720	0.005 0.00020	0.005 0.00020	42.006 1.65380	42.000 1.65350	0.000 0.00000	0.012 0.00050	42.010 1.65390	42.005 1.65370	0.016 0.00070	0.005 0.00020
30.1 1.19	29.9 1.18	42.6 1.68	42.3 1.67	25.000 0.98430	24.995 0.98410	0.005 0.00020	0.005 0.00020	47.006 1.85070	47.000 1.85040	0.000 0.00000	0.012 0.00050	47.012 1.85090	47.007 1.85070	0.018 0.00080	0.007 0.00030
36.2 1.43	35.9 1.42	50.7 2.00	50.4 1.99	30.000 1.18110	29.995 1.18090	0.005 0.00020	0.005 0.00020	55.008 2.16570	55.000 2.16540	0.000 0.00000	0.015 0.00060	55.012 2.16590	55.007 2.16570	0.019 0.00080	0.007 0.00030
41.2 1.62	40.6 1.60	56.6 2.23	56.1 2.21	35.000 1.37800	34.995 1.37780	0.005 0.00020	0.006 0.00025	62.008 2.44120	62.000 2.44090	0.000 0.00000	0.015 0.00060	62.012 2.44140	62.007 2.44120	0.019 0.00080	0.007 0.00030
46.2 1.82	45.7 1.80	62.2 2.45	61.7 2.43	40.000 1.57480	39.995 1.57460	0.005 0.00020	0.006 0.00025	68.008 2.67750	68.000 2.67720	0.000 0.00000	0.015 0.00060	68.012 2.67770	68.007 2.67750	0.019 0.00080	0.007 0.00030
51.8 2.04	51.3 2.02	69.3 2.73	68.8 2.71	45.000 1.77170	44.995 1.77150	0.005 0.00020	0.006 0.00025	75.008 2.95310	75.000 2.95280	0.000 0.00000	0.015 0.00060	75.014 2.95330	75.009 2.95310	0.022 0.00080	0.009 0.00030
56.6 2.23	56.1 2.21	74.2 2.92	73.7 2.90	50.000 1.96850	49.995 1.96830	0.005 0.00020	0.006 0.00025	80.008 3.14990	80.000 3.14960	0.000 0.00000	0.015 0.00060	80.012 3.15010	80.008 3.14990	0.020 0.00080	0.008 0.00030
62.7 2.47	62.2 2.45	83.3 3.28	82.8 3.26	55.000 2.16540	54.995 2.16520	0.005 0.00020	0.007 0.00030	90.008 3.54360	90.000 3.54330	0.000 0.00000	0.016 0.00060	90.015 3.54390	90.007 3.54360	0.023 0.00090	0.007 0.00030
67.8 2.67	67.3 2.65	88.1 3.47	87.6 3.45	60.000 2.36220	59.995 2.36200	0.005 0.00020	0.007 0.00030	95.008 3.74050	95.000 3.74020	0.000 0.00000	0.016 0.00060	95.016 3.74080	95.009 3.74050	0.024 0.00090	0.009 0.00030
72.6 2.86	72.1 2.84	93.2 3.67	92.7 3.65	65.000 2.55910	64.995 2.55890	0.005 0.00020	0.007 0.00030	100.008 3.93730	100.000 3.93700	0.000 0.00000	0.016 0.00060	100.018 3.93770	100.010 3.93740	0.025 0.00100	0.010 0.00040
78.2 3.08	77.7 3.06	102.4 4.03	101.9 4.01	70.000 2.75590	69.995 2.75570	0.005 0.00020	0.007 0.00030	110.008 4.33100	110.000 4.33070	0.000 0.00000	0.016 0.00060	110.018 4.33140	110.010 4.33110	0.025 0.00100	0.010 0.00040
83.4 3.29	82.7 3.26	107.3 4.23	106.6 4.20	75.005 2.95300	74.995 2.95260	0.005 0.00020	0.012 0.00050	115.008 4.52790	115.000 4.52760	0.000 0.00000	0.016 0.00060	115.019 4.52830	115.011 4.52800	0.026 0.00100	0.010 0.00040
89.3 3.52	88.5 3.49	116.5 4.59	115.7 4.56	80.005 3.14980	79.995 3.14940	0.005 0.00020	0.012 0.00050	125.008 4.92160	125.000 4.92130	0.000 0.00000	0.017 0.00070	125.021 4.92210	125.011 4.92170	0.030 0.00120	0.011 0.00040
94.9 3.74	94.1 3.71	122.1 4.81	121.3 4.78	85.005 3.34670	84.995 3.34630	0.005 0.00020	0.012 0.00050	130.009 5.11850	130.000 5.11810	0.000 0.00000	0.018 0.00070	130.020 5.11890	130.010 5.11850	0.029 0.00110	0.010 0.00040
100.5 3.96	99.7 3.93	130.9 5.16	130.2 5.13	90.005 3.54350	89.995 3.54310	0.005 0.00020	0.013 0.00050	140.009 5.51220	140.000 5.51180	0.000 0.00000	0.018 0.00070	140.020 5.51260	140.010 5.51220	0.029 0.00110	0.010 0.00040
110.6 4.36	109.9 4.33	140.8 5.55	140.1 5.52	100.005 3.93720	99.995 3.93680	0.005 0.00020	0.013 0.00050	150.009 5.90590	150.000 5.90550	0.000 0.00000	0.018 0.00070	150.023 5.90640	150.012 5.90600	0.032 0.00120	0.012 0.00050
123.1 4.85	122.3 4.82	158.4 6.24	157.6 6.21	110.005 4.33090	109.995 4.33050	0.005 0.00020	0.013 0.00050	170.010 6.69330	170.000 6.69290	0.000 0.00000	0.020 0.00080	170.022 6.69380	170.012 6.69340	0.032 0.00130	0.012 0.00050
133.2 5.25	132.5 5.22	168.3 6.63	167.5 6.60	120.005 4.72460	119.995 4.72420	0.005 0.00020	0.013 0.00050	180.010 7.08700	180.000 7.08660	0.000 0.00000	0.020 0.00080	180.022 7.08750	180.012 7.08710	0.032 0.00130	0.012 0.00050
144.9 5.71	144.2 5.68	186.6 7.35	185.8 7.32	130.005 5.11830	129.995 5.11790	0.005 0.00020	0.015 0.00060	200.011 7.87450	200.000 7.87400	0.000 0.00000	0.022 0.00090	200.025 7.87500	200.015 7.87460	0.036 0.00150	0.015 0.00060

**LIGHT ISO 02 SERIES**

**2(3)MV/MM200WI (7200C(E)-...-P4/P4S)**

**HIGH PRECISION MV**

Running accuracy, performance and dimensional controls conform to ABEC 7 (ISO P4) requirements.

**SUPER PRECISION MM**

Running accuracy and performance meet ABEC 9 (ISO P2) levels. Other features conform to ABEC 7 (ISO P4) requirements.

**WI CONSTRUCTION**

- Incorporates low shoulder on non-thrust side of outer rings.
- Balls separated by one-piece cage piloted against a ground thrust shoulder land of the outer ring.
- Optional one-piece cage piloted on the ball available with MV (P4) product.

Bearing Number 15° C/2 <sup>(3)</sup> or 25° E/3 <sup>(4)</sup>	d Bore	D O.D.	C Width <sup>(1)</sup>	Ball Qty. x Dia.	Bearing Wt.	15° (C/2) Load Ratings						25° (E/3) Load Ratings					
						Steel Ball			Ceramic Ball			Steel Ball			Ceramic Ball		
						C <sub>0</sub> Static	C <sub>e</sub> Dynamic	Speed Rating <sup>(N<sub>g</sub>)</sup>	C <sub>0</sub> Static	C <sub>e</sub> Dynamic	Speed Rating <sup>(N<sub>g</sub>)</sup>	C <sub>0</sub> Static	C <sub>e</sub> Dynamic	Speed Rating <sup>(N<sub>g</sub>)</sup>	C <sub>0</sub> Static	C <sub>e</sub> Dynamic	Speed Rating <sup>(N<sub>g</sub>)</sup>
mm in.	mm in.	mm in.	mm in.	kg lbs.	N lbs.	N lbs.	RPM	N lbs.	N lbs.	RPM	N lbs.	N lbs.	RPM	N lbs.	N lbs.	RPM	
200WI 7200	10 0.3937	30 1.1811	9 0.3543	8 x 5.56 8 x 7/32	0.030 0.07	2900 660	7100 1600	62800 62800	2610 590	7100 1600	75400 75400	2800 640	6900 1550	56500 56500	2540 570	6900 1550	67800 67800
201WI 7201	12 0.4724	32 1.2598	10 0.3937	9 x 5.95 9 x 15/64	0.036 0.08	3800 860	8760 1970	56700 56700	3410 770	8760 1970	68000 68000	3700 830	8500 1910	51000 51000	3320 750	8500 1910	61200 61200
202WI 7202	15 0.5906	35 1.3780	11 0.4331	10 x 5.95 10 x 15/64	0.044 0.10	4500 1010	9580 2200	47800 47800	4010 900	9580 2200	57400 57400	4400 980	9250 2080	43000 43000	3880 870	9250 2080	51600 51600
203WI 7203	17 0.6693	40 1.5748	12 0.4724	10 x 6.75 10 x 17/64	0.064 0.14	5900 1320	12000 2750	41900 41900	5170 1160	12000 2750	50300 50300	5600 1270	11600 2600	37700 37700	5000 1120	11600 2600	45200 45200
204WI 7204	20 0.7874	47 1.8504	14 0.5512	10 x 7.94 10 x 3/8	0.103 0.23	8100 1810	16100 3620	35700 35700	7160 1610	16100 3620	42800 42800	7700 1730	15500 3490	32100 32100	6900 1550	15500 3490	38500 38500
205WI 7205	25 0.9843	52 2.0472	15 0.5906	12 x 7.94 12 x 3/8	0.127 0.28	10200 2320	18400 4130	29800 29800	9110 2050	18400 4130	35800 35800	9800 2200	17600 3950	26800 26800	8690 1950	17600 3950	32200 32100
206WI 7206	30 1.1811	62 2.4409	16 0.6299	12 x 9.53 12 x 3/8	0.195 0.43	14700 3310	25500 5740	25100 25100	13100 2940	25500 5740	30100 30100	14000 3150	24400 5490	22600 22600	12500 2810	24400 5490	27100 27100
207WI 7207	35 1.3780	72 2.8346	17 0.6693	12 x 11.11 12 x 7/16	0.282 0.62	20000 4490	33700 7580	21600 21600	17800 4000	33700 7580	25900 25900	19100 4300	32200 7240	19400 19400	17100 3820	32200 7240	23300 23300
208WI 7208	40 1.5748	80 3.1496	18 0.7087	11 x 12.70 11 x 1/2	0.352 0.78	23800 5340	40400 9070	19300 19300	21100 4750	40400 9070	23100 23200	22700 5100	38700 8690	17400 17400	20200 4550	38700 8690	20900 20900
209WI 7209	45 1.7717	85 3.3465	19 0.7480	13 x 12.70 13 x 1/2	0.408 0.90	28800 6470	45200 10200	17500 17500	25600 5760	45200 10200	21000 21000	27600 6200	43100 9700	15800 15800	24500 5500	43100 9700	19000 19000
210WI 7210	50 1.9685	90 3.5433	20 0.7874	14 x 12.70 14 x 1/2	0.457 1.01	31700 7130	47400 10700	16000 16000	28200 6340	47400 10700	19200 19200	30200 6800	45200 10200	14400 14400	26900 6050	45200 10200	17300 17300
211WI 7211	55 2.1654	100 3.9370	21 0.8268	14 x 14.29 14 x 9/16	0.608 1.34	40000 9000	58700 13200	14500 14500	35500 7980	58700 13200	17400 17400	38500 8650	55900 12600	13100 13100	34000 7640	55900 12600	15700 15700
212WI 7212	60 2.3622	110 4.3307	22 0.8661	14 x 15.88 14 x 3/8	0.787 1.74	48900 11000	71000 16000	13200 13200	43600 9810	71000 16000	15800 15800	47100 10600	67700 15200	11900 11900	41800 9400	67700 15200	14300 14300
213WI 7213	65 2.5591	120 4.7244	23 0.9055	14 x 16.67 14 x 27/32	0.998 2.20	54700 12300	77400 17400	12100 12100	48700 11000	77400 17400	14300 14500	52500 11800	73700 16600	10900 10900	46500 10400	73700 16600	13100 13100

<sup>(N<sub>g</sub>)</sup>For a single, grease-lubricated, spring-preloaded bearing. This value to be used in permissible operating speed (Sp) calculation.

<sup>(1)</sup>Width tolerance of preloaded bearing set +0.000/-0.254 mm (+0.0000/-0.0100 in.).

<sup>(2)</sup>Fill weights based upon specific gravity of 0.99.

<sup>(3)</sup>C is ISO designation for 15° contact angle, 2 is Timken designation for 15° contact angle.

<sup>(4)</sup>E is ISO designation for 25° contact angle, 3 is Timken designation for 25° contact angle.

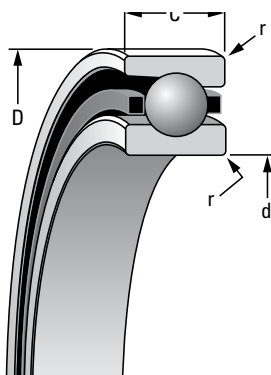

r Rad. <sup>(2)</sup>	Suggested Shoulder Diameters				Shaft Diameter		Mounting Fits		Fixed				Floating			
	Shaft		Housing						Housing Bore (Stationary)		Mounting Fits		Housing Bore (Stationary)		Mounting Fits	
	Max.	Min.	Max.	Min.	Max.	Min.	Loose	Tight	Max.	Min.	Tight	Loose	Max.	Min.	Loose	Loose
mm in.	mm in.	mm in.	mm in.	mm in.	mm in.	mm in.	mm in.	mm in.	mm in.	mm in.	mm in.	mm in.	mm in.	mm in.	mm in.	mm in.
<b>0.6</b> 0.024	<b>15.1</b> 0.60	<b>14.9</b> 0.59	<b>26.0</b> 1.03	<b>25.8</b> 1.02	<b>10.000</b> 0.39370	<b>9.995</b> 0.39350	<b>0.005</b> 0.00020	<b>0.004</b> 0.00015	<b>30.005</b> 1.18130	<b>30.000</b> 1.18110	<b>0.000</b> 0.00000	<b>0.010</b> 0.00040	<b>30.010</b> 1.18150	<b>30.005</b> 1.18130	<b>0.015</b> 0.00060	<b>0.005</b> 0.00020
<b>0.6</b> 0.024	<b>16.6</b> 0.66	<b>16.4</b> 0.65	<b>28.1</b> 1.11	<b>27.8</b> 1.10	<b>12.000</b> 0.47240	<b>11.995</b> 0.47220	<b>0.005</b> 0.00020	<b>0.004</b> 0.00015	<b>32.005</b> 1.26000	<b>32.000</b> 1.25980	<b>0.000</b> 0.00000	<b>0.011</b> 0.00045	<b>32.010</b> 1.26020	<b>32.005</b> 1.26000	<b>0.016</b> 0.00070	<b>0.005</b> 0.00020
<b>0.6</b> 0.024	<b>19.2</b> 0.76	<b>18.9</b> 0.75	<b>31.1</b> 1.23	<b>30.9</b> 1.22	<b>15.000</b> 0.59060	<b>14.995</b> 0.59040	<b>0.005</b> 0.00020	<b>0.004</b> 0.00015	<b>35.006</b> 1.37830	<b>35.000</b> 1.37800	<b>0.000</b> 0.00000	<b>0.012</b> 0.00050	<b>35.010</b> 1.37840	<b>35.005</b> 1.37820	<b>0.016</b> 0.00070	<b>0.005</b> 0.00020
<b>0.6</b> 0.024	<b>21.7</b> 0.86	<b>21.5</b> 0.85	<b>35.7</b> 1.41	<b>35.4</b> 1.40	<b>17.000</b> 0.66930	<b>16.995</b> 0.66910	<b>0.005</b> 0.00020	<b>0.004</b> 0.00015	<b>40.006</b> 1.57510	<b>40.000</b> 1.57480	<b>0.000</b> 0.00000	<b>0.012</b> 0.00050	<b>40.010</b> 1.57520	<b>40.005</b> 1.57500	<b>0.016</b> 0.00070	<b>0.005</b> 0.00020
<b>1.0</b> 0.039	<b>26.0</b> 1.03	<b>25.8</b> 1.02	<b>41.5</b> 1.64	<b>41.3</b> 1.63	<b>20.000</b> 0.78740	<b>19.995</b> 0.78720	<b>0.005</b> 0.00020	<b>0.005</b> 0.00020	<b>47.006</b> 1.85070	<b>47.000</b> 1.85040	<b>0.000</b> 0.00000	<b>0.012</b> 0.00050	<b>47.012</b> 1.85090	<b>47.007</b> 1.85070	<b>0.018</b> 0.00080	<b>0.007</b> 0.00030
<b>1.0</b> 0.039	<b>31.1</b> 1.23	<b>30.9</b> 1.22	<b>47.1</b> 1.86	<b>46.9</b> 1.85	<b>25.000</b> 0.98430	<b>24.995</b> 0.98410	<b>0.005</b> 0.00020	<b>0.005</b> 0.00020	<b>52.006</b> 2.04750	<b>52.000</b> 2.04720	<b>0.000</b> 0.00000	<b>0.013</b> 0.00055	<b>52.012</b> 2.04770	<b>52.007</b> 2.04750	<b>0.019</b> 0.00080	<b>0.007</b> 0.00030
<b>1.0</b> 0.039	<b>36.7</b> 1.45	<b>36.5</b> 1.44	<b>56.0</b> 2.21	<b>55.8</b> 2.20	<b>30.000</b> 1.18110	<b>29.995</b> 1.18090	<b>0.005</b> 0.00020	<b>0.005</b> 0.00020	<b>62.008</b> 2.44120	<b>62.000</b> 2.44090	<b>0.000</b> 0.00000	<b>0.015</b> 0.00060	<b>62.012</b> 2.44140	<b>62.007</b> 2.44120	<b>0.019</b> 0.00080	<b>0.007</b> 0.00030
<b>1.0</b> 0.039	<b>42.7</b> 1.68	<b>42.2</b> 1.66	<b>65.3</b> 2.57	<b>64.8</b> 2.55	<b>35.000</b> 1.37800	<b>34.995</b> 1.37780	<b>0.005</b> 0.00020	<b>0.006</b> 0.00025	<b>72.008</b> 2.83490	<b>72.000</b> 2.83460	<b>0.000</b> 0.00000	<b>0.015</b> 0.00060	<b>72.011</b> 2.83510	<b>72.007</b> 2.83490	<b>0.019</b> 0.00080	<b>0.007</b> 0.00030
<b>1.0</b> 0.039	<b>47.8</b> 1.88	<b>47.2</b> 1.86	<b>73.2</b> 2.88	<b>72.6</b> 2.86	<b>40.000</b> 1.57480	<b>39.995</b> 1.57460	<b>0.005</b> 0.00020	<b>0.006</b> 0.00025	<b>80.008</b> 3.14990	<b>80.000</b> 3.14960	<b>0.000</b> 0.00000	<b>0.015</b> 0.00060	<b>80.012</b> 3.15010	<b>80.008</b> 3.14990	<b>0.020</b> 0.00080	<b>0.008</b> 0.00030
<b>1.0</b> 0.039	<b>52.8</b> 2.08	<b>52.3</b> 2.06	<b>78.2</b> 3.08	<b>77.7</b> 3.06	<b>45.000</b> 1.77170	<b>44.995</b> 1.77150	<b>0.005</b> 0.00020	<b>0.006</b> 0.00025	<b>85.008</b> 3.34680	<b>85.000</b> 3.34650	<b>0.000</b> 0.00000	<b>0.016</b> 0.00060	<b>85.016</b> 3.34710	<b>85.009</b> 3.34680	<b>0.024</b> 0.00090	<b>0.009</b> 0.00030
<b>1.0</b> 0.039	<b>57.9</b> 2.28	<b>57.4</b> 2.26	<b>83.3</b> 3.28	<b>82.8</b> 3.26	<b>50.000</b> 1.96850	<b>49.995</b> 1.96830	<b>0.005</b> 0.00020	<b>0.006</b> 0.00025	<b>90.008</b> 3.54360	<b>90.000</b> 3.54330	<b>0.000</b> 0.00000	<b>0.016</b> 0.00060	<b>90.015</b> 3.54390	<b>90.007</b> 3.54360	<b>0.023</b> 0.00090	<b>0.007</b> 0.00030
<b>1.5</b> 0.059	<b>63.8</b> 2.51	<b>63.3</b> 2.49	<b>92.2</b> 3.63	<b>91.7</b> 3.61	<b>55.000</b> 2.16540	<b>54.995</b> 2.16520	<b>0.005</b> 0.00020	<b>0.007</b> 0.00030	<b>100.008</b> 3.93730	<b>100.000</b> 3.93700	<b>0.000</b> 0.00000	<b>0.016</b> 0.00060	<b>100.018</b> 3.93770	<b>100.010</b> 3.93740	<b>0.025</b> 0.00100	<b>0.010</b> 0.00040
<b>1.5</b> 0.059	<b>69.9</b> 2.75	<b>69.3</b> 2.73	<b>101.4</b> 3.99	<b>100.8</b> 3.97	<b>60.000</b> 2.36220	<b>59.995</b> 2.36200	<b>0.005</b> 0.00020	<b>0.007</b> 0.00030	<b>110.008</b> 4.33100	<b>110.000</b> 4.33070	<b>0.000</b> 0.00000	<b>0.016</b> 0.00060	<b>110.018</b> 4.33140	<b>110.010</b> 4.33110	<b>0.025</b> 0.00100	<b>0.010</b> 0.00040
<b>1.5</b> 0.059	<b>76.2</b> 3.00	<b>75.7</b> 2.98	<b>109.7</b> 4.32	<b>109.2</b> 4.30	<b>65.000</b> 2.55910	<b>64.995</b> 2.55890	<b>0.005</b> 0.00020	<b>0.007</b> 0.00030	<b>120.008</b> 4.72470	<b>120.000</b> 4.72440	<b>0.000</b> 0.00000	<b>0.016</b> 0.00060	<b>120.018</b> 4.72510	<b>120.010</b> 4.72480	<b>0.025</b> 0.00100	<b>0.010</b> 0.00040

*Continued on next page.*

**LIGHT ISO 02 SERIES — continued**  
**2(3)MV/MM200WI (7200C(E)-...-P4/P4S)**  
**HIGH PRECISION MV**

Running accuracy, performance and dimensional controls conform to ABEC 7 (ISO P4) requirements.

**SUPER PRECISION MM**

Running accuracy and performance meet ABEC 9 (ISO P2) levels. Other features conform to ABEC 7 (ISO P4) requirements.

**WI CONSTRUCTION**

- Incorporates low shoulder on non-thrust side of outer rings.
- Balls separated by one-piece cage piloted against a ground thrust shoulder land of the outer ring.
- Optional one-piece cage piloted on the ball available with MV (P4) product.

Bearing Number 15° C/2 <sup>(3)</sup> or 25° E/3 <sup>(4)</sup>	d Bore	D O.D.	C Width <sup>(1)</sup>	Ball Qty. x Dia.	Bearing Wt. kg lbs.	15° (C/2) Load Ratings						25° (E/3) Load Ratings					
						Steel Ball			Ceramic Ball			Steel Ball			Ceramic Ball		
						C <sub>0</sub> Static	C <sub>e</sub> Dynamic	Speed Rating <sup>(N<sub>g</sub>)</sup>	C <sub>0</sub> Static	C <sub>e</sub> Dynamic	Speed Rating <sup>(N<sub>g</sub>)</sup>	C <sub>0</sub> Static	C <sub>e</sub> Dynamic	Speed Rating <sup>(N<sub>g</sub>)</sup>	C <sub>0</sub> Static	C <sub>e</sub> Dynamic	Speed Rating <sup>(N<sub>g</sub>)</sup>
mm in.	mm in.	mm in.	mm in.	kg lbs.	N lbs.	N lbs.	RPM	N lbs.	N lbs.	RPM	N lbs.	N lbs.	RPM	N lbs.	N lbs.	RPM	
214WI 7214	70 2.7559	125 4.9213	24 0.9449	14 x 17.46 14 x 1 1/16	1.074 2.37	60000 13400	84200 18900	11400 11400	53600 12100	84200 18900	13700 13700	57400 12900	80200 18000	10300 10300	51100 11500	80200 18000	12400 12400
215WI 7215	75 2.9528	130 5.1181	25 0.9843	15 x 17.46 15 x 1 1/16	1.174 2.59	64900 14600	87900 19800	10800 10800	58200 13100	87900 19800	13000 13000	62300 14000	83700 18800	9700 9700	55600 12500	83700 18800	11600 11600
216WI 7216	80 3.1496	140 5.5118	26 1.0236	15 x 19.05 15 x 3/4	1.448 3.19	77000 17300	102900 23100	10100 10100	69000 15500	102900 23100	12100 12100	73800 16600	98000 22000	9100 9100	65800 14800	98000 22000	10900 10900
217WI 7217	85 3.3465	150 5.9055	28 1.1024	15 x 20.64 15 x 13/16	1.817 4.01	90700 20400	118900 26700	9400 9400	80700 18200	118900 26700	11300 11300	85800 19300	113300 25500	8500 8500	76800 17300	113300 25500	10200 10200
218WI 7218	90 3.5433	160 6.2992	30 1.1811	14 x 22.23 14 x 7/8	2.196 4.84	97900 22000	129900 29200	8900 8900	87100 19600	129900 29200	10700 10700	92500 20800	123700 27800	8000 8000	82900 18600	123700 27800	9600 9600
219WI 7219	95 3.7402	170 6.6929	32 1.2598	14 x 23.81 14 x 15/16	2.669 5.88	111200 25000	147100 33100	8400 8400	99600 22400	147100 33100	10100 10100	106800 24000	140100 31500	7600 7600	94900 21300	140100 31500	9100 9100
220WI 7220	100 3.9370	180 7.0866	34 1.3386	14 x 25.40 14 x 1	3.209 7.07	126800 28500	165200 37100	8000 8000	112900 25400	165200 37100	9600 9600	120100 27000	15500 35400	7200 7200	107800 24200	157500 35400	8600 8600
222WI 7222	110 4.3307	200 7.8740	38 1.4961	14 x 28.58 14 x 1 1/8	4.486 9.89	160100 36000	194900 43800	7200 7200	142000 31900	194900 43800	8600 8600	153500 34500	185800 41800	6500 6500	135900 30600	185800 41800	7800 7800
224WI 7224	120 4.7244	215 8.4646	40 1.5748	14 x 30.16 14 x 1 3/16	5.358 11.81	180100 40500	210100 47200	6700 6700	159600 35900	210100 47200	8000 8000	173500 39000	200500 45100	6000 6000	152400 34300	200500 45100	7200 7200
226WI 7226	130 5.1181	230 9.0551	40 1.5748	17 x 30.16 17 x 1 3/16	6.468 14.26	222400 50000	238200 53500	6100 6100	197400 44400	238200 53500	7300 7300	211300 47500	226800 51000	5500 5500	188800 42500	226800 51000	6600 6600
230WI 7230	150 5.9055	270 10.6299	45 1.7717	15 x 38.10 15 x 1 1/2	9.980 22.00	302500 68000	305200 68600	5300 5300	272100 61200	305200 68600	6400 6400	291300 65500	290900 65400	4800 4800	259900 58400	290900 65400	5800 5800

<sup>(N<sub>g</sub>)</sup>For a single, grease-lubricated, spring-preloaded bearing. This value to be used in permissible operating speed (Sp) calculation.

<sup>(1)</sup>Width tolerance of preloaded bearing set +0.000/-0.254 mm (+0.0000/-0.0100 in.).

<sup>(2)</sup>Fill weights based upon specific gravity of 0.99.

<sup>(3)</sup>C is ISO designation for 15° contact angle, 2 is Timken designation for 15° contact angle.

<sup>(4)</sup>E is ISO designation for 25° contact angle, 3 is Timken designation for 25° contact angle.

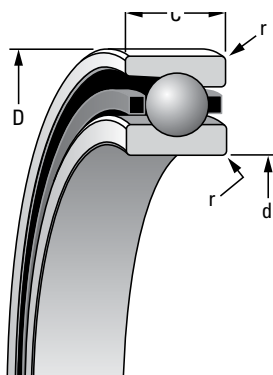

r Rad. <sup>(2)</sup>	Suggested Shoulder Diameters				Shaft Diameter		Mounting Fits		Fixed				Floating			
	Shaft		Housing						Housing Bore (Stationary)		Mounting Fits		Housing Bore (Stationary)		Mounting Fits	
	Max.	Min.	Max.	Min.	Max.	Min.	Loose	Tight	Max.	Min.	Tight	Loose	Max.	Min.	Loose	Loose
mm in.	mm in.	mm in.	mm in.	mm in.	mm in.	mm in.	mm in.	mm in.	mm in.	mm in.	mm in.	mm in.	mm in.	mm in.	mm in.	mm in.
<b>1.5</b> 0.059	<b>80.8</b> 3.18	<b>80.3</b> 3.16	<b>115.8</b> 4.56	<b>115.3</b> 4.54	<b>70.000</b> 2.75590	<b>69.995</b> 2.75570	<b>0.005</b> 0.00020	<b>0.007</b> 0.00030	<b>125.008</b> 4.92160	<b>125.000</b> 4.92130	<b>0.000</b> 0.00000	<b>0.017</b> 0.00070	<b>125.021</b> 4.92210	<b>125.011</b> 4.92170	<b>0.030</b> 0.00120	<b>0.011</b> 0.00040
<b>1.5</b> 0.059	<b>86.0</b> 3.39	<b>85.2</b> 3.36	<b>120.8</b> 4.76	<b>120.0</b> 4.73	<b>75.005</b> 2.95300	<b>74.995</b> 2.95260	<b>0.005</b> 0.00020	<b>0.012</b> 0.00050	<b>130.009</b> 5.11850	<b>130.000</b> 5.11810	<b>0.000</b> 0.00000	<b>0.018</b> 0.00070	<b>130.020</b> 5.11890	<b>130.010</b> 5.11850	<b>0.029</b> 0.00110	<b>0.010</b> 0.00040
<b>2.0</b> 0.079	<b>91.3</b> 3.60	<b>90.6</b> 3.57	<b>129.9</b> 5.12	<b>129.2</b> 5.09	<b>80.005</b> 3.14980	<b>79.995</b> 3.14940	<b>0.005</b> 0.00020	<b>0.012</b> 0.00050	<b>140.009</b> 5.51220	<b>140.000</b> 5.51180	<b>0.000</b> 0.00000	<b>0.018</b> 0.00070	<b>140.020</b> 5.51260	<b>140.010</b> 5.51220	<b>0.029</b> 0.00110	<b>0.010</b> 0.00040
<b>2.0</b> 0.079	<b>97.4</b> 3.84	<b>96.7</b> 3.81	<b>138.8</b> 5.47	<b>138.1</b> 5.44	<b>85.005</b> 3.34670	<b>84.995</b> 3.34630	<b>0.005</b> 0.00020	<b>0.012</b> 0.00050	<b>150.009</b> 5.90590	<b>150.000</b> 5.90550	<b>0.000</b> 0.00000	<b>0.018</b> 0.00070	<b>150.023</b> 5.90640	<b>150.012</b> 5.90600	<b>0.032</b> 0.00120	<b>0.012</b> 0.00050
<b>2.0</b> 0.079	<b>103.5</b> 4.08	<b>102.7</b> 4.05	<b>148.0</b> 5.83	<b>147.2</b> 5.80	<b>90.005</b> 3.54350	<b>89.995</b> 3.54310	<b>0.005</b> 0.00020	<b>0.013</b> 0.00050	<b>160.009</b> 6.29960	<b>160.000</b> 6.29920	<b>0.000</b> 0.00000	<b>0.022</b> 0.00080	<b>160.022</b> 6.30010	<b>160.012</b> 6.29970	<b>0.033</b> 0.00130	<b>0.012</b> 0.00050
<b>2.1</b> 0.079	<b>109.4</b> 4.31	<b>108.6</b> 4.28	<b>157.1</b> 6.19	<b>153.3</b> 6.16	<b>95.005</b> 3.74040	<b>94.995</b> 3.74000	<b>0.005</b> 0.00020	<b>0.013</b> 0.00050	<b>170.010</b> 6.69330	<b>170.000</b> 6.69290	<b>0.000</b> 0.00000	<b>0.020</b> 0.00080	<b>170.022</b> 6.69380	<b>170.012</b> 6.69340	<b>0.032</b> 0.00130	<b>0.012</b> 0.00050
<b>2.1</b> 0.079	<b>115.2</b> 4.54	<b>114.4</b> 4.51	<b>166.0</b> 6.54	<b>165.2</b> 6.51	<b>100.005</b> 3.93720	<b>99.995</b> 3.93680	<b>0.005</b> 0.00020	<b>0.013</b> 0.00050	<b>180.010</b> 7.08700	<b>180.000</b> 7.08660	<b>0.000</b> 0.00000	<b>0.020</b> 0.00080	<b>180.022</b> 7.08750	<b>180.012</b> 7.08710	<b>0.032</b> 0.00130	<b>0.012</b> 0.00050
<b>2.1</b> 0.079	<b>127.1</b> 5.01	<b>126.4</b> 4.98	<b>184.3</b> 7.26	<b>183.5</b> 7.23	<b>110.005</b> 4.33090	<b>109.995</b> 4.33050	<b>0.005</b> 0.00020	<b>0.013</b> 0.00050	<b>200.011</b> 7.87450	<b>200.000</b> 7.87400	<b>0.000</b> 0.00000	<b>0.022</b> 0.00090	<b>200.025</b> 7.87500	<b>200.015</b> 7.87460	<b>0.036</b> 0.00150	<b>0.015</b> 0.00060
<b>2.1</b> 0.079	<b>138.1</b> 5.44	<b>137.3</b> 5.41	<b>198.5</b> 7.82	<b>197.7</b> 7.79	<b>120.005</b> 4.72460	<b>119.995</b> 4.72420	<b>0.005</b> 0.00020	<b>0.013</b> 0.00050	<b>215.011</b> 8.46510	<b>215.000</b> 8.46460	<b>0.000</b> 0.00000	<b>0.022</b> 0.00090	<b>215.025</b> 8.46560	<b>215.015</b> 8.46520	<b>0.036</b> 0.00150	<b>0.015</b> 0.00060
<b>2.5</b> 0.098	<b>150.5</b> 5.93	<b>149.7</b> 5.90	<b>211.0</b> 8.31	<b>210.2</b> 8.28	<b>130.005</b> 5.11830	<b>129.995</b> 5.11790	<b>0.005</b> 0.00020	<b>0.015</b> 0.00060	<b>230.011</b> 9.05560	<b>230.000</b> 9.05510	<b>0.000</b> 0.00000	<b>0.022</b> 0.00090	<b>230.025</b> 9.05610	<b>230.015</b> 9.05570	<b>0.036</b> 0.00150	<b>0.015</b> 0.00060
<b>2.5</b> 0.098	<b>172.6</b> 6.80	<b>171.8</b> 6.77	<b>248.8</b> 9.80	<b>248.0</b> 9.77	<b>150.005</b> 5.90570	<b>149.995</b> 5.90530	<b>0.005</b> 0.00020	<b>0.015</b> 0.00060	<b>270.013</b> 10.63040	<b>270.000</b> 10.62990	<b>0.000</b> 0.00000	<b>0.026</b> 0.00100	<b>270.031</b> 10.63120	<b>270.018</b> 10.63070	<b>0.044</b> 0.00180	<b>0.018</b> 0.00080

**LIGHT ISO 02 SERIES**  
**2MV/MM200WI (7200C-...-P4/P4S)**  
**DUPLEX PERFORMANCE DATA**

Bearing Number	Preload			Axial Stiffness <sup>(1)</sup>				Radial Stiffness <sup>(1)</sup>				Spacer Offsets <sup>(1)</sup>		
	DUX X-light	DUL Light	DUM Med.	X-light	Light	Med.	Heavy	X-light	Light	Med.	Heavy	X-light to Light	Light to Med.	Med. to Heavy
	N lbs.	N lbs.	N lbs.	N/μm 10 <sup>6</sup> lbs./in.	N/μm 10 <sup>6</sup> lbs./in.	N/μm 10 <sup>6</sup> lbs./in.	N/μm 10 <sup>6</sup> lbs./in.	N/μm 10 <sup>6</sup> lbs./in.	N/μm 10 <sup>6</sup> lbs./in.	N/μm 10 <sup>6</sup> lbs./in.	N/μm 10 <sup>6</sup> lbs./in.	μm in.	μm in.	μm in.
2MV/MM200WICR	—	<b>20</b>	<b>90</b>	—	<b>18.54</b>	<b>33.06</b>	<b>42.85</b>	—	<b>85.88</b>	<b>136.07</b>	<b>162.13</b>	—	<b>10.41</b>	<b>7.11</b>
7200C-T-P4/P4S	—	5	20	—	0.106	0.189	0.245	—	0.491	0.778	0.927	—	0.00041	0.00028
2MV/MM201WICR	—	<b>20</b>	<b>90</b>	—	<b>19.24</b>	<b>34.11</b>	<b>44.07</b>	—	<b>96.02</b>	<b>153.56</b>	<b>183.30</b>	—	<b>9.91</b>	<b>6.86</b>
7201C-T-P4/P4S	—	5	20	—	0.110	0.195	0.252	—	0.549	0.878	1.048	—	0.00039	0.00027
2MV/MM202WICR	—	<b>20</b>	<b>90</b>	—	<b>20.64</b>	<b>36.20</b>	<b>49.67</b>	—	<b>102.67</b>	<b>164.93</b>	<b>205.51</b>	—	<b>9.40</b>	<b>8.38</b>
7202C-T-P4/P4S	—	5	20	—	0.118	0.207	0.284	—	0.587	0.943	1.175	—	0.00037	0.00033
2MV/MM203WICR	—	<b>40</b>	<b>130</b>	—	<b>25.54</b>	<b>41.10</b>	<b>63.84</b>	—	<b>137.12</b>	<b>197.46</b>	<b>263.05</b>	—	<b>10.67</b>	<b>15.24</b>
7203C-T-P4/P4S	—	10	30	—	0.146	0.235	0.365	—	0.784	1.129	1.504	—	0.00042	0.00060
2MV/MM204WICR	—	<b>70</b>	<b>180</b>	—	<b>30.08</b>	<b>46.17</b>	<b>64.36</b>	—	<b>168.43</b>	<b>232.97</b>	<b>289.81</b>	—	<b>11.68</b>	<b>12.95</b>
7204C-T-P4/P4S	—	15	40	—	0.172	0.264	0.368	—	0.963	1.332	1.657	—	0.00046	0.00051
2MV/MM205WICR	—	<b>90</b>	<b>220</b>	—	<b>37.60</b>	<b>56.49</b>	<b>74.86</b>	—	<b>209.53</b>	<b>283.16</b>	<b>340.88</b>	—	<b>11.43</b>	<b>10.92</b>
7205C-T-P4/P4S	—	20	50	—	0.215	0.323	0.428	—	1.198	1.619	1.949	—	0.00045	0.00043
2MV/MM206WICR	—	<b>90</b>	<b>220</b>	—	<b>38.30</b>	<b>56.49</b>	<b>87.10</b>	—	<b>222.47</b>	<b>303.10</b>	<b>405.77</b>	—	<b>11.18</b>	<b>18.54</b>
7206C-T-P4/P4S	—	20	50	—	0.219	0.323	0.498	—	1.272	1.733	2.320	—	0.00044	0.00073
2MV/MM207WICR	—	<b>130</b>	<b>400</b>	—	<b>47.22</b>	<b>75.91</b>	<b>104.42</b>	—	<b>269.35</b>	<b>388.10</b>	<b>478.70</b>	—	<b>17.27</b>	<b>16.76</b>
7207C-T-P4/P4S	—	30	90	—	0.270	0.434	0.597	—	1.540	2.219	2.737	—	0.00068	0.00066
2MV/MM208WICR	—	<b>130</b>	<b>440</b>	—	<b>45.30</b>	<b>75.73</b>	<b>105.46</b>	—	<b>261.65</b>	<b>392.65</b>	<b>489.20</b>	—	<b>20.57</b>	<b>19.56</b>
7208C-T-P4/P4S	—	30	100	—	0.259	0.433	0.603	—	1.496	2.245	2.797	—	0.00081	0.00077
2MV/MM209WICR	<b>110</b>	<b>180</b>	<b>560</b>	<b>46.52</b>	<b>56.14</b>	<b>91.82</b>	<b>128.20</b>	<b>271.28</b>	<b>322.87</b>	<b>472.58</b>	<b>588.36</b>	<b>5.08</b>	<b>20.32</b>	<b>20.32</b>
7209C-T-P4/P4S	25	40	125	0.266	0.321	0.525	0.733	1.549	1.846	2.702	3.364	0.00020	0.00080	0.00080
2MV/MM210WICR	<b>130</b>	<b>220</b>	<b>560</b>	<b>51.60</b>	<b>64.19</b>	<b>95.67</b>	<b>139.57</b>	<b>304.91</b>	<b>366.24</b>	<b>496.89</b>	<b>637.86</b>	<b>6.35</b>	<b>16.76</b>	<b>22.61</b>
7210C-T-P4/P4S	30	50	125	0.295	0.367	0.547	0.798	1.741	2.094	2.841	3.647	0.00025	0.00066	0.00089
2MV/MM211WICR	<b>160</b>	<b>220</b>	<b>780</b>	<b>54.22</b>	<b>63.31</b>	<b>109.49</b>	<b>153.74</b>	<b>335.53</b>	<b>382.86</b>	<b>582.42</b>	<b>724.61</b>	<b>4.83</b>	<b>25.65</b>	<b>23.62</b>
7211C-T-P4/P4S	35	50	175	0.310	0.362	0.626	0.879	1.916	2.189	3.330	4.143	0.00019	0.00101	0.00093
2MV/MM212WICR	<b>180</b>	<b>330</b>	<b>890</b>	<b>59.12</b>	<b>77.66</b>	<b>119.11</b>	<b>171.40</b>	<b>361.94</b>	<b>456.31</b>	<b>632.26</b>	<b>802.44</b>	<b>9.65</b>	<b>22.61</b>	<b>27.69</b>
7212C-T-P4/P4S	40	75	200	0.338	0.444	0.681	0.980	2.067	2.609	3.615	4.588	0.00038	0.00089	0.00109

<sup>(1)</sup>For DB or DF arrangements only. For other mounting arrangements, contact your Timken representative.

**MOUNTING ARRANGEMENTS**

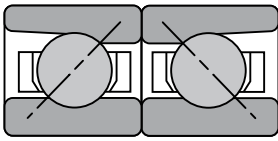

**Back-to-Back  
DB**

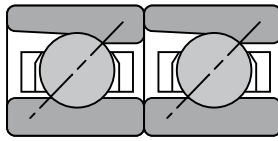

**Tandem  
DT**

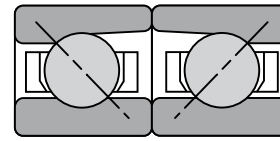

**Face-to-Face  
DF**

Bearing Number	Preload			Axial Stiffness <sup>(1)</sup>				Radial Stiffness <sup>(1)</sup>				Spacer Offsets <sup>(1)</sup>		
	DUX X-light	DUL Light	DUM Med.	X-light	Light	Med.	Heavy	X-light	Light	Med.	Heavy	X-light to Light	Light to Med.	Med. to Heavy
	<b>N</b> lbs.	<b>N</b> lbs.	<b>N</b> lbs.	<b>N/μm</b> 10 <sup>6</sup> lbs./in.	<b>N/μm</b> 10 <sup>6</sup> lbs./in.	<b>N/μm</b> 10 <sup>6</sup> lbs./in.	<b>N/μm</b> 10 <sup>6</sup> lbs./in.	<b>N/μm</b> 10 <sup>6</sup> lbs./in.	<b>N/μm</b> 10 <sup>6</sup> lbs./in.	<b>N/μm</b> 10 <sup>6</sup> lbs./in.	<b>N/μm</b> 10 <sup>6</sup> lbs./in.	<b>N/μm</b> 10 <sup>6</sup> lbs./in.	<b>μm</b> in.	<b>μm</b> in.
2MV/MM213WICR 7213C-T-P4/P4S	<b>200</b> 45	<b>440</b> 100	<b>1000</b> 225	<b>62.61</b> 0.358	<b>88.32</b> 0.505	<b>126.28</b> 0.722	<b>181.20</b> 1.036	<b>383.60</b> 2.191	<b>511.76</b> 2.926	<b>668.64</b> 3.823	<b>846.52</b> 4.840	<b>13.46</b> 0.00053	<b>20.83</b> 0.00082	<b>28.96</b> 0.00114
2MV/MM214WICR 7214C-T-P4/P4S	<b>220</b> 50	<b>440</b> 100	<b>1110</b> 250	<b>67.86</b> 0.388	<b>89.72</b> 0.513	<b>133.97</b> 0.766	<b>186.97</b> 1.069	<b>404.25</b> 2.308	<b>519.80</b> 2.972	<b>703.80</b> 4.024	<b>876.25</b> 5.010	<b>11.18</b> 0.00044	<b>23.88</b> 0.00094	<b>27.69</b> 0.00109
2MV/MM215WICR 7215C-T-P4/P4S	<b>240</b> 55	<b>560</b> 125	<b>1220</b> 275	<b>72.93</b> 0.417	<b>102.49</b> 0.586	<b>145.34</b> 0.831	<b>203.06</b> 1.161	<b>437.79</b> 2.500	<b>586.96</b> 3.356	<b>760.64</b> 4.349	<b>946.38</b> 5.411	<b>14.48</b> 0.00057	<b>21.59</b> 0.00085	<b>28.19</b> 0.00111
2MV/MM216WICR 7216C-T-P4/P4S	<b>270</b> 60	<b>670</b> 150	<b>1450</b> 325	<b>77.66</b> 0.444	<b>113.16</b> 0.647	<b>159.16</b> 0.910	<b>217.75</b> 1.245	<b>458.80</b> 2.620	<b>639.96</b> 3.659	<b>825.18</b> 4.718	<b>1014.59</b> 5.801	<b>17.02</b> 0.00067	<b>22.86</b> 0.00090	<b>28.45</b> 0.00112
2MV/MM217WICR 7217C-T-P4/P4S	<b>360</b> 65	<b>890</b> 175	<b>2000</b> 375	<b>86.75</b> 0.461	<b>126.10</b> 0.682	<b>179.97</b> 0.957	<b>250.98</b> 1.339	<b>480.97</b> 2.747	<b>693.68</b> 3.961	<b>891.34</b> 5.090	<b>1109.60</b> 6.336	<b>20.07</b> 0.00075	<b>28.96</b> 0.00098	<b>37.08</b> 0.00131
2MV/MM218WICR 7218C-T-P4/P4S	<b>330</b> 75	<b>780</b> 175	<b>1780</b> 400	<b>82.55</b> 0.472	<b>116.83</b> 0.668	<b>168.25</b> 0.962	<b>235.07</b> 1.344	<b>497.82</b> 2.843	<b>678.61</b> 3.880	<b>891.47</b> 5.097	<b>1109.92</b> 6.346	<b>18.03</b> 0.00071	<b>27.94</b> 0.00110	<b>35.31</b> 0.00139
2MV/MM219WICR 7219C-T-P4/P4S	<b>360</b> 80	<b>890</b> 200	<b>2000</b> 450	<b>86.75</b> 0.496	<b>126.10</b> 0.721	<b>179.97</b> 1.029	<b>250.98</b> 1.435	<b>517.46</b> 2.955	<b>726.88</b> 4.156	<b>932.74</b> 5.333	<b>1183.02</b> 6.764	<b>20.07</b> 0.00079	<b>28.96</b> 0.00114	<b>37.08</b> 0.00146
2MV/MM220WICR 7220C-T-P4/P4S	<b>380</b> 85	<b>1110</b> 250	<b>2220</b> 500	<b>88.85</b> 0.508	<b>137.65</b> 0.787	<b>187.14</b> 1.070	<b>261.30</b> 1.494	<b>531.57</b> 3.036	<b>795.80</b> 4.550	<b>1000.08</b> 5.718	<b>1245.99</b> 7.124	<b>25.91</b> 0.00102	<b>27.43</b> 0.00108	<b>39.62</b> 0.00156
2MV/MM222WICR 7222C-T-P4/P4S	<b>440</b> 100	<b>1330</b> 300	<b>2670</b> 600	<b>98.64</b> 0.564	<b>153.91</b> 0.880	<b>208.48</b> 1.192	<b>289.81</b> 1.657	<b>580.64</b> 3.316	<b>881.32</b> 5.039	<b>1108.17</b> 6.336	<b>1381.36</b> 7.898	<b>28.19</b> 0.00111	<b>29.46</b> 0.00116	<b>42.93</b> 0.00169
2MV/MM224WICR 7224C-T-P4/P4S	<b>490</b> 110	<b>1470</b> 330	<b>2940</b> 660	<b>102.84</b> 0.588	<b>158.81</b> 0.908	<b>215.65</b> 1.233	<b>300.13</b> 1.716	<b>610.16</b> 3.484	<b>926.97</b> 5.300	<b>1166.06</b> 6.667	<b>1453.59</b> 8.311	<b>29.46</b> 0.00116	<b>31.24</b> 0.00123	<b>45.47</b> 0.00179
2MV/MM226WICR 7226C-T-P4/P4S	<b>560</b> 125	<b>1650</b> 370	<b>3290</b> 740	<b>121.21</b> 0.693	<b>186.44</b> 1.066	<b>252.38</b> 1.443	<b>350.32</b> 2.003	<b>715.23</b> 4.084	<b>1089.45</b> 6.229	<b>1372.44</b> 7.847	<b>1712.80</b> 9.793	<b>27.94</b> 0.00110	<b>29.97</b> 0.00118	<b>43.69</b> 0.00172
2MV/MM230WICR 7230C-T-P4/P4S	<b>690</b> 155	<b>1890</b> 425	<b>3780</b> 850	<b>130.3</b> 0.745	<b>192.74</b> 1.102	<b>258.85</b> 1.480	<b>356.10</b> 2.036	<b>758.85</b> 4.333	<b>1136.85</b> 6.500	<b>1437.33</b> 8.218	<b>1797.97</b> 10.280	<b>29.46</b> 0.00116	<b>33.53</b> 0.00132	<b>49.28</b> 0.00194

**LIGHT ISO 02 SERIES**  
**3MV/MM200WI (7200E-...-P4/P4S)**  
**DUPLEX PERFORMANCE DATA**

Bearing Number	Preload				Axial Stiffness <sup>(1)</sup>			Radial Stiffness <sup>(1)</sup>			Spacer Offsets <sup>(1)</sup>		
	DUX X-light	DUL Light	DUM Med.	DUH Heavy	Light	Med.	Heavy	Light	Med.	Heavy	X-light to Light	Light to Med.	Med. to Heavy
	<b>N</b> lbs.	<b>N</b> lbs.	<b>N</b> lbs.	<b>N</b> lbs.	<b>N/μm</b> 10 <sup>6</sup> lbs./in.	<b>N/μm</b> 10 <sup>6</sup> lbs./in.	<b>N/μm</b> 10 <sup>6</sup> lbs./in.	<b>N/μm</b> 10 <sup>6</sup> lbs./in.	<b>N/μm</b> 10 <sup>6</sup> lbs./in.	<b>N/μm</b> 10 <sup>6</sup> lbs./in.	<b>N/μm</b> 10 <sup>6</sup> lbs./in.	<b>μm</b> in.	<b>μm</b> in.
3MV/MM200WICR	—	<b>40</b>	<b>130</b>	<b>270</b>	<b>39.35</b>	<b>59.99</b>	<b>79.75</b>	<b>84.65</b>	<b>121.38</b>	<b>150.94</b>	—	<b>7.11</b>	<b>7.62</b>
7200E-T-P4/P4S	—	10	30	60	0.225	0.343	0.456	0.484	0.694	0.863	—	0.00028	0.00030
3MV/MM201WICR	—	<b>40</b>	<b>130</b>	<b>270</b>	<b>44.77</b>	<b>67.51</b>	<b>88.85</b>	<b>94.10</b>	<b>135.90</b>	<b>169.48</b>	—	<b>6.35</b>	<b>6.86</b>
7201E-T-P4/P4S	—	10	30	60	0.256	0.386	0.508	0.538	0.777	0.969	—	0.00025	0.00027
3MV/MM202WICR	—	<b>70</b>	<b>180</b>	<b>360</b>	<b>55.44</b>	<b>80.45</b>	<b>106.51</b>	<b>115.96</b>	<b>160.21</b>	<b>199.39</b>	—	<b>6.60</b>	<b>6.60</b>
7202E-T-P4/P4S	—	15	40	80	0.317	0.460	0.609	0.663	0.916	1.140	—	0.00026	0.00026
3MV/MM203WICR	—	<b>90</b>	<b>330</b>	<b>440</b>	<b>63.84</b>	<b>105.99</b>	<b>119.28</b>	<b>132.92</b>	<b>204.46</b>	<b>223.87</b>	—	<b>11.43</b>	<b>4.06</b>
7203E-T-P4/P4S	—	20	75	100	0.365	0.606	0.682	0.760	1.169	1.280	—	0.00045	0.00016
3MV/MM204WICR	—	<b>130</b>	<b>360</b>	<b>560</b>	<b>75.21</b>	<b>109.66</b>	<b>131.35</b>	<b>159.51</b>	<b>220.02</b>	<b>253.26</b>	—	<b>9.65</b>	<b>6.60</b>
7204E-T-P4/P4S	—	30	80	125	0.430	0.627	0.751	0.912	1.258	1.448	—	0.00038	0.00026
3MV/MM205WICR	—	<b>160</b>	<b>400</b>	<b>670</b>	<b>89.20</b>	<b>128.20</b>	<b>157.76</b>	<b>189.59</b>	<b>258.50</b>	<b>303.98</b>	—	<b>8.89</b>	<b>7.37</b>
7205E-T-P4/P4S	—	35	90	150	0.510	0.733	0.902	1.084	1.478	1.738	—	0.00035	0.00029
3MV/MM206WICR	—	<b>220</b>	<b>560</b>	<b>890</b>	<b>106.16</b>	<b>150.76</b>	<b>182.42</b>	<b>227.02</b>	<b>306.77</b>	<b>356.10</b>	—	<b>10.41</b>	<b>7.87</b>
7206E-T-P4/P4S	—	50	125	200	0.607	0.862	1.043	1.298	1.754	2.036	—	0.00041	0.00031
3MV/MM207WICR	<b>130</b>	<b>310</b>	<b>780</b>	<b>1330</b>	<b>126.45</b>	<b>179.62</b>	<b>223.52</b>	<b>267.42</b>	<b>360.99</b>	<b>428.33</b>	<b>6.86</b>	<b>12.19</b>	<b>12.19</b>
7207E-T-P4/P4S	30	70	175	300	0.723	1.027	1.278	1.529	2.064	2.449	0.00027	0.00048	0.00048
3MV/MM208WICR	<b>160</b>	<b>360</b>	<b>890</b>	<b>1330</b>	<b>132.57</b>	<b>187.84</b>	<b>220.90</b>	<b>275.64</b>	<b>372.71</b>	<b>423.96</b>	<b>7.11</b>	<b>13.21</b>	<b>8.64</b>
7208E-T-P4/P4S	35	80	200	300	0.758	1.074	1.263	1.576	2.131	2.424	0.00028	0.00052	0.00034
3MV/MM209WICR	<b>180</b>	<b>440</b>	<b>1110</b>	<b>1780</b>	<b>159.86</b>	<b>226.85</b>	<b>274.24</b>	<b>332.14</b>	<b>448.44</b>	<b>520.50</b>	<b>7.87</b>	<b>13.72</b>	<b>10.67</b>
7209E-T-P4/P4S	40	100	250	400	0.914	1.297	1.568	1.899	2.564	2.976	0.00031	0.00054	0.00042
3MV/MM210WICR	<b>200</b>	<b>490</b>	<b>1220</b>	<b>2000</b>	<b>173.68</b>	<b>246.43</b>	<b>300.65</b>	<b>360.12</b>	<b>486.22</b>	<b>568.25</b>	<b>7.62</b>	<b>13.97</b>	<b>11.43</b>
7210E-T-P4/P4S	45	110	275	450	0.993	1.409	1.719	2.059	2.780	3.249	0.00030	0.00055	0.00045
3MV/MM211WICR	<b>220</b>	<b>620</b>	<b>1560</b>	<b>2450</b>	<b>193.61</b>	<b>274.94</b>	<b>330.21</b>	<b>407.34</b>	<b>549.71</b>	<b>634.36</b>	<b>9.65</b>	<b>15.75</b>	<b>11.68</b>
7211E-T-P4/P4S	50	140	350	550	1.107	1.572	1.888	2.329	3.143	3.627	0.00038	0.00062	0.00046
3MV/MM212WICR	<b>240</b>	<b>760</b>	<b>1890</b>	<b>2890</b>	<b>213.73</b>	<b>303.63</b>	<b>360.47</b>	<b>450.02</b>	<b>607.43</b>	<b>695.05</b>	<b>11.18</b>	<b>17.53</b>	<b>11.94</b>
7212E-T-P4/P4S	55	170	425	650	1.222	1.736	2.061	2.573	3.473	3.974	0.00044	0.00069	0.00047
3MV/MM213WICR	<b>270</b>	<b>850</b>	<b>2110</b>	<b>3340</b>	<b>225.62</b>	<b>320.42</b>	<b>385.65</b>	<b>474.50</b>	<b>640.48</b>	<b>740.18</b>	<b>11.94</b>	<b>18.54</b>	<b>13.72</b>

<sup>(1)</sup>For DB or DF arrangements only. For other mounting arrangements, contact your Timken representative.



**MOUNTING ARRANGEMENTS**

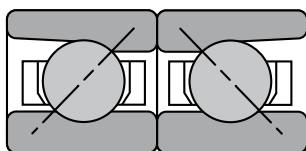

**Back-to-Back  
DB**

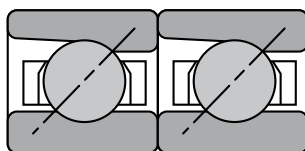

**Tandem  
DT**

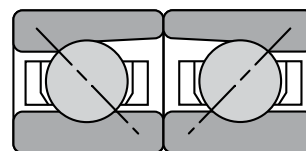

**Face-to-Face  
DF**

Bearing Number	Preload				Axial Stiffness <sup>(1)</sup>			Radial Stiffness <sup>(1)</sup>			Spacer Offsets <sup>(1)</sup>		
	DUX X-light	DUL Light	DUM Med.	DUH Heavy	Light	Med.	Heavy	Light	Med.	Heavy	X-light to Light	Light to Med.	Med. to Heavy
	<b>N</b> lbs.	<b>N</b> lbs.	<b>N</b> lbs.	<b>N</b> lbs.	<b>N/μm</b> 10 <sup>6</sup> lbs./in.	<b>N/μm</b> 10 <sup>6</sup> lbs./in.	<b>N/μm</b> 10 <sup>6</sup> lbs./in.	<b>N/μm</b> 10 <sup>6</sup> lbs./in.	<b>N/μm</b> 10 <sup>6</sup> lbs./in.	<b>N/μm</b> 10 <sup>6</sup> lbs./in.	<b>μm</b> in.	<b>μm</b> in.	<b>μm</b> in.
7213E-T-P4/P4S	60	190	475	750	1.290	1.832	2.205	2.713	3.662	4.232	0.00047	0.00073	0.00054
3MV/MM214WICR	<b>290</b>	<b>890</b>	<b>2220</b>	<b>3560</b>	<b>231.39</b>	<b>328.46</b>	<b>397.37</b>	<b>492.87</b>	<b>665.67</b>	<b>772.53</b>	<b>12.19</b>	<b>19.05</b>	<b>14.73</b>
7214E-T-P4/P4S	65	200	500	800	1.323	1.878	2.272	2.818	3.806	4.417	0.00048	0.00075	0.00058
3MV/MM215WICR	<b>360</b>	<b>980</b>	<b>2450</b>	<b>3780</b>	<b>250.28</b>	<b>355.75</b>	<b>424.13</b>	<b>532.75</b>	<b>719.19</b>	<b>825.53</b>	<b>11.68</b>	<b>19.30</b>	<b>13.72</b>
7215E-T-P4/P4S	80	220	550	850	1.431	2.034	2.425	3.046	4.112	4.720	0.00046	0.00076	0.00054
3MV/MM216WICR	<b>400</b>	<b>1110</b>	<b>2780</b>	<b>4450</b>	<b>269.87</b>	<b>383.03</b>	<b>462.79</b>	<b>570.35</b>	<b>770.61</b>	<b>894.61</b>	<b>12.45</b>	<b>20.32</b>	<b>15.75</b>
7216E-T-P4/P4S	90	250	625	1000	1.543	2.190	2.646	3.261	4.406	5.115	0.00049	0.00080	0.00062
3MV/MM217WICR	<b>440</b>	<b>1200</b>	<b>3000</b>	<b>4890</b>	<b>280.36</b>	<b>397.37</b>	<b>483.42</b>	<b>600.43</b>	<b>812.41</b>	<b>949.18</b>	<b>12.45</b>	<b>21.08</b>	<b>17.02</b>
7217E-T-P4/P4S	100	270	675	1100	1.603	2.272	2.764	3.433	4.645	5.427	0.00049	0.00083	0.00067
3MV/MM218WICR	<b>490</b>	<b>1330</b>	<b>3110</b>	<b>5560</b>	<b>286.14</b>	<b>394.75</b>	<b>498.12</b>	<b>608.83</b>	<b>805.06</b>	<b>968.42</b>	<b>13.72</b>	<b>20.83</b>	<b>21.84</b>
7218E-T-P4/P4S	110	300	700	1250	1.636	2.257	2.848	3.481	4.603	5.537	0.00054	0.00082	0.00086
3MV/MM219WICR	<b>560</b>	<b>1560</b>	<b>3110</b>	<b>6230</b>	<b>310.27</b>	<b>402.97</b>	<b>531.00</b>	<b>655.70</b>	<b>824.65</b>	<b>1029.29</b>	<b>15.24</b>	<b>17.27</b>	<b>26.67</b>
7219E-T-P4/P4S	125	350	700	1400	1.774	2.304	3.036	3.749	4.715	5.885	0.00060	0.00068	0.00105
3MV/MM220WICR	<b>600</b>	<b>1730</b>	<b>3470</b>	<b>6940</b>	<b>328.29</b>	<b>426.41</b>	<b>561.60</b>	<b>694.18</b>	<b>873.45</b>	<b>1090.50</b>	<b>16.26</b>	<b>18.29</b>	<b>27.94</b>
7220E-T-P4/P4S	135	390	780	1560	1.877	2.438	3.211	3.969	4.994	6.235	0.00064	0.00072	0.00110
3MV/MM222WICR	<b>690</b>	<b>2050</b>	<b>4082</b>	<b>8180</b>	<b>359.94</b>	<b>466.81</b>	<b>613.90</b>	<b>762.39</b>	<b>960.03</b>	<b>1199.46</b>	<b>17.78</b>	<b>19.81</b>	<b>30.23</b>
7222E-T-P4/P4S	155	460	920	1840	2.058	2.669	3.510	4.359	5.489	6.858	0.00070	0.00078	0.00119
3MV/MM224WICR	<b>820</b>	<b>2250</b>	<b>4480</b>	<b>8980</b>	<b>377.78</b>	<b>490.07</b>	<b>643.98</b>	<b>805.76</b>	<b>1014.77</b>	<b>1267.85</b>	<b>17.53</b>	<b>20.57</b>	<b>31.50</b>
7224E-T-P4/P4S	185	505	1010	2020	2.160	2.802	3.682	4.607	5.802	7.249	0.00069	0.00081	0.00124
3MV/MM226WICR	<b>980</b>	<b>2560</b>	<b>5120</b>	<b>10230</b>	<b>448.09</b>	<b>580.49</b>	<b>761.86</b>	<b>954.08</b>	<b>1190.72</b>	<b>1503.97</b>	<b>16.51</b>	<b>19.81</b>	<b>30.48</b>
7226E-T-P4/P4S	220	575	1150	2300	2.562	3.319	4.356	5.455	6.808	8.599	0.00065	0.00078	0.00120
3MV/MM230WICR	<b>1290</b>	<b>3110</b>	<b>6230</b>	<b>12450</b>	<b>473.63</b>	<b>612.32</b>	<b>801.04</b>	<b>1009.87</b>	<b>1276.25</b>	<b>1598.24</b>	<b>17.53</b>	<b>22.86</b>	<b>35.05</b>
7230E-T-P4/P4S	290	700	1400	2800	2.708	3.501	4.580	5.774	7.297	9.138	0.00069	0.0009	0.00138

**LIGHT ISO 02 SERIES**  
**2MV/MM200WI (7200C-...-P4/P4S)**  
**SPEED CAPABILITY DATA**

Fafnir Bearing Number	Timken ISO Bearing Number	Grease Capacity <sup>(1)</sup>				Operating Speeds <sup>(4)</sup> (DB Mounting) <sup>(5)</sup>					
		Low Speed <sup>(2)</sup>		High Speed <sup>(3)</sup>		Grease			Oil		
		25%	40%	10%	15%	DUL	DUM	DUH	DUL	DUM	DUH
		grams	grams	grams	grams	RPM	RPM	RPM	RPM	RPM	RPM
2MV/MM200WICR	7200C-T-P4/P4S	0.30	0.50	0.14	0.20	50200	37700	25100	85300	64100	42700
2MV/MM201WICR	7201C-T-P4/P4S	0.40	0.60	0.17	0.25	45400	34000	22200	79100	57800	39400
2MV/MM202WICR	7202C-T-P4/P4S	0.50	0.80	0.22	0.32	38200	28700	19100	66300	48800	33200
2MV/MM203WICR	7203C-T-P4/P4S	0.70	1.10	0.30	0.45	33500	25100	16500	58100	42700	29100
2MV/MM204WICR	7204C-T-P4/P4S	1.10	1.70	0.48	0.72	28600	21400	14300	48600	36400	24300
2MV/MM205WICR	7205C-T-P4/P4S	1.30	2.10	0.59	0.88	23800	17900	11900	40500	30400	20200
2MV/MM206WICR	7206C-T-P4/P4S	2.00	3.10	0.87	1.31	20000	15100	10000	34200	25600	17000
2MV/MM207WICR	7207C-T-P4/P4S	2.70	4.40	1.22	1.82	17300	13 000	8600	29400	22000	14600
2MV/MM208WICR	7208C-T-P4/P4S	3.70	6.00	1.66	2.49	15400	11600	7700	26200	19700	13100
2MV/MM209WICR	7209C-T-P4/P4S	4.20	6.60	1.85	2.77	14000	10500	7000	22800	17900	11900
2MV/MM210WICR	7210C-T-P4/P4S	4.80	7.60	2.15	3.20	12500	9600	6400	21800	16300	10900
2MV/MM211WICR	7211C-T-P4/P4S	6.10	9.70	2.70	4.10	11600	8700	5800	19700	14800	9900
2MV/MM212WICR	7212C-T-P4/P4S	7.50	12.00	3.35	5.00	10600	7920	5300	18000	13500	9000
2MV/MM213WICR	7213C-T-P4/P4S	9.20	14.60	4.05	6.10	9700	7260	4800	16500	12300	8200
2MV/MM214WICR	7214C-T-P4/P4S	10.60	16.90	4.70	7.00	9100	6840	4600	15500	11600	7800
2MV/MM215WICR	7215C-T-P4/P4S	11.60	18.60	5.15	7.80	8600	6480	4300	14600	11020	7300
2MV/MM216WICR	7216C-T-P4/P4S	13.70	22.00	6.10	9.20	8100	6060	4000	13800	10300	6800
2MV/MM217WICR	7217C-T-P4/P4S	16.90	27.10	7.55	11.30	7500	5640	3800	12800	9590	6500
2MV/MM218WICR	7218C-T-P4/P4S	21.50	34.40	9.55	14.40	7100	5340	3600	12100	9080	6100
2MV/MM219WICR	7219C-T-P4/P4S	25.80	41.40	11.50	17.30	6700	5040	3400	11400	8570	5800
2MV/MM220WICR	7220C-T-P4/P4S	30.70	49.10	13.65	20.50	6400	4800	3200	10900	8160	5400
2MV/MM222WICR	7222C-T-P4/P4S	42.30	67.60	18.80	28.20	5800	4320	2900	9900	7340	4900
2MV/MM224WICR	7224C-T-P4/P4S	51.40	82.30	22.90	34.30	5400	4020	2700	9200	6830	4600
2MV/MM226WICR	7226C-T-P4/P4S	50.80	81.30	22.60	33.90	4900	3660	2400	8300	6220	4100
2MV/MM230WICR	7230C-T-P4/P4S	82.40	131.90	36.70	55.00	4200	3180	2160	7100	5410	3600

<sup>(1)</sup>Fill weights based on specific gravity of 0.99.

<sup>(2)</sup>Low speed <500000 dN.

<sup>(3)</sup>High speed > 500000 dN.

<sup>(4)</sup>For ceramic ball complements, use 120 percent of speeds shown.

<sup>(5)</sup>For other mounting arrangement configurations, refer to the engineering section on permissible speed calculation methods.

**LIGHT ISO 02 SERIES**  
**3MV/MM200WI (7200E-...-P4/P4S)**  
**SPEED CAPABILITY DATA**

Fafnir Bearing Number	Timken ISO Bearing Number	Grease Capacity <sup>(1)</sup>				Operating Speeds <sup>(4)</sup> (DB Mounting) <sup>(5)</sup>					
		Low Speed <sup>(2)</sup>		High Speed <sup>(3)</sup>		Grease			Oil		
		25%	40%	10%	15%	DUL	DUM	DUH	DUL	DUM	DUH
		grams	grams	grams	grams	RPM	RPM	RPM	RPM	RPM	RPM
3MV/MM200WICR	7200E-T-P4/P4S	0.30	0.50	0.14	0.20	45180	33930	22590	76770	57690	38430
3MV/MM201WICR	7201E-T-P4/P4S	0.40	0.60	0.17	0.25	40860	30600	19980	71190	52020	35460
3MV/MM202WICR	7202E-T-P4/P4S	0.50	0.80	0.22	0.32	34380	25830	17190	59670	43920	29880
3MV/MM203WICR	7203E-T-P4/P4S	0.70	1.10	0.30	0.45	30150	22590	14850	52290	38430	26190
3MV/MM204WICR	7204E-T-P4/P4S	1.10	1.70	0.48	0.72	25740	19260	12870	43740	32760	21870
3MV/MM205WICR	7205E-T-P4/P4S	1.30	2.10	0.59	0.88	21420	16110	10710	36450	27360	18180
3MV/MM206WICR	7206E-T-P4/P4S	2.00	3.10	0.87	1.31	18000	13590	9000	30780	23040	15300
3MV/MM207WICR	7207E-T-P4/P4S	2.70	4.40	1.22	1.82	15570	11700	7740	26460	19800	13140
3MV/MM208WICR	7208E-T-P4/P4S	3.70	6.00	1.66	2.49	13860	10440	6930	23580	17730	11790
3MV/MM209WICR	7209E-T-P4/P4S	4.20	6.60	1.85	2.77	12600	9450	6300	20520	16110	10710
3MV/MM210WICR	7210E-T-P4/P4S	4.80	7.60	2.15	3.20	11250	8640	5760	19620	14670	9810
3MV/MM211WICR	7211E-T-P4/P4S	6.10	9.70	2.70	4.10	10440	7830	5220	17730	13320	8910
3MV/MM212WICR	7212E-T-P4/P4S	7.50	12.00	3.35	5.00	9540	7128	4770	16200	12150	8100
3MV/MM213WICR	7213E-T-P4/P4S	9.20	14.60	4.05	6.10	8730	6534	4320	14850	11070	7380
3MV/MM214WICR	7214E-T-P4/P4S	10.60	16.90	4.70	7.00	8190	6156	4140	13950	10440	7020
3MV/MM215WICR	7215E-T-P4/P4S	11.60	18.60	5.15	7.80	7740	5832	3870	13140	9918	6570
3MV/MM216WICR	7216E-T-P4/P4S	13.70	22.00	6.10	9.20	7290	5454	3600	12420	9270	6120
3MV/MM217WICR	7217E-T-P4/P4S	16.90	27.10	7.55	11.30	6750	5076	3420	11520	8631	5850
3MV/MM218WICR	7218E-T-P4/P4S	21.50	34.40	9.55	14.40	6390	4806	3240	10890	8172	5490
3MV/MM219WICR	7219E-T-P4/P4S	25.80	41.40	11.50	17.30	6030	4536	3060	10260	7713	5220
3MV/MM220WICR	7220E-T-P4/P4S	30.70	49.10	13.65	20.50	5760	4320	2880	9810	7344	4860
3MV/MM222WICR	7222E-T-P4/P4S	42.30	67.60	18.80	28.20	5220	3888	2610	8910	6606	4410
3MV/MM224WICR	7224E-T-P4/P4S	51.40	82.30	22.90	34.30	4860	3618	2430	8280	6147	4140
3MV/MM226WICR	7226E-T-P4/P4S	50.80	81.30	22.60	33.90	4410	3294	2160	7470	5598	3690
3MV/MM230WICR	7230E-T-P4/P4S	82.40	131.90	36.70	55.00	3780	2862	1944	6390	4869	3240

<sup>(1)</sup>Fill weights based on specific gravity of 0.99.

<sup>(2)</sup>Low speed <500000 dN.

<sup>(3)</sup>High speed > 500000 dN.

<sup>(4)</sup>For ceramic ball complements, use 120 percent of speeds shown.

<sup>(5)</sup>For other mounting arrangement configurations, refer to the engineering section on permissible speed calculation methods.

**ULTRA-LIGHT ISO 02 SERIES**

**MM200K (6200-...-P4S)**

**SUPER PRECISION MMV**

Running accuracy and performance meet ABEC 9 (ISO P2) levels. Other features conform to ABEC 7 (ISO P4) requirements.

**DEEP-GROOVE (CONRAD) CONSTRUCTION**

- Incorporates high shoulder on both inner and outer rings.
- Balls separated by two-piece and piloted cage.

Bearing Number	d Bore	D O.D.	C Width <sup>(1)</sup>	Ball Qty. x Dia.	Bearing Wt.	Load Ratings						r Rad. <sup>(2)</sup>
						Steel Ball			Ceramic Ball			
						C <sub>0</sub> Static	C <sub>e</sub> Dynamic	Speed Rating <sup>(Ng)</sup>	C <sub>0</sub> Static	C <sub>e</sub> Dynamic	Speed Rating <sup>(Ng)</sup>	
mm in.	mm in.	mm in.	mm in.	kg lbs.	N lbs.	N lbs.	RPM	N lbs.	N lbs.	RPM	mm in.	
MM201K 6201	12 0.4724	32 1.2598	10 0.3940	7 x 5.95 7 x 1/4	0.035 0.08	3000 680	7550 1700	52200 52200	2710 610	7550 1700	62600 62600	0.6 0.024
MM202K 6202	15 0.5906	35 1.3780	11 0.4331	8 x 5.95 8 x 1/4	0.043 0.09	3700 830	8450 1900	44000 44000	3290 740	8450 1900	52800 52800	0.6 0.024
MM203K 6203	17 0.6693	40 1.5748	12 0.4724	8 x 6.75 8 x 1/4	0.062 0.14	4700 1060	10600 2380	38500 38500	4230 950	10600 2380	46200 46200	0.6 0.024
MM204K 6204	20 0.7874	47 1.8504	14 0.5512	8 x 7.94 8 x 5/16	0.100 0.22	6500 1460	14200 3190	32800 32800	5860 1320	14200 3190	39400 39400	1.0 0.039
MM205K 6205	25 0.9843	52 2.0472	15 0.5906	9 x 7.94 9 x 5/16	0.122 0.27	7800 1760	15500 3490	27400 27400	6980 1570	15500 3490	32900 32900	1.0 0.039
MM206K 6206	30 1.1811	62 2.4409	16 0.6299	9 x 9.53 9 x 3/8	0.185 0.41	11300 2550	21600 4850	23000 23000	10000 2.25	21600 4850	27600 27600	1.0 0.039
MM207K 6207	35 1.3780	72 2.8346	17 0.6693	9 x 11.11 9 x 7/16	0.267 0.59	15300 3450	28500 6400	19800 19800	13600 3060	28500 6400	23800 23800	1.0 0.039
MM208K 6208	40 1.5748	80 3.1496	18 0.7087	9 x 12.70 9 x 1/2	0.337 0.74	20000 4500	36200 8130	17700 17700	17700 3970	36200 8130	21200 21200	1.0 0.039
MM209K 6209	45 1.7717	85 3.3465	19 0.7480	9 x 12.70 9 x 1/2	0.377 0.83	20200 4550	36300 8160	16000 16000	18200 4090	36300 8160	19200 19200	1.0 0.039
MM210K 6210	50 1.9685	90 3.5433	20 0.7874	10 x 12.70 10 x 1/2	0.425 0.94	23100 5200	38900 8740	14600 14600	20600 4640	38900 8740	17500 17500	1.0 0.039
MM211K 6211	55 2.1654	100 3.9370	21 0.8268	10 x 14.29 10 x 9/16	0.564 1.24	29100 6550	48100 10800	13300 13300	26000 5850	48100 10800	16000 16000	1.5 0.059
MM212K 6212	60 2.3622	110 4.3307	22 0.8661	10 x 15.88 10 x 5/8	0.727 1.60	36300 8150	58200 13100	12100 12100	32000 7190	58200 13100	14500 14500	1.5 0.059
MM213K 6213	65 2.5591	120 4.7244	23 0.9055	10 x 16.67 10 x 21/32	0.928 2.05	40000 9000	63400 14300	11100 11100	35600 8000	63400 14300	13300 13300	1.5 0.059
MM214K 6214	70 2.7559	125 4.9213	24 0.9449	10 x 17.46 10 x 11/16	0.994 2.19	43600 9800	69000 15500	10500 10500	39200 8800	69000 15500	12600 12600	1.5 0.059
MM215K 6215	75 2.9528	130 5.1181	25 0.9843	10 x 17.46 10 x 11/16	1.074 2.37	44500 10000	68900 15500	9900 9900	39900 8960	68900 15500	11900 11900	1.5 0.059
MM216K 6216	80 3.1496	140 5.5118	26 1.0236	10 x 19.05 10 x 3/4	1.317 2.90	53400 12000	80600 18100	9200 9200	47200 10600	80600 18100	11000 11000	2.0 0.079

<sup>(Ng)</sup>For a single, grease-lubricated, spring-preloaded bearing. This value to be used in permissible operating speed (Sp) calculation.

<sup>(1)</sup>Width tolerance of preloaded bearing set +0.000/-0.254 mm (+0.0000/-0.0100 in.).

<sup>(2)</sup>ABMA STD 20 (ras max).

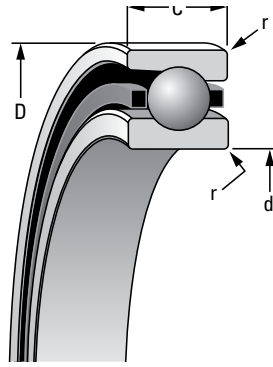

Suggested Shoulder Diameters				Shaft Diameter		Mounting Fits		Fixed				Floating			
Shaft		Housing						Housing Bore (Stationary)		Mounting Fits		Housing Bore (Stationary)		Mounting Fits	
Max.	Min.	Max.	Min.	Max.	Min.	Loose	Tight	Max.	Min.	Tight	Loose	Max.	Min.	Loose	Loose
mm in.	mm in.	mm in.	mm in.	mm in.	mm in.	mm in.	mm in.	mm in.	mm in.	mm in.	mm in.	mm in.	mm in.	mm in.	mm in.
16.6	16.4	28.1	27.8	12.000	11.995	0.005	0.004	32.005	32.000	0.000	0.011	32.010	32.005	0.016	0.005
0.66	0.65	1.11	1.10	0.47240	0.47220	0.00020	0.00015	1.26000	1.25980	0.00000	0.00045	1.26020	1.26000	0.00070	0.00020
19.2	18.9	31.1	30.9	15.000	14.995	0.005	0.004	35.006	35.000	0.000	0.012	35.010	35.005	0.016	0.005
0.76	0.75	1.23	1.22	0.59060	0.59040	0.00020	0.00015	1.37830	1.37800	0.00000	0.00050	1.37840	1.37820	0.00070	0.00020
21.7	21.5	35.7	35.4	17.000	16.995	0.005	0.004	40.006	40.000	0.000	0.012	40.010	40.005	0.016	0.005
0.86	0.85	1.41	1.40	0.66930	0.66910	0.00020	0.00015	1.57510	1.57480	0.00000	0.00050	1.57520	1.57500	0.00070	0.00020
26.0	25.8	41.5	41.3	20.000	19.995	0.005	0.005	47.006	47.000	0.000	0.012	47.012	47.007	0.018	0.007
1.03	1.02	1.64	1.63	0.78740	0.78720	0.00020	0.00020	1.85070	1.85040	0.00000	0.00050	1.85090	1.85070	0.00080	0.00030
31.1	30.9	47.1	46.9	25.000	24.995	0.005	0.005	52.006	52.000	0.000	0.013	52.012	52.007	0.019	0.007
1.23	1.22	1.86	1.85	0.98430	0.98410	0.00020	0.00020	2.04750	2.04720	0.00000	0.00055	2.04770	2.04750	0.00080	0.00030
36.7	36.5	56.0	55.8	30.000	29.995	0.005	0.005	62.008	62.000	0.000	0.015	62.012	62.007	0.019	0.007
1.45	1.44	2.21	2.20	1.18110	1.18090	0.00020	0.00020	2.44120	2.44090	0.00000	0.00060	2.44140	2.44120	0.00080	0.00030
42.7	42.2	65.3	64.8	35.000	34.995	0.005	0.006	72.008	72.000	0.000	0.015	72.011	72.007	0.019	0.007
1.68	1.66	2.57	2.55	1.37800	1.37780	0.00020	0.00025	2.83490	2.83460	0.00000	0.00060	2.83510	2.83490	0.00080	0.00030
47.8	47.2	73.2	72.6	40.000	39.995	0.005	0.006	80.008	80.000	0.000	0.015	80.012	80.008	0.020	0.008
1.88	1.86	2.88	2.86	1.57480	1.57460	0.00020	0.00025	3.14990	3.14960	0.00000	0.00060	3.15010	3.14990	0.00080	0.00030
52.8	52.3	78.2	77.7	45.000	44.995	0.005	0.006	85.008	85.000	0.000	0.016	85.016	85.009	0.024	0.009
2.08	2.06	3.08	3.06	1.77170	1.77150	0.00020	0.00025	3.34680	3.34650	0.00000	0.00060	3.34710	3.34680	0.00090	0.00030
57.9	57.4	83.3	82.8	50.000	49.995	0.005	0.006	90.008	90.000	0.000	0.016	90.015	90.007	0.023	0.007
2.28	2.26	3.28	3.26	1.96850	1.96830	0.00020	0.00025	3.54360	3.54330	0.00000	0.00060	3.54390	3.54360	0.00090	0.00030
63.8	63.3	92.2	91.7	55.000	54.995	0.005	0.007	100.008	100.000	0.000	0.016	100.018	100.010	0.025	0.010
2.51	2.49	3.63	3.61	2.16540	2.16520	0.00020	0.00030	3.93730	3.93700	0.00000	0.00060	3.93770	3.93740	0.00100	0.00040
69.9	69.3	101.4	100.8	60.000	59.995	0.005	0.007	110.008	110.000	0.000	0.016	110.018	110.010	0.025	0.010
2.75	2.73	3.99	3.97	2.36220	2.36200	0.00020	0.00030	4.33100	4.33070	0.00000	0.00060	4.33140	4.33110	0.00100	0.00040
76.2	75.7	109.7	109.2	65.000	64.995	0.005	0.007	120.008	120.000	0.000	0.016	120.018	120.010	0.025	0.010
3.00	2.98	4.32	4.30	2.55910	2.55890	0.00020	0.00030	4.72470	4.72440	0.00000	0.00060	4.72510	4.72480	0.00100	0.00040
80.8	80.3	115.8	115.3	70.000	69.995	0.005	0.007	125.008	125.000	0.000	0.017	125.021	125.011	0.030	0.011
3.18	3.16	4.56	4.54	2.75590	2.75570	0.00020	0.00030	4.92160	4.92130	0.00000	0.00070	4.92210	4.92170	0.00120	0.00040
86.0	85.2	120.8	120.0	75.005	74.995	0.005	0.012	130.009	130.000	0.000	0.018	130.020	130.010	0.029	0.010
3.39	3.36	4.76	4.73	2.95300	2.95260	0.00020	0.00050	5.11850	5.11810	0.00000	0.00070	5.11890	5.11850	0.00110	0.00040
91.3	90.6	129.9	129.2	80.005	79.995	0.005	0.012	140.009	140.000	0.000	0.018	140.020	140.010	0.029	0.010
3.60	3.57	5.12	5.09	3.14980	3.14940	0.00020	0.00050	5.51220	5.51180	0.00000	0.00070	5.51260	5.51220	0.00110	0.00040

**MEDIUM ISO 03 SERIES**  
**2(3)MM300WI (7300C(E)-...-P4S)**  
**SUPER PRECISION MMV**

Running accuracy and performance meet ABEC 9 (ISO P2) levels.  
 Other features conform to ABEC 7 (ISO P4) requirements.

**WI CONSTRUCTION**

- Incorporates low shoulder on non-thrust side of outer rings.
- Balls separated by one-piece cage piloted against a ground thrust shoulder land of the outer ring.

Bearing Number 15° C/2 <sup>(3)</sup> or 25° E/3 <sup>(4)</sup>	d Bore	D O.D.	C Width <sup>(1)</sup>	Ball Qty. x Dia.	Bearing Wt.	15° (C/2) Load Ratings						25° (E/3) Load Ratings					
						Steel Ball			Ceramic Ball			Steel Ball			Ceramic Ball		
						C <sub>0</sub> Static	C <sub>e</sub> Dynamic	Speed Rating <sup>(N<sub>g</sub>)</sup>	C <sub>0</sub> Static	C <sub>e</sub> Dynamic	Speed Rating <sup>(N<sub>g</sub>)</sup>	C <sub>0</sub> Static	C <sub>e</sub> Dynamic	Speed Rating <sup>(N<sub>g</sub>)</sup>	C <sub>0</sub> Static	C <sub>e</sub> Dynamic	Speed Rating <sup>(N<sub>g</sub>)</sup>
mm in.	mm in.	mm in.	mm in.	kg lbs.	N lbs.	N lbs.	RPM	N lbs.	N lbs.	RPM	N lbs.	N lbs.	RPM	N lbs.	N lbs.	RPM	
301WI	<b>12</b>	<b>37</b>	<b>12</b>	<b>8 x 7.14</b>	<b>0.061</b>	<b>4700</b>	<b>11000</b>	<b>47600</b>	<b>4230</b>	<b>11000</b>	<b>57100</b>	<b>4600</b>	<b>10900</b>	<b>42800</b>	<b>4060</b>	<b>10900</b>	<b>51400</b>
7301	0.4724	1.4567	0.4724	8 x 7/32	0.13	1060	2450	47600	950	2450	57100	1040	2450	42800	920	2450	51400
302WI	<b>15</b>	<b>42</b>	<b>13</b>	<b>10 x 6.75</b>	<b>0.087</b>	<b>5810</b>	<b>12000</b>	<b>38100</b>	<b>5170</b>	<b>12900</b>	<b>45700</b>	<b>5600</b>	<b>11600</b>	<b>34300</b>	<b>5000</b>	<b>11600</b>	<b>41200</b>
7302	0.5906	1.6535	0.5118	10 x 17/64	0.19	1320	2700	38100	1160	2700	45700	1270	2600	34300	1120	2600	41200
303WI	<b>17</b>	<b>47</b>	<b>14</b>	<b>7 x 9.53</b>	<b>0.104</b>	<b>7280</b>	<b>16900</b>	<b>36800</b>	<b>6480</b>	<b>16900</b>	<b>44200</b>	<b>7100</b>	<b>16400</b>	<b>33100</b>	<b>6300</b>	<b>16400</b>	<b>39700</b>
7303	0.6693	1.8504	0.5512	7 x 3/8	0.23	1630	3790	36800	1460	3790	44100	1600	3690	33100	1420	3690	39700
304WI	<b>20</b>	<b>52</b>	<b>15</b>	<b>8 x 10.32</b>	<b>0.137</b>	<b>10000</b>	<b>21500</b>	<b>32200</b>	<b>8900</b>	<b>21500</b>	<b>38600</b>	<b>9650</b>	<b>20900</b>	<b>29000</b>	<b>8590</b>	<b>20900</b>	<b>34800</b>
7304	0.7874	2.0472	0.5906	8 x 13/32	0.30	2200	4840	32200	2000	4840	38600	2160	4700	29000	1930	4700	34800
305WI	<b>25</b>	<b>62</b>	<b>17</b>	<b>9 x 11.91</b>	<b>0.221</b>	<b>15300</b>	<b>30500</b>	<b>26200</b>	<b>13600</b>	<b>30500</b>	<b>31400</b>	<b>14800</b>	<b>29500</b>	<b>23600</b>	<b>13200</b>	<b>29500</b>	<b>28300</b>
7305	0.9843	2.4409	0.6693	9 x 15/32	0.49	3450	6850	26200	3060	6850	31400	3350	6630	23600	2970	6630	28300
306WI	<b>30</b>	<b>72</b>	<b>19</b>	<b>10 x 13.49</b>	<b>0.328</b>	<b>22200</b>	<b>34120</b>	<b>22100</b>	<b>19800</b>	<b>34120</b>	<b>26500</b>	<b>21500</b>	<b>39900</b>	<b>19900</b>	<b>19100</b>	<b>39900</b>	<b>23900</b>
7306	1.1811	2.8346	0.7480	10 x 17/32	0.72	4990	9270	22100	4440	9270	26500	4820	8960	19900	4290	8960	23900
307WI	<b>35</b>	<b>80</b>	<b>21</b>	<b>10 x 14.29</b>	<b>0.443</b>	<b>25600</b>	<b>46200</b>	<b>19200</b>	<b>22800</b>	<b>46200</b>	<b>23000</b>	<b>24700</b>	<b>44500</b>	<b>17300</b>	<b>22000</b>	<b>44500</b>	<b>20800</b>
7307	1.3780	3.1496	0.8268	10 x 9/16	0.98	5700	10400	19200	5130	10400	23000	5600	10000	17300	4940	10000	20800
308WI	<b>40</b>	<b>90</b>	<b>23</b>	<b>11 x 15.88</b>	<b>0.608</b>	<b>35000</b>	<b>59700</b>	<b>16900</b>	<b>31200</b>	<b>59700</b>	<b>20300</b>	<b>33800</b>	<b>57500</b>	<b>15200</b>	<b>30100</b>	<b>57500</b>	<b>18200</b>
7308	1.5748	3.5433	0.9055	11 x 5/8	1.34	7800	13400	16900	7010	13400	20300	7600	12900	15200	6770	12900	18200
309WI	<b>45</b>	<b>100</b>	<b>25</b>	<b>10 x 17.46</b>	<b>0.809</b>	<b>38700</b>	<b>66500</b>	<b>15100</b>	<b>34500</b>	<b>66500</b>	<b>18100</b>	<b>37400</b>	<b>64100</b>	<b>13600</b>	<b>33300</b>	<b>64100</b>	<b>16300</b>
7309	1.7717	3.9370	0.9843	10 x 11/16	1.78	8650	15000	15100	7750	15000	18100	8500	14400	13600	7480	14400	16300
310WI	<b>50</b>	<b>110</b>	<b>27</b>	<b>10 x 19.05</b>	<b>1.046</b>	<b>46200</b>	<b>77900</b>	<b>13600</b>	<b>41200</b>	<b>77900</b>	<b>16300</b>	<b>44700</b>	<b>75100</b>	<b>12200</b>	<b>39800</b>	<b>75100</b>	<b>14600</b>
7310	1.9685	4.3307	1.0630	10 x 3/4	2.31	10400	17500	13600	9250	17500	16300	10000	16900	12200	8940	16900	14600
311WI	<b>55</b>	<b>120</b>	<b>29</b>	<b>10 x 20.64</b>	<b>1.332</b>	<b>54600</b>	<b>90200</b>	<b>12400</b>	<b>48600</b>	<b>90200</b>	<b>14900</b>	<b>52600</b>	<b>86700</b>	<b>11200</b>	<b>46800</b>	<b>86700</b>	<b>13400</b>
7311	2.1654	4.7244	1.1417	10 x 13/16	2.94	12200	20300	12400	10900	20300	14900	11800	19500	11200	10500	19500	13400
312WI	<b>60</b>	<b>130</b>	<b>31</b>	<b>10 x 22.23</b>	<b>1.665</b>	<b>63500</b>	<b>103100</b>	<b>11400</b>	<b>56600</b>	<b>103100</b>	<b>13700</b>	<b>61000</b>	<b>99100</b>	<b>10300</b>	<b>54400</b>	<b>99100</b>	<b>12400</b>
7312	2.3622	5.1181	1.2205	10 x 7/8	3.67	14300	23200	11400	12700	23200	13700	13700	22300	10300	12200	22300	12400
313WI	<b>65</b>	<b>140</b>	<b>33</b>	<b>11 x 23.81</b>	<b>2.101</b>	<b>80500</b>	<b>124400</b>	<b>10500</b>	<b>71700</b>	<b>124400</b>	<b>12600</b>	<b>77400</b>	<b>119700</b>	<b>9500</b>	<b>68900</b>	<b>119700</b>	<b>11400</b>
7313	2.5591	5.5118	1.2992	11 x 15/16	4.63	18000	28000	10500	16100	28000	12600	17300	26900	9500	15500	26900	11400
314WI	<b>70</b>	<b>150</b>	<b>35</b>	<b>11 x 25.40</b>	<b>2.548</b>	<b>91900</b>	<b>139900</b>	<b>9800</b>	<b>81800</b>	<b>139900</b>	<b>11800</b>	<b>88300</b>	<b>134500</b>	<b>8800</b>	<b>78500</b>	<b>134500</b>	<b>10600</b>
7314	2.7559	5.9055	1.3780	11 x 1	5.62	20800	31500	9800	18400	31500	11800	20000	30200	8800	17700	30200	10600
319WI	<b>95</b>	<b>200</b>	<b>45</b>	<b>10 x 34.93</b>	<b>5.587</b>	<b>155900</b>	<b>204400</b>	<b>7400</b>	<b>138800</b>	<b>204400</b>	<b>8900</b>	<b>150400</b>	<b>196800</b>	<b>6700</b>	<b>133900</b>	<b>196800</b>	<b>8000</b>
7319	3.7402	7.8740	1.7717	10 x 1 3/8	12.32	35100	46000	7400	31200	46000	8900	33800	44200	6700	30100	44200	8000

<sup>(N<sub>g</sub>)</sup>For a single, grease-lubricated, spring-preloaded bearing. This value to be used in permissible operating speed (Sp) calculation.

<sup>(1)</sup>Width tolerance of preloaded bearing set +0.000/-0.254 mm (+0.0000/-0.0100 in.).

<sup>(2)</sup>Fill weights based upon specific gravity of 0.99.

<sup>(3)</sup>C is ISO designation for 15° contact angle, 2 is Timken designation for 15° contact angle.

<sup>(4)</sup>E is ISO designation for 25° contact angle, 3 is Timken designation for 25° contact angle.

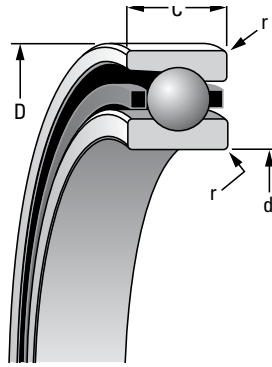

r Rad. <sup>(2)</sup>	Suggested Shoulder Diameters				Shaft Diameter		Mounting Fits		Fixed				Floating			
	Shaft		Housing						Housing Bore (Stationary)		Mounting Fits		Housing Bore (Stationary)		Mounting Fits	
	Max.	Min.	Max.	Min.	Max.	Min.	Loose	Tight	Max.	Min.	Tight	Loose	Max.	Min.	Loose	Loose
mm in.	mm in.	mm in.	mm in.	mm in.	mm in.	mm in.	mm in.	mm in.	mm in.	mm in.	mm in.	mm in.	mm in.	mm in.	mm in.	mm in.
<b>1.0</b> 0.039	<b>17.7</b> 0.70	<b>17.4</b> 0.69	<b>32.1</b> 1.27	<b>31.9</b> 1.26	<b>12.000</b> 0.47240	<b>11.995</b> 0.47220	<b>0.005</b> 0.00020	<b>0.004</b> 0.00015	<b>37.006</b> 1.45700	<b>37.000</b> 1.45670	<b>0.000</b> 0.00000	<b>0.012</b> 0.00050	<b>37.010</b> 1.45710	<b>37.005</b> 1.45690	<b>0.016</b> 0.00070	<b>0.005</b> 0.00020
<b>1.0</b> 0.039	<b>22.2</b> 0.88	<b>22.0</b> 0.87	<b>35.7</b> 1.41	<b>35.4</b> 1.40	<b>15.000</b> 0.59060	<b>14.995</b> 0.59040	<b>0.005</b> 0.00020	<b>0.004</b> 0.00015	<b>42.006</b> 1.65380	<b>42.000</b> 1.65350	<b>0.000</b> 0.00000	<b>0.012</b> 0.00050	<b>42.010</b> 1.65390	<b>42.005</b> 1.65370	<b>0.016</b> 0.00070	<b>0.005</b> 0.00020
<b>1.0</b> 0.039	<b>22.7</b> 0.90	<b>22.5</b> 0.89	<b>42.0</b> 1.66	<b>41.8</b> 1.65	<b>17.000</b> 0.66930	<b>16.995</b> 0.66910	<b>0.005</b> 0.00020	<b>0.004</b> 0.00015	<b>47.006</b> 1.85070	<b>47.000</b> 1.85040	<b>0.000</b> 0.00000	<b>0.012</b> 0.00050	<b>47.012</b> 1.85090	<b>47.007</b> 1.85070	<b>0.018</b> 0.00080	<b>0.007</b> 0.00030
<b>1.0</b> 0.039	<b>30.1</b> 1.19	<b>29.9</b> 1.18	<b>46.6</b> 1.84	<b>46.4</b> 1.83	<b>20.000</b> 0.78740	<b>19.995</b> 0.78720	<b>0.005</b> 0.00020	<b>0.005</b> 0.00020	<b>52.006</b> 2.04750	<b>52.000</b> 2.04720	<b>0.000</b> 0.00000	<b>0.013</b> 0.00055	<b>52.012</b> 2.04770	<b>52.007</b> 2.04750	<b>0.019</b> 0.00080	<b>0.007</b> 0.00030
<b>1.0</b> 0.039	<b>32.1</b> 1.27	<b>31.9</b> 1.26	<b>55.8</b> 2.20	<b>55.5</b> 2.19	<b>25.000</b> 0.98430	<b>24.995</b> 0.98410	<b>0.005</b> 0.00020	<b>0.005</b> 0.00020	<b>62.008</b> 2.44120	<b>62.000</b> 2.44090	<b>0.000</b> 0.00000	<b>0.015</b> 0.00060	<b>62.012</b> 2.44140	<b>62.007</b> 2.44120	<b>0.019</b> 0.00080	<b>0.007</b> 0.00030
<b>1.0</b> 0.039	<b>37.7</b> 1.49	<b>37.5</b> 1.48	<b>65.2</b> 2.57	<b>64.9</b> 2.56	<b>30.000</b> 1.18110	<b>29.995</b> 1.18090	<b>0.005</b> 0.00020	<b>0.005</b> 0.00020	<b>72.008</b> 2.83490	<b>72.000</b> 2.83460	<b>0.000</b> 0.00000	<b>0.015</b> 0.00060	<b>72.011</b> 2.83510	<b>72.007</b> 2.83490	<b>0.019</b> 0.00080	<b>0.007</b> 0.00030
<b>1.5</b> 0.059	<b>43.7</b> 1.72	<b>43.2</b> 1.70	<b>72.1</b> 2.84	<b>71.6</b> 2.82	<b>35.000</b> 1.37800	<b>34.995</b> 1.37780	<b>0.005</b> 0.00020	<b>0.006</b> 0.00025	<b>80.008</b> 3.14990	<b>80.000</b> 3.14960	<b>0.000</b> 0.00000	<b>0.015</b> 0.00060	<b>80.012</b> 3.15010	<b>80.008</b> 3.14990	<b>0.020</b> 0.00080	<b>0.008</b> 0.00030
<b>1.5</b> 0.059	<b>49.8</b> 1.96	<b>49.3</b> 1.94	<b>81.3</b> 3.20	<b>80.8</b> 3.18	<b>40.000</b> 1.57480	<b>39.995</b> 1.57460	<b>0.005</b> 0.00020	<b>0.006</b> 0.00025	<b>90.008</b> 3.54360	<b>90.000</b> 3.54330	<b>0.000</b> 0.00000	<b>0.016</b> 0.00060	<b>90.015</b> 3.54390	<b>90.007</b> 3.54360	<b>0.023</b> 0.00090	<b>0.007</b> 0.00030
<b>1.5</b> 0.059	<b>55.9</b> 2.20	<b>55.4</b> 2.18	<b>90.2</b> 3.55	<b>89.7</b> 3.53	<b>45.000</b> 1.77170	<b>44.995</b> 1.77150	<b>0.005</b> 0.00020	<b>0.006</b> 0.00025	<b>100.008</b> 3.93730	<b>100.000</b> 3.93700	<b>0.000</b> 0.00000	<b>0.016</b> 0.00060	<b>100.018</b> 3.93770	<b>100.010</b> 3.93740	<b>0.025</b> 0.00100	<b>0.010</b> 0.00040
<b>2.0</b> 0.079	<b>61.2</b> 2.41	<b>60.7</b> 2.39	<b>99.8</b> 3.93	<b>99.3</b> 3.91	<b>50.000</b> 1.96850	<b>49.995</b> 1.96830	<b>0.005</b> 0.00020	<b>0.006</b> 0.00025	<b>110.008</b> 4.33100	<b>110.000</b> 4.33070	<b>0.000</b> 0.00000	<b>0.016</b> 0.00060	<b>110.018</b> 4.33140	<b>110.010</b> 4.33110	<b>0.025</b> 0.00100	<b>0.010</b> 0.00040
<b>2.0</b> 0.079	<b>67.3</b> 2.65	<b>66.8</b> 2.63	<b>108.7</b> 4.28	<b>108.2</b> 4.26	<b>55.000</b> 2.16540	<b>54.995</b> 2.16520	<b>0.005</b> 0.00020	<b>0.007</b> 0.00030	<b>120.008</b> 4.72470	<b>120.000</b> 4.72440	<b>0.000</b> 0.00000	<b>0.016</b> 0.00060	<b>120.018</b> 4.72510	<b>120.010</b> 4.72480	<b>0.025</b> 0.00100	<b>0.010</b> 0.00040
<b>2.0</b> 0.079	<b>73.1</b> 2.88	<b>72.6</b> 2.86	<b>117.9</b> 4.64	<b>117.3</b> 4.62	<b>60.000</b> 2.36220	<b>59.995</b> 2.36200	<b>0.005</b> 0.00020	<b>0.007</b> 0.00030	<b>130.009</b> 5.11850	<b>130.000</b> 5.11810	<b>0.000</b> 0.00000	<b>0.018</b> 0.00070	<b>130.020</b> 5.11890	<b>130.010</b> 5.11850	<b>0.029</b> 0.00110	<b>0.010</b> 0.00040
<b>2.0</b> 0.079	<b>80.3</b> 3.16	<b>79.8</b> 3.14	<b>126.8</b> 4.99	<b>126.2</b> 4.97	<b>65.000</b> 2.55910	<b>64.995</b> 2.55890	<b>0.005</b> 0.00020	<b>0.007</b> 0.00030	<b>140.009</b> 5.51220	<b>140.000</b> 5.51180	<b>0.000</b> 0.00000	<b>0.018</b> 0.00070	<b>140.020</b> 5.51260	<b>140.010</b> 5.51220	<b>0.029</b> 0.00110	<b>0.010</b> 0.00040
<b>2.0</b> 0.079	<b>85.3</b> 3.36	<b>84.8</b> 3.34	<b>135.6</b> 5.34	<b>135.1</b> 5.32	<b>70.000</b> 2.75590	<b>69.995</b> 2.75570	<b>0.005</b> 0.00020	<b>0.007</b> 0.00030	<b>150.009</b> 5.90590	<b>150.000</b> 5.90550	<b>0.000</b> 0.00000	<b>0.018</b> 0.00070	<b>150.023</b> 5.90640	<b>150.012</b> 5.90600	<b>0.032</b> 0.00120	<b>0.012</b> 0.00050
<b>3.0</b> 0.118	<b>113.2</b> 4.46	<b>112.4</b> 4.43	<b>183.3</b> 7.22	<b>182.5</b> 7.19	<b>95.000</b> 3.74016	<b>94.995</b> 3.73996	<b>0.005</b> 0.00020	<b>0.013</b> 0.00051	<b>200.011</b> 7.87402	<b>200.000</b> 7.87445	<b>0.000</b> 0.00000	<b>0.022</b> 0.00087	<b>200.025</b> 7.87500	<b>200.015</b> 7.87461	<b>0.036</b> 0.00142	<b>0.015</b> 0.00059

**MEDIUM ISO 03 SERIES**  
**2(3)MM300WI (7300C(E)-...-P4S)**  
**DUPLEX PERFORMANCE DATA**

Bearing Number	Preload				Axial Stiffness <sup>(1)</sup>				Radial Stiffness <sup>(1)</sup>				Spacer Offsets <sup>(1)</sup>		
	DUX X-light	DUL Light	DUM Med.	DUH Heavy	X-light	Light	Med.	Heavy	X-light	Light	Med.	Heavy	X-light to Light	Light to Med.	Med. to Heavy
	N lbs.	N lbs.	N lbs.	N lbs.	N/μm 10 <sup>6</sup> lbs./in.	N/μm 10 <sup>6</sup> lbs./in.	N/μm 10 <sup>6</sup> lbs./in.	N/μm 10 <sup>6</sup> lbs./in.	N/μm 10 <sup>6</sup> lbs./in.	N/μm 10 <sup>6</sup> lbs./in.	N/μm 10 <sup>6</sup> lbs./in.	N/μm 10 <sup>6</sup> lbs./in.	μm in.	μm in.	μm in.
2MM301WICR	—	20	70	180	—	17.49	27.81	44.25	—	98.82	153.56	183.30	—	7.87	12.45
7301C-T-P4S	—	5	15	40	—	0.100	0.159	0.253	—	0.565	0.878	1.048	—	0.00031	0.00049
2MM302WICR	20	40	110	220	—	27.46	40.93	57.19	109.97	143.24	164.93	205.51	3.70	7.87	9.14
7302C-T-P4S	5	10	25	50	—	0.157	0.234	0.327	0.628	0.819	0.943	1.175	0.00015	0.00031	0.00036
2MM303WICR	40	70	160	310	—	26.58	38.83	54.57	127.92	147.44	197.46	263.05	3.63	10.92	13.46
7303C-T-P4S	10	15	35	70	—	0.152	0.222	0.312	0.730	0.843	1.129	1.504	0.00014	0.00043	0.00053
2MM304WICR	40	90	220	400	—	33.06	49.85	66.46	140.53	181.72	232.97	289.81	6.14	12.95	12.92
7304C-T-P4S	10	20	50	90	—	0.189	0.285	0.380	0.803	1.039	1.332	1.657	0.00024	0.00051	0.00051
2MM305WICR	90	160	330	620	—	46.17	65.24	88.50	203.85	247.83	318.78	387.86	6.42	12.70	14.99
7305C-T-P4S	20	35	75	140	—	0.264	0.373	0.506	1.164	1.417	1.820	2.215	0.00025	0.00050	0.00059
2MM306WICR	90	180	440	780	—	49.50	74.68	98.47	223.77	271.27	394.56	470.83	7.73	17.27	15.49
7306C-T-P4S	20	40	100	175	—	0.283	0.427	0.563	1.278	1.551	2.253	2.689	0.00030	0.00068	0.00061
2MM307WICR	110	220	560	1000	—	55.97	85.18	114.38	251.87	323.91	438.09	526.52	9.05	18.80	17.78
7307C-T-P4S	25	50	125	225	—	0.320	0.487	0.654	1.438	1.852	2.502	3.007	0.00036	0.00074	0.00070
2MM308WICR	130	290	670	1220	—	64.71	94.62	127.85	290.33	364.67	512.52	620.41	10.56	19.05	20.07
7308C-T-P4S	30	65	150	275	—	0.370	0.541	0.731	1.658	2.085	2.927	3.543	0.00042	0.00075	0.00079
2MM309WICR	180	330	780	1560	—	70.13	103.02	145.17	313.69	393.18	520.48	646.82	10.00	20.57	25.15
7309C-T-P4S	40	75	175	350	—	0.401	0.589	0.830	1.791	2.248	2.972	3.694	0.00039	0.00081	0.00099
2MM310WICR	220	440	1000	1780	—	81.15	117.36	156.01	347.72	445.06	580.34	694.99	12.52	22.35	22.86
7310C-T-P4S	50	100	225	400	—	0.464	0.671	0.892	1.986	2.541	3.314	3.969	0.00049	0.00088	0.00090
2MM311WICR	270	560	1110	2110	—	88.15	121.38	167.20	383.15	496.30	622.37	761.00	15.05	21.34	27.69
7311C-T-P4S	60	125	250	475	—	0.504	0.694	0.956	2.188	2.834	3.554	4.346	0.00059	0.00084	0.00109
2MM312WICR	270	560	1330	2450	—	89.72	133.80	180.85	387.61	506.89	675.70	816.95	14.75	27.94	28.19
7312C-T-P4S	60	125	300	550	—	0.513	0.765	1.034	2.213	2.895	3.859	4.665	0.00058	0.00110	0.00111
2MM313WICR	330	670	1670	3000	—	104.24	157.93	211.28	453.84	585.60	791.90	952.23	14.55	30.48	28.96
7313C-T-P4S	75	150	375	675	—	0.596	0.903	1.208	2.592	3.344	4.522	5.438	0.00057	0.00120	0.00114
2MM314WICR	400	780	1890	3450	—	110.89	166.33	224.22	498.33	633.95	848.58	1024.31	15.49	32.26	32.00
7314C-T-P4S	90	175	425	775	—	0.634	0.951	1.282	2.846	3.620	4.846	5.849	0.00061	0.00127	0.00126
2MM319WICR	670	1330	3110	6230	—	140.44	206.03	290.33	611.00	787.43	1041.02	1293.71	21.67	41.05	50.24
7319C-T-P4S	150	300	700	1400	—	0.803	1.178	1.660	3.489	4.497	5.945	7.388	0.00085	0.00162	0.00198

<sup>(1)</sup>For DB or DF arrangements only. For other mounting arrangements, contact your Timken representative.



**MOUNTING ARRANGEMENTS**

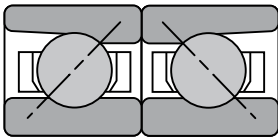

**Back-to-Back  
DB**

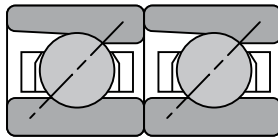

**Tandem  
DT**

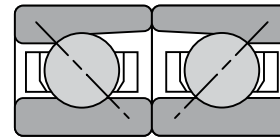

**Face-to-Face  
DF**

Bearing Number	Preload				Axial Stiffness <sup>(1)</sup>				Radial Stiffness <sup>(1)</sup>				Spacer Offsets <sup>(1)</sup>		
	DUX X-light	DUL Light	DUM Med.	DUH Heavy	X-light	Light	Med.	Heavy	X-light	Light	Med.	Heavy	X-light to Light	Light to Med.	Med. to Heavy
	N lbs.	N lbs.	N lbs.	N lbs.	N/ $\mu$ m 10 <sup>6</sup> lbs./in.	N/ $\mu$ m 10 <sup>6</sup> lbs./in.	N/ $\mu$ m 10 <sup>6</sup> lbs./in.	N/ $\mu$ m 10 <sup>6</sup> lbs./in.	N/ $\mu$ m 10 <sup>6</sup> lbs./in.	N/ $\mu$ m 10 <sup>6</sup> lbs./in.	N/ $\mu$ m 10 <sup>6</sup> lbs./in.	N/ $\mu$ m 10 <sup>6</sup> lbs./in.	$\mu$ m in.	$\mu$ m in.	$\mu$ m in.
3MM301WICR 7301E-T-P4S	40 10	90 20	180 40	310 70	— —	58.59 0.335	76.61 0.438	96.37 0.551	96.32 0.550	122.54 0.700	153.78 0.878	183.56 1.048	3.42 0.00013	5.33 0.00021	6.10 0.00024
3MM302WICR 7302E-T-P4S	40 10	90 20	180 40	360 80	— —	66.46 0.380	86.75 0.496	115.08 0.658	108.95 0.622	139.15 0.795	174.90 0.999	217.90 1.244	2.99 0.00012	4.57 0.00018	7.11 0.00028
3MM303WICR 7303E-T-P4S	40 10	110 25	270 60	440 100	— —	63.66 0.364	89.02 0.509	109.49 0.626	93.69 0.535	132.92 0.760	176.19 1.006	207.22 1.183	4.85 0.00019	8.13 0.00032	7.11 0.00028
3MM304WICR 7304E-T-P4S	90 20	160 35	360 80	620 140	— —	79.23 0.453	108.96 0.623	136.77 0.782	136.71 0.781	159.51 0.912	220.02 1.258	261.18 1.491	3.70 0.00015	8.38 0.00033	8.64 0.00034
3MM305WICR 7305E-T-P4S	110 25	220 50	530 120	890 200	— —	101.62 0.581	142.19 0.813	174.90 1.000	165.18 0.943	212.03 1.211	283.21 1.617	333.10 1.902	4.90 0.00019	10.16 0.00040	8.89 0.00035
3MM306WICR 7306E-T-P4S	135 30	270 60	670 150	1110 250	— —	112.29 0.642	159.33 0.911	196.06 1.121	193.95 1.108	252.07 1.439	342.44 1.955	403.21 2.303	4.99 0.00020	11.68 0.00046	9.91 0.00039
3MM307WICR 7307E-T-P4S	180 40	360 80	850 190	1560 350	— —	134.85 0.771	187.84 1.074	241.01 1.378	221.46 1.265	284.26 1.623	378.37 2.161	459.17 2.622	5.93 0.00023	12.19 0.00048	13.21 0.00052
3MM308WICR 7308E-T-P4S	220 50	440 100	1110 250	1780 400	— —	150.41 0.860	214.08 1.224	259.20 1.482	261.11 1.491	336.84 1.923	456.64 2.608	530.40 3.029	6.22 0.00025	14.48 0.00057	11.18 0.00044
3MM309WICR 7309E-T-P4S	270 60	530 120	1330 300	2220 500	— —	165.98 0.949	235.94 1.349	290.51 1.661	269.80 1.541	332.14 1.899	468.66 2.676	551.00 3.146	7.20 0.00028	15.75 0.00062	13.46 0.00053
3MM310WICR 7310E-T-P4S	310 70	620 140	1560 350	2670 600	— —	178.75 1.022	254.13 1.453	316.57 1.810	293.47 1.676	360.12 2.059	510.36 2.914	605.40 3.457	7.83 0.00031	17.27 0.00068	15.49 0.00061
3MM311WICR 7311E-T-P4S	400 90	780 175	1780 400	3110 700	— —	198.16 1.133	272.32 1.557	342.10 1.956	328.74 1.877	407.34 2.329	547.14 3.124	653.40 3.731	8.51 0.00034	17.02 0.00067	17.27 0.00068
3MM312WICR 7312E-T-P4S	450 100	890 200	2000 450	3560 800	— —	213.38 1.220	291.21 1.665	367.81 2.103	347.62 1.985	450.02 2.573	582.53 3.326	699.31 3.993	9.35 0.00037	17.53 0.00069	18.80 0.00074
3MM313WICR 7313E-T-P4S	560 125	1110 250	2670 600	4450 1000	— —	249.23 1.425	348.93 1.995	429.55 2.456	409.70 2.340	525.26 2.999	701.21 4.004	824.51 4.708	10.03 0.00039	20.83 0.00082	18.29 0.00072
3MM314WICR 7314E-T-P4S	620 140	1220 275	2890 650	5120 1150	— —	262.52 1.501	365.02 2.087	460.34 2.632	433.61 2.476	552.97 3.158	735.10 4.198	881.07 5.031	10.22 0.00040	21.08 0.00083	21.59 0.00085
3MM319WICR 7319E-T-P4S	1070 240	2110 475	4890 1100	8900 2000	— —	328.81 1.880	453.52 2.593	578.22 3.306	541.62 3.093	692.64 3.955	914.62 5.223	1105.79 6.315	14.24 0.00056	28.19 0.00111	30.99 0.00122

**MEDIUM ISO 03 SERIES**  
**2(3)MM300WI (7300C(E)-...-P4S)**  
**SPEED CAPABILITY DATA**

Fafnir Bearing Number	Timken ISO Bearing Number	Grease Capacity <sup>(1)</sup>				Operating Speeds <sup>(4)</sup> (DB Mounting) <sup>(5)</sup>					
		Low Speed <sup>(2)</sup>		High Speed <sup>(3)</sup>		Grease			Oil		
		25%	40%	10%	15%	DUL	DUM	DUH	DUL	DUM	DUH
		grams	grams	grams	grams	RPM	RPM	RPM	RPM	RPM	RPM
2MM301WICR	7301C-T-P4S	0.60	1.00	0.40	0.53	35700	28600	19000	60700	48600	32400
2MM302WICR	7302C-T-P4S	0.70	1.20	0.49	0.65	28600	22900	15200	48600	38900	25900
2MM303WICR	7303C-T-P4S	1.20	2.00	0.83	1.10	27600	22100	14700	46900	37500	25000
2MM304WICR	7304C-T-P4S	1.50	2.50	1.03	1.38	24200	19300	12900	41100	32800	21900
2MM305WICR	7305C-T-P4S	2.30	3.80	1.57	2.09	19700	15700	10500	33400	26700	17800
2MM306WICR	7306C-T-P4S	3.50	5.60	2.35	3.14	16600	13300	8800	28200	22500	15000
2MM307WICR	7307C-T-P4S	4.60	7.40	3.07	4.10	14400	11500	7700	24500	19600	13100
2MM308WICR	7308C-T-P4S	6.40	10.20	4.25	5.66	12700	10100	6800	21500	17200	11500
2MM309WICR	7309C-T-P4S	8.50	13.60	5.68	7.58	11300	9100	6000	19300	15400	10300
2MM310WICR	7310C-T-P4S	11.10	17.80	7.40	9.90	10200	8200	5400	17300	13900	9200
2MM311WICR	7311C-T-P4S	14.20	22.70	9.50	12.60	9300	7400	5000	15800	12600	8400
2MM312WICR	7312C-T-P4S	17.70	28.30	11.80	15.80	8600	6800	4600	14500	11600	7800
2MM313WICR	7313C-T-P4S	20.70	33.20	13.80	18.50	7900	6300	4200	13400	10700	7100
2MM314WICR	7314C-T-P4S	25.20	40.30	16.80	22.40	7400	5900	3900	12500	10000	6700
2MM319WICR	7319C-T-P4S	60.90	97.40	40.60	54.10	5600	4400	3000	9400	7500	5000
3MM301WICR	7301E-T-P4S	0.60	1.00	0.40	0.53	32130	25740	17100	54630	43740	29160

<sup>(1)</sup>Fill weights based on specific gravity of 0.99.

<sup>(2)</sup>Low speed <500000 dN.

<sup>(3)</sup>High speed > 500000 dN.

<sup>(4)</sup>For ceramic ball complements, use 120 percent of speeds shown.

<sup>(5)</sup>For other mounting arrangement configurations, refer to the engineering section on permissible speed calculation methods.

**MOUNTING ARRANGEMENTS**

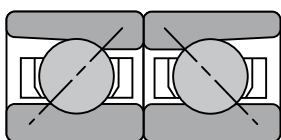

**Back-to-Back  
DB**

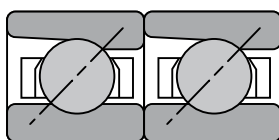

**Tandem  
DT**

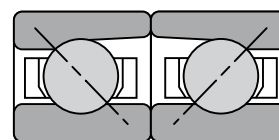

**Face-to-Face  
DF**

Fafnir Bearing Number	Timken ISO Bearing Number	Grease Capacity <sup>(1)</sup>				Operating Speeds <sup>(4)</sup> (DB Mounting) <sup>(5)</sup>					
		Low Speed <sup>(2)</sup>		High Speed <sup>(3)</sup>		Grease			Oil		
		25%	40%	10%	15%	DUL	DUM	DUH	DUL	DUM	DUH
		grams	grams	grams	grams	RPM	RPM	RPM	RPM	RPM	RPM
3MM302WICR	7302E-T-P4S	0.70	1.20	0.49	0.65	25740	20610	13680	43740	35010	23310
3MM303WICR	7303E-T-P4S	1.20	2.00	0.83	1.10	24840	19890	13230	42210	33750	22500
3MM304WICR	7304E-T-P4S	1.50	2.50	1.03	1.38	21780	17370	11610	36990	29520	19710
3MM305WICR	7305E-T-P4S	2.30	3.80	1.57	2.09	17730	14130	9450	30060	24030	16020
3MM306WICR	7306E-T-P4S	3.50	5.60	2.35	3.14	14940	11970	7920	25380	20250	13500
3MM307WICR	7307E-T-P4S	4.60	7.40	3.07	4.10	12960	10350	6930	22050	17640	11790
3MM308WICR	7308E-T-P4S	6.40	10.20	4.25	5.66	11430	9090	6120	19350	15480	10350
3MM309WICR	7309E-T-P4S	8.50	13.60	5.68	7.58	10170	8190	5400	17370	13860	9270
3MM310WICR	7310E-T-P4S	11.10	17.80	7.40	9.90	9180	7380	4860	15570	12510	8280
3MM311WICR	7311E-T-P4S	14.20	22.70	9.50	12.60	8370	6660	4500	14220	11340	7560
3MM312WICR	7312E-T-P4S	17.70	28.30	11.80	15.80	7740	6120	4140	13050	10440	7020
3MM313WICR	7313E-T-P4S	20.70	33.20	13.80	18.50	7110	5670	3780	12060	9630	6390
3MM314WICR	7314E-T-P4S	25.20	40.30	16.80	22.40	6660	5310	3510	11250	9000	6030
3MM319WICR	7319E-T-P4S	60.90	97.40	40.60	54.10	5040	3960	2700	8460	6750	4500

**MEDIUM ISO 03 SERIES**  
**MM300K (6300-...-P4S)**  
**SUPER PRECISION MMV**

Running accuracy and performance meet ABEC 9 (ISO P2) levels. Other features conform to ABEC 7 (ISO P4) requirements.

**DEEP-GROOVE (CONRAD) CONSTRUCTION**

- Incorporates high shoulder on both inner and outer rings.
- Balls separated by two-piece and piloted cage.

Bearing Number	d Bore	D O.D.	C Width <sup>(1)</sup>	Ball Qty. x Dia.	Bearing Wt.	Load Ratings						r Rad. <sup>(2)</sup>
						Steel Ball			Ceramic Ball			
						C <sub>0</sub> Static	C <sub>e</sub> Dynamic	Speed Rating <sup>(Ng)</sup>	C <sub>0</sub> Static	C <sub>e</sub> Dynamic	Speed Rating <sup>(Ng)</sup>	
mm in.	mm in.	mm in.	mm in.	kg lbs.	N lbs.	N lbs.	RPM	N lbs.	N lbs.	RPM	mm in.	
MM305K	<b>25</b>	<b>62</b>	<b>17</b>	<b>7 x 11.9</b>	<b>0.222</b>	<b>12100</b>	<b>26200</b>	<b>26500</b>	<b>10800</b>	<b>26200</b>	<b>31800</b>	<b>1.0</b>
6305	0.9843	2.4409	0.6693	7 x 1 <sup>1</sup> / <sub>2</sub>	0.49	2730	5890	26500	2430	5890	31800	0.039
MM306K	<b>30</b>	<b>72</b>	<b>19</b>	<b>7 x 13.5</b>	<b>0.327</b>	<b>15800</b>	<b>33100</b>	<b>22300</b>	<b>14100</b>	<b>33100</b>	<b>26760</b>	<b>1.0</b>
6306	1.1811	2.8346	0.7480	7 x 1 <sup>1</sup> / <sub>2</sub>	0.72	3560	7440	22300	3160	7440	26760	0.039
MM307K	<b>35</b>	<b>80</b>	<b>21</b>	<b>7 x 14.3</b>	<b>0.431</b>	<b>18300</b>	<b>37100</b>	<b>19400</b>	<b>16300</b>	<b>37100</b>	<b>23280</b>	<b>1.5</b>
6307	1.3780	3.1496	0.8268	7 x 9/ <sub>16</sub>	0.95	4120	8340	19400	3670	8340	23280	0.059
MM308K	<b>40</b>	<b>90</b>	<b>23</b>	<b>7 x 15.9</b>	<b>0.594</b>	<b>22800</b>	<b>45000</b>	<b>17100</b>	<b>20300</b>	<b>45000</b>	<b>20520</b>	<b>1.5</b>
6308	1.5748	3.5433	0.9055	7 x 5/ <sub>8</sub>	1.31	5120	10100	17100	4560	10100	20520	0.059
MM309K	<b>45</b>	<b>100</b>	<b>25</b>	<b>8 x 17.5</b>	<b>0.807</b>	<b>31700</b>	<b>58500</b>	<b>15200</b>	<b>28200</b>	<b>58500</b>	<b>18240</b>	<b>1.5</b>
6309	1.7717	3.9370	0.9843	8 x 1 <sup>1</sup> / <sub>16</sub>	1.78	7120	13200	15200	6340	13200	18240	0.059
MM310K	<b>50</b>	<b>110</b>	<b>27</b>	<b>8 x 19.1</b>	<b>1.052</b>	<b>37900</b>	<b>68600</b>	<b>13800</b>	<b>33700</b>	<b>68600</b>	<b>16560</b>	<b>1.5</b>
6310	1.9685	4.3307	1.0630	8 x 3/ <sub>4</sub>	2.32	8510	15400	13800	7570	15400	16560	0.059
MM311K	<b>55</b>	<b>120</b>	<b>29</b>	<b>8 x 20.6</b>	<b>1.329</b>	<b>44600</b>	<b>79300</b>	<b>12500</b>	<b>39700</b>	<b>79300</b>	<b>15000</b>	<b>2.0</b>
6311	2.1654	4.7244	1.1417	8 x 1 <sup>3</sup> / <sub>16</sub>	2.93	10000	17800	12500	8920	17800	15000	0.079
MM312K	<b>60</b>	<b>130</b>	<b>31</b>	<b>8 x 22.2</b>	<b>1.665</b>	<b>51800</b>	<b>90700</b>	<b>11500</b>	<b>46100</b>	<b>90700</b>	<b>13800</b>	<b>2.0</b>
6312	2.3622	5.1181	1.2205	8 x 7/ <sub>8</sub>	3.67	11700	20400	11500	10400	20400	13800	0.079
MM313K	<b>65</b>	<b>140</b>	<b>33</b>	<b>8 x 23.8</b>	<b>2.046</b>	<b>59700</b>	<b>102700</b>	<b>10700</b>	<b>53100</b>	<b>102700</b>	<b>12840</b>	<b>2.0</b>
6313	2.5591	5.5118	1.2992	8 x 1 <sup>5</sup> / <sub>16</sub>	4.51	13400	23100	10700	11900	23100	12840	0.079
MM314K	<b>70</b>	<b>150</b>	<b>35</b>	<b>8 x 25.4</b>	<b>2.486</b>	<b>68000</b>	<b>115500</b>	<b>9900</b>	<b>60600</b>	<b>115500</b>	<b>11880</b>	<b>2.0</b>
6314	2.7559	5.9055	1.3780	8 x 1	5.48	15300	26000	9900	13600	26000	11880	0.079

<sup>(Ng)</sup>For a single, grease-lubricated, spring-preloaded bearing. This value to be used in permissible operating speed (Sp) calculation.

<sup>(1)</sup>Width tolerance of preloaded bearing set +0.000/-0.254 mm (+0.0000/-0.0100 in.).

<sup>(2)</sup>ABMA STD 20 (ras max).

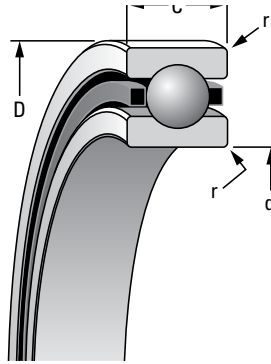

Suggested Shoulder Diameters				Shaft Diameter		Mounting Fits		Fixed				Floating			
Shaft		Housing						Housing Bore (Stationary)		Mounting Fits		Housing Bore (Stationary)		Mounting Fits	
Max.	Min.	Max.	Min.	Max.	Min.	Loose	Tight	Max.	Min.	Tight	Loose	Max.	Min.	Loose	Loose
mm in.	mm in.	mm in.	mm in.	mm in.	mm in.	mm in.	mm in.	mm in.	mm in.	mm in.	mm in.	mm in.	mm in.	mm in.	mm in.
<b>32.1</b>	<b>31.9</b>	<b>55.8</b>	<b>55.5</b>	<b>25.000</b>	<b>24.995</b>	<b>0.005</b>	<b>0.005</b>	<b>62.008</b>	<b>62.000</b>	<b>0.000</b>	<b>0.015</b>	<b>62.012</b>	<b>62.007</b>	<b>0.019</b>	<b>0.007</b>
1.27	1.26	2.20	2.19	0.98430	0.98410	0.00020	0.00020	2.44120	2.44090	0.00000	0.00060	2.44140	2.44120	0.00080	0.00030
<b>37.7</b>	<b>37.5</b>	<b>65.2</b>	<b>64.9</b>	<b>30.000</b>	<b>29.995</b>	<b>0.005</b>	<b>0.005</b>	<b>72.008</b>	<b>72.000</b>	<b>0.000</b>	<b>0.015</b>	<b>72.011</b>	<b>72.007</b>	<b>0.019</b>	<b>0.007</b>
1.49	1.48	2.57	2.56	1.18110	1.18090	0.00020	0.00020	2.83490	2.83460	0.00000	0.00060	2.83510	2.83490	0.00080	0.00030
<b>43.7</b>	<b>43.2</b>	<b>72.1</b>	<b>71.6</b>	<b>35.000</b>	<b>34.995</b>	<b>0.005</b>	<b>0.006</b>	<b>80.008</b>	<b>80.000</b>	<b>0.000</b>	<b>0.015</b>	<b>80.012</b>	<b>80.008</b>	<b>0.020</b>	<b>0.008</b>
1.72	1.70	2.84	2.82	1.37800	1.37780	0.00020	0.00025	3.14990	3.14960	0.00000	0.00060	3.15010	3.14990	0.00080	0.00030
<b>49.8</b>	<b>49.3</b>	<b>81.3</b>	<b>80.8</b>	<b>40.000</b>	<b>39.995</b>	<b>0.005</b>	<b>0.006</b>	<b>90.008</b>	<b>90.000</b>	<b>0.000</b>	<b>0.016</b>	<b>90.015</b>	<b>90.007</b>	<b>0.023</b>	<b>0.007</b>
1.96	1.94	3.20	3.18	1.57480	1.57460	0.00020	0.00025	3.54360	3.54330	0.00000	0.00060	3.54390	3.54360	0.00090	0.00030
<b>55.9</b>	<b>55.4</b>	<b>90.2</b>	<b>89.7</b>	<b>45.000</b>	<b>44.995</b>	<b>0.005</b>	<b>0.006</b>	<b>100.008</b>	<b>100.000</b>	<b>0.000</b>	<b>0.016</b>	<b>100.018</b>	<b>100.010</b>	<b>0.025</b>	<b>0.010</b>
2.20	2.18	3.55	3.53	1.77170	1.77150	0.00020	0.00025	3.93730	3.93700	0.00000	0.00060	3.93770	3.93740	0.00100	0.00040
<b>61.2</b>	<b>60.7</b>	<b>99.8</b>	<b>99.3</b>	<b>50.000</b>	<b>49.995</b>	<b>0.005</b>	<b>0.006</b>	<b>110.008</b>	<b>110.000</b>	<b>0.000</b>	<b>0.016</b>	<b>110.018</b>	<b>110.010</b>	<b>0.025</b>	<b>0.010</b>
2.41	2.39	3.93	3.91	1.96850	1.96830	0.00020	0.00025	4.33100	4.33070	0.00000	0.00060	4.33140	4.33110	0.00100	0.00040
<b>67.3</b>	<b>66.8</b>	<b>108.7</b>	<b>108.2</b>	<b>55.000</b>	<b>54.995</b>	<b>0.005</b>	<b>0.007</b>	<b>120.008</b>	<b>120.000</b>	<b>0.000</b>	<b>0.016</b>	<b>120.018</b>	<b>120.010</b>	<b>0.025</b>	<b>0.010</b>
2.65	2.63	4.28	4.26	2.16540	2.16520	0.00020	0.00030	4.72470	4.72440	0.00000	0.00060	4.72510	4.72480	0.00100	0.00040
<b>43.2</b>	<b>72.6</b>	<b>117.9</b>	<b>117.3</b>	<b>60.000</b>	<b>59.995</b>	<b>0.005</b>	<b>0.007</b>	<b>130.009</b>	<b>130.000</b>	<b>0.000</b>	<b>0.018</b>	<b>130.020</b>	<b>130.010</b>	<b>0.029</b>	<b>0.010</b>
2.88	2.86	4.64	4.62	2.36220	2.36200	0.00020	0.00030	5.11850	5.11810	0.00000	0.00070	5.11890	5.11850	0.00110	0.00040
<b>80.3</b>	<b>79.8</b>	<b>126.8</b>	<b>126.2</b>	<b>65.000</b>	<b>64.995</b>	<b>0.005</b>	<b>0.007</b>	<b>140.009</b>	<b>140.000</b>	<b>0.000</b>	<b>0.018</b>	<b>140.020</b>	<b>140.010</b>	<b>0.029</b>	<b>0.010</b>
3.16	3.14	4.99	4.97	2.55910	2.55890	0.00020	0.00030	5.51220	5.51180	0.00000	0.00070	5.51260	5.51220	0.00110	0.00040
<b>85.3</b>	<b>84.8</b>	<b>135.6</b>	<b>135.1</b>	<b>70.000</b>	<b>69.995</b>	<b>0.005</b>	<b>0.007</b>	<b>150.009</b>	<b>150.000</b>	<b>0.000</b>	<b>0.018</b>	<b>150.023</b>	<b>150.012</b>	<b>0.032</b>	<b>0.012</b>
3.36	3.34	5.34	5.32	2.75590	2.75570	0.00020	0.00030	5.90590	5.90550	0.00000	0.00070	5.90640	5.90600	0.00120	0.00050

**BALL SCREW SUPPORT SERIES  
METRIC SERIES**

- Designed for maximum axial rigidity, low drag torque and extreme control of lateral eccentricity.
- Manufactured to ABEC 9/ISO P2 axial tolerances.
- Non-separable angular-contact type design (60 degree contact angle).
- Manufactured to ABEC 7/ISO P4 radial and envelope

tolerances.

- Maximum complement of balls.
- Supplied prelubricated with heavy-duty grease NLGI #2.
- Packaged in DB arrangement [can be mounted in duplexed pairs and in multiplexed sets in either back-to-back (DB), face-to-face (DF) or tandem (DT) arrangements].

Bearing Number	d Bore	D O.D.	C Width <sup>(1)</sup>	Ball Qty. x Dia.	Wt. <sup>(2)</sup>	r Rad. <sup>(3)</sup>	Suggested Shoulder Diameters				Shaft Dia.		Housing Dia.	
							Shaft		Housing		Max.	Min.	Max.	Min.
							Max.	Min.	Max.	Min.	mm in.	mm in.	mm in.	mm in.
MM12BS32	<b>12</b>	<b>32</b>	<b>10</b>	<b>11 x 4.8</b>	<b>0.040</b>	<b>0.8</b>	<b>17.630</b>	<b>17.370</b>	<b>26.630</b>	<b>26.370</b>	<b>11.996</b>	<b>11.992</b>	<b>32.006</b>	<b>32.000</b>
	0.4724	1.2598	0.3937	11 x 3/16	0.09	0.031	0.6941	0.6839	1.0484	1.0382	0.4723	0.4721	1.2601	1.2598
MM15BS35	<b>15</b>	<b>35</b>	<b>11</b>	<b>13 x 4.8</b>	<b>0.050</b>	<b>0.8</b>	<b>20.630</b>	<b>20.370</b>	<b>29.630</b>	<b>29.370</b>	<b>14.996</b>	<b>14.992</b>	<b>35.006</b>	<b>35.000</b>
	0.5906	1.3780	0.4331	13 x 3/16	0.11	0.031	0.8122	0.8020	1.1665	1.1563	0.5904	0.5902	1.3782	1.3780
MM17BS47	<b>17</b>	<b>47</b>	<b>15</b>	<b>12 x 7.9</b>	<b>0.130</b>	<b>0.8</b>	<b>23.130</b>	<b>22.870</b>	<b>41.630</b>	<b>41.370</b>	<b>16.996</b>	<b>16.992</b>	<b>47.006</b>	<b>47.000</b>
	0.6693	1.8504	0.5906	12 x 5/8	0.29	0.031	0.9106	0.9004	1.6390	1.6287	0.6691	0.6690	1.8506	1.8504
MM20BS47	<b>20</b>	<b>47</b>	<b>15</b>	<b>12 x 7.9</b>	<b>0.120</b>	<b>0.8</b>	<b>26.130</b>	<b>25.870</b>	<b>41.630</b>	<b>41.370</b>	<b>19.995</b>	<b>19.990</b>	<b>47.006</b>	<b>47.000</b>
	0.7874	1.8504	0.5906	12 x 5/8	0.26	0.031	1.0287	1.0185	1.6390	1.6287	0.7872	0.7870	1.8506	1.8504
MM25BS52	<b>25</b>	<b>52</b>	<b>15</b>	<b>13 x 7.9</b>	<b>0.140</b>	<b>0.8</b>	<b>31.630</b>	<b>31.370</b>	<b>43.630</b>	<b>43.370</b>	<b>24.995</b>	<b>24.990</b>	<b>52.007</b>	<b>52.000</b>
	0.9843	2.0472	0.5906	13 x 5/8	0.37	0.031	1.2453	1.2350	1.7177	1.7075	0.9841	0.9839	2.0475	2.0472
MM25BS62	<b>25</b>	<b>62</b>	<b>15</b>	<b>17 x 7.9</b>	<b>0.230</b>	<b>0.8</b>	<b>35.130</b>	<b>34.870</b>	<b>56.130</b>	<b>55.870</b>	<b>24.995</b>	<b>24.990</b>	<b>62.007</b>	<b>62.000</b>
	0.9843	2.4409	0.5906	17 x 5/8	0.51	0.031	1.3831	1.3728	2.2098	2.1996	0.9841	0.9839	2.4412	2.4409
MM30BS62	<b>30</b>	<b>62</b>	<b>15</b>	<b>17 x 7.9</b>	<b>0.210</b>	<b>0.8</b>	<b>40.130</b>	<b>39.870</b>	<b>56.130</b>	<b>55.870</b>	<b>29.995</b>	<b>29.990</b>	<b>62.007</b>	<b>62.000</b>
	1.1811	2.4409	0.5906	17 x 5/8	0.46	0.031	1.5799	1.5697	2.2098	2.1996	1.1809	1.1807	2.4412	2.4409
MM30BS72	<b>30</b>	<b>72</b>	<b>15</b>	<b>18 x 8.7</b>	<b>0.320</b>	<b>0.8</b>	<b>40.130</b>	<b>39.870</b>	<b>56.130</b>	<b>55.870</b>	<b>29.995</b>	<b>29.990</b>	<b>72.007</b>	<b>72.000</b>
	1.1811	2.8346	0.5906	18 x 7/8	0.71	0.031	1.5799	1.5697	2.2098	2.1996	1.1809	1.1807	2.8349	2.8346
MM35BS72	<b>35</b>	<b>72</b>	<b>15</b>	<b>18 x 8.7</b>	<b>0.290</b>	<b>0.8</b>	<b>42.130</b>	<b>41.870</b>	<b>64.130</b>	<b>63.870</b>	<b>34.994</b>	<b>34.988</b>	<b>72.007</b>	<b>72.000</b>
	1.3780	2.8346	0.5906	18 x 7/8	0.64	0.031	1.6587	1.6484	2.5248	2.5146	1.3777	1.3775	2.8349	2.8346
MM35BS100	<b>35</b>	<b>100</b>	<b>20</b>	<b>18 x 12.7</b>	<b>0.860</b>	<b>0.8</b>	<b>42.130</b>	<b>41.870</b>	<b>90.130</b>	<b>89.870</b>	<b>34.994</b>	<b>34.988</b>	<b>100.007</b>	<b>100.000</b>
	1.3780	3.9370	0.7874	18 x 1/2	1.90	0.031	1.6587	1.6484	3.5484	3.5382	1.3777	1.3775	3.9373	3.9370
MM40BS72	<b>40</b>	<b>72</b>	<b>15</b>	<b>18 x 8.7</b>	<b>0.250</b>	<b>0.8</b>	<b>47.130</b>	<b>46.870</b>	<b>64.130</b>	<b>63.870</b>	<b>39.994</b>	<b>39.998</b>	<b>72.007</b>	<b>72.000</b>
	1.5748	2.8346	0.5906	18 x 7/8	0.55	0.031	1.8555	1.8453	2.5248	2.5146	1.5746	1.5743	2.8349	2.8346
MM40BS90	<b>40</b>	<b>90</b>	<b>15</b>	<b>24 x 8.7</b>	<b>0.490</b>	<b>0.8</b>	<b>47.130</b>	<b>46.870</b>	<b>82.130</b>	<b>81.870</b>	<b>39.994</b>	<b>39.988</b>	<b>90.008</b>	<b>90.000</b>
	1.5748	3.5433	0.5906	24 x 7/8	1.08	0.031	1.8555	1.8453	3.2335	3.2232	1.5746	1.5743	3.5436	3.5433

<sup>(1)</sup>Width tolerance of preloaded bearing set +0.000/-0.254 mm (+0.0000/-0.0100 in.).

<sup>(2)</sup>Single bearing.

<sup>(3)</sup>ABMA STD 20 (ras max).

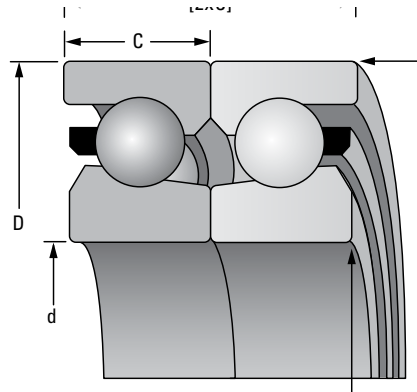

Bearing Number	d Bore	D O.D.	C Width <sup>(1)</sup>	Ball Qty. x Dia.	Wt. <sup>(2)</sup>	r Rad. <sup>(3)</sup>	Suggested Shoulder Diameters				Shaft Dia.		Housing Dia.	
							Shaft		Housing		Max.	Min.	Max.	Min.
							Max.	Min.	Max.	Min.				
mm in.	mm in.	mm in.	mm in.	kg lbs	mm in.	mm in.	mm in.	mm in.	mm in.	mm in.	mm in.	mm in.	mm in.	
MM40BS90-20	<b>40</b> 1.5748	<b>90</b> 3.5433	<b>20</b> 0.7874	<b>24 x 8.7</b> 24 x 1/2	<b>0.660</b> 1.46	<b>0.8</b> 0.031	<b>47.130</b> 1.8555	<b>46.870</b> 1.8453	<b>82.130</b> 3.2335	<b>81.870</b> 3.2232	<b>39.994</b> 1.5746	<b>39.998</b> 1.5743	<b>90.008</b> 3.5436	<b>90.000</b> 3.5433
MM40BS90-23	<b>40</b> 1.5748	<b>90</b> 3.5433	<b>23</b> 0.9055	<b>24 x 8.7</b> 24 x 1/2	<b>0.750</b> 1.65	<b>0.8</b> 0.031	<b>47.130</b> 1.8555	<b>46.870</b> 1.8453	<b>82.130</b> 3.2335	<b>81.870</b> 3.2232	<b>39.994</b> 1.5746	<b>39.988</b> 1.5743	<b>90.008</b> 3.5436	<b>90.000</b> 3.5433
MM40BS100	<b>40</b> 1.5748	<b>100</b> 3.9370	<b>22.5</b> 0.8858	<b>18 x 12.7</b> 18 x 1/2	<b>0.820</b> 1.81	<b>0.8</b> 0.031	<b>47.130</b> 1.8555	<b>46.870</b> 1.8453	<b>90.130</b> 3.5484	<b>89.870</b> 3.5382	<b>39.994</b> 1.5746	<b>39.988</b> 1.5743	<b>100.007</b> 3.9373	<b>100.000</b> 3.9370
MM45BS75	<b>45</b> 1.7717	<b>75</b> 2.9528	<b>15</b> 0.5906	<b>20 x 8.7</b> 20 x 1/2	<b>0.250</b> 0.55	<b>0.8</b> 0.031	<b>52.130</b> 2.0524	<b>51.870</b> 2.0421	<b>69.130</b> 2.7217	<b>68.870</b> 2.7114	<b>44.994</b> 1.7714	<b>44.988</b> 1.7712	<b>75.007</b> 2.9530	<b>75.000</b> 2.9528
MM45BS100	<b>45</b> 1.7717	<b>100</b> 3.9370	<b>22.5</b> 0.8858	<b>18 x 12.7</b> 18 x 1/2	<b>0.760</b> 1.68	<b>0.8</b> 0.031	<b>54.130</b> 2.1311	<b>53.870</b> 2.1209	<b>90.130</b> 3.5484	<b>89.870</b> 3.5382	<b>44.994</b> 1.7714	<b>44.988</b> 1.7712	<b>100.008</b> 3.9373	<b>100.000</b> 3.9370
MM50BS90	<b>50</b> 1.9685	<b>90</b> 3.5433	<b>15</b> 0.5906	<b>24 x 8.7</b> 24 x 1/2	<b>0.410</b> 0.90	<b>0.8</b> 0.031	<b>59.130</b> 2.3280	<b>58.870</b> 2.3177	<b>82.130</b> 3.2335	<b>81.870</b> 3.2232	<b>49.994</b> 1.9683	<b>49.988</b> 1.9680	<b>90.008</b> 3.5436	<b>90.000</b> 3.5433
MM50BS100	<b>50</b> 1.9685	<b>100</b> 3.9370	<b>22.5</b> 0.8858	<b>18 x 12.7</b> 18 x 1/2	<b>0.710</b> 1.57	<b>0.8</b> 0.031	<b>59.130</b> 2.3280	<b>58.870</b> 2.3177	<b>90.130</b> 3.5484	<b>89.870</b> 3.5382	<b>49.994</b> 1.9683	<b>49.988</b> 1.9680	<b>100.008</b> 3.9373	<b>100.000</b> 3.9370
MM55BS90	<b>55</b> 2.1654	<b>90</b> 3.5433	<b>15</b> 0.5906	<b>24 x 8.7</b> 24 x 1/2	<b>0.360</b> 0.79	<b>0.8</b> 0.031	<b>63.130</b> 2.4854	<b>62.870</b> 2.4752	<b>82.130</b> 3.2335	<b>81.870</b> 3.2232	<b>54.993</b> 2.1651	<b>54.986</b> 2.1648	<b>90.008</b> 3.5436	<b>90.000</b> 3.5433
MM55BS120CR <sup>(4)</sup>	<b>55</b> 2.1654	<b>120</b> 4.7244	<b>22.5</b> 0.8858	<b>21 x 12.7</b> 21 x 1/2	<b>1.140</b> 2.51	<b>1.0</b> 0.039	<b>65.130</b> 2.5642	<b>64.870</b> 2.5539	<b>110.130</b> 4.3358	<b>109.870</b> 4.3256	<b>54.993</b> 2.1651	<b>54.986</b> 2.1648	<b>120.008</b> 4.7247	<b>120.000</b> 4.7244
MM60BS120CR <sup>(4)</sup>	<b>60</b> 2.3622	<b>120</b> 4.7244	<b>22.5</b> 0.8858	<b>21 x 12.7</b> 21 x 1/2	<b>1.060</b> 2.34	<b>1.0</b> 0.039	<b>70.130</b> 2.7610	<b>69.870</b> 2.7508	<b>110.130</b> 4.3358	<b>109.870</b> 4.3256	<b>59.993</b> 2.3619	<b>59.986</b> 2.3617	<b>120.008</b> 4.7247	<b>120.000</b> 4.7244
MM75BS110CR <sup>(4)</sup>	<b>75</b> 2.9528	<b>110</b> 4.3307	<b>15</b> 0.5906	<b>30 x 8.7</b> 30 x 1/2	<b>0.460</b> 1.01	<b>0.8</b> 0.031	<b>84.130</b> 3.3122	<b>83.870</b> 3.3020	<b>102.130</b> 4.0209	<b>101.870</b> 4.0106	<b>74.993</b> 2.9525	<b>74.986</b> 2.9522	<b>110.008</b> 4.3310	<b>110.000</b> 4.3307
MM100BS150CR <sup>(4)</sup>	<b>100</b> 3.9370	<b>150</b> 5.9055	<b>22.5</b> 0.8858	<b>26 x 12.7</b> 26 x 1/2	<b>1.280</b> 2.82	<b>1.0</b> 0.039	<b>110.130</b> 4.3358	<b>109.870</b> 4.3256	<b>138.130</b> 5.4382	<b>137.870</b> 5.4280	<b>99.992</b> 3.9367	<b>99.984</b> 3.9364	<b>150.009</b> 5.9059	<b>150.000</b> 5.9055

<sup>(1)</sup>Width tolerance of preloaded bearing set +0.000/-0.254 mm (+0.0000/-0.0100 in.).

<sup>(2)</sup>Single bearing.

<sup>(3)</sup>ABMA STD 20 (ras max).

<sup>(4)</sup>CR indicates phenolic cage design.

### INCH SERIES

- Designed for maximum axial rigidity, low drag torque, and extreme control of lateral eccentricity.
- Manufactured to ABEC 9/ISO P2 axial tolerances.
- Nonseparable angular-contact type design (60° contact angle).
- Manufactured to ABEC 7/ISO P4 radial and envelope tolerances.
- Maximum complement of balls.
- Supplied prelubricated with heavy-duty grease NLGI #2.
- Packaged in DB arrangement [can be mounted in duplexed pairs and in multiplexed sets in either back-to-back (DB), face-to-face (DF) or tandem (DT) arrangements]

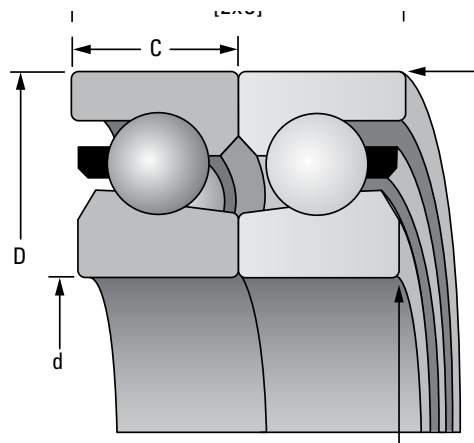

Bearing Number	d Bore	D O.D.	C Width <sup>(1)</sup>	Ball Qty. x Dia.	Wt. <sup>(2)</sup>	r Rad. <sup>(3)</sup>	Suggested Shoulder Diameters				Shaft Dia.		Housing Dia.	
							Shaft		Housing		Max.	Min.	Max.	Min.
							Max.	Min.	Max.	Min.				
mm in.	mm in.	mm in.	mm in.	mm in.	kg lbs	mm in.	mm in.	mm in.	mm in.	mm in.	mm in.	mm in.	mm in.	
MM9306WI2H	20 0.7874	47 1.8504	15.88 0.6250	12 x 7.9 12 x 5/16	0.130 0.28	0.8 0.031	27.508 1.0830	27.254 1.0730	41.681 1.6410	41.427 1.6310	19.995 0.7872	19.990 0.7870	47.008 1.8507	47.000 1.8504
MM9308WI2H	23.8 0.9385	62 2.4409	15.88 0.6250	17 x 7.9 17 x 5/16	0.250 0.56	0.8 0.031	33.553 1.3210	33.299 1.3110	55.347 2.1790	55.093 2.1690	23.833 0.9383	23.828 0.9381	62.006 2.4412	61.999 2.4409
MM9310WI2H	38.1 1.5000	72 2.8346	15.88 0.6250	18 x 8.7 18 x 1/2	0.280 0.62	0.8 0.031	47.371 1.8650	47.117 1.8550	62.967 2.4790	62.713 2.4690	38.092 1.4997	38.085 1.4994	72.006 2.8349	71.999 2.8346
MM9311WI3H	44.5 1.7510	76.2 3.0000	15.88 0.6250	20 x 8.7 20 x 1/2	0.290 0.63	0.8 0.031	52.248 2.0570	51.994 2.0470	67.869 2.6720	67.615 2.6620	44.468 1.7507	44.460 1.7504	76.208 3.0003	76.200 3.0000
MM9313WI5H	57.2 2.2500	90 3.5433	15.88 0.6250	24 x 8.7 24 x 1/2	0.360 0.80	0.8 0.031	65.456 2.5770	65.202 2.5670	81.178 3.1960	80.924 3.1860	57.142 2.2497	57.135 2.2494	90.007 3.5436	90.000 3.5433
MM9316WI3H	76.2 3.0000	110 4.3307	15.88 0.6250	30 x 8.7 30 x 1/2	0.470 1.04	0.8 0.031	85.852 3.3800	85.598 3.3700	101.600 4.0000	101.346 3.9900	76.192 2.9997	76.185 2.9994	110.007 4.3310	110.000 4.3307
MM9321WI3H	101.6 4.0000	145 5.7087	22.23 0.8750	37 x 9.5 37 x 3/8	1.180 2.60	1.0 0.039	112.217 4.4180	111.963 4.4080	134.645 5.3010	134.391 5.2910	101.592 3.9997	101.585 3.9994	145.011 5.7091	145.001 5.7087
MM9326WI6H	127 5.0000	180 7.0866	22.23 0.8750	35 x 12.7 35 x 1/2	1.750 3.85	1.0 0.039	143.993 5.6690	143.739 5.6590	167.919 6.6110	167.665 6.6010	126.992 4.9997	126.985 4.9994	180.010 7.0870	180.000 7.0866

<sup>(1)</sup>Width tolerance of preloaded bearing set +0.000/-0.254 mm (+0.0000/-0.0100 in.).

<sup>(2)</sup>Single bearing.

<sup>(3)</sup>ABMA STD 20 (ras max).



**PERFORMANCE DATA**  
**METRIC SERIES**  
**DUH**

Bearing Number	T <sub>L</sub> Static Limiting Thrust Capacity <sup>(3)</sup>	C <sub>ae</sub> Dynamic Axial Load Rating <sup>(1)(3)</sup>	Speed Rating	Axial Spring Constant <sup>(3)</sup>	Drag Torque (Preloaded Set)	Preload <sup>(2)(3)</sup> (Heavy)
	N lbs.	N lbs.	RPM	N/μm 10 <sup>6</sup> lbs./in	N-m lbs.-in.	N lbs.
MM12BS32DUH	<b>17260</b>	<b>9500</b>	<b>7300</b>	<b>425</b>	<b>0.28</b>	<b>1000</b>
	3880	2140	7300	2.4	2.48	200
MM15BS35DUH	<b>20900</b>	<b>10400</b>	<b>6400</b>	<b>490</b>	<b>0.30</b>	<b>1200</b>
	4700	2340	6400	2.8	2.65	300
MM17BS47DUH	<b>48740</b>	<b>24900</b>	<b>4700</b>	<b>750</b>	<b>0.32</b>	<b>3110</b>
	10960	5600	4700	4.3	2.83	700
MM20BS47DUH	<b>48740</b>	<b>24900</b>	<b>4700</b>	<b>750</b>	<b>0.32</b>	<b>3110</b>
	10960	5600	4700	4.3	2.83	700
MM25BS52DUH	<b>54020</b>	<b>26000</b>	<b>4300</b>	<b>780</b>	<b>0.39</b>	<b>2700</b>
	12140	5850	4300	4.5	3.45	600
MM25BS62DUH	<b>74130</b>	<b>29800</b>	<b>3300</b>	<b>1050</b>	<b>0.44</b>	<b>4450</b>
	16670	6700	3300	6.0	3.88	1000
MM30BS62DUH	<b>74130</b>	<b>29800</b>	<b>3300</b>	<b>1050</b>	<b>0.44</b>	<b>4450</b>
	16670	6700	3300	6.0	3.88	1000
MM30BS72DUH	<b>95470</b>	<b>36300</b>	<b>2900</b>	<b>1260</b>	<b>0.44</b>	<b>6230</b>
	21460	8160	2900	7.2	3.88	1400
MM35BS72DUH	<b>95470</b>	<b>36300</b>	<b>2900</b>	<b>1260</b>	<b>0.44</b>	<b>6230</b>
	21460	8160	2900	7.2	3.88	1400
MM40BS72DUH	<b>95470</b>	<b>36300</b>	<b>2900</b>	<b>1260</b>	<b>0.44</b>	<b>6230</b>
	21460	8160	2900	7.2	3.88	1400
MM45BS75DUH	<b>107170</b>	<b>38500</b>	<b>2700</b>	<b>1380</b>	<b>0.56</b>	<b>6670</b>
	24090	8660	2700	7.9	4.96	1500
MM40BS90DUH	<b>126090</b>	<b>41400</b>	<b>2200</b>	<b>1660</b>	<b>0.82</b>	<b>8010</b>
	28350	9310	2200	9.5	7.26	1800
MM40BS90-20DUH	<b>126090</b>	<b>41400</b>	<b>2200</b>	<b>1660</b>	<b>0.82</b>	<b>8010</b>
	28350	9310	2200	9.5	7.26	1800
MM40BS90-23DUH	<b>126090</b>	<b>41400</b>	<b>2200</b>	<b>1660</b>	<b>0.82</b>	<b>8010</b>
	28350	9310	2200	9.5	7.26	1800
MM50BS90DUH	<b>126090</b>	<b>41400</b>	<b>2200</b>	<b>1660</b>	<b>0.82</b>	<b>8010</b>
	28350	9310	2200	9.5	7.26	1800
MM55BS90DUH	<b>126090</b>	<b>41400</b>	<b>2200</b>	<b>1660</b>	<b>0.82</b>	<b>8010</b>
	28350	9310	2200	9.5	7.26	1800
MM35BS100DUH	<b>202010</b>	<b>71200</b>	<b>2000</b>	<b>1750</b>	<b>1.02</b>	<b>12900</b>
	45410	16010	2000	10.0	9.03	2900
MM40BS100DUH	<b>202010</b>	<b>71200</b>	<b>2000</b>	<b>1750</b>	<b>1.02</b>	<b>12900</b>
	45410	16010	2000	10.0	9.03	2900
MM45BS100DUH	<b>202010</b>	<b>71200</b>	<b>2000</b>	<b>1750</b>	<b>1.02</b>	<b>12900</b>
	45410	16010	2000	10.0	9.03	2900
MM50BS100DUH	<b>202010</b>	<b>71200</b>	<b>2000</b>	<b>1750</b>	<b>1.02</b>	<b>12900</b>
	45410	16010	2000	10.0	9.03	2900
MM75BS110DUH	<b>154590</b>	<b>44500</b>	<b>1700</b>	<b>2080</b>	<b>1.00</b>	<b>9790</b>
	34750	10000	1700	11.9	8.85	2200
MM55BS120DUH	<b>235420</b>	<b>75600</b>	<b>1700</b>	<b>2150</b>	<b>1.36</b>	<b>15570</b>
	52920	17000	1700	12.3	12.04	3500
MM60BS120DUH	<b>235420</b>	<b>75600</b>	<b>1700</b>	<b>2150</b>	<b>1.36</b>	<b>15570</b>
	52920	17000	1700	12.3	12.04	3500
MM100BS150DUH	<b>285470</b>	<b>80900</b>	<b>1300</b>	<b>3400</b>	<b>2.18</b>	<b>21350</b>
	64180	18200	1300	19.4	19.29	4800

<sup>(1)</sup>Based on 1500 hours L<sub>10</sub> life and permissible speed.

<sup>(2)</sup>Heavy preload is standard.

<sup>(3)</sup>Data presented is for a single bearing in a DUH set.

### PERFORMANCE DATA METRIC SERIES QUH

Bearing Number	T <sub>L</sub> Static Limiting Thrust Capacity <sup>(3)</sup>	C <sub>aa</sub> Dynamic Axial Load Rating <sup>(1)(3)</sup>	Speed Rating	Axial Spring Constant <sup>(3)</sup>	Drag Torque (Preloaded Set)	Preload <sup>(2)(3)</sup> (Heavy)
	N lbs.	N lbs.				
MM12BS32QUH	<b>34520</b>	<b>15400</b>	<b>5100</b>	<b>850</b>	<b>0.56</b>	<b>2000</b>
	7760	3500	5100	4.9	4.96	400
MM15BS35QUH	<b>41800</b>	<b>16850</b>	<b>4500</b>	<b>980</b>	<b>0.60</b>	<b>2400</b>
	9400	3800	4500	5.6	5.31	500
MM17BS47QUH	<b>97480</b>	<b>40500</b>	<b>3700</b>	<b>1510</b>	<b>0.64</b>	<b>6230</b>
	21920	9100	3700	8.6	5.65	1400
MM20BS47QUH	<b>97480</b>	<b>40500</b>	<b>3700</b>	<b>1510</b>	<b>0.64</b>	<b>6230</b>
	21920	9100	3700	8.6	5.65	1400
MM25BS52QUH	<b>108040</b>	<b>42300</b>	<b>3700</b>	<b>1560</b>	<b>0.49</b>	<b>5400</b>
	24280	9500	3700	8.9	6.90	1200
MM25BS62QUH	<b>148260</b>	<b>48500</b>	<b>2700</b>	<b>2100</b>	<b>0.88</b>	<b>8900</b>
	33340	10900	2700	12.0	7.78	2000
MM30BS62QUH	<b>148260</b>	<b>48500</b>	<b>2700</b>	<b>2100</b>	<b>0.88</b>	<b>8900</b>
	33340	10900	2700	12.0	7.78	2000
MM30BS72QUH	<b>190940</b>	<b>58700</b>	<b>2100</b>	<b>2520</b>	<b>0.88</b>	<b>12450</b>
	42920	13200	2100	14.4	7.78	2800
MM35BS72QUH	<b>190940</b>	<b>58700</b>	<b>2100</b>	<b>2520</b>	<b>0.88</b>	<b>12450</b>
	42920	13200	2100	14.4	7.78	2800
MM40BS72QUH	<b>190940</b>	<b>58700</b>	<b>2100</b>	<b>2520</b>	<b>0.88</b>	<b>12450</b>
	42920	13200	2100	14.4	7.78	2800
MM45BS75QUH	<b>214340</b>	<b>62700</b>	<b>1800</b>	<b>2770</b>	<b>1.12</b>	<b>13340</b>
	48180	14100	1800	15.8	9.92	3000
MM40BS90QUH	<b>252180</b>	<b>67200</b>	<b>1700</b>	<b>3330</b>	<b>1.64</b>	<b>16010</b>
	56700	15100	1700	19.0	14.51	3600
MM50BS90QUH	<b>252180</b>	<b>67200</b>	<b>1700</b>	<b>3330</b>	<b>1.64</b>	<b>16010</b>
	56700	15100	1700	19.0	14.51	3600
MM55BS90QUH	<b>252180</b>	<b>67200</b>	<b>1700</b>	<b>3330</b>	<b>1.64</b>	<b>16010</b>
	56700	15100	1700	19.0	14.51	3600
MM35BS100QUH	<b>404020</b>	<b>115600</b>	<b>1400</b>	<b>3500</b>	<b>2.04</b>	<b>25800</b>
	90820	26000	1400	20.0	18.05	5800
MM40BS100QUH	<b>404020</b>	<b>115600</b>	<b>1400</b>	<b>3500</b>	<b>2.04</b>	<b>25800</b>
	90820	26000	1400	20.0	18.05	5800
MM45BS100QUH	<b>404020</b>	<b>115600</b>	<b>1400</b>	<b>3500</b>	<b>2.04</b>	<b>25800</b>
	90820	26000	1400	20.0	18.05	5800
MM50BS100QUH	<b>404020</b>	<b>115600</b>	<b>1400</b>	<b>3500</b>	<b>2.04</b>	<b>25800</b>
	90820	26000	1400	20.0	18.05	5800
MM75BS110QUH	<b>309180</b>	<b>72100</b>	<b>1200</b>	<b>4170</b>	<b>2.00</b>	<b>19570</b>
	69500	16200	1200	23.8	17.70	4400
MM55BS120QUH	<b>470840</b>	<b>122800</b>	<b>1200</b>	<b>4310</b>	<b>2.72</b>	<b>31140</b>
	105840	27600	1200	24.6	24.08	7000
MM60BS120QUH	<b>470840</b>	<b>122800</b>	<b>1200</b>	<b>4310</b>	<b>2.72</b>	<b>31140</b>
	105840	27600	1200	24.6	24.08	7000
MM100BS150QUH	<b>570940</b>	<b>131500</b>	<b>900</b>	<b>6790</b>	<b>4.36</b>	<b>42700</b>
	128360	29500	900	38.8	38.59	9600

<sup>(1)</sup>Based on 1500 hours L<sub>10</sub> life and permissible speed.

<sup>(2)</sup>Heavy preload is standard.

<sup>(3)</sup>Data presented is for two bearings in a QUH set mounted DB or DF.

**PERFORMANCE DATA  
INCH SERIES  
DUH/QUH**

Bearing Number	T <sub>L</sub> Static Limiting Thrust Capacity <sup>(3)</sup>	C <sub>ae</sub> Dynamic Axial Load Rating <sup>(1)(3)</sup>	Speed Rating	Axial Spring Constant <sup>(3)</sup>	Drag Torque (Preloaded Set)	Preload <sup>(2)(3)</sup> (Heavy)
	<b>N lbs.</b>	<b>N lbs.</b>	<b>RPM</b>	<b>N/μm 10 lbs./in</b>	<b>N-m lbs.-in.</b>	<b>N lbs.</b>
MM9306W12H DUH	<b>48740</b>	<b>24900</b>	<b>4400</b>	<b>750</b>	<b>0.32</b>	<b>3110</b>
	10960	5600	4400	4.3	2.83	700
MM9308W12H DUH	<b>74130</b>	<b>29800</b>	<b>3200</b>	<b>1050</b>	<b>0.44</b>	<b>4450</b>
	16670	6700	3200	6.0	3.89	1000
MM9310W12H DUH	<b>95470</b>	<b>36300</b>	<b>2500</b>	<b>1260</b>	<b>0.44</b>	<b>6230</b>
	21460	8150	2500	7.2	3.89	1400
MM9311W13H DUH	<b>107090</b>	<b>38500</b>	<b>2100</b>	<b>1380</b>	<b>0.56</b>	<b>6670</b>
	24070	8650	2100	7.9	4.96	1500
MM9313W15H DUH	<b>126090</b>	<b>41400</b>	<b>2000</b>	<b>1660</b>	<b>0.82</b>	<b>8010</b>
	28350	9300	2000	9.5	7.26	1800
MM9316W13H DUH	<b>154460</b>	<b>44500</b>	<b>1400</b>	<b>2080</b>	<b>1.00</b>	<b>9790</b>
	34720	10000	1400	11.9	8.85	2200
MM9321W13 DUH	<b>255160</b>	<b>57400</b>	<b>1000</b>	<b>3400</b>	<b>1.02</b>	<b>21350</b>
	57360	12900	1000	19.4	9.01	4800
MM9326W16H DUH	<b>378120</b>	<b>94300</b>	<b>750</b>	<b>3630</b>	<b>1.26</b>	<b>26690</b>
	85000	21200	750	20.7	11.10	6000
MM9306W12H QUH	<b>97480</b>	<b>40500</b>	<b>3700</b>	<b>1510</b>	<b>0.64</b>	<b>6230</b>
	21920	9100	3700	8.6	5.66	1400
MM9308W12H QUH	<b>148260</b>	<b>48500</b>	<b>2700</b>	<b>2100</b>	<b>0.88</b>	<b>8900</b>
	33340	10900	2700	12.0	7.78	2000
MM9310W12H QUH	<b>190940</b>	<b>58700</b>	<b>2100</b>	<b>2520</b>	<b>0.88</b>	<b>12450</b>
	42920	13200	2100	14.4	7.78	2800
MM9311W13H QUH	<b>214180</b>	<b>62700</b>	<b>1800</b>	<b>2770</b>	<b>1.12</b>	<b>13340</b>
	48140	14100	1800	15.8	9.92	3000
MM9313W15H QUH	<b>252180</b>	<b>67200</b>	<b>1700</b>	<b>3330</b>	<b>1.64</b>	<b>16010</b>
	56700	15100	1700	19.0	14.52	3600
MM9316W13H QUH	<b>308920</b>	<b>72100</b>	<b>1200</b>	<b>4170</b>	<b>2.00</b>	<b>19570</b>
	69440	16200	1200	23.8	17.70	4400
MM9321W13 QUH	<b>510320</b>	<b>93400</b>	<b>900</b>	<b>6800</b>	<b>2.04</b>	<b>42700</b>
	114720	21000	900	38.8	18.02	9600
MM9326W16H QUH	<b>756240</b>	<b>153000</b>	<b>600</b>	<b>7250</b>	<b>2.51</b>	<b>53380</b>
	170000	34400	600	41.4	22.22	12000

<sup>(1)</sup>Based on 1500 hours L<sub>10</sub> life and permissible speed.

<sup>(2)</sup>Heavy preload is standard.

<sup>(3)</sup>Data presented is for two bearings in a QUH set mounted DB or DF.

**BALL SCREW SUPPORT BEARING  
CARTRIDGE UNITS**

**BSBU D – STANDARD AND HEAVY-DUTY  
BEARINGS**

- Designed and developed to give the machine manufacturer a ready-made unit providing excellent stiffness and accuracy in ball screw applications.
- Units combine the features of MM-BS-DU (Duplex) ball screw support bearings with an accurately manufactured housing and laminar ring seals.
- Each unit is prepacked with a measured quantity of high quality bearing grease and requires no further lubrication.
- Units are supplied with the bearings in pairs mounted in the “DB” (“O”) arrangement.
- Other bearing arrangements can be accommodated if required. Please consult your Timken representative with details of your requirements or for suggested shaft and housing fits.
- For load and speed ratings, refer to bearing data on page 197.

**STANDARD SERIES – DIMENSIONAL TOLERANCES ±0.13 mm ( ± 0.005 in.) UNLESS OTHERWISE STATED.**

Shaft Dia.	Unit Number (Bearing Set)	C	d	d <sub>1</sub>	d <sub>2</sub>	d <sub>3</sub>	D	D <sub>1</sub>	D <sub>2</sub>	D <sub>3</sub>	E	F	K	L	N	P	Wt.
mm		mm in.	mm in.	mm in.	mm in.	mm in.	mm in.	mm in.	mm in.	mm in.	mm in.	mm in.	mm in.	mm in.	mm in.	mm in.	kg lbs.
17	BSBU17D60	47.0	17.000 16.996	4.3	6.6	36.0	60.000 59.987	26.0	64.0	90.0	44.26 43.24	42.5	32.0	13.0	76.0	32	1.1
	(MM17BS47DUH)	1.85	0.6693 0.6691	0.17	0.26	1.42	2.3622 2.3617	1.02	2.52	3.54	1.742 1.702	1.67	1.26	0.51	2.99	1.26	2.42
20	BSBU20D60	47.0	20.000 19.996	4.3	6.6	36.0	60.000 59.987	26.0	64.0	90.0	44.26 43.24	42.5	32.0	13.0	76.0	32	1.1
	(MM20BS47DUH)	1.85	0.7874 0.7872	0.17	0.26	1.42	2.3622 2.3617	1.02	2.52	3.54	1.742 1.702	1.67	1.26	0.51	2.99	1.26	2.42
25	BSBU25D80	52.0	25.000 24.996	4.3	9.2	50.0	80.000 79.987	40.0	88.0	120.0	50.26 49.24	59.5	32.0	15.0	102.0	44	2.3
	(MM25BS62DUH)	2.05	0.9842 0.9841	0.17	0.36	1.97	3.1496 3.1491	1.57	3.46	4.72	1.979 1.938	2.34	1.26	0.59	4.02	1.73	5.06
30	BSBU30D80	52.0	30.000 29.996	4.3	9.2	50.0	80.000 79.987	40.0	88.0	120.0	50.26 49.24	59.5	32.0	15.0	102.0	44	2.2
	(MM30BS62DUH)	2.05	1.1811 1.1809	0.17	0.36	1.97	3.1496 3.1491	1.57	3.46	4.72	1.979 1.938	2.34	1.26	0.59	4.02	1.73	4.84
35	BSBU35D90	52.0	35.000 34.995	4.3	9.2	60.0	90.000 89.985	46.0	98.0	130.0	50.26 49.24	66.5	32.0	15.0	113.0	49	3.2
	(MM35BS72DUH)	2.05	1.378 1.3778	0.17	0.36	2.36	3.5433 3.5427	1.81	3.86	5.12	1.979 1.938	2.62	1.26	0.59	4.45	1.93	7.04
40	BSBU40D90	52.0	40.000 39.995	4.3	9.2	60.0	90.000 89.985	46.0	98.0	130.0	50.26 49.24	66.5	32.0	15.0	113.0	49	3.1
	(MM40BS72DUH)	2.05	1.5748 1.5746	0.17	0.36	2.36	3.5433 3.5427	1.81	3.86	5.12	1.979 1.938	2.62	1.26	0.59	4.45	1.93	6.82

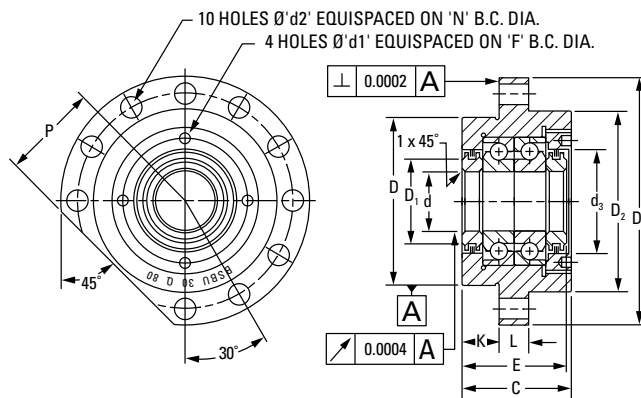

**HEAVY-DUTY SERIES – DIMENSIONAL TOLERANCES ±0.13 mm ( ± 0.005 in.) UNLESS OTHERWISE STATED.**

Shaft Dia.	Unit Number (Bearing Set)	C	d	d <sub>1</sub>	d <sub>2</sub>	d <sub>3</sub>	D	D <sub>1</sub>	D <sub>2</sub>	D <sub>3</sub>	E	F	K	L	N	P	Wt.
mm		mm in.	mm in.	mm in.	mm in.	mm in.	mm in.	mm in.	mm in.	mm in.	mm in.	mm in.	mm in.	mm in.	mm in.	mm in.	kg lbs.
35	BSBU35D124	66.0	35.000 34.995	5.3	11.4	76.0	124.000 123.982	66.0	128.0	165.0	64.26 63.24	90.0	43.5	17.0	146.0	64	6.3
	(MM35BS100DUH)	2.60	1.3780 1.3778	0.21	0.45	2.99	4.8819 4.8812	2.60	5.04	6.50	2.530 2.490	3.54	1.71	0.67	5.75	2.52	13.86
40	BSBU40D124	66.0	40.000 39.995	5.3	11.4	76.0	124.000 123.982	66.0	128.0	165.0	64.26 63.24	90.0	43.5	17.0	146.0	64	6.1
	(MM40BS100DUH)	2.60	1.5748 1.5746	0.21	0.45	2.99	4.8819 4.8812	2.60	5.04	6.50	2.530 2.490	3.54	1.71	0.67	5.75	2.52	13.42
45	BSBU45D124	66.0	45.000 44.995	5.3	11.4	76.0	124.000 123.982	66.0	128.0	165.0	64.26 63.24	90.0	43.5	17.0	146.0	64	6.0
	(MM45BS100DUH)	2.60	1.7716 1.7714	0.21	0.45	2.99	4.8819 4.8812	2.60	5.04	6.50	2.530 2.490	3.54	1.71	0.67	5.75	2.52	13.20
50	BSBU50D124	66.0	50.000 49.995	5.3	11.4	76.0	124.000 123.982	66.0	128.0	165.0	64.26 63.24	90.0	43.5	17.0	146.0	64	5.9
	(MM50BS100DUH)	2.60	1.9685 1.9683	0.21	0.45	2.99	4.8819 4.8812	2.60	5.04	6.50	2.530 2.490	3.54	1.71	0.67	5.75	2.52	12.89

**BALL SCREW SUPPORT BEARING  
CARTRIDGE UNITS**

**BSBU Q – STANDARD  
AND HEAVY-DUTY BEARINGS**

- Similar in design and features to the series BSBU D except MM-BS-QU Quadruplex bearings are used.
- Units are supplied with the bearings in quad sets mounted in the "DB" ("O") arrangement.
- Consult your Timken representative for suggested shaft fits.
- For load and speed ratings, refer to bearing data on page 198.

**STANDARD SERIES – DIMENSIONAL TOLERANCES ±0.13 mm (± 0.005 in.) UNLESS OTHERWISE STATED.**

Shaft Dia.	Unit Number (Bearing Set)	C	d	d <sub>1</sub>	d <sub>2</sub>	d <sub>3</sub>	D	D <sub>1</sub>	D <sub>2</sub>	D <sub>3</sub>	E	F	K	L	N	P	Wt.
mm		mm in.	mm in.	mm in.	mm in.	mm in.	mm in.	mm in.	mm in.	mm in.	mm in.	mm in.	mm in.	mm in.	mm in.	mm in.	kg lbs.
17	BSBU17Q60	77.0	17.000	4.3	6.6	36.0	60.000	26.0	64.0	90.0	74.26	42.5	32.0	13.0	76.0	32.0	1.7
	(MM17BS47QUH)	3.03	16.996 0.6693 0.6690	0.17	0.26	1.42	59.987 2.3622 2.3617	1.02	2.52	3.54	72.74 2.924 2.864	1.67	1.26	0.51	2.99	1.26	3.74
20	BSBU20Q60	77.0	20.000	4.3	6.6	36.0	60.000	26.0	64.0	90.0	74.26	42.5	32.0	13.0	76.0	32.0	1.7
	(MM20BS47QUH)	3.03	19.996 0.7874 0.7872	0.17	0.26	1.42	59.987 2.3622 2.3617	1.02	2.52	3.54	72.74 2.924 2.864	1.67	1.26	0.51	2.99	1.26	3.74
25	BSBU25Q80	82.0	25.000	4.3	9.2	50.0	80.000	40.0	88.0	120.0	80.26	59.5	32.0	15.0	102.0	44.0	3.5
	(MM25BS62QUH)	3.23	24.996 0.9842 0.9841	0.17	0.36	1.97	79.987 3.1496 3.1491	1.57	3.46	4.72	78.74 3.160 3.100	2.34	1.26	0.59	4.02	1.73	7.70
30	BSBU30Q80	82.0	30.000	4.3	9.2	50.0	80.000	40.0	88.0	120.0	80.26	59.5	32.0	15.0	102.0	44.0	3.4
	(MM30BS62QUH)	3.23	29.996 1.1811 1.1809	0.17	0.36	1.97	79.987 3.1496 3.1491	1.57	3.46	4.72	78.74 3.160 3.100	2.34	1.26	0.59	4.02	1.73	7.48
35	BSBU35Q90	82.0	35.000	4.3	9.2	60.0	90.000	46.0	98.0	130.0	80.26	66.5	32.0	15.0	113.0	49.0	4.6
	(MM35BS72QUH)	3.23	34.995 1.3780 1.3778	0.17	0.36	2.36	89.985 3.5433 3.5427	1.81	3.86	5.12	78.74 3.160 3.100	2.62	1.26	0.59	4.45	1.93	10.12
40	BSBU40Q90	82.0	40.000	4.3	9.2	60.0	90.000	46.0	98.0	130.0	80.26	66.5	32.0	15.0	113.0	49.0	4.5
	(MM40BS72QUH)	3.23	39.995 1.5748 1.5746	0.17	0.36	2.36	89.985 3.5433 3.5427	1.81	3.86	5.12	78.74 3.160 3.100	2.62	1.26	0.59	4.45	1.93	9.90

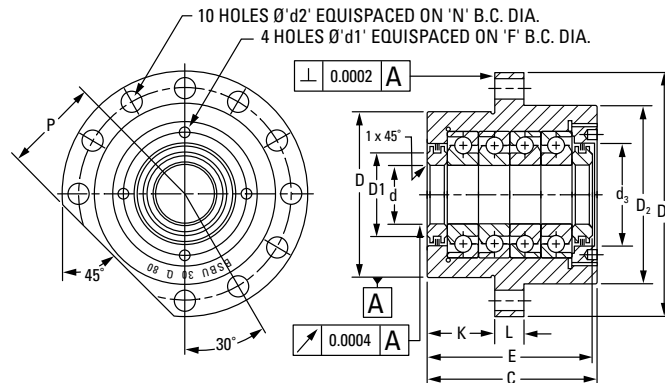

**HEAVY-DUTY SERIES – DIMENSIONAL TOLERANCES ±0.13 mm ( ± 0.005 in.) UNLESS OTHERWISE STATED.**

Shaft Dia.	Unit Number (Bearing Set)	C	d	d <sub>1</sub>	d <sub>2</sub>	d <sub>3</sub>	D	D <sub>1</sub>	D <sub>2</sub>	D <sub>3</sub>	E	F	K	L	N	P	Wt.
mm		mm in.	mm in.	mm in.	mm in.	mm in.	mm in.	mm in.	mm in.	mm in.	mm in.	mm in.	mm in.	mm in.	mm in.	mm in.	kg lbs.
35	BSBU35Q124	106.0	35.000 34.995	5.3	11.4	76.0	124.000 123.982	66.0	128.0	165.0	104.26 102.74	90.0	43.5	17.0	146.0	64.0	10.1
	(MM35BS100QUH)	4.17	1.3780 1.3778	0.21	0.45	2.99	4.8819 4.8812	2.60	5.04	6.50	4.105 4.045	3.54	1.71	0.67	5.75	2.52	22.22
40	BSBU40Q124	106.0	40.000 39.995	5.3	11.4	76.0	124.000 123.982	66.0	128.0	165.0	104.26 102.74	90.0	43.5	17.0	146.0	64.0	9.7
	(MM40BS100QUH)	4.17	1.5748 1.5746	0.21	0.45	2.99	4.8819 4.8812	2.60	5.04	6.50	4.105 4.045	3.54	1.71	0.67	5.75	2.52	21.34
45	BSBU45Q124	106.0	45.000 44.995	5.3	11.4	76.0	124.000 123.982	66.0	128.0	165.0	104.26 102.74	90.0	43.5	17.0	146.0	64.0	9.5
	(MM45BS100QUH)	4.17	1.7716 1.7714	0.21	0.45	2.99	4.8819 4.8812	2.60	5.04	6.50	4.105 4.045	3.54	1.71	0.67	5.75	2.52	20.90
50	BSBU50Q124	106.0	50.000 49.995	5.3	11.4	76.0	124.000 123.982	66.0	128.0	165.0	104.26 102.74	90.0	43.5	17.0	146.0	64.0	9.3
	(MM50BS100QUH)	4.17	1.9685 1.9683	0.21	0.45	2.99	4.8819 4.8812	2.60	5.04	6.50	4.105 4.045	3.54	1.71	0.67	5.75	2.52	20.46

**BALL SCREW SUPPORT BEARING  
PILLOW BLOCK UNITS**

**BSPB D – STANDARD  
AND HEAVY-DUTY BEARINGS**

- Designed for ball screw applications.
- Incorporates similar features to the series BSBU D but is designed to bolt down onto a flat surface, parallel to the ball screw axis.
- In the standard unit, pilot holes for dowels are provided.
- Units are supplied with the bearings in duplex sets mounted in the "DB" ("O") arrangement.
- Units with finished holes for dowels can be supplied by special order if required.
- Consult your Timken representative for suggested shaft fits.
- For load and speed ratings, refer to bearing data on page 197.

**STANDARD SERIES – DIMENSIONAL TOLERANCES ±0.13 mm ( ± 0.005 in.) UNLESS OTHERWISE STATED.**

Shaft Dia.	Unit Number (Bearing Set)	C	d	d <sub>1</sub>	d <sub>2</sub>	d <sub>3</sub>	d <sub>4</sub>	D	E	F	G	H	J	K	L	N	P	R	S	T	U	Wt.
mm		mm in.	mm in.	mm in.	mm in.	mm in.	mm in.	mm in.	mm in.	mm in.	mm in.	mm in.	mm in.	mm in.	mm in.	mm in.	mm in.	mm in.	mm in.	mm in.	mm in.	kg lbs.
17	BSPB17D32	47.000	17.000	4.3	7.8	9.0	36.0	26.0	44.26	42.5	47.000	17	62	32.0	1.0	32.000	38.0	22.0	9.0	8.5	85.5	1.5
		46.950	16.996						43.24		46.987					31.987						
	(MM17BS47DUH)	1.850 1.848	0.6693 0.6691	0.17	0.31	0.35	1.42	1.02	1.742 1.702	1.67	1.8504 1.8499	0.67	2.44	1.26	0.04	1.2598 1.2593	1.50	0.87	0.35	0.33	3.37	3.30
20	BSPB20D32	47.000	20.000	4.3	7.8	9.0	36.0	26.0	44.26	42.5	47.000	17	62	32.0	1.0	32.000	38.0	22.0	9.0	8.5	85.5	1.5
		46.950	19.996						43.24		46.987					31.987						
	(MM20BS47DUH)	1.850 1.848	0.7874 0.7872	0.17	0.31	0.35	1.42	1.02	1.742 1.702	1.67	1.8504 1.8499	0.67	2.44	1.26	0.04	1.2598 1.2593	1.50	0.87	0.35	0.33	3.37	3.30
25	BSPB25D42	52.000	25.000	4.3	9.8	11.0	50.0	40.0	50.26	59.5	62.500	20	85	42.0	1.0	42.000	42.0	25.0	10.0	10.0	115.0	2.8
		51.950	24.996						49.24		62.487					41.987						
	(MM25BS62DUH)	2.047 2.045	0.9842 0.9841	0.17	0.39	0.43	1.97	1.57	1.979 1.938	2.34	2.4606 2.4601	0.79	3.35	1.65	0.04	1.6535 1.6530	1.65	0.98	0.39	0.39	4.53	6.16
30	BSPB30D42	52.000	30.000	4.3	9.8	11.0	50.0	40.0	50.26	59.5	62.500	20	85	42.0	1.0	42.000	42.0	25.0	10.0	10.0	115.0	2.7
		51.920	29.996						49.24		62.487					41.987						
	(MM30BS62DUH)	2.047 2.045	1.1811 1.1809	0.17	0.39	0.43	1.97	1.57	1.979 1.938	2.34	2.4606 2.4601	0.79	3.35	1.65	0.04	1.6535 1.6530	1.65	0.98	0.39	0.39	4.53	5.94
35	BSPB35D50	52.000	35.000	4.3	13.0	13.0	60.0	46.0	50.26	66.5	68.000	20.5	95	50	1.0	50.000	42.0	25.0	10.0	10.0	126.0	3.8
		51.950	34.995						49.24		67.987					49.987						
	(MM35BS72DUH)	2.047 2.045	1.3780 1.3778	0.17	0.51	0.51	2.36	1.81	1.979 1.938	2.62	2.6772 2.6767	0.81	3.74	1.97	0.04	1.9685 1.9680	1.65	0.98	0.39	0.39	4.96	8.36
40	BSPB40D50	52.000	40.000	4.3	13.0	13.0	60.0	46.0	50.26	66.5	68.000	20.5	95	50.0	1.0	50.000	42.0	25.0	10.0	10.0	126.0	3.7
		51.950	39.995						49.24		67.987					49.987						
	(MM40BS72DUH)	2.047 2.045	1.5748 1.5746	0.17	0.51	0.51	2.36	1.81	1.979 1.938	2.62	2.6772 2.6767	0.81	3.74	1.97	0.04	1.9685 1.9680	1.65	0.98	0.39	0.39	4.96	8.14



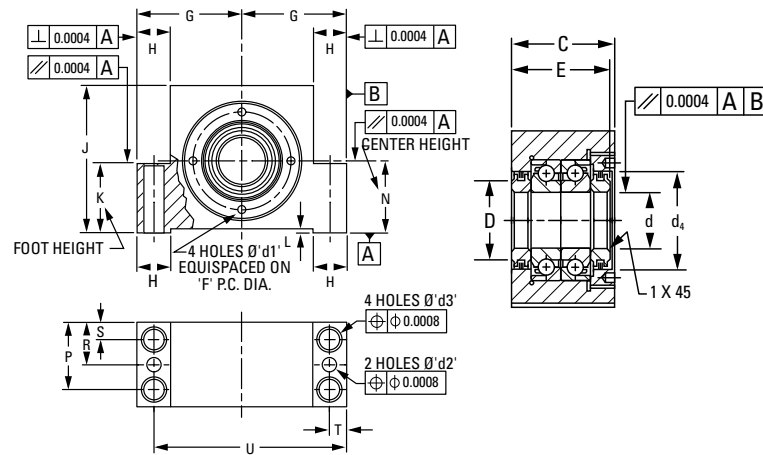

**HEAVY-DUTY SERIES – DIMENSIONAL TOLERANCES ±0.13 mm ( ± 0.005 in.) UNLESS OTHERWISE STATED.**

Shaft Dia.	Unit Number (Bearing Set)	C	d	d <sub>1</sub>	d <sub>2</sub>	d <sub>3</sub>	d <sub>4</sub>	D	E	F	G	H	J	K	L	N	P	R	S	T	U	Wt.
mm		mm in.	mm in.	mm in.	mm in.	mm in.	mm in.	mm in.	mm in.	mm in.	mm in.	mm in.	mm in.	mm in.	mm in.	mm in.	mm in.	mm in.	mm in.	mm in.	mm in.	kg lbs.
35	BSPB35D65	66.000	35.000	5.3	11.8	18.0	76.0	66.0	64.26	90.0	95.000	30.0	130.0	65.0	1.0	65.000	53.0	32.0	13.0	15.0	175.0	9.7
		65.950	34.995						63.24		94.987					64.987						
	(MM35BS100DUH)	2.598	1.3780	0.21	0.46	0.71	2.99	2.60	2.530	3.54	3.7402	1.18	5.12	2.56	0.04	2.5590	2.09	1.26	0.51	0.59	6.89	21.34
		2.596	1.3778						2.490		3.7396					2.5585						
40	BSPB40D65	66.000	40.000	5.3	11.8	18.0	76.0	66.0	64.26	90.0	95.000	30.0	130.0	65.0	1.0	65.000	53.0	32.0	13.0	15.0	175.0	9.5
		65.950	39.995						63.24		94.987					64.987						
	(MM40BS100DUH)	2.598	1.5748	0.21	0.46	0.71	2.99	2.60	2.530	3.54	3.7402	1.18	5.12	2.56	0.04	2.5590	2.09	1.26	0.51	0.59	6.89	20.90
		2.596	1.5746						2.490		3.7396					2.5585						
45	BSPB45D65	66.000	45.000	5.3	11.8	18.0	76.0	66.0	64.26	90.0	95.000	30.0	130.0	65.0	1.0	65.000	53.0	32.0	13.0	15.0	175.0	9.3
		65.950	44.995						63.24		94.987					64.987						
	(MM45BS100DUH)	2.598	1.7716	0.21	0.46	0.71	2.99	2.60	2.530	3.54	3.7402	1.18	5.12	2.56	0.04	2.5590	2.09	1.26	0.51	0.59	6.89	20.46
		2.596	1.7714						2.490		3.7396					2.5585						
50	BSPB50D65	66.000	50.000	5.3	11.8	18.0	76.0	66.0	64.26	90.0	95.000	30.0	130.0	65.0	1.0	65.000	53.0	32.0	13.0	15.0	175.0	9.1
		65.950	49.995						63.24		94.987					64.987						
	(MM50BS100DUH)	2.598	1.9685	0.21	0.46	0.71	2.99	2.60	2.530	3.54	3.7402	1.18	5.12	2.56	0.04	2.5590	2.09	1.26	0.51	0.59	6.89	20.02
		2.596	1.9683						2.490		3.7396					2.5585						

**BALL SCREW SUPPORT BEARING  
PILLOW BLOCK UNITS**

**BSPB Q – STANDARD  
AND HEAVY-DUTY BEARINGS**

- Similar in design and features to the Series BSPB D, except MM-BS-QU Quadruplex bearings are used.
- Units are supplied with the bearings in quad sets mounted in the "DB" ("O") arrangement.
- Consult your Timken representative for suggested shaft fits.
- For load and speed ratings, refer to bearing data on page 198.

**STANDARD SERIES – DIMENSIONAL TOLERANCES ±0.13 mm ( ± 0.005 in.) UNLESS OTHERWISE STATED.**

Shaft Dia.	Unit Number (Bearing Set)	C	d	d <sub>1</sub>	d <sub>2</sub>	d <sub>3</sub>	d <sub>4</sub>	D	E	F	G	H	J	K	L	N	P	R	S	T	U	Wt.	
mm		mm in.	mm in.	mm in.	mm in.	mm in.	mm in.	mm in.	mm in.	mm in.	mm in.	mm in.	mm in.	mm in.	mm in.	mm in.	kg lbs.	mm in.	mm in.	mm in.	mm in.	mm in.	kg lbs.
17	BSPB17Q32	<b>77.00</b>	<b>17.000</b>	<b>4.3</b>	<b>7.8</b>	<b>9.0</b>	<b>36.0</b>	<b>26.0</b>	<b>74.26</b>	<b>42.5</b>	<b>47.000</b>	<b>17</b>	<b>62</b>	<b>32.0</b>	<b>1.0</b>	<b>32.000</b>	<b>68.0</b>	<b>22.0</b>	<b>9.0</b>	<b>8.5</b>	<b>85.5</b>	<b>2.6</b>	
		<b>76.95</b>	<b>16.996</b>						<b>72.74</b>		<b>46.987</b>					<b>31.987</b>							
	(MM17BS47QUH)	3.031 3.03	0.6693 0.6691	0.17	0.31	0.35	1.42	1.02	2.924 2.864	1.67	1.8504 1.8499	0.67	2.44	1.26	0.04	1.2598 1.2593	2.68	0.87	0.35	0.33	3.37	5.72	
20	BSPB20Q32	<b>77.00</b>	<b>20.000</b>	<b>4.3</b>	<b>7.8</b>	<b>9.0</b>	<b>36.0</b>	<b>26.0</b>	<b>74.26</b>	<b>42.5</b>	<b>47.000</b>	<b>17</b>	<b>62</b>	<b>32.0</b>	<b>1.0</b>	<b>32.000</b>	<b>68.0</b>	<b>22.0</b>	<b>9.0</b>	<b>8.5</b>	<b>85.5</b>	<b>2.5</b>	
		<b>76.95</b>	<b>19.996</b>						<b>72.74</b>		<b>46.987</b>					<b>31.987</b>							
	(MM20BS47QUH)	3.031 3.03	0.7874 0.7872	0.17	0.31	0.35	1.42	1.02	2.924 2.864	1.67	1.8504 1.8499	0.67	2.44	1.26	0.04	1.2598 1.2593	2.68	0.87	0.35	0.33	3.37	5.50	
25	BSPB25Q42	<b>82.00</b>	<b>25.000</b>	<b>4.3</b>	<b>9.8</b>	<b>11.0</b>	<b>50.0</b>	<b>40.0</b>	<b>80.26</b>	<b>59.5</b>	<b>62.500</b>	<b>20</b>	<b>85</b>	<b>42.0</b>	<b>1.0</b>	<b>42.000</b>	<b>72.0</b>	<b>25.0</b>	<b>10.0</b>	<b>10.0</b>	<b>115.0</b>	<b>4.6</b>	
		<b>81.95</b>	<b>24.996</b>						<b>78.74</b>		<b>62.487</b>					<b>41.987</b>							
	(MM25BS62QUH)	3.228 3.226	0.9842 0.9841	0.17	0.39	0.43	1.97	1.57	3.160 3.100	2.34	2.4606 2.4601	0.79	3.35	1.65	0.04	1.6535 1.6530	2.68	0.98	0.39	0.39	4.53	10.12	
30	BSPB30Q42	<b>82.00</b>	<b>30.000</b>	<b>4.3</b>	<b>9.8</b>	<b>11.0</b>	<b>50.0</b>	<b>40.0</b>	<b>80.26</b>	<b>59.5</b>	<b>62.500</b>	<b>20</b>	<b>85</b>	<b>42.0</b>	<b>1.0</b>	<b>42.000</b>	<b>72.0</b>	<b>25.0</b>	<b>10.0</b>	<b>10.0</b>	<b>115.0</b>	<b>4.5</b>	
		<b>81.95</b>	<b>29.996</b>						<b>78.74</b>		<b>62.487</b>					<b>41.987</b>							
	(MM30BS62QUH)	3.228 3.226	1.1811 1.1809	0.17	0.39	0.43	1.97	1.57	3.160 3.100	2.34	2.4606 2.4601	0.79	3.35	1.65	0.04	1.6535 1.6530	2.68	0.98	0.39	0.39	4.53	9.90	
35	BSPB35Q50	<b>82.00</b>	<b>35.000</b>	<b>4.3</b>	<b>13.0</b>	<b>13.0</b>	<b>60.0</b>	<b>46.0</b>	<b>80.26</b>	<b>66.5</b>	<b>68.000</b>	<b>20.5</b>	<b>95</b>	<b>50</b>	<b>1.0</b>	<b>50.000</b>	<b>72.0</b>	<b>25.0</b>	<b>10.0</b>	<b>10.0</b>	<b>126.0</b>	<b>6.2</b>	
		<b>81.95</b>	<b>34.995</b>						<b>78.74</b>		<b>67.987</b>					<b>49.987</b>							
	(MM35BS72QUH)	3.228 3.226	1.3780 1.3778	0.17	0.51	0.51	2.36	1.81	3.160 3.100	2.62	2.6772 2.6767	0.81	3.74	1.97	0.04	1.9685 1.9680	2.68	0.98	0.39	0.39	4.96	13.64	
40	BSPB40Q50	<b>82.00</b>	<b>40.000</b>	<b>4.3</b>	<b>13.0</b>	<b>13.0</b>	<b>60.0</b>	<b>46.0</b>	<b>80.26</b>	<b>66.5</b>	<b>68.000</b>	<b>20.5</b>	<b>95</b>	<b>50.0</b>	<b>1.0</b>	<b>50.000</b>	<b>72.0</b>	<b>25.0</b>	<b>10.0</b>	<b>10.0</b>	<b>126.0</b>	<b>6.0</b>	
		<b>81.95</b>	<b>39.995</b>						<b>78.74</b>		<b>67.987</b>					<b>49.987</b>							
	(MM40BS72QUH)	3.228 3.226	1.5748 1.5746	0.17	0.51	0.51	2.36	1.81	4.105 4.045	2.62	2.6772 2.6767	0.81	3.74	1.97	0.04	1.9685 1.9680	2.68	0.98	0.39	0.39	4.96	13.20	

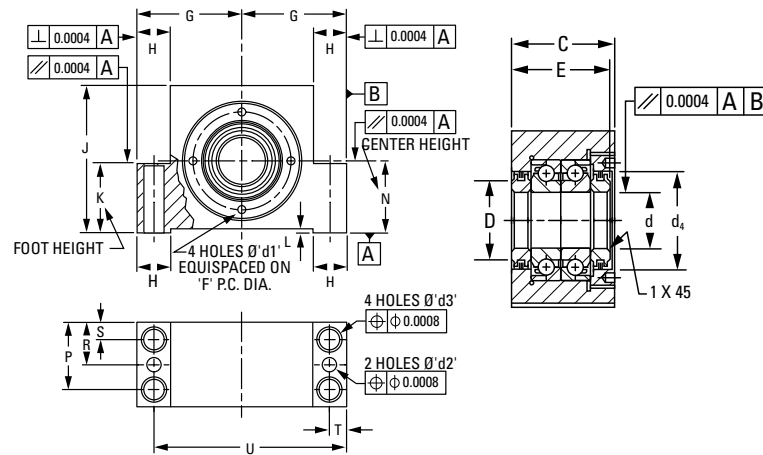

**HEAVY-DUTY SERIES – DIMENSIONAL TOLERANCES  $\pm 0.13$  mm ( $\pm 0.005$  in.) UNLESS OTHERWISE STATED.**

Shaft Dia.	Unit Number (Bearing Set)	C	d	d <sub>1</sub>	d <sub>2</sub>	d <sub>3</sub>	d <sub>4</sub>	D	E	F	G	H	J	K	L	N	P	R	S	T	U	Wt.	
mm		mm in.	mm in.	mm in.	mm in.	mm in.	mm in.	mm in.	mm in.	mm in.	mm in.	mm in.	mm in.	mm in.	mm in.	mm in.	kg lbs.	mm in.	mm in.	mm in.	mm in.	mm in.	kg lbs.
35	BSPB35D65	106.00	35.000	5.3	11.8	18.0	76.0	66.0	104.26	90.0	95.000	30.0	130.0	65.0	1.0	65.000	93.0	32.0	13.0	15.0	175.0	15.9	
		105.95	34.995						102.74		94.987					64.987							
	(MM35BS100QUH)	4.173	1.3780	0.21	0.46	0.71	2.99	2.60	3.160	3.54	3.7402	1.18	5.12	2.56	0.04	2.5590	3.66	1.26	0.51	0.59	6.89	34.98	
		4.171	1.3778						3.100		3.7396					2.5585							
40	BSPB40Q65	106.00	40.000	5.3	11.8	18.0	76.0	66.0	104.26	90.0	95.000	30.0	130.0	65.0	1.0	65.000	93.0	32.0	13.0	15.0	175.0	15.7	
		105.95	39.995						102.74		94.987					64.987							
	(MM40BS100QUH)	4.173	1.5748	0.21	0.46	0.71	2.99	2.60	4.105	3.54	3.7402	1.18	5.12	2.56	0.04	2.5590	3.66	1.26	0.51	0.59	6.89	34.54	
		4.171	1.5746						4.045		3.7396					2.5585							
45	BSPB45Q65	106.00	45.000	5.3	11.8	18.0	76.0	66.0	104.26	90.0	95.000	30.0	130.0	65.0	1.0	65.000	93.0	32.0	13.0	15.0	175.0	15.4	
		105.95	44.995						102.74		94.987					64.987							
	(MM45BS100QUH)	4.173	1.7716	0.21	0.46	0.71	2.99	2.60	4.105	3.54	3.7402	1.18	5.12	2.56	0.04	2.5590	3.66	1.26	0.51	0.59	6.89	33.88	
		4.171	1.7714						4.045		3.7396					2.5585							
50	BSPB50Q65	106.00	50.000	5.3	11.8	18.0	76.0	66.0	104.26	90.0	95.000	30.0	130.0	65.0	1.0	65.000	93.0	32.0	13.0	15.0	175.0	15.1	
		105.95	49.995						102.74		94.987					64.987							
	(MM50BS100QUH)	4.173	1.9685	0.21	0.46	0.71	2.99	2.60	4.105	3.54	3.7402	1.18	5.12	2.56	0.04	2.5590	3.66	1.26	0.51	0.59	6.89	33.22	
		4.171	1.9683						4.045		3.7396					2.5585							

**BALL SCREW SUPPORT BEARINGS  
SEALED, DOUBLE-ROW FLANGED STYLE  
MMF SERIES**

- Specifically designed for ball screw applications.
- Integral double-row design supports axial and combined loads.
- Nominal contact angle 60 degrees for superior axial rigidity and accuracy.
- Low torque, integral contact seals.
- Easy and flexible installation without external clamping.
- Sealed duplex configuration standard with optional seals, shields, ceramic balls and quadruplex sets available.

Bearing Number	d Bore	D O.D.	C Width	Wt.	Capacity		Speed Rating	Radius		D <sub>1</sub> Min.	d <sub>1</sub> Max.
					C Dynamic	C <sub>0a</sub> Static		r <sub>1</sub> Outer	r Inner		
<b>METRIC</b>	<b>mm +0/- (µm)</b>	<b>mm +0/- (µm)</b>	<b>mm +0/- (µm)</b>	<b>kg</b>	<b>N</b>	<b>N</b>	<b>mm</b>	<b>mm</b>	<b>mm</b>	<b>mm</b>	<b>mm</b>
MMF512BS55PP DM	12 (3.8)	55 (7.6)	25 (254)	0.40	15300	26970	4700	0.6	0.3	33.1	25.0
MMF515BS60PP DM	15 (3.8)	60 (7.6)	25 (254)	0.47	16100	30350	4290	0.6	0.3	37.0	27.6
MMF517BS62PP DM	17 (3.8)	62 (7.6)	25 (254)	0.49	16800	33570	4000	0.6	0.3	37.8	28.4
MMF520BS68PP DM	20 (5.1)	68 (7.6)	28 (254)	0.64	21800	46360	3400	0.6	0.3	43.2	34.5
MMF525BS75PP DM	25 (5.1)	75 (7.6)	28 (254)	0.76	23200	54980	2900	0.6	0.3	49.5	40.6
MMF530BS80PP DM	30 (5.1)	80 (7.6)	28 (254)	0.84	24500	63370	2600	0.6	0.3	54.3	45.6
MMF540BS100PP DM	40 (6.4)	100 (7.6)	34 (254)	1.50	36300	98980	2070	0.6	0.3	68.7	57.5
MMF550BS115PP DM	50 (6.4)	115 (7.6)	34 (254)	1.37	40500	131950	1670	0.6	0.3	82.6	71.5
MMF550BS140PP DM	50 (6.4)	140 (8.9)	54 (254)	4.89	95400	249080	1460	0.6	0.6	99.6	81.1
MMF560BS145PP DM	60 (7.6)	145 (8.9)	45 (254)	4.28	71200	213110	1400	0.6	0.6	100.0	89.0
<b>INCH</b>	<b>in. +0/- (x)</b>	<b>in. +0/- (x)</b>	<b>in. +0/- (x)</b>	<b>lbs.</b>	<b>lbs.</b>	<b>lbs.</b>	<b>in.</b>	<b>in.</b>	<b>in.</b>	<b>in.</b>	<b>in.</b>
MMF512BS55PP DM	0.4724 (0.00015)	2.1654 (0.0003)	0.9843 (0.0100)	0.88	3450	6060	4700	0.024	0.012	1.304	0.905
MMF515BS60PP DM	0.5906 (0.00015)	2.3622 (0.0003)	0.9843 (0.0100)	1.04	3600	6820	4290	0.024	0.012	1.456	1.088
MMF517BS62PP DM	0.6693 (0.00015)	2.4409 (0.0003)	0.9843 (0.0100)	1.08	3775	7550	4000	0.024	0.012	1.49	1.117
MMF520BS68PP DM	0.7874 (0.0002)	2.6772 (0.0003)	1.1024 (0.0100)	1.42	4900	10420	3400	0.024	0.012	1.700	1.357
MMF525BS75PP DM	0.9843 (0.0002)	2.9528 (0.0003)	1.1024 (0.0100)	1.68	5200	12360	2900	0.024	0.012	1.943	1.599
MMF530BS80PP DM	1.1811 (0.0002)	3.1496 (0.0003)	1.1024 (0.0100)	1.86	5500	14250	2600	0.024	0.012	2.138	1.795
MMF540BS100PP DM	1.5748 (0.00025)	3.937 (0.0003)	1.3386 (0.0100)	3.41	8150	22250	2070	0.024	0.012	2.704	2.264
MMF550BS115PP DM	1.9685 (0.00025)	4.5276 (0.0003)	1.3386 (0.0100)	4.37	9100	29660	1670	0.024	0.012	3.25	2.815
MMF550BS140PP DM	1.9685 (0.00025)	5.5118 (0.00035)	2.126 (0.0100)	10.78	21500	56000	1460	0.024	0.024	3.919	3.192
MMF560BS145PP DM	2.3622 (0.0003)	5.7087 (0.00035)	1.7717 (0.0100)	9.43	16000	47910	1400	0.024	0.024	3.938	3.308

<sup>(1)</sup>Grease fitting spacing (S) is conditional to the quantity of bolt holes: 3 holes, S = 60°; 4 holes, S = 45°; 6 holes, S = 30°; 8 holes, S = 22.5°; 12 holes, S = 15°.

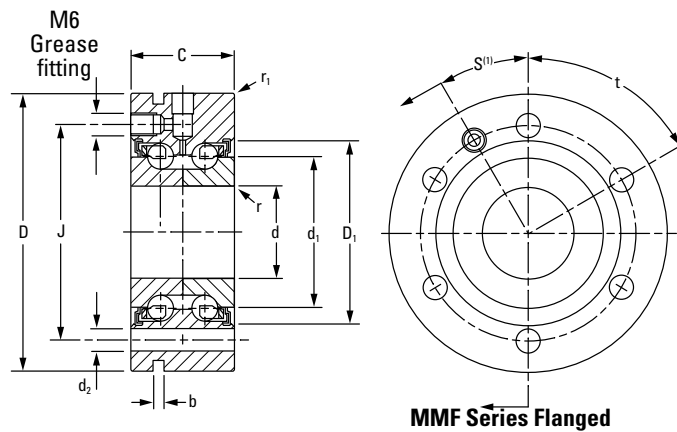

Bearing Number	Suggested Shoulder Dia.		d <sub>2</sub> Bolt Dia.	Holes	b Groove Width	J Bolt Circle Diameter	t Hole Spacing	Stiffness		Inertia Moment	Preload
	Housing	Shaft						Axial	Radial		
<b>METRIC</b>	mm	mm	mm	Qty.	mm	mm	Degrees	N/μm	N/μm	kg cm <sup>2</sup>	N
MMF512BS55PP DM	32.0	19.0	6.5	3	3	42	120	380	60	0.062	645
MMF515BS60PP DM	34.5	21.5	6.5	3	3	46	120	400	65	0.076	670
MMF517BS62PP DM	36.5	23.5	6.5	3	3	48	120	450	72	0.097	780
MMF520BS68PP DM	42.5	27.5	6.5	4	3	53	90	650	103	0.212	1780
MMF525BS75PP DM	48.0	33.5	6.5	4	3	58	90	750	118	0.415	2000
MMF530BS80PP DM	53.5	38.5	6.5	6	3	63	60	860	135	0.6	2335
MMF540BS100PP DM	67.0	49.0	8.5	4	3	80	90	1000	160	1.728	2780
MMF550BS115PP DM	81.0	63.0	8.5	6	3	94	60	1250	200	4.288	3335
MMF550BS140PP DM	98.5	66.0	10.5	12	3	113	30	1400	220	20.94	6784
MMF560BS145PP DM	98.0	72.0	8.5	8	3	120	45	1300	210	10.184	4225
<b>INCH</b>	in.	in.	in.	Qty.	in.	in.	Degrees	10 <sup>6</sup> lb/in.	10 <sup>6</sup> lb/in.	lb in. <sup>2</sup>	lbs.
MMF512BS55PP DM	1.26	0.748	0.256	3	0.118	1.654	120	2.17132	0.34284	0.021186466	145
MMF515BS60PP DM	1.358	0.846	0.256	3	0.118	1.811	120	2.2856	0.37141	0.025970506	150
MMF517BS62PP DM	1.437	0.925	0.256	3	0.118	1.89	120	2.5713	0.411408	0.033146567	175
MMF520BS68PP DM	1.673	1.083	0.256	4	0.118	2.087	90	3.7141	0.588542	0.072444044	400
MMF525BS75PP DM	1.890	1.319	0.256	4	0.118	2.283	90	4.2855	0.674252	0.141812634	450
MMF530BS80PP DM	2.106	1.516	0.256	6	0.118	2.48	60	4.91404	0.77139	0.205030314	525
MMF540BS100PP DM	2.638	1.929	0.335	4	0.118	3.15	90	5.714	0.91424	0.590487304	625
MMF550BS115PP DM	3.189	2.408	0.335	6	0.118	3.701	60	7.1425	1.1428	1.465283311	750
MMF550BS140PP DM	3.878	2.598	0.413	12	0.118	4.449	30	7.9996	1.25708	7.155557959	1525
MMF560BS145PP DM	3.858	2.835	0.335	8	0.118	4.724	45	7.4282	1.19994	3.480047863	950

**BALL SCREW SUPPORT BEARINGS  
SEALED, DOUBLE-ROW CARTRIDGE  
STYLE**

**MMN SERIES**

- Specifically designed for ball screw applications.
- Integral double-row design supports axial and combined loads.
- Nominal contact angle 60 degrees for superior axial rigidity and accuracy.
- Low torque, integral contact seals.
- Easy and flexible installation for both fixed and rotating nut designs.
- Sealed duplex configuration standard with optional seals, shields, ceramic balls and quadruplex sets available.

Bearing Number	d Bore	D O.D.	C Width	Wt.	Capacity		Speed Rating	Radius		d <sub>1</sub> Min.	D <sub>1</sub> Max.	Suggested Shoulder Dia.		Stiffness		Inertia Moment	Preload
					C Dynamic	C <sub>0a</sub> Static		r <sub>1</sub> Outer	r Inner			Housing	Shaft	Axial	Radial		
METRIC	mm +0/ - (µm)	mm +0/ - (µm)	mm +0/ - (µm)	kg	N	N	RPM	mm	mm	mm	mm	mm	mm	N/µm	N/µm	kg cm <sup>2</sup>	N
MMN512BS42PP DM	12 (3.8)	42 (6.4)	25 (254)	0.20	15300	26970	4700	0.6	0.3	25.0	33.1	32.0	19.0	380	60	0.062	645
MMN515BS45PP DM	15 (3.8)	45 (6.4)	25 (254)	0.23	16100	30350	4290	0.6	0.3	27.6	37.0	34.5	21.5	400	65	0.076	670
MMN517BS47PP DM	17 (3.8)	47 (6.4)	25 (254)	0.24	16800	33570	4000	0.6	0.3	28.4	37.8	36.5	23.5	450	72	0.097	780
MMN520BS52PP DM	20 (5.1)	52 (7.6)	28 (254)	0.32	21800	46360	3400	0.6	0.3	34.5	43.2	42.5	27.5	650	103	0.212	1780
MMN525BS57PP DM	25 (5.1)	57 (7.6)	28 (254)	0.35	23200	54980	2900	0.6	0.3	40.6	49.3	48.0	33.5	750	118	0.415	2000
MMN530BS62PP DM	30 (5.1)	62 (7.6)	28 (254)	0.40	24500	63370	2600	0.6	0.3	45.6	54.3	53.5	38.5	860	135	0.6	2335
MMN540BS75PPDM	40 (6.4)	75 (7.6)	34 (254)	0.64	36300	98980	2070	0.6	0.3	57.5	68.7	67.0	49.0	1000	160	1.728	2780
MMN550BS90PP DM	50 (6.4)	90 (7.6)	34 (254)	0.91	40500	131950	1670	0.6	0.3	71.5	82.6	81.0	63.0	1250	200	4.288	3335
MMN550BS110PP DM	50 (6.4)	110 (8.9)	54 (254)	2.42	95400	249080	1460	0.6	0.6	81.1	99.6	98.5	66.0	1400	220	20.94	6784
MMN560BS110PP DM	60 (7.6)	110 (8.9)	45 (254)	1.82	71200	213110	1400	0.6	0.6	84.0	100.0	98.0	72.0	1300	210	10.184	4225

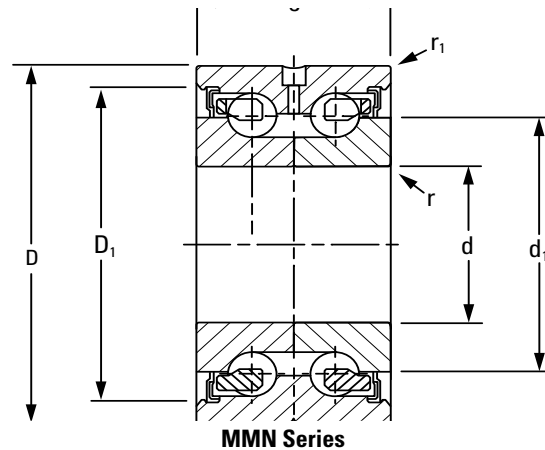

Bearing Number	d Bore	D O.D.	C Width	Wt.	Capacity		Speed Rating	Radius		d <sub>1</sub> Min.	D <sub>1</sub> Max.	Suggested Shoulder Dia.		Stiffness		Inertia Moment	Preload
					C Dynamic	C <sub>0a</sub> Static		r <sub>1</sub> Outer	r Inner			Housing	Shaft	Axial	Radial		
INCH	in. +0/-(x)			lbs.	lbs.		RPM	in.		in.	in.	in.	in.	10 <sup>6</sup> lb/in.	10 <sup>6</sup> lb/in.	lb in. <sup>2</sup>	lbs.
MMN512BS42PP DM	0.4724 (0.00015)	1.6535 (0.00025)	0.9843 (0.0100)	0.44	3450	6060	4700	0.024	0.012	1.304	0.985	1.259	0.748	2.17132	0.34284	0.021186466	145
MMN515BS45PP DM	0.5906 (0.00015)	1.7717 (0.00025)	0.9843 (0.0100)	0.5	3600	6820	4290	0.024	0.012	1.456	1.088	1.358	0.846	2.2856	0.37141	0.025970506	150
MMN517BS47PP DM	0.6693 (0.00015)	1.8504 (0.00025)	0.9843 (0.0100)	0.54	3775	7550	4000	0.024	0.012	1.49	1.117	1.437	0.925	2.5713	0.411408	0.033146567	175
MMN520BS52PP DM	0.7874 (0.0002)	2.0472 (0.0003)	1.1024 (0.0100)	0.70	4900	10420	3400	0.024	0.012	1.700	1.357	1.673	1.083	3.7141	0.588542	0.072444044	400
MMN525BS57PP DM	0.9843 (0.0002)	2.2441 (0.0003)	1.1024 (0.0100)	0.78	5200	12360	2900	0.024	0.012	1.943	1.599	1.890	1.319	4.2855	0.674252	0.141812634	450
MMN530BS62PP DM	1.1811 (0.0002)	2.4409 (0.0003)	1.1024 (0.0100)	0.88	5500	14250	2600	0.024	0.012	2.138	1.795	2.106	1.516	4.91404	0.77139	0.205030314	525
MMN540BS75PPDM	1.5748 (0.00025)	2.9528 (0.0003)	1.3386 (0.0100)	1.42	8150	22250	2070	0.024	0.012	2.704	2.264	2.638	1.929	5.714	0.91424	0.590487304	625
MMN550BS90PP DM	1.9685 (0.00025)	3.5433 (0.0003)	1.3386 (0.0100)	2.02	9100	29660	1670	0.024	0.012	3.250	2.815	3.189	2.408	7.1425	1.1428	1.465283311	750
MMN550BS110PP DM	1.9685 (0.00025)	4.3307 (0.00035)	2.126 (0.0100)	5.34	21500	56000	1460	0.024	0.024	3.919	3.192	3.878	2.598	7.9996	1.25708	7.155557959	1525
MMN560BS110PP DM	2.3622 (0.0003)	4.3307 (0.00035)	1.7717 (0.0100)	4.02	16000	47910	1400	0.024	0.024	3.938	3.308	3.858	2.835	7.4282	1.19994	3.480047863	950

**EX-CELL-O SPINDLE BEARINGS**

**MM-EX**

- “EX” Series (Timken WI construction) designed to meet Ex-Cell-O replacement requirements for inch nominal spindles with bore and O.D. tolerances nominal to plus.
- “XWO” Series (Timken WO separable construction) designed to meet Ex-Cell-O replacement requirements for inch nominal spindles with bore and O.D. tolerances nominal to minus.
- Measurement of shafts and housings (or reconditioning of parts) should determine replacement bearing style.
- Shafts and housings should be checked (and reworked) to avoid improper shaft and housing fits.
- Preload selection should be based on operating speed and lubrication system of spindle.

Bearing Number	Ex-Cell-O Part No.	Preload	Bore		O.D.		Width - Pair		Speed Rating Grease
			Max.	Min.	Max.	Min.	Max.	Min.	
		lbs.	in.	in.	in.	in.	in.	in.	RPM
MM20EXCR DU FS223	20	0	0.3752	0.3750	1.1252	1.1250	0.6875	0.6775	65000
MM30EXCR DU FS223	30	0	0.6252	0.6250	1.5002	1.5000	1.0000	0.9900	35000
MM30EXCR DU 5	30	5	0.6252	0.6250	1.5002	1.5000	1.0000	0.9900	25000
MM50EXCR DU FS223	50	0	0.8127	0.8125	2.0002	2.0000	1.0000	0.9900	30000
MM50EXCR DU 10 <sup>(1)</sup>	50	10	0.8127	0.8125	2.0002	2.0000	1.0000	0.9900	18000
MM50EXCR DU 50	50	50	0.8127	0.8125	2.0002	2.0000	1.0000	0.9900	5000
MM55EXCR DU 10	55	10	0.8127	0.8125	2.0002	2.0000	1.0000	0.9900	22000
MM57EXCR DU FS223	57	0	1.0627	1.0625	2.2502	2.2500	1.0000	0.9900	30000
MM57EXCR DU 10	57	10	1.0627	1.0625	2.2502	2.2500	1.0000	0.9900	15000
MM57EXCR DU 50	57	50	1.0627	1.0625	2.2502	2.2500	1.0000	0.9900	5000
MM67EXCR DU FS223	67	0	1.2502	1.2500	2.4377	2.4375	1.2500	1.2400	30000
MM67EXCR DU 10	67	10	1.2502	1.2500	2.4377	2.4375	1.2500	1.2400	12500
MM67EXCR DU 30	67	30	1.2502	1.2500	2.4377	2.4375	1.2500	1.2400	7500
MM67EXCR DU 75	67	75	1.2502	1.2500	2.4377	2.4375	1.2500	1.2400	4500
MM90EXCR DU 20	90	20	1.6252	1.6250	3.4377	3.4375	1.6250	1.6150	10000
MM90EXCR DU 100	90	100	1.6252	1.6250	3.4377	3.4375	1.6250	1.6150	4500
MM90EXCR DU 150	90	150	1.6252	1.6250	3.4377	3.4375	1.6250	1.6150	2700

<sup>(1)</sup>Four slots in outer ring faces.  
<sup>(2)</sup>No keyway in bore.  
 Do not interchange with MM-XWO.  
 MM-EX produced to nominal plus tolerance.



Bearing Number	Ex-Cell-O Part No.	Preload	Bore		O.D.		Width - Pair		Speed Rating Grease
			Max.	Min.	Max.	Min.	Max.	Min.	
		lbs.	in.	in.	in.	in.	in.	in.	RPM
MM90EXCR DU 250	90	250	1.6252	1.6250	3.4377	3.4375	1.6250	1.6150	900
MM92EXCR DU 20 <sup>(2)</sup>	92	20	1.7502	1.7500	3.4377	3.4375	1.6250	1.6150	12000
MM92EXCR DU 100 <sup>(2)</sup>	92	100	1.7502	1.7500	3.4377	3.4375	1.6250	1.6150	4500
MM92EXCR DU 150 <sup>(2)</sup>	92	150	1.7502	1.7500	3.4377	3.4375	1.6250	1.6150	2700
MM92EXCR DU 250 <sup>(2)</sup>	92	250	1.7502	1.7500	3.4377	3.4375	1.6250	1.6150	900
MM115EXCR DU 30	115	30	2.2502	2.2500	4.7502	4.7500	2.2500	2.2400	5000
MM115EXCR DU 250	115	250	2.2502	2.2500	4.7502	4.7500	2.2500	2.2400	3600
MM115EXCR DU 350	115	350	2.2502	2.2500	4.7502	4.7500	2.2500	2.2400	1800
MM135EXCR DU 20	135	20	1.2502	1.2500	2.6877	2.6875	1.2500	1.2400	8000
MM135EXCR DU 75	135	75	1.2502	1.2500	2.6877	2.6875	1.2500	1.2400	4000
MM155EXCR DU 150	155	150	2.7502	2.7500	4.7502	4.7500	2.2500	2.2400	4000
MM155EXCR DU 300	155	300	2.7502	2.7500	4.7502	4.7500	2.2500	2.2400	1800
MM165EXCR DU 200	165	200	3.5002	3.5000	6.3127	6.3125	3.0000	2.9900	2800
MM165EXCR DU 400	165	400	3.5002	3.5000	6.3127	6.3125	3.0000	2.9900	1200

***BALL BEARING BORE DIAMETERS FOUND IN THIS CATALOG***

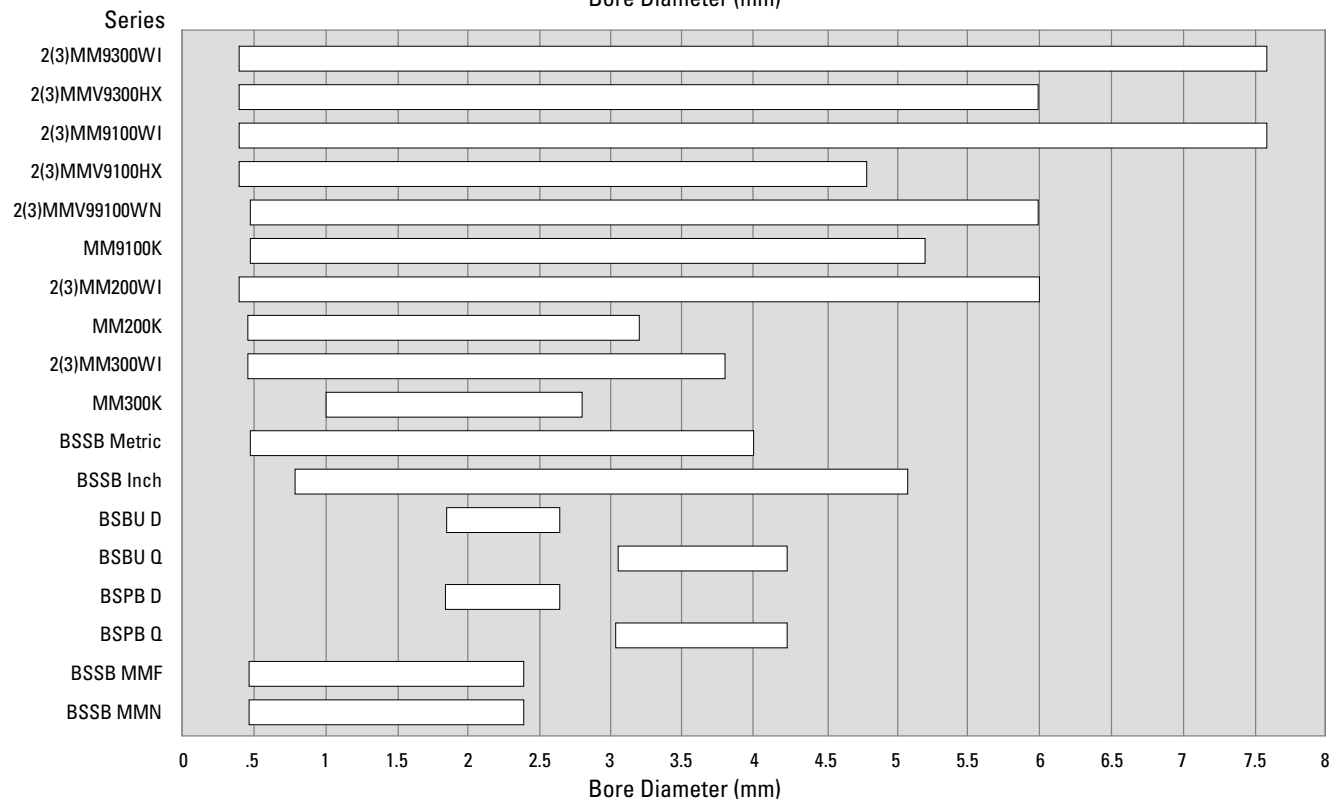
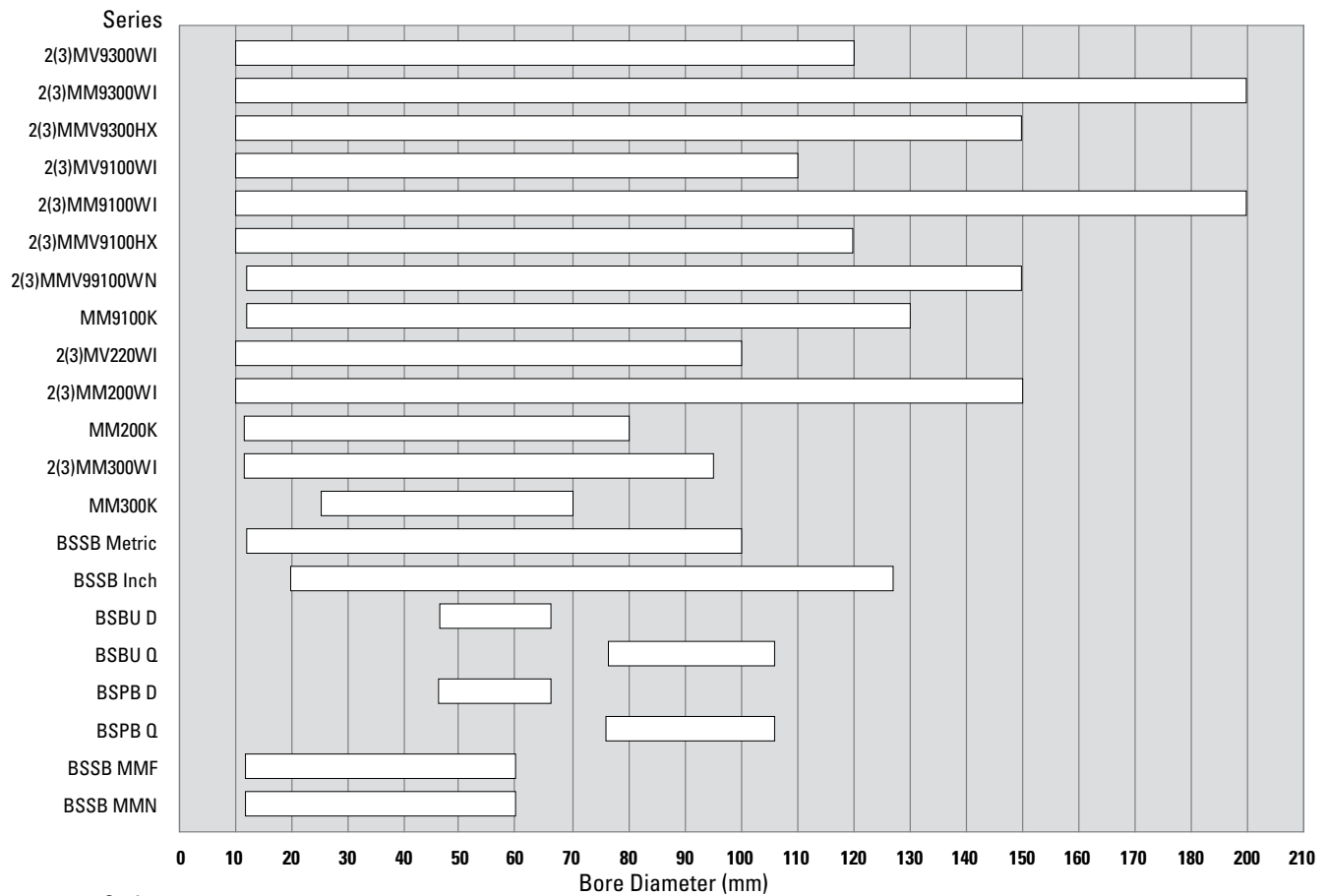

**Fig. 136. Bore diameters.**



## **APPENDIX**

Frequency Coefficients .....	216
Precision Tag Deviation and Runout Charts .....	233
Geometry Factors .....	235
Radial Internal Clearance .....	237
Bearing Locknuts and Torque .....	238
Lubrication Specifications .....	240
Operating Temperatures for Bearing Component Materials ..	242
Conversion Tables .....	244

## FREQUENCY COEFFICIENTS TAPERED ROLLER BEARINGS

Predictive maintenance of applications requires knowledge of the frequencies that a bearing can emit, which are based on its specific design. The tables that follow provide the most commonly used coefficients for this purpose. The frequencies are expressed as "Orders." To obtain bearing defect frequencies in Hz, multiply bearing coefficient by rotating speed in revolutions per second.

Tapered roller bearing example:

(FTF of JP6049-JP6010-B)

$$1200 \text{ RPM} \times 1 \text{ min}/60 \text{ sec} \times 0.436 = 8.72 \text{ Hz}$$

Ball bearing example:

(FTF of 2MM9300WI)

$$1200 \text{ RPM} \times 1 \text{ min}/60 \text{ sec} \times 0.4054 = 8.108 \text{ Hz}$$

### TS METRIC STYLE

**FTF:** Fundamental Train Frequency: the frequency at which the cage will operate.

**BSF:** Ball Spin Frequency: the frequency at which a single defect on a rolling element will be detected.

**BPF0:** Ball Pass Frequency Outer: the frequency at which a single defect in the outer race will be detected.

**BPFI:** Ball Pass Frequency Inner: the frequency at which a single defect in the inner race will be detected.

**TABLE 72.**  
**TS METRIC FREQUENCY COEFFICIENTS**

Part Number	FTF-Inner <sup>(1)</sup>	BSF	BPF0	BPFI	FTF-Outer <sup>(2)</sup>
JP6049-JP6010	0.436	3.676	8.275	10.725	0.564
JLM710949C-JLM710910	0.441	4.070	9.271	11.729	0.559
JP7049-JP7010	0.443	4.160	9.299	11.701	0.557
JP8049-JP8010	0.444	4.255	9.323	11.677	0.556
JM716649-JM716610	0.452	5.019	11.761	14.239	0.548
JP9049-JP9010	0.449	4.669	10.331	12.669	0.551
JP10044-JP10010	0.453	5.093	11.331	13.669	0.547
JM719149-JM719113	0.448	4.580	10.748	13.252	0.552
JP10049-JP10010	0.453	5.093	11.331	13.669	0.547
JM822049-JM822010	0.454	5.169	12.260	14.740	0.546
JLM722948-JLM722912	0.459	5.761	13.297	15.703	0.541
JL724348-JL724314	0.462	6.367	15.260	17.740	0.538
JL725346-JL725316	0.464	6.606	16.236	18.764	0.536
JP13049-JP13010	0.455	5.252	11.820	14.180	0.545
JP14049-JP14010	0.458	5.587	12.811	15.189	0.542
JL730646-JL730612	0.467	7.219	17.273	19.727	0.533
JP16049-JP16010	0.459	5.791	13.308	15.692	0.541
JP17049-JP17010	0.461	6.132	14.292	16.708	0.539
JP18049-JP18010	0.463	6.437	14.816	17.184	0.537
JM736149-JM736110	0.462	6.290	14.787	17.213	0.538

<sup>(1)</sup>For inner ring rotation.

<sup>(2)</sup>For outer ring rotation.

## TS INCH STYLE

**FTF:** Fundamental Train Frequency: the frequency at which the cage will operate.

**BSF:** Ball Spin Frequency: the frequency at which a single defect on a rolling element will be detected.

**BPFO:** Ball Pass Frequency Outer: the frequency at which a single defect in the outer race will be detected.

**BPFI:** Ball Pass Frequency Inner: the frequency at which a single defect in the inner race will be detected.

**TABLE 73.**  
**TS INCH FREQUENCY COEFFICIENTS**

Part Number	FTF-Inner <sup>(1)</sup>	BSF	BPFO	BPFI	FTF-Outer <sup>(2)</sup>
29585-29520	0.452	4.935	11.742	14.258	0.548
399A-394A	0.443	4.191	9.740	12.260	0.557
29685-29620	0.455	5.251	12.277	14.723	0.545
34301-34478	0.450	4.734	10.789	13.211	0.550
497-493	0.448	4.606	10.307	12.693	0.552
LM718947-LM718910	0.452	4.970	11.303	13.697	0.548
52400-52618	0.452	4.935	11.745	14.255	0.548
68462-68712	0.450	4.749	11.251	13.749	0.550
36690-36620	0.472	8.597	20.286	22.714	0.528
36990-36920	0.477	10.260	23.829	26.171	0.523
87750-87111	0.457	5.592	13.253	15.747	0.543
67985-67920	0.470	7.996	19.283	21.717	0.530
543085-543114	0.473	8.987	19.868	22.132	0.527

<sup>(1)</sup>For inner ring rotation.

<sup>(2)</sup>For outer ring rotation.

## TSF METRIC STYLE

**FTF:** Fundamental Train Frequency: the frequency at which the cage will operate.

**BSF:** Ball Spin Frequency: the frequency at which a single defect on a rolling element will be detected.

**BPFO:** Ball Pass Frequency Outer: the frequency at which a single defect in the outer race will be detected.

**BPFI:** Ball Pass Frequency Inner: the frequency at which a single defect in the inner race will be detected.

**TABLE 74.**  
**TSF METRIC FREQUENCY COEFFICIENTS**

Part Number	FTF-Inner <sup>(1)</sup>	BSF	BPFO	BPFI	FTF-Outer <sup>(2)</sup>
JP6049-JP6010-B	0.436	3.676	8.275	10.725	0.564
JP7049-JP7010-B	0.443	4.160	9.299	11.701	0.557
JP8049-JP8010-B	0.444	4.255	9.323	11.677	0.556
JP9049-JP9010-B	0.449	4.669	10.331	12.669	0.551
JP10044-JP10010-B	0.453	5.093	11.331	13.669	0.547
JP10049-JP10010-B	0.453	5.093	11.331	13.669	0.547
JP13049-JP13010-B	0.455	5.252	11.820	14.180	0.545
JP14049-JP14010-B	0.458	5.587	12.811	15.189	0.542
JL730646-JL730612-B	0.467	7.219	17.273	19.727	0.533

<sup>(1)</sup>For inner ring rotation.

<sup>(2)</sup>For outer ring rotation.

## TSF INCH STYLE

**TABLE 75.**  
**TSF INCH FREQUENCY COEFFICIENTS**

Part Number	FTF-Inner <sup>(1)</sup>	BSF	BPFO	BPFI	FTF-Outer <sup>(2)</sup>
2984-2924-B	0.434	3.643	8.244	10.755	0.566
3984-3920-B	0.443	4.191	9.740	12.260	0.557
482-472-B	0.439	3.948	8.783	11.217	0.561
566-563-B	0.435	3.713	8.705	11.295	0.565
33287-33462-B	0.448	4.568	10.295	12.705	0.552
27690-27620-B	0.457	5.599	12.340	14.660	0.543
42350-42587-B	0.454	5.118	11.793	14.207	0.546
683-672-B	0.446	4.367	10.247	12.753	0.555
687-672-B	0.446	4.367	10.247	12.753	0.555
71450-71750-B	0.444	4.296	10.217	12.783	0.556

<sup>(1)</sup>For inner ring rotation.

<sup>(2)</sup>For outer ring rotation.

## TSHR STYLE

**FTF:** Fundamental Train Frequency: the frequency at which the cage will operate.

**BSF:** Ball Spin Frequency: the frequency at which a single defect on a rolling element will be detected.

**BPFO:** Ball Pass Frequency Outer: the frequency at which a single defect in the outer race will be detected.

**BPFI:** Ball Pass Frequency Inner: the frequency at which a single defect in the inner race will be detected.

**TABLE 76.**  
**TSHR METRIC FREQUENCY COEFFICIENTS**

Part Number	FTF-Inner <sup>(1)</sup>	BSF	BPFO	BPFI	FTF-Outer <sup>(2)</sup>
JP5049P-JP5019HR	0.426	3.178	6.815	9.185	0.574
JP5049P-JP5020HR	0.426	3.178	6.815	9.185	0.574
JP5049PH-JP5017HR	0.426	3.178	6.815	9.185	0.574
JP5049PH-JP5020HR	0.426	3.178	6.815	9.185	0.574
JP7548P-JP7520HR	0.446	4.387	8.918	11.082	0.554
JP7549P-JP7519HR	0.446	4.387	8.918	11.082	0.554
JP8548-JP8518HR	0.447	4.462	9.827	12.173	0.553
JP8549P-JP8519HR	0.447	4.462	9.827	12.173	0.553
JP10048-JP10019HR	0.453	5.093	9.971	12.029	0.547
JP10048-JP10019HRA	0.453	5.093	9.971	12.029	0.547
JP11035-JP11019HR	0.452	4.955	9.937	12.063	0.548
JP11048-JP11019HR	0.452	4.955	9.937	12.063	0.548
JP12043P-JP12019HR	0.455	5.317	11.835	14.165	0.545
JP12049P-JP12019HR	0.455	5.317	11.835	14.165	0.545
JP13043P-JP13016HR	0.455	5.252	11.820	14.180	0.545
JP13049P-JP13016HR	0.455	5.252	11.820	14.180	0.545
JP14043P-JP14019HR	0.458	5.587	12.353	14.647	0.542
JP14049P-JP14019HR	0.458	5.587	12.353	14.647	0.542
JP16043P-JP16019HR	0.459	5.791	12.849	15.151	0.541
JP16049P-JP16019HR	0.459	5.791	12.849	15.151	0.541
JP17049P-JP17019HR	0.461	6.132	13.831	16.169	0.539
JP18049P-JP18019HR	0.463	6.437	14.353	16.647	0.537
JP20049P-JP20019HR	0.462	6.240	12.006	13.994	0.538
JP22049E-JP22019HR	0.465	6.769	13.949	16.051	0.535
JL555235-JL55512HR	0.472	8.567	16.041	17.959	0.528
JL555239-JL55512HR	0.472	8.567	16.041	17.959	0.528

<sup>(1)</sup>For inner ring rotation.

<sup>(2)</sup>For outer ring rotation.

## 2MV/MM9300WI SERIES (71900C-...-P4/P4S)

**FTF:** Fundamental Train Frequency: the frequency at which the cage will operate.

**BSF:** Ball Spin Frequency: the frequency at which a single defect on a rolling element will be detected.

**BPFO:** Ball Pass Frequency Outer: the frequency at which a single defect in the outer race will be detected.

**BPFI:** Ball Pass Frequency Inner: the frequency at which a single defect in the inner race will be detected.

**TABLE 77.**  
**2MM9300WI SERIES (71900C-...-P4S) FREQUENCY COEFFICIENTS**

Bearing Number	Timken ISO Bearing Number	FTF-Inner <sup>(1)</sup>	BSF	BPFO	BPFI	FTF-Outer <sup>(2)</sup>
2MV/MM9300WI	71900C-...-P4/P4S	0.4054	2.4294	4.8649	7.1351	0.5946
2MV/MM9301WI	71901C-...-P4/P4S	0.4159	2.7546	5.4070	7.5930	0.5841
2MV/MM9302WI	71902C-...-P4/P4S	0.4204	2.9335	5.4650	7.5350	0.5796
2MV/MM9303WI	71903C-...-P4/P4S	0.4272	3.2198	6.4074	8.5926	0.5728
2MV/MM9304WI	71904C-...-P4/P4S	0.4194	2.9144	5.8719	8.1281	0.5806
2MV/MM9305WI	71905C-...-P4/P4S	0.4314	3.4509	7.3346	9.6654	0.5686
2MV/MM9306WI	71906C-...-P4/P4S	0.4404	3.9846	8.3667	10.6333	0.5596
2MV/MM9307WI	71907C-...-P4/P4S	0.4405	3.9924	8.3695	10.6305	0.5595
2MV/MM9308WI	71908C-...-P4/P4S	0.4399	3.9578	8.3586	10.6414	0.5601
2MV/MM9309WI	71909C-...-P4/P4S	0.4458	4.3966	9.3612	11.6388	0.5542
2MV/MM9310WI	71910C-...-P4/P4S	0.4498	4.7547	10.3448	12.6552	0.5502
2MV/MM9311WI	71911C-...-P4/P4S	0.4490	4.6752	10.3262	12.6738	0.5510
2MV/MM9312WI	71912C-...-P4/P4S	0.4525	5.0286	11.3121	13.6879	0.5475
2MV/MM9313WI	71913C-...-P4/P4S	0.4556	5.3816	12.2999	14.7001	0.5444
2MV/MM9314WI	71914C-...-P4/P4S	0.4504	4.8196	10.8092	13.1908	0.5496
2MV/MM9315WI	71915C-...-P4/P4S	0.4531	5.1086	11.3285	13.6715	0.5469
2MV/MM9316WI	71916C-...-P4/P4S	0.4556	5.3974	12.3014	14.6986	0.5444
2MV/MM9317WI	71917C-...-P4/P4S	0.4557	5.3371	11.8322	14.1678	0.5449
2MV/MM9318WI	71918C-...-P4/P4S	0.4537	5.1643	11.7957	14.2043	0.5463
2MV/MM9319WI	71919C-...-P4/P4S	0.4557	5.4085	12.7607	15.2393	0.5443
2MV/MM9320WI	71920C-...-P4/P4S	0.4585	5.7746	13.2966	15.7034	0.5415
2MV/MM9322WI	71922C-...-P4/P4S	0.4617	6.2622	14.3126	16.6874	0.5383
2MV/MM9324WI	71924C-...-P4/P4S	0.4596	5.9438	13.7888	16.2112	0.5404
2MV/MM9326WI	71926C-...-P4/P4S	0.4580	5.7028	13.7392	16.2608	0.5420
2MV/MM9328WI	71928C-...-P4/P4S	0.4605	6.0759	14.7367	17.2633	0.5395
2MV/MM9330WI	71930C-...-P4/P4S	0.4531	5.1086	12.2348	14.7652	0.5469
2MV/MM9332WI	71932C-...-P4/P4S	0.4536	5.1589	12.2480	14.7520	0.5464
2MV/MM9334WI	71934C-...-P4/P4S	0.4559	5.4349	13.2209	15.7791	0.5441
2MV/MM9340WI	71940C-...-P4/P4S	0.4521	4.9931	12.2062	14.7938	0.5479

<sup>(1)</sup>For inner ring rotation.

<sup>(2)</sup>For outer ring rotation.



## 3MV/MM9300WI SERIES (71900E-...-P4/P4S)

**FTF:** Fundamental Train Frequency: the frequency at which the cage will operate.

**BSF:** Ball Spin Frequency: the frequency at which a single defect on a rolling element will be detected.

**BPFO:** Ball Pass Frequency Outer: the frequency at which a single defect in the outer race will be detected.

**BPFI:** Ball Pass Frequency Inner: the frequency at which a single defect in the inner race will be detected.

**TABLE 78.**  
**3MM9300WI SERIES (71900E-...-P4S) FREQUENCY COEFFICIENTS**

Bearing Number	Timken ISO Bearing Number	FTF-Inner <sup>(1)</sup>	BSF	BPFO	BPFI	FTF-Outer <sup>(2)</sup>
3MV/MM9300WI	71900E-...-P4/P4S	0.4100	2.4380	4.9204	7.0796	0.5900
3MV/MM9302WI	71902E-...-P4/P4S	0.4248	2.9417	5.5225	7.4775	0.5752
3MV/MM9303WI	71903E-...-P4/P4S	0.4312	3.2273	6.4681	8.5319	0.5688
3MV/MM9305WI	71905E-...-P4/P4S	0.4356	3.4586	7.4044	9.5956	0.5644
3MV/MM9306WI	71906E-...-P4/P4S	0.4439	3.9913	8.4346	10.5654	0.5561
3MV/MM9307WI	71907E-...-P4/P4S	0.4440	3.9990	8.4366	10.5634	0.5560
3MV/MM9308WI	71908E-...-P4/P4S	0.4437	3.9648	8.4295	10.5705	0.5563
3MV/MM9309WI	71909E-...-P4/P4S	0.4491	4.4029	9.4320	11.5680	0.5509
3MV/MM9310WI	71910E-...-P4/P4S	0.4529	4.7606	10.4166	12.5834	0.5471
3MV/MM9311WI	71911E-...-P4/P4S	0.4521	4.6811	10.3983	12.6017	0.5479
3MV/MM9312WI	71912E-...-P4/P4S	0.4554	5.0340	11.3851	13.6149	0.5446
3MV/MM9313WI	71913E-...-P4/P4S	0.4583	5.3867	12.3736	14.6264	0.5417
3MV/MM9314WI	71914E-...-P4/P4S	0.4535	4.8255	10.8839	13.1161	0.5465
3MV/MM9315WI	71915E-...-P4/P4S	0.4561	5.1141	11.4020	13.5980	0.5439
3MV/MM9316WI	71916E-...-P4/P4S	0.4584	5.4026	12.3766	14.6234	0.5416
3MV/MM9317WI	71917E-...-P4/P4S	0.4579	5.3423	11.9047	14.0953	0.5421
3MV/MM9318WI	71918E-...-P4/P4S	0.4565	5.1696	11.8699	14.1301	0.5435
3MV/MM9319WI	71919E-...-P4/P4S	0.4585	5.4136	12.8371	15.1629	0.5415
3MV/MM9320WI	71920E-...-P4/P4S	0.4611	5.7794	13.3708	15.6292	0.5389
3MV/MM9322WI	71922E-...-P4/P4S	0.4641	6.2666	14.3858	16.6142	0.5359
3MV/MM9324WI	71924E-...-P4/P4S	0.4622	5.9485	13.8645	16.1355	0.5378
3MV/MM9326WI	71926E-...-P4/P4S	0.4606	5.7077	13.8171	16.1829	0.5394
3MV/MM9328WI	71928E-...-P4/P4S	0.4630	6.0804	14.8147	17.1853	0.5370
3MV/MM9330WI	71930E-...-P4/P4S	0.4561	5.1141	12.3141	14.6859	0.5439
3MV/MM9334WI	71934E-...-P4/P4S	0.4586	5.4401	13.3007	15.6993	0.5414
3MV/MM9340WI	71940E-...-P4/P4S	0.4551	4.9987	12.2879	14.7121	0.5449

<sup>(1)</sup>For inner ring rotation.

<sup>(2)</sup>For outer ring rotation.

## 2MMV9300HX Series (HX71900C-...-P4S)

**FTF:** Fundamental Train Frequency: the frequency at which the cage will operate.

**BSF:** Ball Spin Frequency: the frequency at which a single defect on a rolling element will be detected.

**BPFO:** Ball Pass Frequency Outer: the frequency at which a single defect in the outer race will be detected.

**BPFI:** Ball Pass Frequency Inner: the frequency at which a single defect in the inner race will be detected.

**TABLE 79.**  
**2MMV9300HX SERIES (HX71900C-...-P4S) FREQUENCY COEFFICIENTS**

Bearing Number	Timken ISO Bearing Number	FTF-inner <sup>(1)</sup>	BSF	BPFO	BPFI	FTF-Outer <sup>(2)</sup>
2MMV9300HX	HX71900C-...-P4S	0.4283	3.2887	5.5682	7.4318	0.5717
2MMV9302HX	HX71902C-...-P4S	0.4363	3.7164	6.1081	7.8919	0.5637
2MMV9302HX	HX71902C-...-P4S	0.4378	3.8096	7.0041	8.9959	0.5622
2MMV9303HX	HX71903C-...-P4S	0.4431	4.1747	7.5319	9.4681	0.5569
2MMV9304HX	HX71904C-...-P4S	0.4396	3.9312	7.4726	9.5274	0.5604
2MMV9305HX	HX71905C-...-P4S	0.4486	4.6398	8.9717	11.0283	0.5514
2MMV9306HX	HX71906C-...-P4S	0.4553	5.3464	10.4710	12.5290	0.5447
2MMV9307HX	HX71907C-...-P4S	0.4575	5.6286	11.4364	13.5636	0.5425
2MMV9308HX	HX71908C-...-P4S	0.4400	3.9579	8.3598	10.6402	0.5600
2MMV9309HX	HX71909C-...-P4S	0.4458	4.3967	9.3624	11.6376	0.5542
2MMV9310HX	HX71910C-...-P4S	0.4498	4.7548	10.3460	12.6540	0.5502
2MMV9311HX	HX71911C-...-P4S	0.4490	4.6752	10.3262	12.6738	0.5510
2MMV9312HX	HX71912C-...-P4S	0.4525	5.0286	11.3121	13.6879	0.5475
2MMV9313HX	HX71913C-...-P4S	0.4556	5.3816	12.2999	14.7001	0.5444
2MMV9314HX	HX71914C-...-P4S	0.4504	4.8197	10.8104	13.1896	0.5496
2MMV9315HX	HX71915C-...-P4S	0.4532	5.1087	11.3297	13.6703	0.5468
2MMV9316HX	HX71916C-...-P4S	0.4557	5.3975	12.3026	14.6974	0.5443
2MMV9317HX	HX71917C-...-P4S	0.4551	5.3372	11.8338	14.1662	0.5449
2MMV9318HX	HX71918C-...-P4S	0.4537	5.1642	11.7952	14.2048	0.5463
2MMV9320HX	HX71920C-...-P4S	0.4585	5.7746	13.2961	15.7039	0.5415
2MMV9322HX	HX71922C-...-P4S	0.4617	6.2622	14.3121	16.6879	0.5383
2MMV9324HX	HX71924C-...-P4S	0.4596	5.9438	13.7892	16.2108	0.5404
2MMV9328HX	HX71928C-...-P4S	0.4605	6.0759	14.7371	17.2629	0.5395

<sup>(1)</sup>For inner ring rotation.

<sup>(2)</sup>For outer ring rotation.

## 3MMV9300HX SERIES (HX71900E-...-P4S)

**FTF:** Fundamental Train Frequency: the frequency at which the cage will operate.

**BSF:** Ball Spin Frequency: the frequency at which a single defect on a rolling element will be detected.

**BPFO:** Ball Pass Frequency Outer: the frequency at which a single defect in the outer race will be detected.

**BPFI:** Ball Pass Frequency Inner: the frequency at which a single defect in the inner race will be detected.

**TABLE 80.**  
**3MMV9300HX SERIES (HX71900E-...-P4S) FREQUENCY COEFFICIENTS**

Bearing Number	Timken ISO Bearing Number	FTF-Inner <sup>(1)</sup>	BSF	BPFO	BPFI	FTF-Outer <sup>(2)</sup>
3MMV9300HX	HX71900E-...-P4S	0.4327	3.2987	5.6255	7.3745	0.5673
3MMV9301HX	HX71901E-...-P4S	0.4402	3.7257	6.1629	7.8371	0.5598
3MMV9302HX	HX71902E-...-P4S	0.4416	3.8167	7.0655	8.9345	0.5584
3MMV9303HX	HX71903E-...-P4S	0.4466	4.1812	7.5916	9.4084	0.5534
3MMV9304HX	HX71904E-...-P4S	0.4434	3.9383	7.5370	9.4630	0.5566
3MMV9305HX	HX71905E-...-P4S	0.4518	4.6459	9.0361	10.9639	0.5482
3MMV9306HX	HX71906E-...-P4S	0.4581	5.3516	10.5355	12.4645	0.5419
3MMV9307HX	HX71907E-...-P4S	0.4601	5.6336	11.5035	13.4965	0.5399
3MMV9308HX	HX71908E-...-P4S	0.4436	3.9647	8.4284	10.5716	0.5564
3MMV9309HX	HX71909E-...-P4S	0.4491	4.4028	9.4309	11.5691	0.5509
3MMV9310HX	HX71910E-...-P4S	0.4528	4.7605	10.4154	12.5846	0.5472
3MMV9311HX	HX71911E-...-P4S	0.4521	4.6810	10.3976	12.6024	0.5479
3MMV9312HX	HX71912E-...-P4S	0.4554	5.0340	11.3844	13.6156	0.5446
3MMV9313HX	HX71913E-...-P4S	0.4583	5.3866	12.3729	14.6271	0.5417
3MMV9314HX	HX71914E-...-P4S	0.4535	4.8255	10.8839	13.1161	0.5465
3MMV9315HX	HX71915E-...-P4S	0.4561	5.1141	11.4020	13.5980	0.5439
3MMV9316HX	HX71916E-...-P4S	0.4584	5.4026	12.3766	14.6234	0.5416
3MMV9317HX	HX71917E-...-P4S	0.4579	5.3425	11.9063	14.0937	0.5421
3MMV9318HX	HX71918E-...-P4S	0.4566	5.1697	11.8704	14.1296	0.5434
3MMV9320HX	HX71920E-...-P4S	0.4611	5.7794	13.3713	15.6287	0.5389
3MMV9322HX	HX71922E-...-P4S	0.4641	6.2667	14.3863	16.6137	0.5359
3MMV9324HX	HX71924E-...-P4S	0.4622	5.9486	13.8654	16.1346	0.5378
3MMV9328HX	HX71928E-...-P4S	0.4630	6.0805	14.8159	17.1841	0.5370

<sup>(1)</sup>For inner ring rotation.

<sup>(2)</sup>For outer ring rotation.

2MV/MM9100WI SERIES (7000C-...-P4/P4S)

**FTF:** Fundamental Train Frequency: the frequency at which the cage will operate.

**BPFO:** Ball Pass Frequency Outer: the frequency at which a single defect in the outer race will be detected.

**BSF:** Ball Spin Frequency: the frequency at which a single defect on a rolling element will be detected.

**BPFI:** Ball Pass Frequency Inner: the frequency at which a single defect in the inner race will be detected.

**TABLE 81.**  
**2MM9100WI SERIES (7000C-...-P4S) FREQUENCY COEFFICIENTS**

Bearing Number	Timken ISO Bearing Number	FTF-Inner <sup>(1)</sup>	BSF	BPFO	BPFI	FTF-Outer <sup>(2)</sup>
2MV/MM9100WI	7000C-...-P4/P4S	0.3740	1.7697	2.9924	5.0076	0.6260
2MV/MM9101WI	7001C-...-P4/P4S	0.3902	2.0621	3.9015	6.0985	0.6098
2MV/MM9102WI	7002C-...-P4/P4S	0.4035	2.3754	4.8424	7.1576	0.5965
2MV/MM9103WI	7003C-...-P4/P4S	0.4126	2.6411	4.5390	6.4610	0.5874
2MV/MM9104WI	7004C-...-P4/P4S	0.4013	2.3458	4.4140	6.5860	0.5987
2MV/MM9105WI	7005C-...-P4/P4S	0.4150	2.7526	5.3947	7.6053	0.5850
2MV/MM9106WI	7006C-...-P4/P4S	0.4201	2.9387	5.8807	8.1193	0.5799
2MV/MM9107WI	7007C-...-P4/P4S	0.4210	2.9789	6.3157	8.6843	0.5790
2MV/MM9108WI	7008C-...-P4/P4S	0.4291	3.3332	6.8655	9.1345	0.5709
2MV/MM9109WI	7009C-...-P4/P4S	0.4298	3.3682	7.3063	9.6937	0.5702
2MV/MM9110WI	7010C-...-P4/P4S	0.4352	3.6596	7.8332	10.1668	0.5648
2MV/MM9111WI	7011C-...-P4/P4S	0.4314	3.4469	7.7648	10.2352	0.5686
2MV/MM9112WI	7012C-...-P4/P4S	0.4358	3.6934	8.2803	10.7197	0.5642
2MV/MM9113WI	7013C-...-P4/P4S	0.4397	3.9394	8.7939	11.2061	0.5603
2MV/MM9114WI	7014C-...-P4/P4S	0.4362	3.7179	8.2875	10.7125	0.5638
2MV/MM9115WI	7015C-...-P4/P4S	0.4395	3.9312	8.7908	11.2092	0.5605
2MV/MM9116WI	7016C-...-P4/P4S	0.4365	3.7369	8.7306	11.2694	0.5635
2MV/MM9117WI	7017C-...-P4/P4S	0.4396	3.9332	9.2317	11.7683	0.5604
2MV/MM9118WI	7018C-...-P4/P4S	0.4367	3.7517	8.7350	11.2650	0.5633
2MV/MM9119WI	7019C-...-P4/P4S	0.4394	3.9200	9.2271	11.7729	0.5606
2MV/MM9120WI	7020C-...-P4/P4S	0.4418	4.0881	9.7198	12.2802	0.5582
2MV/MM9121WI	7021C-...-P4/P4S	0.4393	3.9167	9.2256	11.7744	0.5607
2MV/MM9122WI	7022C-...-P4/P4S	0.4399	3.9507	9.6778	12.3222	0.5601
2MV/MM9124WI	7024C-...-P4/P4S	0.4439	4.2417	10.2102	12.7898	0.5561
2MV/MM9126WI	7026C-...-P4/P4S	0.4397	3.9394	9.2336	11.7664	0.5603
2MV/MM9128WI	7028C-...-P4/P4S	0.4431	4.1850	9.7491	12.2509	0.5569
2MV/MM9130WI	7030C-...-P4/P4S	0.4428	4.1640	9.7426	12.2574	0.5572
2MV/MM9132WI	7032C-...-P4/P4S	0.4426	4.1450	9.7367	12.2633	0.5574
2MV/MM9134WI	7034C-...-P4/P4S	0.4394	3.9247	9.6660	12.3340	0.5606
2MV/MM9136WI	7036C-...-P4/P4S	0.4367	3.7516	8.7339	11.2661	0.5633
2MV/MM9140WI	7040C-...-P4/P4S	0.4369	3.7645	8.7378	11.2622	0.5631

<sup>(1)</sup>For inner ring rotation.

<sup>(2)</sup>For outer ring rotation.

## 3MV/MM9100WI SERIES (7000E-...-P4/P4S)

**FTF:** Fundamental Train Frequency: the frequency at which the cage will operate.

**BPFO:** Ball Pass Frequency Outer: the frequency at which a single defect in the outer race will be detected.

**BSF:** Ball Spin Frequency: the frequency at which a single defect on a rolling element will be detected.

**BPFI:** Ball Pass Frequency Inner: the frequency at which a single defect in the inner race will be detected.

**TABLE 82.**  
**3MM9100WI SERIES (7000E-...-P4S) FREQUENCY COEFFICIENTS**

Bearing Number	Timken ISO Bearing Number	FTF-Inner <sup>(1)</sup>	BSF	BPFO	BPFI	FTF-Outer <sup>(2)</sup>
3MV/MM9100WI	7000E-...-P4/P4S	0.3740	1.7697	2.9924	5.0076	0.6260
3MV/MM9101WI	7001E-...-P4/P4S	0.3957	2.0724	3.9569	6.0431	0.6043
3MV/MM9102WI	7002E-...-P4/P4S	0.4084	2.3844	4.4924	6.5076	0.5916
3MV/MM9103WI	7003E-...-P4/P4S	0.4170	2.6493	4.5875	6.4125	0.5830
3MV/MM9104WI	7004E-...-P4/P4S	0.4074	2.3573	4.4816	6.5184	0.5926
3MV/MM9105WI	7005E-...-P4/P4S	0.4203	2.7625	5.4635	7.5365	0.5797
3MV/MM9106WI	7006E-...-P4/P4S	0.4243	2.9475	5.9467	8.0533	0.5752
3MV/MM9107WI	7007E-...-P4/P4S	0.4258	2.9877	6.3864	8.6136	0.5742
3MV/MM9108WI	7008E-...-P4/P4S	0.4333	3.3411	6.9332	9.0668	0.5667
3MV/MM9109WI	7009E-...-P4/P4S	0.4340	3.3761	7.3782	9.6218	0.5660
3MV/MM9110WI	7010E-...-P4/P4S	0.4391	3.6669	7.9036	10.0964	0.5609
3MV/MM9111WI	7011E-...-P4/P4S	0.4354	3.4544	7.8373	10.1627	0.5646
3MV/MM9112WI	7012E-...-P4/P4S	0.4396	3.7005	8.3519	10.6481	0.5604
3MV/MM9113WI	7013E-...-P4/P4S	0.4432	3.9461	8.8647	11.1353	0.5568
3MV/MM9114WI	7014E-...-P4/P4S	0.4400	3.7251	8.3599	10.6401	0.5600
3MV/MM9115WI	7015E-...-P4/P4S	0.4432	3.9379	8.8630	11.1370	0.5568
3MV/MM9116WI	7016E-...-P4/P4S	0.4404	3.7441	8.8074	11.1926	0.5596
3MV/MM9117WI	7017E-...-P4/P4S	0.4433	3.9400	9.3085	11.6915	0.5567
3MV/MM9118WI	7018E-...-P4/P4S	0.4405	3.7587	8.8101	11.1899	0.5595
3MV/MM9119WI	7019E-...-P4/P4S	0.4430	3.9267	9.3026	11.6974	0.5570
3MV/MM9120WI	7020E-...-P4/P4S	0.4453	4.0945	9.7958	12.2042	0.5547
3MV/MM9121WI	7021E-...-P4/P4S	0.4430	3.9235	9.3021	11.6979	0.5570
3MV/MM9122WI	7022E-...-P4/P4S	0.4434	3.9573	9.7557	12.2443	0.5566
3MV/MM9124WI	7024E-...-P4/P4S	0.4472	4.2479	10.2861	12.7139	0.5528
3MV/MM9126WI	7026E-...-P4/P4S	0.4433	3.9462	9.3096	11.6904	0.5567
3MV/MM9128WI	7028E-...-P4/P4S	0.4466	4.1914	9.8241	12.1759	0.5534
3MV/MM9130WI	7030E-...-P4/P4S	0.4463	4.1705	9.8186	12.1814	0.5537
3MV/MM9132WI	7032E-...-P4/P4S	0.4461	4.1515	9.8135	12.1865	0.5539
3MV/MM9134WI	7034E-...-P4/P4S	0.4431	3.9318	9.7492	12.2508	0.5569
3MV/MM9136WI	7036E-...-P4/P4S	0.4406	3.7588	8.8114	11.1886	0.5594
3MV/MM9140WI	7040E-...-P4/P4S	0.4408	3.7719	8.8164	11.1836	0.5592

<sup>(1)</sup>For inner ring rotation.

<sup>(2)</sup>For outer ring rotation.

## 2MMV9100HX SERIES (HX7000C-...-P4S)

**FTF:** Fundamental Train Frequency: the frequency at which the cage will operate.

**BSF:** Ball Spin Frequency: the frequency at which a single defect on a rolling element will be detected.

**BPFO:** Ball Pass Frequency Outer: the frequency at which a single defect in the outer race will be detected.

**BPMF:** Ball Pass Frequency Inner: the frequency at which a single defect in the inner race will be detected.

**TABLE 83.**  
**2MMV9100HX SERIES (HX7000C-...-P4S) FREQUENCY COEFFICIENTS**

Bearing Number	Timken ISO Bearing Number	FTF-Inner <sup>(1)</sup>	BSF	BPFO	BPMF	FTF-Outer <sup>(2)</sup>
2MMV9100HX	HX7000C-...-P4S	0.3834	1.9496	3.8344	6.1656	0.6166
2MMV9101HX	HX7001C-...-P4S	0.4043	2.4274	4.4474	6.5526	0.5957
2MMV9102HX	HX7002C-...-P4S	0.4023	2.3729	4.8273	7.1727	0.5977
2MMV9103HX	HX7003C-...-P4S	0.4117	2.6444	4.5283	6.4717	0.5883
2MMV9104HX	HX7004C-...-P4S	0.4012	2.3457	4.8147	7.1853	0.5988
2MMV9105HX	HX7005C-...-P4S	0.4043	2.4274	5.2560	7.7440	0.5957
2MMV9106HX	HX7006C-...-P4S	0.4099	2.5903	5.3292	7.6708	0.5901
2MMV9107HX	HX7007C-...-P4S	0.4211	2.9789	6.3162	8.6838	0.5789
2MMV9108HX	HX7008C-...-P4S	0.4291	3.3332	6.8659	9.1341	0.5709
2MMV9109HX	HX7009C-...-P4S	0.4298	3.3682	7.3070	9.6930	0.5702
2MMV9110HX	HX7010C-...-P4S	0.4352	3.6597	7.8340	10.1660	0.5648
2MMV9111HX	HX7011C-...-P4S	0.4472	4.5160	10.7329	13.2671	0.5528
2MMV9112HX	HX7012C-...-P4S	0.4506	4.8343	11.2653	13.7347	0.5494
2MMV9113HX	HX7013C-...-P4S	0.4490	4.6751	11.2241	13.7759	0.5510
2MMV9114HX	HX7014C-...-P4S	0.4490	4.6752	11.2241	13.7759	0.5510
2MMV9115HX	HX7015C-...-P4S	0.4517	4.9403	11.7429	14.2571	0.5483
2MMV9116HX	HX7016C-...-P4S	0.4477	4.5613	11.1913	13.8087	0.5523
2MMV9117HX	HX7017C-...-P4S	0.4502	4.7888	11.7039	14.2961	0.5498
2MMV9118HX	HX7018C-...-P4S	0.4534	5.1295	12.6953	15.3047	0.5466
2MMV9120HX	HX7020C-...-P4S	0.4510	4.8740	12.1772	14.8228	0.5490
2MMV9122HX	HX7022C-...-P4S	0.4563	5.4696	13.6877	16.3123	0.5437
2MMV9124HX	HX7024C-...-P4S	0.4542	5.2052	13.1707	15.8293	0.5458

<sup>(1)</sup>For inner ring rotation.

<sup>(2)</sup>For outer ring rotation.

## 3MMV9100HX SERIES (HX7000E-...-P4S)

**FTF:** Fundamental Train Frequency: the frequency at which the cage will operate.

**BSF:** Ball Spin Frequency: the frequency at which a single defect on a rolling element will be detected.

**BPFO:** Ball Pass Frequency Outer: the frequency at which a single defect in the outer race will be detected.

**BPFI:** Ball Pass Frequency Inner: the frequency at which a single defect in the inner race will be detected.

**TABLE 84.**  
**3MMV9100HX SERIES (HX7000E-...-P4S) FREQUENCY COEFFICIENTS**

Bearing Number	Timken ISO Bearing Number	FTF-Inner <sup>(1)</sup>	BSF	BPFO	BPFI	FTF-Outer <sup>(2)</sup>
3MMV9100HX	HX7000E-...-P4S	0.4003	2.1778	4.0035	5.9965	0.5997
3MMV9101HX	HX7001E-...-P4S	0.4103	2.4386	4.5134	6.4866	0.5897
3MMV9102HX	HX7002E-...-P4S	0.4083	2.3842	4.8993	7.1007	0.5917
3MMV9103HX	HX7003E-...-P4S	0.4171	2.6546	4.5880	6.4120	0.5829
3MMV9104HX	HX7004E-...-P4S	0.4071	2.3568	4.8857	7.1143	0.5929
3MMV9105HX	HX7005E-...-P4S	0.4202	2.7625	5.4630	7.5370	0.5798
3MMV9106HX	HX7006E-...-P4S	0.4250	2.9479	5.9495	8.0505	0.5750
3MMV9107HX	HX7007E-...-P4S	0.4259	2.9879	6.3882	8.6118	0.5741
3MMV9108HX	HX7008E-...-P4S	0.4334	3.3413	6.9349	9.0651	0.5666
3MMV9109HX	HX7009E-...-P4S	0.4341	3.3762	7.3791	9.6209	0.5659
3MMV9110HX	HX7010E-...-P4S	0.4391	3.6670	7.9044	10.0956	0.5609
3MMV9111HX	HX7011E-...-P4S	0.4504	4.5220	10.8100	13.1900	0.5496
3MMV9112HX	HX7012E-...-P4S	0.4536	4.8399	11.3404	13.6596	0.5464
3MMV9113HX	HX7013E-...-P4S	0.4520	4.6809	11.3011	13.6989	0.5480
3MMV9114HX	HX7014E-...-P4S	0.4521	4.6810	11.3025	13.6975	0.5479
3MMV9115HX	HX7015E-...-P4S	0.4545	4.9457	11.8182	14.1818	0.5455
3MMV9116HX	HX7016E-...-P4S	0.4509	4.5674	11.2722	13.7278	0.5491
3MMV9117HX	HX7017E-...-P4S	0.4532	4.7945	11.7824	14.2176	0.5468
3MMV9118HX	HX7018E-...-P4S	0.4562	5.1347	12.7743	15.2257	0.5438
3MMV9120HX	HX7020E-...-P4S	0.4540	4.8796	12.2580	14.7420	0.5460
3MMV9122HX	HX7022E-...-P4S	0.4589	5.4746	13.7678	16.2322	0.5411
3MMV9124HX	HX7024E-...-P4S	0.4568	5.2102	13.2485	15.7515	0.5432

<sup>(1)</sup>For inner ring rotation.

<sup>(2)</sup>For outer ring rotation.

2MV/MM200WI SERIES (7200C-...-P4/P4S)

**FTF:** Fundamental Train Frequency: the frequency at which the cage will operate.

**BPFO:** Ball Pass Frequency Outer: the frequency at which a single defect in the outer race will be detected.

**BSF:** Ball Spin Frequency: the frequency at which a single defect on a rolling element will be detected.

**BPFI:** Ball Pass Frequency Inner: the frequency at which a single defect in the inner race will be detected.

**TABLE 85.**  
**2MM200WI SERIES (7200C-...-P4S) FREQUENCY COEFFICIENTS**

Bearing Number	Timken ISO Bearing Number	FTF-Inner <sup>(1)</sup>	BSF	BPFO	BPFI	FTF-Outer <sup>(2)</sup>
2MV/MM200WI	7200C-...-P4/P4S	0.3668	1.6722	2.9345	5.0655	0.6332
2MV/MM201WI	7201C-...-P4/P4S	0.3699	1.7226	3.3290	5.6710	0.6301
2MV/MM202WI	7202C-...-P4/P4S	0.3855	1.9898	3.8552	6.1448	0.6145
2MV/MM203WI	7203C-...-P4/P4S	0.3861	2.0025	3.8609	6.1391	0.6139
2MV/MM204WI	7204C-...-P4/P4S	0.3857	2.0000	3.8570	6.1430	0.6143
2MV/MM205WI	7205C-...-P4/P4S	0.4008	2.3347	4.8091	7.1909	0.5992
2MV/MM206WI	7206C-...-P4/P4S	0.4001	2.3182	4.8007	7.1993	0.5999
2MV/MM207WI	7207C-...-P4/P4S	0.3997	2.3104	4.7965	7.2035	0.6003
2MV/MM208WI	7208C-...-P4/P4S	0.3980	2.2638	4.3777	6.6223	0.6020
2MV/MM209WI	7209C-...-P4/P4S	0.4058	2.4683	5.2757	7.7243	0.5942
2MV/MM210WI	7210C-...-P4/P4S	0.4126	2.6716	5.7757	8.2243	0.5874
2MV/MM211WI	7211C-...-P4/P4S	0.4110	2.6263	5.7543	8.2457	0.5890
2MV/MM212WI	7212C-...-P4/P4S	0.4098	2.5901	5.7376	8.2624	0.5902
2MV/MM213WI	7213C-...-P4/P4S	0.4130	2.6906	5.7818	8.2182	0.5870
2MV/MM214WI	7214C-...-P4/P4S	0.4135	2.7082	5.7891	8.2109	0.5865
2MV/MM215WI	7215C-...-P4/P4S	0.4177	2.8554	6.2659	8.7341	0.5823
2MV/MM216WI	7216C-...-P4/P4S	0.4164	2.8064	6.2462	8.7538	0.5836
2MV/MM217WI	7217C-...-P4/P4S	0.4152	2.7649	6.2281	8.7719	0.5848
2MV/MM218WI	7218C-...-P4/P4S	0.4142	2.7301	5.7984	8.2016	0.5858
2MV/MM219WI	7219C-...-P4/P4S	0.4132	2.6992	5.7853	8.2147	0.5868
2MV/MM220WI	7220C-...-P4/P4S	0.4125	2.6714	5.7744	8.2256	0.5875
2MV/MM222WI	7222C-...-P4/P4S	0.4110	2.6263	5.7543	8.2457	0.5890
2MV/MM224WI	7224C-...-P4/P4S	0.4131	2.6927	5.7830	8.2170	0.5869
2MV/MM226WI	7226C-...-P4/P4S	0.4192	2.9059	7.1260	9.8740	0.5808
2MV/MM230WI	7230C-...-P4/P4S	0.4124	2.6714	6.1865	8.8135	0.5876

<sup>(1)</sup>For inner ring rotation.

<sup>(2)</sup>For outer ring rotation.



## 3MV/MM200WI SERIES (7200E-...-P4/P4S)

**FTF:** Fundamental Train Frequency: the frequency at which the cage will operate.

**BPFO:** Ball Pass Frequency Outer: the frequency at which a single defect in the outer race will be detected.

**BSF:** Ball Spin Frequency: the frequency at which a single defect on a rolling element will be detected.

**BPFI:** Ball Pass Frequency Inner: the frequency at which a single defect in the inner race will be detected.

**TABLE 86.**  
**3MM200WI SERIES (7200E-...-P4S) FREQUENCY COEFFICIENTS**

Bearing Number	Timken ISO Bearing Number	FTF-Inner <sup>(1)</sup>	BSF	BPFO	BPFI	FTF-Outer <sup>(2)</sup>
3MV/MM200WI	7200E-...-P4/P4S	0.3668	1.6722	2.9345	5.0655	0.6332
3MV/MM201WI	7201E-...-P4/P4S	0.3774	1.7366	3.3966	5.6034	0.6226
3MV/MM202WI	7202E-...-P4/P4S	0.3921	2.0021	3.9212	6.0788	0.6079
3MV/MM203WI	7203E-...-P4/P4S	0.3928	2.0150	3.9277	6.0723	0.6072
3MV/MM204WI	7204E-...-P4/P4S	0.3929	2.0134	3.9290	6.0710	0.6071
3MV/MM205WI	7205E-...-P4/P4S	0.4070	2.3463	4.8841	7.1159	0.5930
3MV/MM206WI	7206E-...-P4/P4S	0.4064	2.3301	4.8769	7.1231	0.5936
3MV/MM207WI	7207E-...-P4/P4S	0.4061	2.3224	4.8734	7.1266	0.5939
3MV/MM208WI	7208E-...-P4/P4S	0.4043	2.2757	4.4476	6.5524	0.5957
3MV/MM209WI	7209E-...-P4/P4S	0.4117	2.4793	5.3519	7.6481	0.5883
3MV/MM210WI	7210E-...-P4/P4S	0.4180	2.6818	5.8519	8.1481	0.5820
3MV/MM211WI	7211E-...-P4/P4S	0.4166	2.6367	5.8323	8.1677	0.5834
3MV/MM212WI	7212E-...-P4/P4S	0.4155	2.6007	5.8171	8.1829	0.5845
3MV/MM213WI	7213E-...-P4/P4S	0.4185	2.7009	5.8587	8.1413	0.5815
3MV/MM214WI	7214E-...-P4/P4S	0.4189	2.7182	5.8639	8.1361	0.5811
3MV/MM215WI	7215E-...-P4/P4S	0.4228	2.8649	6.3421	8.6579	0.5772
3MV/MM216WI	7216E-...-P4/P4S	0.4216	2.8162	6.3241	8.6759	0.5784
3MV/MM217WI	7217E-...-P4/P4S	0.4205	2.7748	6.3076	8.6924	0.5795
3MV/MM218WI	7218E-...-P4/P4S	0.4196	2.7402	5.8738	8.1262	0.5804
3MV/MM219WI	7219E-...-P4/P4S	0.4187	2.7094	5.8618	8.1382	0.5813
3MV/MM220WI	7220E-...-P4/P4S	0.4179	2.6816	5.8506	8.1494	0.5821
3MV/MM222WI	7222E-...-P4/P4S	0.4166	2.6367	5.8323	8.1677	0.5834
3MV/MM224WI	7224E-...-P4/P4S	0.4184	2.7026	5.8573	8.1427	0.5816
3MV/MM226WI	7226E-...-P4/P4S	0.4241	2.9151	7.2100	9.7900	0.5759
3MV/MM230WI	7230E-...-P4/P4S	0.4179	2.6815	6.2681	8.7319	0.5821

<sup>(1)</sup>For inner ring rotation.

<sup>(2)</sup>For outer ring rotation.

## 2MM300WI SERIES (7300C-...-P4S)

**FTF:** Fundamental Train Frequency: the frequency at which the cage will operate.

**BPFO:** Ball Pass Frequency Outer: the frequency at which a single defect in the outer race will be detected.

**BSF:** Ball Spin Frequency: the frequency at which a single defect on a rolling element will be detected.

**BPFI:** Ball Pass Frequency Inner: the frequency at which a single defect in the inner race will be detected.

**TABLE 87.**  
**2MM300WI SERIES (7300C-...-P4S) FREQUENCY COEFFICIENTS**

Bearing Number	Timken ISO Bearing Number	FTF-Inner <sup>(1)</sup>	BSF	BPFO	BPFI	FTF-Outer <sup>(2)</sup>
2MM301WI	7301C-...-P4S	0.3594	1.5791	2.8751	5.1249	0.6406
2MM302WI	7302C-...-P4S	0.3861	2.0024	3.8609	6.1391	0.6139
2MM303WI	7303C-...-P4S	0.3564	1.5411	2.4946	4.5054	0.6436
2MM304WI	7304C-...-P4S	0.3618	1.6111	2.8941	5.1059	0.6382
2MM305WI	7305C-...-P4S	0.3681	1.6997	3.3127	5.6873	0.6319
2MM306WI	7306C-...-P4S	0.3722	1.7663	3.7221	6.2779	0.6278
2MM307WI	7307C-...-P4S	0.3799	1.8962	3.7990	6.2010	0.6201
2MM308WI	7308C-...-P4S	0.3801	1.9333	4.2025	6.7975	0.6180
2MM309WI	7309C-...-P4S	0.3837	1.9636	3.8373	6.1627	0.6163
2MM310WI	7310C-...-P4S	0.3851	1.9889	3.8510	6.1490	0.6149
2MM311WI	7311C-...-P4S	0.3861	2.0099	3.8606	6.1394	0.6139
2MM312WI	7312C-...-P4S	0.3870	2.0281	3.8704	6.1296	0.6130
2MM313WI	7313C-...-P4S	0.3879	2.0440	4.2665	6.7335	0.6121
2MM314WI	7314C-...-P4S	0.3884	2.0576	4.2729	6.7271	0.6116
2MM319WI	7319C-...-P4S	0.3857	2.0013	3.8570	6.1430	0.6143

<sup>(1)</sup>For inner ring rotation.

<sup>(2)</sup>For outer ring rotation.

## 3MM300WI SERIES (7300E-...-P4S)

**FTF:** Fundamental Train Frequency: the frequency at which the cage will operate.

**BPFO:** Ball Pass Frequency Outer: the frequency at which a single defect in the outer race will be detected.

**BSF:** Ball Spin Frequency: the frequency at which a single defect on a rolling element will be detected.

**BPFI:** Ball Pass Frequency Inner: the frequency at which a single defect in the inner race will be detected.

**TABLE 88.**  
**3MM300WI SERIES (7300E-...-P4S) FREQUENCY COEFFICIENTS**

Bearing Number	Timken ISO Bearing Number	FTF-Inner <sup>(1)</sup>	BSF	BPFO	BPFI	FTF-Outer <sup>(2)</sup>
3MM301WI	7301E-...-P4S	0.3678	1.5949	2.9425	5.0575	0.6322
3MM302WI	7302E-...-P4S	0.3928	2.0149	3.9277	6.0723	0.6072
3MM303WI	7303E-...-P4S	0.3653	1.5578	2.5571	4.4429	0.6347
3MM304WI	7304E-...-P4S	0.3701	1.6268	2.9611	5.0389	0.6299
3MM305WI	7305E-...-P4S	0.3761	1.7147	3.3850	5.6150	0.6239
3MM306WI	7306E-...-P4S	0.3801	1.7811	3.8010	6.1990	0.6199
3MM307WI	7307E-...-P4S	0.3874	1.9101	3.8736	6.1264	0.6126
3MM308WI	7308E-...-P4S	0.3893	1.9469	4.2826	6.7174	0.6107
3MM309WI	7309E-...-P4S	0.3910	1.9772	3.9096	6.0904	0.6090
3MM310WI	7310E-...-P4S	0.3920	2.0019	3.9205	6.0795	0.6080
3MM311WI	7311E-...-P4S	0.3931	2.0231	3.9314	6.0686	0.6069
3MM312WI	7312E-...-P4S	0.3941	2.0412	3.9405	6.0595	0.6059
3MM313WI	7313E-...-P4S	0.3947	2.0567	4.3415	6.6585	0.6053
3MM314WI	7314E-...-P4S	0.3954	2.0705	4.3491	6.6509	0.6046
3MM319WI	7319E-...-P4S	0.3927	2.0144	3.9270	6.0730	0.6073

<sup>(1)</sup>For inner ring rotation.

<sup>(2)</sup>For outer ring rotation.

## BALL SCREW SUPPORT SERIES METRIC SERIES

**FTF:** Fundamental Train Frequency: the frequency at which the cage will operate.

**BSF:** Ball Spin Frequency: the frequency at which a single defect on a rolling element will be detected.

**BPFO:** Ball Pass Frequency Outer: the frequency at which a single defect in the outer race will be detected.

**BPFI:** Ball Pass Frequency Inner: the frequency at which a single defect in the inner race will be detected.

**TABLE 89.  
BSSB METRIC FREQUENCY COEFFICIENTS**

Bearing Number	FTF-Inner <sup>(1)</sup>	BSF	BPFO	BPFI	FTF-Outer <sup>(2)</sup>
MM12BS32	0.4460	2.2827	4.9063	6.0937	0.5540
MM15BS35	0.4525	2.6008	5.8825	7.1175	0.5475
MM17BS47	0.4362	2.1044	5.2349	6.7651	0.5638
MM20BS47	0.4362	2.1044	5.2349	6.7651	0.5638
MM25BS52	0.4423	2.3307	5.7494	7.2506	0.5577
MM25BS62	0.4554	3.0307	7.7410	9.2590	0.5446
MM30BS62	0.4554	3.0307	7.7410	9.2590	0.5446
MM30BS72	0.4569	3.1286	8.2244	9.7756	0.5431
MM35BS72	0.4569	3.1286	8.2244	9.7756	0.5431
MM35BS100	0.4564	3.0983	8.2159	9.7841	0.5436
MM40BS72	0.4569	3.1286	8.2244	9.7756	0.5431
MM40BS90	0.4676	4.1773	11.2230	12.7770	0.5324
MM40BS90-20	0.4676	4.1767	11.2228	12.7772	0.5324
MM40BS90-23	0.4676	4.1767	11.2200	12.7772	0.5324
MM40BS100	0.4564	3.0983	8.2159	9.7841	0.5436
MM45BS75	0.4605	3.4145	9.2094	10.7906	0.5395
MM45BS100	0.4564	3.0983	8.2159	9.7841	0.5436
MM50BS90	0.4676	4.1773	11.2230	12.7770	0.5324
MM50BS100	0.4564	3.0983	8.2159	9.7841	0.5436
MM55BS90	0.4676	4.1773	11.2230	12.7770	0.5324
MM55BS120	0.4644	3.7967	9.7516	11.2484	0.5356
MM60BS120	0.4644	3.7967	9.7516	11.2484	0.5356
MM75BS110	0.4747	5.3492	14.2402	15.7598	0.5253
MM100BS150	0.4790	6.4611	17.7226	19.2774	0.5210

<sup>(1)</sup>For inner ring rotation.

<sup>(2)</sup>For outer ring rotation.

**TABLE 90.  
BSSB INCH FREQUENCY COEFFICIENTS**

Bearing Number	FTF-Inner <sup>(1)</sup>	BSF	BPFO	BPFI	FTF-Outer <sup>(2)</sup>
MM9306WI2H	0.4362	2.1044	5.2349	6.7651	0.5638
MM9308WI2H	0.4554	3.0307	7.7410	9.2590	0.5446
MM9310WI2H	0.4569	3.1286	8.2244	9.7756	0.5431
MM9311WI3H	0.4605	3.4145	9.2094	10.7906	0.5395
MM9313WI5H	0.4676	4.1773	11.2230	12.7770	0.5324
MM9316WI3H	0.4747	5.3492	14.2402	15.7598	0.5253
MM9321WI3	0.4794	6.4615	17.7378	19.2622	0.5206
MM9326WI6H	0.4778	6.1209	16.7239	18.2761	0.5222

<sup>(1)</sup>For inner ring rotation.

<sup>(2)</sup>For outer ring rotation.

# PRECISION TAG DEVIATION AND RUNOUT CHARTS TAPERED ROLLER BEARINGS

Bearing tag markings include indication of bearing accuracy, which can assist with selective assembly and installation. Refer to diagrams on page 99.

**TABLE 91.  
METRIC TAG SYSTEM**

Class	Designation No.	Deviation			
		Over	Incl.	Over	Incl.
		mm		in.	
All	-2	<b>0.000 to -0.002</b>		0.0000 to -0.0001	
	-4	<b>-0.002 to -0.004</b>		-0.0001 to -0.0002	
	-8	<b>-0.004 to -0.008</b>		-0.0002 to -0.0003	
	-12	<b>-0.008 to -0.012</b>		-0.0003 to -0.0004	
	-16	<b>-0.012 to -0.016</b>		-0.0004 to -0.0006	
	-20	<b>-0.016 to -0.020</b>		-0.0006 to -0.0008	
	-25	<b>-0.020 to -0.025</b>		-0.0008 to -0.0010	
	-30	<b>-0.025 to -0.030</b>		-0.0010 to -0.0012	
	-35	<b>-0.030 to -0.035</b>		-0.0012 to -0.0014	
	-40	<b>-0.035 to -0.040</b>		-0.0014 to -0.0016	
	-45	<b>-0.040 to -0.045</b>		-0.0016 to -0.0018	
	-50	<b>-0.045 to -0.050</b>		-0.0018 to -0.0020	
	-55	<b>-0.050 to -0.055</b>		-0.0020 to -0.0022	
	-60	<b>-0.055 to -0.060</b>		-0.0022 to -0.0024	
	-65	<b>-0.060 to -0.065</b>		-0.0024 to -0.0026	
	-70	<b>-0.065 to -0.070</b>		-0.0026 to -0.0028	
-75	<b>-0.070 to -0.075</b>		-0.0028 to -0.0030		
-80	<b>-0.075 to -0.080</b>		-0.0030 to -0.0031		
C & B	2	<b>0.000 to 0.002</b>		0.0000 to 0.0001	
	4	<b>0.002 to 0.004</b>		0.0001 to 0.0002	
	8	<b>0.004 to 0.008</b>		0.0002 to 0.0003	
	12	<b>0.008 to 0.012</b>		0.0003 to 0.0004	
	16	<b>0.012 to 0.016</b>		0.0004 to 0.0006	
	20	<b>0.016 to 0.020</b>		0.0006 to 0.0008	
	25	<b>0.020 to 0.025</b>		0.0008 to 0.0010	
	30	<b>0.025 to 0.030</b>		0.0010 to 0.0012	
	35	<b>0.030 to 0.035</b>		0.0012 to 0.0014	
	40	<b>0.035 to 0.040</b>		0.0014 to 0.0016	
A	45	<b>0.040 to 0.045</b>		0.0016 to 0.0018	
	50	<b>0.045 to 0.050</b>		0.0018 to 0.0020	
	55	<b>0.050 to 0.055</b>		0.0020 to 0.0022	
	60	<b>0.055 to 0.060</b>		0.0022 to 0.0024	
	65	<b>0.060 to 0.065</b>		0.0024 to 0.0026	
	70	<b>0.065 to 0.070</b>		0.0026 to 0.0028	
	75	<b>0.070 to 0.075</b>		0.0028 to 0.0030	
	80	<b>0.075 to 0.080</b>		0.0030 to 0.0031	
A	actual amount	<b>0.0000 to 0.0019</b>		0.00000 to 0.000075	
AA	actual amount	<b>0.0000 to 0.0010</b>		0.00000 to 0.00004	

# PRECISION TAG DEVIATION AND RUNOUT CHARTS – continued

**TABLE 92.  
INCH TAG SYSTEM**

Class	Designation No.	Deviation			
		Over	Incl.	Over	Incl.
		mm		in.	
All	+1	0.000 to 0.003		0.0000 to 0.0001	
	+2	0.003 to 0.005		0.0001 to 0.0002	
	+3	0.005 to 0.008		0.0002 to 0.0003	
	+4	0.008 to 0.010		0.0003 to 0.0004	
	+5	0.010 to 0.013		0.0004 to 0.0005	
	+6	0.013 to 0.015		0.0005 to 0.0006	
	+7	0.015 to 0.018		0.0006 to 0.0007	
	+8	0.018 to 0.020		0.0007 to 0.0008	
	+9	0.020 to 0.023		0.0008 to 0.0009	
	+10	0.023 to 0.025		0.0009 to 0.0010	
	+11	0.025 to 0.028		0.0010 to 0.0011	
	+12	0.028 to 0.030		0.0011 to 0.0012	
	+13	0.030 to 0.033		0.0012 to 0.0013	
	+14	0.033 to 0.036		0.0013 to 0.0014	
	+15	0.036 to 0.038		0.0014 to 0.0015	
	+16	0.038 to 0.041		0.0015 to 0.0016	
	+17	0.041 to 0.043		0.0016 to 0.0017	
	+18	0.043 to 0.046		0.0017 to 0.0018	
	+19	0.046 to 0.048		0.0018 to 0.0019	
	+20	0.048 to 0.051		0.0019 to 0.0020	
	+21	0.051 to 0.053		0.0020 to 0.0021	
	+22	0.053 to 0.056		0.0021 to 0.0022	
	+23	0.056 to 0.058		0.0022 to 0.0023	
	+24	0.058 to 0.061		0.0023 to 0.0024	
	+25	0.061 to 0.064		0.0024 to 0.0025	
	+26	0.064 to 0.066		0.0025 to 0.0026	
	+27	0.066 to 0.069		0.0026 to 0.0027	
	+28	0.069 to 0.071		0.0027 to 0.0028	
	+29	0.071 to 0.074		0.0028 to 0.0029	
	+30	0.074 to 0.076		0.0029 to 0.0030	
3 & 0	+1	0.000 to 0.003		0.0000 to 0.0001	
	+2	0.003 to 0.005		0.0001 to 0.0002	
	+3	0.005 to 0.008		0.0002 to 0.0003	
	+4	0.008 to 0.010		0.0003 to 0.0004	
	+5	0.010 to 0.013		0.0004 to 0.0005	
	+6	0.013 to 0.015		0.0005 to 0.0006	
	+7	0.015 to 0.018		0.0006 to 0.0007	
	+8	0.018 to 0.020		0.0007 to 0.0008	
	+9	0.020 to 0.023		0.0008 to 0.0009	
	+10	0.023 to 0.025		0.0009 to 0.0010	
	+11	0.025 to 0.028		0.0010 to 0.0011	
	+12	0.028 to 0.030		0.0011 to 0.0012	
	+13	0.030 to 0.033		0.0012 to 0.0013	
	+14	0.033 to 0.036		0.0013 to 0.0014	
	+15	0.036 to 0.038		0.0014 to 0.0015	
	+16	0.038 to 0.041		0.0015 to 0.0016	
	+17	0.041 to 0.043		0.0016 to 0.0017	
	+18	0.043 to 0.046		0.0017 to 0.0018	
	+19	0.046 to 0.048		0.0018 to 0.0019	
	+20	0.048 to 0.051		0.0019 to 0.0020	
	+21	0.051 to 0.053		0.0020 to 0.0021	
	+22	0.053 to 0.056		0.0021 to 0.0022	
	+23	0.056 to 0.058		0.0022 to 0.0023	
	+24	0.058 to 0.061		0.0023 to 0.0024	
	+25	0.061 to 0.064		0.0024 to 0.0025	
	+26	0.064 to 0.066		0.0025 to 0.0026	
	+27	0.066 to 0.069		0.0026 to 0.0027	
	+28	0.069 to 0.071		0.0027 to 0.0028	
	+29	0.071 to 0.074		0.0028 to 0.0029	
	+30	0.074 to 0.076		0.0029 to 0.0030	
00	Act. amt. in microinches	0.0000 to 0.0019		0.0000 to 0.000075	
000	Act. amt. in microinches	0.0000 to 0.0010		0.000000 to 0.000040	

## GEOMETRY FACTORS

### TAPERED ROLLER BEARINGS

The tables below list the  $C_g$ ,  $G_1$ ,  $G_2$  and  $K$  factors for tapered roller bearings covered in this catalog. These constants are used in heat generation estimates, influence of application operating speed, and other calculations relating to the bearing's internal geometry details.

**TABLE 93.**  
**TS GEOMETRY FACTORS**

Part Number	$C_g$	$G_1$	$G_2$	$K$
JP6049-JP6010	0.0240	39.5	22.5	1.24
29585-29520	0.0303	70.3	25.8	1.27
JLM710949C-JLM710910	0.0273	55.5	24.5	1.29
399A-394A	0.0260	56.0	21.4	1.45
JP7049-JP7010	0.0264	51.1	31.0	1.27
29685-29620	0.0323	77.7	43.3	1.20
34301-34478	0.0297	69.3	27.0	1.30
JP8049-JP8010	0.0297	69.7	37.4	1.29
JM716649-JM716610	0.0371	117.1	38.4	1.31
497-493	0.0352	104.6	29.3	1.31
JP9049-JP9010	(Call)	83.8	46.1	1.18
LM718947-LM718910	0.0389	124.2	37.6	1.22
JP10044-JP10010	0.0357	104.0	40.9	1.24
JM719149-JM719113	0.0410	150.5	36.1	1.32
JP10049-JP10010	0.0357	104.0	40.9	1.24
52400-52618	0.0450	175.4	41.7	1.23
JM822049-JM822010	0.0474	191.5	45.8	1.18
JLM722948-JLM722912	0.0424	161.0	57.2	1.27
68462-68712	0.0274	163.1	51.7	1.18
JL724348-JL724314	0.0432	170.2	70.6	1.27
JL725346-JL725316	0.0455	186.6	77.7	1.23
JP13049-JP13010	0.0287	192.2	60.3	1.24
JP14049-JP14010	0.0311	219.5	68.2	1.16
36690-36620	0.0544	366.1	152.0	1.59
JL730646-JL730612	0.0542	295.2	104.0	1.27
JP16049-JP16010	0.0346	294.4	123.0	1.20
JP17049-JP17010	0.0266	339.3	147.0	1.27
36990-36920	0.0418	514.8	241.0	1.33
JP18049-JP18010	(Call)	369.2	162.0	1.21
JM736149-JM736110	0.0343	589.4	128.0	1.22
87750-87111	0.0318	574.6	131.0	1.41
67985-67920	0.0401	819.5	172.0	1.15
543085-543114	0.0311	608.5	232.0	1.52

**TABLE 94.**  
**TSF GEOMETRY FACTORS**

Part Number	$C_g$	$G_1$	$G_2$	$K$
2984-2924-B	0.0832	38.2	15.7	1.69
JP6049-JP6010-B	0.0240	39.5	22.5	1.24
3984-3920-B	0.1092	75.2	21.3	1.45
482-472-B	0.1083	77.2	23.0	1.61
566-563-B	0.1167	101.0	24.0	1.61
JP7049-JP7010-B	0.0264	51.1	31.0	1.27
33287-33462-B	0.1162	84.2	24.4	1.34
27690-27620-B	0.1198	98.2	41.8	1.40
42350-42587-B	0.1386	130.0	37.2	1.19
JP8049-JP8010-B	0.0297	69.7	37.4	1.29
JP9049-JB9010-B	(Call)	83.8	46.1	1.18
JP10044-JP10010-B	0.0357	104.0	40.9	1.24
683-672-B	0.1056	182.0	37.2	1.24
JP10049-JP10010-B	0.0357	104.0	40.9	1.24
687-672-B	0.1056	182.0	37.2	1.24
71450-71750-B	0.1156	269.0	45.7	1.40
JP13049-JP13010-B	0.0287	192.2	60.3	1.24
JP14049-JP14010-B	0.0311	219.5	68.2	1.16
JL730646-JL730612-B	0.0542	295.2	104.0	1.27

**TABLE 95.  
CROSSED ROLLER GEOMETRY FACTORS**

Part Number	K
XR496051	0.48
JXR637050	0.45
JXR678054	0.47
JXR652050	0.46
XR678052	0.47
JXR699050	0.45
XR766051	0.45
XR820060	0.46
XR855053	0.45
XR882055	0.44
XR882054	0.44
XR889058	0.44
XR897051	0.43

**TABLE 96.  
HYDRA-RIB GEOMETRY FACTORS**

Part Number	G <sub>1</sub>	G <sub>2</sub>	K
JP5049P-JP5019HR	32.5	6.4	1.65
JP5049P-JP5020HR	32.5	6.4	1.65
JP5049PH-JP5017HR	32.5	6.4	1.65
JP5049PH-JP5020HR	32.5	6.4	1.65
JP7548P-JP7520HR	60.5	23.3	1.52
JP7549P-JP7519HR	60.5	23.3	1.52
JP8548-JP8518HR	86.4	15.7	1.56
JP8549P-JP8519HR	86.4	15.7	1.56
JP10048-JP10019HR	106.0	45.5	1.24
JP10048-JP10019HRA	106.0	45.5	1.24
JP11035-JP11019HR	140.4	56.1	1.63
JP11048-JP11019HR	140.4	56.1	1.63
JP12043P-JP12019HR	172.0	34.6	1.50
JP12049P-JP12019HR	172.0	34.6	1.50
JP13043P-JP13016HR	212.0	39.0	1.50
JP13049P-JP13016HR	212.0	39.0	1.50
JP14043P-JP14019HR	235.0	44.8	1.40
JP14049P-JP14019HR	235.0	44.8	1.40
JP16043P-JP16019HR	319.0	58.9	1.44
JP16049P-JP16019HR	319.0	58.9	1.44
JP17049P-JP17019HR	365.4	62.9	1.50
JP18049P-JP18019HR	397.8	70.2	1.42
JP20049P-JP20019HR	479.5	140.8	1.46
JP22049E-JP22019HR	588.1	184.9	1.33
JL555235-JL55512HR	1305.0	393.0	1.64
JL555239-JL55512HR	1305.0	393.0	1.64



## RADIAL INTERNAL CLEARANCE BALL BEARINGS

Deep groove radial type bearings may be matched to various radial internal clearances to meet specific design and performance requirements. The following chart lists the clearance options available.

Deep groove bearings ordered without a prefix for clearance specification will be supplied with a "P" fit (ISO C3) as standard.

**TABLE 97.  
RADIAL INTERNAL CLEARANCES**

Bore No.	"H" Fit Snug (C2)		"R" Fit Regular (C0)		"P" Fit Loose (C3)-Standard		"J" Fit Extra-Loose (C4)	
	$\mu\text{m}$	0.0000 in.	$\mu\text{m}$	0.0000 in.	$\mu\text{m}$	0.0000 in.	$\mu\text{m}$	0.0000 in.
00	3-8	1-3	5-13	2-5	10-20	4-8	18-25	7-10
01	3-10	1-4	5-15	2-6	13-23	5-9	20-30	8-12
02	3-10	1-4	5-15	2-6	13-23	5-9	20-30	8-12
03	3-10	1-4	5-15	2-6	13-23	5-9	20-30	8-12
04	3-10	1-4	8-18	3-7	15-25	6-10	23-33	9-13
05	3-10	1-4	8-18	3-7	15-25	6-10	25-38	10-15
06	3-10	1-4	8-18	3-7	15-25	6-10	25-38	10-15
07	3-10	1-4	8-18	3-7	18-30	7-12	30-43	12-17
08	3-10	1-4	8-18	3-7	18-30	7-12	30-43	12-17
09	3-10	1-4	8-20	3-8	20-33	8-13	33-48	13-19
10	3-10	1-4	8-20	3-8	20-33	8-13	33-48	13-19
11	3-13	1-5	10-25	4-10	25-40	10-16	40-58	16-23
12	3-13	1-5	10-25	4-10	25-40	10-16	40-58	16-23
13	3-13	1-5	10-25	4-10	25-40	10-16	40-58	16-23
14	3-13	1-5	10-25	5-11	28-48	11-19	48-68	19-27
15	3-13	1-5	13-28	5-11	28-48	11-19	48-68	19-27
16	3-13	1-5	13-28	5-11	28-48	11-19	48-68	19-27
17-20	3-15	1-6	13-28	5-13	33-55	13-22	55-80	22-32
21-24	3-15	1-6	18-38	7-15	38-63	15-25	63-93	25-37
25-28	5-20	2-8	20-45	8-18	43-79	17-31	74-127	29-50

Values shown in micrometers ( $\mu\text{m}$ ) and ten-thousandths inches (0.0001 in.).

## BEARING SPACERS

Spacers are used to increase shaft rigidity, moment stiffness and decrease deflection. Spacers, mounted between units of a pair of bearings, are preferably made of alloy steel, hardened and ground, and should be sturdy in cross section and equal in length. Equal lengths can be produced by grinding the inner-ring spacer and outer-ring spacer together. It is important that the faces of the spacers be square and that their parallelism be the best possible. All corners should be broken to remove sharp edges and burrs.

The inside diameter of the inner-ring spacers should clear the shaft, but not be so loose as to make it possible to mount and run them eccentrically. For short spacers and high operating speeds, clearance

of not more than 0.012mm (0.0005 in.) over the maximum shaft diameter has been found generally acceptable. For long spacers and low speeds, this clearance may be increased to prevent the shaft from disturbing the face parallelism of the spacer. The spacer outside diameter should match the shaft shoulder diameter of the bearing.

The outside diameter of the outer-ring spacers should be about 0.025 mm (0.0010 in.) smaller than the minimum bore of the housing. These should have lubricant holes and grooves where necessary and are usually centrally located.

Spacer end parallelism should be the same as the parallelism tolerance for the adjacent bearing.

## BEARING LOCKNUTS AND TORQUE

To position precision bearings on spindle shafts, precision manufactured self-locking bearing locknuts are suggested rather than the conventional locknuts and lockwashers used for bearings made to ABEC 1/ISO P0 standard class tolerances.

This precision bearing nut incorporates a locking feature in its design. The nut threads deform slightly as the locking setscrews are tightened. This slight deformation creates an interference with the shaft threads which prevents further rotation of the locknut. The precision threads of this locknut are cut square with the face to provide the necessary true-running clamping surface against the inner-ring face of the bearings.

The approximate locknut torque to be used in the application can be estimated using the total clamping force (axial) to be applied to overcome the shaft/bore fit and the bearing preload.

Clamping force,  $F_c$ , can be determined as below:

$$F_c = F_p + 1.25 F_{fmax}$$

$F_p$  = preload force to be applied on the bearing  
(from product tables)

$F_{fmax}$  = Force required to overcome the fit resistance

Preload force to be applied on the bearing:

$$F_p = 3 \cdot F_{cat} \cdot f_p$$

$F_{cat}$  = Catalog preload force for the selected bearing

**TABLE 98.  
PRELOAD FACTORS**

Bearing Arrangement	Preload Factor $f_p$
<>	1.00
<<>	1.33
<<<>	1.50
<<<>>	2.00
<<<<>	1.60
<<<<>>	2.40

Force required to overcome the shaft/bore fit:

$$F_{fmax} = \pi \cdot d \cdot B \cdot p_i \cdot \mu$$

$p_i$  = Interface pressure

$d$  = Nominal bearing bore diameter (from product tables)

$B$  = Bearing width

$\mu$  = Coefficient of friction at shaft/bore interface

For hollow shafts:

$$P_i = \frac{Ei2d}{2d} \left[ \frac{(d_o^2 - d^2)(d^2 - d_i^2)}{d^2(d_o^2 - d_i^2)} \right]$$

For solid shafts:

$$P_i = \frac{Ei}{2d} \left[ 1 - \frac{d^2}{d_o^2} \right]$$

$E$  = Modulus of elasticity of steel (for steel shaft and bearing)

$i$  = Diametral interference

$d_i$  = Inner diameter of the hollow shaft

$$d_o = 0.06D + (f_s - 0.06)d$$

$D$  = Nominal bearing O.D. diameter (from product tables)

$f_s$  = Section factor

**TABLE 99.  
SECTION FACTORS**

d (mm)	Section Factor $f_s$					
	200WI	300WI	9100WI	9300WI	9100HX	9300HX
10 - 20	1.30	1.40	1.27	1.21	1.29	1.27
25 - 150	1.16	1.22	1.12	1.10	1.14	1.10

Estimated locknut torque required to generate the calculated clamping force:

$$\tau = F_c \left[ \frac{d_{pt}}{2} \cdot \frac{\tan\beta + \left(\frac{\mu_t}{\cos\alpha}\right)}{1 - \left(\frac{\mu_t \tan\beta}{\cos\alpha}\right)} + \frac{\mu_f d_{pf}}{2} \right]$$

$d_{pt}$  = Pitch diameter of the locknut thread

$d_{pf}$  = Pitch diameter of the locknut thrust face

$\beta$  = Thread helix angle

$\alpha$  = Half of thread included angle (usually 30°)

$\mu_t$  = Coefficient of friction at the thread contact

$\mu_f$  = Coefficient of friction at the locknut/bearing interface

## LOCKNUT TORQUE<sup>(1)</sup>

### BALL BEARINGS

General guidelines for locknut torques are shown in the table below for dry thread engagement. Bearing locknuts are to be tightened using a torque wrench and a two-point locknut wrench or other suitable torque wrench adapter.

Reference MIL-B-17931

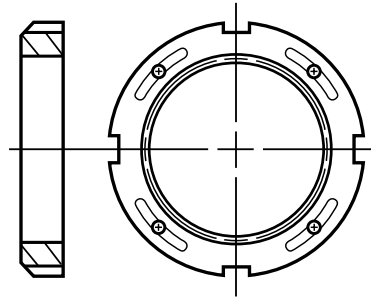

**TABLE 100.**  
**LOCKNUT TORQUES**

Bearing Bore	Locknut Torque <sup>(1)</sup>		Approximate Clamping Force	
	mm	N/m	ft.-lb.	kN
10	14-27	10-20	7.2-14.4	1620-3240
12	14-27	10-20	5.9-11.9	1340-2680
15	14-27	10-20	4.8-9.5	1070-2140
17	14-27	10-20	4.1-8.3	940-1880
20	16-47	12-35	4.2-12.3	950-2770
25	31-68	23-50	6.4-14.1	1450-3170
30	43-81	32-60	7.5-14.1	1690-3710
35	53-95	39-70	7.8-14.0	1750-3140
40	68-108	50-80	8.7-14.0	1970-3140
45	87-122	64-90	9.9-13.9	2220-3120
50	91-136	67-100	9.3-13.9	2090-3120
55	111-169	82-125	10.4-15.7	2330-3540
60	134-203	99-150	11.4-17.3	2560-3880
65	178-237	131-175	13.9-18.6	3130-4190
70	206-271	152-200	14.9-19.7	3360-4430
75	235-339	173-250	16.0-23.2	3610-5220
80	267-373	197-275	17.0-23.8	3840-5350
85	301-441	222-325	18.0-26.4	4060-5940
90	336-508	248-375	19.0-28.8	4280-6480
95	376-576	277-425	20.1-30.9	4520-6950
100	468-644	345-475	23.8-32.8	5360-7380
105	515-746	380-550	25.0-36.1	5620-8120
110	515-746	380-550	23.7-34.4	5340-7740
120	515-746	380-550	21.8-31.5	4900-7080
130	515-746	380-550	20.0-29.1	4510-6540
140	515-746	380-550	18.6-27.0	4190-6070
150	515-746	380-550	17.4-25.2	3910-5660
160	515-746	380-550	16.4-23.7	3680-5330

<sup>(1)</sup>Spindle bearings only. Contact Timken Engineering for use with tapered roller bearings. Valid in all preloaded bearing mounting arrangements.

**LUBRICATION SPECIFICATIONS****BALL BEARINGS**

Timken suggests and provides the following lubricants and rust preservatives with their bearings. Equivalents may be substituted. Note: Rust preservatives are only for temporary storage of the bearings prior to installation.

**QUANTITY OF GREASE**

- 25 percent to 40 percent pack for low to moderate speed (< 500000 dN).
- 10 percent to 15 percent pack for high speed ( $\geq$  500000 dN).

**TABLE 101.  
PREFERRED LUBRICATION TYPES**

Lubrication Code	Lubrication	FS Specification
160	Aeroshell 22	FS381B-P
436	Anticorit L-245XBF	FS890
150	Asonic GLY32	FS889
078 <sup>(1)</sup>	Chevron SRI	FS545
037	Dow Corning 44	FS137A
125	Ferrocote 5856 BF	FS639
181	Ferrocote 5900	FS959
162 <sup>(1)</sup>	Isoflex NBU 15	FS637
443 <sup>(1)</sup>	Isoflex NCA 15	FS905
422	Isoflex SuperLDS18	FS735
115	Isoflex Topas NB52	FS737
149	Isoflex Topas NCA52	FS883
477	Kluberspeed BF72-22	FS934
076	Krytox 240AB	FS452
161	Krytox 240AC	FS433
—	Lubcon L252	FS915
086 <sup>(1)</sup>	Mobil 28	FS381A
456	Mobilith SHC15	FS919
095	Mobiltemp SHC 32	FS612
801	Petamo GHY133N	—
176	Polyrex EM	FS615
457	Thermoplex 2MTL	FS920
052	Unirex N3	FS118 or FS743
167	Windsow Lube L101	FS179A

<sup>(1)</sup>Common suggestions for spindle grease.

Example of lubrication inlet location and direction of lubrication flow.

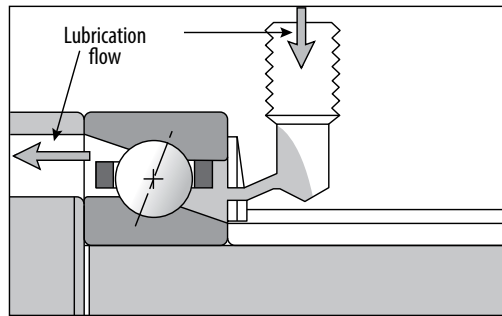

TABLE 102.  
LUBRICATION INLET LOCATION DIAMETERS

Bore No.	9300	9300HX	9100	9100HX	99100	200	300
	mm in.	mm in.	mm in.	mm in.	mm in.	mm in.	mm in.
0	—	15.037 0.592	15.977 0.6290	—	—	17.653 0.6950	—
1	—	17.043 0.6710	18.288 0.7200	—	—	19.456 0.7660	21.641 0.8520
2	19.910 0.7839	20.391 0.8028	21.565 0.8490	—	—	22.479 0.8850	25.705 1.0120
3	21.920 0.8629	22.377 0.8810	23.927 0.9420	—	23.800 0.9370	27.991 1.1020	27.711 1.0910
4	26.563 1.0458	27.254 1.0730	28.448 1.1200	28.296 1.1140	28.143 1.1080	30.201 1.1890	31.313 1.2328
5	30.716 1.2093	32.233 1.2690	33.325 1.3120	33.172 1.3060	33.147 1.3050	35.408 1.3940	38.705 1.5238
6	36.558 1.4393	37.246 1.4660	39.853 1.5690	39.345 1.5490	40.526 1.5955	42.189 1.6610	45.486 1.7908
7	42.743 1.6828	43.599 1.7165	45.314 1.7840	45.339 1.7850	46.177 1.8180	49.047 1.9310	51.722 2.0363
8	48.420 1.9063	48.763 1.9198	50.681 1.9953	50.825 2.0010	52.413 2.0635	54.915 2.1620	58.592 2.3043
9	51.582 2.0308	54.267 2.1365	56.510 2.2248	56.185 2.2120	57.137 2.2495	59.920 2.3590	65.451 2.5768
10	58.415 2.2998	58.783 2.3143	61.514 2.4218	61.163 2.4080	62.141 2.4465	64.897 2.5550	72.321 2.8473
11	64.562 2.5418	64.981 2.5583	68.372 2.6918	69.342 2.7300	69.300 2.7283	71.780 2.8260	79.179 3.1173
12	69.553 2.7383	70.010 2.7563	73.376 2.8888	74.320 2.9260	74.315 2.9258	78.638 3.0960	85.974 3.3848
13	74.582 2.9363	75.001 2.9528	78.379 3.0858	79.019 3.1110	79.294 3.1218	85.827 3.3790	92.895 3.6573
14	81.453 3.2068	81.496 3.2085	85.237 3.3558	86.182 3.3930	86.444 3.4033	90.530 3.5640	99.741 3.9268

Bore No.	9300	9300HX	9100	9100HX	99100	200	300
	mm in.	mm in.	mm in.	mm in.	mm in.	mm in.	mm in.
15	86.444 3.4033	86.939 3.4228	97.112 3.8233	91.186 3.5900	92.489 3.6413	95.529 3.7610	—
16	91.422 3.5993	91.930 3.6193	102.324 4.0285	98.069 3.8610	98.577 3.8810	102.387 4.0310	—
17	98.623 3.8828	99.162 3.9040	102.324 4.0285	—	103.805 4.0868	109.245 4.3010	—
18	103.335 4.0683	103.894 4.0903	108.966 4.2900	110.617 4.3550	110.371 4.3453	116.078 4.5700	—
19	—	108.351 4.2658	113.970 4.4870	—	115.324 4.5403	122.961 4.8410	—
20	—	116.383 4.5820	119.723 4.7135	120.523 4.7450	121.445 4.7813	129.845 5.1120	—
21	—	—	124.866 4.9610	—	134.640 5.3008	137.312 5.4060	—
22	—	125.882 4.9560	132.994 5.2360	135.509 5.3350	144.648 5.6948	143.612 5.6540	—
24	—	138.298 5.4448	143.066 5.6325	144.983 5.7080	—	155.423 6.1190	—
26	—	—	156.743 6.1710	—	160.553 6.3210	162.179 6.3850	—
28	157.442 6.1985	160.256 6.3093	167.005 6.5750	—	—	—	—
30	—	1173.87 6.8453	178.613 7.0320	—	—	198.526 7.8160	—
32	—	—	190.500 7.5000	—	—	—	—
34	—	—	199.746 7.8640	—	—	—	—
40	—	—	241.681 9.5150	—	—	—	—

# OPERATING TEMPERATURES FOR BEARING COMPONENT MATERIALS

These tables provide standard operating temperatures for common bearing component materials. They should be used for reference

purposes only. Other bearing component materials are available on request. Contact your Timken representative for further information.

**TABLE 103.  
COMPONENT MATERIAL OPERATING TEMPERATURES**

Material	Approximate Chemical Analysis %	Temp. °F	Hardness HRC	-73°C -100°F	-54°C -65°F	-17°C 0°F	38°C 100°F	93°C 200°F	121°C 250°F	149°C 300°F	204°C 400°F	260°C 500°F	316°C 600°F	371°C 700°F	427°C 800°F	
Low alloy carbon-chromium bearing steels. 52100 and others per ASTM A295	1C 0.5–1.5Cr 0.35Mn	70	60	STANDARD DIMENSIONAL STABILIZATION <0.0001 in./in dimensional change in 2500 hours at 100°C (212°F). Good oxidation resistance.												
Low alloy carbon-chromium bearing steels. 52100 and others per ASTM A295	1C 0.5–1.5Cr 0.35Mn	70 350 450	58 56 54	Heat stabilized per FS136. When given a stabilizing heat treatment, A295 steel is suitable for many applications in the 177°–232°C (350–450° F) range; however, it is not as stable dimensionally as it is at temperatures below 177°C (350°F). If utmost stability is required, use materials in the 316°C (600°F) group below.												
Deep hardening steels for heavy sections per ASTM A485	1C 1–1.8Cr 1–1.5Mn ,06Si	70 450 600	58 55 52	As heat-treated and tempered, it is stabilized.												
Carburizing steels per ASTM A534 a) low alloy 4118, 8X19, 5019, 8620 (Ni-Moly grades) b) high nickel 3311	Ni-Moly: 0.2C, 0.4–2.0Mn, 0.3–0.8Cr, 0–2.0Ni, 0–0.3Mo ,0.1C, 1.5Cr, 0.4Mn, 3.5Ni	70	58	Nickel-Moly grades of steel frequently used to achieve extra ductility in inner rings for locking device bearings. 3311 and others used for extra-thick-section rings.												
Corrosion resistant 440C stainless steel per ASTM A756	1C 18Cr	70	58	Excellent corrosion resistance.												
Corrosion resistant 440C stainless steel per ASTM A756	1C 18Cr	70 450 600	58 55 52	As heat stabilized for maximum hardness at high temperatures (FS238). Good oxidation resistance at higher temperatures. Note load capacity drops off more rapidly at higher temperatures than M50 shown below, which should be considered if loads are high.												
M-50 medium high speed	4Cr 4Mo 1V 0.8C	70 450 600	60 59 57	Suggested where stable high hardness at elevated temperature is required.												

Bearings have been made of special material for operation at temperatures above 427° C (800° F). Consult your Timken representative regarding the application.  
Note: ASTM A295 bearing steels are suitable for many applications up to 212° C (413° F) but are not as dimensionally stable as they are at the temperatures below 100°C (212°F).

**TABLE 104.**  
**CAGE, SHIELD AND SEAL OPERATING TEMPERATURES**

	-54° C -65° F	-17° C 0° F	38° C 100° F	93° C 200° F	149° C 300° F	204° C 400° F	260° C 500° F	316° C 600° F	371° C 700° F	427° C 800° F
<b>CAGES</b>										
Molded 6/6 Nylon (PRB)										
Molded 6/6 Fiberglass Reinforced Nylon (PRC/PRL)										
Phenolic Resin Laminate										
Low Carbon Pressed Steel										
Pressed Stainless Steel										
Machined Bronze										
Machined Iron-Silicon Bronze										
Machined Steel										
<b>SHIELDS</b>										
Low Carbon Steel										
Stainless Steel										
Nylon										
<b>SEALS</b>										
Buna N										
Polyacrylic										
Fluoroelastomer										
Stabilized TFE Fluorocarbon <sup>(1)</sup>										
TFE Fluorocarbon <sup>(1)</sup> (with glass fabric)										

<sup>(1)</sup>Limited life above these temperatures.

# CONVERSION TABLES

**TABLE 105.**  
**VISCOSITY CONVERSION TABLE**

SUS Saybolt (sec.)	R" Redwood (sec.)	E Engler (deg.)	cSt Centistokes (mm <sup>2</sup> /s)
35	32.2	1.18	2.7
40	36.2	1.32	4.3
45	40.6	1.46	5.9
50	44.9	1.60	7.4
55	49.1	1.75	8.9
60	53.5	1.88	10.4
65	57.9	2.02	11.8
70	62.3	2.15	13.1
75	67.6	2.31	14.5
80	71.0	2.42	15.8
85	75.1	2.55	17.0
90	79.6	2.68	18.2
95	84.2	2.81	19.4
100	88.4	2.95	20.6
110	97.1	3.21	23.0
120	105.9	3.49	25.0
130	114.8	3.77	27.5
140	123.6	4.04	29.8
150	132.4	4.32	32.1
160	141.1	4.59	34.3
170	150.0	4.88	36.5
180	158.8	5.15	38.8
190	167.5	5.44	41.0
200	176.4	5.72	43.2
220	194.0	6.28	47.5
240	212	6.85	51.9
260	229	7.38	56.5
280	247	7.95	60.5
300	265	8.51	64.9
325	287	9.24	70.3
350	309	9.95	75.8
375	331	10.7	81.2
400	353	11.4	86.8
425	375	12.1	92.0
450	397	12.8	97.4
475	419	13.5	103
500	441	14.2	108
550	485	15.6	119
600	529	17.0	130
650	573	18.5	141
700	617	19.9	152
750	661	21.3	163
800	705	22.7	173
850	749	24.2	184
900	793	25.6	195
950	837	27.0	206
1000	882	28.4	217
1200	1058	34.1	260
1400	1234	39.8	302
1600	1411	45.5	347
1800	1587	51	390
2000	1763	57	433
2500	2204	71	542
3000	2646	85	650
3500	3087	99	758
4000	3526	114	867
4500	3967	128	974
5000	4408	142	1082
5500	4849	156	1150
6000	5290	170	1300
6500	5730	185	1400
7000	6171	199	1510
7500	6612	213	1630
8000	7053	227	1740
8500	7494	242	1850
9000	7934	256	1960
9500	8375	270	2070
10000	8816	284	2200

TO CONVERT FROM	TO	MULTIPLY BY
<b>Acceleration</b>		
foot/second <sup>2</sup>	meter/second <sup>2</sup>	m/s <sup>2</sup> ..... 0.3048
inch/second <sup>2</sup>	meter/second <sup>2</sup>	m/s <sup>2</sup> ..... 0.0254
<b>Area</b>		
foot <sup>2</sup>	meter <sup>2</sup>	m <sup>2</sup> ..... 0.09290304
inch <sup>2</sup>	meter <sup>2</sup>	m <sup>2</sup> ..... 0.00064516
inch <sup>2</sup>	millimeter <sup>2</sup>	mm <sup>2</sup> ..... 645.16
yard <sup>2</sup>	meter <sup>2</sup>	m <sup>2</sup> ..... 0.836127
mile <sup>2</sup> (U.S. statute)	meter <sup>2</sup>	m <sup>2</sup> ..... 2589988
<b>Bending Moment or Torque</b>		
dyne-centimeter	newton-meter	N-m ..... 0.000001
kilogram-force-meter	newton-meter	N-m ..... 9.806650
pound-force-inch	newton-meter	N-m ..... 0.1129848
pound-force-foot	newton-meter	N-m ..... 1.355818
<b>Energy</b>		
BTU (International Table)	joule	J ..... 1055.056
foot-pound-force	joule	J ..... 1.355818
kilowatt-hour	megajoule	MJ ..... 3.6
<b>Force</b>		
kilogram-force	newton	N ..... 9.806650
kilopound-force	newton	N ..... 9.806650
pound-force (lbf avoirdupois)	newton	N ..... 4.448222
<b>Length</b>		
fathom	meter	m ..... 1.8288
foot	meter	m ..... 0.3048
inch	millimeter	mm ..... 25.4
microinch	micrometer	µm ..... 0.0254
micron (µm)	millimeter	mm ..... 0.0010
mile (U.S. statute)	meter	m ..... 1609.344
yard	meter	m ..... 0.9144
nautical mile (UK)	meter	m ..... 1853.18
<b>Mass</b>		
kilogram-force-second <sup>2</sup> /meter (mass)	kilogram	kg ..... 9.806650
kilogram-mass	kilogram	kg ..... 1.0
pound-mass (lbm avoirdupois)	kilogram	kg ..... 0.4535924
ton (long, 2240 lbm)	kilogram	kg ..... 1016.047
ton (short, 2000 lbm)	kilogram	kg ..... 907.1847
tonn.	kilogram	kg ..... 1000.000
<b>Power</b>		
BTU (International Table)/hour	watt	W ..... 0.293071
BTU (International Table)/minute	watt	W ..... 17.58427
horsepower (550 ft lbf/s)	kilowatt	kW ..... 0.745700
BTU (thermochemical)/minute	watt	W ..... 17.57250
<b>Pressure or Stress (Force/Area)</b>		
newton/meter <sup>2</sup>	pascal	Pa ..... 1.0000
kilogram-force/centimeter <sup>2</sup>	pascal	Pa ..... 98066.50
kilogram-force/meter <sup>2</sup>	pascal	Pa ..... 9.806650
kilogram-force/millimeter <sup>2</sup>	pascal	Pa ..... 9806650
pound-force/foot <sup>2</sup>	pascal	Pa ..... 47.88026
pound-force/inch <sup>2</sup> (psi)	megapascal	MPa ..... 0.006894757
<b>Temperature</b>		
degree Celsius	kelvin	k ..... t <sub>k</sub> = t <sub>c</sub> + 273.15
degree Fahrenheit	kelvin	k ..... k = 5/9 (t <sub>f</sub> + 459.67)
degree Fahrenheit	Celsius	°C ..... t <sub>c</sub> = 5/9 (t <sub>f</sub> - 32)
<b>Velocity</b>		
foot/minute	meter/second	m/s ..... 0.00508
foot/second	meter/second	m/s ..... 0.3048
inch/second	meter/second	m/s ..... 0.0254
kilometer/hour	meter/second	m/s ..... 0.27778
mile/hour (U.S. statute)	meter/second	m/s ..... 0.44704
mile/hour (U.S. statute)	kilometer/hour	km/h ..... 1.609344
<b>Volume</b>		
foot <sup>3</sup>	meter <sup>3</sup>	m <sup>3</sup> ..... 0.02831685
gallon (U.S. liquid)	liter	l ..... 3.785412
liter	meter <sup>3</sup>	m <sup>3</sup> ..... 0.001
inch <sup>3</sup>	meter <sup>3</sup>	m <sup>3</sup> ..... 0.00001638706
inch <sup>3</sup>	centimeter <sup>3</sup>	cm <sup>3</sup> ..... 16.38706
inch <sup>3</sup>	millimeter <sup>3</sup>	mm <sup>3</sup> ..... 16387.06
ounce (U.S. fluid)	centimeter <sup>3</sup>	cm <sup>3</sup> ..... 29.57353
yard <sup>3</sup>	meter <sup>3</sup>	m <sup>3</sup> ..... 0.7645549



**INDEX**

<b>ITEM</b>	<b>PRODUCT DESCRIPTION</b>	<b>PAGE</b>
BSBU* SERIES	Ball Bearing	200-203
BSPB* SERIES	Ball Bearing	204-207
BALL SCREW SUPPORT SERIES	Ball Bearing	194-199
EX-CELL-O SERIES	Ball Bearing	212-213
JL***	Tapered Roller Bearing	104-105, 108-109, 116-117
JLM***	Tapered Roller Bearing	104-105
JM***	Tapered Roller Bearing	104-105
JP***	Tapered Roller Bearing	104-105, 108-109, 114-115
JXR***	Tapered Roller Bearing	112-113
LM***	Tapered Roller Bearing	106-107
MM200K SERIES	Ball Bearing	184-185
MV/MM200WI SERIES	Ball Bearing	174-183
MM300K SERIES	Ball Bearing	192-193
MM300WI SERIES	Ball Bearing	186-191
MMF SERIES	Ball Bearing	208-209
MMN SERIES	Ball Bearing	210-211
MM9100K SERIES	Ball Bearing	172-173
MV/MM9100WI SERIES	Ball Bearing	152-161
MV/MM9300WI SERIES	Ball Bearing	132-141
MMV9100HX SERIES	Ball Bearing	162-171
MMV9300HX SERIES	Ball Bearing	142-151
TS STYLE	Tapered Roller Bearing	104-107
TSF STYLE	Tapered Roller Bearing	108-111
TSHR STYLE	Tapered Roller Bearing	114-117
TXR STYLE	Tapered Roller Bearing	112-113
XR***	Tapered Roller Bearing	113











To view more Timken catalogs, go to [www.timken.com/catalogs](http://www.timken.com/catalogs) for interactive versions, or to download a catalog app for your smartphone or mobile device scan the QR code or go to [timkencatalogs.squawqr.com](http://timkencatalogs.squawqr.com).

# TIMKEN

The Timken team applies their know-how to improve the reliability and performance of machinery in diverse markets worldwide. The company designs, makes and markets bearings, gear drives, automated lubrication systems, belts, brakes, clutches, chain, couplings, linear motion products and related industrial motion rebuild and repair services.

**Stronger. By Design.**

[www.timken.com](http://www.timken.com)