

# TIMKEN

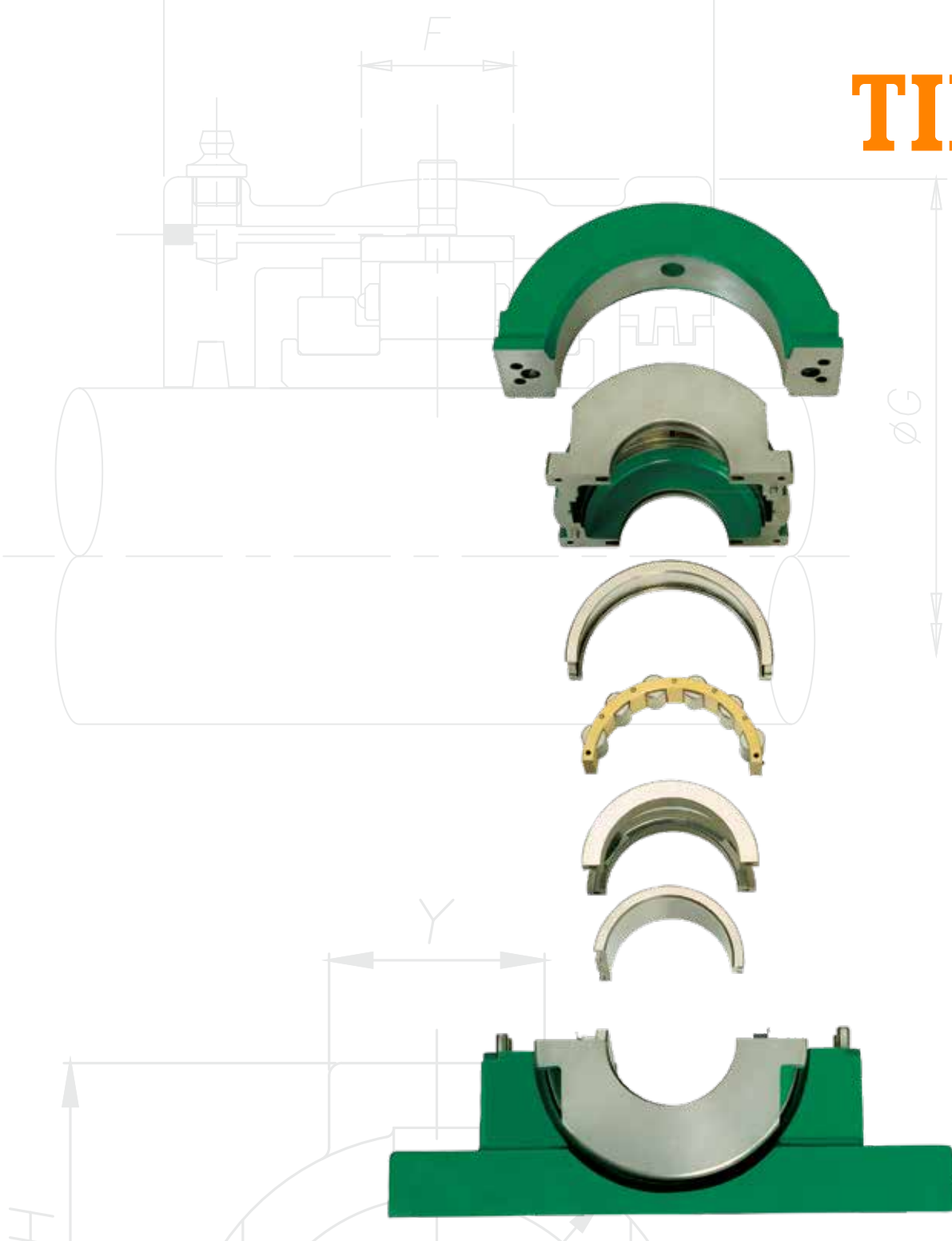

## TIMKEN® MOUNTED SPLIT CYLINDRICAL ROLLER BEARING CATALOG





## **ABOUT THE TIMKEN COMPANY**

As a global leader in bearings and industrial motion, Timken focuses on precise solution design, materials and craftsmanship to deliver reliable and efficient performance that improves productivity and uptime. Timken offers a full range of bearings, belts, chains, couplings, gears and lubricants, along with rebuild and repair services. Timken (NYSE; TKR; [www.timken.com](http://www.timken.com)) applies its proven expertise in metallurgy, tribology and industrial motion to create innovative approaches to customers' complex needs. Global availability of products and engineering talent, combined with exceptional service delivery across markets, makes Timken a preferred choice worldwide.

To view more Timken catalogs, go to [www.timken.com/catalogs](http://www.timken.com/catalogs) for interactive versions, or to download our catalog app to your smartphone or mobile device.



## **TIMKEN® MOUNTED SPLIT CYLINDRICAL ROLLER BEARING CATALOG INDEX**

|                              |   |
|------------------------------|---|
| INTRODUCTION.....            | 2 |
| HOW TO USE THIS CATALOG..... | 5 |
| SHELF LIFE/ STORAGE.....     | 6 |
| WARNINGS.....                | 8 |

### **ENGINEERING**

|                                                       |    |
|-------------------------------------------------------|----|
| Standard Unit Anatomy.....                            | 10 |
| Technical Features.....                               | 11 |
| Industry Applications.....                            | 12 |
| Nomenclature.....                                     | 13 |
| Quick Reference Tables.....                           | 14 |
| Bearing Types.....                                    | 16 |
| Support Types.....                                    | 17 |
| Series Comparison.....                                | 18 |
| Bearing Selection.....                                | 19 |
| Bearings Ratings.....                                 | 22 |
| Axial Considerations.....                             | 24 |
| Bearing Clearance and Temperature Considerations..... | 25 |
| Support Loads and Bearing Frequencies.....            | 25 |
| Bearing Frequency Tables.....                         | 26 |
| Shaft Considerations.....                             | 28 |
| Sealing Arrangements.....                             | 29 |
| Triple Labyrinth Housing and Seal References.....     | 32 |
| Bearing Lubrication.....                              | 35 |
| Assembly and Maintenance.....                         | 36 |
| Screw Sizes, Key Sizes and Torque Values.....         | 40 |
| Shipping Weights.....                                 | 43 |
| Mounted Bearing Conversion Worksheet.....             | 44 |

### **PRODUCT DATA TABLES**

|                         |    |
|-------------------------|----|
| Light Series.....       | 45 |
| Medium Series.....      | 59 |
| Heavy Series.....       | 71 |
| SAF/SN/SD Bearings..... | 77 |

## **TAKING THE INITIATIVE**

In today's demanding industrial environment, specialist technology is, more than ever, key to improved efficiency, productivity and ultimately profitability. Timken is increasingly seen as a product brand, that routinely challenges technological boundaries.

Rapid response and flexibility result from a production facility manufacturing not only split cylindrical roller bearing assemblies but also cutting edge products for aerospace and railway. The unique relationship between manufacturer and distributors combined with innovative cellular manufacturing and modular stocking offer unparalleled availability.

From concept to design, design to production, and then throughout the life cycle of the unit, no other split bearing manufacturer works so hard to exceed your expectations.

## **PERFORMANCE**

Timken products are designed and developed to maximize service life and minimize maintenance effort.

Timken bearings have machined brass cages with unique single-piece clips as standard; rolling elements are profiled to minimize damaging edge stresses and provide optimum rolling contact.

All supports and housings incorporate pry slots and doweled machined joints for easy separation. Supports are manufactured from high-strength cast iron and feature double webs and thick sections. Product life is thus enhanced due to high rigidity and inherent strength.

## **INNOVATION IN SERVICE**

Producing products that push the boundaries of performance is only the beginning. Timken recognizes that users and specifiers of split cylindrical roller bearings demand logistical, technical and after-sales support.

Experienced application engineering support assists customers with concepts through consultation, commissioning, training, supply and post installation support.

Regional inventory provides excellent availability of product in the right place at the right time.



## **INNOVATION IN APPLICATION**

The benefits of totally split-to-the-shaft bearing assemblies are long-established; subsequent savings in production and maintenance are well documented.

However, split cylindrical roller bearings are today being selected for an even wider range of applications. Additional sealing options allow our bearings to run at higher speeds and temperatures in increasingly more hostile environments.

Optimization of plant efficiency is the goal of today's maintenance engineer. The application of reliable products offering real savings is derived from increased mean time between failures. This widens periods between planned shutdowns and also eliminates unplanned downtime when utilizing advanced components accommodating split options.

## **ADVANTAGES OF MOUNTED SPLIT CYLINDRICAL ROLLER BEARINGS**

Split cylindrical roller bearings are essential in applications involving limited access and are highly cost effective by reducing down time and production losses during change-outs.

Split cylindrical roller bearings are completely split to the shaft. Installation and inspection times are therefore dramatically less than for solid bearings. Additionally, the time saved and costs eliminated by not having to remove ancillary equipment results in even higher potential savings.

### **INSPECTION SIMPLIFIED**

No matter what the size or type of split cylindrical roller bearing, inspection is straightforward. Simply remove the support cap and the top half of the housing and all bearing parts become visible and accessible.

### **SHORT TERM PAYBACK, LONG TERM BENEFITS**

Though it would be easy to cite examples where the use of split bearings results in spectacular savings, significant savings can be seen in almost any trapped application. Even modest savings can be enough to justify the use of split bearings. Depending on the application, down times for replacement of split bearings can be a small fraction of those required for solid bearings. This yields savings in both maintenance work-hours and lost production.

When such cost savings are taken into account at the bearing selection stage, it's easy to make the case for choosing Timken split cylindrical roller bearings.

### **FURTHER SAVINGS**

Anywhere Timken bearings are used to replace other split bearing brands, the potential for savings exists. Through the use of machined brass cages as standard, inclusion of profiled rolling elements and the incorporation of high-grade materials for housings and supports, Timken bearings have the capability to extend service life leading to a reduction in bearing consumption.

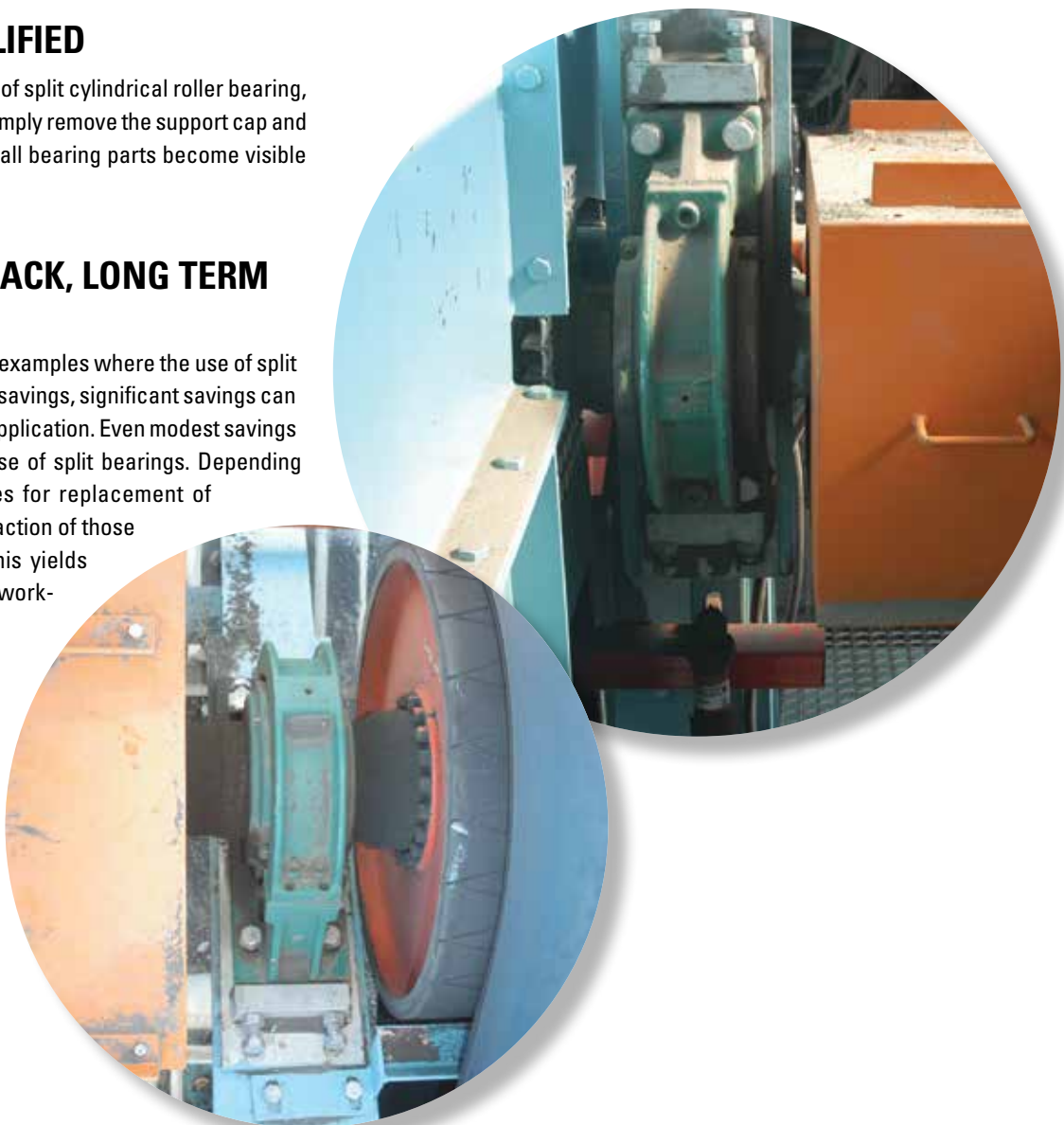

## FEATURES AND BENEFITS

**TABLE 1. MOUNTED SPLIT CYLINDRICAL ROLLER BEARING FEATURES AND BENEFITS**

| Features                                                     | Benefits                                                                                                 |
|--------------------------------------------------------------|----------------------------------------------------------------------------------------------------------|
| All components are totally split to the shaft                | Quick and easy installation. Substantial reduction in downtime compared to replacement of solid bearings |
| Support caps and housing halves are quickly removed          | Easy visual inspection to assess the condition of the bearing (during planned maintenance)               |
| Replacement bearing interchangeability with existing housing | Simple and economic bearing replacement                                                                  |
| Unit accommodates initial misalignment                       | Simplifies installation of associated equipment                                                          |
| Machined brass cage as standard                              | Enhanced ability to accommodate higher speeds and temperatures                                           |
| Innovative cage clip design                                  | Clips retained on one cage half during assembly and disassembly                                          |
| ASTM 48A – Grade 35 Cast Iron                                | Strength and durability                                                                                  |
| Profiled rolling elements                                    | Minimizes damaging edge stresses                                                                         |



## HOW TO USE THIS CATALOG

We designed this catalog to help you find the Timken bearings best suited to your equipment needs and specifications.

The product tables list mounted split bearings and components. For other bearing types, please refer to the respective Timken product catalog reference.

Timken offers an extensive range of bearings and accessories in both imperial and metric sizes. For your convenience, size ranges are indicated in millimeters and inches. Contact your Timken engineer to learn more about our complete line for the special needs of your application.

This publication contains dimensions, tolerances and load ratings, as well as engineering sections describing mounting and fitting practices for shafts and housings, internal clearances, materials and other bearing features. It provides valuable assistance in the initial consideration of the type and characteristics of the bearings that may best suit your particular needs.

ISO and ANSI/ABMA, as used in this publication, refer to the International Organization for Standardization and the American National Standards Institute/American Bearing Manufacturers Association.

Updates are made periodically to this catalog. Visit [www.timken.com](http://www.timken.com) for the most recent version of the Timken Mounted Split Cylindrical Roller Bearing Catalog.

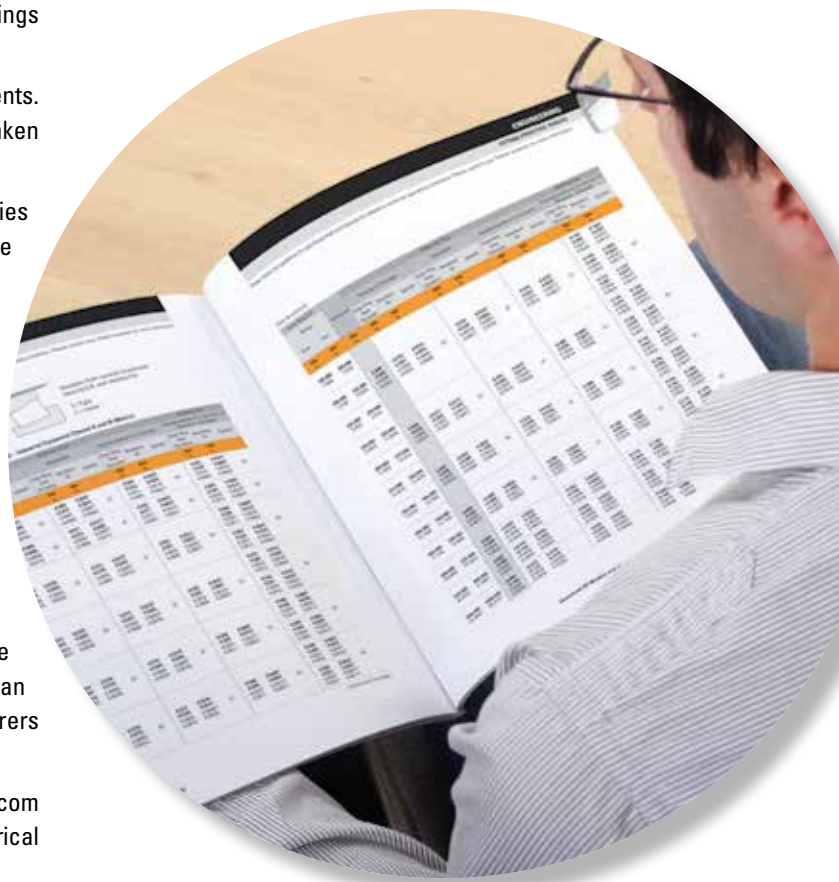

## ***SHELF LIFE AND STORAGE OF GREASE-LUBRICATED BEARINGS AND COMPONENTS***

To help you get the most value from our products, Timken provides guidelines for the shelf life of grease-lubricated ball and roller bearings, components and assemblies. Shelf life information is based on Timken and industry test data and experience.

### **SHELF LIFE**

Shelf life should be distinguished from lubricated bearing/component design life as follows:

- Shelf life of the grease-lubricated bearing/component represents the period of time prior to use or installation.
- The shelf life is a portion of the anticipated aggregate design life. It is impossible to accurately predict design life due to variations in lubricant bleed rates, oil migration, operating conditions, installation conditions, temperature, humidity and extended storage.
- Shelf life values, available from Timken, represent a maximum limit and assume adherence to the storage and handling guidelines suggested in this catalog or by a Timken associate. Deviation from the Timken storage and handling guidelines may reduce shelf life. Any specification or operating practice that defines a shorter shelf life should be used.

Timken cannot anticipate the performance of the grease lubricant after the bearing or component is installed or placed in service.

**TIMKEN IS NOT RESPONSIBLE FOR THE SHELF LIFE OF ANY BEARING/COMPONENT LUBRICATED BY ANOTHER PARTY.**

**MOUNTED SPLIT CYLINDRICAL ROLLER BEARINGS ARE NOT SHIPPED PRE-GREASED.**

### **EUROPEAN REACH COMPLIANCE**

Timken lubricants, greases and similar products sold in stand alone containers or delivery systems are subject to the European REACH (Registration, Evaluation, Authorization and Restriction of Chemicals) directive. For import into the European Union, Timken can sell and provide only those lubricants and greases that are registered with ECHA (European Chemicals Agency). For further information, please contact your Timken engineer.





## STORAGE

Timken suggests the following storage guidelines for our finished products (bearings, components and assemblies, referred to as “products”):

- Unless directed otherwise by Timken, products should be kept in their original packaging until they are ready to be placed into service.
- Do not remove or alter any labels or stencil markings on the packaging.
- Products should be stored in such a way that the packaging is not pierced, crushed or otherwise damaged.
- After a product is removed from its packaging, it should be placed into service as soon as possible.
- When removing a product that is not individually packaged from a bulk pack container, the container should be resealed immediately after the product is removed.
- Do not use product that has exceeded its shelf life as defined in the Timken shelf life guidelines statement.
- The storage area temperature should be maintained between 0° C (32° F) and 40° C (104° F); temperature fluctuations should be minimized.
- The relative humidity should be maintained below 60 percent and the surfaces should be dry.
- The storage area should be kept free from airborne contaminants such as, but not limited to, dust, dirt, harmful vapors, etc.
- The storage area should be isolated from undue vibration.
- Extreme conditions of any kind should be avoided.

Due to the fact that Timken is not familiar with your particular

storage conditions, we strongly suggest following these guidelines. However, you may be required by circumstances or applicable government requirements to adhere to stricter storage requirements.

Most bearing components typically ship protected with a corrosion-preventive compound that is not a lubricant. These components may be used in oil-lubricated applications without removal of the corrosion-preventive compound. When using some specialized grease lubrications, we advise you to remove the corrosion-preventive compound before packing the bearing components with suitable grease.

When you receive a bearing or mounted bearing shipment, do not remove products from their packaging until they are ready for mounting so they do not become corroded or contaminated.

Store bearings and mounted bearings in an appropriate atmosphere so they remain protected for the intended period.

## WARNINGS



### WARNING

**Failure to observe the following warnings could create a risk of death or serious injury.**

Proper maintenance and handling practices are critical. Always follow installation instructions and maintain proper lubrication.

Overheated bearings can ignite explosive atmospheres. Special care must be taken to properly select, install, maintain, and lubricate mounted bearings that are used in or near atmospheres that may contain explosive levels of combustible gases or accumulations of dust such as grain, coal, or other combustible materials.

Never spin a bearing with compressed air. The components may be forcefully expelled.



### CAUTION

**Failure to follow these cautions may result in property damage.**

Do not use damaged mounted bearings.

When fitting the inner ring there should be an equal gap at each joint. If there are no gaps do not proceed.

### NOTE

*Do not use excessive force when mounting or dismounting the unit.*

*Follow all tolerance, fit, and torque recommendations.*

*Ensure proper alignment.*

*Never weld mounted bearings.*

*Do not heat components with an open flame.*

*Do not operate at bearing temperatures above 121° C (250° F).*

*Never interchange components between completed bearing assemblies.*

*Never use a hammer and steel bar on a bearing for installation or removal. Use only a brass bar or a soft-headed mallet.*

*Consult your equipment designer or supplier for installation and maintenance instructions.*

*Never use steam or hot water when cleaning the bearings because these methods can create rust or corrosion.*

*Never expose any surface of a bearing to the flame of a torch.*

*Do not heat bearing beyond 149° C (300° F).*

### DISCLAIMER

***This catalog is provided solely to give you analysis tools and data to assist you in your product selection. Product performance is affected by many factors beyond the control of Timken. Therefore, you must validate the suitability and feasibility of all product selections.***

***Timken products are sold subject to the Timken terms and Conditions of Sale, which include our limited warranty and remedy. You can find these at <https://www.timken.com/legal/notices/termsandconditionsofsale/>.***

***Please consult with your Timken engineer for more information and assistance. Every reasonable effort has been made to ensure the accuracy of the information in this writing, but no liability is accepted for errors, omissions or for any other reason.***

**Warnings for this product line are in this catalog and posted on <http://www.timken.com/legal-notices/>**



## **ENGINEERING**

The following topics are covered within this section:

|                                                            |    |
|------------------------------------------------------------|----|
| Standard Unit Anatomy . . . . .                            | 10 |
| Technical Features . . . . .                               | 11 |
| Industry Applications . . . . .                            | 12 |
| Nomenclature . . . . .                                     | 13 |
| Quick Reference Tables . . . . .                           | 14 |
| Bearing Types . . . . .                                    | 16 |
| Support Types . . . . .                                    | 17 |
| Series Comparison . . . . .                                | 18 |
| Bearing Selection . . . . .                                | 19 |
| Bearings Ratings . . . . .                                 | 22 |
| Axial Considerations . . . . .                             | 24 |
| Bearing Clearance and Temperature Considerations . . . . . | 25 |
| Support Loads and Bearing Frequencies . . . . .            | 25 |
| Bearing Frequency Tables . . . . .                         | 26 |
| Shaft Considerations . . . . .                             | 28 |
| Sealing Arrangements . . . . .                             | 29 |
| Triple Labyrinth Housing and Seal References . . . . .     | 32 |
| Bearing Lubrication . . . . .                              | 35 |
| Assembly And Maintenance . . . . .                         | 36 |
| Screw Sizes, Key Sizes and Torque Values . . . . .         | 40 |
| Shipping Weights . . . . .                                 | 43 |
| Mounted Bearing Conversion Worksheet . . . . .             | 44 |

# STANDARD UNIT ANATOMY

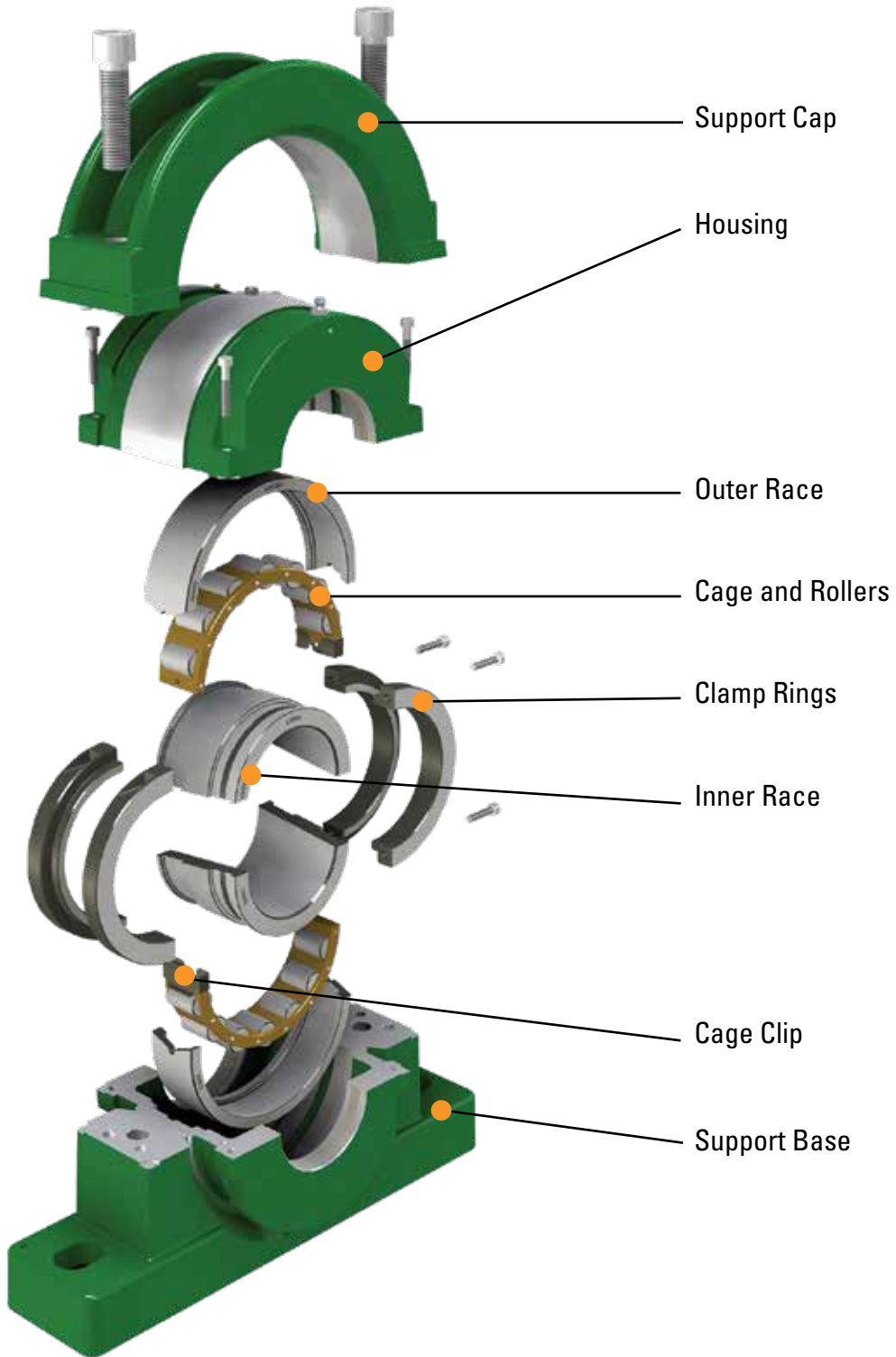

Fig. 1. Standard unit anatomy.

**TECHNICAL FEATURES**

Fig. 2. Technical features.

**INDUSTRY APPLICATIONS**

**TABLE 2. APPLICATIONS**

| Application                  | Target Markets |                    |                        |                 |                          |                |        |        |                    |                  |              |                      |       |                 |
|------------------------------|----------------|--------------------|------------------------|-----------------|--------------------------|----------------|--------|--------|--------------------|------------------|--------------|----------------------|-------|-----------------|
|                              | Bulk Terminals | Cement & Aggregate | Construction Materials | Food & Beverage | Forest Products & Timber | Grains & Malts | Metals | Marine | Mining & Quarrying | Power Generation | Pulp & Paper | Refining & Petrochem | Sugar | Water Treatment |
| <b>Ancillary Equipment</b>   |                |                    |                        |                 |                          |                |        |        |                    |                  |              |                      |       |                 |
| Crankshafts                  |                | X                  |                        |                 |                          |                | X      |        | X                  |                  |              |                      |       |                 |
| Fans & Blowers               |                | X                  | X                      | X               | X                        | X              | X      |        | X                  | X                | X            |                      | X     |                 |
| Gearboxes & Transmissions    | X              | X                  |                        | X               | X                        | X              | X      |        | X                  | X                | X            |                      | X     |                 |
| Heat Exchangers              |                |                    |                        |                 |                          |                |        |        |                    | X                |              |                      |       |                 |
| Motors                       |                | X                  |                        |                 |                          |                | X      |        | X                  | X                | X            |                      |       |                 |
| Pumps & Pump Drives          |                | X                  |                        |                 |                          |                |        | X      | X                  | X                |              |                      |       | X               |
| <b>Mechanical Handling</b>   |                |                    |                        |                 |                          |                |        |        |                    |                  |              |                      |       |                 |
| Continuous Casters           |                |                    |                        |                 |                          |                | X      |        |                    |                  |              |                      |       |                 |
| Conveyors                    | X              | X                  | X                      | X               | X                        | X              | X      |        | X                  | X                | X            |                      | X     |                 |
| Cooling Beds                 |                |                    |                        |                 |                          |                | X      |        |                    |                  |              |                      |       |                 |
| Elevators                    | X              | X                  | X                      |                 |                          |                | X      |        |                    |                  |              |                      | X     |                 |
| Line Shafting                |                |                    | X                      |                 |                          |                | X      |        |                    |                  | X            |                      |       |                 |
| Lumber Tables & Stackers     |                |                    |                        |                 | X                        |                |        |        |                    |                  | X            |                      |       |                 |
| Overhead Cranes              |                |                    | X                      |                 |                          |                | X      |        |                    |                  | X            |                      |       |                 |
| Screw Conveyors              |                | X                  | X                      |                 |                          |                | X      |        |                    | X                | X            | X                    |       | X               |
| Bucket Wheels                | X              |                    |                        |                 |                          |                | X      |        | X                  | X                |              |                      |       |                 |
| Stacker Reclaimers           | X              |                    |                        |                 |                          |                | X      |        | X                  | X                |              |                      |       |                 |
| <b>Process Equipment</b>     |                |                    |                        |                 |                          |                |        |        |                    |                  |              |                      |       |                 |
| Ball Mill Drives             |                | X                  | X                      |                 |                          |                | X      |        | X                  | X                |              |                      |       |                 |
| Ball Mill Trunnions          |                | X                  | X                      |                 |                          |                | X      |        | X                  | X                |              |                      |       |                 |
| Cane Knives & Slicers        |                |                    |                        |                 |                          |                |        |        |                    |                  |              |                      | X     |                 |
| Crushers                     |                | X                  | X                      |                 |                          |                | X      |        | X                  | X                |              |                      |       |                 |
| Drum Drier Trunnions         |                | X                  |                        |                 |                          |                |        |        |                    |                  |              | X                    | X     |                 |
| Dryer Rolls                  |                |                    |                        |                 |                          |                |        |        |                    |                  | X            |                      |       |                 |
| Kiln & Mill Carrier Rollers  |                | X                  |                        |                 |                          |                |        |        | X                  |                  |              |                      | X     |                 |
| Kiln & Mill Drives           |                | X                  |                        |                 |                          |                |        |        |                    |                  |              | X                    | X     |                 |
| Mixer Drives                 |                | X                  | X                      | X               |                          |                | X      |        |                    |                  | X            | X                    |       |                 |
| Press Rolls                  |                |                    | X                      |                 |                          |                |        |        |                    |                  | X            |                      |       |                 |
| Rotary Screens               |                |                    |                        |                 |                          |                |        |        |                    |                  | X            |                      |       | X               |
| Shredders                    |                |                    |                        |                 |                          |                |        |        |                    | X                | X            |                      | X     |                 |
| Sugar Diffuser Drives        |                |                    |                        |                 |                          |                |        |        |                    |                  |              |                      | X     |                 |
| Sugar Diffuser Under Rolls   |                |                    |                        |                 |                          |                |        |        |                    |                  |              |                      | X     |                 |
| Washers                      |                | X                  |                        | X               |                          |                |        |        | X                  |                  | X            |                      | X     |                 |
| <b>Other Applications</b>    |                |                    |                        |                 |                          |                |        |        |                    |                  |              |                      |       |                 |
| Hydro Electric Turbines      |                |                    |                        |                 |                          |                |        |        |                    | X                |              |                      |       |                 |
| Rotary Biological Contactors |                |                    |                        |                 |                          |                |        |        |                    |                  |              |                      |       | X               |
| Mine Winders                 |                |                    |                        |                 |                          |                |        |        |                    | X                |              |                      |       |                 |
| Marine Propulsion Shafts     |                |                    |                        |                 |                          |                |        | X      |                    |                  |              |                      |       |                 |
| Water Treatment Screens      |                |                    |                        |                 |                          |                |        |        |                    |                  | X            |                      |       | X               |
| Water Treatment Aerators     |                |                    |                        |                 |                          |                |        |        |                    |                  |              |                      |       | X               |

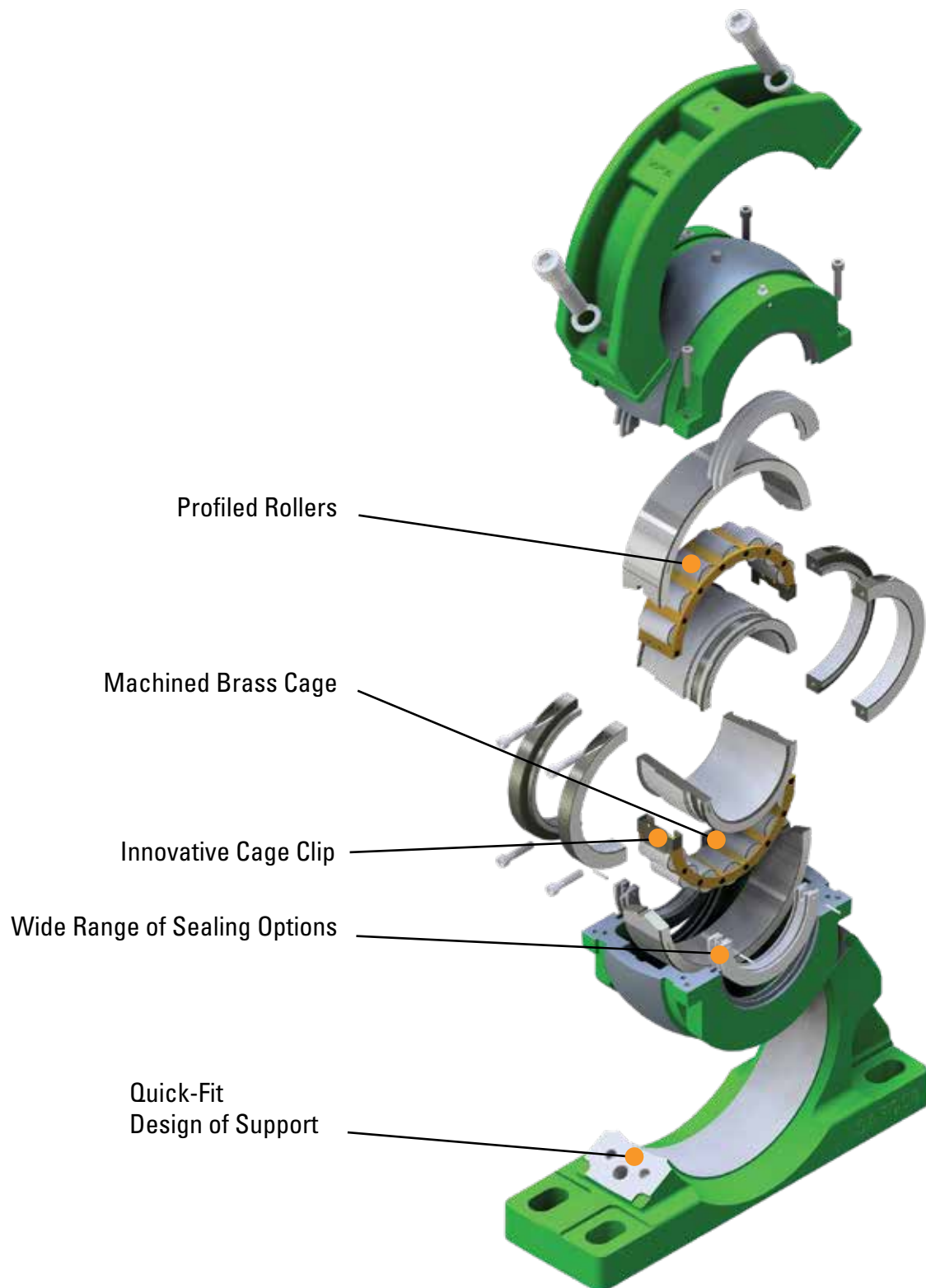
## NOMENCLATURE

In order to provide our customers with clear and concise labeling, Timken has endeavored to keep things simple when creating references. The following should cover the majority of ordering

situations however, as always, your local Timken engineer will be pleased to provide further assistance if required.

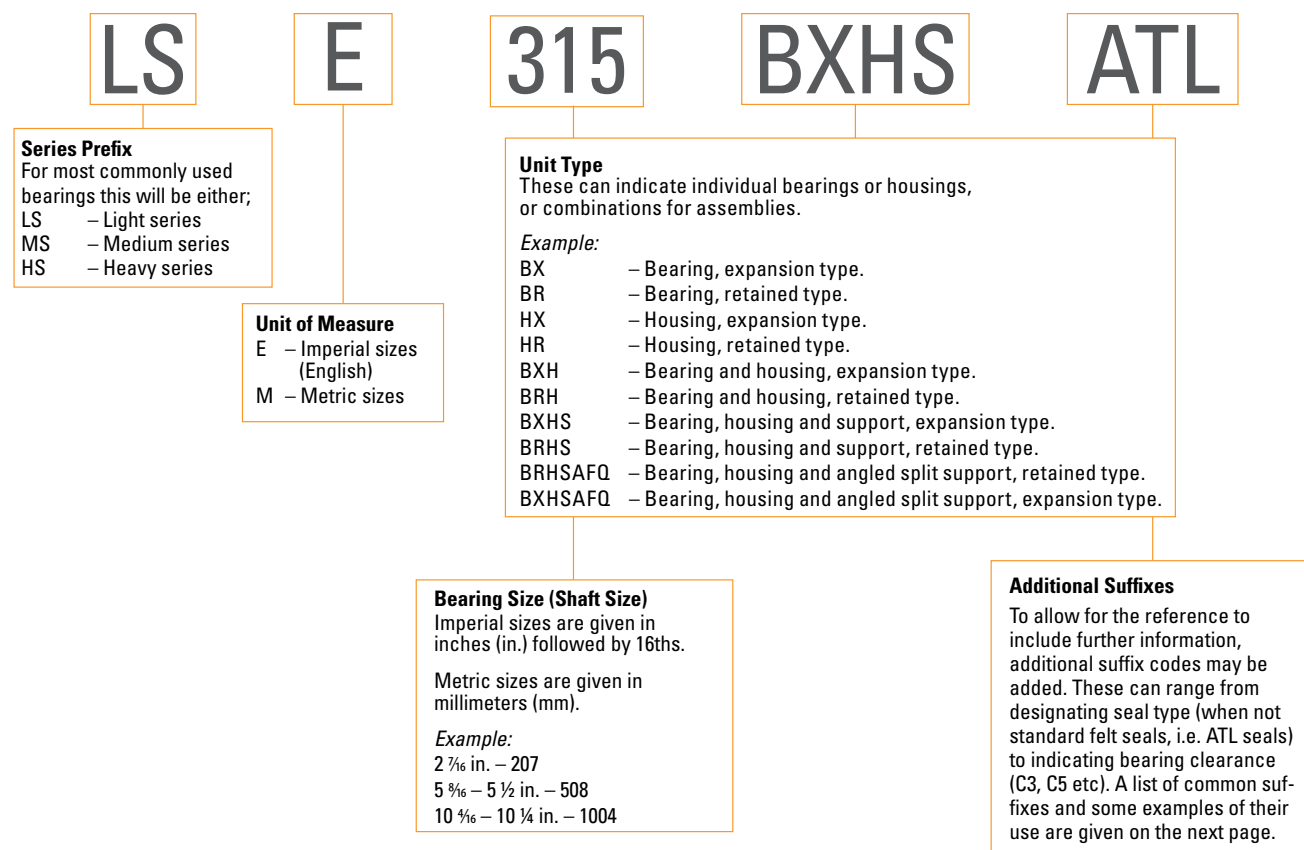

**Fig. 3. Nomenclature.**

For Triple Labyrinth (ATL) style housings and seals see pages 32-34.

### Typical Examples

#### LSE108BXHATL

Light series 1 <sup>1</sup>/<sub>2</sub> in. bearing with housing and ATL seals.

#### LSE407BR

Light series 4 <sup>7</sup>/<sub>16</sub> in. bearing retained.

#### MSE200BXHSATL

Medium series 2 in. expansion bearing with housing and with ATL seals.

#### LSE700BXHSAFQATL

Light series 7 in. bearing, housing and angled split support retained type with ATL seals.

#### MSE815BRHSKPS

Medium series 8 <sup>15</sup>/<sub>16</sub> in. bearing, housing and support, retained type with Kevlar® seals.

#### LSE315BXHSATL

Light series 3 <sup>15</sup>/<sub>16</sub> in. bearing, housing and support, expansion type with ATL seals.

**QUICK REFERENCE TABLES**

**TABLE 3. SERIES PREFIXES**

| Series Prefixes |                                  |
|-----------------|----------------------------------|
| LSE             | Light series imperial            |
| LSM             | Light series metric              |
| MSE             | Medium series imperial           |
| MSM             | Medium series metric             |
| HSE             | Heavy series imperial            |
| HSM             | Heavy series metric              |
| XSE             | Tubular strander series imperial |
| XSM             | Tubular strander series metric   |
| CCE             | Water cooled series imperial     |
| CCM             | Water cooled series metric       |

**TABLE 4. UNIT TYPE REFERENCES**

| Unit Type References |                                                         |
|----------------------|---------------------------------------------------------|
| BX                   | Expansion bearing                                       |
| BR                   | Retained bearing                                        |
| HX                   | Expansion housing                                       |
| HR                   | Retained housing                                        |
| HG                   | Hanger support                                          |
| BXH                  | Expansion bearing with housing                          |
| BRH                  | Retained bearing with housing                           |
| BXHG                 | Expansion bearing with hanger                           |
| BXHS                 | Expansion bearing with housing and support              |
| BRHS                 | Retained bearing with housing and support               |
| BXHF                 | Expansion bearing with housing and flange               |
| BRHF                 | Retained bearing with housing and flange                |
| BXHTT                | Expansion bearing with housing and tension type take up |
| BRHTT                | Retained bearing with housing and tension type take up  |
| BXHTP                | Expansion bearing with housing and pull type take up    |
| BRHTP                | Retained bearing with housing and pull type take up     |

**TABLE 5. ADDITIONAL SUFFIXES**

| Examples of Additional Suffixes |                                                        |
|---------------------------------|--------------------------------------------------------|
| F                               | Axial float                                            |
| AP                              | Air purge                                              |
| ATL                             | Aluminium triple labyrinth                             |
| BEM                             | Base ends machined                                     |
| BL                              | Brass label                                            |
| BOEC                            | Bolt-on end cover                                      |
| C2, C3, C5                      | Bearing clearance (ISO)                                |
| CH                              | Inner race bore chamfer with size e.g. CH6mm, CH11mm   |
| E0302                           | Specifications for marine applications                 |
| EC                              | End cover                                              |
| ECTL                            | End cover for triple labyrinth bore                    |
| ES                              | Electrical specification                               |
| FC                              | Full compliment of rollers                             |
| GE                              | Grease escape                                          |
| HTPS                            | High temperature packing seal                          |
| LSR                             | Laminar seal rings                                     |
| OB                              | Overbored with size e.g. OB160mm                       |
| OTL                             | Overbored triple labyrinth seal                        |
| RSS                             | Nitrile single lip seal                                |
| S1, S2, S3                      | Designation for tempered bearings (ISO)                |
| SF0                             | Swivel fit, zero clearance                             |
| SLO                             | Single lipped outer                                    |
| SLUB                            | Spherical lubrication                                  |
| SNQ                             | SN angled split                                        |
| TE                              | Temperature probe hole                                 |
| WSRP                            | Single lip seal with garter spring and retaining plate |
| XAR                             | Extended antirotation pin                              |



TABLE 6.

| Light Series    |                   |         |        |          |      |
|-----------------|-------------------|---------|--------|----------|------|
| in.             | mm                | Support | Flange | Take Ups |      |
| 1 3/16 to 1 1/2 | <b>35 to 40</b>   | S01     | F01    | TT01     | TP01 |
| 1 1/16 to 2     | <b>45 to 50</b>   | S02     | F02    | TT02     | TP02 |
| 2 3/16 to 2 1/2 | <b>60 to 65</b>   | S03     | F03    | TT03     | TP03 |
| 2 1/16 to 3     | <b>70 to 75</b>   | S04     | F04    | TT04     | TP04 |
| 3 3/16 to 3 1/2 | <b>80 to 90</b>   | S05     | F05    | TT05     | TP05 |
| 3 1/16 to 4     | <b>100 to 105</b> | S06     | F06    | TT06     | TP06 |
| 4 3/16 to 4 1/2 | <b>110 to 115</b> | S07     | F07    | TT07     | TP07 |
| 4 1/16 to 5     | <b>120 to 130</b> | S08     | F08    | TT08     | TP08 |
| 5 3/16 to 5 1/2 | <b>135 to 140</b> | S09     | F09    | TT09     | TP09 |
| 5 1/16 to 6     | <b>150 to 155</b> | S10     | F10    | TT10     | TP10 |
| 6 7/16 to 6 1/2 | <b>160</b>        | S11     | F11    | –        | –    |
| 6 1/16 to 7     | <b>170 to 180</b> | S12     | F12    | –        | –    |
| 7 1/4 to 8      | <b>190 to 200</b> | S13     | F13    | –        | –    |
| 8 1/2 to 9      | <b>220 to 230</b> | S14     | F14    | –        | –    |
| 9 1/2 to 10     | <b>240 to 250</b> | S15     | F15    | –        | –    |
| 10 1/2 to 11    | <b>260 to 280</b> | S16     | F16    | –        | –    |
| 11 1/2 to 12    | <b>300</b>        | S17     | –      | –        | –    |
| 12 1/2 to 13    | <b>320 to 330</b> | S18     | –      | –        | –    |
| 14              | <b>340 to 350</b> | S19     | –      | –        | –    |
| 15              | <b>360 to 380</b> | S20     | –      | –        | –    |
| 16              | <b>400</b>        | S21     | –      | –        | –    |
| 17              | <b>420</b>        | S22     | –      | –        | –    |
| 18              | <b>440 to 460</b> | S23     | –      | –        | –    |
| 19              | <b>480</b>        | S24     | –      | –        | –    |
| 20              | <b>500</b>        | S25     | –      | –        | –    |
| 21              | <b>530</b>        | S26     | –      | –        | –    |
| 22              | <b>560</b>        | S27     | –      | –        | –    |
| 23              | <b>580</b>        | S28     | –      | –        | –    |
| 24              | <b>600</b>        | S29     | –      | –        | –    |

TABLE 7.

| Medium Series   |                   |         |        |          |      |
|-----------------|-------------------|---------|--------|----------|------|
| in.             | mm                | Support | Flange | Take Ups |      |
| –               | –                 | –       | –      | –        | –    |
| 1 1/16 to 2     | <b>45 to 50</b>   | S03     | F03    | TT03     | TP03 |
| 2 3/16 to 2 1/2 | <b>60 to 65</b>   | S04     | F04    | TT04     | TP04 |
| 2 1/16 to 3     | <b>70 to 75</b>   | S05     | F05    | TT05     | TP05 |
| 3 3/16 to 3 1/2 | <b>80 to 90</b>   | S06     | F06    | TT06     | TP06 |
| 3 1/16 to 4     | <b>100 to 105</b> | S07     | F07    | TT07     | TP07 |
| 4 3/16 to 4 1/2 | <b>110 to 115</b> | S08     | F08    | TT08     | TP08 |
| 4 1/16 to 5     | <b>120 to 130</b> | S10     | F10    | TT09     | TP09 |
| 5 3/16 to 5 1/2 | <b>135 to 140</b> | S30     | F30    | TT30     | TP30 |
| 5 1/16 to 6     | <b>150 to 155</b> | S31     | F31    | TT31     | TP31 |
| 6 7/16 to 6 1/2 | <b>160 to 170</b> | S32     | F32    | –        | –    |
| 6 1/16 to 7     | <b>180</b>        | S33     | F33    | –        | –    |
| 7 1/4 to 8      | <b>190 to 200</b> | S34     | F34    | –        | –    |
| 8 1/2 to 9      | <b>220 to 230</b> | S35     | F35    | –        | –    |
| 9 1/2 to 10     | <b>240 to 260</b> | S36     | F36    | –        | –    |
| 10 1/2 to 11    | <b>280</b>        | S37     | F37    | –        | –    |
| 11 1/2 to 12    | <b>300</b>        | S38     | F38    | –        | –    |
| 12 1/2 to 13    | <b>320 to 330</b> | S39     | –      | –        | –    |
| 14              | <b>340 to 360</b> | S40     | –      | –        | –    |
| 15              | <b>380</b>        | S41     | –      | –        | –    |
| 16              | <b>400</b>        | S42     | –      | –        | –    |
| 17              | <b>420</b>        | S43     | –      | –        | –    |
| 18              | <b>440 to 460</b> | S44     | –      | –        | –    |
| 19              | <b>480</b>        | S45     | –      | –        | –    |
| 20              | <b>500</b>        | S46     | –      | –        | –    |
| 21              | <b>530</b>        | S47     | –      | –        | –    |
| 22              | <b>560</b>        | S48     | –      | –        | –    |
| 23              | <b>580</b>        | S49     | –      | –        | –    |
| 24              | <b>600</b>        | S50     | –      | –        | –    |

TABLE 8.

| Heavy Series    |                   |         |        |
|-----------------|-------------------|---------|--------|
| in.             | mm                | Support | Flange |
| –               | –                 | –       | –      |
| –               | –                 | –       | –      |
| –               | –                 | –       | –      |
| –               | –                 | –       | –      |
| –               | –                 | –       | –      |
| 3 1/16 to 4     | <b>100 to 105</b> | S54     | F54    |
| 4 3/16 to 4 1/2 | <b>110 to 120</b> | S55     | F55    |
| 4 1/16 to 5     | <b>125 to 130</b> | S56     | F56    |
| 5 3/16 to 5 1/2 | <b>135 to 140</b> | S57     | F57    |
| 5 1/16 to 6     | <b>150 to 155</b> | S58     | F58    |
| 6 7/16 to 6 1/2 | <b>160 to 170</b> | S59     | F59    |
| 6 1/16 to 7     | <b>180</b>        | S60     | F60    |
| 7 1/4 to 8      | <b>190 to 200</b> | S61     | F61    |
| 8 1/2 to 9      | <b>220 to 230</b> | S62     | F62    |
| 9 1/2 to 10     | <b>240 to 260</b> | S63     | F63    |
| 11              | <b>280</b>        | S83     | F64    |
| 12              | <b>300</b>        | S65     | F65    |
| 13              | <b>320 to 330</b> | S66     | –      |
| 14              | <b>340 to 360</b> | S86     | –      |
| 15 to 16        | <b>380 to 400</b> | S68     | –      |
| –               | –                 | –       | –      |
| 17              | <b>420 to 440</b> | S89     | –      |
| 18              | <b>460</b>        | S90     | –      |
| 19              | <b>480</b>        | S94     | –      |
| 20              | <b>500</b>        | S94     | –      |
| 21              | <b>530</b>        | S94     | –      |
| 22              | <b>560</b>        | S94     | –      |
| 23              | <b>580</b>        | S95     | –      |
| 24              | <b>600</b>        | S95     | –      |

## BEARING TYPES

### RETAINED-TYPE BEARINGS (BR)

This bearing has integral flanges on the outer race to provide a surface for axial load. This axial load is accommodated on the inner race via the hardened clamp rings, which both align the inner race halves and provide roller guidance. In larger bearings the inner race is manufactured with integral ribs for roller guidance and axial load.

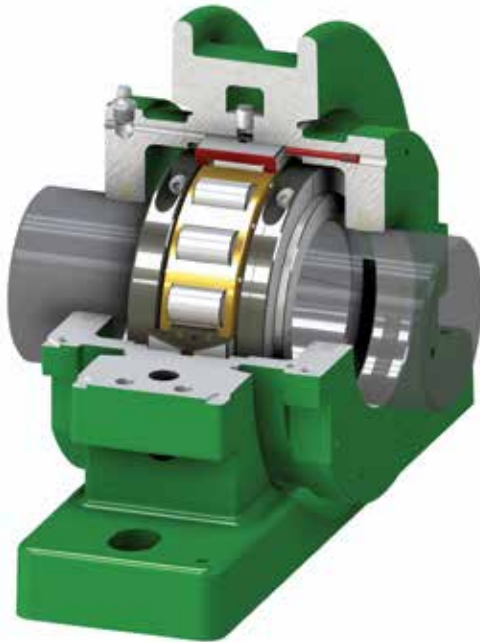

**Fig. 4. Retained-type bearings (BR).**

This type of bearing will locate the shaft axially as well as provide a means for taking axial load. The retained outer race must be fixed sideways against one of the housing groove shoulders using the pins and screws provided. Only one retained unit should be mounted on any particular shaft. Additional care should be taken when mounting split cylindrical roller bearing unit on shafts using other, non-split types of bearings (ball, cylindrical and spherical roller, etc.) to ensure there are no other locating bearings used.

### EXPANSION-TYPE BEARINGS (BX)

This bearing is designed for radial loads only. As in the retained type bearing, the rollers are guided on the inner race by the hardened shoulders of the clamping rings.



**Fig. 5. Expansion-type bearings (BX).**

During expansion or contraction of the shaft, rollers are free to move across the outer race offering virtually no resistance to axial movement. Limits for the amount of axial movement are given in the assembly and maintenance section (pages 36-39).

## SUPPORT TYPES

Timken bearings and housings may be mounted in a variety of support units according to the application and loading constraints. A number of variants are available as standard types with other unit types available on request. Timken offers a design and manufacturing facility to produce custom units to cover more specialized applications.

### PILLOW BLOCK (SUPPORT) TYPE

This is by far the most popular method for mounting Timken units. These supports are manufactured from high strength, ASTM 48A grade 35 cast iron. This, combined with the robust design, provides a stable, rigid base, allowing the split bearing fitted to give optimum performance.

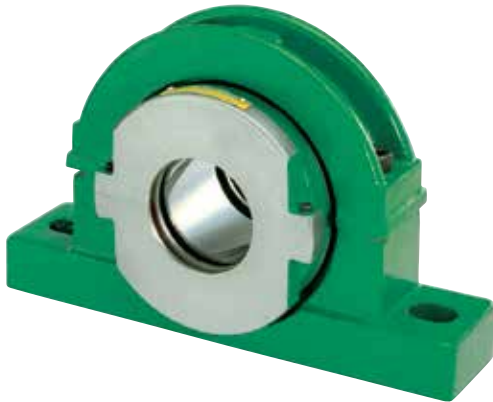

Fig. 6. Pillow block support type.

### FLANGE UNITS

In applications where bearings need to be mounted against horizontal or vertical faces, Timken flange units provide a simple means of achieving this goal. Again, the use of ASTM 48A Grade 35 cast iron ensures a durable unit.



Fig. 7. Flange units.

### HANGER UNITS

A compact unit commonly used for supporting screw conveyors or similar equipment.



Fig. 8. Hanger units.

### TAKE-UP UNITS

These sliding units can be used to effectively tension conveyor and elevator systems. Both pull and push types are available.



Fig. 9. Take-up units.

## SERIES COMPARISON

Timken offers a range of bearing series, providing solutions for a wide range of operating conditions. Light Series, Medium Series and Heavy Series offer an increasing ability to accommodate higher loads. As the series increases the speed capability reduces.

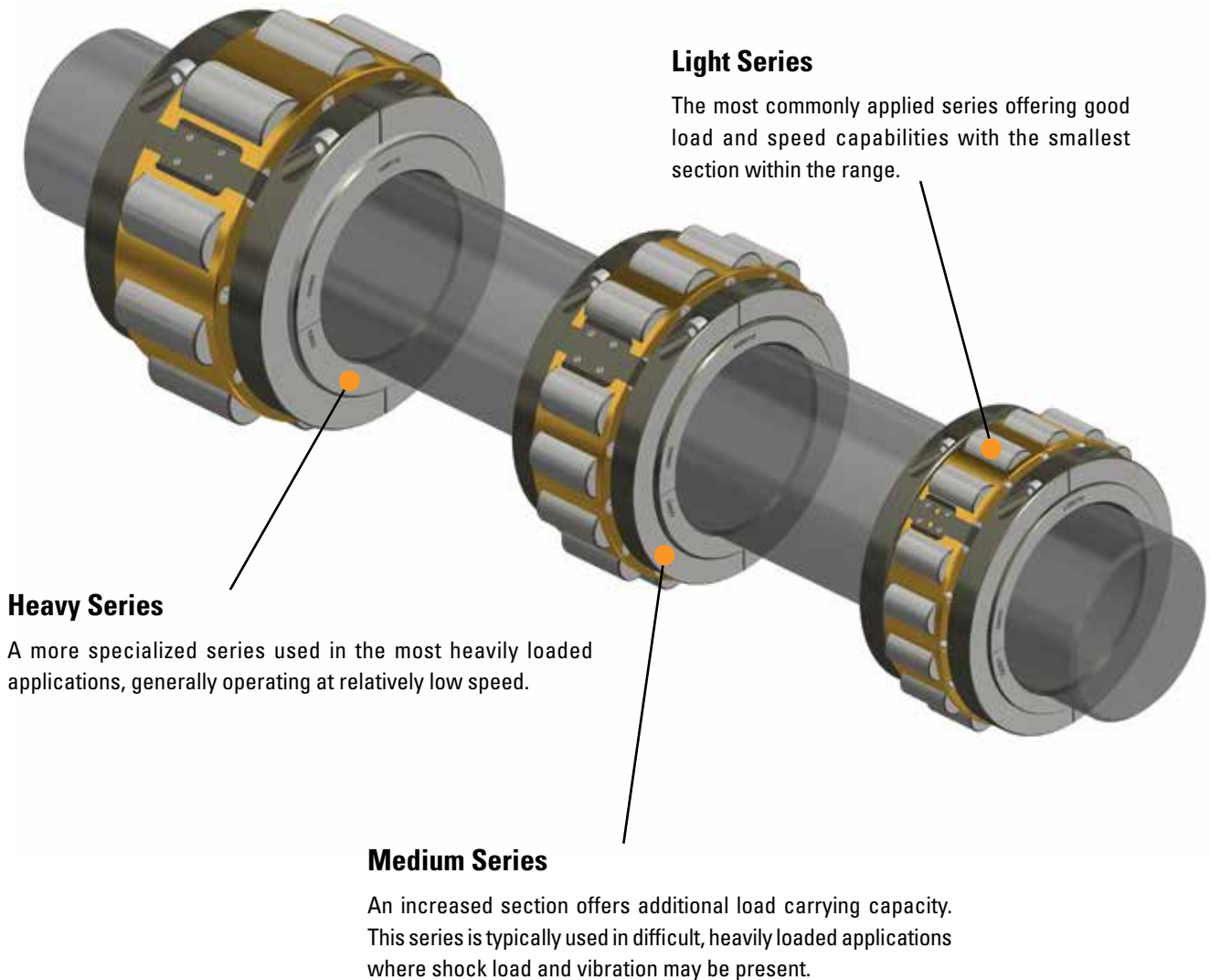

Fig. 10. Series comparison.

## BEARING SELECTION

### DYNAMIC LOADING

Selection of Timken split cylindrical roller bearings must take into account the effects of both radial and axial loads. These loads must be considered independently of each other.

### RADIAL LOAD CONSIDERATIONS

The basic rating life of a bearing can be derived from the formula laid down in ISO 281:2007.

$$L_{10} = (C/P)^{10/3} \text{ (Millions of Revolutions)} \quad - (i)$$

In the majority of cases where the speed remains constant then the life can be expressed in hours from the formula.

$$L_{10}h = \frac{(10^6) \times L_{10}}{60 \times n} \quad - (ii)$$

Substituting – (i)

$$L_{10}h = \frac{(10^6) \times \left( \frac{C}{P} \right)^{10/3}}{60 \times n} \quad - (ii)$$

$L_{10}$  = Basic rating life (90 percent reliability),  
10<sup>6</sup> revolutions

$L_{10}h$  = Basic rating life (90 percent reliability), hours

$C$  = Bearing dynamic capacity, kN

$N$  = Speed, min<sup>-1</sup>

$P$  = Equivalent bearing load

This calculation assumes for the load components considered for an individual bearing, that the shaft system is a beam resting on rigid, movement free supports. Elastic deformations in the bearing, housing or machine structure are not taken into account.

### EQUIVALENT LOAD “P”

As previously stated radial and axial loads must be considered separately for split cylindrical roller bearings. For the calculation of theoretical life only radial loads are considered.

### $F_r$ = RADIAL LOADS

The value of  $F_r$  is that calculated from standard mechanical formula, the impact of additional forces resulting from external influences must also be considered.

TABLE 9.

| Load Condition                | Factor $F_z$ |
|-------------------------------|--------------|
| Steady                        | 1.0 to 1.3   |
| Light shock or out of balance | 1.3 to 2.0   |
| Heavy shock or vibration      | 2.0 to 3.0   |

### $F_z$ = FACTOR

Under the influence of the above conditions.

### $P = F_r \times F_z$

The required theoretical bearing life is based upon a number of factors, including reliability, accessibility and service considerations. Generally life values should be as follows:

TABLE 10.

| Guide to Life Values        |                         |
|-----------------------------|-------------------------|
| Machine used intermittently | 500 to 2,000 hours      |
| Occasional use              | 5,000 to 10,000 hours   |
| Normal operation            | 20,000 to 50,000 hours  |
| Continuous operation        | 75,000 to 100,000 hours |
| High reliability            | > 100,000               |

## ADJUSTED LIFE CALCULATION

The  $L_{10}$  fatigue life calculation is based upon the rating life of a large number of identical bearings expressed as a number of revolutions operating at a constant speed. This rating life is reached or exceeded by 90 percent of these before the first evidence of fatigue appears.

The above definition applies to bearings operating under optimum conditions. Variations in operating conditions will lead to changes in the life of these bearings.

ISO 281 allows for an adjusted life calculation:

$$L_{hna} = a_1 \times a_2 \times a_3 \times L_{10}h$$

Where

$L_{hna}$  = Adjusted life

$L_{10}h$  = Rating life in hours

$a_1$  = Life adjustment factor, failure probability other than 10 percent

$a_2$  = Life adjustment factor, material properties

$a_3$  = Life adjustment factor, operating conditions

### $a_1$ FACTOR

In cases where a failure rate other than 10 percent is required, then an  $a_1$  factor as in the table below should be applied.

TABLE 11.

| Adjustment Factor     |      |      |      |      |      |      |
|-----------------------|------|------|------|------|------|------|
| Failure Probability % | 10   | 5    | 4    | 3    | 2    | 1    |
| Factor $a_1$          | 1.00 | 0.62 | 0.53 | 0.44 | 0.33 | 0.21 |

### $a_2$ FACTOR

This factor takes into account the material properties.

### $a_3$ FACTOR

The  $a_3$  factor considers all operational parameters that influence fatigue life. The most obvious of these is lubrication. The highest life values are achieved where a state of hydrodynamic lubrication exists, in this state no metal-to-metal contact occurs.

Decreasing effectiveness of lubricant due to decreasing film thickness or effects of contamination will reduce the  $a_3$  factor.

Due to the interrelationships between materials adjustment factor  $a_2$  and operating adjustment factor  $a_3$ , a common factor  $a_{23}$  is frequently used.

### $a_{23}$ FACTOR

$$a_{23} = a_2 \times a_3$$

The  $a_{23}$  factor can be taken from Fig. 11.

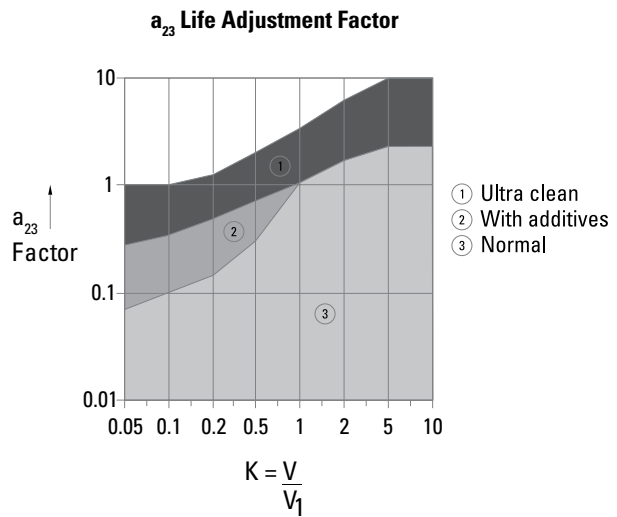

$V_1$  = Rated viscosity (depends on bearing size and operating speed)

$V$  = Operating viscosity (depends on original viscosity and operating temperature)

Fig. 11. Life adjustment factor.

Values for  $V$  and  $V_1$  are obtained from the following graphs:

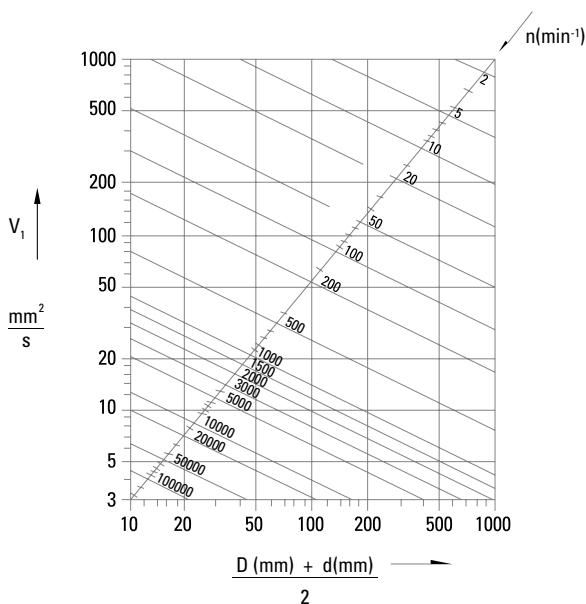

Fig. 12.  $V$  and  $V_1$  values.

Where

- $D$  = Bearing outside diameter
- $d$  = Bearing bore
- $n$  = Shaft speed (RPM)

$V_1$  is then read off the vertical axis.

Using the operating temperature and nominal lubricant viscosity, the value for operating viscosity,  $V$ , is read from the horizontal axis.

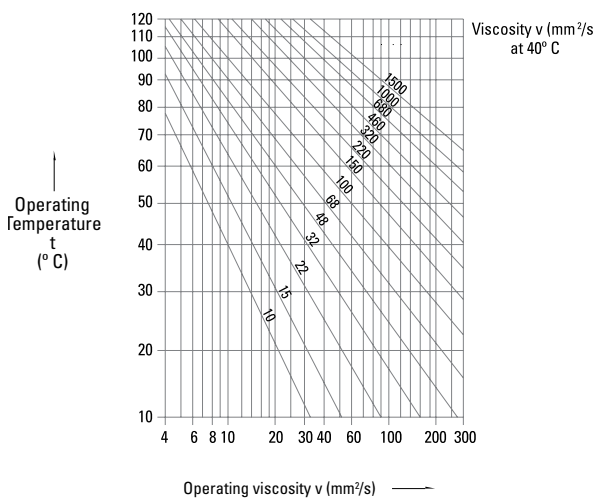

Fig. 13. Operating viscosity.

## STATIC LOADING

In situations where bearings rotate slowly (<10 RPM), oscillate slowly, are stationary for prolonged periods or subject to high shock loads, it is important to check that no permanent deformations occur between rolling elements and raceways at peak load.

The basic static load rating is defined in ISO 76:1987 and refers to the contact stress at the centre of the most heavily loaded rolling element/raceway contact area. For roller bearings this value is 4000 Mpa. This will result in a permanent deformation of 0.0001 of the roller diameter.

The required static load rating can be determined from:

$$C_o = F_s \times P_o$$

$C_o$  = Basic static load rating

$P_o$  = Equivalent static load

$F_s$  = Static safety factor

Guidelines for the static safety factor  $F_s$  can be found in the table below:

TABLE 12.

| Nature of Duty       | Requirements for Duty |        |      |
|----------------------|-----------------------|--------|------|
|                      | Low                   | Medium | High |
| Smooth, no vibration | 1.0                   | 1.5    | 3.0  |
| Normal               | 1.0                   | 1.5    | 3.5  |
| Heavy                | >2.5                  | >3.0   | >4.0 |

# BEARING RATINGS

TABLE 13. LIGHT SERIES

| Shaft (d) |         | Bearing Ratings        |                        |                      |      |
|-----------|---------|------------------------|------------------------|----------------------|------|
|           |         | Dynamic C <sub>r</sub> | Static C <sub>or</sub> | Axial C <sub>a</sub> | Max  |
| mm        | in.     | kN lb.                 | kN lb.                 | kN lb.               | RPM  |
| 35        | 1 3/16  | 65                     | 68                     | 3.20                 | 5400 |
| 40        | 1 1/2   | 14613                  | 15287                  | 719.38               |      |
| 45        | 1 11/16 | 83                     | 87                     | 3.60                 | 4630 |
| 50        | 2       | 18659                  | 19558                  | 809.30               |      |
| 55        | 2 3/16  | 103                    | 115                    | 5.40                 | 3940 |
| 65        | 2 1/2   | 23155                  | 25853                  | 1213.95              |      |
| 70        | 2 11/16 | 138                    | 161                    | 7.60                 | 3310 |
| 75        | 3       | 31024                  | 36194                  | 1708.53              |      |
| 80        | 3 3/16  | 187                    | 231                    | 12.40                | 2790 |
| 90        | 3 1/2   | 42039                  | 51931                  | 2787.59              |      |
| 100       | 3 11/16 | 288                    | 366                    | 16.00                | 2340 |
| 105       | 4       | 64745                  | 82280                  | 3596.90              |      |
| 110       | 4 3/16  | 316                    | 427                    | 18.60                | 1970 |
| 115       | 4 1/2   | 71040                  | 95993                  | 4181.39              |      |
| 120       | 4 11/16 | 363                    | 496                    | 22.20                | 1740 |
| 130       | 5       | 81606                  | 111505                 | 4990.69              |      |
| 135       | 5 3/16  | 422                    | 585                    | 25.80                | 1570 |
| 140       | 5 1/2   | 94869                  | 131513                 | 5799.99              |      |
| 150       | 5 11/16 | 459                    | 664                    | 29.40                | 1450 |
| 155       | 6       | 103187                 | 149273                 | 6609.30              |      |
| 160       | 6 3/16  | 538                    | 792                    | 33.00                | 1320 |
|           | 6 1/2   | 120947                 | 178049                 | 7419                 |      |
| 170       | 6 11/16 | 524                    | 828                    | 36.40                | 1220 |
| 180       | 7       | 117800                 | 186142                 | 8183                 |      |
| 190       | 7 1/4   | 614                    | 990                    | 41.00                | 1070 |
| 200       | 8       | 138033                 | 222561                 | 9217                 |      |
| 220       | 8 1/2   | 708                    | 1168                   | 49.00                | 930  |
| 230       | 9       | 159165                 | 262577                 | 11016                |      |
| 240       | 9 1/2   | 744                    | 1289                   | 57.80                | 820  |
| 250       | 10      | 167258                 | 289779                 | 12994                |      |
| 260       | 10 1/2  | 848                    | 1502                   | 66.80                | 730  |
| 280       | 11      | 190638                 | 337663                 | 15017                |      |
| 300       | 11 1/2  | 929                    | 1665                   | 78.20                | 650  |
| 305       | 12      | 208848                 | 374307                 | 17580                |      |
| 320       | 12 1/2  | 920                    | 1674                   | 89.00                | 590  |
| 330       | 13      | 206824                 | 376330                 | 20008                |      |
| 340       | 14      | 1022                   | 1965                   | 99.60                | 540  |
| 350       |         | 229755                 | 441745                 | 22391                |      |
| 360       | 15      | 1224                   | 2431                   | 110.40               | 500  |
| 380       |         | 275166                 | 546511                 | 24819                |      |
| 400       | 16      | 1107                   | 2266                   | 115.60               | 460  |
|           |         | 248864                 | 509417                 | 25988                |      |
| 420       | 17      | 1146                   | 2418                   | 121.00               | 430  |
|           |         | 257631                 | 543588                 | 27202                |      |
| 440       | 18      | 1185                   | 2469                   | 127.20               | 410  |
| 460       |         | 266399                 | 555053                 | 28596                |      |
| 480       | 19      | 1348                   | 2965                   | 132.60               | 380  |
|           |         | 303042                 | 666559                 | 29810                |      |
| 500       | 20      | 1392                   | 3139                   | 137.80               | 360  |
|           |         | 312934                 | 705675                 | 30979                |      |
| 530       | 21      | 1431                   | 3316                   | 140.60               | 340  |
|           |         | 321702                 | 745466                 | 31608                |      |
| 560       | 22      | 1472                   | 3490                   | 142.40               | 330  |
|           |         | 330919                 | 784583                 | 32013                |      |
| 580       | 23      | 1616                   | 3841                   | 144.00               | 310  |
|           |         | 363291                 | 863491                 | 32372                |      |
| 600       | 24      | 1660                   | 4033                   | 146.80               | 300  |
|           |         | 373183                 | 906654                 | 33002                |      |

TABLE 14. MEDIUM SERIES

| Shaft (d) |         | Bearing Ratings        |                        |                      |      |
|-----------|---------|------------------------|------------------------|----------------------|------|
|           |         | Dynamic C <sub>r</sub> | Static C <sub>or</sub> | Axial C <sub>a</sub> | Max  |
| mm        | in.     | kN lb.                 | kN lb.                 | kN lb.               | RPM  |
| -         | -       | -                      | -                      | -                    | -    |
| 45        | 1 11/16 | 121                    | 127                    | 6.20                 | 4350 |
| 50        | 2       | 27202                  | 28551                  | 1394                 |      |
| 55        | 2 3/16  | 168                    | 190                    | 8.80                 | 3680 |
| 65        | 2 1/2   | 37768                  | 42714                  | 1978                 |      |
| 70        | 2 11/16 | 258                    | 300                    | 10.60                | 3080 |
| 75        | 3       | 58001                  | 67443                  | 2383                 |      |
| 80        | 3 3/16  | 297                    | 353                    | 17.80                | 2520 |
| 90        | 3 1/2   | 66768                  | 79358                  | 4002                 |      |
| 100       | 3 11/16 | 388                    | 491                    | 25.00                | 2130 |
| 105       | 4       | 87226                  | 110381                 | 5620                 |      |
| 110       | 4 3/16  | 454                    | 592                    | 31.20                | 1820 |
| 115       | 4 1/2   | 102063                 | 133087                 | 7014                 |      |
| 120       | 4 11/16 | 525                    | 700                    | 38.20                | 1600 |
| 130       | 5       | 102063                 | 133087                 | 7014                 |      |
| 135       | 5 3/16  | 600                    | 817                    | 45.40                | 1450 |
| 140       | 5 1/2   | 134885                 | 183669                 | 10206                |      |
| 150       | 5 11/16 | 730                    | 1034                   | 52.40                | 1320 |
| 155       | 6       | 164111                 | 232453                 | 11780                |      |
| 160       | 6 3/16  | 842                    | 1175                   | 61.40                | 1200 |
| 170       | 6 1/2   | 189289                 | 264151                 | 13803                |      |
| 180       | 6 11/16 | 927                    | 1357                   | 71.20                | 1120 |
|           | 7       | 208398                 | 305066                 | 16006                |      |
| 190       | 7 1/4   | 1013                   | 1516                   | 80.00                | 960  |
| 200       | 8       | 227732                 | 340810                 | 17985                |      |
| 220       | 8 1/2   | 1138                   | 1668                   | 89.80                | 850  |
| 230       | 9       | 255833                 | 374981                 | 20188                |      |
| 240       | 9 1/2   | 1354                   | 2117                   | 98.80                | 750  |
| 260       | 10      | 304391                 | 475921                 | 22211                |      |
| 270       | 10 1/2  | 1476                   | 2357                   | 113.80               | 670  |
| 280       | 11      | 331818                 | 529875                 | 25583                |      |
| 300       | 11 1/2  | 1587                   | 2644                   | 129.00               | 610  |
| 305       | 12      | 356772                 | 594395                 | 29000                |      |
| 320       | 12 1/2  | 1723                   | 2922                   | 144.20               | 550  |
| 330       | 13      | 387346                 | 656892                 | 32417                |      |
| 340       | 14      | 2029                   | 3403                   | 159.20               | 500  |
| 360       |         | 456137                 | 765025                 | 35790                |      |
| 380       | 15      | 1931                   | 3522                   | 174.40               | 460  |
|           |         | 434106                 | 791777                 | 39207                |      |
| 400       | 16      | 2105                   | 3793                   | 188.40               | 430  |
|           |         | 473223                 | 852701                 | 42354                |      |
| 420       | 17      | 2324                   | 4164                   | 202.00               | 400  |
|           |         | 522456                 | 936105                 | 45411                |      |
| 440       | 18      | 2215                   | 4183                   | 216.00               | 380  |
| 460       |         | 497952                 | 940376                 | 48559                |      |
| 480       | 19      | 2445                   | 4594                   | 230.00               | 360  |
|           |         | 549658                 | 1032773                | 51706                |      |
| 500       | 20      | 2453                   | 4923                   | 244.00               | 340  |
|           |         | 551456                 | 1106734                | 54853                |      |
| 530       | 21      | 2702                   | 5415                   | 258.00               | 330  |
|           |         | 607434                 | 1217340                | 58001                |      |
| 560       | 22      | 2851                   | 5740                   | 272.00               | 310  |
|           |         | 640930                 | 1290403                | 61148                |      |
| 580       | 23      | 2982                   | 6173                   | 286.00               | 300  |
|           |         | 670380                 | 1387746                | 64295                |      |
| 600       | 24      | 2972                   | 6185                   | 300.00               | 290  |
|           |         | 668132                 | 1390443                | 67443                |      |

Axial load ratings (C<sub>a</sub>) assume the use of EP additives or oil lubrication, otherwise use 50 percent of values. Higher loads and speeds may be permissible. Please contact a Timken engineer for more information.





## AXIAL CONSIDERATIONS

### AXIAL LOAD

Bearing selection, on an axial load basis, must be considered independently from the radial load.

1. Calculate the axial loads acting on the bearing.
2. Multiply each load by the appropriate dynamic factor  $f_z$ .
3. Combine these loads to determine the effective axial load  $P_a$ .
4. Select a bearing having a  $C_a$  value greater than the product of  $P_a \times f_{dn}$ ,  $d \cdot n$  is the product of the shaft size in millimeter and the speed in RPM. To determine  $f_{dn}$  use the velocity graph below.

### AXIAL RATINGS $C_a$

These ratings are for constant loads with oil or extra pressure greases. If greases without extra pressure additives are applied then the catalog rating must be decreased by 50 percent. In instances where bearings operate at over 50 percent of their catalog speed rating and over 50 percent of their axial load ratings ( $C_a$ ) then recessed shafts should be considered. Please contact a Timken engineer for assistance.

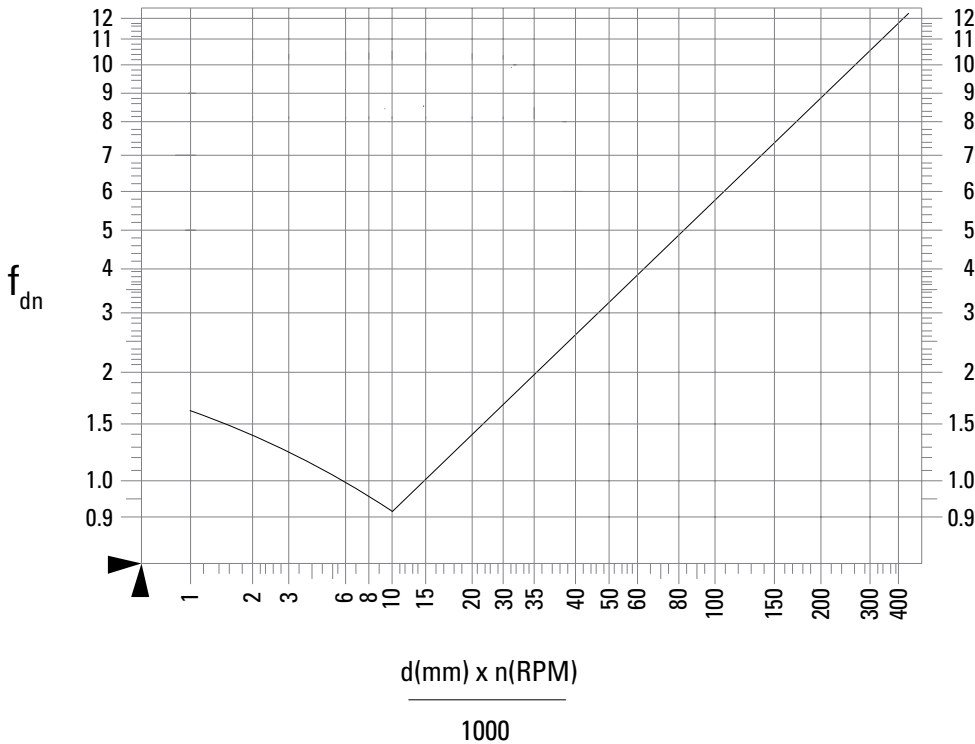

**VELOCITY**

Applies only to axial loads on br retained bearings.

Bearing bore =  $d$

Bearing RPM =  $n$

**Fig. 14. Velocity graph.**

## BEARING CLEARANCE AND TEMPERATURE CONSIDERATIONS

Timken bearings are manufactured to give an ISO CN clearance as standard. At specific customer request, bearings may be produced with any clearance to suit a particular application. When assessing the requirement for special clearances, it is particularly important to consider the differential temperature between shaft and housing. It also should be noted that an increase in bearing clearance will lead to a small reduction in bearing capacity. For example, typically a C<sub>3</sub> clearance will reduce capacity by 5 percent and C<sub>5</sub> clearance by 10 percent.

Timken bearings also can be produced as C<sub>2</sub>. This clearance is smaller than CN and is typically used in applications involving shock or reciprocating loads.

Cleanliness of component parts when fitting will have a direct impact on the running clearance of the bearing. This is of particular importance when fitting new bearings into existing cast iron or refitting bearings after maintenance. Special care must be taken to remove build-ups of aged grease and other contaminants in order to avoid reducing the bearing clearance when fitted.

When selecting bearings for use at elevated temperatures, consideration also should be given to the bearings' dimensional stability. Timken bearings are tempered to give stability up to 140° C (284° F). In order to operate at higher temperatures, bearings must be specially heat-treated. This process will lead to a reduction in capacity as a result of the reduced hardness.

The designations for specially heat-treated bearings are in line with those quoted in ISO standards. The effects of temperature stabilization are detailed in the table shown.

TABLE 16.

| Operating Temperature | 200° C | 250° C | 300° C |
|-----------------------|--------|--------|--------|
|                       | 392° F | 482° F | 572° F |
| Designation           | S1     | S2     | S3     |
| Reduction in Capacity | 10%    | 25%    | 40%    |

## SUPPORT LOADS AND BEARING FREQUENCIES

Throughout the Timken range, the split cylindrical roller bearing supports have been designed to provide a rigid and stable base to enable the associated bearing to operate to its full potential. With this in mind, all types of Timken split cylindrical roller bearing housings and supports are manufactured from ASTM 48A – Grade 35 cast iron as a minimum and include strengthening webs and ribs to provide a highly robust unit. In order to complement the inherent strength, we recommend that careful consideration be given to the siting and mounting of the support unit.

To determine a support's suitability, one should consider the resultant effective load derived in the bearing selection process and the direction of that load. The diagram shown indicates the area in which the full C<sub>0r</sub> rating of the bearing may be applied. Should the direction of the applied load be outside this area it may be necessary to consider alternative designs or materials. Timken has a proven track record of innovative solutions and would be happy to provide assistance.

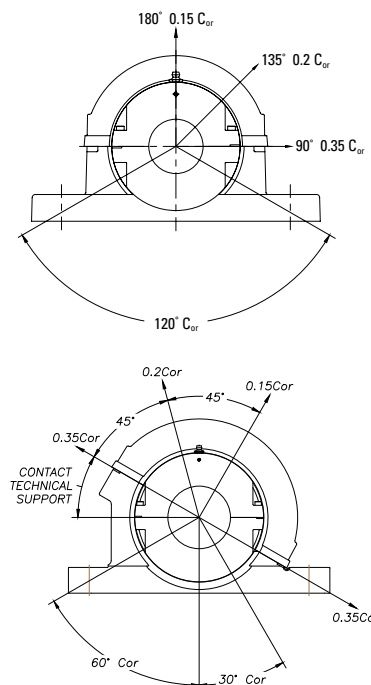

Fig. 15. C<sub>0r</sub> rating application.

Condition monitoring is the collection, storage, comparison and evaluation of data taken to establish the running condition of a machine. The data can be made up of several parameters, for example, electric current, pressure, brush wear, vibration and temperature, to name a few. Vibration analysis is the area of condition monitoring concerned with evaluating and identifying the source of vibration within a system and assessing its severity and hence proposing the required maintenance action.

The individual components of any bearing will exhibit frequency characteristics which will identify it within a system subject to vibration analysis. For Timken bearings these characteristic frequencies are detailed in the tables opposite. The values given are for a nominal speed of 1 RPM. To obtain the correct frequency required for vibration analysis software, multiply by the speed of rotation in RPM.

For further information on condition monitoring services Please contact a Timken engineer.

**BEARING FREQUENCY TABLES (HZ)**

**TABLE 17. LIGHT SERIES**

|     |         | Inner Race | Outer Race | Roller | Cage  |
|-----|---------|------------|------------|--------|-------|
| mm  | in.     | hz         | hz         | hz     | hz    |
| 35  | 1 3/16  |            |            |        |       |
| 40  | 1 1/2   | 5.878      | 4.122      | 2.760  | 0.412 |
| 45  | 1 11/16 |            |            |        |       |
| 50  | 2       | 5.852      | 4.148      | 2.847  | 0.415 |
| 60  | 2 3/16  |            |            |        |       |
| 65  | 2 1/2   | 6.932      | 5.068      | 3.140  | 0.422 |
| 70  | 2 11/16 |            |            |        |       |
| 75  | 3       | 6.902      | 5.098      | 3.252  | 0.425 |
| 80  | 3 3/16  |            |            |        |       |
| 90  | 3 1/2   | 8.017      | 5.983      | 3.370  | 0.427 |
| 100 | 3 11/16 |            |            |        |       |
| 105 | 4       | 8.089      | 5.911      | 3.137  | 0.422 |
| 110 | 4 3/16  |            |            |        |       |
| 115 | 4 1/2   | 9.109      | 6.891      | 3.538  | 0.431 |
| 120 | 4 11/16 |            |            |        |       |
| 130 | 5       | 9.100      | 6.900      | 3.569  | 0.431 |
| 135 | 5 3/16  |            |            |        |       |
| 140 | 5 1/2   | 9.087      | 6.913      | 3.612  | 0.432 |
| 150 | 5 11/16 |            |            |        |       |
| 155 | 6       | 10.159     | 7.841      | 3.819  | 0.436 |
| 160 | 6 7/16  |            |            |        |       |
| 160 | 6 1/2   | 10.162     | 7.838      | 3.809  | 0.435 |
| 170 | 6 11/16 |            |            |        |       |
| 180 | 7       | 12.223     | 9.777      | 4.442  | 0.444 |
| 190 | 7 1/4   |            |            |        |       |
| 200 | 8       | 12.204     | 9.796      | 4.515  | 0.445 |
| 220 | 8 1/2   |            |            |        |       |
| 230 | 9       | 12.171     | 9.829      | 4.645  | 0.447 |
| 240 | 9 1/2   |            |            |        |       |
| 250 | 10      | 13.154     | 10.846     | 5.152  | 0.452 |
| 260 | 10 1/2  |            |            |        |       |
| 280 | 11      | 13.118     | 10.882     | 5.319  | 0.453 |
| 300 | 11 1/2  |            |            |        |       |
| 305 | 12      | 13.087     | 10.913     | 5.472  | 0.455 |
| 320 | 12 1/2  |            |            |        |       |
| 330 | 13      | 13.028     | 10.972     | 5.795  | 0.457 |
| 340 |         |            |            |        |       |
| 350 | 14      | 15.125     | 12.875     | 6.182  | 0.460 |
| 360 |         |            |            |        |       |
| 380 | 15      | 16.133     | 13.867     | 6.580  | 0.462 |
| 400 | 16      | 17.150     | 14.850     | 6.92   | 0.464 |
| 420 | 17      | 18.156     | 15.844     | 7.319  | 0.466 |
| 440 |         |            |            |        |       |
| 460 | 18      | 19.165     | 16.835     | 7.694  | 0.468 |
| 480 | 19      | 19.166     | 16.834     | 7.684  | 0.468 |
| 500 | 20      | 20.177     | 17.823     | 8.038  | 0.469 |
| 530 | 21      | 21.175     | 18.825     | 8.479  | 0.471 |
| 560 | 22      | 22.184     | 19.816     | 8.841  | 0.472 |
| 580 | 23      | 23.254     | 20.746     | 8.744  | 0.472 |
| 600 | 24      | 23.208     | 20.792     | 9.078  | 0.473 |

**TABLE 18. MEDIUM SERIES**

|     |         | Inner Race | Outer Race | Roller | Cage  |
|-----|---------|------------|------------|--------|-------|
| mm  | in.     | hz         | hz         | hz     | hz    |
| -   | -       | -          | -          | -      | -     |
| 45  | 1 11/16 |            |            |        |       |
| 50  | 2       | 5.988      | 4.012      | 2.432  | 0.401 |
| 60  | 2 3/16  |            |            |        |       |
| 65  | 2 1/2   | 7.091      | 4.909      | 2.659  | 0.409 |
| 70  | 2 11/16 |            |            |        |       |
| 75  | 3       | 7.153      | 4.847      | 2.506  | 0.404 |
| 80  | 3 3/16  |            |            |        |       |
| 90  | 3 1/2   | 7.091      | 4.909      | 2.659  | 0.409 |
| 100 | 3 11/16 |            |            |        |       |
| 105 | 4       | 8.205      | 5.795      | 2.818  | 0.414 |
| 110 | 4 3/16  |            |            |        |       |
| 115 | 4 1/2   | 8.143      | 5.857      | 2.981  | 0.418 |
| 120 | 4 11/16 |            |            |        |       |
| 130 | 5       | 8.105      | 5.895      | 3.088  | 0.421 |
| 135 | 5 3/16  |            |            |        |       |
| 140 | 5 1/2   | 8.082      | 5.918      | 3.157  | 0.423 |
| 150 | 5 11/16 |            |            |        |       |
| 155 | 6       | 9.225      | 6.775      | 3.188  | 0.423 |
| 160 | 6 7/16  |            |            |        |       |
| 170 | 6 1/2   | 8.107      | 5.893      | 3.083  | 0.421 |
| 180 | 6 11/16 |            |            |        |       |
| 180 | 7       | 9.192      | 6.808      | 3.281  | 0.425 |
| 190 | 7 1/4   |            |            |        |       |
| 200 | 8       | 9.119      | 6.881      | 3.505  | 0.430 |
| 220 | 8 1/2   |            |            |        |       |
| 230 | 9       | 9.161      | 6.839      | 3.372  | 0.427 |
| 240 | 9 1/2   |            |            |        |       |
| 260 | 10      | 10.218     | 7.782      | 3.628  | 0.432 |
| 270 | 10 1/2  |            |            |        |       |
| 280 | 11      | 10.162     | 7.838      | 3.808  | 0.435 |
| 300 | 11 1/2  |            |            |        |       |
| 305 | 12      | 11.207     | 8.793      | 4.082  | 0.440 |
| 320 | 12 1/2  |            |            |        |       |
| 330 | 13      | 12.287     | 9.713      | 4.217  | 0.442 |
| 340 |         |            |            |        |       |
| 360 | 14      | 11.202     | 8.798      | 4.100  | 0.440 |
| 380 | 15      | 12.141     | 9.859      | 4.769  | 0.448 |
| 400 | 16      | 12.169     | 9.831      | 4.651  | 0.447 |
| 420 | 17      | 12.195     | 9.805      | 4.548  | 0.446 |
| 440 |         |            |            |        |       |
| 460 | 18      | 14.257     | 11.743     | 5.122  | 0.452 |
| 480 | 19      | 14.273     | 11.727     | 5.057  | 0.451 |
| 500 | 20      | 15.265     | 12.735     | 5.489  | 0.455 |
| 530 | 21      | 15.249     | 12.751     | 5.559  | 0.455 |
| 560 | 22      | 15.241     | 12.759     | 5.597  | 0.456 |
| 580 | 23      | 16.277     | 13.723     | 5.831  | 0.457 |
| 600 | 24      | 16.252     | 13.748     | 5.951  | 0.458 |

The above figures are unitary values. For the appropriate frequency, multiply by application RPM.

TABLE 19. HEAVY SERIES

|     |                                | Inner Race | Outer Race | Roller | Cage  |
|-----|--------------------------------|------------|------------|--------|-------|
| mm  | in.                            | hz         | hz         | hz     | hz    |
| –   | –                              | –          | –          | –      | –     |
| –   | –                              | –          | –          | –      | –     |
| –   | –                              | –          | –          | –      | –     |
| –   | –                              | –          | –          | –      | –     |
| –   | –                              | –          | –          | –      | –     |
| 100 | 3 <sup>1</sup> / <sub>16</sub> | 6.073      | 3.927      | 2.222  | 0.393 |
| 105 | 4                              |            |            |        |       |
| 110 | 4 <sup>3</sup> / <sub>16</sub> | 5.983      | 4.017      | 2.446  | 0.402 |
| 120 | 4 <sup>1</sup> / <sub>2</sub>  |            |            |        |       |
| 125 | 4 <sup>1</sup> / <sub>16</sub> | 7.114      | 4.886      | 2.601  | 0.407 |
| 130 | 5                              |            |            |        |       |
| 135 | 5 <sup>3</sup> / <sub>16</sub> | 8.259      | 5.741      | 2.690  | 0.410 |
| 140 | 5 <sup>1</sup> / <sub>2</sub>  |            |            |        |       |
| 150 | 5 <sup>1</sup> / <sub>16</sub> | 7.190      | 4.810      | 2.422  | 0.401 |
| 155 | 6                              |            |            |        |       |
| 160 | 6 <sup>7</sup> / <sub>16</sub> | 7.159      | 4.841      | 2.491  | 0.403 |
| 170 | 6 <sup>1</sup> / <sub>2</sub>  |            |            |        |       |
| 175 | 6 <sup>1</sup> / <sub>16</sub> | 8.243      | 5.757      | 2.727  | 0.411 |
| 180 | 7                              |            |            |        |       |
| 190 | 7 <sup>1</sup> / <sub>4</sub>  | 8.221      | 5.779      | 2.779  | 0.413 |
| 200 | 8                              |            |            |        |       |
| 220 | 8 <sup>1</sup> / <sub>2</sub>  | 8.102      | 5.898      | 3.097  | 0.421 |
| 230 | 9                              |            |            |        |       |
| 240 | 9 <sup>1</sup> / <sub>2</sub>  | 8.131      | 5.869      | 3.013  | 0.419 |
| 260 | 10                             |            |            |        |       |
| 280 | 11                             | 9.197      | 6.803      | 3.267  | 0.425 |
| 300 | 12                             | 9.192      | 6.808      | 3.280  | 0.425 |
| 320 | 13                             | 9.246      | 6.754      | 3.132  | 0.422 |
| 340 | 14                             | 10.224     | 7.776      | 3.609  | 0.432 |
| 360 |                                |            |            |        |       |
| 380 | 15                             | 10.250     | 7.750      | 3.530  | 0.431 |
| 400 | 16                             |            |            |        |       |
| 420 | 17                             | 11.263     | 8.737      | 3.895  | 0.437 |
| 440 |                                |            |            |        |       |
| 460 | 18                             | 10.170     | 7.830      | 3.781  | 0.435 |
| –   | –                              | –          | –          | –      | –     |
| 500 | 20                             | 10.172     | 7.828      | 3.773  | 0.435 |
| 530 | 21                             |            |            |        |       |
| 560 | 22                             | 12.174     | 9.826      | 4.630  | 0.447 |
| 580 | 23                             | 12.240     | 9.760      | 4.378  | 0.444 |
| 600 | 24                             |            |            |        |       |

The above figures are unitary values. For the appropriate frequency, multiply by application RPM.

## SHAFT CONSIDERATIONS

It is essential that the shaft on to which the bearing is to be mounted has been produced to the correct size and tolerance for the operating conditions. If replacing a bearing in an existing system, the shaft must be checked to establish if any wear or

damage has taken place. The table below may be followed for both the manufacture of new shafts and the inspection of existing shafts.

TABLE 20. SHAFT CONSIDERATIONS

| Shaft Dia.                   | dn<50000<br>& C/P>10 | 50000<dn<150000<br>& C/P>10 | 50000<dn<150000<br>& C/P<10 | dn>150000            | Cylindricity of Shaft |
|------------------------------|----------------------|-----------------------------|-----------------------------|----------------------|-----------------------|
| Over - Incl.                 | h9                   | h8                          | h7                          | h6                   | IT6                   |
| $\mu\text{m}$<br>in.         | $\mu\text{m}$<br>in. | $\mu\text{m}$<br>in.        | $\mu\text{m}$<br>in.        | $\mu\text{m}$<br>in. | $\mu\text{m}$<br>in.  |
| 0 - 50<br>0 - 2              | -62<br>-2.5          | -39<br>-1.5                 | -25<br>-1                   | -16<br>-0.6          | -16<br>-0.6           |
| 50 - 80<br>2 - 3             | -74<br>-3            | -46<br>-1.8                 | -30<br>-1.2                 | -19<br>-0.7          | -19<br>-0.7           |
| 80 - 120<br>3 - 5            | -87<br>-3.5          | -54<br>-2.1                 | -35<br>-1.4                 | -22<br>-0.9          | -22<br>-0.9           |
| 120 - 180<br>5 - 7           | -100<br>-3.9         | -63<br>-2.5                 | -40<br>-1.6                 | -25<br>-1            | -25<br>-1             |
| 180 - 250<br>7 - 10          | -115<br>-4.5         | -72<br>-2.8                 | -46<br>-1.8                 | -29<br>-1.2          | -29<br>-1.2           |
| 250 - 315<br>10 - 12 1/2     | -130<br>-5.1         | -81<br>-3.2                 | -52<br>-2                   | -32<br>-1.3          | -32<br>-1.3           |
| 315 - 400<br>12 1/2 - 15 1/2 | -140<br>-5.5         | -89<br>-3.5                 | -57<br>-2.2                 | -36<br>-1.4          | -36<br>-1.4           |
| 400 - 500<br>15 1/2 - 19 1/2 | -155<br>-6.1         | -97<br>-3.8                 | -63<br>-2.5                 | -40<br>-1.6          | -40<br>-1.6           |
| 19 1/2 - 24"<br>500 - 600 mm | -175<br>-6.9         | -110<br>-4.3                | -70<br>-2.8                 | -44<br>-1.7          | -44<br>-1.7           |

dn value = shaft size (mm) x RPM  
 C = Bearing dynamic capacity (kN)  
 P = Equivalent bearing load

## RECESS MOUNTING

In applications where the resultant axial load exceeds 50 percent of the  $C_a$  rating for the bearing, the shaft design should include either a recess for bearing seating or grooves to accommodate retaining rings. Such an arrangement should also be considered if the unit is subjected to shock loads, fluctuations in temperature over 100° C (212° F) or the shaft is vertical.

The dimensions for producing an appropriate recess or for governing the position and size of the retaining rings if used are derived from table 21.

TABLE 21. RECESS MOUNTING

| Journal Diameter<br>d           | Shoulder Diameter<br>D | Fillet Radii | Shoulder Height<br>B | Recess Width<br>R                              | Squareness of Abutment Faces |
|---------------------------------|------------------------|--------------|----------------------|------------------------------------------------|------------------------------|
| mm<br>in.                       | mm<br>in.              | mm<br>in.    | mm<br>in.            | mm<br>in.                                      | mm<br>in.                    |
| 40 - 90<br>1 1/2 - 3 1/2        | d + 5<br>d + 1/4       | 1.2<br>3/64  | 2.5<br>1/8           | C + 0.1<br>C + 0.3<br>C + 0.004<br>C + 0.012   | 0.1<br>0.004                 |
| Over 90 - 150<br>Over 3 1/2 - 6 | d + 10<br>d + 3/8      | 2.0<br>3/64  | 5.0<br>3/16          | C + 0.15<br>C + 0.40<br>C + 0.006<br>C + 0.016 | 0.1<br>0.004                 |
| Over 155<br>Over 6              | d + 10<br>d + 3/8      | 2.3<br>3/32  | 5.0<br>3/16          | C + 0.2<br>C + 0.5<br>C + 0.008<br>C + 0.02    | 0.1<br>0.004                 |

N.B. Width of recesses for standard bearings may be different from that used for existing products. Please consult a Timken engineer for bearings suitable for other recess sizes.

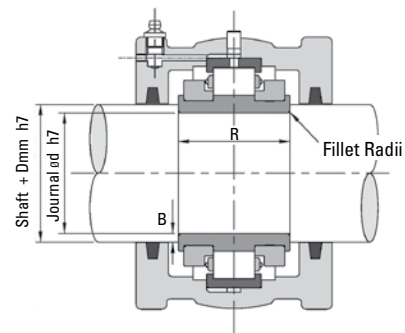

Fig. 16. Recess Mounting.

## SEALING ARRANGEMENTS

Any bearing, housing and support unit that is not suitably sealed against its surrounding environment is unlikely to achieve its full potential, either in terms of performance or life span. The prevention of ingress of foreign materials and contaminants is paramount and should be considered as early in the selection process as possible.

A wide variety of sealing solutions are available to users of Timken products as off-the-shelf arrangements. This range will cover the vast majority of operating environments found throughout all industries. To cover those situations where a proprietary arrangement is not suitable, Timken is able to work closely with designers and end users to develop and manufacture custom solutions tailored to specific applications.

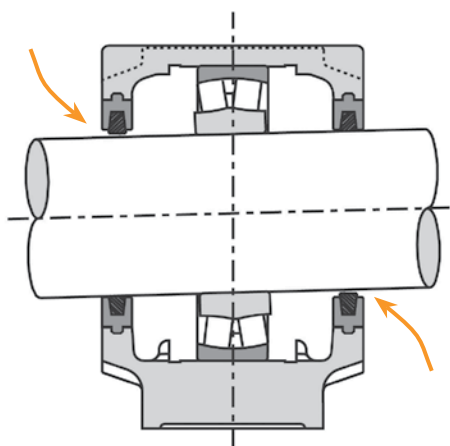

Fig. 17. Seal ineffective.



Fig. 18. Steel industry applications are ideal for Timken Mounted Split Cylindrical Roller Bearings.

Timken units have inherent advantages over traditional solid bearing arrangements when considering sealing. The spherical location between housing and support ensures that whichever type of seal is used, it will always remain concentric to the shaft.

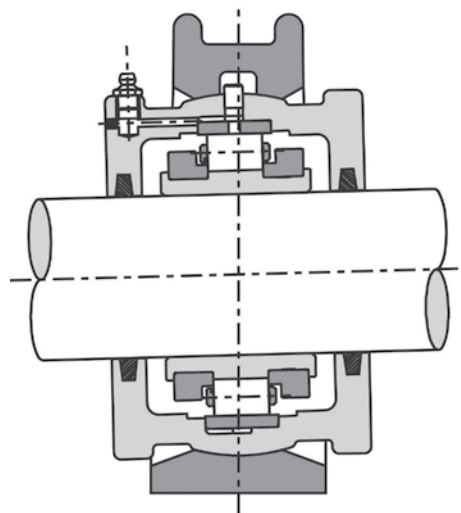

Fig. 19. Seal remains concentric.



Fig. 20. Timken Mounted Split Cylindrical Roller Bearing is shown here in a steel industry application.

### ALUMINIUM TRIPLE LABYRINTH

A precision machined, non-contacting seal suitable for both high speed and general applications. Once fitted the seal revolves with the shaft. The seal grips the shaft via two split O-rings fitted to the bore of the seal. Timken triple labyrinth seals are fitted with high-temperature Viton cord as standard.

|                |                                       |
|----------------|---------------------------------------|
| Max. Speed     | As Bearing                            |
| Temp. Range    | -20° C to +175° C (-4° F to + 347° F) |
| Shaft Finish   | 3.2µm Ra                              |
| Suffix Letters | <b>ATL</b>                            |

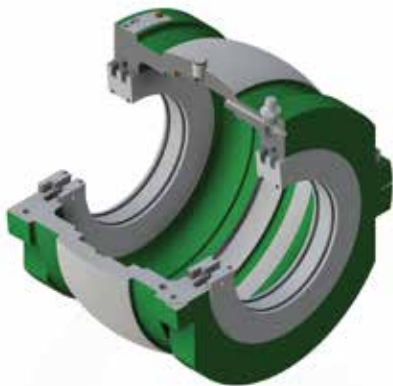

Fig. 21. Aluminium Triple Labyrinth.

### KEVLAR® PACKING SEAL

This recent addition to the sealing range has proved highly effective in areas having the potential for fine particle contaminants such as cement or ash. Please consult a Timken engineer for more information.

|                |                                          |
|----------------|------------------------------------------|
| Max. Speed     | As bearing                               |
| Temp. Range    | -100° C to +280° C (-148° F to + 536° F) |
| Shaft Finish   | 1.6µm Ra                                 |
| Suffix Letters | <b>KPS</b>                               |

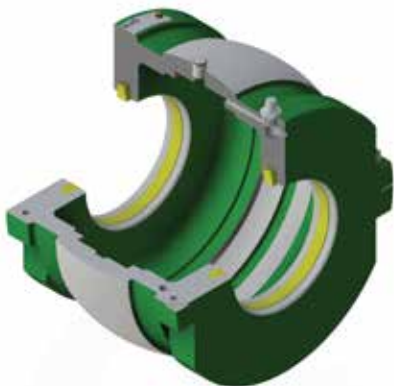

Fig. 22. Kevlar Packing Seal.

### VITON SINGLE LIP

For environments involving moderate liquid splashing but not submersion. Should be avoided where abrasive particles are also present as this can lead to shaft wear in the seal area.

|                |                                        |
|----------------|----------------------------------------|
| Max. Speed     | dN(mm)<150000                          |
| Temp. Range    | -34° C to +204° C (-30° F to + 400° F) |
| Shaft Finish   | 3.2µm Ra                               |
| Suffix Letters | <b>RSS</b>                             |

Note: d = shaft diameter, N = RPM

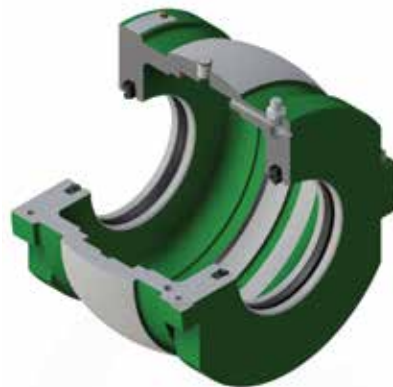

Fig. 23. Viton Single Lip.

### HIGH-TEMPERATURE PACKING

A self-lubricating high temperature packing seal based around PTFE and graphite.

|                |                                         |
|----------------|-----------------------------------------|
| Max. Speed     | dN(mm)<150000                           |
| Temp. Range    | -60° C to + 300° C (-76° F to + 572° F) |
| Shaft Finish   | 1.2µm Ra                                |
| Suffix Letters | <b>HTPS</b>                             |

Note: d = shaft diameter, N = RPM

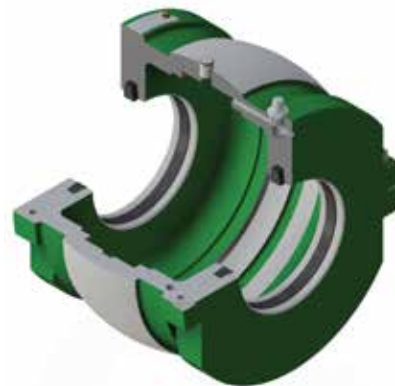

Fig. 24. High-Temperature Packing.



### FELT SEAL

This type of seal is supplied as standard with all Timken housings up to a bore size of 12 inch. Consisting of felt strips made from blended fibers. Seals are supplied dry and need to be soaked in oil prior to fitting.

|              |                                       |
|--------------|---------------------------------------|
| Max. Speed   | dN(mm)<150000                         |
| Temp. Range  | -60° C to +100° C (-76° F to +212° F) |
| Shaft Finish | 1.6µm Ra                              |

Note: d = shaft diameter, N = RPM

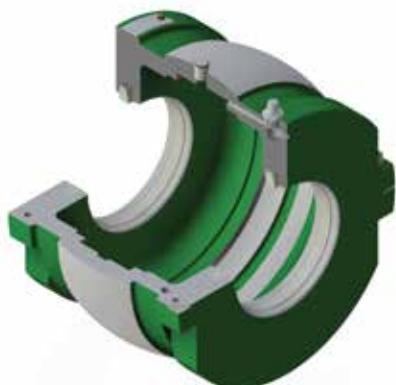

Fig. 25. Felt Seal.

### LABYRINTH GREASE GROOVE

For shaft sizes over 12 in., housings are supplied with a close-fitting labyrinth groove machined into the housing. No additional seal is added. For harsh environments, alternative sealing arrangements are available.

|                |            |
|----------------|------------|
| Max. Speed     | As Bearing |
| Temp. Range    | As Bearing |
| Shaft Finish   | 3.2µm Ra   |
| Suffix Letters | <b>LAB</b> |

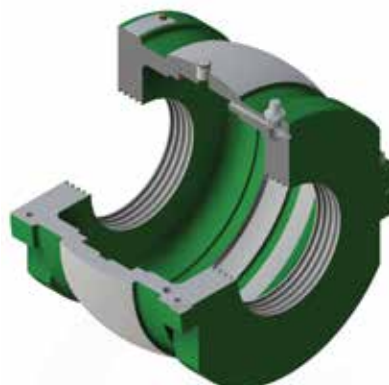

Fig. 27. Labyrinth Grease Groove.

### SINGLE-LIP WITH GARTER SPRING AND RETAINING PLATE

A more specialized seal for very wet environments with heavy splash. This type of seal is not suitable for continuous submersion without due consideration being given to sealing of the housing joint and any other possible points of liquid entry. Please consult a Timken engineer for more information.

|                |                                       |
|----------------|---------------------------------------|
| Max. Speed     | dN(mm)<150000                         |
| Temp. Range    | -20° C to +100° C (-4° F to + 212° F) |
| Shaft Finish   | 0.8µm Ra                              |
| Suffix Letters | <b>WSRP</b>                           |

Note: d = shaft diameter, N = RPM



Fig. 26. Single-Lip with Garter Spring and Retaining Plate.

### COMBINATION SEAL

This seal combines a labyrinth grease seal with grease purge and the strip seal of your choice (felt, RSS, HTPS or KPS). This combination is ideal for harsh environments with high levels of contamination. Only available for shaft sizes above 12 inches.

|                |                                    |
|----------------|------------------------------------|
| Max. Speed     | As per the chosen strip seal type. |
| Temp. Range    | As per the chosen strip seal type. |
| Shaft Finish   | 1.6µm Ra                           |
| Suffix Letters | <b>LABLUB</b>                      |

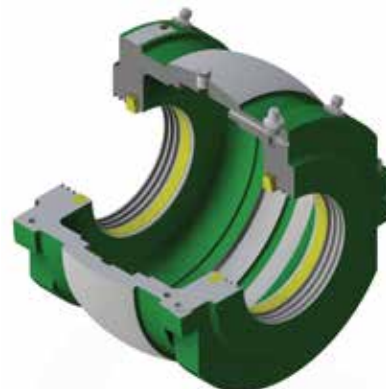

Fig. 28. Combination Seal.

# TRIPLE LABYRINTH HOUSING AND SEAL REFERENCES

TABLE 22. LIGHT SERIES

| Shaft (d) |         | Triple Labyrinth Seal Reference |        | Housing Reference | Retained Expansion | Shaft (d) |         | Triple Labyrinth Seal Reference |         | Housing Reference | Retained Expansion |
|-----------|---------|---------------------------------|--------|-------------------|--------------------|-----------|---------|---------------------------------|---------|-------------------|--------------------|
| mm        | in.     | mm                              | in.    |                   |                    | mm        | in.     | mm                              | in.     |                   |                    |
| 35        | 1 3/16  | 35MMATL                         | 103ATL | LS1HRTL           | LS1HRTL            | 240       | 9 1/2   | 240MMATL                        | 908ATL  | LS15HRTL          | LS15HRTL           |
|           | 1 1/4   |                                 | 104ATL |                   |                    |           | 912ATL  |                                 |         |                   |                    |
| 40        | 1 7/16  | 40MMATL                         | 107ATL | LS1HXTL           | LS1HXTL            | 250       | 9 3/4   | 250MMATL                        | 1000ATL | LS16HRTL          | LS16HXTL           |
|           | 1 1/2   |                                 | 108ATL |                   |                    |           | 1008ATL |                                 |         |                   |                    |
| 45        | 1 11/16 | 45MMATL                         | 111ATL | LS2HRTL           | LS2HRTL            | 260       | 10 1/2  | 260MMATL                        | 1008ATL | LS16HRTL          | LS16HXTL           |
|           | 1 3/4   |                                 | 112ATL |                   |                    |           |         |                                 | 1012ATL |                   |                    |
| 50        | 1 15/16 | 50MMATL                         | 115ATL | LS2HXTL           | LS2HXTL            | 270       | 11      | 270MMATL                        | 1100ATL | LS17HRTL          | LS17HXTL           |
|           | 2       |                                 | 200ATL |                   |                    |           |         |                                 | 1108ATL |                   |                    |
| 55        | 2 3/16  | 55MMATL                         | 203ATL | LS3HRTL           | LS3HRTL            | 300       | 11 1/2  | 300MMATL                        | 1200ATL | LS17HRTL          | LS17HXTL           |
|           | 2 1/4   |                                 | 204ATL |                   |                    |           |         |                                 | 1200ATL |                   |                    |
| 60        | 2 7/16  | 60MMATL                         | 207ATL | LS3HXTL           | LS3HXTL            | 305       | 12      | 305MMATL                        | 1200ATL | LS18HRTL          | LS18HXTL           |
|           | 2 1/2   |                                 | 208ATL |                   |                    |           |         |                                 | 1208ATL |                   |                    |
| 70        | 2 11/16 | 70MMATL                         | 211ATL | LS4HRTL           | LS4HRTL            | 320       | 12 1/2  | 320MMATL                        | 1300ATL | LS18HRTL          | LS18HXTL           |
|           | 2 3/4   |                                 | 212ATL |                   |                    |           |         |                                 | 1300ATL |                   |                    |
| 75        | 2 15/16 | 75MMATL                         | 215ATL | LS4HXTL           | LS4HXTL            | 330       | 13      | 330MMATL                        | 1300ATL | LS19HRTL          | LS19HXTL           |
|           | 3       |                                 | 300ATL |                   |                    |           |         |                                 | 1400ATL |                   |                    |
| 80        | 3 3/16  | 80MMATL                         | 303ATL | LS5HRTL           | LS5HRTL            | 340       | 14      | 340MMATL                        | 1400ATL | LS19HRTL          | LS19HXTL           |
|           | 3 1/4   |                                 | 304ATL |                   |                    |           |         |                                 | 1400ATL |                   |                    |
| 85        | 3 7/16  | 85MMATL                         | 307ATL | LS5HXTL           | LS5HXTL            | 350       | 15      | 350MMATL                        | 1500ATL | LS20HRTL          | LS20HXTL           |
|           | 3 1/2   |                                 | 308ATL |                   |                    |           |         |                                 | 1500ATL |                   |                    |
| 100       | 3 11/16 | 100MMATL                        | 311ATL | LS6HRTL           | LS6HRTL            | 360       | 16      | 360MMATL                        | 1600ATL | LS21HRTL          | LS21HXTL           |
|           | 3 3/4   |                                 | 312ATL |                   |                    |           |         |                                 | 1600ATL |                   |                    |
| 105       | 3 15/16 | 105MMATL                        | 315ATL | LS6HXTL           | LS6HXTL            | 380       | 17      | 380MMATL                        | 1700ATL | LS22HRTL          | LS22HXTL           |
|           | 4       |                                 | 400ATL |                   |                    |           |         |                                 | 1800ATL |                   |                    |
| 110       | 4 3/16  | 110MMATL                        | 403ATL | LS7HRTL           | LS7HRTL            | 400       | 18      | 400MMATL                        | 1800ATL | LS23HRTL          | LS23HXTL           |
|           | 4 1/4   |                                 | 404ATL |                   |                    |           |         |                                 | 1800ATL |                   |                    |
| 115       | 4 7/16  | 115MMATL                        | 407ATL | LS7HXTL           | LS7HXTL            | 420       | 19      | 420MMATL                        | 1900ATL | LS24HRTL          | LS24HXTL           |
|           | 4 1/2   |                                 | 408ATL |                   |                    |           |         |                                 | 1900ATL |                   |                    |
| 120       | 4 11/16 | 120MMATL                        | 411ATL | LS8HRTL           | LS8HRTL            | 440       | 20      | 440MMATL                        | 2000ATL | LS24HRTL          | LS24HXTL           |
|           | 4 3/4   |                                 | 412ATL |                   |                    |           |         |                                 | 2000ATL |                   |                    |
| 125       | 4 15/16 | 125MMATL                        | 415ATL | LS8HXTL           | LS8HXTL            | 460       | 21      | 460MMATL                        | 2100ATL | LS25HRTL          | LS25HXTL           |
|           | 5       |                                 | 500ATL |                   |                    |           |         |                                 | 2100ATL |                   |                    |
| 135       | 5 3/16  | 135MMATL                        | 503ATL | LS9HRTL           | LS9HRTL            | 500       | 22      | 500MMATL                        | 2200ATL | LS26HRTL          | LS26HXTL           |
|           | 5 1/4   |                                 | 504ATL |                   |                    |           |         |                                 | 2200ATL |                   |                    |
| 140       | 5 7/16  | 140MMATL                        | 507ATL | LS9HXTL           | LS9HXTL            | 530       | 23      | 530MMATL                        | 2300ATL | LS27HRTL          | LS27HXTL           |
|           | 5 1/2   |                                 | 508ATL |                   |                    |           |         |                                 | 2300ATL |                   |                    |
| 150       | 5 11/16 | 150MMATL                        | 511ATL | LS10HRTL          | LS10HRTL           | 560       | 24      | 560MMATL                        | 2400ATL | LS28HRTL          | LS28HXTL           |
|           | 5 3/4   |                                 | 512ATL |                   |                    |           |         |                                 | 2400ATL |                   |                    |
| 155       | 5 15/16 | 155MMATL                        | 515ATL | LS10HXTL          | LS10HXTL           | 580       | 25      | 580MMATL                        | 2500ATL | LS28HRTL          | LS28HXTL           |
|           | 6       |                                 | 600ATL |                   |                    |           |         |                                 | 2500ATL |                   |                    |
| 160A      | 6       | 160MMATL                        | -      | LS10HRTLE0548     | LS10HXTLE0548      | 500       | 20      | 500MMATL                        | 2000ATL | LS25HRTL          | LS25HXTL           |
| 160       | 6 7/16  | 160MMATL                        | 607ATL | LS11HRTL          | LS11HRTL           | 530       | 21      | 530MMATL                        | 2100ATL | LS26HRTL          | LS26HXTL           |
|           | 6 1/2   |                                 | 608ATL |                   |                    |           |         |                                 | 2100ATL |                   |                    |
| 170       | 6 11/16 | 170MMATL                        | 611ATL | LS12HRTL          | LS12HRTL           | 560       | 22      | 560MMATL                        | 2200ATL | LS27HRTL          | LS27HXTL           |
|           | 6 3/4   |                                 | 612ATL |                   |                    |           |         |                                 | 2200ATL |                   |                    |
| 175       | 6 15/16 | 175MMATL                        | 615ATL | LS12HXTL          | LS12HXTL           | 580       | 23      | 580MMATL                        | 2300ATL | LS28HRTL          | LS28HXTL           |
|           | 7       |                                 | 700ATL |                   |                    |           |         |                                 | 2300ATL |                   |                    |
| 180       | 7       | 180MMATL                        | 704ATL | LS13HRTL          | LS13HRTL           | 600       | 24      | 600MMATL                        | 2400ATL | LS29HRTL          | LS29HXTL           |
|           | 7 1/4   |                                 | 708ATL |                   |                    |           |         |                                 | 2400ATL |                   |                    |
| 190       | 7 1/2   | 190MMATL                        | 708ATL | LS13HXTL          | LS13HXTL           | 600       | 24      | 600MMATL                        | 2400ATL | LS29HRTL          | LS29HXTL           |
|           | 7 15/16 |                                 | 715ATL |                   |                    |           |         |                                 | 2400ATL |                   |                    |
| 200       | 8       | 200MMATL                        | 800ATL | LS14HRTL          | LS14HRTL           | 600       | 24      | 600MMATL                        | 2400ATL | LS29HRTL          | LS29HXTL           |
|           | 8 1/2   |                                 | 808ATL |                   |                    |           |         |                                 | 2400ATL |                   |                    |
| 220       | 8 7/8   | 220MMATL                        | 814ATL | LS14HXTL          | LS14HXTL           | 600       | 24      | 600MMATL                        | 2400ATL | LS29HRTL          | LS29HXTL           |
|           | 9       |                                 | 900ATL |                   |                    |           |         |                                 | 2400ATL |                   |                    |

TABLE 23. MEDIUM SERIES

| Shaft (d) |         | Triple Labyrinth Seal Reference  |             | Housing Reference              | Retained Expansion |
|-----------|---------|----------------------------------|-------------|--------------------------------|--------------------|
| mm        | in.     | mm                               | in.         |                                |                    |
| -         | -       | -                                | -           | -                              |                    |
| 45        | 1 11/16 | 45MMATL<br>50MMATL               | 111ATL      | MS3HRTL<br>MS3HXTL             |                    |
| 50        | 1 3/4   |                                  | 112ATL      |                                |                    |
|           | 1 15/16 |                                  | 115ATL      |                                |                    |
|           | 2       |                                  | 200ATL      |                                |                    |
| 55        | 2 3/16  | 55MMATL<br>60MMATL<br>65MMATL    | 203ATL      | MS4HRTL<br>MS4HXTL             |                    |
| 60        | 2 1/4   |                                  | 204ATL      |                                |                    |
| 65        | 2 7/16  |                                  | 207ATL      |                                |                    |
|           | 2 1/2   |                                  | 208ATL      |                                |                    |
| 70        | 2 11/16 | 70MMATL<br>75MMATL               | 211ATL      | MS5HRTL<br>MS5HXTL             |                    |
| 75        | 2 3/4   |                                  | 212ATL      |                                |                    |
|           | 2 15/16 |                                  | 215ATL      |                                |                    |
|           | 3       |                                  | 300ATL      |                                |                    |
| 80        | 3 3/16  | 80MMATL<br>85MMATL<br>90MMATL    | 303ATL      | MS6HRTL<br>MS6HXTL             |                    |
| 85        | 3 1/4   |                                  | 304ATL      |                                |                    |
| 90        | 3 7/16  |                                  | 307ATL      |                                |                    |
|           | 3 1/2   |                                  | 308ATL      |                                |                    |
| 100       | 3 11/16 | 100MMATL<br>105MMATL             | 311ATL      | MS7HRTL<br>MS7HXTL             |                    |
| 105       | 3 3/4   |                                  | 312ATL      |                                |                    |
|           | 3 15/16 |                                  | 315ATL      |                                |                    |
|           | 4       |                                  | 400ATL      |                                |                    |
| 110       | 4 3/16  | 110MMATL<br>115MMATL             | 403ATL      | MS8HRTL<br>MS8HXTL             |                    |
| 115       | 4 1/4   |                                  | 404ATL      |                                |                    |
|           | 4 7/16  |                                  | 407ATL      |                                |                    |
|           | 4 1/2   |                                  | 408ATL      |                                |                    |
| 120       | 4 11/16 | 120MMATL<br>125MMATL<br>130MMATL | 411ATL      | MS10HRTL<br>MS10HXTL           |                    |
| 125       | 4 3/4   |                                  | 412ATL      |                                |                    |
| 130       | 4 15/16 |                                  | 415ATL      |                                |                    |
|           | 5       |                                  | 500ATL      |                                |                    |
| 135       | 5 3/16  | 135MMATL<br>140MMATL             | 503ATL      | MS30HRTL<br>MS30HXTL           |                    |
| 140       | 5 1/4   |                                  | 504ATL      |                                |                    |
|           | 5 7/16  |                                  | 507ATL      |                                |                    |
|           | 5 1/2   |                                  | 508ATL      |                                |                    |
| 150       | 5 11/16 | 150MMATL<br>155MMATL             | 511ATL      | MS31HRTL<br>MS31HXTL           |                    |
| 155       | 5 3/4   |                                  | 512ATL      |                                |                    |
|           | 5 15/16 |                                  | 515ATL      |                                |                    |
|           | 6       |                                  | 600ATL      |                                |                    |
| 160A      | 6       | 160MMATL                         | -           | MS31HRTLE0548<br>MS31HXTLE0548 |                    |
| 160       | 6 7/16  | 160MMATL<br>170MMATLE0547        | 607ATL      | MS32HRTL<br>MS32HXTL           |                    |
| 170       | 6 1/2   |                                  | 608ATL      |                                |                    |
|           | 6 11/16 |                                  | 611ATLE0547 |                                |                    |
|           | 6 3/4   |                                  | 612ATLE0547 |                                |                    |
| 175       | 6 15/16 | 175MMATL<br>180MMATL             | 615ATL      | MS33HRTL<br>MS33HXTL           |                    |
| 180       | 7       |                                  | 700ATL      |                                |                    |
| 190       | 7 1/4   | 190MMATL<br>200MMATL             | 704ATL      | MS34HRTL<br>MS34HXTL           |                    |
| 200       | 7 1/2   |                                  | 708ATL      |                                |                    |
|           | 7 15/16 |                                  | 715ATL      |                                |                    |
|           | 8       |                                  | 800ATL      |                                |                    |
| 220       | 8 1/2   | 220MMATL<br>230MMATL             | 808ATL      | MS35HRTL<br>MS35HXTL           |                    |
| 230       | 8 7/8   |                                  | 814ATL      |                                |                    |
|           | 9       |                                  | 900ATL      |                                |                    |

| Shaft (d) |                      | Triple Labyrinth Seal Reference |                             | Housing Reference                                      | Retained Expansion |
|-----------|----------------------|---------------------------------|-----------------------------|--------------------------------------------------------|--------------------|
| mm        | in.                  | mm                              | in.                         |                                                        |                    |
| 240       | 9 1/2<br>9 3/4<br>10 | 240MMATL                        | 908ATL<br>912ATL<br>1000ATL | MS36HRTL<br>MS36HXTL                                   |                    |
| 260       | 10 1/2               | 260MMATL                        | 1008ATL                     | MS36HRTLE0548<br>MS36HXTLE0548<br>MS37HRTL<br>MS37HXTL |                    |
| 270       | 10 3/4               | 270MMATL                        | 1012ATL                     |                                                        |                    |
| 280       | 11                   | 280MMATL                        | 1100ATL                     |                                                        |                    |
| 300       | 11 1/2               | 300MMATL                        | 1108ATL                     | MS38HRTL<br>MS38HXTL                                   |                    |
| 305       | 12                   | 305MMATL                        | 1200ATL                     |                                                        |                    |
| 320       | 12 1/2               | 320MMATL                        | 1208ATL                     | MS39HRTL<br>MS39HXTL                                   |                    |
| 330       | 13                   | 330MMATL                        | 1300ATL                     |                                                        |                    |
| 340       | 14                   | 340MMATL                        | 1400ATL                     | MS40HRTL<br>MS40HXTL                                   |                    |
| 360       |                      | 360MMATLE0547                   |                             |                                                        |                    |
| 380       | 15                   | 380MMATL                        | 1500ATL                     | MS41HRTL<br>MS41HXTL                                   |                    |
| 400       | 16                   | 400MMATL                        | 1600ATL                     | MS42HRTL<br>MS42HXTL                                   |                    |
| 420       | 17                   | 420MMATL                        | 1700ATL                     | MS43HRTL<br>MS43HXTL                                   |                    |
| 440       | 18                   | 440MMATL                        | 1800ATL                     | MS44HRTL<br>MS44HXTL                                   |                    |
| 460       |                      | 460MMATL                        |                             |                                                        |                    |
| 480       | 19                   | 480MMATL                        | 1900ATL                     | MS45HRTL<br>MS45HXTL                                   |                    |
| 500       | 20                   | 500MMATL                        | 2000ATL                     | MS46HRTL<br>MS46HXTL                                   |                    |
| 530       | 21                   | 530MMATL                        | 2100ATL                     | MS47HRTL<br>MS47HXTL                                   |                    |
| 560       | 22                   | 560MMATL                        | 2200ATL                     | MS48HRTL<br>MS48HXTL                                   |                    |
| 580       | 23                   | 580MMATL                        | 2300ATL                     | MS49HRTL<br>MS49HXTL                                   |                    |
| 600       | 24                   | 600MMATL                        | 2400ATL                     | MS50HRTL<br>MS50HXTL                                   |                    |

# TRIPLE LABYRINTH HOUSING AND SEAL REFERENCES

TABLE 24. HEAVY SERIES

| Shaft (d) |         | Triple Labyrinth Seal Reference |             | Housing Reference | Retained Expansion |
|-----------|---------|---------------------------------|-------------|-------------------|--------------------|
| mm        | in.     | mm                              | in.         |                   |                    |
| -         | -       | -                               | -           | -                 | -                  |
| -         | -       | -                               | -           | -                 | -                  |
| -         | -       | -                               | -           | -                 | -                  |
| -         | -       | -                               | -           | -                 | -                  |
| -         | -       | -                               | -           | -                 | -                  |
| 100       | 3 1/16  | 100MMATL                        | 311ATL      | HS54HRTL          | -                  |
| 105       | 3 3/4   |                                 | 312ATL      |                   |                    |
|           | 3 15/16 | 105MMATL                        | 315ATL      | HS54HRTL          | -                  |
|           | 4       |                                 | 400ATL      |                   |                    |
| 110       | 4 3/16  | 110MMATL                        | 403ATL      | HS55HRTL          | -                  |
| 115       | 4 1/4   |                                 | 404ATL      |                   |                    |
| 120       | 4 7/16  | 120MMATLE0547                   | 407ATL      | HS55HRTL          | -                  |
|           | 4 1/2   |                                 | 408ATL      |                   |                    |
| 125       | 4 11/16 | 125MMATL                        | 411ATL      | HS56HRTL          | -                  |
| 130       | 4 3/4   |                                 | 412ATL      |                   |                    |
|           | 4 15/16 | 130MMATL                        | 415ATL      | HS56HRTL          | -                  |
|           | 5       |                                 | 500ATL      |                   |                    |
| 135       | 5 3/16  | 135MMATL                        | 503ATL      | HS57HRTL          | -                  |
| 140       | 5 1/4   |                                 | 504ATL      |                   |                    |
|           | 5 7/16  | 140MMATL                        | 507ATL      | HS57HRTL          | -                  |
|           | 5 1/2   |                                 | 508ATL      |                   |                    |
| 150       | 5 11/16 | 150MMATL                        | 511ATL      | HS58HRTL          | -                  |
| 155       | 5 3/4   |                                 | 512ATL      |                   |                    |
|           | 5 15/16 | 155MMATL                        | 515ATL      | HS58HRTL          | -                  |
|           | 6       |                                 | 600ATL      |                   |                    |
| 160A      | 6       | 160MMATL                        | -           | HS58HRTL          | HS58HRTL           |
|           |         |                                 |             | HS58HRTL          | HS58HRTL           |
| 160       | 6 7/16  | 160MMATL                        | 607ATL      | HS59HRTL          | -                  |
| 170       | 6 1/2   |                                 | 608ATL      |                   |                    |
|           | 6 11/16 | 170MMATLE0547                   | 611ATLE0547 | HS59HRTL          | -                  |
|           | 6 3/4   |                                 | 612ATLE0547 |                   |                    |
| 175       | 6 15/16 | 175MMATL                        | 615ATL      | HS60HRTL          | -                  |
| 180       | 7       |                                 | 700ATL      |                   |                    |
| 190       | 7 1/4   | 190MMATL                        | 704ATL      | HS61HRTL          | -                  |
| 200       | 7 1/2   |                                 | 708ATL      |                   |                    |
|           | 7 15/16 | 200MMATL                        | 715ATL      | HS61HRTL          | -                  |
|           | 8       |                                 | 800ATL      |                   |                    |
| 220       | 8 1/2   | 220MMATL                        | 808ATL      | HS62HRTL          | -                  |
| 230       | 8 7/8   |                                 | 814ATL      |                   |                    |
|           | 9       | 230MMATL                        | 900ATL      | HS62HRTL          | HS62HRTL           |
| -         | -       | -                               | -           | -                 | -                  |

| Shaft (d) |        | Triple Labyrinth Seal Reference |          | Housing Reference | Retained Expansion |
|-----------|--------|---------------------------------|----------|-------------------|--------------------|
| mm        | in.    | mm                              | in.      |                   |                    |
| 240       | 9 1/2  | 240MMATL                        | 908ATL   | HS63HRTL          | -                  |
|           | 9 3/4  |                                 | 912ATL   |                   |                    |
|           | 10     |                                 | 1000ATL  |                   |                    |
| 260       | -      | 260MMATL                        | -        | HS63HRTL          | HS63HRTL           |
|           |        |                                 |          | HS63HRTL          | HS63HRTL           |
| 270       | 10 1/2 | 270MMATL                        | 1008ATL  | HS83HRTL          | -                  |
| 280       | 10 3/4 |                                 | 1012ATL  |                   |                    |
|           | 11     | 280MMATL                        | 1100ATL  | HS83HRTL          | HS83HRTL           |
| 300       | 11 1/2 | 300MMATL                        | 1108ATL  | HS65HRTL          | -                  |
| 305       | 12     |                                 | 305MMATL |                   |                    |
| 320       | 13     | 320MMATL                        | 1300ATL  | HS66HRTL          | HS66HRTL           |
| 340       | 14     | 340MMATL                        | 1400ATL  | HS86HRTL          | -                  |
| 360       |        |                                 |          |                   |                    |
| 380       | 15     | 380MMATL                        | 1500ATL  | HS68HRTL          | HS68HRTL           |
| 400       | -      | 400MMATL                        | -        | HS68HRTL          | HS68HRTL           |
|           |        |                                 |          | HS68HRTL          | HS68HRTL           |
| 420       | 17     | 420MMATL                        | 1700ATL  | HS89HRTL          | -                  |
| 440       |        |                                 |          |                   |                    |
| 460       | 18     | 460MMATL                        | 1800ATL  | HS90HRTL          | HS90HRTL           |
| 500       | 20     | 500MMATL                        | 2000ATL  | HS94HRTL          | HS94HRTL           |
| 530       | -      | 530MMATL                        | -        | HS94HRTL          | HS94HRTL           |
|           |        |                                 |          | HS94HRTL          | HS94HRTL           |
| 560       | 22     | 560MMATL                        | 2200ATL  | HS94HRTL          | HS94HRTL           |
| 580       | 23     | 580MMATL                        | 2300ATL  | HS95HRTL          | -                  |
| 600       |        |                                 |          |                   |                    |
| -         | -      | -                               | -        | -                 | -                  |

## BEARING LUBRICATION

The function of a lubricant in a rolling element bearing is to prevent metal-to-metal contact between components, prevent wear and protect against corrosion. Two methods of lubrication are normal grease and oil. In the case of Timken split bearings, grease lubrication is most often employed.

## GREASE LUBRICATION

Greases can be used to lubricate Timken split cylindrical roller bearings under most normal conditions. Grease is the preferred method of lubrication because it can be more easily retained within the bearing enclosure and housing, the latter simplifying sealing arrangements. Greases are a semi-solid lubricant generally consisting of a soap emulsified with mineral or synthetic oils. Other ingredients include rust inhibitors or extra pressure additives. The oils employed may be mineral or synthetic depending upon the application.

Timken bearings are heat treated to retain dimensional stability up to 140° C (284° F). At temperatures up to 100° C (212° F), standard high-quality greases may be used. We suggest good quality lithium soap or complex-based greases having extra pressure additives and a penetration number of 3. It is important to note that all values given in this catalog for axial capacity assume the use of grease with extra pressure (EP) additives. If EP additives are not present then axial capacity is reduced by 50 percent.

At temperatures exceeding 100° C (212° F) care must be taken to ensure that the correct thickener and viscosity of base oil are selected. The performance of grease at such temperatures is dependent on a stable thickener and the temperature/viscosity ratio of the base oil. A stable base oil and soap thickener are important, as is the ability of the oil to offer adequate viscosity at an elevated temperature.

In cases of water splash, calcium soap based greases may be used. These are particularly resistant to water wash out.

Care should be taken when mixing greases with different soap thickeners and base oil types. Please contact a Timken engineer for further advice.

For initial lubrication the bearing should always be well filled with grease. The remaining housing space should be filled as follows:

- At low speeds, not exceeding 25 percent of catalog speed rating, we suggest that the remaining housing space be fully filled with grease.
- At medium speeds, between 25 and 50 percent of catalog speed rating, the remaining housing space may be  $\frac{1}{3}$  to  $\frac{1}{2}$  filled with grease.
- At high speeds, exceeding 50 percent of catalog speed rating, the remaining housing space should be left empty.

## RE-LUBRICATION

The re-lubrication intervals will be dependent on the prevailing operating conditions.

Greases age and oxidize due to a number of considerations. These include load, speed, temperature, cleanliness, presence of water and even airflow through the bearing.

For retained-type bearings, initial re-lubrication intervals for guidance purposes would be 2-4 weeks with 0.1-0.2 ounces (3-6 mls) added. For expansion type bearings, initial re-lubrication intervals would be 3-4 months with 0.1-0.2 ounces (3-6 mls) added. More accurate intervals and quantities should be established from observations taken during bearing operation. If re-lubrication can be carried out while the bearing is in operation, this will allow for even distribution of the grease. This means of re-lubrication should only be undertaken if it is safe to do so.

## OIL LUBRICATION

Timken split cylindrical roller bearings are rarely lubricated with oil. In cases where oil is selected as a means of lubrication, then special consideration must be given to the bearing housing design and sealing.

There are three principal methods of oil lubrication:

### OIL SUMP

The oil sits in the bearing housing at a level approximately halfway up the bottom dead center rolling element. Oil circulation around the bearing is then provided via the bearing rotation agitating the oil sump. It is very important to provide a sufficiently dimensioned oil sump as too small a volume will result in increased frequency of oil change and elevated operating temperatures.

### OIL MIST

An oil/air mist is injected into the bearing via nozzles, normally a total oil loss system; this provides extremely high speed capability at high cost.

For further advice on oil selection and oil lubrication systems please consult a Timken engineer.

### OIL CIRCULATION

Oil is circulated into the bearing housing assembly from an external oil sump. This allows the oil to be cooled and filtered, additionally an external oil sump normally allows for a higher volume of oil. While being a more optimum solution, specialist housing designs must be provided. There are also cost and space considerations with such systems.

## ASSEMBLY AND MAINTENANCE

### SHAFT CHECK

When fitting bearings on both new and existing installations, the shaft need only be raised  $\frac{1}{16}$  to  $\frac{1}{4}$  inch. This should provide sufficient clearance to allow for easy fitting. Prior to the assembly of any bearing components the shaft must be checked for size, roundness and parallelism.



- Check a minimum of three positions along the journal length.
- Check a minimum of three positions around the shaft to establish roundness
- Shaft tolerances and shaft surface finish are given in the table on page 28.

### FITTING THE INNER RING

- Carefully unpack and clean the bearing removing all preservatives.
- Inner race locating clamping rings cannot be removed before the cage has been dismantled.
- Care must be taken that no damage occurs when cage halves are separated.



#### NOTE

*Spring clips should always be retained on one cage half.*

- Clean the shaft and lightly oil the bore of the inner race.

- Place the two inner race halves in approximately the correct position with the joints at the top and bottom. With the joints in that position it will allow easy access to the clamp ring screws later when they are tightened



- Ensure that the match marks (black band) in the clamp ring groove on one side of the race coincide.

There should be an equal gap at each joint. If there are no gaps do not proceed and contact a Timken engineer.

- Fit the inner race locating clamping rings. Ensure that the correct clamp ring is fitted in the corresponding groove. To assist in this the clamping rings are intentionally manufactured to different widths on the more popular sizes. In addition, the match-marking groove found on the inner race is repeated on the corresponding clamping ring.

- Make sure that the thrust faces are not damaged when the rings enter the grooves.



- The joints should be at 90 degrees to the inner race joints and the screws should be tightened in such a way that there are four equal gaps.
- Screws should only be finger tight so that the race can be adjusted axially into its final position.

## ASSEMBLY OF THE OUTER RACE INTO THE SEATING GROOVE IN THE HOUSING

- The housing must be cleaned thoroughly removing all preservatives. If reusing an existing housing it is essential that the outer race seating groove is clean and free of any hardened grease deposits or corrosion.
- Lightly oil the seating groove and the outside diameter of the outer race halves.
- Place the race halves of the expansion or retained type into the seating groove and ensure that:
  - The match marking numbers on the edge of each race half coincide.
  - The lubrication hole in the outer race is in the upper housing half.
  - The outer race joints should protrude equally above the housing joint faces.



If a retained bearing is being fitted:

- Pre-assemble the housing halves and fully tighten the joint socket head cap screws.
- Ensure that the joints are closed.
- Fit the pins and screws provided and tighten up evenly to ensure that the outer race is fixed square against the opposite shoulder of the seating groove.

Larger bearings (both retained and expansion) may require outer race retaining screws. If these are required, please ensure that the flat washers are not omitted. Once fitted, ensure that the end of the screw does not protrude above the race track surface.



- Separate the housing halves. These are now ready for final assembly.
- Fit the appropriate seals. The seal grooves in the standard housing are suitable for felt and synthetic rubber. If the bearing is inspected or replaced on an existing installation and the housing is re-used, we advise fitting new seals.

## PRE-FITTING THE LOWER HOUSING HALF

On existing installations it is often unnecessary to change the support if a bearing, or bearing and housing, has to be replaced. In such cases the support base bolts should not be touched to ensure that the replacement bearing and the old or new housing will be in the same position as previously. In new installations the support base should be positioned with the bolts finger tight. This will allow additional freedom of movement when aligning the inner and outer races.



## RETAINED BEARING

- Slide the pre-assembled bottom half into the support base.
- Line up the inner and outer race roller track by adjusting the inner ring sideways into the final position. The final position should be confirmed by passing one half of the cage and roller assembly between the inner and outer races. The cage half should pass freely round the lower half of the bearing without becoming jammed or trapped.
- Remove the bottom housing half and tighten the clamp ring socket head cap screws and fit the cage as explained below.

## EXPANSION BEARING

- As in the case of the retained bearing, slide in the pre-assembled bottom housing half.
- Line up the inner ring by adjusting it sideways until it is central with the outer race.
- The clearance between the inner race end faces and inside housing walls should be equal. If cage and rollers are assembled in this position the shaft can expand either side of the centre line by the amount shown in column 2 in table 25.
- When the position of the inner ring is satisfactory, remove the bottom half housing and tighten the clamp ring socket head cap screws and fit the cage as explained below.

A greater degree of expansion allowance can be obtained, but only in one direction. This is achieved by offsetting the inner race with respect to the housing. In this case the total amount of linear movement in service is given in column 3 of table 25.

TABLE 25. EXPANSION BEARING – ALLOWABLE LIMITS

| Group      | Maximum Expansion if Cage and Rollers are Assembled Central | Maximum Expansion |
|------------|-------------------------------------------------------------|-------------------|
| mm in.     | mm in.                                                      | mm in.            |
| 40<br>1 ½  | 3.0<br>⅛                                                    | 6<br>¼            |
| 50<br>2    | 3.0<br>⅛                                                    | 6<br>¼            |
| 60<br>2 ½  | 3.5<br>9/64                                                 | 7<br>9/32         |
| 70<br>3    | 4.0<br>5/32                                                 | 8<br>5/16         |
| 80<br>3 ½  | 6.0<br>¼                                                    | 12<br>½           |
| 100<br>4   | 5.5<br>7/32                                                 | 11<br>7/16        |
| 110<br>4 ½ | 5.5<br>7/32                                                 | 11<br>7/16        |
| 120<br>5   | 5.5<br>7/32                                                 | 11<br>7/16        |
| 140<br>5 ½ | 8.0<br>5/16                                                 | 16<br>5/8         |
| 150<br>6   | 8.0<br>5/16                                                 | 16<br>5/8         |

## TIGHTENING OF THE LOCATING CLAMPING RING SCREWS

- When the inner race is in its final position, tighten all four clamping ring screws equally.
- Use the correct hexagon key and a torque wrench.
- Tap down the locating thrust rings with a nylon mallet to ensure that they are seating down correctly within the grooves.
- Re-tighten and repeat the tapping down until the screws are fully tight.
- Torque values for the various screw sizes are given in the tables at the end of this section. If a screw is lost it must be replaced using a high tensile socket head cap screw grade, 12.9.





## FITTING THE CAGE

- Grease the inner race roller track and cage.
- Place the cage halves around the inner race ensuring that the match mark numbers on the edge of each cage half are the same and coincide at one joint.
- Press the cage halves into the clip ensuring that the roll pins are fully located.
- Check that the cage assembly runs freely on the inner race.
- Fully pack the cage and roller assembly with the correct type of grease.



- Fit the upper housing half then tighten the housing joint screws. Torque values for housing screws are given in the tables on pages 40-42. Check that there is no gap at the joints.

## FITTING THE SUPPORT CAP

- Place the support cap over the upper housing half and engage the locating dowels at the joint.
- Using a nylon mallet, gently tap the support cap down to close the gap at the joints.
- Fit the bolts and tighten just enough to hold the support joints closed.



## FINAL FITTING OF THE HOUSING

- Charge the bottom and upper housing halves with the correct amount of grease. Refer to page 35 for correct types and quantities of grease depending on the application and the speed.
- Lightly oil the spherical diameter of both housing and support and slide the bottom housing half into the support base.
- Lower the shaft with the assembled inner races and cages, until the rollers touch the tracks in the bottom half housing. Make sure that when the rollers in the retained bearing enter the outer race groove they do not damage the lips.
- Turning the shaft by hand, the rollers should move freely between the thrust shoulders of the inner race and the lips of the retained outer race.



- At this point, and only if it is safe to do so, the shaft should be run at low speed and if possible, with low loading. This will allow the spherical locating surfaces to correctly align. If running the shaft under power is not an option, the shaft should be rotated by hand to achieve this goal.
- Tighten the cap bolts fully using a torque wrench. At this point the support base bolts should also be checked and tightened as required. Torque values for support screws are given in the tables on pages 40-42.

# SCREW SIZES, KEY SIZES AND TORQUE VALUES LIGHT SERIES

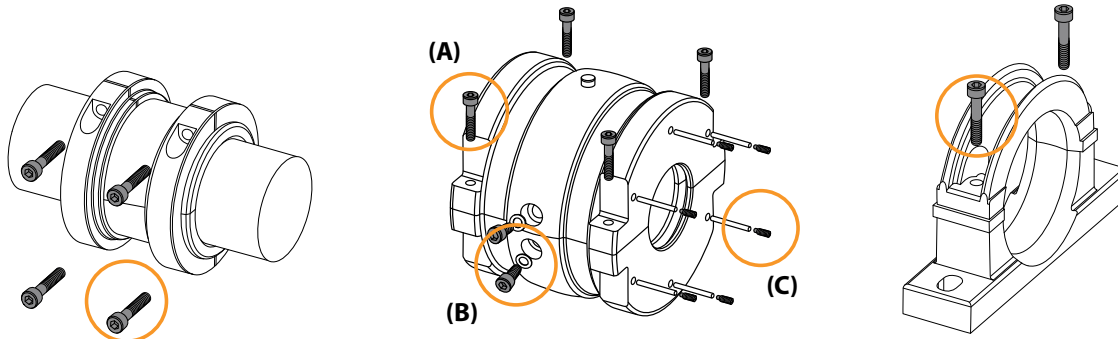

TABLE 26. LIGHT SERIES

| Shaft (d) |                | Clamping Ring <sup>(1)</sup> |     |     |       | Housing   |     |      |       |                     |     |    |       |               |     |     |       | Support |     |      |       |
|-----------|----------------|------------------------------|-----|-----|-------|-----------|-----|------|-------|---------------------|-----|----|-------|---------------|-----|-----|-------|---------|-----|------|-------|
|           |                |                              |     |     |       | Joint (A) |     |      |       | Radial Retainer (B) |     |    |       | (HR only) (C) |     |     |       |         |     |      |       |
| mm        | in.            | Screw                        | Key | Nm  | lb.ft | Screw     | Key | Nm   | lb.ft | Screw               | Key | Nm | lb.ft | Screw         | Key | Nm  | lb.ft | Screw   | Key | Nm   | lb.ft |
| 35 - 40   | 1 3/16 - 1 1/2 | M4                           | 3   | 4.5 | 3.3   | M4        | 3   | 3.5  | 2.6   | -                   | -   | -  | -     | M4            | 2   | 2   | 1.5   | M8      | 6   | 26   | 19.2  |
| 45 - 50   | 1 11/16 - 2    | M4                           | 3   | 4.5 | 3.3   | M4        | 3   | 3.5  | 2.6   | -                   | -   | -  | -     | M4            | 2   | 2   | 1.5   | M8      | 6   | 26   | 19.2  |
| 60 - 65   | 2 3/16 - 2 1/2 | M4                           | 3   | 4.5 | 3.3   | M4        | 3   | 3.5  | 2.6   | -                   | -   | -  | -     | M4            | 2   | 2   | 1.5   | M10     | 8   | 52.5 | 38.7  |
| 70 - 75   | 2 11/16 - 3    | M4                           | 3   | 4.5 | 3.3   | M4        | 3   | 3.5  | 2.6   | -                   | -   | -  | -     | M4            | 2   | 2   | 1.5   | M12     | 10  | 90   | 66.4  |
| 80 - 90   | 3 3/16 - 3 1/2 | M5                           | 4   | 8.5 | 6.3   | M5        | 4   | 6.5  | 4.8   | -                   | -   | -  | -     | M4            | 2   | 2   | 1.5   | M16     | 14  | 225  | 166.0 |
| 100 - 105 | 3 11/16 - 4    | M6                           | 5   | 15  | 11.1  | M6        | 5   | 11   | 8.1   | -                   | -   | -  | -     | M4            | 2   | 2   | 1.5   | M16     | 14  | 225  | 166.0 |
| 110 - 115 | 4 3/16 - 4 1/2 | M6                           | 5   | 15  | 11.1  | M6        | 5   | 11   | 8.1   | -                   | -   | -  | -     | M6            | 3   | 7.8 | 5.8   | M20     | 17  | 420  | 309.8 |
| 120 - 130 | 4 11/16 - 5    | M6                           | 5   | 15  | 11.1  | M6        | 5   | 11   | 8.1   | -                   | -   | -  | -     | M6            | 3   | 7.8 | 5.8   | M20     | 17  | 420  | 309.8 |
| 135 - 140 | 5 3/16 - 5 1/2 | M8                           | 6   | 35  | 25.8  | M8        | 6   | 26   | 19.2  | -                   | -   | -  | -     | M6            | 3   | 7.8 | 5.8   | M20     | 17  | 420  | 309.8 |
| 150 - 155 | 5 11/16 - 6    | M8                           | 6   | 35  | 25.8  | M8        | 6   | 26   | 19.2  | -                   | -   | -  | -     | M6            | 3   | 7.8 | 5.8   | M20     | 17  | 420  | 309.8 |
| 160       | 6 7/16 - 6 1/2 | M8                           | 6   | 35  | 25.8  | M8        | 6   | 26   | 19.2  | -                   | -   | -  | -     | M6            | 3   | 7.8 | 5.8   | M20     | 17  | 420  | 309.8 |
| 170 - 180 | 6 11/16 - 7    | M8                           | 6   | 35  | 25.8  | M8        | 6   | 26   | 19.2  | -                   | -   | -  | -     | M6            | 3   | 7.8 | 5.8   | M16     | 14  | 225  | 166.0 |
| 190 - 200 | 7 1/4 - 8      | M8                           | 6   | 35  | 25.8  | M8        | 6   | 26   | 19.2  | M10                 | 8   | 35 | 25.8  | M6            | 3   | 7.8 | 5.8   | M16     | 14  | 225  | 166.0 |
| 220 - 230 | 8 1/2 - 9      | M10                          | 8   | 70  | 51.6  | M10       | 8   | 52.5 | 38.7  | M10                 | 8   | 35 | 25.8  | M6            | 3   | 7.8 | 5.8   | M16     | 14  | 225  | 166.0 |
| 240 - 250 | 9 1/2 - 10     | M10                          | 8   | 70  | 51.6  | M10       | 8   | 52.5 | 38.7  | M10                 | 8   | 35 | 25.8  | M10           | 5   | 30  | 22.1  | M20     | 17  | 420  | 309.8 |
| 260 - 280 | 10 1/2 - 11    | M10                          | 8   | 70  | 51.6  | M10       | 8   | 52.5 | 38.7  | M10                 | 8   | 35 | 25.8  | M10           | 5   | 30  | 22.1  | M20     | 17  | 420  | 309.8 |
| 300 - 305 | 11 1/2 - 12    | M10                          | 8   | 70  | 51.6  | M10       | 8   | 52.5 | 38.7  | M10                 | 8   | 35 | 25.8  | M10           | 5   | 30  | 22.1  | M20     | 17  | 420  | 309.8 |
| 320 - 330 | 12 1/2 - 13    | M12                          | 10  | 120 | 88.5  | M12       | 10  | 90   | 66.4  | M10                 | 8   | 35 | 25.8  | M10           | 5   | 30  | 22.1  | M20     | 17  | 420  | 309.8 |
| 340 - 350 | 14             | M12                          | 10  | 120 | 88.5  | M12       | 10  | 90   | 66.4  | M10                 | 8   | 35 | 25.8  | M10           | 5   | 30  | 22.1  | M20     | 17  | 420  | 309.8 |
| 360 - 380 | 15             | M12                          | 10  | 120 | 88.5  | M12       | 10  | 90   | 66.4  | M10                 | 8   | 35 | 25.8  | M10           | 5   | 30  | 22.1  | M20     | 17  | 420  | 309.8 |
| 400       | 16             | M12                          | 10  | 120 | 88.5  | M12       | 10  | 90   | 66.4  | M10                 | 8   | 35 | 25.8  | M10           | 5   | 30  | 22.1  | M20     | 17  | 420  | 309.8 |
| 420       | 17             | M12                          | 10  | 120 | 88.5  | M12       | 10  | 90   | 66.4  | M12                 | 10  | 60 | 44.3  | M10           | 5   | 30  | 22.1  | M20     | 17  | 420  | 309.8 |
| 440 - 460 | 18             | M12                          | 10  | 120 | 88.5  | M12       | 10  | 90   | 66.4  | M12                 | 10  | 60 | 44.3  | M10           | 5   | 30  | 22.1  | M20     | 17  | 420  | 309.8 |
| 480       | 19             | M12                          | 10  | 120 | 88.5  | M12       | 10  | 90   | 66.4  | M12                 | 10  | 60 | 44.3  | M10           | 5   | 30  | 22.1  | M20     | 17  | 420  | 309.8 |
| 500       | 20             | M16                          | 14  | 300 | 221.3 | M16       | 14  | 225  | 166.0 | M12                 | 10  | 60 | 44.3  | M10           | 5   | 30  | 22.1  | M20     | 17  | 420  | 309.8 |
| 530       | 21             | M16                          | 14  | 300 | 221.3 | M16       | 14  | 225  | 166.0 | M12                 | 10  | 60 | 44.3  | M10           | 5   | 30  | 22.1  | M20     | 17  | 420  | 309.8 |
| 560       | 22             | M16                          | 14  | 300 | 221.3 | M16       | 14  | 225  | 166.0 | M12                 | 10  | 60 | 44.3  | M10           | 5   | 30  | 22.1  | M20     | 17  | 420  | 309.8 |
| 580       | 23             | M16                          | 14  | 300 | 221.3 | M16       | 14  | 225  | 166.0 | M12                 | 10  | 60 | 44.3  | M10           | 5   | 30  | 22.1  | M20     | 17  | 420  | 309.8 |
| 600       | 24             | M16                          | 14  | 300 | 221.3 | M16       | 14  | 225  | 166.0 | M12                 | 10  | 60 | 44.3  | M10           | 5   | 30  | 22.1  | M20     | 17  | 420  | 309.8 |

<sup>(1)</sup> May be increased by up to 20 percent for high axial load applications.

MEDIUM SERIES

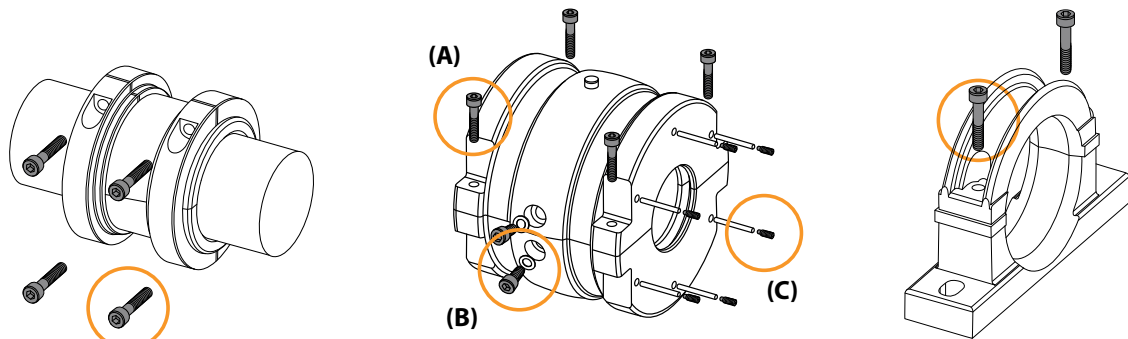
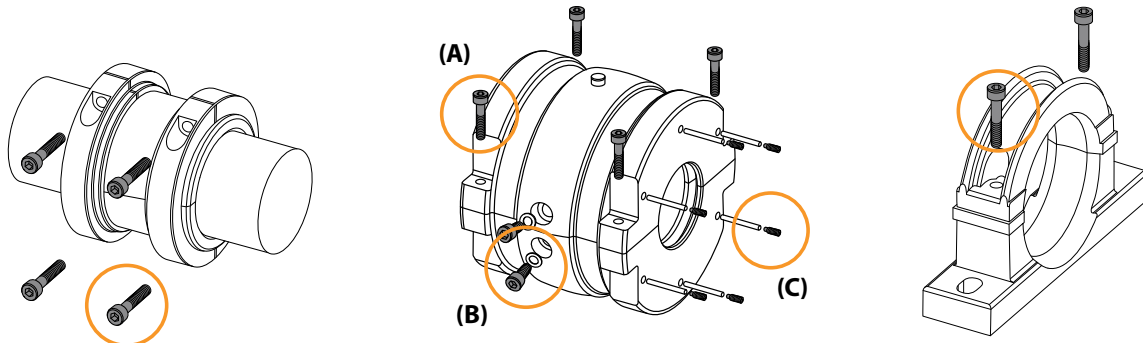

TABLE 27. MEDIUM SERIES

| Shaft (d) |                | Clamping Ring <sup>(1)</sup> |     |     |       | Housing   |     |      |       |                     |     |    |       |               |     |     |       | Support |     |      |       |
|-----------|----------------|------------------------------|-----|-----|-------|-----------|-----|------|-------|---------------------|-----|----|-------|---------------|-----|-----|-------|---------|-----|------|-------|
|           |                |                              |     |     |       | Joint (A) |     |      |       | Radial Retainer (B) |     |    |       | (HR only) (C) |     |     |       |         |     |      |       |
| mm        | in.            | Screw                        | Key | Nm  | lb.ft | Screw     | Key | Nm   | lb.ft | Screw               | Key | Nm | lb.ft | Screw         | Key | Nm  | lb.ft | Screw   | Key | Nm   | lb.ft |
| 45 - 50   | 1 11/16 - 2    | M5                           | 4   | 8.5 | 6.3   | M5        | 4   | 6.5  | 4.8   | -                   | -   | -  | -     | M4            | 2   | 2   | 1.5   | M10     | 8   | 52.5 | 38.7  |
| 60 - 65   | 2 3/16 - 2 1/2 | M5                           | 4   | 8.5 | 6.3   | M5        | 4   | 6.5  | 4.8   | -                   | -   | -  | -     | M4            | 2   | 2   | 1.5   | M12     | 10  | 90   | 66.4  |
| 70 - 75   | 2 11/16 - 3    | M6                           | 5   | 15  | 11.1  | M6        | 5   | 11   | 8.1   | -                   | -   | -  | -     | M4            | 2   | 2   | 1.5   | M16     | 14  | 225  | 166.0 |
| 80 - 90   | 3 3/16 - 3 1/2 | M6                           | 5   | 15  | 11.1  | M6        | 5   | 11   | 8.1   | -                   | -   | -  | -     | M4            | 2   | 2   | 1.5   | M16     | 14  | 225  | 166.0 |
| 100 - 105 | 3 11/16 - 4    | M6                           | 5   | 15  | 11.1  | M6        | 5   | 11   | 8.1   | -                   | -   | -  | -     | M4            | 2   | 2   | 1.5   | M20     | 17  | 420  | 309.8 |
| 110 - 115 | 4 3/16 - 4 1/2 | M8                           | 6   | 35  | 25.8  | M8        | 6   | 26   | 19.2  | -                   | -   | -  | -     | M6            | 3   | 7.8 | 5.8   | M20     | 17  | 420  | 309.8 |
| 120 - 130 | 4 11/16 - 5    | M8                           | 6   | 35  | 25.8  | M8        | 6   | 26   | 19.2  | -                   | -   | -  | -     | M6            | 3   | 7.8 | 5.8   | M20     | 17  | 420  | 309.8 |
| 135 - 140 | 5 3/16 - 5 1/2 | M8                           | 6   | 35  | 25.8  | M8        | 6   | 26   | 19.2  | -                   | -   | -  | -     | M6            | 3   | 7.8 | 5.8   | M24     | 19  | 712  | 525.1 |
| 150 - 155 | 5 11/16 - 6    | M8                           | 6   | 35  | 25.8  | M8        | 6   | 26   | 19.2  | -                   | -   | -  | -     | M6            | 3   | 7.8 | 5.8   | M24     | 19  | 712  | 525.1 |
| 160 - 170 | 6 7/16 - 6 1/2 | M10                          | 8   | 70  | 51.6  | M10       | 8   | 52.5 | 38.7  | -                   | -   | -  | -     | M6            | 3   | 7.8 | 5.8   | M20     | 17  | 420  | 309.8 |
| 180       | 6 11/16 - 7    | M10                          | 8   | 70  | 51.6  | M10       | 8   | 52.5 | 38.7  | M10                 | 8   | 35 | 25.8  | M6            | 3   | 7.8 | 5.8   | M20     | 17  | 420  | 309.8 |
| 190 - 200 | 7 1/4 - 8      | M12                          | 10  | 120 | 88.5  | M12       | 10  | 90   | 66.4  | M10                 | 8   | 35 | 25.8  | M6            | 3   | 7.8 | 5.8   | M20     | 17  | 420  | 309.8 |
| 220 - 230 | 8 1/2 - 9      | M12                          | 10  | 120 | 88.5  | M12       | 10  | 90   | 66.4  | M10                 | 8   | 35 | 25.8  | M6            | 3   | 7.8 | 5.8   | M20     | 17  | 420  | 309.8 |
| 240 - 260 | 9 1/2 - 10     | M12                          | 10  | 120 | 88.5  | M12       | 10  | 90   | 66.4  | M10                 | 8   | 35 | 25.8  | M10           | 5   | 30  | 22.1  | M20     | 17  | 420  | 309.8 |
| 270 - 280 | 10 1/2 - 11    | M16                          | 14  | 300 | 221.3 | M16       | 14  | 225  | 166.0 | M10                 | 8   | 35 | 25.8  | M10           | 5   | 30  | 22.1  | M20     | 17  | 420  | 309.8 |
| 300 - 305 | 11 1/2 - 12    | M16                          | 14  | 300 | 221.3 | M16       | 14  | 225  | 166.0 | M10                 | 8   | 35 | 25.8  | M10           | 5   | 30  | 22.1  | M20     | 17  | 420  | 309.8 |
| 320 - 330 | 12 1/2 - 13    | M16                          | 14  | 300 | 221.3 | M16       | 14  | 225  | 166.0 | M10                 | 8   | 35 | 25.8  | M10           | 5   | 30  | 22.1  | M20     | 17  | 420  | 309.8 |
| 340 - 360 | 14             | M16                          | 14  | 300 | 221.3 | M16       | 14  | 225  | 166.0 | M12                 | 10  | 60 | 44.3  | M10           | 5   | 30  | 22.1  | M20     | 17  | 420  | 309.8 |
| 380       | 15             | M16                          | 14  | 300 | 221.3 | M16       | 14  | 225  | 166.0 | M12                 | 10  | 60 | 44.3  | M10           | 5   | 30  | 22.1  | M20     | 17  | 420  | 309.8 |
| 400       | 16             | M16                          | 14  | 300 | 221.3 | M16       | 14  | 225  | 166.0 | M12                 | 10  | 60 | 44.3  | M10           | 5   | 30  | 22.1  | M24     | 19  | 712  | 525.1 |
| 420       | 17             | M16                          | 14  | 300 | 221.3 | M16       | 14  | 225  | 166.0 | M12                 | 10  | 60 | 44.3  | M10           | 5   | 30  | 22.1  | M20     | 17  | 420  | 309.8 |
| 440 - 460 | 18             | M16                          | 14  | 300 | 221.3 | M16       | 14  | 225  | 166.0 | M12                 | 10  | 60 | 44.3  | M10           | 5   | 30  | 22.1  | M20     | 17  | 420  | 309.8 |
| 480       | 19             | M20                          | 17  | 560 | 413.0 | M20       | 17  | 420  | 309.8 | M12                 | 10  | 60 | 44.3  | M10           | 5   | 30  | 22.1  | M24     | 19  | 712  | 525.1 |
| 500       | 20             | M20                          | 17  | 560 | 413.0 | M20       | 17  | 420  | 309.8 | M12                 | 10  | 60 | 44.3  | M10           | 5   | 30  | 22.1  | M24     | 19  | 712  | 525.1 |
| 530       | 21             | M20                          | 17  | 560 | 413.0 | M20       | 17  | 420  | 309.8 | M12                 | 10  | 60 | 44.3  | M10           | 5   | 30  | 22.1  | M24     | 19  | 712  | 525.1 |
| 560       | 22             | M20                          | 17  | 560 | 413.0 | M20       | 17  | 420  | 309.8 | M12                 | 10  | 60 | 44.3  | M10           | 5   | 30  | 22.1  | M24     | 19  | 712  | 525.1 |
| 580       | 23             | M20                          | 17  | 560 | 413.0 | M20       | 17  | 420  | 309.8 | M12                 | 10  | 60 | 44.3  | M10           | 5   | 30  | 22.1  | M24     | 19  | 712  | 525.1 |
| 600       | 24             | M20                          | 17  | 560 | 413.0 | M20       | 17  | 420  | 309.8 | M12                 | 10  | 60 | 44.3  | M10           | 5   | 30  | 22.1  | M24     | 19  | 712  | 525.1 |

<sup>(1)</sup> May be increased by up to 20 percent for high axial load applications.

**SCREW SIZES, KEY SIZES AND TORQUE VALUES - CONT'D**  
**HEAVY SERIES**



**TABLE 28. HEAVY SERIES**

| Shaft (d) |                  | Clamping Ring <sup>(1)</sup> |     |        |       | Housing   |       |       |       |                     |       |       |      |               |       |     |       | Support |     |        |       |
|-----------|------------------|------------------------------|-----|--------|-------|-----------|-------|-------|-------|---------------------|-------|-------|------|---------------|-------|-----|-------|---------|-----|--------|-------|
|           |                  | Screw                        | Key | Torque |       | Joint (A) |       |       |       | Radial Retainer (B) |       |       |      | (HR only) (C) |       |     |       | Screw   | Key | Torque |       |
| Nm        | lb.ft            |                              |     | Screw  | Key   | Nm        | lb.ft | Screw | Key   | Nm                  | lb.ft | Screw | Key  | Nm            | lb.ft | Nm  | lb.ft |         |     |        |       |
| 100 - 105 | 3 11/16 - 4      | M10                          | 8   | 70     | 51.6  | M10       | 8     | 52.5  | 38.7  | M10                 | 8     | 35    | 25.8 | M6            | 3     | 7.8 | 5.8   | M16     | 14  | 225    | 166.0 |
| 110 - 120 | 4 3/16 - 4 1/2   | M10                          | 8   | 70     | 51.6  | M10       | 8     | 52.5  | 38.7  | M10                 | 8     | 35    | 25.8 | M6            | 3     | 7.8 | 5.8   | M16     | 14  | 225    | 166.0 |
| 125 - 130 | 4 15/16 - 5      | M10                          | 8   | 70     | 51.6  | M10       | 8     | 52.5  | 38.7  | M10                 | 8     | 35    | 25.8 | M10           | 5     | 30  | 22.1  | M16     | 14  | 225    | 166.0 |
| 135 - 140 | 5 3/16 - 5 1/2   | M10                          | 8   | 70     | 51.6  | M10       | 8     | 52.5  | 38.7  | M10                 | 8     | 35    | 25.8 | M10           | 5     | 30  | 22.1  | M20     | 17  | 420    | 309.8 |
| 150 - 155 | 5 11/16 - 6      | M10                          | 8   | 70     | 51.6  | M10       | 8     | 52.5  | 38.7  | M10                 | 8     | 35    | 25.8 | M10           | 5     | 30  | 22.1  | M20     | 17  | 420    | 309.8 |
| 160 - 170 | 6 7/16 - 6 11/16 | M12                          | 10  | 120    | 88.5  | M12       | 10    | 90    | 66.4  | M12                 | 10    | 60    | 44.3 | M10           | 5     | 30  | 22.1  | M20     | 17  | 420    | 309.8 |
| 175 - 180 | 6 3/4 - 7        | M12                          | 10  | 120    | 88.5  | M12       | 10    | 90    | 66.4  | M12                 | 10    | 60    | 44.3 | M10           | 5     | 30  | 22.1  | M20     | 17  | 420    | 309.8 |
| 190 - 200 | 7 1/4 - 8        | M12                          | 10  | 120    | 88.5  | M12       | 10    | 90    | 66.4  | M12                 | 10    | 60    | 44.3 | M10           | 5     | 30  | 22.1  | M24     | 19  | 712    | 525.1 |
| 220 - 230 | 8 1/2 - 9        | M16                          | 14  | 300    | 221.3 | M16       | 14    | 225   | 166.0 | M12                 | 10    | 60    | 44.3 | M10           | 5     | 30  | 22.1  | M20     | 17  | 420    | 309.8 |
| 240 - 260 | 9 1/2 - 10       | M16                          | 14  | 300    | 221.3 | M16       | 14    | 225   | 166.0 | M12                 | 10    | 60    | 44.3 | M10           | 5     | 30  | 22.1  | M20     | 17  | 420    | 309.8 |
| 280       | 11               | M20                          | 17  | 560    | 413.0 | M20       | 17    | 420   | 309.8 | M12                 | 10    | 60    | 44.3 | M10           | 5     | 30  | 22.1  | M20     | 17  | 420    | 309.8 |
| 300       | 12               | M20                          | 17  | 560    | 413.0 | M20       | 17    | 420   | 309.8 | M12                 | 10    | 60    | 44.3 | M10           | 5     | 30  | 22.1  | M20     | 17  | 420    | 309.8 |
| 320 - 330 | 13               | M20                          | 17  | 560    | 413.0 | M20       | 17    | 420   | 309.8 | M12                 | 10    | 60    | 44.3 | M10           | 5     | 30  | 22.1  | M24     | 19  | 712    | 525.1 |
| 340 - 360 | 14               | M24                          | 19  | 950    | 700.7 | M20       | 17    | 420   | 309.8 | M12                 | 10    | 60    | 44.3 | M16           | 14    | 125 | 92.2  | M24     | 19  | 712    | 525.1 |
| 380 - 400 | 15 - 16          | M24                          | 19  | 950    | 700.7 | M20       | 17    | 420   | 309.8 | M12                 | 10    | 60    | 44.3 | M10           | 5     | 30  | 22.1  | M24     | 19  | 712    | 525.1 |
| 420 - 440 | 17               | M24                          | 19  | 950    | 700.7 | M20       | 17    | 420   | 309.8 | M12                 | 10    | 60    | 44.3 | M16           | 14    | 125 | 92.2  | M24     | 19  | 712    | 525.1 |
| 460       | 18               | M24                          | 19  | 950    | 700.7 | M20       | 17    | 420   | 309.8 | M12                 | 10    | 60    | 44.3 | M16           | 14    | 125 | 92.2  | M24     | 19  | 712    | 525.1 |
| 500 - 530 | 20 - 21          | M24                          | 19  | 950    | 700.7 | M20       | 17    | 420   | 309.8 | M16                 | 14    | 60    | 44.3 | M16           | 14    | 125 | 92.2  | M24     | 19  | 712    | 525.1 |
| 560       | 22               | M24                          | 19  | 950    | 700.7 | M20       | 17    | 420   | 309.8 | M12                 | 10    | 60    | 44.3 | M16           | 14    | 125 | 92.2  | M24     | 19  | 712    | 525.1 |
| 580 - 600 | 23 - 24          | M24                          | 19  | 950    | 700.7 | M20       | 17    | 420   | 309.8 | M12                 | 10    | 60    | 44.3 | M16           | 14    | 125 | 92.2  | M24     | 19  | 712    | 525.1 |

<sup>(1)</sup> May be increased by up to 20 percent for high axial load applications.

# SHIPPING WEIGHTS

TABLE 29. LIGHT SERIES

TABLE 30. MEDIUM SERIES

TABLE 31. HEAVY SERIES

|     |         | Bearing | Housing | Support | Comp. Unit |     |         | Bearing | Housing | Support | Comp. Unit |     |         | Bearing | Housing | Support | Comp. Unit |
|-----|---------|---------|---------|---------|------------|-----|---------|---------|---------|---------|------------|-----|---------|---------|---------|---------|------------|
| mm  | in.     | Kg lb.  | Kg lb.  | Kg lb.  | Kg lb.     | mm  | in.     | Kg lb.  | Kg lb.  | Kg lb.  | Kg lb.     | mm  | in.     | Kg lb.  | Kg lb.  | Kg lb.  | Kg lb.     |
| 35  | 1 3/16  | 1.3     | 2.5     | 3       | 6.8        | -   | -       | -       | -       | -       | -          | -   | -       | -       | -       | -       | -          |
| 40  | 1 1/2   | 3       | 6       | 7       | 16         | -   | -       | -       | -       | -       | -          | -   | -       | -       | -       | -       | -          |
| 45  | 1 11/16 | 1.8     | 3.5     | 5       | 10.3       | 45  | 1 11/16 | 2.5     | 5       | 5.9     | 13.4       | -   | -       | -       | -       | -       | -          |
| 50  | 2       | 4       | 8       | 11      | 23         | 50  | 2       | 6       | 11      | 13      | 30         | -   | -       | -       | -       | -       | -          |
| 60  | 2 3/16  | 2.3     | 4.4     | 5.9     | 12.6       | 60  | 2 3/16  | 3.7     | 8       | 9.5     | 21.2       | -   | -       | -       | -       | -       | -          |
| 65  | 2 1/2   | 5       | 10      | 13      | 28         | 65  | 2 1/2   | 8       | 18      | 21      | 47         | -   | -       | -       | -       | -       | -          |
| 70  | 2 11/16 | 3.3     | 6.5     | 9.5     | 19.3       | 70  | 2 11/16 | 5.6     | 10      | 15      | 30.6       | -   | -       | -       | -       | -       | -          |
| 75  | 3       | 7       | 14      | 21      | 42         | 75  | 3       | 12      | 22      | 33      | 67         | -   | -       | -       | -       | -       | -          |
| 80  | 3 3/16  | 5       | 9       | 15      | 29         | 80  | 3 3/16  | 7       | 12      | 16      | 35         | -   | -       | -       | -       | -       | -          |
| 90  | 3 1/2   | 11      | 20      | 33      | 64         | 90  | 3 1/2   | 15      | 26      | 35      | 76         | -   | -       | -       | -       | -       | -          |
| 100 | 3 11/16 | 7       | 11      | 16      | 34         | 100 | 3 11/16 | 11      | 13      | 24      | 48         | 100 | 3 11/16 | 35      | 40      | 121     | 196        |
| 105 | 4       | 15      | 24      | 35      | 74         | 105 | 4       | 24      | 29      | 53      | 106        | 105 | 4       | 77      | 88      | 266     | 431        |
| 110 | 4 3/16  | 10.5    | 16      | 24      | 50.5       | 110 | 4 3/16  | 15.5    | 20      | 41      | 76.5       | 110 | 4 3/16  | 41      | 45      | 141     | 227        |
| 115 | 4 1/2   | 23      | 35      | 53      | 111        | 115 | 4 1/2   | 34      | 44      | 90      | 168        | 115 | 4 1/2   | 90      | 90      | 310     | 499        |
| 120 | 4 11/16 | 14      | 24      | 41      | 79         | 120 | 4 11/16 | 21      | 28      | 49      | 98         | 125 | 4 11/16 | 42      | 46      | 156     | 244        |
| 130 | 5       | 31      | 53      | 90      | 174        | 130 | 5       | 46      | 62      | 108     | 216        | 130 | 5       | 92      | 101     | 343     | 536        |
| 135 | 5 3/16  | 17      | 27      | 49      | 93         | 135 | 5 3/16  | 25      | 36      | 72      | 133        | 135 | 5 3/16  | 50      | 51      | 197     | 298        |
| 140 | 5 1/2   | 37      | 59      | 108     | 204        | 140 | 5 1/2   | 55      | 79      | 158     | 292        | 140 | 5 1/2   | 110     | 112     | 433     | 655        |
| 150 | 5 11/16 | 18      | 31      | 49      | 98         | 150 | 5 11/16 | 31      | 42      | 80      | 153        | 150 | 5 11/16 | 59      | 75      | 261     | 395        |
| 155 | 6       | 40      | 68      | 108     | 216        | 155 | 6       | 68      | 92      | 176     | 336        | 155 | 6       | 130     | 165     | 574     | 869        |
| 160 | 6 7/16  | 19      | 35      | 65      | 119        | 160 | 6 7/16  | 40      | 58      | 118     | 216        | 160 | 6 7/16  | 74      | 87      | 291     | 452        |
| 170 | 6 1/2   | 42      | 77      | 143     | 262        | 170 | 6 1/2   | 88      | 128     | 260     | 476        | 170 | 6 1/2   | 163     | 191     | 640     | 994        |
| 175 | 6 11/16 | 23      | 36      | 73      | 132        | 180 | 6 11/16 | 47      | 68      | 138     | 253        | 175 | 6 11/16 | 83      | 91      | 338     | 512        |
| 180 | 7       | 51      | 79      | 161     | 291        | 180 | 7       | 103     | 150     | 304     | 557        | 180 | 7       | 183     | 200     | 744     | 1127       |
| 190 | 7 1/4   | 26      | 45      | 92      | 163        | 190 | 7 1/4   | 59      | 86      | 192     | 337        | 190 | 7 1/4   | 105     | 120     | 454     | 679        |
| 200 | 8       | 57      | 99      | 202     | 358        | 200 | 8       | 130     | 189     | 422     | 741        | 200 | 8       | 231     | 264     | 999     | 1494       |
| 220 | 8 1/2   | 33      | 48      | 117     | 198        | 220 | 8 1/2   | 69      | 101     | 229     | 399        | 220 | 8 1/2   | 151     | 164     | 408     | 949        |
| 230 | 9       | 73      | 106     | 257     | 436        | 230 | 9       | 152     | 222     | 504     | 878        | 230 | 9       | 332     | 361     | 1395    | 2088       |
| 240 | 9 1/2   | 42      | 60      | 147     | 249        | 240 | 9 1/2   | 79      | 108     | 277     | 464        | 240 | 9 1/2   | 153     | 174     | 540     | 1064       |
| 250 | 10      | 92      | 132     | 323     | 547        | 260 | 10      | 174     | 238     | 609     | 1021       | 260 | 10      | 337     | 383     | 1621    | 2341       |
| 260 | 10 1/2  | 53      | 73      | 171     | 297        | 270 | 10 1/2  | 87      | 134     | 320     | 541        | 280 | 11      | 203     | 201     | 459     | 863        |
| 280 | 11      | 117     | 161     | 376     | 654        | 280 | 11      | 191     | 295     | 704     | 1190       | 280 | 11      | 447     | 442     | 1010    | 1899       |
| 300 | 11 1/2  | 60      | 89      | 199     | 348        | 300 | 11 1/2  | 125     | 132     | 372     | 629        | 300 | 12      | 242     | 249     | 1019    | 1510       |
| 305 | 12      | 132     | 196     | 438     | 766        | 305 | 12      | 275     | 290     | 818     | 1383       | 305 | 12      | 532     | 548     | 2242    | 3322       |
| 320 | 12 1/2  | 72      | 109     | 214     | 395        | 320 | 12 1/2  | 150     | 176     | 385     | 711        | 320 | 13      | 327     | 300     | 1116    | 1743       |
| 330 | 13      | 158     | 240     | 471     | 869        | 330 | 13      | 330     | 387     | 847     | 1564       | 320 | 13      | 719     | 660     | 2455    | 3834       |
| 340 | 14      | 79      | 121     | 241     | 441        | 340 | 14      | 184     | 190     | 477     | 851        | 340 | 14      | 375     | 361     | 1620    | 2356       |
| 350 | 14      | 174     | 266     | 530     | 970        | 360 | 14      | 405     | 418     | 1049    | 1872       | 360 | 14      | 825     | 794     | 3564    | 5183       |
| 360 | 15      | 90      | 130     | 294     | 514        | 380 | 15      | 187     | 213     | 490     | 890        | 380 | 15      | 436     | 433     | 1538    | 2407       |
| 380 | 15      | 198     | 286     | 647     | 1131       | 380 | 15      | 411     | 469     | 1078    | 1958       | 400 | 16      | 959     | 953     | 3384    | 5296       |
| 400 | 16      | 96      | 145     | 315     | 556        | 400 | 16      | 210     | 258     | 540     | 1008       | -   | -       | -       | -       | -       | -          |
| 420 | 17      | 211     | 319     | 693     | 1223       | 400 | 16      | 462     | 568     | 1188    | 2218       | 420 | 17      | 400     | 443     | 1014    | 1857       |
| 440 | 18      | 105     | 155     | 323     | 583        | 420 | 17      | 245     | 269     | 586     | 1100       | 440 | 18      | 880     | 975     | 2231    | 4086       |
| 460 | 18      | 231     | 341     | 711     | 1283       | 440 | 18      | 539     | 592     | 1289    | 2420       | 460 | 18      | 636     | 274     | 1513    | 2423       |
| 480 | 19      | 119     | 156     | 377     | 652        | 480 | 19      | 255     | 270     | 623     | 1148       | 460 | 18      | 1399    | 603     | 3329    | 5331       |
| 460 | 18      | 262     | 343     | 829     | 1434       | 460 | 18      | 561     | 594     | 1371    | 2526       | -   | -       | -       | -       | -       | -          |
| 480 | 19      | 123     | 167     | 467     | 757        | 480 | 19      | 268     | 277     | 690     | 1235       | -   | -       | -       | -       | -       | -          |
| 480 | 19      | 271     | 367     | 1027    | 1665       | 480 | 19      | 590     | 609     | 1518    | 2717       | -   | -       | -       | -       | -       | -          |
| 500 | 20      | 139     | 198     | 449     | 786        | 500 | 20      | 276     | 328     | 745     | 1349       | 500 | 20      | 700     | 880     | 1863    | 3443       |
| 530 | 21      | 306     | 436     | 988     | 1730       | 500 | 20      | 607     | 722     | 1639    | 2968       | 530 | 21      | 1540    | 1936    | 4099    | 7575       |
| 530 | 21      | 180     | 220     | 502     | 902        | 530 | 21      | 314     | 357     | 899     | 1570       | -   | -       | -       | -       | -       | -          |
| 530 | 21      | 396     | 484     | 1104    | 1984       | 530 | 21      | 691     | 785     | 1978    | 3454       | -   | -       | -       | -       | -       | -          |
| 560 | 22      | 185     | 258     | 578     | 1021       | 560 | 22      | 341     | 385     | 960     | 1686       | 560 | 22      | 675     | 694     | 1847    | 3216       |
| 560 | 22      | 407     | 568     | 1272    | 2247       | 560 | 22      | 750     | 847     | 2112    | 3709       | 560 | 22      | 1485    | 1527    | 4063    | 7075       |
| 580 | 23      | 190     | 280     | 690     | 1160       | 580 | 23      | 375     | 405     | 1001    | 1781       | 580 | 23      | 700     | 770     | 1794    | 3264       |
| 580 | 23      | 418     | 616     | 1518    | 2552       | 580 | 23      | 825     | 891     | 2202    | 3918       | 600 | 24      | 1540    | 1694    | 3947    | 7181       |
| 600 | 24      | 240     | 296     | 730     | 1266       | 600 | 24      | 390     | 460     | 1056    | 1906       | -   | -       | -       | -       | -       | -          |
| 600 | 24      | 528     | 651     | 1606    | 2785       | 600 | 24      | 858     | 1012    | 2323    | 4193       | -   | -       | -       | -       | -       | -          |

# ***MOUNTED BEARING CONVERSION WORKSHEET***

**Option #1:** To help us understand your application needs, please fill out the information below. This data will enable us to select the appropriate mounted split cylindrical bearing that will perform best for your application.

**Option #2:** Please fill out the following information to help us select the appropriate mounted split cylindrical bearing for your application.

**Option #3:** When converting to a different style of mounted bearings, use this worksheet to provide the application data specific to your project needs. This information is critical to ensuring the appropriate split cylindrical bearing unit is selected.

Date: \_\_\_\_\_

Customer Contact: \_\_\_\_\_ Timken Contact: \_\_\_\_\_

Application Details: \_\_\_\_\_

***Drive Details***

Motor Power: \_\_\_\_\_ No. Belts: \_\_\_\_\_

Direct Drive:  YES  NO Drive Pulley Dia. (mm): \_\_\_\_\_

Belt Drive:  YES  NO Driven Pulley Dia. (mm): \_\_\_\_\_

Gear Drive:  YES  NO Current DE Bearing: \_\_\_\_\_

Gear Ratio:  YES  NO Current NDE Bearing: \_\_\_\_\_

***Environment***

Wet:  YES  NO Bearing Temp. (° C or ° F): \_\_\_\_\_

Dry:  YES  NO Shaft Diameter (mm): \_\_\_\_\_

Dust:  YES  NO

Severe:  YES  NO Shaft Speed (RPM): \_\_\_\_\_

Submerged:  YES  NO

| <b><i>Load</i></b>        | <b><i>Lubrication</i></b>                                        | <b><i>Specification</i></b> | <b><i>Amount</i></b> |
|---------------------------|------------------------------------------------------------------|-----------------------------|----------------------|
| Radial (kN or lbs): _____ | Oil: <input type="checkbox"/> YES <input type="checkbox"/> NO    | _____                       | _____                |
| Axial (kN or lbs): _____  | Grease: <input type="checkbox"/> YES <input type="checkbox"/> NO | _____                       | _____                |

***Duty***

Intermittent:  YES  NO

Continuous:  YES  NO

***Current Sealing Arrangement:*** \_\_\_\_\_



## **LIGHT SERIES**

Light series bearing products are by far the most commonly utilized range within the split bearing family. With a wide variety of mounting and sealing solutions available, light series bearing units can readily be matched to an ever-increasing range of applications. If a standard catalog product does not meet your requirements, a Timken engineer will be happy to provide help and advice on your application.

The following topics are covered within this section:

|                                                                                      |    |
|--------------------------------------------------------------------------------------|----|
| Light Series Bearing and Housing<br>35 mm to 155 mm (1 3/8 in. to 6 in.) . . . . .   | 46 |
| Light Series Support S01 - S10 . . . . .                                             | 47 |
| Light Series Bearing and Housing<br>160 mm to 350 mm (6 3/8 in. to 14 in.) . . . . . | 48 |
| Light Series Support S11 - S19 . . . . .                                             | 49 |
| Light Series Bearing and Housing<br>360 mm to 600 mm (15 in. to 24 in.) . . . . .    | 50 |
| Light Series Support S20 - S29 . . . . .                                             | 51 |
| Light Series Flange Units<br>35 mm - 305 mm (1 3/8 in. to 12 in.) . . . . .          | 52 |
| Light Series Take-Up Units TT/TP<br>35 mm to 155 mm (1 3/8 in. to 6 in.) . . . . .   | 54 |
| Light Series Support Hanger Units . . . . .                                          | 56 |

# LIGHT SERIES BEARING AND HOUSING

## 35 MM TO 155 MM (1 3/16 IN. TO 6 IN.)

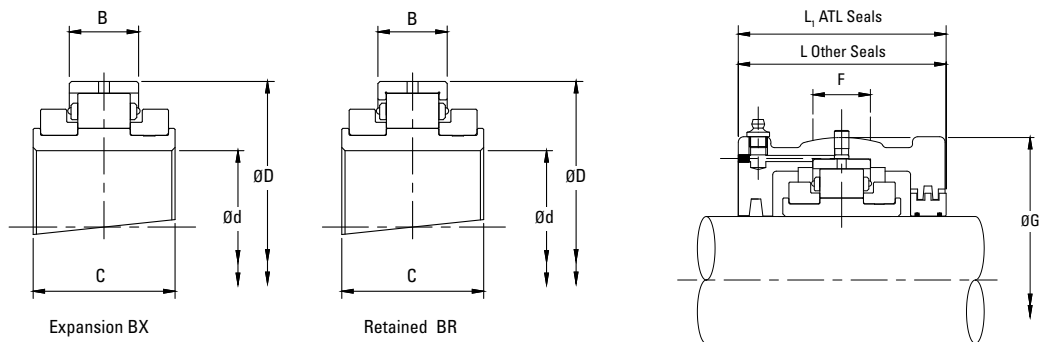

| Shaft (d)         |                                    | Reference<br>Add BR for Retained<br>Add BX for Expansion<br>e.g. LSE215BR |                                      | Bearings Ratings |               |                  |      |                  |                |                | Housing Reference                                                         |                                                                               |                                      |                  |           |            |            |
|-------------------|------------------------------------|---------------------------------------------------------------------------|--------------------------------------|------------------|---------------|------------------|------|------------------|----------------|----------------|---------------------------------------------------------------------------|-------------------------------------------------------------------------------|--------------------------------------|------------------|-----------|------------|------------|
|                   |                                    |                                                                           |                                      | Dynamic Cr       | Static Cor    | Axial Ca         | Max  | D                | B              | C              | ATL Seals<br>Add HRTL for Retained Add HXTL for Expansion<br>e.g. LS4HRTL | Other Seal Types<br>Add HR for Retained Add HX for Expansion<br>e.g. LSE215HR | G                                    | F                | L         | L1         |            |
| mm                | in.                                |                                                                           |                                      | kN lb.           | kN lb.        | kN lb.           | RPM  | mm in.           | mm in.         | mm in.         |                                                                           |                                                                               | mm in.                               | mm in.           | mm in.    | mm in.     |            |
| 35<br>40          | 1 3/16<br>1 1/4<br>1 1/16<br>1 1/2 | LSM35<br>LSM40                                                            | LSE103<br>LSE104<br>LSE107<br>LSE108 | 65<br>14613      | 68<br>15287   | 3.20<br>719.38   | 5400 | 84.14<br>3.313   | 23.80<br>0.937 | 55.00<br>2.165 | LS1                                                                       | LSM35<br>LSM40                                                                | LSE103<br>LSE104<br>LSE107<br>LSE108 | 100.00<br>3.937  | 25<br>1.0 | 84<br>3.3  | 91<br>3.6  |
| 45<br>50          | 1 11/16<br>1 3/4<br>1 15/16<br>2   | LSM45<br>LSM50                                                            | LSE111<br>LSE112<br>LSE115<br>LSE200 | 83<br>18659      | 87<br>19558   | 3.60<br>809.30   | 4630 | 98.42<br>3.875   | 25.40<br>1.000 | 60.00<br>2.362 | LS2                                                                       | LSM45<br>LSM50                                                                | LSE111<br>LSE112<br>LSE115<br>LSE200 | 117.48<br>4.625  | 25<br>1.0 | 96<br>3.8  | 98<br>3.9  |
| 55<br>60<br>65    | 2 3/16<br>2 1/4<br>2 7/16<br>2 1/2 | LSM55<br>LSM60<br>LSM65                                                   | LSE203<br>LSE204<br>LSE207<br>LSE208 | 103<br>23155     | 115<br>25853  | 5.40<br>1213.95  | 3940 | 114.30<br>4.500  | 27.00<br>1.063 | 60.00<br>2.362 | LS3                                                                       | LSM55<br>LSM60<br>LSM65                                                       | LSE203<br>LSE204<br>LSE207<br>LSE208 | 134.94<br>5.313  | 32<br>1.3 | 102<br>4.0 | 104<br>4.1 |
| 70<br>75          | 2 11/16<br>2 3/4<br>2 15/16<br>3   | LSM70<br>LSM75                                                            | LSE211<br>LSE212<br>LSE215<br>LSE300 | 138<br>31024     | 161<br>36194  | 7.60<br>1708.53  | 3310 | 133.35<br>5.250  | 31.80<br>1.252 | 65.00<br>2.559 | LS4                                                                       | LSM70<br>LSM75                                                                | LSE211<br>LSE212<br>LSE215<br>LSE300 | 157.16<br>6.187  | 38<br>1.5 | 112<br>4.4 | 114<br>4.5 |
| 80<br>85<br>90    | 3 3/16<br>3 1/4<br>3 7/16<br>3 1/2 | LSM80<br>LSM85<br>LSM90                                                   | LSE303<br>LSE304<br>LSE307<br>LSE308 | 187<br>42039     | 231<br>51931  | 12.40<br>2787.59 | 2790 | 152.4<br>6.000   | 38.90<br>1.531 | 75.00<br>2.953 | LS5                                                                       | LSM80<br>LSM85<br>LSM90                                                       | LSE303<br>LSE304<br>LSE307<br>LSE308 | 177.80<br>7.000  | 50<br>2.0 | 134<br>5.3 | 136<br>5.4 |
| 100<br>105        | 3 11/16<br>3 3/4<br>3 15/16<br>4   | LSM100<br>LSM105                                                          | LSE311<br>LSE312<br>LSE315<br>LSE400 | 288<br>64745     | 366<br>82280  | 16.00<br>3596.90 | 2340 | 174.62<br>6.875  | 45.30<br>1.783 | 85.00<br>3.346 | LS6                                                                       | LSM100<br>LSM105                                                              | LSE311<br>LSE312<br>LSE315<br>LSE400 | 203.20<br>8.000  | 50<br>2.0 | 132<br>5.2 | 134<br>5.3 |
| 110<br>115        | 4 3/16<br>4 1/4<br>4 7/16<br>4 1/2 | LSM110<br>LSM115                                                          | LSE403<br>LSE404<br>LSE407<br>LSE408 | 316<br>71040     | 427<br>95993  | 18.60<br>4181.39 | 1970 | 203.20<br>8.000  | 46.90<br>1.846 | 90.00<br>3.543 | LS7                                                                       | LSM110<br>LSM115                                                              | LSE403<br>LSE404<br>LSE407<br>LSE408 | 231.78<br>9.125  | 64<br>2.5 | 140<br>5.5 | 142<br>5.6 |
| 120<br>125<br>130 | 4 11/16<br>4 3/4<br>4 15/16<br>5   | LSM120<br>LSM125<br>LSM130                                                | LSE411<br>LSE412<br>LSE415<br>LSE500 | 363<br>81606     | 496<br>111505 | 22.20<br>4990.69 | 1740 | 222.25<br>8.750  | 54.00<br>2.126 | 95.00<br>3.740 | LS8                                                                       | LSM120<br>LSM125<br>LSM130                                                    | LSE411<br>LSE412<br>LSE415<br>LSE500 | 266.70<br>10.500 | 76<br>3.0 | 154<br>6.1 | 156<br>6.1 |
| 135<br>140        | 5 3/16<br>5 1/4<br>5 7/16<br>5 1/2 | LSM135<br>LSM140                                                          | LSE503<br>LSE504<br>LSE507<br>LSE508 | 422<br>94869     | 585<br>131513 | 25.80<br>5799.99 | 1570 | 241.30<br>9.500  | 55.60<br>2.189 | 98.40<br>3.874 | LS9                                                                       | LSM135<br>LSM140                                                              | LSE503<br>LSE504<br>LSE507<br>LSE508 | 279.40<br>11.000 | 76<br>3.0 | 166<br>6.5 | 168<br>6.6 |
| 150<br>155<br>160 | 5 11/16<br>5 3/4<br>5 15/16<br>6   | LSM150<br>LSM155<br>LSM160A                                               | LSE511<br>LSE512<br>LSE515<br>LSE600 | 459<br>103187    | 664<br>149273 | 29.40<br>6609.30 | 1450 | 254.00<br>10.000 | 55.60<br>2.189 | 98.40<br>3.874 | LS10<br>LS10E0548                                                         | LSM150<br>LSM155<br>LSM160A                                                   | LSE511<br>LSE512<br>LSE515<br>LSE600 | 295.28<br>11.625 | 82<br>3.2 | 172<br>6.8 | 174<br>6.9 |



# LIGHT SERIES SUPPORT

## S01 - S10

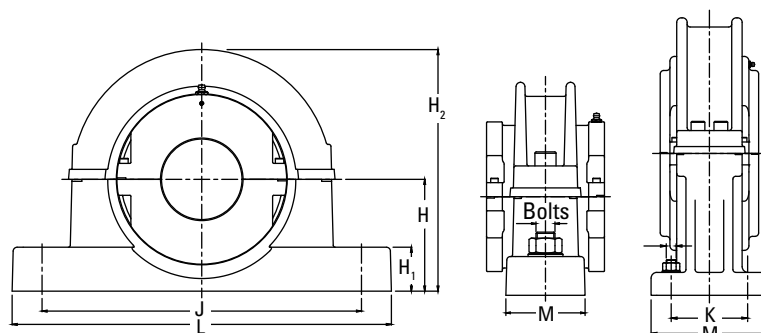

| Shaft (d)                              |                                    | Support Reference | H                                          | H <sub>1</sub>                         | H <sub>2</sub>                             | J x K                                                  | L x M                                                              | Bolts              |
|----------------------------------------|------------------------------------|-------------------|--------------------------------------------|----------------------------------------|--------------------------------------------|--------------------------------------------------------|--------------------------------------------------------------------|--------------------|
| mm                                     | in.                                |                   | mm<br>in.                                  | mm<br>in.                              | mm<br>in.                                  | mm<br>in.                                              | mm<br>in.                                                          |                    |
| <b>35</b><br><b>40</b>                 | 1 3/16<br>1 1/4<br>1 7/16<br>1 1/2 | S01               | <b>60</b><br>2.362                         | <b>22</b><br>0.9                       | <b>138</b><br>5.4                          | <b>180</b><br>7.1                                      | <b>228 x 60</b><br>9 x 2.4                                         | 2 x M12            |
| <b>45</b><br><b>50</b>                 | 1 11/16<br>1 3/4<br>1 15/16<br>2   | S02               | <b>70</b><br>2.756                         | <b>25</b><br>1.0                       | <b>158</b><br>6.2                          | <b>214</b><br>8.4                                      | <b>270 x 60</b><br>10.6 x 2.4                                      | 2 x M16            |
| <b>55</b><br><b>60</b><br><b>65</b>    | 2 3/16<br>2 1/4<br>2 7/16<br>2 1/2 | S03               | <b>80</b><br>3.150                         | <b>32</b><br>1.3                       | <b>180</b><br>7.1                          | <b>234</b><br>9.2                                      | <b>280 x 70</b><br>11 x 2.8                                        | 2 x M16            |
| <b>70</b><br><b>75</b>                 | 2 11/16<br>2 3/4<br>2 15/16<br>3   | S04               | <b>95</b><br>3.740                         | <b>38</b><br>1.5                       | <b>208</b><br>8.2                          | <b>270</b><br>10.6                                     | <b>330 x 76</b><br>13 x 3                                          | 2 x M20            |
| <b>80</b><br><b>85</b><br><b>90</b>    | 3 3/16<br>3 1/4<br>3 7/16<br>3 1/2 | S05<br>S05-4B     | <b>112</b><br>4.409<br><b>112</b><br>4.409 | <b>44</b><br>1.7<br><b>44</b><br>1.7   | <b>242</b><br>9.53<br><b>242</b><br>9.53   | <b>320</b><br>12.6<br><b>328 x 88.9</b><br>12.9 x 3.5  | <b>380 x 90</b><br>15 x 3.5<br><b>380 x 140</b><br>15 x 5.51       | 2 x M24<br>4 x M20 |
| <b>100</b><br><b>105</b>               | 3 11/16<br>3 3/4<br>3 15/16<br>4   | S06<br>S06-4B     | <b>125</b><br>4.921<br><b>125</b><br>4.921 | <b>55</b><br>2.17<br><b>55</b><br>2.17 | <b>265</b><br>10.43<br><b>265</b><br>10.43 | <b>354</b><br>13.9<br><b>368 x 102</b><br>14.5 x 4     | <b>420 x 102</b><br>16.5 x 4<br><b>426 x 152</b><br>16.8 x 6       | 2 x M24<br>4 x M20 |
| <b>110</b><br><b>115</b>               | 4 3/16<br>4 1/4<br>4 7/16<br>4 1/2 | S07<br>S07-4B     | <b>143</b><br>5.630<br><b>143</b><br>5.630 | <b>60</b><br>2.4<br><b>60</b><br>2.4   | <b>303</b><br>11.93<br><b>303</b><br>11.93 | <b>392</b><br>15.4<br><b>412 x 114.3</b><br>16.2 x 4.5 | <b>466 x 120</b><br>18.3 x 4.7<br><b>476 x 172</b><br>17.74 x 6.77 | 2 x M24<br>4 x M20 |
| <b>120</b><br><b>125</b><br><b>130</b> | 4 11/16<br>4 3/4<br>4 15/16<br>5   | S08               | <b>162</b><br>6.378                        | <b>38</b><br>1.5                       | <b>372</b><br>14.6                         | <b>450 x 120</b><br>17.7 x 4.7                         | <b>508 x 178</b><br>20 x 7                                         | 4 x M24            |
| <b>135</b><br><b>140</b>               | 5 3/16<br>5 1/4<br>5 7/16<br>5 1/2 | S09               | <b>181</b><br>7.126                        | <b>40</b><br>1.6                       | <b>405</b><br>15.9                         | <b>482 x 120</b><br>19 x 4.7                           | <b>558 x 178</b><br>22 x 7                                         | 4 x M24            |
| <b>150</b><br><b>155</b><br><b>160</b> | 5 11/16<br>5 3/4<br>5 15/16<br>6   | S10               | <b>181</b><br>7.126                        | <b>40</b><br>1.6                       | <b>415</b><br>16.3                         | <b>496 x 120</b><br>19.5 x 4.7                         | <b>558 x 178</b><br>22 x 7                                         | 4 x M24            |

# LIGHT SERIES BEARING AND HOUSING

## 160 MM TO 350 MM (6 7/16 IN. TO 14 IN.)

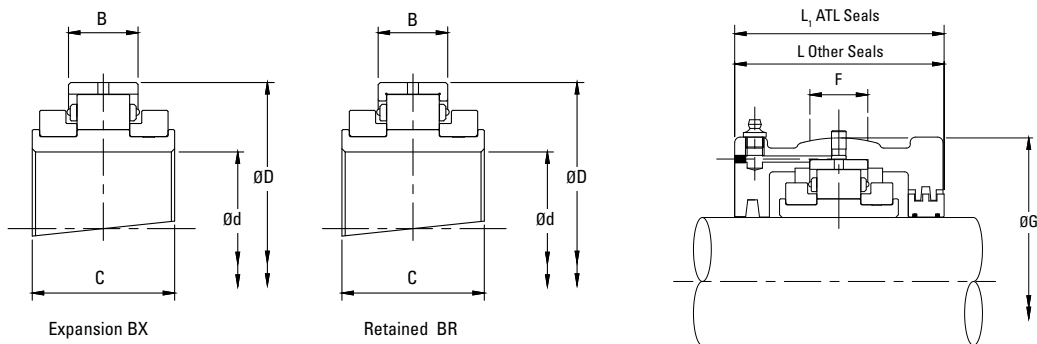

| Shaft (d)                              |                                  | Reference<br>Add <b>BR</b> for Retained<br>Add <b>BX</b> for Expansion<br>e.g. LSE715BR |                                      | Bearings Ratings          |                           |                         |      |                         |                       | Housing Reference      |                                                                                             |                            |                                                                                               |                         |                  |                    |                   |
|----------------------------------------|----------------------------------|-----------------------------------------------------------------------------------------|--------------------------------------|---------------------------|---------------------------|-------------------------|------|-------------------------|-----------------------|------------------------|---------------------------------------------------------------------------------------------|----------------------------|-----------------------------------------------------------------------------------------------|-------------------------|------------------|--------------------|-------------------|
|                                        |                                  |                                                                                         |                                      | Dynamic<br>C <sub>r</sub> | Static<br>C <sub>0r</sub> | Axial<br>C <sub>a</sub> | Max  | D                       | B                     | C                      | ATL Seals<br>Add <b>HRTL</b> for Retained<br>Add <b>HXTL</b> for Expansion<br>e.g. LS13HRTL |                            | Other Seal Types<br>Add <b>HR</b> for Retained<br>Add <b>HX</b> for Expansion<br>e.g. LS715HR |                         | G                | F                  | L                 |
| mm                                     | in.                              |                                                                                         |                                      | kN<br>lb.                 | kN<br>lb.                 | kN<br>lb.               | RPM  | mm<br>in.               | mm<br>in.             | mm<br>in.              |                                                                                             |                            | mm<br>in.                                                                                     | mm<br>in.               | mm<br>in.        | mm<br>in.          |                   |
| <b>160</b><br><b>170A</b>              | 6 7/16<br>6 1/2                  | LSM160<br>LSM170A                                                                       | LSE607<br>LSE608                     | <b>583</b><br>131064      | <b>792</b><br>178049      | <b>33.00</b><br>7419    | 1320 | <b>273.05</b><br>10.750 | <b>60.30</b><br>2.374 | <b>109.00</b><br>4.291 | LS11                                                                                        | LSM160<br>LSM170A          | LSE607<br>LSE608                                                                              | <b>311.15</b><br>12.250 | <b>76</b><br>3.0 | <b>172</b><br>6.8  | <b>192</b><br>7.6 |
| <b>170</b><br><b>175</b><br><b>180</b> | 6 11/16<br>6 3/4<br>6 15/16<br>7 | LSM170<br>LSM175<br>LSM180                                                              | LSE611<br>LSE612<br>LSE615<br>LSE700 | <b>524</b><br>117800      | <b>828</b><br>186142      | <b>36.40</b><br>8183    | 1220 | <b>285.75</b><br>11.250 | <b>55.50</b><br>2.185 | <b>109.00</b><br>4.291 | LS12                                                                                        | LSM170<br>LSM175<br>LSM180 | LSE611<br>LSE612<br>LSE615<br>LSE700                                                          | <b>323.85</b><br>12.750 | <b>70</b><br>2.8 | <b>172</b><br>6.8  | <b>200</b><br>7.9 |
| <b>190</b><br><b>200</b>               | 7 1/4<br>7 1/2<br>7 15/16<br>8   | LSM190<br>LSM200                                                                        | LSE704<br>LSE708<br>LSE715<br>LSE800 | <b>614</b><br>138033      | <b>990</b><br>222561      | <b>41.00</b><br>9217    | 1070 | <b>311.15</b><br>12.250 | <b>60.30</b><br>2.374 | <b>109.00</b><br>4.291 | LS13                                                                                        | LSM190<br>LSM200           | LSE704<br>LSE708<br>LSE715<br>LSE800                                                          | <b>358.78</b><br>14.125 | <b>86</b><br>3.4 | <b>172</b><br>6.8  | <b>200</b><br>7.9 |
| <b>220</b><br><b>230</b>               | 8 1/2<br>8 7/8<br>9              | LSM220<br>LSM230                                                                        | LSE808<br>LSE814<br>LSE900           | <b>708</b><br>159165      | <b>1168</b><br>262577     | <b>49.00</b><br>11016   | 930  | <b>342.90</b><br>13.500 | <b>63.50</b><br>2.500 | <b>115.00</b><br>4.528 | LS14                                                                                        | LSM220<br>LSM230           | LSE808<br>LSE814<br>LSE900                                                                    | <b>387.35</b><br>15.250 | <b>82</b><br>3.2 | <b>178</b><br>7.0  | <b>216</b><br>8.5 |
| <b>240</b><br><b>250</b>               | 9 1/2<br>9 3/4<br>10             | LSM240<br>LSM250                                                                        | LSE908<br>LSE912<br>LSE1000          | <b>744</b><br>167258      | <b>1289</b><br>289779     | <b>57.80</b><br>12994   | 820  | <b>374.65</b><br>14.750 | <b>66.70</b><br>2.626 | <b>122.00</b><br>4.803 | LS15                                                                                        | LSM240<br>LSM250           | LSE908<br>LSE912<br>LSE1000                                                                   | <b>419.10</b><br>16.500 | <b>90</b><br>3.5 | <b>188</b><br>7.4  | <b>222</b><br>8.7 |
| <b>260</b><br><b>270</b><br><b>280</b> | 10 1/2<br>10 3/4<br>11           | LSM260<br>LSM270<br>LSM280                                                              | LSE1008<br>LSE1012<br>LSE1100        | <b>848</b><br>190638      | <b>1502</b><br>337663     | <b>66.80</b><br>15017   | 730  | <b>406.40</b><br>16.000 | <b>69.00</b><br>2.717 | <b>128.00</b><br>5.039 | LS16                                                                                        | LSM260<br>LSM270<br>LSM280 | LSE1008<br>LSE1012<br>LSE1100                                                                 | <b>454.00</b><br>17.874 | <b>95</b><br>3.7 | <b>204</b><br>8.0  | <b>232</b><br>9.1 |
| <b>300</b><br><b>305</b>               | 11 1/2<br>12                     | LSM300<br>LSM305                                                                        | LSE1108<br>LSE1200                   | <b>929</b><br>208848      | <b>1665</b><br>374307     | <b>78.20</b><br>17580   | 650  | <b>438.15</b><br>17.250 | <b>74.60</b><br>2.937 | <b>143.00</b><br>5.630 | LS17                                                                                        | LSM300<br>LSM305           | LSE1108<br>LSE1200                                                                            | <b>489.00</b><br>19.252 | <b>98</b><br>3.9 | <b>216</b><br>8.5  | <b>248</b><br>9.8 |
| <b>320</b><br><b>330</b>               | 12 1/2<br>13                     | LSM320<br>LSM330                                                                        | LSE1208<br>LSE1300                   | <b>920</b><br>206824      | <b>1674</b><br>376330     | <b>89.00</b><br>20008   | 590  | <b>463.55</b><br>18.250 | <b>74.60</b><br>2.937 | <b>136.00</b><br>5.354 | LS18                                                                                        | LSM320<br>LSM330           | LSE1208<br>LSE1300                                                                            | <b>520.70</b><br>20.500 | <b>95</b><br>3.7 | <b>260</b><br>10.2 | —                 |
| <b>340</b><br><b>350</b>               | 14                               | LSM340<br>LSM350                                                                        | LSE1400                              | <b>1022</b><br>229755     | <b>1965</b><br>441745     | <b>99.60</b><br>22391   | 540  | <b>488.95</b><br>19.250 | <b>74.60</b><br>2.937 | <b>136.00</b><br>5.354 | LS19                                                                                        | LSM340<br>LSM350           | LSE1400                                                                                       | <b>546.10</b><br>21.500 | <b>98</b><br>3.9 | <b>260</b><br>10.2 | —                 |

For triple labyrinth seal designations, please refer to page 32-34.

# LIGHT SERIES SUPPORT

## S11 - S19

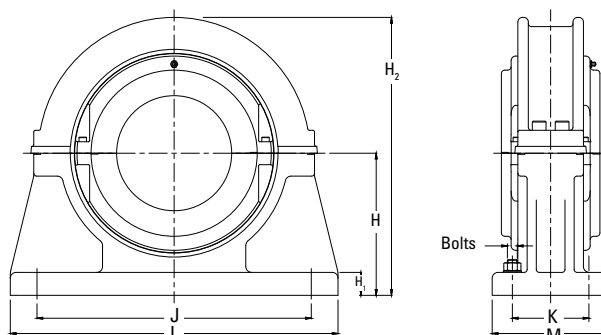

| Shaft (d)                              |                                  | Support Reference | H                    | H <sub>1</sub>   | H <sub>2</sub>     | J x K                          | L x M                         | Bolts   |
|----------------------------------------|----------------------------------|-------------------|----------------------|------------------|--------------------|--------------------------------|-------------------------------|---------|
| mm                                     | in.                              |                   | mm<br>in.            | mm<br>in.        | mm<br>in.          | mm<br>in.                      | mm<br>in.                     |         |
| <b>160</b><br><b>170A</b>              | 6 7/16<br>6 1/2                  | S11               | <b>213</b><br>8.386  | <b>32</b><br>1.3 | <b>430</b><br>16.9 | <b>368 x 114</b><br>14.5 x 4.5 | <b>508 x 178</b><br>20 x 7    | 4 x M24 |
| <b>170</b><br><b>175</b><br><b>180</b> | 6 11/16<br>6 3/4<br>6 15/16<br>7 | S12               | <b>235</b><br>9.252  | <b>35</b><br>1.4 | <b>470</b><br>18.5 | <b>388 x 128</b><br>15.3 x 5   | <b>534 x 190</b><br>21 x 7.5  | 4 x M24 |
| <b>190</b><br><b>200</b>               | 7 1/4<br>7 1/2<br>7 15/16<br>8   | S13               | <b>248</b><br>9.764  | <b>38</b><br>1.5 | <b>495</b><br>19.5 | <b>422 x 140</b><br>16.6 x 5.5 | <b>572 x 204</b><br>22.5 x 8  | 4 x M24 |
| <b>220</b><br><b>230</b>               | 8 1/2<br>8 7/8<br>9              | S14               | <b>270</b><br>10.630 | <b>40</b><br>1.6 | <b>540</b><br>21.3 | <b>460 x 140</b><br>18.1 x 5.5 | <b>636 x 216</b><br>25 x 8.5  | 4 x M30 |
| <b>240</b><br><b>250</b>               | 9 1/2<br>9 3/4<br>10             | S15               | <b>292</b><br>11.496 | <b>44</b><br>1.7 | <b>585</b><br>23.0 | <b>502 x 140</b><br>19.8 x 5.5 | <b>686 x 228</b><br>27 x 9    | 4 x M30 |
| <b>260</b><br><b>270</b><br><b>280</b> | 10 1/2<br>10 3/4<br>11           | S16               | <b>311</b><br>12.244 | <b>48</b><br>1.9 | <b>620</b><br>24.4 | <b>534 x 140</b><br>21 x 5.5   | <b>724 x 228</b><br>28.5 x 9  | 4 x M30 |
| <b>300</b><br><b>305</b>               | 11 1/2<br>12                     | S17               | <b>343</b><br>13.504 | <b>50</b><br>2.0 | <b>685</b><br>27.0 | <b>584 x 178</b><br>23 x 7     | <b>762 x 254</b><br>32 x 10   | 4 x M30 |
| <b>320</b><br><b>330</b>               | 12 1/2<br>13                     | S18               | <b>368</b><br>14.488 | <b>54</b><br>2.1 | <b>735</b><br>28.9 | <b>622 x 178</b><br>24.5 x 7   | <b>812 x 254</b><br>32 x 10   | 4 x M36 |
| <b>340</b><br><b>350</b>               | 14                               | S19               | <b>387</b><br>15.236 | <b>57</b><br>2.2 | <b>775</b><br>30.5 | <b>654 x 166</b><br>25.7 x 6.5 | <b>850 x 254</b><br>33.5 x 10 | 4 x M36 |

# LIGHT SERIES BEARING AND HOUSING

## 360 MM TO 600 MM (15 IN. TO 24 IN.)

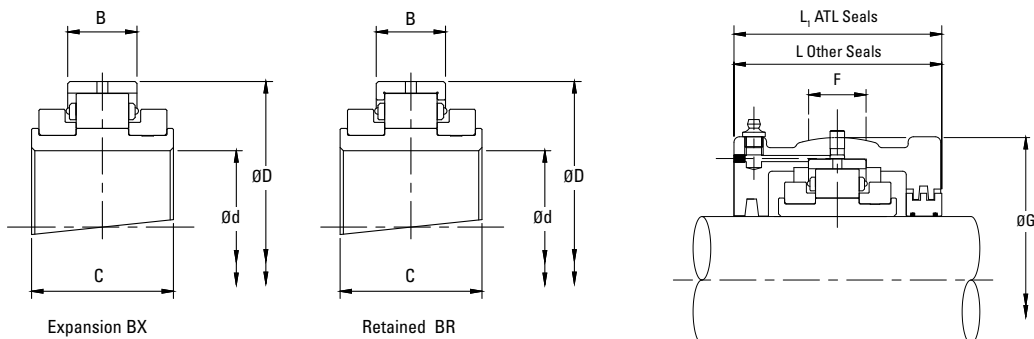

| Shaft (d)                                                           |                                                                          | Reference                                                           |         | Bearings Ratings       |                        |                      |        |                  |                | Housing Reference |           |                  |                  |                  |            |             |   |
|---------------------------------------------------------------------|--------------------------------------------------------------------------|---------------------------------------------------------------------|---------|------------------------|------------------------|----------------------|--------|------------------|----------------|-------------------|-----------|------------------|------------------|------------------|------------|-------------|---|
|                                                                     |                                                                          |                                                                     |         | Dynamic C <sub>r</sub> | Static C <sub>0r</sub> | Axial C <sub>a</sub> | Max    | D                | B              | C                 | ATL Seals |                  | Other Seal Types |                  | G          | F           | L |
| Add <b>BR</b> for Retained Add <b>BX</b> for Expansion e.g. LSM35BR | Add <b>HRTL</b> for Retained Add <b>HXTL</b> for Expansion e.g. LS11HRTL | Add <b>HR</b> for Retained Add <b>HX</b> for Expansion e.g. LSM35HR |         |                        |                        |                      |        |                  |                |                   |           |                  |                  |                  |            |             |   |
| mm                                                                  | in.                                                                      |                                                                     | kN lb.  | kN lb.                 | kN lb.                 | RPM                  | mm in. | mm in.           | mm in.         |                   |           | mm in.           | mm in.           | mm in.           | mm in.     |             |   |
| 360<br>380                                                          | 15                                                                       | LSM360<br>LSM380                                                    | LSE1500 | 1224<br>275166         | 2431<br>546511         | 110.40<br>24819      | 500    | 520.70<br>20.500 | 76.20<br>3.000 | 140.00<br>5.512   | LS20      | LSM360<br>LSM380 | LSE1500          | 571.50<br>22.500 | 98<br>3.9  | 260<br>10.2 | – |
| 400                                                                 | 16                                                                       | LSM400                                                              | LSE1600 | 1107<br>248864         | 2266<br>509417         | 115.60<br>25988      | 460    | 546.10<br>21.500 | 76.20<br>3.000 | 140.00<br>5.512   | LS21      | LSM400           | LSE1600          | 603.30<br>23.752 | 102<br>4.0 | 280<br>11.0 | – |
| 420                                                                 | 17                                                                       | LSM420                                                              | LSE1700 | 1146<br>257631         | 2418<br>543588         | 121.00<br>27202      | 430    | 571.50<br>22.500 | 76.20<br>3.000 | 140.00<br>5.512   | LS22      | LSM420           | LSE1700          | 628.70<br>24.752 | 102<br>4.0 | 292<br>11.5 | – |
| 440<br>460                                                          | 18                                                                       | LSM440<br>LSM460                                                    | LSE1800 | 1185<br>266399         | 2469<br>555053         | 127.20<br>28596      | 410    | 596.90<br>23.500 | 76.20<br>3.000 | 140.00<br>5.512   | LS23      | LSM440<br>LSM460 | LSE1800          | 650.90<br>25.626 | 4.3<br>108 | 304<br>12.0 | – |
| 480                                                                 | 19                                                                       | LSM480                                                              | LSE1900 | 1348<br>303042         | 2965<br>666559         | 132.60<br>29810      | 380    | 628.65<br>24.750 | 81.00<br>3.189 | 144.00<br>5.669   | LS24      | LSM480           | LSE1900          | 682.60<br>26.874 | 4.3<br>108 | 304<br>12.0 | – |
| 500                                                                 | 20                                                                       | LSM500                                                              | LSE2000 | 1392<br>312934         | 3139<br>705675         | 137.80<br>30979      | 360    | 654.05<br>25.750 | 80.20<br>3.157 | 168.00<br>6.614   | LS25      | LSM500           | LSE2000          | 717.60<br>28.252 | 114<br>4.5 | 304<br>12.0 | – |
| 530                                                                 | 21                                                                       | LSM530                                                              | LSE2100 | 1431<br>321702         | 3316<br>745466         | 140.60<br>31608      | 340    | 692.15<br>27.250 | 81.00<br>3.189 | 168.00<br>6.614   | LS26      | LSM530           | LSE2100          | 755.70<br>29.752 | 114<br>4.5 | 330<br>13.0 | – |
| 560                                                                 | 22                                                                       | LSM560                                                              | LSE2200 | 1472<br>330919         | 3490<br>784583         | 142.40<br>32013      | 330    | 717.55<br>28.250 | 81.00<br>3.189 | 168.00<br>6.614   | LS27      | LSM560           | LSE2200          | 781.10<br>30.752 | 114<br>4.5 | 336<br>13.2 | – |
| 580                                                                 | 23                                                                       | LSM580                                                              | LSE2300 | 1616<br>363291         | 3841<br>863491         | 144.00<br>32372      | 310    | 749.00<br>29.488 | 84.10<br>3.311 | 172.00<br>6.772   | LS28      | LSM580           | LSE2300          | 816.00<br>32.126 | 120<br>4.7 | 342<br>13.5 | – |
| 600                                                                 | 24                                                                       | LSM600                                                              | LSE2400 | 1660<br>373183         | 4033<br>906654         | 146.80<br>33002      | 300    | 774.70<br>30.500 | 84.10<br>3.311 | 172.00<br>6.772   | LS29      | LSM600           | LSE2400          | 841.40<br>33.126 | 120<br>4.7 | 342<br>13.5 | – |

For triple labyrinth seal designations, please refer to page 32-34.

# LIGHT SERIES SUPPORT

## S20 - S29

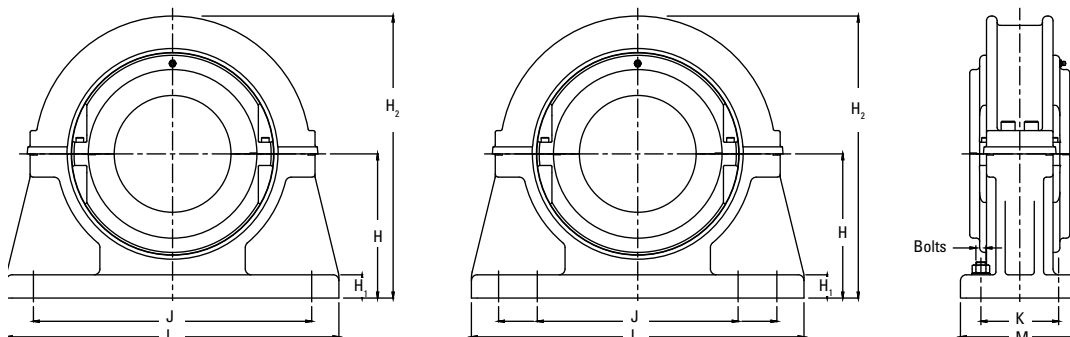

| Shaft (d)  |     | Support Reference | H             |           | H <sub>1</sub> |                                       | H <sub>2</sub> |                        | J x K |     | L x M |         | Bolts |
|------------|-----|-------------------|---------------|-----------|----------------|---------------------------------------|----------------|------------------------|-------|-----|-------|---------|-------|
| mm         | in. |                   | mm            | in.       | mm             | in.                                   | mm             | in.                    | mm    | in. | mm    | in.     |       |
| 360<br>380 | 15  | S20               | 397<br>15.630 | 60<br>2.4 | 795<br>31.3    | 676 x 166<br>26.6 x 6.5               |                | 902 x 254<br>35.5 x 10 |       |     |       | 4 x M36 |       |
| 400        | 16  | S21               | 432<br>17.008 | 67<br>2.6 | 865<br>34.1    | 724 x 166<br>28.5 x 6.5               |                | 940 x 254<br>37 x 10   |       |     |       | 4 x M36 |       |
| 420        | 17  | S22               | 445<br>17.520 | 67<br>2.6 | 890<br>35.0    | 756 x 166<br>29.8 x 6.5               |                | 966 x 254<br>38 x 10   |       |     |       | 4 x M36 |       |
| 440<br>460 | 18  | S23               | 464<br>18.268 | 70<br>2.8 | 925<br>36.4    | 788 x 190<br>31 x 7.5                 |                | 1042 x 280<br>41 x 11  |       |     |       | 4 x M42 |       |
| 480        | 19  | S24               | 483<br>19.016 | 73<br>2.9 | 965<br>38.0    | 816 x 188<br>32.1 x 7.4               |                | 1092 x 304<br>43 x 12  |       |     |       | 4 x M42 |       |
| 500        | 20  | S25               | 489<br>19.252 | 76<br>3.0 | 980<br>38.6    | 844 x 216<br>33.2 x 8.5               |                | 1092 x 304<br>43 x 12  |       |     |       | 4 x M42 |       |
| 530        | 21  | S26               | 533<br>20.984 | 80<br>3.1 | 1065<br>41.9   | 904 x 206<br>35.6 x 8.1               |                | 1194 x 304<br>47 x 12  |       |     |       | 4 x M42 |       |
| 560        | 22  | S27               | 552<br>21.732 | 83<br>3.3 | 1110<br>43.7   | 936 x 206<br>36.9 x 8.1               |                | 1220 x 304<br>48 x 12  |       |     |       | 4 x M42 |       |
| 580        | 23  | S28               | 578<br>22.756 | 83<br>3.3 | 1156<br>45.5   | 1080 & 877 x 220<br>42.5 & 34.5 x 8.7 |                | 1372 x 304<br>54 x 12  |       |     |       | 8 x M36 |       |
| 600        | 24  | S29               | 597<br>23.504 | 90<br>3.5 | 1200<br>47.2   | 1118 & 908 x 200<br>44 & 35.7 x 7.9   |                | 1372 x 304<br>54 x 12  |       |     |       | 8 x M36 |       |

**LIGHT SERIES SUPPORT  
FLANGE UNITS 35 MM - 305 MM (1 3/16 IN. TO 12 IN.)**

When faced with flat horizontal or vertical faces, flange units offer a simple mounting solution. As with pillow block supports, flange units are produced with spherical location to accommodate standard bearing housings and provide easy initial alignment of shaft and equipment.

To facilitate positive location of the flange to the surface, the rear face is recessed (dimensions N and V). This allows for a spigot (tolerance f8) to be located into the flange.

Bearing inspection is simply a matter of removing the top half of the flange and housing. Bearing replacement may also be achieved in the same manner if required.

When integrating flange units into new applications, it should be noted that a maximum radial load equivalent to 0.26 C<sub>r</sub> is permissible. A maximum axial load of 0.25 C<sub>a</sub> must also be taken into account for applications with thrust loading. Units for vertically oriented shafts may also need special consideration given to sealing arrangements.

As always, Timken will be happy to advise on any application issues.

| Shaft (d)         |                                    | Flange Reference | T           | Bolts   | R           | P         | H         | N                | V        | L          |
|-------------------|------------------------------------|------------------|-------------|---------|-------------|-----------|-----------|------------------|----------|------------|
| mm                | in.                                |                  |             |         |             |           |           |                  |          |            |
| 35<br>40          | 1 3/16<br>1 1/4<br>1 7/16<br>1 1/2 | F01              | 204<br>8.0  | 4 x M12 | 164<br>6.5  | 13<br>0.5 | 51<br>2.0 | 119.06<br>4.687  | 3<br>0.1 | 94<br>3.7  |
| 45<br>50          | 1 11/16<br>1 3/4<br>1 15/16<br>2   | F02              | 216<br>8.5  | 4 x M12 | 180<br>7.1  | 13<br>0.5 | 57<br>2.2 | 136.52<br>5.375  | 3<br>0.1 | 106<br>4.2 |
| 55<br>60<br>65    | 2 3/16<br>2 1/4<br>2 7/16<br>2 1/2 | F03              | 260<br>10.2 | 4 x M12 | 218<br>8.6  | 16<br>0.6 | 67<br>2.6 | 166.96<br>5.71   | 3<br>0.1 | 120<br>4.7 |
| 70<br>75          | 2 11/16<br>2 3/4<br>2 15/16<br>3   | F04              | 286<br>11.3 | 4 x M12 | 242<br>9.5  | 16<br>0.6 | 73<br>2.9 | 192.09<br>7.563  | 3<br>0.1 | 130<br>5.1 |
| 80<br>85<br>90    | 3 3/16<br>3 1/4<br>3 7/16<br>3 1/2 | F05              | 330<br>13.0 | 4 x M16 | 274<br>10.8 | 19<br>0.7 | 79<br>3.1 | 215.98<br>500    | 3<br>0.1 | 148<br>5.8 |
| 100<br>105        | 3 11/16<br>3 3/4<br>3 15/16<br>4   | F06              | 356<br>14.0 | 4 x M16 | 302<br>11.9 | 19<br>0.7 | 86<br>3.4 | 244.47<br>9.625  | 3<br>0.1 | 154<br>6.1 |
| 110<br>115        | 4 3/16<br>4 1/4<br>4 7/16<br>4 1/2 | F07              | 382<br>15.0 | 4 x M16 | 334<br>13.1 | 22<br>0.9 | 92<br>3.6 | 276.22<br>10.875 | 3<br>0.1 | 164<br>6.5 |
| 120<br>125<br>130 | 4 11/16<br>4 3/4<br>4 15/16<br>5   | F08              | 432<br>17.0 | 4 x M24 | 374<br>14.7 | 22<br>0.9 | 98<br>3.9 | 314.32<br>12.375 | 3<br>0.1 | 176<br>6.9 |

For bearings and housings see pages 46-49.

*continued on next page*

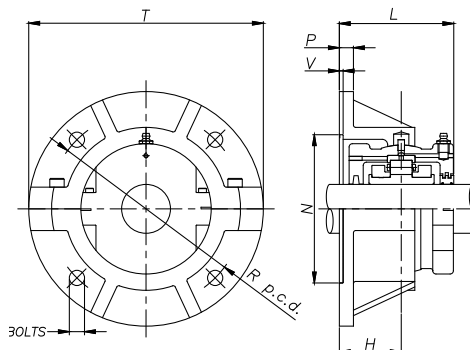

continued from previous page

| Shaft (d)          |                                    | Flange Reference | T           | Bolts   | R           | P         | H          | N                | V        | L           |
|--------------------|------------------------------------|------------------|-------------|---------|-------------|-----------|------------|------------------|----------|-------------|
| mm                 | in.                                |                  |             |         |             |           |            |                  |          |             |
| 135<br>140         | 5 3/16<br>5 1/4<br>5 7/16<br>5 1/2 | F09              | 444<br>17.5 | 4 x M24 | 384<br>15.1 | 25<br>1.0 | 98<br>3.9  | 317.51<br>2.500  | 3<br>0.1 | 182<br>7.2  |
| 150<br>155<br>160A | 5 11/16<br>5 3/4<br>5 15/16<br>6   | F10              | 470<br>18.5 | 4 x M24 | 412<br>16.2 | 25<br>1.0 | 114<br>4.5 | 346.07<br>13.625 | 3<br>0.1 | 202<br>8.0  |
| 160<br>170A        | 6 7/16<br>6 1/2                    | F11              | 496<br>19.5 | 4 x M24 | 426<br>16.8 | 25<br>1.0 | 105<br>4.1 | 352.42<br>13.875 | 3<br>0.1 | 202<br>8.0  |
| 170<br>175<br>180  | 6 11/16<br>6 3/4<br>6 15/16<br>7   | F12              | 508<br>20.0 | 4 x M24 | 438<br>17.2 | 29<br>1.1 | 108<br>4.3 | 365.12<br>14.375 | 3<br>0.1 | 208<br>8.2  |
| 190<br>200         | 7 1/4<br>7 1/2<br>7 15/16<br>8     | F13              | 534<br>21.0 | 4 x M24 | 474<br>18.7 | 32<br>1.3 | 108<br>4.3 | 400.05<br>15.750 | 3<br>0.1 | 208<br>8.2  |
| 220<br>230         | 8 1/2<br>8 7/8<br>9                | F14              | 584<br>23.0 | 4 x M30 | 512<br>20.2 | 35<br>1.4 | 117<br>4.6 | 431.81<br>7.000  | 3<br>0.1 | 226<br>8.9  |
| 240<br>250         | 9 1/2<br>9 3/4<br>10               | F15              | 610<br>24.0 | 4 x M30 | 542<br>21.3 | 35<br>1.4 | 117<br>4.6 | 463.55<br>18.250 | 3<br>0.1 | 228<br>9.0  |
| 260<br>270<br>280  | 10 1/2<br>10 3/4<br>11             | F16              | 660<br>26.0 | 4 x M30 | 584<br>23.0 | 38<br>1.5 | 124<br>4.9 | 504.82<br>19.875 | 3<br>0.1 | 240<br>9.4  |
| 300<br>305         | 11 1/2<br>12                       | F17              | 712<br>28.0 | 4 x M30 | 626<br>24.6 | 38<br>1.5 | 133<br>5.2 | 539.75<br>21.250 | 3<br>0.1 | 258<br>10.2 |

For bearings and housings see pages 46-49.

## LIGHT SERIES SUPPORT TAKE-UP UNITS TT/TP 35 MM TO 155 MM (1 3/16 IN. TO 6 IN.)

This type of split unit can be found in use on materials handling equipment in many industries. Take-up units provide an efficient and readily accessible means of tensioning conveyor systems and large scale drives.

The units consist of either push-type or pull-type sliding supports into which standard housings and bearings may be

mounted. When integrating take-up units into new applications, it should be noted that a maximum radial load equivalent to 0.3 C<sub>or</sub> is permissible. As with all Timken units, a wide variety of sealing solutions may be applied dependant on the environment and application. Please contact a Timken engineer for assistance.

| Shaft (d)      |                                    | Support Reference |           | B          | N           | D           | V          | P         | H         | S         | A          | T           | X         | W         | R         | U        | Y         |
|----------------|------------------------------------|-------------------|-----------|------------|-------------|-------------|------------|-----------|-----------|-----------|------------|-------------|-----------|-----------|-----------|----------|-----------|
|                |                                    | Tension-Type      | Push-Type |            |             |             |            |           |           |           |            |             |           |           |           |          |           |
| mm             | in.                                |                   |           | mm in.     | mm in.      | mm in.      | mm in.     | mm in.    | mm in.    | mm in.    | mm in.     | mm in.      | mm in.    | mm in.    | mm in.    | mm in.   | mm in.    |
| 35<br>40       | 1 3/16<br>1 1/4<br>1 7/16<br>1 1/2 | TT01              | TP01      | 102<br>4.0 | 172<br>6.8  | 153<br>6.0  | 76<br>3.0  | 14<br>0.6 | 29<br>1.1 | 25<br>1.0 | 32<br>1.3  | 216<br>8.5  | 20<br>0.8 | 25<br>1.0 | 24<br>0.9 | 5<br>0.2 | 13<br>0.5 |
| 45<br>50       | 1 11/16<br>1 3/4<br>1 15/16<br>2   | TT02              | TP02      | 114<br>4.5 | 204<br>8.0  | 178<br>7.0  | 88<br>3.5  | 16<br>0.6 | 29<br>1.1 | 29<br>1.1 | 128<br>5.0 | 242<br>9.5  | 24<br>0.9 | 25<br>1.0 | 25<br>1.0 | 5<br>0.2 | 13<br>0.5 |
| 55<br>60<br>65 | 2 3/16<br>2 1/4<br>2 7/16<br>2 1/2 | TT03              | TP03      | 128<br>5.0 | 235<br>9.3  | 203<br>8.0  | 102<br>4.0 | 20<br>0.8 | 32<br>1.3 | 38<br>1.5 | 146<br>5.7 | 280<br>11.0 | 24<br>0.9 | 30<br>1.2 | 29<br>1.1 | 6<br>0.2 | 16<br>0.6 |
| 70<br>75       | 2 11/16<br>2 3/4<br>2 15/16<br>3   | TT04              | TP04      | 152<br>6.0 | 266<br>10.5 | 229<br>9.0  | 114<br>4.5 | 22<br>0.9 | 40<br>1.6 | 41<br>1.6 | 158<br>6.2 | 305<br>12.0 | 24<br>0.9 | 30<br>1.2 | 32<br>1.3 | 6<br>0.2 | 16<br>0.5 |
| 80<br>85<br>90 | 3 3/16<br>3 1/4<br>3 7/16<br>3 1/2 | TT05              | TP05      | 190<br>7.5 | 318<br>12.5 | 280<br>11.0 | 140<br>5.5 | 22<br>0.9 | 40<br>1.6 | 51<br>2.0 | 190<br>7.5 | 368<br>14.5 | 30<br>1.2 | 38<br>1.5 | 35<br>1.4 | 6<br>0.2 | 16<br>0.5 |

For bearings and housings see pages 46-49.

continued on next page



LIGHT SERIES • LIGHT SERIES SUPPORT • TAKE-UP UNITS TT/TP 35 MM TO 155 MM (1 3/16 IN. TO 6 IN.)

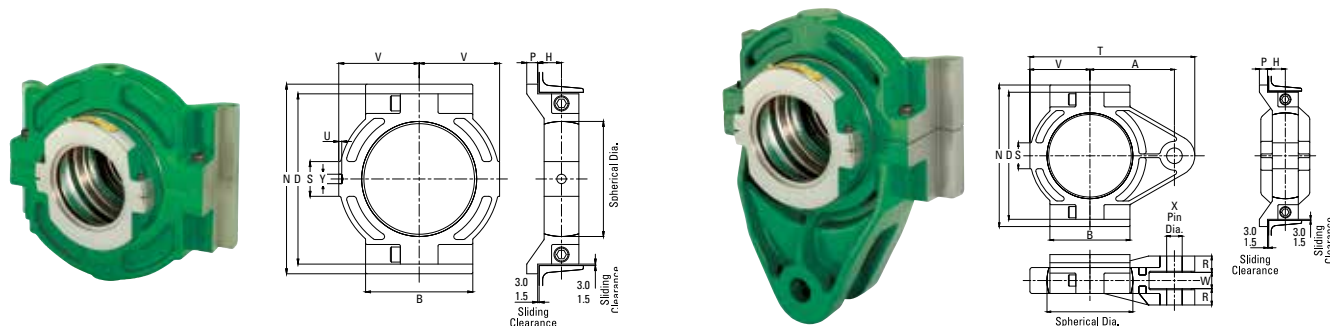

continued from previous page

| Shaft (d)  |                          | Support Reference |           | B          | N          | D          | V          | P         | H         | S         | A          | T          | X         | W         | R         | U        | Y         |
|------------|--------------------------|-------------------|-----------|------------|------------|------------|------------|-----------|-----------|-----------|------------|------------|-----------|-----------|-----------|----------|-----------|
|            |                          | Tension-Type      | Push-Type |            |            |            |            |           |           |           |            |            |           |           |           |          |           |
| mm         | in.                      |                   |           | mm in.     | mm in.     | mm in.     | mm in.     | mm in.    | mm in.    | mm in.    | mm in.     | mm in.     | mm in.    | mm in.    | mm in.    | mm in.   | mm in.    |
| <b>100</b> | 3 11/16                  | TT06              | TP06      | <b>204</b> | <b>342</b> | <b>305</b> | <b>152</b> | <b>22</b> | <b>43</b> | <b>51</b> | <b>210</b> | <b>414</b> | <b>36</b> | <b>44</b> | <b>35</b> | <b>6</b> | <b>19</b> |
| <b>105</b> | 3 3/4<br>3 15/16<br>4    |                   |           |            |            |            |            |           |           |           |            |            |           |           |           |          |           |
| <b>110</b> | 4 3/16                   | TT07              | TP07      | <b>216</b> | <b>382</b> | <b>343</b> | <b>162</b> | <b>22</b> | <b>48</b> | <b>70</b> | <b>228</b> | <b>445</b> | <b>42</b> | <b>44</b> | <b>41</b> | <b>6</b> | <b>19</b> |
| <b>115</b> | 4 1/4<br>4 7/16<br>4 1/2 |                   |           |            |            |            |            |           |           |           |            |            |           |           |           |          |           |
| <b>120</b> | 4 11/16                  | TT08              | TP08      | <b>254</b> | <b>420</b> | <b>381</b> | <b>190</b> | <b>25</b> | <b>51</b> | <b>76</b> | <b>260</b> | <b>508</b> | <b>42</b> | <b>44</b> | <b>44</b> | <b>6</b> | <b>19</b> |
| <b>125</b> | 4 3/4                    |                   |           |            |            |            |            |           |           |           |            |            |           |           |           |          |           |
| <b>130</b> | 4 15/16<br>5             |                   |           |            |            |            |            |           |           |           |            |            |           |           |           |          |           |
| <b>135</b> | 5 3/16                   | TT09              | TP09      | <b>266</b> | <b>438</b> | <b>400</b> | <b>196</b> | <b>25</b> | <b>54</b> | <b>76</b> | <b>266</b> | <b>514</b> | <b>42</b> | <b>44</b> | <b>48</b> | <b>8</b> | <b>23</b> |
| <b>140</b> | 5 1/4<br>5 7/16<br>5 1/2 |                   |           |            |            |            |            |           |           |           |            |            |           |           |           |          |           |
| <b>150</b> | 5 11/16                  | TT10              | TP10      | <b>266</b> | <b>464</b> | <b>426</b> | <b>204</b> | <b>25</b> | <b>57</b> | <b>86</b> | <b>280</b> | <b>546</b> | <b>48</b> | <b>50</b> | <b>51</b> | <b>8</b> | <b>23</b> |
| <b>155</b> | 5 3/4                    |                   |           |            |            |            |            |           |           |           |            |            |           |           |           |          |           |
| <b>160</b> | 5 15/16<br>6             |                   |           |            |            |            |            |           |           |           |            |            |           |           |           |          |           |

For bearings and housings see pages 46-49.

## LIGHT SERIES SUPPORT HANGER UNITS

Timken hanger units are the optimum solution for the support of screw conveyor shafts. The unit is comprised of a cast iron split housing into which expansion-type split cylindrical roller bearings are fitted. Provision of a drilled and tapped boss in one half of the housing allows for the unit to be mounted from the conveyor cross bracing or any other suitable surface. It is recommended that some form of swivel fixing be incorporated into the mounting arrangement to allow for static alignment.

Due to the arduous conditions often found in screw conveyor applications, correct seal selection is critical. Timken hanger units are available with many sealing variants, all of which can

also be tailored to suit specific applications. When integrating hanging units into new applications, it should be noted that a maximum radial load equivalent to 0.3 C<sub>or</sub> is permissible. Only suitable for an expansion (BX) type bearings. Please contact a Timken engineer for further information.

Hanger units have two seal grooves per side. They are supplied with double felt seals as standard. However, the standard seal groove will accept any combination of strip seal.

A further option is to have a tapped hole between the seal grooves at each end of the housing to incorporate a grease or air supply to purge the seals.

| Shaft (d)      |         | Support Reference             |          | C             | G          | L          | H          | X <sup>(1)</sup>     | Y         |
|----------------|---------|-------------------------------|----------|---------------|------------|------------|------------|----------------------|-----------|
| mm             | in.     | mm                            | in.      | mm in.        | mm in.     | mm in.     | mm in.     | mm in.               | mm in.    |
| 35<br>40       | 1 3/16  | LSM35HG<br>LSM40HG            | LSE103HG | 55.0<br>2.165 | 106<br>4.2 | 108<br>4.3 | 66<br>2.6  | M30<br>1 - 8 UNC     | 50<br>2.0 |
|                | 1 1/4   |                               | LSE104HG |               |            |            |            |                      |           |
|                | 1 7/16  |                               | LSE107HG |               |            |            |            |                      |           |
|                | 1 1/2   |                               | LSE108HG |               |            |            |            |                      |           |
| 45<br>50       | 1 11/16 | LSM45HG<br>LSM50HG            | LSE111HG | 60.0<br>2.362 | 121<br>4.8 | 108<br>4.3 | 76<br>3.0  | M30<br>1 - 8 UNC     | 50<br>2.0 |
|                | 1 3/4   |                               | LSE112HG |               |            |            |            |                      |           |
|                | 1 15/16 |                               | LSE115HG |               |            |            |            |                      |           |
|                | 2       |                               | LSE200HG |               |            |            |            |                      |           |
| 55<br>60<br>65 | 2 3/16  | LSM55HG<br>LSM60HG<br>LSM65HG | LSE203HG | 60.0<br>2.362 | 140<br>5.5 | 108<br>4.3 | 82<br>3.2  | M30<br>1 - 8 UNC     | 50<br>2.0 |
|                | 2 1/4   |                               | LSE204HG |               |            |            |            |                      |           |
|                | 2 7/16  |                               | LSE207HG |               |            |            |            |                      |           |
|                | 2 1/2   |                               | LSE208HG |               |            |            |            |                      |           |
| 70<br>75       | 2 11/16 | LSM70HG<br>LSM75HG            | LSE211HG | 65.0<br>2.559 | 162<br>6.4 | 130<br>5.1 | 92<br>3.6  | M30<br>1 - 8 UNC     | 50<br>2.0 |
|                | 2 3/4   |                               | LSE212HG |               |            |            |            |                      |           |
|                | 2 15/16 |                               | LSE215HG |               |            |            |            |                      |           |
|                | 3       |                               | LSE300HG |               |            |            |            |                      |           |
| 80<br>85<br>90 | 3 3/16  | LSM80HG<br>LSM85HG<br>LSM90HG | LSE303HG | 75.0<br>2.953 | 187<br>7.4 | 146<br>5.7 | 114<br>4.5 | M36<br>1 1/2 - 6 UNC | 76<br>3.0 |
|                | 3 1/4   |                               | LSE304HG |               |            |            |            |                      |           |
|                | 3 7/16  |                               | LSE307HG |               |            |            |            |                      |           |
|                | 3 1/2   |                               | LSE308HG |               |            |            |            |                      |           |

<sup>(1)</sup> Hanger units with inch bore sizes have UNC mounting threads as standard. Hanger units with metric bore sizes have metric mounting threads as standard

*continued on next page*

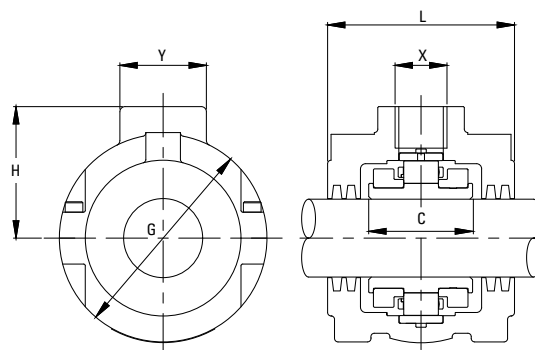
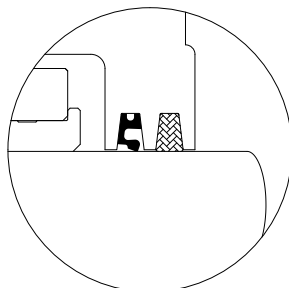

continued from previous page

| Shaft (d) |         | Support Reference    |          | C         | G         | L         | H         | X <sup>(1)</sup> | Y         |
|-----------|---------|----------------------|----------|-----------|-----------|-----------|-----------|------------------|-----------|
| mm        | in.     |                      |          | mm<br>in. | mm<br>in. | mm<br>in. | mm<br>in. | mm<br>in.        | mm<br>in. |
| 100       | 3 1/16  | LSM100HG<br>LSM105HG | LSE311HG | 85.0      | 210       | 152       | 128       | M36              | 76        |
|           | 3 3/4   |                      | LSE312HG |           |           |           |           |                  |           |
| 105       | 3 15/16 | LSM100HG<br>LSM105HG | LSE315HG | 3.346     | 8.3       | 6.0       | 5.0       | 1 1/2 - 6 UNC    | 3.0       |
|           | 4       |                      | LSE400HG |           |           |           |           |                  |           |
| 110       | 4 3/16  | LSM110HG<br>LSM115HG | LSE403HG | 90.0      | 232       | 156       | 140       | M36              | 76        |
|           | 4 1/4   |                      | LSE404HG |           |           |           |           |                  |           |
| 115       | 4 7/16  | LSM110HG<br>LSM115HG | LSE407HG | 3.543     | 9.1       | 6.1       | 5.5       | 1 1/2 - 6 UNC    | 3.0       |
|           | 4 1/2   |                      | LSE408HG |           |           |           |           |                  |           |
| 120       | 4 11/16 | LSM120<br>LSM125     | LSE411   | 95        | 276       | 162       | 156       | M36              | 76        |
|           | 4 3/4   |                      | LSE412   |           |           |           |           |                  |           |
| 125       | 4 15/16 | LSM120<br>LSM125     | LSE415   | 3.740     | 10.866    | 6.378     | 6.142     | 1 1/2 - 6 UNC    | 2.992     |
|           | 5       |                      | LSE500   |           |           |           |           |                  |           |
| 130       | 5 1/16  | LSM135<br>LSM140     | LSE503   | 98.4      | 280       | 158       | 160       | M36              | 75        |
|           | 5 1/4   |                      | LSE504   |           |           |           |           |                  |           |
| 135       | 5 7/16  | LSM135<br>LSM140     | LSE507   | 3.874     | 11.024    | 6.220     | 6.299     | 1 1/2 - 6 UNC    | 2.953     |
|           | 5 1/2   |                      | LSE508   |           |           |           |           |                  |           |

<sup>(1)</sup> Hanger units with inch bore sizes have UNC mounting threads as standard. Hanger units with metric bore sizes have metric mounting threads as standard



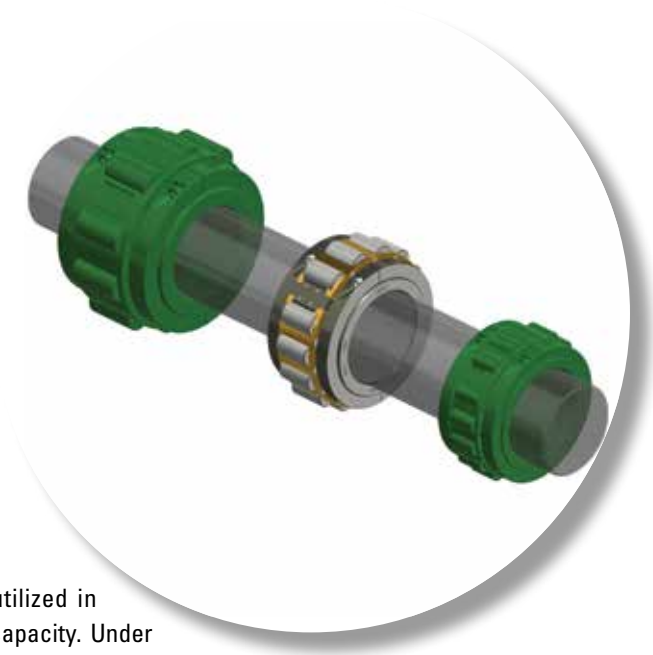

## ***MEDIUM SERIES***

Medium series bearing products can be utilized in applications requiring higher load-carrying capacity. Under normal conditions, medium series also may be selected to provide an extended bearing life when compared to light series. Medium series offers the same range of mounting and sealing solutions as light series, with the exception of hanger units. If a standard catalog product does not meet your requirements, a Timken engineer will be happy to provide help and advice on your application.

The following topics are covered within this section:

|                                           |    |
|-------------------------------------------|----|
| Medium Series Bearing and Housing         |    |
| 45 mm to 155 mm (1 1/8 in. to 6 in.)      | 60 |
| Medium Series Support S03 - S31           | 61 |
| Medium Series Bearing and Housing         |    |
| 160 mm to 360 mm (6 3/8 in. to 14 in.)    | 62 |
| Medium Series Support S32 - S40           | 63 |
| Medium Series Bearing and Housing         |    |
| 380 mm to 600 mm (15 in. to 24 in.)       | 64 |
| Medium Series Support S41 - S50           | 65 |
| Medium Series Support Flange Units        |    |
| 45 mm to 305 mm (1 1/8 in. to 12 in.)     | 66 |
| Medium Series Support Take-Up Units TT/TP |    |
| 45 mm to 155 mm (1 1/8 in. to 6 in.)      | 68 |

# MEDIUM SERIES BEARING AND HOUSING

## 45 MM TO 155 MM (1 1/16 IN. TO 6 IN.)

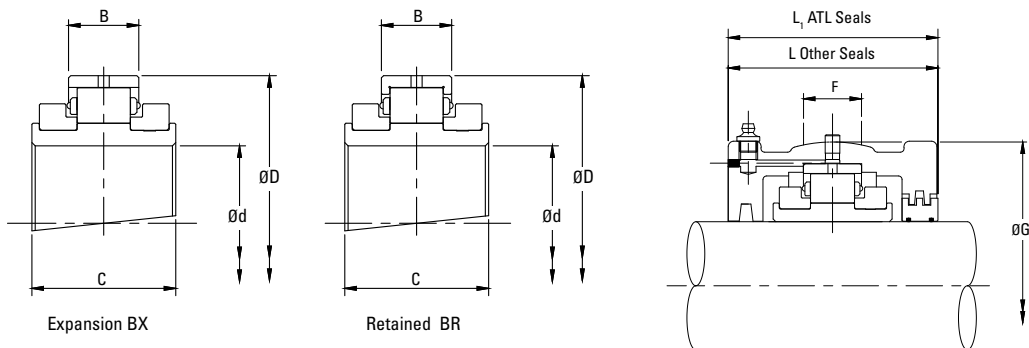

| Shaft (d) |         | Reference |        | Bearings Ratings       |                        |                      |      |        |        | Housing Reference |                                                                        |                                                                           |        |        |        |                |     |
|-----------|---------|-----------|--------|------------------------|------------------------|----------------------|------|--------|--------|-------------------|------------------------------------------------------------------------|---------------------------------------------------------------------------|--------|--------|--------|----------------|-----|
|           |         |           |        | Dynamic C <sub>r</sub> | Static C <sub>0r</sub> | Axial C <sub>a</sub> | Max  | D      | B      | C                 | ATL Seals<br>Add HRTL for Retained Add HXTL for Expansion e.g. MS3HRTL | Other Seal Types<br>Add HR for Retained Add HX for Expansion e.g. MSM55HR | G      | F      | L      | L <sub>1</sub> |     |
| mm        | in.     |           |        | kN lb.                 | kN lb.                 | kN lb.               | RPM  | mm in. | mm in. | mm in.            |                                                                        |                                                                           | mm in. | mm in. | mm in. | mm in.         |     |
| 45        | 1 1/16  | MSM45     | MSE111 | 121                    | 127                    | 6.20                 | 4350 | 107.95 | 35.00  | 67.50             | MS3                                                                    | MSM45                                                                     | MSE111 | 134.94 | 32     | 112            | 114 |
|           | 1 3/4   |           | MSE112 |                        |                        |                      |      |        |        |                   |                                                                        |                                                                           | MSE112 |        |        |                |     |
| 50        | 1 15/16 | MSM50     | MSE115 | 27202                  | 28551                  | 1394                 | 4350 | 4.250  | 1.378  | 2.657             | MS3                                                                    | MSM50                                                                     | MSE115 | 5.313  | 1.3    | 4.4            | 4.5 |
|           | 2       |           | MSE200 |                        |                        |                      |      |        |        |                   |                                                                        |                                                                           | MSE200 |        |        |                |     |
| 55        | 2 3/16  | MSM55     | MSE203 | 168                    | 190                    | 8.80                 | 3680 | 127.00 | 38.90  | 72.30             | MS4                                                                    | MSM55                                                                     | MSE203 | 157.16 | 38     | 124            | 126 |
|           | 2 1/4   |           | MSE204 |                        |                        |                      |      |        |        |                   |                                                                        |                                                                           | MSE204 |        |        |                |     |
| 60        | 2 1/2   | MSM60     | MSE207 | 37768                  | 42714                  | 1978                 | 3680 | 5.000  | 1.531  | 2.846             | MS4                                                                    | MSM60                                                                     | MSE207 | 6.187  | 1.5    | 4.9            | 5.0 |
|           | 2 1/2   |           | MSE208 |                        |                        |                      |      |        |        |                   |                                                                        |                                                                           | MSE208 |        |        |                |     |
| 70        | 2 11/16 | MSM70     | MSE211 | 258                    | 300                    | 10.60                | 3080 | 149.22 | 46.10  | 82.60             | MS5                                                                    | MSM70                                                                     | MSE211 | 177.80 | 50     | 138            | 140 |
|           | 2 3/4   |           | MSE212 |                        |                        |                      |      |        |        |                   |                                                                        |                                                                           | MSE212 |        |        |                |     |
| 75        | 2 15/16 | MSM75     | MSE215 | 58001                  | 67443                  | 2383                 | 3080 | 5.875  | 1.815  | 3.252             | MS5                                                                    | MSM75                                                                     | MSE215 | 7.000  | 2.0    | 5.4            | 5.5 |
|           | 3       |           | MSE300 |                        |                        |                      |      |        |        |                   |                                                                        |                                                                           | MSE300 |        |        |                |     |
| 80        | 3 3/16  | MSM80     | MSE303 | 297                    | 353                    | 17.80                | 2520 | 169.86 | 48.40  | 89.70             | MS6                                                                    | MSM80                                                                     | MSE303 | 203.20 | 50     | 152            | 154 |
|           | 3 1/4   |           | MSE304 |                        |                        |                      |      |        |        |                   |                                                                        |                                                                           | MSE304 |        |        |                |     |
| 85        | 3 1/2   | MSM85     | MSE307 | 66768                  | 79358                  | 4002                 | 2520 | 6.687  | 1.906  | 3.531             | MS6                                                                    | MSM85                                                                     | MSE307 | 8.000  | 2.0    | 6.0            | 6.1 |
|           | 3 1/2   |           | MSE308 |                        |                        |                      |      |        |        |                   |                                                                        |                                                                           | MSE308 |        |        |                |     |
| 90        | 3 1/2   | MSM90     | MSE308 | 66768                  | 79358                  | 4002                 | 2520 | 6.687  | 1.906  | 3.531             | MS6                                                                    | MSM90                                                                     | MSE308 | 8.000  | 2.0    | 6.0            | 6.1 |
|           | 3 1/2   |           | MSE308 |                        |                        |                      |      |        |        |                   |                                                                        |                                                                           | MSE308 |        |        |                |     |
| 100       | 3 11/16 | MSM100    | MSE311 | 388                    | 491                    | 25.00                | 2130 | 193.68 | 51.60  | 92.10             | MS7                                                                    | MSM100                                                                    | MSE311 | 231.78 | 64     | 144            | 146 |
|           | 3 3/4   |           | MSE312 |                        |                        |                      |      |        |        |                   |                                                                        |                                                                           | MSE312 |        |        |                |     |
| 105       | 3 15/16 | MSM105    | MSE315 | 87226                  | 110381                 | 5620                 | 2130 | 7.625  | 2.031  | 3.626             | MS7                                                                    | MSM105                                                                    | MSE315 | 9.125  | 2.5    | 5.7            | 5.7 |
|           | 4       |           | MSE400 |                        |                        |                      |      |        |        |                   |                                                                        |                                                                           | MSE400 |        |        |                |     |
| 110       | 4 3/16  | MSM110    | MSE403 | 454                    | 592                    | 31.20                | 1820 | 228.60 | 57.20  | 100.00            | MS8                                                                    | MSM110                                                                    | MSE403 | 266.70 | 76     | 160            | 162 |
|           | 4 1/4   |           | MSE404 |                        |                        |                      |      |        |        |                   |                                                                        |                                                                           | MSE404 |        |        |                |     |
| 115       | 4 1/2   | MSM115    | MSE407 | 102063                 | 133087                 | 7014                 | 1820 | 9.000  | 2.252  | 3.937             | MS8                                                                    | MSM115                                                                    | MSE407 | 10.500 | 3.0    | 6.3            | 6.4 |
|           | 4 1/2   |           | MSE408 |                        |                        |                      |      |        |        |                   |                                                                        |                                                                           | MSE408 |        |        |                |     |
| 120       | 4 11/16 | MSM120    | MSE411 | 525                    | 700                    | 38.20                | 1600 | 254.00 | 63.50  | 114.30            | MS10                                                                   | MSM120                                                                    | MSE411 | 295.28 | 82     | 182            | 184 |
|           | 4 3/4   |           | MSE412 |                        |                        |                      |      |        |        |                   |                                                                        |                                                                           | MSE412 |        |        |                |     |
| 125       | 4 15/16 | MSM125    | MSE415 | 118025                 | 157366                 | 8588                 | 1600 | 10.000 | 2.500  | 4.500             | MS10                                                                   | MSM125                                                                    | MSE415 | 11.625 | 3.2    | 7.2            | 7.2 |
|           | 5       |           | MSE500 |                        |                        |                      |      |        |        |                   |                                                                        |                                                                           | MSE500 |        |        |                |     |
| 130       | 5       | MSM130    | MSE500 | 118025                 | 157366                 | 8588                 | 1600 | 10.000 | 2.500  | 4.500             | MS10                                                                   | MSM130                                                                    | MSE500 | 11.625 | 3.2    | 7.2            | 7.2 |
|           | 5       |           | MSE500 |                        |                        |                      |      |        |        |                   |                                                                        |                                                                           | MSE500 |        |        |                |     |
| 135       | 5 3/16  | MSM135    | MSE503 | 600                    | 817                    | 45.40                | 1450 | 273.05 | 66.70  | 117.50            | MS30                                                                   | MSM135                                                                    | MSE503 | 323.85 | 90     | 186            | 188 |
|           | 5 1/4   |           | MSE504 |                        |                        |                      |      |        |        |                   |                                                                        |                                                                           | MSE504 |        |        |                |     |
| 140       | 5 1/2   | MSM140    | MSE507 | 134885                 | 183669                 | 10206                | 1450 | 10.750 | 2.626  | 4.626             | MS30                                                                   | MSM140                                                                    | MSE507 | 12.750 | 3.5    | 7.3            | 7.4 |
|           | 5 1/2   |           | MSE508 |                        |                        |                      |      |        |        |                   |                                                                        |                                                                           | MSE508 |        |        |                |     |
| 150       | 5 11/16 | MSM150    | MSE511 | 730                    | 1034                   | 52.40                | 1320 | 292.10 | 68.30  | 123.80            | MS31                                                                   | MSM150                                                                    | MSE511 | 336.55 | 95     | 202            | 204 |
|           | 5 3/4   |           | MSE512 |                        |                        |                      |      |        |        |                   |                                                                        |                                                                           | MSE512 |        |        |                |     |
| 155       | 5 15/16 | MSM155    | MSE515 | 164111                 | 232453                 | 11780                | 1320 | 11.500 | 2.689  | 4.874             | MS32E0548                                                              | MSM155                                                                    | MSE515 | 13.250 | 3.7    | 8.0            | 8.0 |
|           | 5 15/16 |           | MSE600 |                        |                        |                      |      |        |        |                   |                                                                        |                                                                           | MSE600 |        |        |                |     |
| 160       | 6       | MSM160A   | MSE600 | 164111                 | 232453                 | 11780                | 1320 | 11.500 | 2.689  | 4.874             | MS32E0548                                                              | MSM160A                                                                   | MSE600 | 13.250 | 3.7    | 8.0            | 8.0 |

For triple labyrinth seal designations, please refer to page 32-34.

# MEDIUM SERIES SUPPORT

## S03 - S31

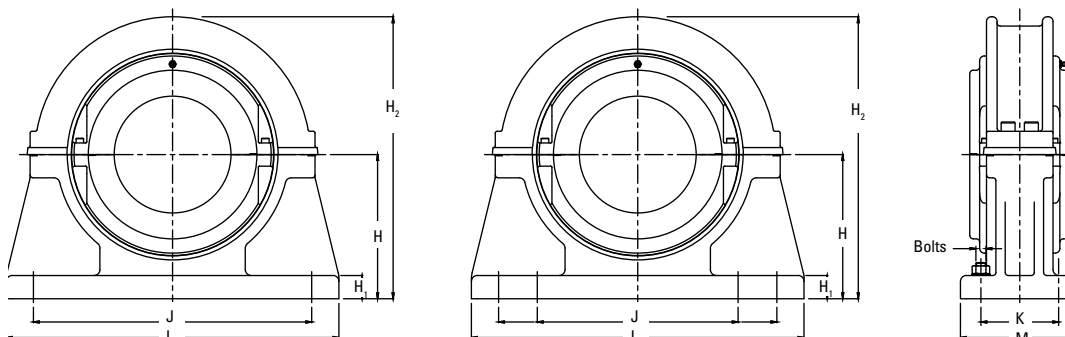

| Shaft (d)         |                                    | Support Reference                  | H             | H <sub>1</sub>               | H <sub>2</sub>           | J x K                        | L x M                                    | Bolts                                                |
|-------------------|------------------------------------|------------------------------------|---------------|------------------------------|--------------------------|------------------------------|------------------------------------------|------------------------------------------------------|
| mm                | in.                                |                                    |               |                              |                          |                              |                                          |                                                      |
| 45<br>50          | 1 11/16<br>1 3/4<br>1 15/16<br>2   | S03                                | 80<br>3.150   | 32<br>1.3                    | 180<br>7.1               | 234<br>9.2                   | 280 x 70<br>11 x 2.8                     | 2 x M16                                              |
|                   | 55<br>60<br>65                     |                                    | S04           | 95<br>3.740                  | 38<br>1.5                | 208<br>8.2                   | 270<br>10.6                              |                                                      |
| 70<br>75          | 2 11/16<br>2 3/4<br>2 15/16<br>3   | S05<br>S05-4B                      |               | 112<br>4.409<br>112<br>4.409 | 44<br>1.7<br>44<br>1.7   | 242<br>9.53<br>242<br>9.53   | 320<br>12.6<br>328 x 88.9<br>12.9 x 3.5  | 380 x 90<br>15 x 3.5<br>380 x 140<br>15 x 5.51       |
|                   | 80<br>85<br>90                     | 3 3/16<br>3 1/4<br>3 7/16<br>3 1/2 | S06<br>S06-4B | 125<br>4.921<br>125<br>4.921 | 55<br>2.17<br>55<br>2.17 | 265<br>10.43<br>265<br>10.43 | 354<br>13.9<br>368 x 102<br>14.5 x 4     | 420 x 102<br>16.5 x 4<br>426 x 152<br>16.8 x 6       |
| 100<br>105        |                                    | 3 11/16<br>3 3/4<br>3 15/16<br>4   | S07<br>S07-4B | 143<br>5.630<br>143<br>5.630 | 60<br>2.4<br>60<br>2.4   | 303<br>11.93<br>303<br>11.93 | 392<br>15.4<br>412 x 114.3<br>16.2 x 4.5 | 466 x 120<br>18.3 x 4.7<br>476 x 172<br>17.74 x 6.77 |
|                   | 110<br>115                         | S08                                | 162<br>6.378  | 38<br>1.5                    | 372<br>14.6              | 450 x 120<br>17.7 x 4.7      | 508 x 178<br>20 x 7                      | 4 x M24                                              |
| 120<br>125<br>130 | S10                                |                                    | 181<br>7.126  | 40<br>1.6                    | 415<br>16.3              | 496 x 120<br>19.5 x 4.7      | 558 x 178<br>22 x 7                      | 4 x M24                                              |
| 135<br>140        | 5 3/16<br>5 1/4<br>5 7/16<br>5 1/2 | S30                                | 203<br>7.992  | 50<br>2.0                    | 460<br>18.1              | 546 x 120<br>21.5 x 4.7      | 610 x 178<br>24 x 7                      | 4 x M24                                              |
| 150<br>155<br>160 | 5 11/16<br>5 3/4<br>5 15/16<br>6   |                                    | S31           | 210<br>8.268                 | 50<br>2.0                | 470<br>18.5                  | 558 x 128<br>22 x 5                      | 636 x 204<br>25 x 8                                  |

# MEDIUM SERIES BEARING AND HOUSING

## 160 MM TO 360 MM (6 7/16 IN. TO 14 IN.)

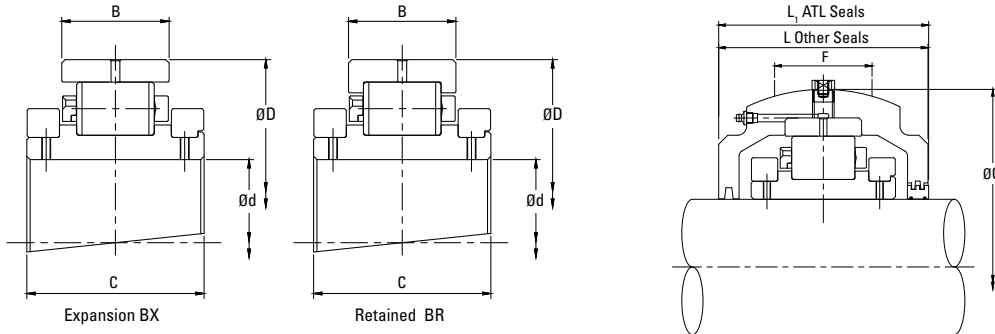

| Shaft (d)         |         | Reference                  |         | Bearings Ratings |                |                 |      |                  |                 | Housing Reference |                                                                        |                                                                            |         |                  |            |             |             |
|-------------------|---------|----------------------------|---------|------------------|----------------|-----------------|------|------------------|-----------------|-------------------|------------------------------------------------------------------------|----------------------------------------------------------------------------|---------|------------------|------------|-------------|-------------|
|                   |         |                            |         | Dynamic Cr       | Static Cor     | Axial Ca        | Max  | D                | B               | C                 | ATL Seals<br>Add HRTL for Retained Add HXTL for Expansion e.g. MS3HRTL | Other Seal Types<br>Add HR for Retained Add HX for Expansion e.g. MSM160HR | G       | F                | L          | L1          |             |
| mm                | in.     |                            |         | kN lb.           | kN lb.         | kN lb.          | RPM  | mm in.           | mm in.          | mm in.            |                                                                        |                                                                            | mm in.  | mm in.           | mm in.     | mm in.      |             |
| 160<br>170        | 6 7/16  | MSM160<br>MSM170           | MSE607  | 842<br>189289    | 1175<br>264151 | 61.40<br>13803  | 1200 | 317.50<br>12.500 | 83.30<br>3.280  | 140.00<br>5.512   | MS32                                                                   | MSM160<br>MSM170                                                           | MSE607  | 368.30<br>14.500 | 95<br>3.7  | 206<br>8.1  | 232<br>9.1  |
|                   | 6 1/2   |                            | MSE608  |                  |                |                 |      |                  |                 |                   |                                                                        |                                                                            | MSE608  |                  |            |             |             |
|                   | 6 11/16 |                            | MSE611  |                  |                |                 |      |                  |                 |                   |                                                                        |                                                                            | MSE611  |                  |            |             |             |
|                   | 6 3/4   |                            | MSE612  |                  |                |                 |      |                  |                 |                   |                                                                        |                                                                            | MSE612  |                  |            |             |             |
| 175<br>180        | 6 15/16 | MSM175<br>MSM180           | MSE615  | 927<br>208398    | 1357<br>305066 | 71.20<br>16006  | 1120 | 330.20<br>13.000 | 83.30<br>3.280  | 140.00<br>5.512   | MS33                                                                   | MSM175<br>MSM180                                                           | MSE615  | 381.00<br>15.000 | 95<br>3.7  | 222<br>8.7  | 242<br>9.5  |
|                   | 7       |                            | MSE700  |                  |                |                 |      |                  |                 |                   |                                                                        |                                                                            | MSE700  |                  |            |             |             |
| 190<br>200        | 7 1/4   | MSM190<br>MSM200           | MSE704  | 1013<br>227732   | 1516<br>340810 | 80.00<br>17985  | 960  | 368.30<br>14.500 | 90.50<br>3.563  | 156.00<br>6.142   | MS34                                                                   | MSM190<br>MSM200                                                           | MSE704  | 425.50<br>16.752 | 105<br>4.1 | 235<br>9.3  | 258<br>10.2 |
|                   | 7 1/2   |                            | MSE708  |                  |                |                 |      |                  |                 |                   |                                                                        |                                                                            | MSE708  |                  |            |             |             |
| 220<br>230        | 7 15/16 | MSM220<br>MSM230           | MSE715  | 1138<br>255833   | 1668<br>374981 | 89.80<br>20188  | 850  | 393.70<br>15.500 | 90.50<br>3.563  | 163.00<br>6.417   | MS35                                                                   | MSM220<br>MSM230                                                           | MSE715  | 457.20<br>18.000 | 110<br>4.3 | 242<br>9.5  | 274<br>10.8 |
|                   | 8       |                            | MSE800  |                  |                |                 |      |                  |                 |                   |                                                                        |                                                                            | MSE800  |                  |            |             |             |
| 240<br>250<br>260 | 8 1/2   | MSM240<br>MSM250<br>MSM260 | MSE808  | 1354<br>304391   | 2117<br>475921 | 98.80<br>22211  | 750  | 431.80<br>17.000 | 96.80<br>3.811  | 170.00<br>6.693   | MS36                                                                   | MSM240<br>MSM250                                                           | MSE808  | 495.30<br>19.500 | 118<br>4.6 | 248<br>9.8  | 280<br>11.0 |
|                   | 8 7/8   |                            | MSE814  |                  |                |                 |      |                  |                 |                   |                                                                        |                                                                            | MSE814  |                  |            |             |             |
|                   | 9       |                            | MSE900  |                  |                |                 |      |                  |                 |                   |                                                                        |                                                                            | MSE900  |                  |            |             |             |
| 270<br>280        | 9 1/4   | MSM270<br>MSM280           | MSE908  | 1476<br>331818   | 2357<br>529875 | 113.80<br>25583 | 670  | 463.55<br>18.250 | 101.60<br>4.000 | 186.00<br>7.323   | MS37                                                                   | MSM270<br>MSM280                                                           | MSE908  | 527.10<br>20.752 | 130<br>5.1 | 264<br>10.4 | 300<br>11.8 |
|                   | 10 1/4  |                            | MSE1012 |                  |                |                 |      |                  |                 |                   |                                                                        |                                                                            | MSE1012 |                  |            |             |             |
| 300<br>305        | 10 3/4  | MSM300<br>MSM305           | MSE1100 | 1587<br>356772   | 2644<br>594395 | 129.00<br>29000 | 610  | 495.30<br>19.500 | 103.20<br>4.063 | 193.00<br>7.598   | MS38                                                                   | MSM300<br>MSM305                                                           | MSE1100 | 552.50<br>21.752 | 128<br>5.0 | 268<br>10.6 | 306<br>12.0 |
|                   | 11 1/2  |                            | MSE1200 |                  |                |                 |      |                  |                 |                   |                                                                        |                                                                            | MSE1200 |                  |            |             |             |
| 320<br>330        | 11 3/4  | MSM320<br>MSM330           | MSE1208 | 1723<br>387346   | 2922<br>656892 | 144.20<br>32417 | 550  | 527.05<br>20.750 | 106.40<br>4.189 | 192.00<br>7.559   | MS39                                                                   | MSM320<br>MSM330                                                           | MSE1208 | 587.40<br>23.126 | 128<br>5.0 | 298<br>11.7 | -           |
|                   | 12 1/2  |                            | MSE1300 |                  |                |                 |      |                  |                 |                   |                                                                        |                                                                            | MSE1300 |                  |            |             |             |
| 340<br>350<br>360 | 12 3/4  | MSM340<br>MSM350<br>MSM360 | MSE1400 | 1989<br>447145   | 3403<br>765025 | 159.20<br>35790 | 500  | 565.15<br>22.250 | 115.90<br>4.563 | 200.00<br>7.874   | MS40                                                                   | MSM340<br>MSM350<br>MSM360                                                 | MSE1400 | 628.70<br>24.752 | 146<br>5.7 | 305<br>12.0 | -           |
|                   | 14      |                            |         |                  |                |                 |      |                  |                 |                   |                                                                        |                                                                            |         |                  |            |             |             |

For triple labyrinth seal designations, please refer to page 32-34.



# MEDIUM SERIES SUPPORT

## S32 - S40

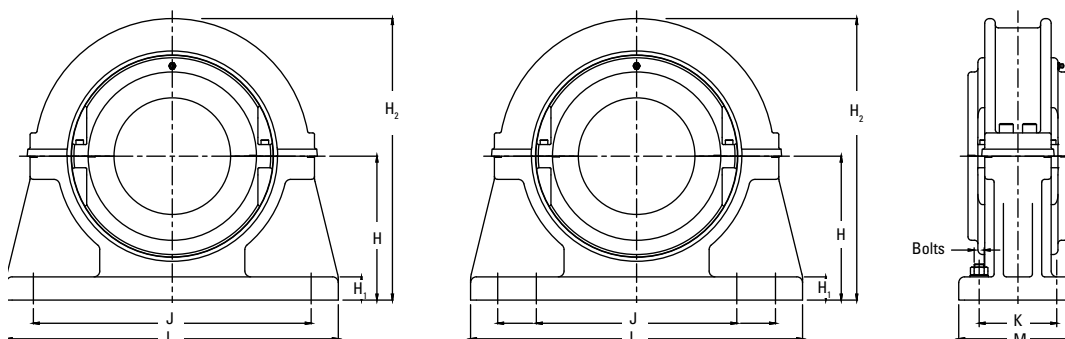

| Shaft (d)         |                                  | Support Reference | H             | H <sub>1</sub> | H <sub>2</sub> | J x K                               | L x M                   | Bolts   |
|-------------------|----------------------------------|-------------------|---------------|----------------|----------------|-------------------------------------|-------------------------|---------|
| mm                | in.                              |                   |               |                |                |                                     |                         |         |
| 160<br>170        | 6 7/16<br>6 1/2                  | S32               | 267<br>10.512 | 44<br>1.7      | 535<br>21.1    | 448 x 172<br>17.6 x 6.8             | 596 x 242<br>23.5 x 9.5 | 4 x M30 |
| 175<br>180        | 6 11/16<br>6 3/4<br>6 15/16<br>7 | S33               | 273<br>10.748 | 44<br>1.7      | 545<br>21.5    | 458 x 166<br>18 x 6.5               | 636 x 242<br>25 x 9.5   | 4 x M30 |
| 190<br>200        | 7 1/4<br>7 1/2<br>7 15/16<br>8   | S34               | 305<br>12.008 | 50<br>2.0      | 610<br>24.0    | 508 x 190<br>20 x 7.5               | 686 x 266<br>27 x 10.5  | 4 x M30 |
| 220<br>230        | 8 1/2<br>8 7/8<br>9              | S35               | 324<br>12.756 | 50<br>2.0      | 650<br>25.6    | 550 x 190<br>21.7 x 7.5             | 750 x 280<br>29.5 x 11  | 4 x M30 |
| 240<br>250<br>260 | 9 1/2<br>9 3/4<br>10             | S36               | 356<br>14.016 | 54<br>2.1      | 710<br>28.0    | 596 x 204<br>23.5 x 8               | 812 x 292<br>32 x 11.5  | 4 x M36 |
| 270<br>280        | 10 1/2<br>10 3/4<br>11           | S37               | 378<br>14.882 | 60<br>2.4      | 760<br>29.9    | 736 & 534 x 254<br>29 & 21 x 10     | 914 x 330<br>36 x 13    | 8 x M30 |
| 300<br>305        | 11 1/2<br>12                     | S38               | 394<br>15.512 | 60<br>2.4      | 790<br>31.1    | 768 & 566 x 254<br>30.2 & 22.3 x 10 | 958 x 330<br>37.7 x 13  | 8 x M30 |
| 320<br>330        | 12 1/2<br>13                     | S39               | 419<br>16.496 | 64<br>2.5      | 840<br>33.1    | 812 & 610 x 210<br>32 & 24 x 8.3    | 1016 x 292<br>40 x 11.5 | 8 x M30 |
| 340<br>350<br>360 | 14                               | S40               | 451<br>17.756 | 67<br>2.6      | 900<br>35.4    | 864 & 660 x 280<br>34 & 26 x 11     | 1092 x 368<br>43 x 14.5 | 8 x M36 |

# MEDIUM SERIES BEARING AND HOUSING

## 380 MM TO 600 MM (15 IN. TO 24 IN.)

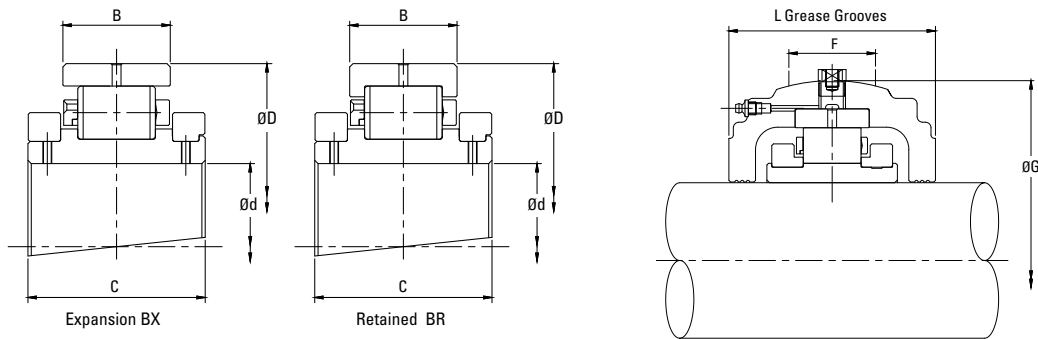

| Shaft (d)                                                            |                                                                          | Reference                                                             |         | Bearings Ratings       |                        |                      |        |                  |                 | Housing Reference |           |                  |                  |                  |            |             |   |
|----------------------------------------------------------------------|--------------------------------------------------------------------------|-----------------------------------------------------------------------|---------|------------------------|------------------------|----------------------|--------|------------------|-----------------|-------------------|-----------|------------------|------------------|------------------|------------|-------------|---|
|                                                                      |                                                                          |                                                                       |         | Dynamic C <sub>r</sub> | Static C <sub>0r</sub> | Axial C <sub>a</sub> | Max    | D                | B               | C                 | ATL Seals |                  | Other Seal Types |                  | G          | F           | L |
| Add <b>BR</b> for Retained Add <b>BX</b> for Expansion e.g. MS1700BR | Add <b>HRTL</b> for Retained Add <b>HXTL</b> for Expansion e.g. MS34HRTL | Add <b>HR</b> for Retained Add <b>HX</b> for Expansion e.g. MSE1700HR |         |                        |                        |                      |        |                  |                 |                   |           |                  |                  |                  |            |             |   |
| mm                                                                   | in.                                                                      |                                                                       | kN lb.  | kN lb.                 | kN lb.                 | RPM                  | mm in. | mm in.           | mm in.          |                   |           | mm in.           | mm in.           | mm in.           | mm in.     |             |   |
| 380                                                                  | 15                                                                       | MSM380                                                                | MSE1500 | 1931<br>434106         | 3522<br>791778         | 174.40<br>39207      | 460    | 584.20<br>23.000 | 111.10<br>4.374 | 200.00<br>7.874   | MS41      | MSM360<br>MSM380 | MSE1500          | 647.70<br>25.500 | 146<br>5.7 | 305<br>12.0 | – |
| 400                                                                  | 16                                                                       | MSM400                                                                | MSE1600 | 2105<br>473223         | 3793<br>852701         | 188.40<br>42354      | 430    | 615.95<br>24.250 | 115.90<br>4.563 | 200.00<br>7.874   | MS42      | MSM400           | MSE1600          | 685.80<br>27.000 | 146<br>5.7 | 324<br>12.8 | – |
| 420                                                                  | 17                                                                       | MSM420                                                                | MSE1700 | 2324<br>522456         | 4164<br>936105         | 202.00<br>45411      | 400    | 647.70<br>25.500 | 119.10<br>4.689 | 200.00<br>7.874   | MS43      | MSM420           | MSE1700          | 717.60<br>28.252 | 146<br>5.7 | 350<br>13.8 | – |
| 440<br>460                                                           | 18                                                                       | MSM440<br>MSM460                                                      | MSE1800 | 2215<br>497952         | 4183<br>940376         | 216.00<br>48559      | 380    | 666.75<br>26.250 | 115.90<br>4.563 | 200.00<br>7.874   | MS44      | MSM440<br>MSM460 | MSE1800          | 733.40<br>28.874 | 146<br>5.7 | 350<br>13.8 | – |
| 480                                                                  | 19                                                                       | MSM480                                                                | MSE1900 | 2445<br>549658         | 4594<br>1032773        | 230.00<br>51706      | 360    | 698.50<br>27.500 | 119.10<br>4.689 | 223.00<br>8.780   | MS45      | MSM480           | MSE1900          | 762.00<br>30.000 | 146<br>5.7 | 368<br>14.5 | – |
| 500                                                                  | 20                                                                       | MSM500                                                                | MSE2000 | 2453<br>551456         | 5054<br>1137229        | 244.00<br>54853      | 340    | 717.55<br>28.250 | 115.90<br>4.563 | 226.00<br>8.898   | MS46      | MSM500           | MSE2000          | 787.40<br>31.000 | 146<br>5.7 | 368<br>14.5 | – |
| 530                                                                  | 21                                                                       | MSM530                                                                | MSE2100 | 2702<br>607434         | 5467<br>1230020        | 258.00<br>58001      | 330    | 762.00<br>30.000 | 119.10<br>4.689 | 229.00<br>9.016   | MS47      | MSM530           | MSE2100          | 831.90<br>32.752 | 150<br>5.9 | 368<br>14.5 | – |
| 560                                                                  | 22                                                                       | MSM560                                                                | MSE2200 | 2851<br>640930         | 5794<br>1303567        | 272.00<br>61148      | 310    | 793.75<br>31.250 | 122.20<br>4.811 | 233.00<br>9.173   | MS48      | MSM560           | MSE2200          | 866.80<br>34.126 | 152<br>6.0 | 374<br>14.7 | – |
| 580                                                                  | 23                                                                       | MSM580                                                                | MSE2300 | 2982<br>670380         | 6231<br>1402056        | 286.00<br>64295      | 300    | 812.80<br>32.000 | 119.10<br>4.689 | 232.00<br>9.134   | MS49      | MSM580           | MSE2300          | 883.00<br>34.764 | 152<br>6.0 | 374<br>14.7 | – |
| 600                                                                  | 24                                                                       | MSM600                                                                | MSE2400 | 2972<br>668132         | 6243<br>1404650        | 300.00<br>67443      | 290    | 838.20<br>33.000 | 119.10<br>4.689 | 214.00<br>8.425   | MS50      | MSM600           | MSE2400          | 914.40<br>36.000 | 152<br>6.0 | 388<br>15.3 | – |

For triple labyrinth seal designations, please refer to page 32-34.

# MEDIUM SERIES SUPPORT

## S41 - S50

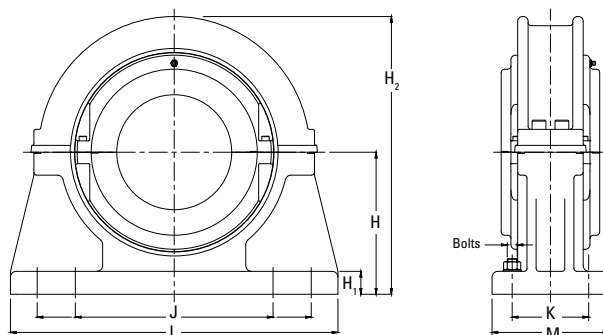

| Shaft (d)  |     | Support Reference | H             | H <sub>1</sub> | H <sub>2</sub> | J x K                                 | L x M                   | Bolts   |
|------------|-----|-------------------|---------------|----------------|----------------|---------------------------------------|-------------------------|---------|
| mm         | in. |                   | mm<br>in.     | mm<br>in.      | mm<br>in.      | mm<br>in.                             | mm<br>in.               |         |
| 380        | 15  | S41               | 464<br>18.268 | 67<br>2.6      | 925<br>36.4    | 886 & 682 x 280<br>34.9 & 26.9 x 11   | 1092 x 368<br>43 x 14.5 | 8 x M36 |
| 400        | 16  | S42               | 495<br>19.488 | 70<br>2.8      | 990<br>39.0    | 934 & 730 x 280<br>36.8 & 28.7 x 11   | 1168 x 368<br>46 x 14.5 | 8 x M36 |
| 420        | 17  | S43               | 514<br>20.236 | 70<br>2.8      | 1030<br>40.6   | 972 & 768 x 280<br>38.3 & 30.2 x 11   | 1194 x 368<br>47 x 14.5 | 8 x M36 |
| 440<br>460 | 18  | S44               | 533<br>20.984 | 73<br>2.9      | 1070<br>42.1   | 996 & 788 x 280<br>39.2 & 31 x 11     | 1244 x 368<br>49 x 14.5 | 8 x M36 |
| 480        | 19  | S45               | 552<br>21.732 | 76<br>3.0      | 1110<br>43.7   | 1042 & 812 x 280<br>41 & 32 x 11      | 1270 x 368<br>50 x 14.5 | 8 x M36 |
| 500        | 20  | S46               | 572<br>22.520 | 80<br>3.1      | 1145<br>45.1   | 1074 & 844 x 280<br>42.3 & 33.2 x 11  | 1296 x 368<br>51 x 14.5 | 8 x M36 |
| 530        | 21  | S47               | 594<br>23.386 | 83<br>3.3      | 1180<br>46.5   | 1118 & 890 x 280<br>44 & 35 x 11      | 1398 x 368<br>55 x 14.5 | 8 x M36 |
| 560        | 22  | S48               | 616<br>24.252 | 86<br>3.4      | 1230<br>48.4   | 1158 & 930 x 280<br>45.6 & 36.6 x 11  | 1422 x 382<br>56 x 15   | 8 x M42 |
| 580        | 23  | S49               | 635<br>25.000 | 89<br>3.5      | 1270<br>50.0   | 1187 & 959 x 280<br>46.7 & 37.8 x 11  | 1448 x 382<br>57 x 15   | 8 x M42 |
| 600        | 24  | S50               | 673<br>26.496 | 92<br>3.6      | 1345<br>53.0   | 1238 & 1010 x 280<br>48.7 & 39.8 x 11 | 1524 x 382<br>60 x 15   | 8 x M42 |

## **MEDIUM SERIES SUPPORT FLANGE UNITS 45 MM TO 305 MM (1 1/16 IN. TO 12 IN.)**

When faced with flat horizontal or vertical faces, flange units offer a simple mounting solution. As with pillow block supports, flange units are produced with spherical location to accommodate standard bearing housings and provide easy initial alignment of shaft and equipment.

To facilitate positive location of the flange to the surface, the rear face is recessed (dimensions N and V). This allows for a spigot (tolerance f8) to be located into the flange.

Bearing inspection is simply a matter of removing the top half of the

flange and housing. Bearing replacement also may be achieved in the same manner if required.

When integrating flange units into new applications, it should be noted that a maximum radial load equivalent to 0.26 C<sub>or</sub> is permissible. A maximum axial load of 0.25 C<sub>a</sub> also must be taken into account for applications with thrust loading. Units for vertically oriented shafts may also need special consideration given to sealing arrangements.

Contact a Timken engineer for any application issues.

| Shaft (d)         |                                    | Flange Reference | T           | Bolts   | R           | P         | H          | N                | V        | L          |
|-------------------|------------------------------------|------------------|-------------|---------|-------------|-----------|------------|------------------|----------|------------|
| mm                | in.                                |                  |             |         |             |           |            |                  |          |            |
| 45<br>50          | 1 11/16<br>1 3/4<br>1 15/16<br>2   | F03              | 260<br>10.2 | 4 x M12 | 218<br>8.6  | 16<br>0.6 | 67<br>2.6  | 166.9<br>6.571   | 3<br>0.1 | 124<br>4.9 |
| 55<br>60<br>65    | 2 3/16<br>2 1/4<br>2 7/16<br>2 1/2 | F04              | 286<br>11.3 | 4 x M12 | 242<br>9.5  | 16<br>0.6 | 73<br>2.9  | 192.09<br>7.563  | 3<br>0.1 | 136<br>5.4 |
| 70<br>75          | 2 11/16<br>2 3/4<br>2 15/16<br>3   | F05              | 330<br>13.0 | 4 x M16 | 274<br>10.8 | 19<br>0.7 | 79<br>3.1  | 215.9<br>8.500   | 3<br>0.1 | 150<br>5.9 |
| 80<br>85<br>90    | 3 3/16<br>3 1/4<br>3 7/16<br>3 1/2 | F06              | 356<br>14.0 | 4 x M16 | 302<br>11.9 | 19<br>0.7 | 86<br>3.4  | 244.47<br>9.625  | 3<br>0.1 | 164<br>6.5 |
| 100<br>105        | 3 11/16<br>3 3/4<br>3 15/16<br>4   | F07              | 382<br>15.0 | 4 x M16 | 334<br>13.1 | 22<br>0.9 | 92<br>3.6  | 276.22<br>10.875 | 3<br>0.1 | 166<br>6.5 |
| 110<br>115        | 4 3/16<br>4 1/4<br>4 7/16<br>4 1/2 | F08              | 432<br>17.0 | 4 x M24 | 374<br>14.7 | 22<br>0.9 | 98<br>3.9  | 314.32<br>12.375 | 3<br>0.1 | 180<br>7.1 |
| 120<br>125<br>130 | 4 11/16<br>4 3/4<br>4 15/16<br>5   | F10              | 470<br>18.5 | 4 x M24 | 412<br>16.2 | 25<br>1.0 | 114<br>4.5 | 346.07<br>13.625 | 3<br>0.1 | 206<br>8.1 |
| 135<br>140        | 5 3/16<br>5 1/4<br>5 7/16<br>5 1/2 | F30              | 508<br>20.0 | 4 x M24 | 444<br>17.5 | 25<br>1.0 | 114<br>4.5 | 377.82<br>14.875 | 3<br>0.1 | 208<br>8.2 |

For bearings and housings see pages 60, 62 and 64.

*continued on next page*

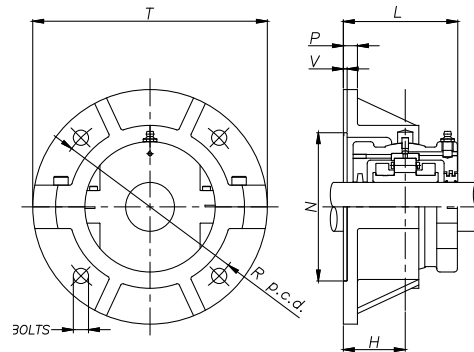

continued from previous page

| Shaft (d)          |                                  | Flange Reference | T           | Bolts   | R           | P         | H          | N                | V        | L           |
|--------------------|----------------------------------|------------------|-------------|---------|-------------|-----------|------------|------------------|----------|-------------|
| mm                 | in.                              |                  |             |         |             |           |            |                  |          |             |
| 150<br>155<br>160A | 5 1/16<br>5 3/4<br>5 15/16<br>6  | F31              | 534<br>21.0 | 4 x M24 | 466<br>18.3 | 25<br>1.0 | 124<br>4.9 | 393.70<br>15.500 | 3<br>0.1 | 226<br>8.9  |
| 160<br>170         | 6 7/16<br>6 1/2                  | F32              | 584<br>23.0 | 4 x M30 | 508<br>20.0 | 29<br>1.1 | 124<br>4.9 | 428.62<br>16.875 | 5<br>0.2 | 240<br>9.4  |
| 175<br>180         | 6 11/16<br>6 3/4<br>6 15/16<br>7 | F33              | 596<br>23.5 | 4 x M30 | 524<br>20.6 | 32<br>1.3 | 130<br>5.1 | 444.50<br>17.500 | 5<br>0.2 | 252<br>9.9  |
| 190<br>200         | 7 1/4<br>7 1/2<br>7 15/16<br>8   | F34              | 648<br>25.5 | 4 x M30 | 572<br>22.5 | 32<br>1.3 | 137<br>5.4 | 492.12<br>19.375 | 5<br>0.2 | 266<br>10.5 |
| 220<br>230         | 8 1/2<br>8 7/8<br>9              | F35              | 712<br>28.0 | 4 x M36 | 620<br>24.4 | 35<br>1.4 | 146<br>5.7 | 527.05<br>20.750 | 5<br>0.2 | 284<br>11.2 |
| 240<br>250<br>260  | 9 1/2<br>9 3/4<br>10             | F36              | 736<br>29.0 | 4 x M36 | 660<br>26.0 | 38<br>1.5 | 149<br>5.9 | 568.32<br>22.375 | 5<br>0.2 | 290<br>11.4 |
| 270<br>280         | 10 1/2<br>10 3/4<br>11           | F37              | 762<br>30.0 | 8 x M30 | 682<br>26.9 | 38<br>1.5 | 159<br>6.3 | 603.25<br>23.750 | 5<br>0.2 | 310<br>12.2 |
| 300<br>305         | 11 1/2<br>12                     | F38              | 788<br>31.0 | 8 x M30 | 708<br>27.9 | 41<br>1.6 | 162<br>6.4 | 628.65<br>24.750 | 5<br>0.2 | 316<br>12.4 |

**MEDIUM SERIES SUPPORT**

**TAKE-UP UNITS TT/TP 45 MM TO 155 MM (1 1/16 IN. TO 6 IN.)**

This type of split unit can be found in use on materials handling equipment in many industries. Take-up units provide an efficient and readily accessible means of tensioning conveyor systems and large scale drives.

The units consist of either push-type or pull-type sliding supports into which standard housings and bearings may

be mounted. When integrating take-up units into new applications, it should be noted that a maximum radial load equivalent to 0.3 C<sub>or</sub> is permissible. As with all Timken units, a wide variety of sealing solutions may be applied dependant on the environment and application. Please contact a Timken engineer for assistance.

| Shaft (d)                           |                                    | Support Reference |           | B                 | N                  | D                  | V                 | P                | H                | S                | A                 | T                  | X                | W                | R                | U               | Y                |
|-------------------------------------|------------------------------------|-------------------|-----------|-------------------|--------------------|--------------------|-------------------|------------------|------------------|------------------|-------------------|--------------------|------------------|------------------|------------------|-----------------|------------------|
|                                     |                                    | Tension-Type      | Push-Type |                   |                    |                    |                   |                  |                  |                  |                   |                    |                  |                  |                  |                 |                  |
| mm                                  | in.                                |                   |           | mm in.            | mm in.             | mm in.             | mm in.            | mm in.           | mm in.           | mm in.           | mm in.            | mm in.             | mm in.           | mm in.           | mm in.           | mm in.          | mm in.           |
| <b>45</b><br><b>50</b>              | 1 11/16<br>1 3/4<br>1 15/16<br>2   | TT03              | TP03      | <b>128</b><br>5.0 | <b>235</b><br>9.3  | <b>203</b><br>8.0  | <b>102</b><br>4.0 | <b>20</b><br>0.8 | <b>32</b><br>1.3 | <b>38</b><br>1.5 | <b>146</b><br>5.7 | <b>280</b><br>11.0 | <b>24</b><br>0.9 | <b>30</b><br>1.2 | <b>29</b><br>1.1 | <b>6</b><br>0.2 | <b>16</b><br>0.6 |
| <b>55</b><br><b>60</b><br><b>65</b> | 2 3/16<br>2 1/4<br>2 7/16<br>2 1/2 | TT04              | TP04      | <b>152</b><br>6.0 | <b>266</b><br>10.5 | <b>229</b><br>9.0  | <b>114</b><br>4.5 | <b>22</b><br>0.9 | <b>40</b><br>1.6 | <b>41</b><br>1.6 | <b>158</b><br>6.2 | <b>305</b><br>12.0 | <b>24</b><br>0.9 | <b>30</b><br>1.2 | <b>32</b><br>1.3 | <b>6</b><br>0.2 | <b>16</b><br>0.6 |
| <b>70</b><br><b>75</b>              | 2 11/16<br>2 3/4<br>2 15/16<br>3   | TT05              | TP05      | <b>190</b><br>7.5 | <b>318</b><br>12.5 | <b>280</b><br>11.0 | <b>140</b><br>5.5 | <b>22</b><br>0.9 | <b>40</b><br>1.6 | <b>51</b><br>2.0 | <b>190</b><br>7.5 | <b>368</b><br>14.5 | <b>30</b><br>1.2 | <b>38</b><br>1.5 | <b>35</b><br>1.4 | <b>6</b><br>0.2 | <b>16</b><br>0.6 |
| <b>80</b><br><b>85</b><br><b>90</b> | 3 3/16<br>3 1/4<br>3 7/16<br>3 1/2 | TT06              | TP06      | <b>204</b><br>8.0 | <b>342</b><br>13.5 | <b>305</b><br>12.0 | <b>152</b><br>6.0 | <b>22</b><br>0.9 | <b>43</b><br>1.7 | <b>51</b><br>2.0 | <b>210</b><br>8.3 | <b>414</b><br>16.3 | <b>36</b><br>1.4 | <b>44</b><br>1.7 | <b>35</b><br>1.4 | <b>6</b><br>0.2 | <b>19</b><br>0.7 |
| <b>100</b><br><b>105</b>            | 3 11/16<br>3 3/4<br>3 15/16<br>4   | TT07              | TP07      | <b>216</b><br>8.5 | <b>382</b><br>15.0 | <b>343</b><br>13.5 | <b>162</b><br>6.4 | <b>22</b><br>0.9 | <b>48</b><br>1.9 | <b>70</b><br>2.8 | <b>228</b><br>9.0 | <b>445</b><br>17.5 | <b>42</b><br>1.7 | <b>44</b><br>1.7 | <b>41</b><br>1.6 | <b>6</b><br>0.2 | <b>19</b><br>0.7 |

For bearings and housings see pages 60, 62 and 64.

*continued on next page*

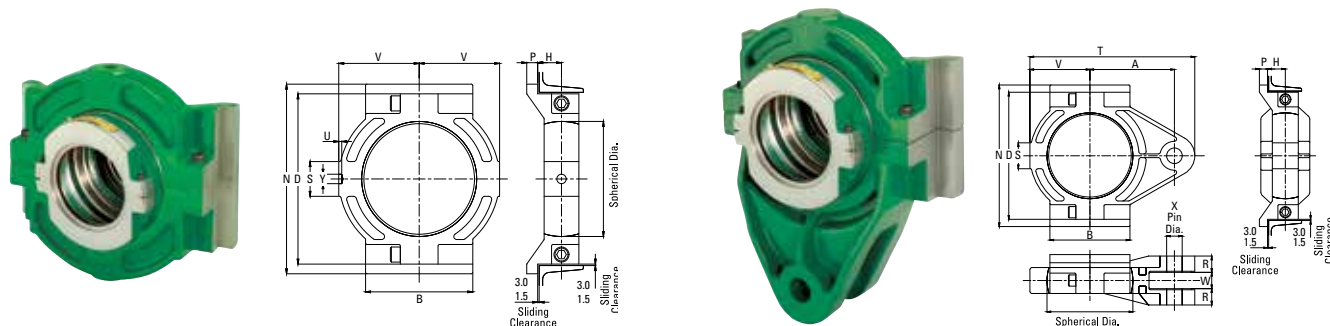

continued from previous page

| Shaft (d)                              |                                    | Support Reference |           | B                  | N                  | D                  | V                 | P                | H                | S                | A                  | T                  | X                | W                | R                | U                | Y                |
|----------------------------------------|------------------------------------|-------------------|-----------|--------------------|--------------------|--------------------|-------------------|------------------|------------------|------------------|--------------------|--------------------|------------------|------------------|------------------|------------------|------------------|
|                                        |                                    | Tension-Type      | Push-Type |                    |                    |                    |                   |                  |                  |                  |                    |                    |                  |                  |                  |                  |                  |
| mm                                     | in.                                |                   |           | mm<br>in.          | mm<br>in.          | mm<br>in.          | mm<br>in.         | mm<br>in.        | mm<br>in.        | mm<br>in.        | mm<br>in.          | mm<br>in.          | mm<br>in.        | mm<br>in.        | mm<br>in.        | mm<br>in.        | mm<br>in.        |
| <b>110</b><br><b>115</b>               | 4 3/16<br>4 1/4<br>4 7/16<br>4 1/2 | TT08              | TP08      | <b>254</b><br>10.0 | <b>420</b><br>16.5 | <b>381</b><br>15.0 | <b>190</b><br>7.5 | <b>25</b><br>1.0 | <b>51</b><br>2.0 | <b>76</b><br>3.0 | <b>260</b><br>10.2 | <b>508</b><br>20.0 | <b>42</b><br>1.7 | <b>44</b><br>1.7 | <b>44</b><br>1.7 | <b>6</b><br>0.2  | <b>19</b><br>0.7 |
| <b>120</b><br><b>125</b><br><b>130</b> | 4 11/16<br>4 3/4<br>4 15/16<br>5   | TT10              | TP10      | <b>266</b><br>10.5 | <b>464</b><br>18.3 | <b>426</b><br>16.8 | <b>204</b><br>8.0 | <b>25</b><br>1.0 | <b>57</b><br>2.2 | <b>86</b><br>3.4 | <b>280</b><br>11.0 | <b>546</b><br>21.5 | <b>48</b><br>1.9 | <b>50</b><br>2.0 | <b>51</b><br>2.0 | <b>8</b><br>0.3  | <b>23</b><br>0.9 |
| <b>135</b><br><b>140</b>               | 5 3/16<br>5 1/4<br>5 7/16<br>5 1/2 | TT30              | TP30      | <b>280</b><br>11.0 | <b>502</b><br>19.8 | <b>464</b><br>18.3 | <b>222</b><br>8.7 | <b>25</b><br>1.0 | <b>60</b><br>2.4 | <b>92</b><br>3.6 | <b>298</b><br>11.7 | <b>584</b><br>23.0 | <b>48</b><br>1.9 | <b>50</b><br>2.0 | <b>54</b><br>2.1 | <b>8</b><br>0.3  | <b>23</b><br>0.9 |
| <b>150</b><br><b>155</b><br><b>160</b> | 5 11/16<br>5 3/4<br>5 15/16<br>6   | TT31              | TP31      | <b>305</b><br>12.0 | <b>528</b><br>20.8 | <b>489</b><br>19.3 | <b>235</b><br>9.3 | <b>25</b><br>1.0 | <b>64</b><br>2.5 | <b>92</b><br>3.6 | <b>312</b><br>12.3 | <b>616</b><br>24.3 | <b>48</b><br>1.9 | <b>50</b><br>2.0 | <b>57</b><br>2.2 | <b>10</b><br>0.4 | <b>26</b><br>1.0 |





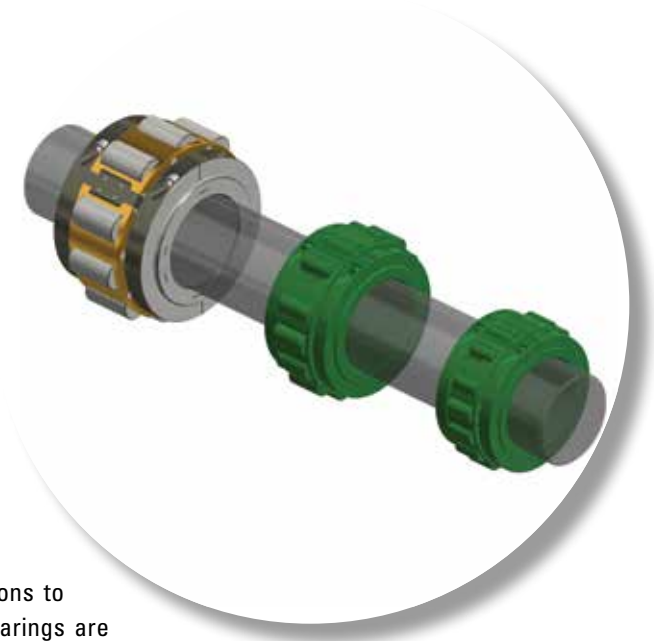

## **HEAVY SERIES**

Heavy series bearing products offer solutions to the most demanding of load conditions. Bearings are supported by robust and durable mountings and can be equipped with a variety of sealing solutions. If a standard catalog product does not meet your requirements, a Timken engineer will be happy to provide help and advice on your application.

The following topics are covered within this section:

|                                                                             |    |
|-----------------------------------------------------------------------------|----|
| Heavy Series Bearing and Housing<br>100 mm to 260 mm (3 1/8 in. to 10 in.)  | 72 |
| Heavy Series Support S54 - S63                                              | 73 |
| Heavy Series Bearing and Housing<br>280 mm to 600 mm (11 in. to 24 in.)     | 74 |
| Heavy Series Support S83 - S95                                              | 75 |
| Heavy Series Support Flange Units<br>125 mm to 260 mm (4 1/8 in. to 10 in.) | 76 |

# HEAVY SERIES BEARING AND HOUSING

## 100 MM TO 260 MM (3 1/16 IN. TO 10 IN.)

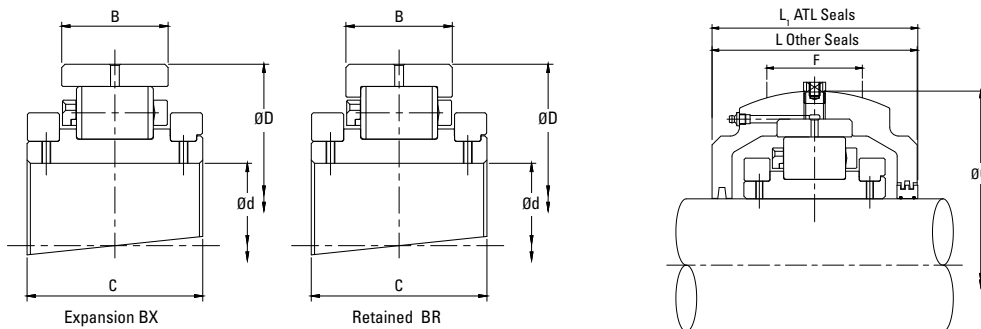

| Shaft (d)  |                                 | Reference        |                                      | Bearings Ratings       |                        |                      |      |                  |                                    |                 | Housing Reference |                  |                                      |                  |            |             |             |
|------------|---------------------------------|------------------|--------------------------------------|------------------------|------------------------|----------------------|------|------------------|------------------------------------|-----------------|-------------------|------------------|--------------------------------------|------------------|------------|-------------|-------------|
|            |                                 |                  |                                      | Dynamic C <sub>r</sub> | Static C <sub>0r</sub> | Axial C <sub>a</sub> | Max  | D                | B, B <sub>1</sub>                  | C               | ATL Seals         |                  | Other Seal Types                     |                  | G          | F           | L           |
| mm         | in.                             | kN lb.           | kN lb.                               |                        |                        |                      |      |                  |                                    |                 | kN lb.            | RPM              | mm in.                               | mm in.           |            |             |             |
| 100<br>105 | 3 1/16<br>3 3/4<br>3 15/16<br>4 | HSM100<br>HSM105 | HSE311<br>HSE312<br>HSE315<br>HSE400 | 653<br>146800          | 783<br>176025          | 31.20<br>7014        | 1820 | 254.00<br>10.000 | 84.20<br>3.315                     | 136.00<br>5.354 | HS54              | HSM100<br>HSM105 | HSE311<br>HSE312<br>HSE315<br>HSE400 | 308.00<br>12.126 | 95<br>3.7  | 200<br>7.9  | 206<br>8.1  |
|            | 110<br>115<br>120               |                  |                                      |                        |                        |                      |      |                  |                                    |                 |                   |                  |                                      |                  |            |             |             |
| 125<br>130 | 4 1/16<br>4 3/4<br>4 15/16<br>5 | HSM125<br>HSM130 | HSE411<br>HSE412<br>HSE415<br>HSE500 | 753<br>169281          | 974<br>218964          | 49.00<br>11016       | 1500 | 279.40<br>11.000 | 73.10<br>2.878                     | 140.00<br>5.512 | HS56              | HSM125<br>HSM130 | HSE415<br>HSE500                     | 323.85<br>12.750 | 102<br>4.0 | 214<br>8.4  | 222<br>8.7  |
|            | 135<br>140                      |                  |                                      |                        |                        |                      |      |                  | 5 3/16<br>5 1/4<br>5 7/16<br>5 1/2 |                 |                   |                  |                                      |                  |            |             |             |
| 150<br>155 | 5 1/16<br>5 3/4<br>5 15/16<br>6 | HSM150<br>HSM155 | HSE511<br>HSE512<br>HSE515<br>HSE600 | 1037<br>233127         | 1325<br>297872         | 69.40<br>15602       | 1220 | 330.20<br>13.000 | 81.00<br>3.189                     | 160.00<br>6.299 | HS58              | HSM150<br>HSM155 | HSE511<br>HSE512<br>HSE515<br>HSE600 | 393.70<br>15.500 | 114<br>4.5 | 232<br>9.1  | 254<br>10.0 |
|            | 160<br>170                      |                  |                                      |                        |                        |                      |      |                  | 6 7/16<br>6 1/2<br>6 11/16         |                 |                   |                  |                                      |                  |            |             |             |
| 175<br>180 | 6 3/4<br>6 15/16<br>7           | HSM175<br>HSM180 | HSE612<br>HSE615<br>HSE700           | 1330<br>298996         | 1867<br>419718         | 89.00<br>20008       | 1030 | 374.65<br>14.750 | 92.10<br>3.626                     | 178.00<br>7.008 | HS60              | HSM175<br>HSM180 | HSE612<br>HSE615<br>HSE700           | 431.80<br>17.000 | 132<br>5.2 | 254<br>10.0 | 284<br>11.2 |
|            | 190<br>200                      |                  |                                      |                        |                        |                      |      |                  | 7 1/4<br>7 1/2<br>7 15/16<br>8     |                 |                   |                  |                                      |                  |            |             |             |
| 220<br>230 | 8 1/2<br>8 7/8<br>9             | HSM220<br>HSM230 | HSE808<br>HSE814<br>HSE900           | 1665<br>374307         | 2455<br>551906         | 109.40<br>24594      | 760  | 469.90<br>18.500 | 109.60<br>4.315                    | 212.00<br>8.346 | HS62              | HSM220<br>HSM230 | HSE808<br>HSE814<br>HSE900           | 546.10<br>21.500 | 165<br>6.5 | 298<br>11.7 | 334<br>13.1 |
|            | 240<br>260                      |                  |                                      |                        |                        |                      |      |                  | 9 1/2<br>9 3/4<br>10               |                 |                   |                  |                                      |                  |            |             |             |

For triple labyrinth seal designations, please refer to page 32-34.

# HEAVY SERIES SUPPORT

## S54 - S63

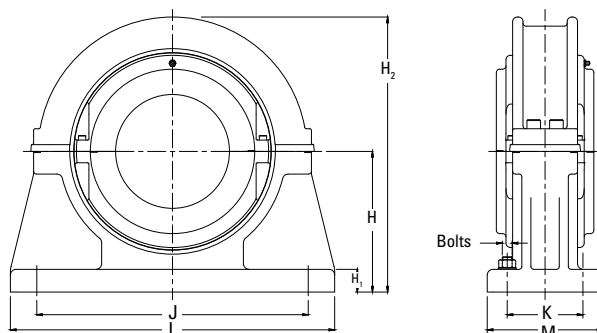

| Shaft (d)                              |                                    | Support Reference | H                    | H <sub>1</sub>   | H <sub>2</sub>     | J x K                          | L x M                          | Bolts   |
|----------------------------------------|------------------------------------|-------------------|----------------------|------------------|--------------------|--------------------------------|--------------------------------|---------|
| mm                                     | in.                                |                   | mm in.               | mm in.           | mm in.             | mm in.                         | mm in.                         |         |
| <b>100</b><br><b>105</b>               | 3 11/16<br>3 3/4<br>3 15/16<br>4   | S54               | <b>191</b><br>7.520  | <b>38</b><br>1.5 | <b>405</b><br>15.9 | <b>438 x 82</b><br>17.2 x 3.2  | <b>514 x 152</b><br>20.2 x 6   | 4 x M24 |
| <b>110</b><br><b>115</b><br><b>120</b> | 4 3/16<br>4 1/4<br>4 7/16<br>4 1/2 | S55               | <b>197</b><br>7.756  | <b>38</b><br>1.5 | <b>425</b><br>16.7 | <b>458 x 88</b><br>18 x 3.5    | <b>534 x 166</b><br>21 x 6.5   | 4 x M24 |
| <b>125</b><br><b>130</b>               | 4 15/16<br>5                       | S56               | <b>203</b><br>7.992  | <b>48</b><br>1.9 | <b>435</b><br>17.1 | <b>470 x 96</b><br>18.5 x 3.8  | <b>546 x 166</b><br>21.5 x 6.5 | 4 x M24 |
| <b>135</b><br><b>140</b>               | 5 3/16<br>5 1/4<br>5 7/16<br>5 1/2 | S57               | <b>229</b><br>9.016  | <b>54</b><br>2.1 | <b>485</b><br>19.1 | <b>514 x 102</b><br>20.2 x 4   | <b>622 x 178</b><br>24.5 x 7   | 4 x M30 |
| <b>150</b><br><b>155</b>               | 5 11/16<br>5 3/4<br>5 15/16<br>6   | S58               | <b>254</b><br>10.000 | <b>57</b><br>2.2 | <b>535</b><br>21.1 | <b>558 x 120</b><br>22 x 4.7   | <b>666 x 204</b><br>26.2 x 8   | 4 x M30 |
| <b>160</b><br><b>170</b>               | 6 7/16<br>6 1/2<br>6 11/16         | S59               | <b>267</b><br>10.512 | <b>60</b><br>2.4 | <b>570</b><br>22.4 | <b>628 x 140</b><br>24.7 x 5.5 | <b>736 x 228</b><br>29 x 9     | 4 x M30 |
| <b>175</b><br><b>180</b>               | 6 3/4<br>6 15/16<br>7              | S60               | <b>279</b><br>10.984 | <b>64</b><br>2.5 | <b>580</b><br>22.8 | <b>636 x 152</b><br>25 x 6     | <b>762 x 254</b><br>30 x 10    | 4 x M30 |
| <b>190</b><br><b>200</b>               | 7 1/4<br>7 1/2<br>7 15/16<br>8     | S61               | <b>311</b><br>12.244 | <b>67</b><br>2.6 | <b>655</b><br>25.8 | <b>636 x 172</b><br>25 x 6.8   | <b>838 x 266</b><br>33 x 10.5  | 4 x M36 |
| <b>220</b><br><b>230</b>               | 8 1/2<br>8 5/8<br>9                | S62               | <b>349</b><br>13.740 | <b>76</b><br>3.0 | <b>730</b><br>28.7 | <b>736 x 178</b><br>29 x 7     | <b>952 x 280</b><br>37.5 x 11  | 4 x M42 |
| <b>240</b><br><b>260</b>               | 9 1/2<br>9 1/4<br>10               | S63               | <b>394</b><br>15.512 | <b>76</b><br>3.0 | <b>790</b><br>31.1 | <b>670 x 304</b><br>26.4 x 12  | <b>914 x 406</b><br>36 x 16    | 4 x M42 |

# HEAVY SERIES BEARING AND HOUSING

## 280 MM TO 600 MM (11 IN. TO 24 IN.)

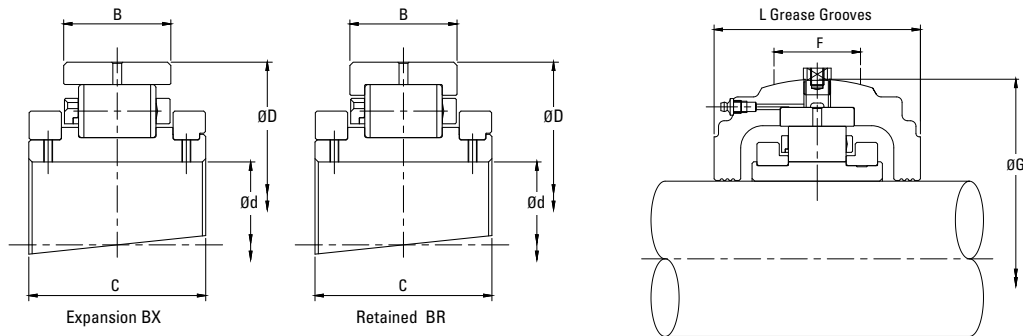

| Shaft (d)                                               |          | Reference                                                  |                 | Bearings Ratings       |                        |                      |                  |                 |                   | Housing Reference |                                                         |                  |                  |             |             |   |
|---------------------------------------------------------|----------|------------------------------------------------------------|-----------------|------------------------|------------------------|----------------------|------------------|-----------------|-------------------|-------------------|---------------------------------------------------------|------------------|------------------|-------------|-------------|---|
|                                                         |          |                                                            |                 | Dynamic C <sub>r</sub> | Static C <sub>or</sub> | Axial C <sub>a</sub> | Max              | D               | B, B <sub>1</sub> | C                 | ATL Seals                                               |                  | Other Seal Types |             | G           | F |
| Add BR for Retained Add BX for Expansion e.g. HSE1700BR |          | Add HRTL for retained Add HXTL for expansion e.g. HS89HRTL |                 |                        |                        |                      |                  |                 |                   |                   | Add HR for Retained Add HX for Expansion e.g. HSE1700HR |                  |                  |             |             |   |
| mm                                                      | in.      |                                                            |                 |                        |                        |                      |                  |                 |                   |                   |                                                         |                  |                  |             |             |   |
|                                                         |          | kN lb.                                                     | kN lb.          | kN lb.                 | RPM                    | mm in.               | mm in.           | mm in.          |                   |                   |                                                         | mm in.           | mm in.           | mm in.      | mm in.      |   |
| 280                                                     | 11       | HSM280<br>HSE1100                                          | 2202<br>495029  | 3507<br>788405         | 153.00<br>34396        | 620                  | 495.30<br>19.500 | 139.70<br>5.500 | 244.00<br>9.606   | HS83              | HSM280<br>HSE1100                                       | 571.50<br>22.500 | 165<br>6.5       | 356<br>14.0 | 356<br>14.0 |   |
| 300                                                     | 12       | HSM300<br>HSE1200                                          | 2337<br>525379  | 3650<br>820553         | 174.40<br>39207        | 560                  | 558.80<br>22.000 | 139.70<br>5.500 | 244.00<br>9.606   | HS65              | HSM300<br>HSE1200                                       | 641.40<br>25.252 | 165<br>6.5       | 346<br>13.6 | 370<br>14.6 |   |
| 320                                                     | 13       | HSM320<br>HSE1300                                          | 2718<br>611031  | 4093<br>920143         | 198.80<br>44692        | 500                  | 622.30<br>24.500 | 160.40<br>6.315 | 272.00<br>10.709  | HS66              | HSM320<br>HSE1300                                       | 717.60<br>28.252 | 170<br>6.7       | 368<br>14.5 | —           |   |
| 340<br>360                                              | 14       | HSM340<br>HSM360<br>HSE1400                                | 2935<br>659814  | 4973<br>1117975        | 213.60<br>48019        | 460                  | 615.95<br>24.250 | 158.00<br>6.220 | 279.00<br>10.984  | HS86              | HSM340<br>HSM360<br>HSE1400                             | 704.90<br>27.752 | 196<br>7.7       | 432<br>17.0 | —           |   |
| 380<br>400                                              | 15<br>16 | HSM380<br>HSM400<br>HSE1500<br>HSE1600                     | 3195<br>718265  | 5238<br>1177550        | 250.80<br>56382        | 420                  | 685.80<br>27.000 | 166.70<br>6.563 | 292.00<br>11.496  | HS68<br>HS68E0548 | HSM380<br>HSM400<br>HSE1500<br>HSE1600                  | 774.70<br>30.500 | 202<br>8.0       | 400<br>15.7 | —           |   |
| 420<br>440                                              | 17       | HSM420<br>HSM440<br>HSE1700                                | 3582<br>805266  | 6377<br>1433607        | 275.80<br>62002        | 360                  | 700.00<br>27.559 | 160.00<br>6.299 | 284.00<br>11.181  | HS89              | HSM420<br>HSM440<br>HSE1700                             | 788.00<br>31.024 | 200<br>7.9       | 440<br>17.3 | —           |   |
| 460                                                     | 18       | HSM460<br>HSE1800                                          | 3807<br>855848  | 6611<br>1486212        | 302.40<br>67982        | 340                  | 740.00<br>29.134 | 170.00<br>6.693 | 294.00<br>11.575  | HS90              | HSM460<br>HSE1800                                       | 840.00<br>33.071 | 200<br>7.9       | 450<br>17.7 | —           |   |
| 500<br>530                                              | 20<br>21 | HSM500<br>HSM530<br>HSE2000<br>HSE2100                     | 4660<br>1047610 | 8183<br>1839612        | 347.00<br>78009        | 310                  | 850.90<br>33.500 | 187.40<br>7.378 | 300.00<br>11.811  | HS94<br>HS94E0548 | HSM500<br>HSM530<br>HSE2000<br>HSE2100                  | 958.90<br>37.752 | 204<br>8.0       | 495<br>19.5 | —           |   |
| 560                                                     | 22       | HSM560<br>HSE2200                                          | 4795<br>1077959 | 9412<br>2115902        | 382.60<br>86012        | 280                  | 863.60<br>34.000 | 196.90<br>7.752 | 310.00<br>12.205  | HS94              | HSM560<br>HSE2200                                       | 958.90<br>37.752 | 204<br>8.0       | 490<br>19.3 | —           |   |
| 580<br>600                                              | 23<br>24 | HSM580<br>HSM600<br>HSE2300<br>HSE2400                     | 4951<br>1113029 | 9451<br>2124669        | 400<br>89924           | 270                  | 890.00<br>35.039 | 184.00<br>7.244 | 310.00<br>12.205  | HS95              | HSM580<br>HSM600<br>HSE2300<br>HSE2400                  | 990.00<br>38.976 | 204<br>8.0       | 490<br>19.3 | —           |   |

# HEAVY SERIES SUPPORT

## S83 - S95

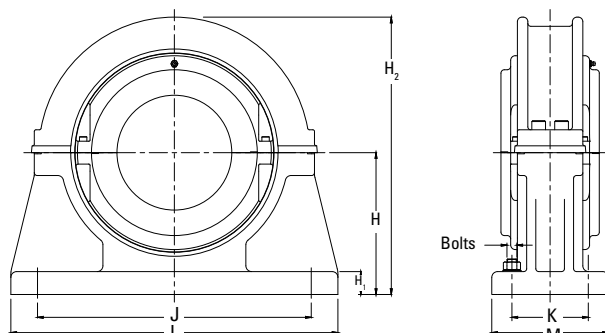

| Shaft (d)  |          | Support Reference | H             | H <sub>1</sub> | H <sub>2</sub> | J x K                                  | L x M                   | Bolts   |
|------------|----------|-------------------|---------------|----------------|----------------|----------------------------------------|-------------------------|---------|
| mm         | in.      |                   | mm<br>in.     | mm<br>in.      | mm<br>in.      | mm<br>in.                              | mm<br>in.               |         |
| 280        | 11       | S83               | 368<br>14.488 | 70<br>2.8      | 785<br>30.9    | 742 & 502 x 178<br>29.2 & 19.8 x 7     | 940 x 280<br>37 x 11    | 8 x M36 |
| 300        | 12       | S65               | 457<br>17.992 | 76<br>3.0      | 915<br>36.0    | 876 & 674 x 330<br>34.5 & 26.5 x 13    | 1092 x 420<br>43 x 16.5 | 8 x M36 |
| 320        | 13       | S66               | 518<br>20.394 | 80<br>3.1      | 1035<br>40.7   | 978 & 762 x 266<br>38.5 & 30 x 10.5    | 1194 x 356<br>47 x 14   | 8 x M36 |
| 340<br>360 | 14       | S86               | 470<br>18.504 | 82<br>3.2      | 1000<br>39.4   | 928 & 660 x 190<br>36.5 & 26 x 7.5     | 1220 x 318<br>48 x 12.5 | 8 x M42 |
| 380<br>400 | 15<br>16 | S68               | 559<br>22.008 | 92<br>3.6      | 1120<br>44.1   | 1036 & 806 x 292<br>40.8 & 31.7 x 11.5 | 1270 x 394<br>50 x 15.5 | 8 x M42 |
| 420<br>440 | 17       | S89               | 508<br>20.000 | 90<br>3.5      | 1075<br>42.3   | 990 & 690 x 210<br>39 & 27.2 x 8.3     | 1270 x 360<br>50 x 14.2 | 8 x M48 |
| 460        | 18       | S90               | 550<br>21.654 | 95<br>3.7      | 1165<br>45.9   | 1080 & 780 x 220<br>42.5 & 30.7 x 8.7  | 1370 x 380<br>53.9 x 15 | 8 x M48 |
| 500<br>530 | 20<br>21 | S94               | 622<br>24.488 | 102<br>4.0     | 1340<br>52.8   | 1270 & 940 x 242<br>50 & 37 x 9.5      | 1600 x 406<br>63 x 16   | 8 x M56 |
| 560        | 22       | S94               | 622<br>24.488 | 102<br>4.0     | 1340<br>52.8   | 1270 & 940 x 242<br>50 & 37 x 9.5      | 1600 x 406<br>63 x 16   | 8 x M56 |
| 580<br>600 | 23<br>24 | S95               | 622<br>24.488 | 102<br>4.0     | 1340<br>52.8   | 1270 & 940 x 242<br>50 & 37 x 9.5      | 1600 x 406<br>63 x 16   | 8 x M56 |

## HEAVY SERIES FLANGE UNITS 125 MM TO 260 MM (4 15/16 IN. TO 10 IN.)

When faced with flat horizontal or vertical faces, flange units offer a simple mounting solution. As with pillow block supports, flange units are produced with spherical location to accommodate standard bearing housings and provide easy initial alignment of shaft and equipment.

To facilitate positive location of the flange to the surface, the rear face is recessed (dimensions N and V). This allows for a spigot (tolerance f8) to be located into the flange.

Bearing inspection is simply a matter of removing the top half of the flange and housing. Bearing replacement also may be achieved in the same manner if required.

When integrating flange units into new applications, it should be noted that a maximum radial load equivalent to 0.26 C<sub>or</sub> is permissible. A maximum axial load of 0.25 C<sub>a</sub> also must be taken into account for applications with thrust loading. Units for vertically oriented shafts may also need special consideration given to sealing arrangements.

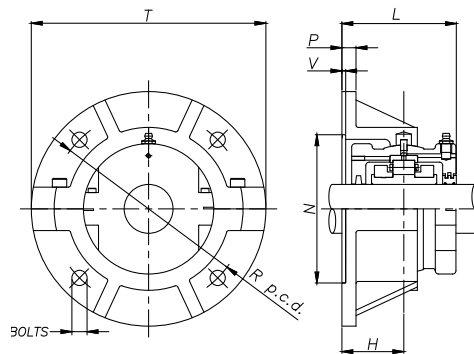

| Shaft (d)         |                                  | Flange Reference | T           | R           | P         | H          | N                | V         | L           |
|-------------------|----------------------------------|------------------|-------------|-------------|-----------|------------|------------------|-----------|-------------|
| mm                | in.                              |                  | mm<br>in.   | mm<br>in.   | mm<br>in. | mm<br>in.  | mm<br>in.        | mm<br>in. | mm<br>in.   |
| 125<br>130        | 4 15/16<br>5                     | F56              | 530<br>20.9 | 460<br>18.1 | 34<br>1.3 | 122<br>4.8 | 390.45<br>15.372 | 7<br>0.3  | 233<br>9.2  |
| 150<br>155        | 5 11/16<br>5 3/4<br>5 15/16<br>6 | F58              | 648<br>25.5 | 574<br>22.6 | 44<br>1.7 | 137<br>5.4 | 495.35<br>19.502 | 7<br>0.3  | 264<br>10.4 |
| 175<br>180        | 6 3/4<br>6 15/16<br>7            | F60              | 724<br>28.5 | 638<br>25.1 | 44<br>1.7 | 156<br>6.1 | 546.15<br>21.502 | 8<br>0.3  | 298<br>11.7 |
| 240<br>250<br>260 | 9 1/2<br>9 3/4<br>10             | F63              | 890<br>35.0 | 796<br>31.3 | 48<br>1.9 | 181<br>7.1 | 692.20<br>27.252 | 8<br>0.3  | 348<br>13.7 |

For bearings and housings see page 72.



## SAF/SN/SD BEARINGS

The new compact split plummer block bearing from Timken is the first split cylindrical roller bearing assembly to be interchangeable with standard SAF, SN and SD series plummer blocks, bringing the benefits of a split design to a much wider customer base.

The following topics are covered within this section:

|                                                                                             |    |
|---------------------------------------------------------------------------------------------|----|
| SAFQ Two-Bolt/SAFQ Four-Bolt Bearing and Housing<br>1 7/16 in. to 3 7/16 in.....            | 78 |
| SAFQ Two-Bolt/SAFQ Four-Bolt Support SAFQ1-2B - SAFQ05-2B... .                              | 79 |
| SAFQ Two-Bolt/SAFQ Four-Bolt Bearing and Housing<br>3 7/16 in. to 7 1/16 in.....            | 80 |
| SAFQ Two-Bolt/SAFQ Four-Bolt Support SAFQ06A - SAFQ34A. . .                                 | 81 |
| Light SNQ/SDQ Range Bearing and Housing<br>35 mm to 160 mm (1 3/8 in. to 6 in.) . . . . .   | 82 |
| Light SNQ/SDQ Range Support SNQ01 - SNQ10 . . . . .                                         | 83 |
| Light SNQ/SDQ Range Bearing and Housing<br>160 mm to 305 mm (6 3/8 in. to 12 in.) . . . . . | 84 |
| Light SNQ/SDQ Range Support SDQ11 - SDQ17. . . . .                                          | 85 |
| Light SN/SD Range Bearings and Housings<br>35 mm to 160 mm (1 3/8 in. to 6 in.) . . . . .   | 86 |
| Light SN/SD Range Support SN01 - SD10 . . . . .                                             | 87 |
| Light SN/SD Range Bearings and Housings<br>160 mm to 305 mm (6 3/8 in. to 12 in.) . . . . . | 88 |
| Light SN/SD Range Support SD11 - SD17 . . . . .                                             | 89 |
| Medium SN/SD Range Bearing and Housing<br>135 mm to 260 mm (5 3/8 in. to 10 in.) . . . . .  | 90 |
| Medium SN/SD Range Support SN30 - SD36A. . . . .                                            | 91 |
| Medium SN/SD Range Bearing and Housing<br>270 mm to 400 mm (10 1/2 in. to 16 in.) . . . . . | 92 |
| Medium SN/SD Range Support SD37 - SD42 . . . . .                                            | 93 |

# SAFQ TWO-BOLT / SAFQ FOUR-BOLT BEARING AND HOUSING

## 1 7/16 IN. TO 3 7/16 IN.

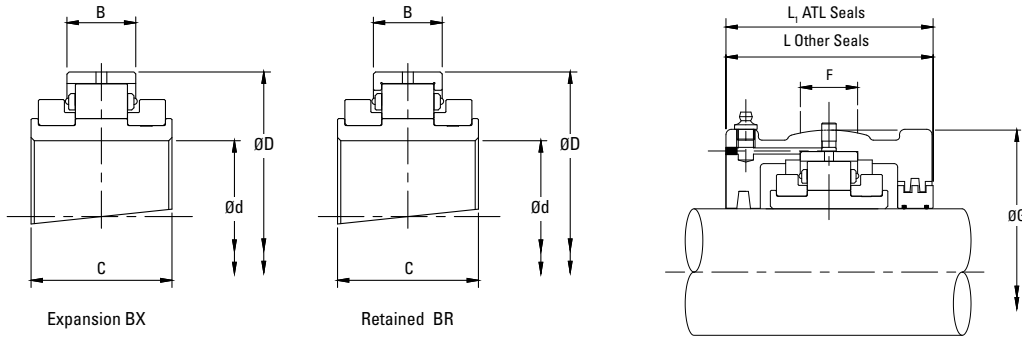

| Shaft (d) | Reference                                                 |                         |                            | Bearings Ratings      |                       |        |                        |                      |                      | Housing Reference |           |                        |                    |                     |                     |
|-----------|-----------------------------------------------------------|-------------------------|----------------------------|-----------------------|-----------------------|--------|------------------------|----------------------|----------------------|-------------------|-----------|------------------------|--------------------|---------------------|---------------------|
|           | Add <b>BR</b> for Retained<br>Add <b>BX</b> for Expansion | Additional Bearing(s)   |                            | Dynamic $C_r$         | Static $C_{or}$       | Max    | D                      | B                    | C                    | Retained          | Expansion | G                      | F                  | L                   | $L_1$               |
|           |                                                           | in.                     | mm                         | in.                   | kN lb.                | kN lb. | RPM                    | mm in.               | mm in.               | mm in.            |           | mm in.                 | mm in.             | mm in.              | mm in.              |
| 1 7/16    | LSE107                                                    | LSM30<br>LSM35<br>LSM40 | LSE103<br>LSE104           | <b>63.5</b><br>14296  | <b>65.4</b><br>14724  | 5400   | <b>84.14</b><br>3.313  | <b>23.8</b><br>0.937 | <b>55</b><br>2.165   | LS1HRTL           | LS1HXTL   | <b>100</b><br>3.937    | <b>25</b><br>0.984 | <b>84</b><br>3.307  | <b>91</b><br>3.582  |
| 1 11/16   | LSE111                                                    | LSM45                   | LSE112                     | <b>83.1</b><br>18694  | <b>87.3</b><br>19643  | 4630   | <b>98.42</b><br>3.875  | <b>25.4</b><br>1.000 | <b>60</b><br>2.362   | LS2HRTL           | LS2HXTL   | <b>117.48</b><br>4.625 | <b>25</b><br>0.984 | <b>96</b><br>3.780  | <b>98</b><br>3.858  |
| 1 15/16   | LSE115                                                    | LSM45<br>LSM50          | LSE111<br>LSE112<br>LSE200 | <b>83.1</b><br>18695  | <b>87.3</b><br>19644  | 4630   | <b>98.42</b><br>3.875  | <b>25.4</b><br>1.000 | <b>60</b><br>2.362   | LS2HRTL           | LS2HXTL   | <b>117.48</b><br>4.625 | <b>25</b><br>0.984 | <b>96</b><br>3.780  | <b>98</b><br>3.858  |
| 2 3/16    | LSE203                                                    | LSM55<br>LSM60<br>LSM65 | LSE204<br>LSE207<br>LSE208 | <b>102.7</b><br>23118 | <b>115</b><br>25848   | 3940   | <b>114.3</b><br>4.500  | <b>27</b><br>1.063   | <b>60</b><br>2.362   | LS3HRTL           | LS3HXTL   | <b>134.94</b><br>5.313 | <b>32</b><br>1.260 | <b>102</b><br>4.016 | <b>104</b><br>4.094 |
| 2 7/16    | LSE207                                                    | LSM55<br>LSM60<br>LSM65 | LSE203<br>LSE204<br>LSE208 | <b>102.7</b><br>23118 | <b>114.9</b><br>25848 | 3940   | <b>114.3</b><br>4.500  | <b>27</b><br>1.063   | <b>60</b><br>2.362   | LS3HRTL           | LS3HXTL   | <b>134.94</b><br>5.313 | <b>32</b><br>1.260 | <b>102</b><br>4.016 | <b>104</b><br>4.094 |
| 2 7/16    | LSE207                                                    | LSM55<br>LSM60<br>LSM65 | LSE203<br>LSE204<br>LSE208 | <b>102.7</b><br>23118 | <b>114.9</b><br>25848 | 3940   | <b>114.3</b><br>4.500  | <b>27</b><br>1.063   | <b>60</b><br>2.362   | LS3HRTL           | LS3HXTL   | <b>134.94</b><br>5.313 | <b>32</b><br>1.260 | <b>102</b><br>4.016 | <b>104</b><br>4.094 |
| 2 11/16   | LSE211                                                    | LSM70<br>LSM75          | LSE212<br>LSE215<br>LSE300 | <b>138</b><br>31041   | <b>160.8</b><br>36179 | 3310   | <b>133.35</b><br>5.250 | <b>31.8</b><br>1.252 | <b>65</b><br>2.559   | LS4HRTL           | LS4HXTL   | <b>157.16</b><br>6.187 | <b>38</b><br>1.496 | <b>112</b><br>4.409 | <b>114</b><br>4.488 |
| 2 11/16   | LSE211                                                    | LSM70<br>LSM75          | LSE212<br>LSE215<br>LSE300 | <b>138</b><br>31041   | <b>160.8</b><br>36179 | 3310   | <b>133.35</b><br>5.250 | <b>31.8</b><br>1.252 | <b>65</b><br>2.559   | LS4HRTL           | LS4HXTL   | <b>157.16</b><br>6.187 | <b>38</b><br>1.496 | <b>112</b><br>4.409 | <b>114</b><br>4.488 |
| 2 15/16   | LSE215                                                    | LSM70<br>LSM75          | LSE211<br>LSE212<br>LSE300 | <b>138</b><br>31041   | <b>160.8</b><br>36179 | 3310   | <b>133.35</b><br>5.250 | <b>31.8</b><br>1.252 | <b>65</b><br>2.559   | LS4HRTL           | LS4HXTL   | <b>157.16</b><br>6.187 | <b>38</b><br>1.496 | <b>112</b><br>4.409 | <b>114</b><br>4.488 |
| 2 15/16   | MSE215                                                    | MSM70                   | MSE211<br>MSE212<br>MSE300 | <b>258</b><br>58051   | <b>300.3</b><br>67566 | 3080   | <b>149.22</b><br>5.875 | <b>46.1</b><br>1.815 | <b>82.6</b><br>3.252 | MSSHRTL           | MSSHXTL   | <b>177.8</b><br>7.000  | <b>50</b><br>1.969 | <b>138</b><br>5.433 | <b>140</b><br>5.512 |
| 3 3/16    | LSE303                                                    | LSM80<br>LSM85          | LSE304                     | <b>187.3</b><br>42145 | <b>231.3</b><br>52033 | 2790   | <b>152.4</b><br>6.000  | <b>38.9</b><br>1.532 | <b>70.7</b><br>2.784 | LS5HRTL           | LS5HXTL   | <b>177.8</b><br>7.000  | <b>50</b><br>1.969 | <b>134</b><br>5.276 | <b>136</b><br>5.354 |
| 3 7/16    | LSE307                                                    | LSM80<br>LSM85          | LSE303<br>LSE304<br>LSE308 | <b>187.3</b><br>42145 | <b>231.3</b><br>52033 | 2790   | <b>152.4</b><br>6.000  | <b>38.9</b><br>1.532 | <b>70.7</b><br>2.784 | LS5HRTL           | LS5HXTL   | <b>177.8</b><br>7.000  | <b>50</b><br>1.969 | <b>134</b><br>5.276 | <b>136</b><br>5.354 |



## SAFQ TWO-BOLT / SAFQ FOUR-BOLT SUPPORT SAFQ1-2B - SAFQ05-2B

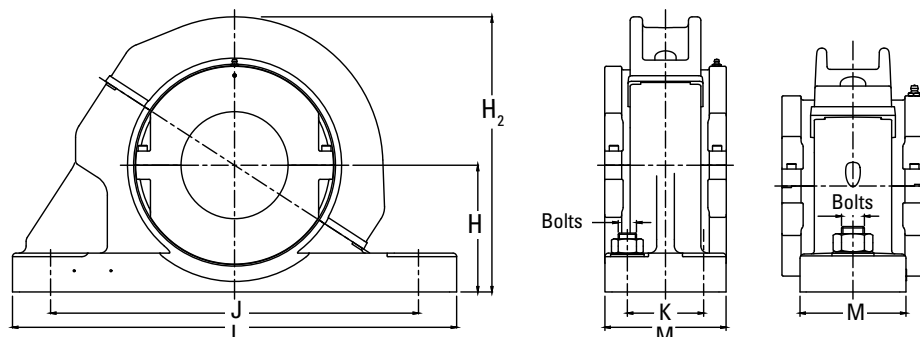

| Shaft<br>(d) | Support<br>Reference | SAF<br>Reference | Additional<br>Shafts |                          | H     | J      |        | K     | Bolts   | L        | M       | H <sub>2</sub> |
|--------------|----------------------|------------------|----------------------|--------------------------|-------|--------|--------|-------|---------|----------|---------|----------------|
|              |                      |                  | mm                   | in.                      |       | Min.   | Max.   |       |         |          |         |                |
| in.          |                      |                  | mm                   | in.                      | in.   | in.    | in.    | in.   |         | in.      | in.     | in.            |
| 1 1/16       | SAFQ01-2B            | SAF 509 2-BOLT   | 30<br>35<br>40       | 1 3/16<br>1 1/4          | 2 1/4 | 6 1/4  | 7      | –     | 2 x 1/2 | 8 1/4    | 2 3/16  | 5.2            |
| 1 11/16      | SAFQ02-2B            | SAF 510 2-BOLT   | 45                   | 1 3/4                    | 2 1/2 | 6 1/2  | 7      | –     | 2 x 1/2 | 8 1/4    | 2 3/8   | 5.9            |
| 1 15/16      | SAFQ02A-2B           | SAF 511 2-BOLT   | 45<br>50             | 1 11/16<br>1 3/4<br>2    | 2 3/4 | 7 3/8  | 8 1/4  | –     | 2 x 5/8 | 9 5/8    | 2 3/4   | 6.15           |
| 2 3/16       | SAFQ03-2B            | SAF 513 2-BOLT   | 55<br>60<br>65       | 2 1/4<br>2 7/16<br>2 1/2 | 3     | 8 1/4  | 9 1/2  | –     | 2 x 5/8 | 11       | 3 1/4   | 6.95           |
| 2 7/16       | SAFQ03A-2B           | SAF 515 2-BOLT   | 55<br>60<br>65       | 2 3/16<br>2 1/4<br>2 1/2 | 3 1/4 | 8 5/8  | 9 5/8  | –     | 2 x 5/8 | 11 1/8   | 3 1/8   | 7.2            |
| 2 7/16       | SAFQ03A-4B           | SAF 515 4-BOLT   | 55<br>60<br>65       | 2 3/16<br>2 1/4<br>2 1/2 | 3 1/4 | 8 5/8  | 9 5/8  | 1 7/8 | 4 x 1/2 | 11 1/8   | 3 1/8   | 7.2            |
| 2 11/16      | SAFQ04A-2B           | SAF 516 2-BOLT   | 70<br>75             | 2 3/4<br>2 15/16<br>3    | 3 1/2 | 9 3/4  | 11     | –     | 2 x 3/4 | 12 19/32 | 3 1/2   | 7.95           |
| 2 11/16      | SAFQ04A-4B           | SAF 516 4-BOLT   | 70<br>75             | 2 3/4<br>2 15/16<br>3    | 3 1/2 | 9 5/8  | 11     | 2 1/8 | 4 x 5/8 | 12 19/32 | 3 1/2   | 7.95           |
| 2 15/16      | SAFQ04-2B            | SAF 517 2-BOLT   | 70<br>75             | 2 11/16<br>2 3/4<br>3    | 3 3/4 | 9 7/8  | 11     | –     | 2 x 3/4 | 12 19/32 | 3 1/2   | 8.2            |
| 2 15/16      | SAFQ05A-4B           | SAF 517 4-BOLT   | 80<br>85             | 2 11/16<br>2 3/4         | 3 3/4 | 9 7/8  | 11     | 2 1/8 | 4 x 5/8 | 12 19/32 | 3 1/2   | 8.5            |
| 3 3/16       | SAFQ05B-2B           | SAF 518 2-BOLT   | 80<br>85             | 3 1/4                    | 4     | 10 1/4 | 11 3/4 | –     | 2 x 3/4 | 13 5/8   | 3 7/8   | 8.95           |
| 3 3/16       | SAFQ05-2B            | SAF 520 2-BOLT   | 80<br>85<br>90       | 3 3/16<br>3 1/4<br>3 1/2 | 4 1/2 | 11 5/8 | 13 1/8 | –     | 2 x 7/8 | 15 23/64 | 4 11/32 | 9.6            |

# SAFQ TWO-BOLT / SAFQ FOUR-BOLT BEARING AND HOUSING

## 3 7/16 IN. TO 7 15/16 IN.

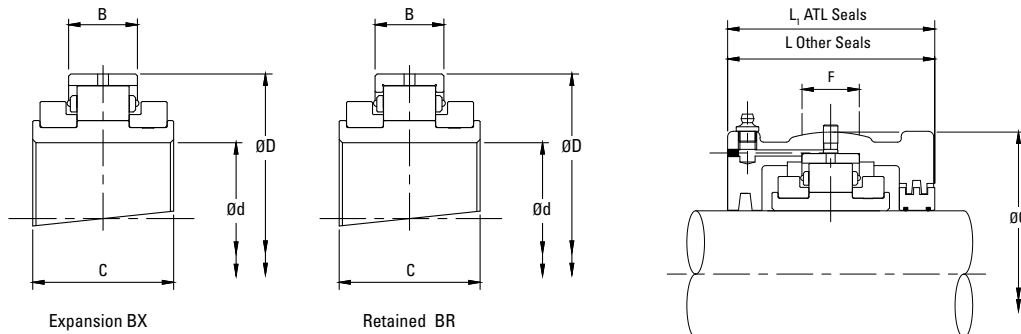

| Shaft (d) | Reference                                                 |                                                 |                                      | Bearings Ratings        |                         |        |                         |                      |                       | Housing Reference  |                    |                         |                     |                     |                      |
|-----------|-----------------------------------------------------------|-------------------------------------------------|--------------------------------------|-------------------------|-------------------------|--------|-------------------------|----------------------|-----------------------|--------------------|--------------------|-------------------------|---------------------|---------------------|----------------------|
|           | Add <b>BR</b> for Retained<br>Add <b>BX</b> for Expansion | Additional Bearing(s)                           |                                      | Dynamic $C_r$           | Static $C_{or}$         | Max    | D                       | B                    | C                     | Retained           | Expansion          | G                       | F                   | L                   | $L_1$                |
|           |                                                           | in.                                             | mm                                   | in.                     | kN lb.                  | kN lb. | RPM                     | mm in.               | mm in.                | mm in.             |                    |                         | mm in.              | mm in.              | mm in.               |
| 3 7/16    | MSE307                                                    | <b>MSM80</b><br><b>MSM85</b>                    | MSE303<br>MSE304<br>MSE308           | <b>297</b><br>66830     | <b>352.5</b><br>79315   | 2520   | <b>169.86</b><br>6.687  | <b>48.4</b><br>1.906 | <b>89.7</b><br>3.532  | MS6HRTL            | MS6HXTL            | <b>203.2</b><br>8.000   | <b>50</b><br>1.969  | <b>152</b><br>5.984 | <b>154</b><br>6.063  |
| 3 3/16    | MSE315                                                    | <b>MSM95</b><br><b>MSM100</b>                   | MSE311<br>MSE312<br>MSE400           | <b>387.7</b><br>87235   | <b>490.6</b><br>110375  | 2130   | <b>193.68</b><br>7.625  | <b>51.6</b><br>2.032 | <b>92.1</b><br>3.626  | MS7HRTL            | MS7HXTL            | <b>231.78</b><br>9.125  | <b>64</b><br>2.517  | <b>144</b><br>5.669 | <b>146</b><br>5.748  |
| 4 3/16    | LSE403                                                    | <b>LSM110</b><br><b>LSM115</b>                  | LSE404<br>LSE406<br>LSE407<br>LSE408 | <b>316</b><br>71105     | <b>426.9</b><br>96059   | 1970   | <b>203.2</b><br>8.000   | <b>46.9</b><br>1.847 | <b>84.9</b><br>3.343  | LS7HRTL            | LS7HXTL            | <b>231.78</b><br>9.125  | <b>64</b><br>2.517  | <b>140</b><br>5.512 | <b>142</b><br>5.591  |
| 4 7/16    | MSE407                                                    | <b>MSM110</b><br><b>MSM115</b>                  | MSE403<br>MSE404<br>MSE406<br>MSE408 | <b>453.9</b><br>102130  | <b>591.7</b><br>133135  | 1820   | <b>228.6</b><br>9.000   | <b>57.2</b><br>2.252 | <b>100</b><br>3.937   | MS8HRTL            | MS8HXTL            | <b>266.7</b><br>10.500  | <b>76</b><br>2.992  | <b>160</b><br>6.299 | <b>162</b><br>6.378  |
| 4 15/16   | MSE415                                                    | <b>MSM120</b><br><b>MSM125</b>                  | MSE411<br>MSE412                     | <b>524.8</b><br>118084  | <b>700.3</b><br>157566  | 1600   | <b>254</b><br>10.000    | <b>63.5</b><br>2.189 | <b>114.3</b><br>3.874 | MS10HR-<br>TLE0509 | MS10HX-<br>TLE0509 | <b>287.98</b><br>11.625 | <b>82</b><br>3.228  | <b>182</b><br>6.772 | <b>184</b><br>6.850  |
| 5 3/16    | LSE503                                                    | <b>LSM135</b><br><b>LSM140</b>                  | LSE504<br>LSE507<br>LSE508           | <b>422.5</b><br>95055   | <b>585.2</b><br>131675  | 1570   | <b>241.3</b><br>9.500   | <b>55.6</b><br>2.189 | <b>98.4</b><br>3.874  | LS9HRTL            | LS9HXTL            | <b>279.4</b><br>11.000  | <b>76</b><br>2.992  | <b>166</b><br>6.535 | <b>168</b><br>6.614  |
| 5 7/16    | MSE507                                                    | <b>MSM135</b><br><b>MSM140</b>                  | MSE503<br>MSE504<br>MSE508           | <b>600.4</b><br>135088  | <b>816.6</b><br>183729  | 1450   | <b>273.05</b><br>10.750 | <b>66.7</b><br>2.626 | <b>117.5</b><br>4.626 | MS30HRTL           | MS30HXTL           | <b>323.85</b><br>12.750 | <b>90</b><br>3.543  | <b>186</b><br>7.323 | <b>188</b><br>7.402  |
| 5 15/16   | MSE515                                                    | <b>MSM150</b>                                   | MSE511<br>MSE512<br>MSE514           | <b>730.2</b><br>164289  | <b>1033.8</b><br>232600 | 1320   | <b>292.1</b><br>11.500  | <b>68.3</b><br>2.689 | <b>123.8</b><br>4.874 | MS31HRTL           | MS31HXTL           | <b>336.55</b><br>13.250 | <b>95</b><br>3.740  | <b>202</b><br>7.953 | <b>204</b><br>8.031  |
| 6 7/16    | MSE607                                                    | <b>MSM160</b>                                   | MSE608                               | <b>824.1</b><br>185430  | <b>1143</b><br>257168   | 1200   | <b>317.5</b><br>12.500  | <b>83.3</b><br>3.280 | <b>140</b><br>5.512   | MS32HRTL           | MS32HXTL           | <b>368.3</b><br>14.500  | <b>95</b><br>3.740  | <b>206</b><br>8.110 | <b>232</b><br>9.134  |
| 6 15/16   | LSE615                                                    | <b>LSM170</b><br><b>LSM175</b><br><b>LSM180</b> | LSE611<br>LSE612<br>LSE700           | <b>524.4</b><br>117993  | <b>827.7</b><br>186233  | 1220   | <b>285.75</b><br>11.250 | <b>55.5</b><br>2.185 | <b>109</b><br>4.291   | LS12HRTL           | LS12HXTL           | <b>323.85</b><br>12.750 | <b>70</b><br>2.756  | <b>172</b><br>6.772 | <b>200</b><br>7.874  |
| 7 3/16    | LSE703                                                    | <b>LSM190</b><br><b>LSM200</b>                  | LSE704<br>LSE708<br>LSE715<br>LSE800 | <b>607</b><br>136576    | <b>989.7</b><br>222676  | 1070   | <b>311.15</b><br>12.250 | <b>60.3</b><br>2.374 | <b>109</b><br>4.291   | LS13HRTL           | LS13HXTL           | <b>258.78</b><br>10.188 | <b>86</b><br>3.386  | <b>172</b><br>6.772 | <b>200</b><br>7.874  |
| 7 15/16   | MSE715                                                    | <b>MSM190</b><br><b>MSM200</b>                  | MSE703<br>MSE704<br>MSE708<br>MSE800 | <b>1012.9</b><br>227893 | <b>1516.3</b><br>341160 | 960    | <b>368.3</b><br>14.500  | <b>90.5</b><br>3.563 | <b>156</b><br>6.142   | MS34HRTL           | MS34HXTL           | <b>425.5</b><br>16.752  | <b>105</b><br>4.134 | <b>235</b><br>9.252 | <b>258</b><br>10.157 |

continued on next page

# SAFQ TWO-BOLT / SAFQ FOUR-BOLT SUPPORT

## SAFQ06A - SAFQ34A

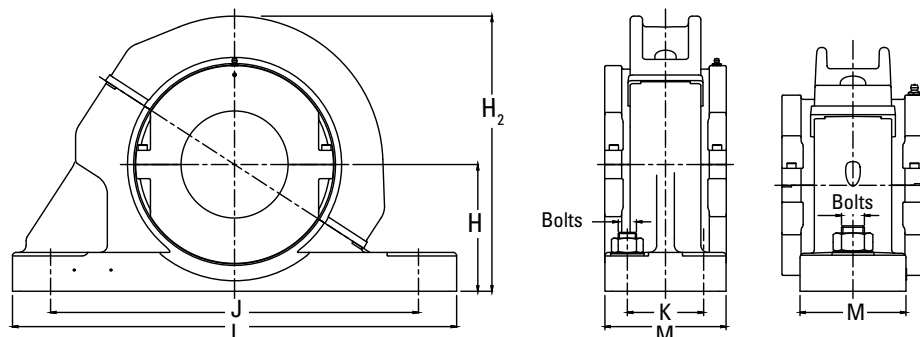

| Shaft<br>(d) | Support<br>Reference | SAF<br>Reference | Additional<br>Shafts                   |                                   | H       | J       |        | K     | Bolts     | L        | M       | H <sub>2</sub> |
|--------------|----------------------|------------------|----------------------------------------|-----------------------------------|---------|---------|--------|-------|-----------|----------|---------|----------------|
|              |                      |                  | mm                                     | in.                               |         | Min.    | Max.   |       |           |          |         |                |
| in.          |                      |                  | mm                                     | in.                               | in.     | in.     | in.    | in.   |           | in.      | in.     | in.            |
| 3 7/16       | SAFQ06A              | SAF 520 4-BOLT   | <b>80</b><br><b>85</b>                 | 3 3/16<br>3 1/4<br>3 1/2          | 4 1/2   | 11 5/8  | 13 1/8 | 2 3/8 | 4 x 3/4   | 15 23/64 | 4 11/32 | 9.95           |
| 3 15/16      | SAFQ07A              | SAF 522          | <b>95</b><br><b>100</b>                | 3 11/16<br>3 3/4<br>4             | 4 15/16 | 12 5/16 | 14 1/2 | 2 3/4 | 4 x 3/4   | 16 1/2   | 4 3/4   | 11             |
| 4 3/16       | SAFQ07B              | SAF 524          | <b>110</b><br><b>115</b>               | 4 1/4<br>4 3/8<br>4 7/16<br>4 1/2 | 5 1/4   | 13 3/4  | 14 1/2 | 2 3/4 | 4 x 3/4   | 16 1/2   | 4 3/4   | 11.3           |
| 4 7/16       | SAFQ08A              | SAF526           | <b>110</b><br><b>115</b>               | 4 3/16<br>4 1/4<br>4 3/8<br>4 1/2 | 6       | 14 1/2  | 16     | 3 1/4 | 4 x 7/8   | 18 3/8   | 5 1/8   | 13.1           |
| 4 15/16      | SAFQ10A              | SAF528           | <b>120</b><br><b>125</b>               | 4 11/16<br>4 3/4<br>5             | 6       | 15 5/8  | 17 3/8 | 3 3/8 | 4 x 1     | 19 45/64 | 5 7/8   | 13.3           |
| 5 3/16       | SAFQ09A              | SAF530           | <b>135</b><br><b>140</b>               | 5 7/16<br>5 1/4<br>5 1/2          | 6 3/16  | 16 3/4  | 18 1/2 | 3 3/4 | 4 x 1     | 21 1/4   | 6 1/4   | 14.2           |
| 5 7/16       | SAFQ30               | SAF532           | <b>135</b><br><b>140</b>               | 5 3/16<br>5 1/4<br>5 1/2          | 6 11/16 | 17 3/8  | 19 1/4 | 3 3/4 | 4 x 1     | 21 21/32 | 6 1/4   | 15.15          |
| 5 15/16      | SAFQ31               | SAF534           | <b>150</b>                             | 5 11/16<br>5 3/4<br>5 7/8<br>6    | 7 1/16  | 19 3/8  | 21 5/8 | 4 1/4 | 4 x 1     | 24 3/4   | 6 3/4   | 15.75          |
| 6 7/16       | SAFQ32               | SAF536           | <b>160</b>                             | 6 1/2                             | 7 1/2   | 20 7/8  | 23 3/8 | 4 5/8 | 4 x 1     | 26 3/4   | 7 1/8   | 17.6           |
| 6 15/16      | SAFQ12               | SAF538           | <b>170</b><br><b>175</b><br><b>180</b> | 6 11/16<br>6 3/4<br>7             | 7 7/8   | 21 5/8  | 24 3/8 | 4 1/2 | 4 x 1 1/4 | 28       | 7 1/2   | 16.75          |
| 7 3/16       | SAFQ13               | SAF540           | <b>190</b><br><b>200</b>               | 7 1/4<br>7 1/2<br>7 11/16<br>8    | 8 1/4   | 22 1/2  | 25     | 5     | 4 x 1 1/4 | 29 3/8   | 8       | 17.7           |
| 7 15/16      | SAFQ34A              | SAF544           | <b>190</b><br><b>200</b>               | 7 3/16<br>7 1/4<br>7 1/2<br>8     | 9 1/2   | 24 3/4  | 27 7/8 | 5 1/4 | 4 x 1 1/2 | 32 3/4   | 8 3/4   | 21.35          |

**PRODUCT DATA TABLES**

**SAF/SN/SD BEARINGS • LIGHT SNQ/SDQ RANGE BEARING AND HOUSING • 35 MM TO 160 MM (1 3/16 IN. TO 6 IN.)**

**LIGHT SNQ/SDQ RANGE BEARING AND HOUSING  
35 MM TO 160 MM (1 3/16 IN. TO 6 IN.)**

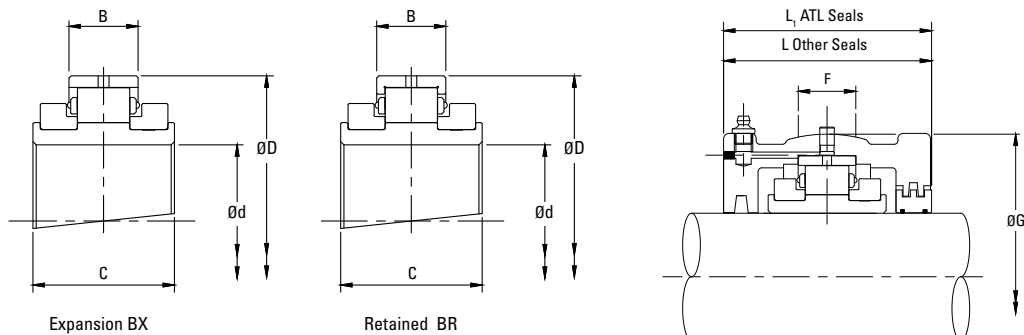

| Shaft (d)                                              |                                                           | Reference                                              |        | Bearings Ratings       |                        |                      |      |        |                   |       | Housing Reference |                             |                  |        |    |     |     |
|--------------------------------------------------------|-----------------------------------------------------------|--------------------------------------------------------|--------|------------------------|------------------------|----------------------|------|--------|-------------------|-------|-------------------|-----------------------------|------------------|--------|----|-----|-----|
|                                                        |                                                           |                                                        |        | Dynamic C <sub>r</sub> | Static C <sub>or</sub> | Axial C <sub>a</sub> | Max  | D      | B, B <sub>1</sub> | C     | ATL Seals         |                             | Other Seal Types |        | G  | F   | L   |
| Add BR for Retained Add BX for Expansion e.g. LSE103BR | Add HRTL for retained Add HXTL for Expansion e.g. LS1HRTL | Add HR for Retained Add HX for Expansion e.g. LSE103HR | mm in. |                        |                        |                      |      |        |                   |       | mm in.            | mm in.                      | mm in.           | mm in. |    |     |     |
| 35<br>40                                               | 1 3/16                                                    | LSM35<br>LSM40                                         | LSE103 | 65                     | 68                     | 3.20                 | 5400 | 84.14  | 23.80             | 55.00 | LS1               | LSM35<br>LSM40              | LSE103           | 100.00 | 25 | 84  | 91  |
|                                                        | 1 1/4                                                     |                                                        | LSE104 |                        |                        |                      |      |        |                   |       |                   |                             | 14613            |        |    |     |     |
| 45<br>50                                               | 1 1/16                                                    | LSM45<br>LSM50                                         | LSE111 | 83                     | 87                     | 3.60                 | 4630 | 98.42  | 25.40             | 60.00 | LS2               | LSM50                       | LSE111           | 117.48 | 25 | 96  | 98  |
|                                                        | 1 3/8                                                     |                                                        | LSE112 |                        |                        |                      |      |        |                   |       |                   |                             | 18659            |        |    |     |     |
| 55<br>60<br>65                                         | 2 3/16                                                    | LSM55<br>LSM60<br>LSM65                                | LSE203 | 103                    | 115                    | 5.40                 | 3940 | 114.30 | 27.00             | 60.00 | LS3               | LSM55<br>LSM60<br>LSM65     | LSE203           | 134.94 | 32 | 102 | 104 |
|                                                        | 2 1/4                                                     |                                                        | LSE204 |                        |                        |                      |      |        |                   |       |                   |                             | 23155            |        |    |     |     |
| 70<br>75                                               | 2 11/16                                                   | LSM70<br>LSM75                                         | LSE211 | 138                    | 161                    | 7.60                 | 3310 | 133.35 | 31.80             | 65.00 | LS4               | LSM70<br>LSM75              | LSE211           | 157.16 | 38 | 112 | 114 |
|                                                        | 2 3/4                                                     |                                                        | LSE212 |                        |                        |                      |      |        |                   |       |                   |                             | 31024            |        |    |     |     |
| 80<br>85<br>90                                         | 3 3/16                                                    | LSM80<br>LSM85<br>LSM90                                | LSE303 | 187                    | 231                    | 12.40                | 2790 | 152.40 | 38.90             | 75.00 | LS5               | LSM80<br>LSM85<br>LSM90     | LSE303           | 177.80 | 50 | 134 | 136 |
|                                                        | 3 1/4                                                     |                                                        | LSE304 |                        |                        |                      |      |        |                   |       |                   |                             | 42039            |        |    |     |     |
| 95<br>100<br>105                                       | 3 11/16                                                   | LSM95<br>LSM100<br>LSM105                              | LSE311 | 288                    | 366                    | 16.00                | 2340 | 174.62 | 45.30             | 85.00 | LS6               | LSM95<br>LSM100<br>LSM105   | LSE311           | 203.20 | 50 | 132 | 134 |
|                                                        | 3 3/4                                                     |                                                        | LSE312 |                        |                        |                      |      |        |                   |       |                   |                             | 64745            |        |    |     |     |
| 110<br>115                                             | 4 3/16                                                    | LSM110<br>LSM115                                       | LSE403 | 316                    | 427                    | 18.60                | 1970 | 203.20 | 46.90             | 90.00 | LS7               | LSM110<br>LSM115            | LSE403           | 231.78 | 64 | 140 | 142 |
|                                                        | 4 1/4                                                     |                                                        | LSE404 |                        |                        |                      |      |        |                   |       |                   |                             | 71040            |        |    |     |     |
| 120<br>125<br>130                                      | 4 11/16                                                   | LSM120<br>LSM125<br>LSM130                             | LSE411 | 363                    | 496                    | 22.20                | 1740 | 222.25 | 54.00             | 95.00 | LS8               | LSM120<br>LSM125<br>LSM130  | LSE411           | 266.70 | 76 | 154 | 156 |
|                                                        | 4 3/4                                                     |                                                        | LSE412 |                        |                        |                      |      |        |                   |       |                   |                             | 81606            |        |    |     |     |
| 135<br>140                                             | 5 3/16                                                    | LSM135<br>LSM140                                       | LSE503 | 422                    | 585                    | 25.80                | 1570 | 241.30 | 55.60             | 98.40 | LS9               | LSM135<br>LSM140            | LSE503           | 279.40 | 76 | 166 | 168 |
|                                                        | 5 1/4                                                     |                                                        | LSE504 |                        |                        |                      |      |        |                   |       |                   |                             | 94869            |        |    |     |     |
| 150<br>155<br>160                                      | 5 11/16                                                   | LSM150<br>LSM155<br>LSM160A                            | LSE511 | 459                    | 664                    | 29.40                | 1450 | 254.00 | 55.60             | 98.40 | LS10              | LSM150<br>LSM155<br>LSM160A | LSE511           | 295.28 | 82 | 172 | 174 |
|                                                        | 5 3/4                                                     |                                                        | LSE512 |                        |                        |                      |      |        |                   |       |                   |                             | 103187           |        |    |     |     |

# LIGHT SNQ/SDQ RANGE SUPPORT

## SNQ01 - SNQ10

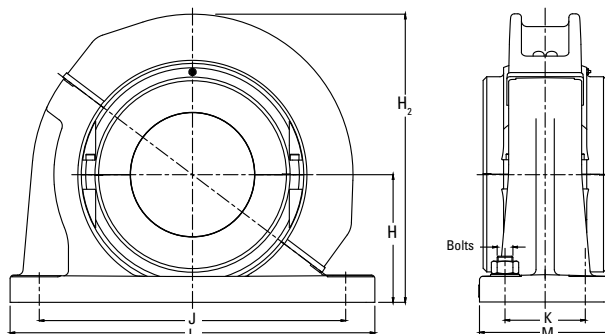

| Shaft (d)         |                                    | Spherical Roller Bearing Reference | SN/SD Reference            | H                 | H <sub>2</sub>    | J x K             | L x M                               | Bolts                         |
|-------------------|------------------------------------|------------------------------------|----------------------------|-------------------|-------------------|-------------------|-------------------------------------|-------------------------------|
| mm                | in.                                |                                    |                            |                   |                   |                   |                                     |                               |
| 35<br>40          | 1 3/16<br>1 1/4<br>1 7/16<br>1 1/2 | SNQ01                              | SN 508<br>SN 509           | 60                | 135               | 170               | 205 x 60                            | 2 x M12                       |
| 45<br>50          | 1 11/16<br>1 3/4<br>1 15/16<br>2   | SNQ02                              | SN 511                     | 70                | 155               | 210               | 255 x 70                            | 2 x M16                       |
| 55<br>60<br>65    | 2 3/16<br>2 1/4<br>2 7/16<br>2 1/2 | SNQ03                              | SN 513<br>SN 515           | 80                | 180               | 234               | 275 x 70                            | 2 x M16                       |
| 70<br>75          | 2 11/16<br>2 3/4<br>2 15/16<br>3   | SNQ04                              | SN 516<br>SN 517           | 95                | 208               | 260               | 315 x 90                            | 2 x M20                       |
| 80<br>85<br>90    | 3 3/16<br>3 1/4<br>3 7/16<br>3 1/2 | SNQ05<br>SNQ05A<br>SNQ05B          | SN 518<br>SN 519<br>SN 520 | 100<br>112<br>112 | 230<br>242<br>242 | 290<br>290<br>320 | 345 x 100<br>345 x 100<br>380 x 110 | 2 x M20<br>2 x M20<br>2 x M24 |
| 95<br>100<br>105  | 3 11/16<br>3 3/4<br>3 15/16<br>4   | SNQ06                              | SN 522                     | 125               | 265               | 350               | 410 x 120                           | 2 x M24                       |
| 110<br>115        | 4 3/16<br>4 1/4<br>4 7/16<br>4 1/2 | SNQ07<br>SNQ07A                    | SN 524<br>SN 526           | 140<br>150        | 300<br>310        | 350<br>380        | 410 x 120<br>445 x 130              | 2 x M24<br>2 x M24            |
| 120<br>125<br>130 | 4 11/16<br>4 3/4<br>4 15/16<br>5   | SNQ08                              | SN 528                     | 150               | 354               | 420               | 500 x 150                           | 2 x M30                       |
| 135<br>140        | 5 3/16<br>5 1/4<br>5 7/16<br>5 1/2 | SNQ09<br>SNQ09A                    | SN 530<br>SN 532           | 160<br>170        | 369<br>379        | 450<br>470        | 530 x 160<br>550 x 160              | 2 x M30<br>2 x M30            |
| 150<br>155<br>160 | 5 11/16<br>5 3/4<br>5 15/16<br>6   | SDQ10                              | SD 3134                    | 170               | 379               | 430 x 100         | 510 x 180                           | 4 x M24                       |

# PRODUCT DATA TABLES

SAF/SN/SD BEARINGS • LIGHT SNQ/SDQ RANGE BEARING AND HOUSING • 160 MM TO 305 MM (6 7/16 IN. TO 12 IN.)

## LIGHT SNQ/SDQ RANGE BEARING AND HOUSING 160 MM TO 305 MM (6 7/16 IN. TO 12 IN.)

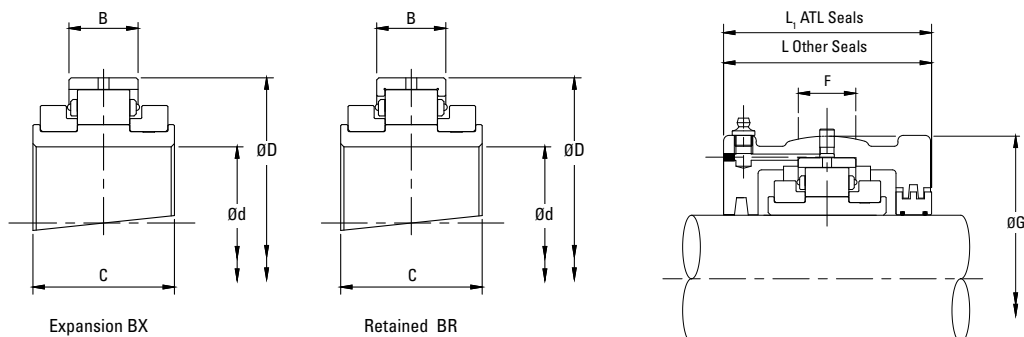

| Shaft (d)           |                      | Reference                   |                     | Bearings Ratings       |                        |                      |      |        |                   |        | Housing Reference |                             |                                      |               |     |     |     |
|---------------------|----------------------|-----------------------------|---------------------|------------------------|------------------------|----------------------|------|--------|-------------------|--------|-------------------|-----------------------------|--------------------------------------|---------------|-----|-----|-----|
|                     |                      |                             |                     | Dynamic C <sub>r</sub> | Static C <sub>or</sub> | Axial C <sub>a</sub> | Max  | D      | B, B <sub>1</sub> | C      | ATL Seals         |                             | Other Seal Types                     |               | G   | F   | L   |
| Add BR for Retained | Add BX for Expansion | Add HRTL for Retained       | Add HX for Retained |                        |                        |                      |      |        |                   |        | e.g. LSE103BR     | e.g. LSTHRTL                | e.g. LSE103HR                        | e.g. LSE103HR |     |     |     |
| mm                  | in.                  |                             |                     |                        |                        |                      |      |        |                   |        |                   |                             |                                      |               |     |     |     |
| 160                 | 6 7/16               | LSM160                      | LSE607              | 583                    | 792                    | 33.00                | 1320 | 273.05 | 60.30             | 109.00 | LS11              | LSM160<br>LSM170A           | LSE607<br>LSE608                     | 311.15        | 76  | 172 | 192 |
| 170                 | 6 1/2                | LSM170A                     | LSE608              | 131064                 | 178049                 | 7419                 |      | 10.750 | 2.374             | 4.291  |                   |                             |                                      | 12.250        | 3.0 | 6.8 | 7.6 |
| 170                 | 6 11/16              | LSM170                      | LSE611              | 524                    | 828                    | 36.40                | 1220 | 285.75 | 55.50             | 109.00 | LS12              | LSM170<br>LSM175<br>LSM180  | LSE611<br>LSE612<br>LSE615<br>LSE700 | 323.85        | 70  | 172 | 200 |
| 175                 | 6 3/4                | LSM175                      | LSE612              | 117800                 | 186142                 | 8183                 |      | 11.250 | 2.185             | 4.291  |                   |                             |                                      | 12.750        | 2.8 | 6.8 | 7.9 |
| 180                 | 6 15/16              | LSM180                      | LSE615              |                        |                        |                      |      |        |                   |        |                   |                             |                                      |               |     |     |     |
| 190                 | 7 1/16               | LSM190<br>LSM200            | LSE703              | 614                    | 990                    | 41.00                | 1070 | 311.15 | 60.30             | 106.00 | LS13              | LSM190<br>LSM200            | LSE703                               | 358.78        | 86  | 172 | 200 |
| 200                 | 7 1/4                |                             | LSE704              |                        |                        |                      |      |        |                   |        |                   |                             | LSE704                               |               |     |     |     |
| 220                 | 8 7/16               | LSM220<br>LSM230            | LSE807              | 708                    | 1168                   | 49.00                | 930  | 342.90 | 63.50             | 115.00 | LS14              | LSM220<br>LSM230            | LSE807                               | 387.35        | 82  | 178 | 216 |
| 230                 | 8 1/2                |                             | LSE808              |                        |                        |                      |      |        |                   |        |                   |                             | LSE808                               |               |     |     |     |
| 240                 | 8 7/8                |                             |                     |                        |                        |                      |      |        |                   |        |                   |                             |                                      |               |     |     |     |
| 250                 | 9 1/16               | LSM240<br>LSM250<br>LSM260A | LSE908              | 744                    | 1289                   | 57.80                | 820  | 374.65 | 66.70             | 122.00 | LS15              | LSM240<br>LSM250<br>LSM260A | LSE908                               | 419.10        | 90  | 188 | 222 |
| 260                 | 9 3/8                |                             | LSE912              |                        |                        |                      |      |        |                   |        |                   |                             | LSE912                               |               |     |     |     |
| 260                 | 9 7/8                |                             |                     |                        |                        |                      |      |        |                   |        |                   |                             |                                      |               |     |     |     |
| 270                 | 10 1/16              | LSM260<br>LSM270<br>LSM280  | LSE1007             | 848                    | 1502                   | 66.80                | 730  | 406.40 | 69.00             | 128.00 | LS16              | LSM260<br>LSM270<br>LSM280  | LSE1007                              | 454.00        | 95  | 204 | 232 |
| 280                 | 10 1/2               |                             | LSE1008             |                        |                        |                      |      |        |                   |        |                   |                             | LSE1008                              |               |     |     |     |
| 300                 | 10 3/4               |                             |                     |                        |                        |                      |      |        |                   |        |                   |                             |                                      |               |     |     |     |
| 305                 | 11 1/2               | LSM300                      | LSE1108             | 929                    | 1665                   | 78.20                | 650  | 438.15 | 74.60             | 143.00 | LS17              | LSM300<br>LSM305            | LSE1108<br>LSE1200                   | 489.00        | 98  | 216 | 248 |
|                     | 12                   | LSM305                      | LSE1200             | 208848                 | 374307                 | 17580                |      | 17.250 | 2.937             | 5.630  |                   |                             |                                      | 19.252        | 3.9 | 8.5 | 9.8 |

# LIGHT SNQ/SDQ RANGE SUPPORT

## SDQ11 - SDQ17

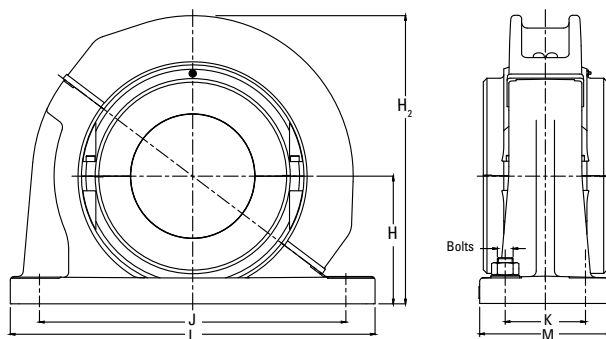

| Shaft (d)         |                                          | Spherical Roller Bearing Reference | SN/SD Reference    | H          | H <sub>2</sub> | J x K                  | L x M                  | Bolts              |
|-------------------|------------------------------------------|------------------------------------|--------------------|------------|----------------|------------------------|------------------------|--------------------|
| mm                | in.                                      |                                    |                    |            |                |                        |                        |                    |
| 160<br>170        | 6 7/16<br>6 1/2                          | SDQ11                              | SD 3136            | 180        | 396            | 450 x 110              | 530 x 190              | 4 x M24            |
| 170<br>175<br>180 | 6 11/16<br>6 3/4<br>6 15/16<br>7         | SDQ12<br>SDQ12A                    | SD 3138<br>SD 3140 | 190<br>210 | 417<br>437     | 480 x 120<br>510 x 130 | 560 x 210<br>610 x 230 | 4 x M24<br>4 x M30 |
| 190<br>200        | 7 3/16<br>7 1/4<br>7 1/2<br>7 15/16<br>8 | SDQ13                              | SD 3144            | 220        | 457            | 540 x 140              | 640 x 240              | 4 x M30            |
| 220<br>230        | 8 7/16<br>8 1/2<br>8 7/8<br>9            | SDQ14                              | SD 3148            | 240        | 510            | 600 x 150              | 700 x 260              | 4 x M30            |
| 240<br>250<br>260 | 9 1/2<br>9 3/4<br>10                     | SDQ15                              | SD 3152            | 260        | 545            | 650 x 160              | 770 x 280              | 4 x M36            |
| 260<br>270<br>280 | 10 7/16<br>10 1/2<br>10 3/4<br>11        | SDQ16<br>SDQ16A                    | SD 3156<br>SD 3160 | 280<br>300 | 589<br>609     | 670 x 160<br>710 x 190 | 790 x 280<br>830 x 310 | 4 x M36<br>4 x M36 |
| 300<br>305        | 11 1/2<br>12                             | SDQ17                              | SD3164             | 320        | 662            | 750 x 200              | 880 x 330              | 4 x M36            |

# LIGHT SN/SD RANGE BEARINGS AND HOUSINGS

## 35 MM TO 160 MM (1 3/16 IN. TO 6 IN.)

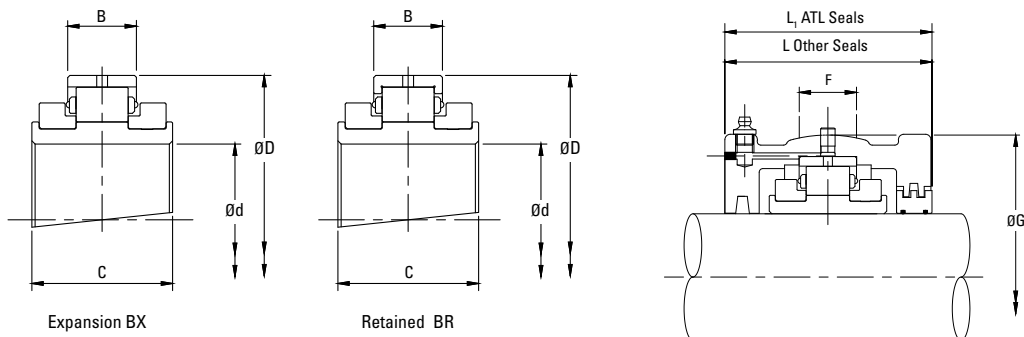

| Shaft (d) |         | Reference                                                    |        | Bearings Ratings |            |          |      |        |        | Housing Reference |                                                                           |                                                                               |        |        |        |        |     |
|-----------|---------|--------------------------------------------------------------|--------|------------------|------------|----------|------|--------|--------|-------------------|---------------------------------------------------------------------------|-------------------------------------------------------------------------------|--------|--------|--------|--------|-----|
|           |         | Add BR for Retained<br>Add BX for Expansion<br>e.g. LSE103BR |        | Dynamic Cr       | Static Cor | Axial Ca | Max  | D      | B      | C                 | ATL Seals<br>Add HRTL for Retained Add HXTL for Expansion<br>e.g. LS1HRTL | Other Seal Types<br>Add HR for Retained Add HX for Expansion<br>e.g. LSE103HR | G      | F      | L      | L1     |     |
| mm        | in.     |                                                              |        | kN lb.           | kN lb.     | kN lb.   | RPM  | mm in. | mm in. | mm in.            |                                                                           |                                                                               | mm in. | mm in. | mm in. | mm in. |     |
| 35        | 1 3/16  | LSM35                                                        | LSE103 | 65               | 68         | 3.20     | 5400 | 84.14  | 23.80  | 55.00             | LS1                                                                       | LSM35                                                                         | LSE103 | 100.00 | 25     | 84     | 91  |
|           | 1 1/4   |                                                              | LSE104 |                  |            |          |      |        |        |                   |                                                                           |                                                                               | LSE104 |        |        |        |     |
| 40        | 1 7/16  | LSM40                                                        | LSE107 | 14613            | 15287      | 719.38   | 5400 | 3.313  | 0.937  | 2.165             | LS1                                                                       | LSM40                                                                         | LSE107 | 3.937  | 1.0    | 3.3    | 3.6 |
|           | 1 1/2   |                                                              | LSE108 |                  |            |          |      |        |        |                   |                                                                           |                                                                               | LSE108 |        |        |        |     |
| 45        | 1 11/16 | LSM45                                                        | LSE111 | 83               | 87         | 3.60     | 4630 | 98.42  | 25.40  | 60.00             | LS2                                                                       | LSM50                                                                         | LSE111 | 117.48 | 25     | 96     | 98  |
|           | 1 3/4   |                                                              | LSE112 |                  |            |          |      |        |        |                   |                                                                           |                                                                               | LSE112 |        |        |        |     |
| 50        | 1 15/16 | LSM50                                                        | LSE115 | 18659            | 19558      | 809.30   | 4630 | 3.875  | 1.000  | 2.362             | LS2                                                                       | LSM50                                                                         | LSE115 | 4.625  | 1.0    | 3.8    | 3.9 |
|           | 2       |                                                              | LSE200 |                  |            |          |      |        |        |                   |                                                                           |                                                                               | LSE200 |        |        |        |     |
| 55        | 2 3/16  | LSM55                                                        | LSE203 | 103              | 115        | 5.40     | 3940 | 114.30 | 27.00  | 60.00             | LS3                                                                       | LSM55                                                                         | LSE203 | 134.94 | 32     | 102    | 104 |
|           | 2 1/4   |                                                              | LSE204 |                  |            |          |      |        |        |                   |                                                                           |                                                                               | LSE204 |        |        |        |     |
| 60        | 2 7/16  | LSM60                                                        | LSE207 | 23155            | 25853      | 1213.95  | 3940 | 4.500  | 1.063  | 2.362             | LS3                                                                       | LSM60                                                                         | LSE207 | 5.313  | 1.3    | 4.0    | 4.1 |
|           | 2 1/2   |                                                              | LSE208 |                  |            |          |      |        |        |                   |                                                                           |                                                                               | LSE208 |        |        |        |     |
| 65        | 2 1/2   | LSM65                                                        | LSE208 | 23155            | 25853      | 1213.95  | 3940 | 4.500  | 1.063  | 2.362             | LS3                                                                       | LSM65                                                                         | LSE208 | 5.313  | 1.3    | 4.0    | 4.1 |
|           | 2 1/2   |                                                              | LSE208 |                  |            |          |      |        |        |                   |                                                                           |                                                                               | LSE208 |        |        |        |     |
| 70        | 2 11/16 | LSM70                                                        | LSE211 | 138              | 161        | 7.60     | 3310 | 133.35 | 31.80  | 65.00             | LS4                                                                       | LSM70                                                                         | LSE211 | 157.16 | 38     | 112    | 114 |
|           | 2 3/4   |                                                              | LSE212 |                  |            |          |      |        |        |                   |                                                                           |                                                                               | LSE212 |        |        |        |     |
| 75        | 2 15/16 | LSM75                                                        | LSE215 | 31024            | 36194      | 1708.53  | 3310 | 5.250  | 1.252  | 2.559             | LS4                                                                       | LSM75                                                                         | LSE215 | 6.187  | 1.5    | 4.4    | 4.5 |
|           | 3       |                                                              | LSE300 |                  |            |          |      |        |        |                   |                                                                           |                                                                               | LSE300 |        |        |        |     |
| 80        | 3 3/16  | LSM80                                                        | LSE303 | 187              | 231        | 12.40    | 2790 | 152.40 | 38.90  | 75.00             | LS5                                                                       | LSM80                                                                         | LSE303 | 177.80 | 50     | 134    | 136 |
|           | 3 1/4   |                                                              | LSE304 |                  |            |          |      |        |        |                   |                                                                           |                                                                               | LSE304 |        |        |        |     |
| 85        | 3 7/16  | LSM85                                                        | LSE307 | 42039            | 51931      | 2787.59  | 2790 | 6.000  | 1.531  | 2.953             | LS5                                                                       | LSM85                                                                         | LSE307 | 7.000  | 2.0    | 5.3    | 5.4 |
|           | 3 1/2   |                                                              | LSE308 |                  |            |          |      |        |        |                   |                                                                           |                                                                               | LSE308 |        |        |        |     |
| 90        | 3 1/2   | LSM90                                                        | LSE308 | 42039            | 51931      | 2787.59  | 2790 | 6.000  | 1.531  | 2.953             | LS5                                                                       | LSM90                                                                         | LSE308 | 7.000  | 2.0    | 5.3    | 5.4 |
|           | 3 1/2   |                                                              | LSE308 |                  |            |          |      |        |        |                   |                                                                           |                                                                               | LSE308 |        |        |        |     |
| 95        | 3 11/16 | LSM95                                                        | LSE311 | 288              | 366        | 16.00    | 2340 | 174.62 | 45.30  | 85.00             | LS6                                                                       | LSM95                                                                         | LSE311 | 203.20 | 50     | 132    | 134 |
|           | 3 3/4   |                                                              | LSE312 |                  |            |          |      |        |        |                   |                                                                           |                                                                               | LSE312 |        |        |        |     |
| 100       | 3 3/4   | LSM100                                                       | LSE312 | 64745            | 82280      | 3596.90  | 2340 | 6.875  | 1.783  | 3.346             | LS6                                                                       | LSM100                                                                        | LSE312 | 8.000  | 2.0    | 5.2    | 5.3 |
|           | 3 15/16 |                                                              | LSE315 |                  |            |          |      |        |        |                   |                                                                           |                                                                               | LSE315 |        |        |        |     |
| 105       | 4       | LSM105                                                       | LSE400 | 64745            | 82280      | 3596.90  | 2340 | 6.875  | 1.783  | 3.346             | LS6                                                                       | LSM105                                                                        | LSE400 | 8.000  | 2.0    | 5.2    | 5.3 |
|           | 4       |                                                              | LSE400 |                  |            |          |      |        |        |                   |                                                                           |                                                                               | LSE400 |        |        |        |     |
| 110       | 4 3/16  | LSM110                                                       | LSE403 | 316              | 427        | 18.60    | 1970 | 203.20 | 46.90  | 90.00             | LS7                                                                       | LSM110                                                                        | LSE403 | 231.78 | 64     | 140    | 142 |
|           | 4 1/4   |                                                              | LSE404 |                  |            |          |      |        |        |                   |                                                                           |                                                                               | LSE404 |        |        |        |     |
| 115       | 4 7/16  | LSM115                                                       | LSE407 | 71040            | 95993      | 4181.39  | 1970 | 8.000  | 1.846  | 3.543             | LS7                                                                       | LSM115                                                                        | LSE407 | 9.125  | 2.5    | 5.5    | 5.6 |
|           | 4 1/2   |                                                              | LSE408 |                  |            |          |      |        |        |                   |                                                                           |                                                                               | LSE408 |        |        |        |     |
| 120       | 4 11/16 | LSM120                                                       | LSE411 | 363              | 496        | 22.20    | 1740 | 222.25 | 54.00  | 95.00             | LS8                                                                       | LSM120                                                                        | LSE411 | 266.70 | 76     | 154    | 156 |
|           | 4 3/4   |                                                              | LSE412 |                  |            |          |      |        |        |                   |                                                                           |                                                                               | LSE412 |        |        |        |     |
| 125       | 4 3/4   | LSM125                                                       | LSE412 | 81606            | 111505     | 4990.69  | 1740 | 8.750  | 2.126  | 3.740             | LS8                                                                       | LSM125                                                                        | LSE412 | 10.500 | 3.0    | 6.1    | 6.1 |
|           | 4 15/16 |                                                              | LSE415 |                  |            |          |      |        |        |                   |                                                                           |                                                                               | LSE415 |        |        |        |     |
| 130       | 5       | LSM130                                                       | LSE500 | 81606            | 111505     | 4990.69  | 1740 | 8.750  | 2.126  | 3.740             | LS8                                                                       | LSM130                                                                        | LSE500 | 10.500 | 3.0    | 6.1    | 6.1 |
|           | 5       |                                                              | LSE500 |                  |            |          |      |        |        |                   |                                                                           |                                                                               | LSE500 |        |        |        |     |
| 135       | 5 3/16  | LSM135                                                       | LSE503 | 422              | 585        | 25.80    | 1570 | 241.30 | 55.60  | 98.40             | LS9                                                                       | LSM135                                                                        | LSE503 | 279.40 | 76     | 166    | 168 |
|           | 5 1/4   |                                                              | LSE504 |                  |            |          |      |        |        |                   |                                                                           |                                                                               | LSE504 |        |        |        |     |
| 140       | 5 7/16  | LSM140                                                       | LSE507 | 94869            | 131513     | 5799.99  | 1570 | 9.500  | 2.189  | 3.874             | LS9                                                                       | LSM140                                                                        | LSE507 | 11.000 | 3.0    | 6.5    | 6.6 |
|           | 5 1/2   |                                                              | LSE508 |                  |            |          |      |        |        |                   |                                                                           |                                                                               | LSE508 |        |        |        |     |
| 150       | 5 11/16 | LSM150                                                       | LSE511 | 103187           | 149273     | 6609.30  | 1450 | 254.00 | 55.60  | 98.40             | LS10                                                                      | LSM150                                                                        | LSE511 | 295.28 | 82     | 172    | 174 |
|           | 5 3/4   |                                                              | LSE512 |                  |            |          |      |        |        |                   |                                                                           |                                                                               | LSE512 |        |        |        |     |
| 155       | 5 3/4   | LSM155                                                       | LSE512 | 103187           | 149273     | 6609.30  | 1450 | 254.00 | 55.60  | 98.40             | LS10                                                                      | LSM155                                                                        | LSE512 | 11.625 | 3.2    | 6.8    | 6.9 |
|           | 5 15/16 |                                                              | LSE515 |                  |            |          |      |        |        |                   |                                                                           |                                                                               | LSE515 |        |        |        |     |
| 160       | 6       | LSM160A                                                      | LSE600 | 103187           | 149273     | 6609.30  | 1450 | 10.000 | 2.189  | 3.874             | LS10                                                                      | LSM160A                                                                       | LSE600 | 11.625 | 3.2    | 6.8    | 6.9 |



# LIGHT SN/SD RANGE SUPPORT

## SN01 - SD10

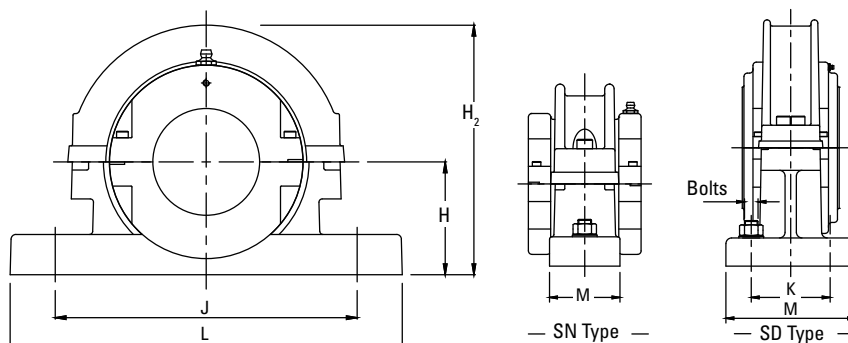

| Shaft (d)                              |                                    | Spherical Roller Bearing Reference | SN/SD Reference            | H          | H <sub>2</sub>   | J x K            | L x M            | Bolts   |
|----------------------------------------|------------------------------------|------------------------------------|----------------------------|------------|------------------|------------------|------------------|---------|
| mm                                     | in.                                |                                    |                            |            |                  |                  |                  |         |
| <b>35</b><br><b>40</b>                 | 1 3/16<br>1 1/4<br>1 7/16<br>1 1/2 | SN01                               | SN 508<br>SN 509           | <b>60</b>  | <b>135</b>       | <b>170</b>       | <b>205 x 60</b>  | 2 x M12 |
|                                        |                                    |                                    |                            |            |                  |                  |                  |         |
| <b>45</b><br><b>50</b>                 | 1 11/16<br>1 3/4<br>1 13/16<br>2   | SN02                               | SN 511                     | <b>70</b>  | <b>155</b>       | <b>210</b>       | <b>255 x 70</b>  | 2 x M16 |
|                                        |                                    |                                    |                            |            |                  |                  |                  |         |
| <b>55</b><br><b>60</b><br><b>65</b>    | 2 3/16<br>2 1/4<br>2 7/16<br>2 1/2 | SN03                               | SN 513<br>SN 515           | <b>80</b>  | <b>180</b>       | <b>234</b>       | <b>275 x 70</b>  | 2 x M16 |
|                                        |                                    |                                    |                            |            |                  |                  |                  |         |
| <b>70</b><br><b>75</b>                 | 2 11/16<br>2 3/4<br>2 15/16<br>3   | SN04                               | SN 516<br>SN 517           | <b>95</b>  | <b>208</b>       | <b>260</b>       | <b>315 x 90</b>  | 2 x M20 |
|                                        |                                    |                                    |                            |            |                  |                  |                  |         |
| <b>80</b><br><b>85</b><br><b>90</b>    | 3 3/16<br>3 1/4<br>3 7/16<br>3 1/2 | SN05<br>SN05A<br>SN05B             | SN 518<br>SN 519<br>SN 520 | <b>100</b> | <b>230</b>       | <b>290</b>       | <b>345 x 100</b> | 2 x M20 |
|                                        |                                    |                                    |                            | <b>112</b> | <b>242</b>       | <b>290</b>       | <b>345 x 100</b> | 2 x M20 |
|                                        |                                    | <b>112</b>                         | <b>242</b>                 | <b>320</b> | <b>380 x 110</b> | 2 x M24          |                  |         |
| <b>95</b><br><b>100</b><br><b>105</b>  | 3 11/16<br>3 3/4<br>3 15/16<br>4   | SN06                               | SN 522                     | <b>125</b> | <b>265</b>       | <b>350</b>       | <b>410 x 120</b> | 2 x M24 |
|                                        |                                    |                                    |                            |            |                  |                  |                  |         |
| <b>110</b><br><b>115</b>               | 4 3/16<br>4 1/4<br>4 7/16<br>4 1/2 | SN07<br>SN07A                      | SN 524<br>SN 526           | <b>140</b> | <b>300</b>       | <b>350</b>       | <b>410 x 120</b> | 2 x M24 |
|                                        |                                    |                                    |                            | <b>150</b> | <b>310</b>       | <b>380</b>       | <b>445 x 130</b> | 2 x M24 |
| <b>120</b><br><b>125</b><br><b>130</b> | 4 11/16<br>4 3/4<br>4 15/16<br>5   | SN08                               | SN 528                     | <b>150</b> | <b>354</b>       | <b>420</b>       | <b>500 x 150</b> | 2 x M30 |
|                                        |                                    |                                    |                            |            |                  |                  |                  |         |
| <b>135</b><br><b>140</b>               | 5 3/16<br>5 1/4<br>5 7/16<br>5 1/2 | SN09<br>SN09A                      | SN 530<br>SN 532           | <b>160</b> | <b>369</b>       | <b>450</b>       | <b>530 x 160</b> | 2 x M30 |
|                                        |                                    |                                    |                            | <b>170</b> | <b>379</b>       | <b>470</b>       | <b>550 x 160</b> | 2 x M30 |
| <b>150</b><br><b>155</b><br><b>160</b> | 5 11/16<br>5 3/4<br>5 15/16<br>6   | SD10                               | SD 3134                    | <b>170</b> | <b>379</b>       | <b>430 x 100</b> | <b>510 x 180</b> | 4 x M24 |
|                                        |                                    |                                    |                            |            |                  |                  |                  |         |

# LIGHT SN/SD RANGE BEARINGS AND HOUSINGS

## 160 MM TO 305 MM (6 7/16 IN. TO 12 IN.)

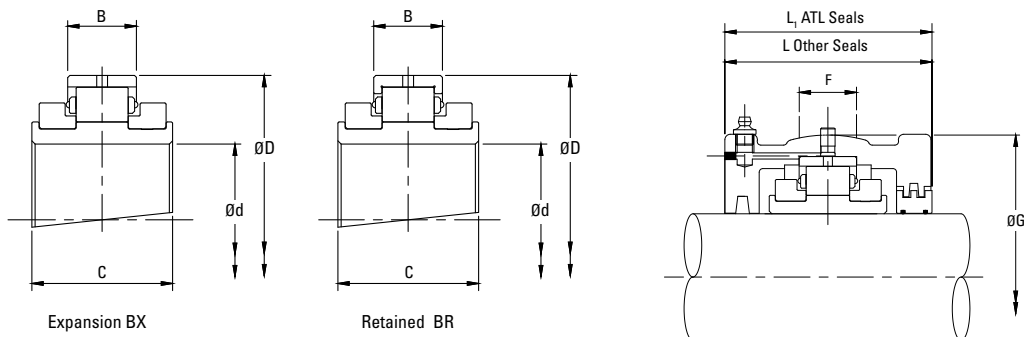

| Shaft (d)         |                                          | Reference                                                    |                                                | Bearings Ratings       |                        |                      |      |                  |                   |                 | Housing Reference                                                         |                                                                               |                                                |                  |           |                |            |
|-------------------|------------------------------------------|--------------------------------------------------------------|------------------------------------------------|------------------------|------------------------|----------------------|------|------------------|-------------------|-----------------|---------------------------------------------------------------------------|-------------------------------------------------------------------------------|------------------------------------------------|------------------|-----------|----------------|------------|
|                   |                                          | Add BR for Retained<br>Add BX for Expansion<br>e.g. LSE215BR |                                                | Dynamic C <sub>r</sub> | Static C <sub>or</sub> | Axial C <sub>a</sub> | Max  | D                | B, B <sub>1</sub> | C               | ATL Seals<br>Add HRTL for Retained Add HXTL for Expansion<br>e.g. LS4HRTL | Other Seal Types<br>Add HR for Retained Add HX for Expansion<br>e.g. LSE215HR | G                                              | F                | L         | L <sub>1</sub> |            |
| mm                | in.                                      |                                                              |                                                | kN lb.                 | kN lb.                 | kN lb.               | RPM  | mm in.           | mm in.            | mm in.          |                                                                           |                                                                               | mm in.                                         | mm in.           | mm in.    | mm in.         |            |
| 160<br>170        | 6 7/16<br>6 1/2                          | LSM160<br>LSM170A                                            | LSE607<br>LSE608                               | 583<br>131064          | 792<br>178049          | 33.00<br>7419        | 1320 | 273.05<br>10.750 | 60.30<br>2.374    | 109.00<br>4.291 | LS11                                                                      | LSM160<br>LSM170A                                                             | LSE607<br>LSE608                               | 311.15<br>12.250 | 76<br>3.0 | 172<br>6.8     | 192<br>7.6 |
| 170<br>175<br>180 | 6 11/16<br>6 3/4<br>6 15/16<br>7         | LSM170<br>LSM175<br>LSM180                                   | LSE611<br>LSE612<br>LSE615<br>LSE700           | 524<br>117800          | 828<br>186142          | 36.40<br>8183        | 1220 | 285.75<br>11.250 | 55.50<br>2.185    | 109.00<br>4.291 | LS12                                                                      | LSM170<br>LSM175<br>LSM180                                                    | LSE611<br>LSE612<br>LSE615<br>LSE700           | 323.85<br>12.750 | 70<br>2.8 | 172<br>6.8     | 200<br>7.9 |
| 190<br>200        | 7 3/16<br>7 1/4<br>7 1/2<br>7 15/16<br>8 | LSM190<br>LSM200                                             | LSE703<br>LSE704<br>LSE708<br>LSE715<br>LSE800 | 614<br>138033          | 990<br>222561          | 41.00<br>9217        | 1070 | 311.15<br>12.250 | 60.30<br>2.374    | 106.00<br>4.173 | LS13                                                                      | LSM190<br>LSM200                                                              | LSE703<br>LSE704<br>LSE708<br>LSE715<br>LSE800 | 358.78<br>14.125 | 86<br>3.4 | 172<br>6.8     | 200<br>7.9 |
| 220<br>230        | 8 7/16<br>8 1/2<br>8 7/8<br>9            | LSM220<br>LSM230                                             | LSE807<br>LSE808<br>LSE814<br>LSE900           | 708<br>159165          | 1168<br>262577         | 49.00<br>11016       | 930  | 342.90<br>13.500 | 63.50<br>2.500    | 115.00<br>4.528 | LS14                                                                      | LSM220<br>LSM230                                                              | LSE807<br>LSE808<br>LSE814<br>LSE900           | 387.35<br>15.250 | 82<br>3.2 | 178<br>7.0     | 216<br>8.5 |
| 240<br>250<br>260 | 9 1/2<br>9 3/4<br>10                     | LSM240<br>LSM250<br>LSM260A                                  | LSE908<br>LSE912<br>LSE1000                    | 744<br>167258          | 1289<br>289779         | 57.80<br>12994       | 820  | 374.65<br>14.750 | 66.70<br>2.626    | 122.00<br>4.803 | LS15                                                                      | LSM240<br>LSM250<br>LSM260A                                                   | LSE908<br>LSE912<br>LSE1000                    | 419.10<br>16.500 | 90<br>3.5 | 188<br>7.4     | 222<br>8.7 |
| 260<br>270<br>280 | 10 7/16<br>10 1/2<br>10 3/4<br>11        | LSM260<br>LSM270<br>LSM280                                   | LSE1007<br>LSE1008<br>LSE1012<br>LSE1100       | 848<br>190638          | 1502<br>337663         | 66.80<br>15017       | 730  | 406.40<br>16.000 | 69.00<br>2.717    | 128.00<br>5.039 | LS16                                                                      | LSM260<br>LSM270<br>LSM280                                                    | LSE1007<br>LSE1008<br>LSE1012<br>LSE1100       | 454.00<br>17.874 | 95<br>3.7 | 204<br>8.0     | 232<br>9.1 |
| 300<br>305        | 11 1/2<br>12                             | LSM300<br>LSM305                                             | LSE1108<br>LSE1200                             | 929<br>208848          | 1665<br>374307         | 78.20<br>17580       | 650  | 438.15<br>17.250 | 74.60<br>2.937    | 143.00<br>5.630 | LS17                                                                      | LSM300<br>LSM305                                                              | LSE1108<br>LSE1200                             | 489.00<br>19.252 | 98<br>3.9 | 216<br>8.5     | 248<br>9.8 |

# LIGHT SN/SD RANGE SUPPORT

## SD11 - SD17

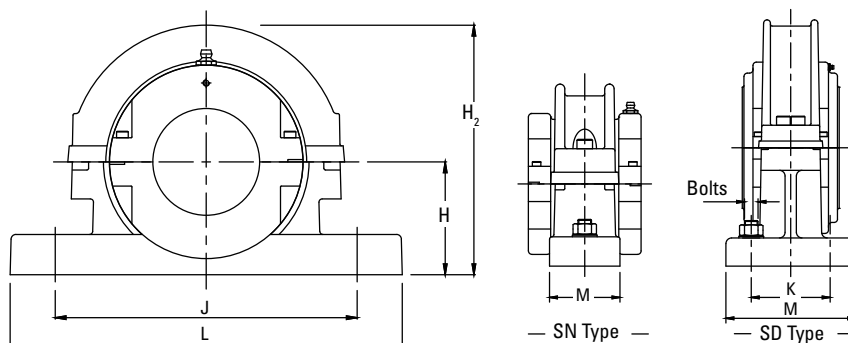

| Shaft (d)         |                                          | Spherical Roller Bearing Reference | SN/SD Reference    | H          | H <sub>2</sub> | J x K                  | L x M                  | Bolts              |
|-------------------|------------------------------------------|------------------------------------|--------------------|------------|----------------|------------------------|------------------------|--------------------|
| mm                | in.                                      |                                    |                    |            |                |                        |                        |                    |
| 160<br>170        | 6 7/16<br>6 1/2                          | SD11                               | SD 3136            | 180        | 396            | 450 x 110              | 530 x 190              | 4 x M24            |
| 170<br>175<br>180 | 6 11/16<br>6 3/4<br>6 15/16<br>7         | SD12<br>SD12A                      | SD 3138<br>SD 3140 | 190<br>210 | 417<br>437     | 480 x 120<br>510 x 130 | 560 x 210<br>610 x 230 | 4 x M24<br>4 x M30 |
| 190<br>200        | 7 3/16<br>7 1/4<br>7 1/2<br>7 15/16<br>8 | SD13                               | SD 3144            | 220        | 457            | 540 x 140              | 640 x 240              | 4 x M30            |
| 220<br>230        | 8 7/16<br>8 1/2<br>8 7/8<br>9            | SD14                               | SD 3148            | 240        | 510            | 600 x 150              | 700 x 260              | 4 x M30            |
| 240<br>250<br>260 | 9 1/2<br>9 3/4<br>10                     | SD15                               | SD 3152            | 260        | 545            | 650 x 160              | 770 x 280              | 4 x M36            |
| 260<br>270<br>280 | 10 7/16<br>10 1/2<br>10 3/4<br>11        | SD16<br>SD16A                      | SD 3156<br>SD 3160 | 280<br>300 | 589<br>609     | 670 x 160<br>710 x 190 | 790 x 280<br>830 x 310 | 4 x M36<br>4 x M36 |
| 300<br>305        | 11 1/2<br>12                             | SD17                               | SD 3164            | 320        | 662            | 750 x 200              | 880 x 330              | 4 x M36            |

# MEDIUM SN/SD RANGE BEARING AND HOUSING

## 135 MM TO 260 MM (5 3/16 IN. TO 10 IN.)

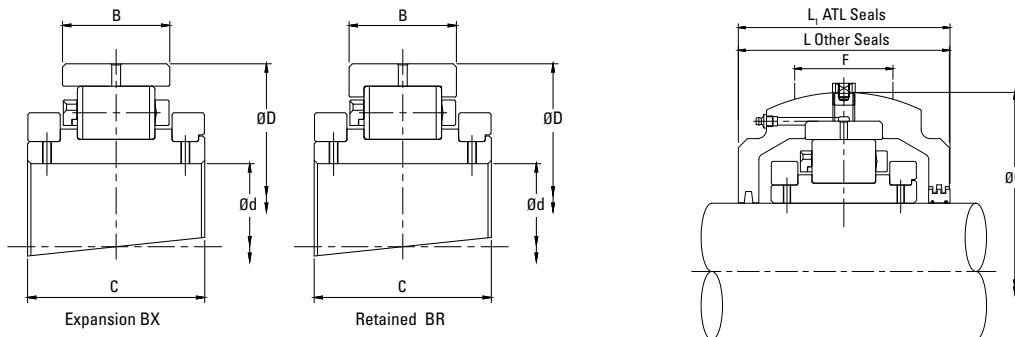

| Shaft (d)                                              |                                                            | Reference                                              |                                                                | Bearings Ratings       |                        |                      |      |        |       |        | Housing Reference |                             |                                                 |        |     |     |     |                |        |        |        |
|--------------------------------------------------------|------------------------------------------------------------|--------------------------------------------------------|----------------------------------------------------------------|------------------------|------------------------|----------------------|------|--------|-------|--------|-------------------|-----------------------------|-------------------------------------------------|--------|-----|-----|-----|----------------|--------|--------|--------|
|                                                        |                                                            |                                                        |                                                                | Dynamic C <sub>r</sub> | Static C <sub>0r</sub> | Axial C <sub>a</sub> | Max  | D      | B     | C      | ATL Seals         |                             | Other Seal Types                                |        | G   | F   | L   | L <sub>1</sub> |        |        |        |
| Add BR for Retained Add BX for Expansion e.g. MSE503BR | Add HRTL for Retained Add HXTL for Expansion e.g. MS30HRTL | Add HR for Retained Add HX for Expansion e.g. MSE503HR | kN lb.                                                         |                        |                        |                      |      |        |       |        | kN lb.            | kN lb.                      | RPM                                             | mm in. |     |     |     |                | mm in. | mm in. | mm in. |
| 135<br>140<br>150                                      | 5 3/16                                                     | MSM135<br>MSM140<br>MSM150A <sup>(1)</sup>             | MSE503<br>MSE504<br>MSE507<br>MSE508<br>MSE600A <sup>(1)</sup> | 600                    | 817                    | 45.40                | 1450 | 273.05 | 66.70 | 117.50 | MS30<br>MS30E0548 | MSM135<br>MSM140<br>MSM150A | MSE503<br>MSE504<br>MSE507<br>MSE508<br>MSE600A | 323.85 | 90  | 186 | 188 |                |        |        |        |
|                                                        | 5 1/4                                                      |                                                        |                                                                |                        |                        |                      |      |        |       |        |                   |                             |                                                 |        |     |     |     | 12.750         | 3.543  | 7.323  | 7.402  |
|                                                        | 5 1/2                                                      |                                                        |                                                                |                        |                        |                      |      |        |       |        |                   |                             |                                                 |        |     |     |     | 10.750         | 2.626  | 4.626  |        |
| 150<br>155<br>160                                      | 5 11/16                                                    | MSM150<br>MSM155<br>MSM160A <sup>(1)</sup>             | MSE511<br>MSE512<br>MSE515<br>MSE600                           | 730                    | 1034                   | 52.40                | 1320 | 292.10 | 68.30 | 123.80 | MS31<br>MS31E0548 | MSM150<br>MSM155<br>MSM160A | MSE511<br>MSE512<br>MSE515<br>MSE600            | 336.55 | 95  | 202 | 204 |                |        |        |        |
|                                                        | 5 3/4                                                      |                                                        |                                                                |                        |                        |                      |      |        |       |        |                   |                             |                                                 |        |     |     |     | 13.250         | 3.74   | 7.953  | 8.031  |
|                                                        | 5 15/16                                                    |                                                        |                                                                |                        |                        |                      |      |        |       |        |                   |                             |                                                 |        |     |     |     | 11.500         | 2.689  | 4.874  |        |
| 160<br>170                                             | 6 7/16                                                     | MSM160<br>MSM170                                       | MSE607<br>MSE608                                               | 842                    | 1175                   | 61.40                | 1200 | 317.50 | 83.30 | 140.00 | MS32              | MSM160<br>MSM170            | MSE607<br>MSE608                                | 368.30 | 95  | 206 | 232 |                |        |        |        |
|                                                        | 6 1/2                                                      |                                                        |                                                                |                        |                        |                      |      |        |       |        |                   |                             |                                                 |        |     |     |     | 14.500         | 3.74   | 8.11   | 9.134  |
| 175<br>180                                             | 6 11/16                                                    | MSM175<br>MSM180                                       | MSE611<br>MSE612<br>MSE615<br>MSE700                           | 927                    | 1357                   | 71.20                | 1120 | 330.20 | 83.30 | 140.00 | MS33              | MSM175<br>MSM180            | MSE611<br>MSE612<br>MSE615<br>MSE700            | 381.00 | 95  | 222 | 242 |                |        |        |        |
|                                                        | 6 3/4                                                      |                                                        |                                                                |                        |                        |                      |      |        |       |        |                   |                             |                                                 |        |     |     |     | 15.000         | 3.74   | 8.74   | 9.528  |
|                                                        | 6 15/16                                                    |                                                        |                                                                |                        |                        |                      |      |        |       |        |                   |                             |                                                 |        |     |     |     | 13.000         | 3.280  | 5.512  |        |
| 190<br>200                                             | 7 1/4                                                      | MSM190<br>MSM200                                       | MSE704<br>MSE708<br>MSE715<br>MSE800                           | 1013                   | 1516                   | 80.00                | 960  | 368.30 | 90.50 | 156.00 | MS34              | MSM190<br>MSM200            | MSE704<br>MSE708<br>MSE715<br>MSE800            | 425.5  | 105 | 235 | 258 |                |        |        |        |
|                                                        | 7 1/2                                                      |                                                        |                                                                |                        |                        |                      |      |        |       |        |                   |                             |                                                 |        |     |     |     | 16.752         | 4.134  | 9.252  | 10.157 |
|                                                        | 7 15/16                                                    |                                                        |                                                                |                        |                        |                      |      |        |       |        |                   |                             |                                                 |        |     |     |     | 14.500         | 3.563  | 6.417  |        |
| 220<br>230                                             | 8 1/2                                                      | MSM220<br>MSM230                                       | MSE807<br>MSE814<br>MSE900                                     | 1138                   | 1668                   | 89.80                | 850  | 393.70 | 90.50 | 163.00 | MS35              | MSM220<br>MSM230            | MSE807<br>MSE814<br>MSE900                      | 457.20 | 110 | 242 | 274 |                |        |        |        |
|                                                        | 8 7/8                                                      |                                                        |                                                                |                        |                        |                      |      |        |       |        |                   |                             |                                                 |        |     |     |     | 18.000         | 4.331  | 9.528  | 10.787 |
|                                                        | 9                                                          |                                                        |                                                                |                        |                        |                      |      |        |       |        |                   |                             |                                                 |        |     |     |     | 15.500         | 3.563  | 6.147  |        |
| 240<br>250<br>260                                      | 9 1/2                                                      | MSM240<br>MSM250<br>MSM260                             | MSE908<br>MSE912<br>MSE1000                                    | 1360                   | 2130                   | 98.80                | 750  | 431.80 | 96.80 | 170.00 | MS36              | MSM240<br>MSM250<br>MSM260  | MSE908<br>MSE912<br>MSE1000                     | 495.30 | 118 | 248 | 280 |                |        |        |        |
|                                                        | 9 3/4                                                      |                                                        |                                                                |                        |                        |                      |      |        |       |        |                   |                             |                                                 |        |     |     |     | 19.500         | 4.646  | 9.764  | 11.024 |
|                                                        | 10                                                         |                                                        |                                                                |                        |                        |                      |      |        |       |        |                   |                             |                                                 |        |     |     |     | 17.000         | 3.811  | 6.693  |        |

<sup>(1)</sup>When ordering these bearings with ATL seals the housing must contain the E0548 suffix.

# MEDIUM SN/SD RANGE SUPPORT

## SN30 - SD36A

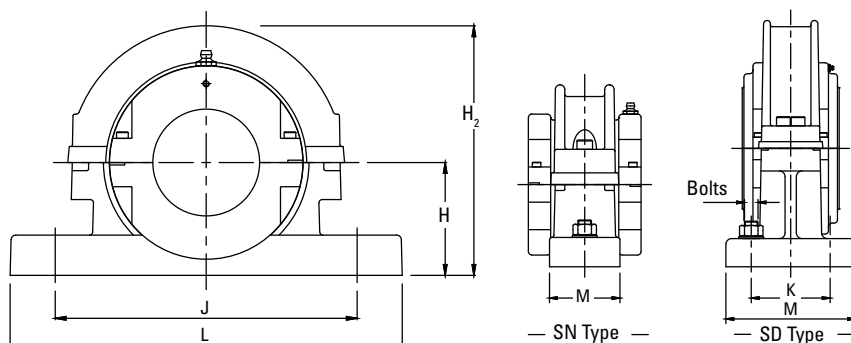

| Shaft (d) |         | Spherical Roller Bearing Reference | SN/SD Reference          | H   | H <sub>2</sub> | J x K     | L x M     | Bolts   |
|-----------|---------|------------------------------------|--------------------------|-----|----------------|-----------|-----------|---------|
| mm        | in.     |                                    |                          |     |                |           |           |         |
| 135       | 5 3/16  | SN30<br>SD30                       | SNL532<br>SD/SNL3134     | 170 | 397            | 470       | 550 x 160 | 2 x M30 |
| 140       | 5 1/4   |                                    |                          | 170 | 397            | 430 x 100 | 510 x 180 | 4 x M24 |
| 150       | 5 7/16  |                                    |                          |     |                |           |           |         |
|           | 5 1/2   |                                    |                          |     |                |           |           |         |
|           | 6       |                                    |                          |     |                |           |           |         |
| 150       | 5 11/16 | SD31                               | SD3136<br>SNL3136        | 180 | 410            | 450 x 110 | 530 x 190 | 4 x M24 |
| 155       | 5 3/4   |                                    |                          |     |                |           |           |         |
| 160       | 5 15/16 |                                    |                          |     |                |           |           |         |
|           | 6       |                                    |                          |     |                |           |           |         |
| 160       | 6 7/16  | SD32                               | SD3138<br>SNL3138        | 190 | 456            | 480 x 120 | 560 x 210 | 4 x M24 |
| 170       | 6 1/2   |                                    |                          |     |                |           |           |         |
| 175       | 6 11/16 | SD33                               | SD3140<br>SNL3140        | 210 | 482            | 510 x 130 | 610 x 230 | 4 x M30 |
| 180       | 6 3/4   |                                    |                          |     |                |           |           |         |
|           | 6 15/16 |                                    |                          |     |                |           |           |         |
|           | 7       |                                    |                          |     |                |           |           |         |
| 190       | 7 1/4   | SD34                               | SD3144<br>SNL3144        | 220 | 510            | 540 x 140 | 640 x 240 | 4 x M30 |
| 200       | 7 1/2   |                                    |                          |     |                |           |           |         |
|           | 7 15/16 |                                    |                          |     |                |           |           |         |
|           | 8       |                                    |                          |     |                |           |           |         |
| 220       | 8 1/2   | SD35                               | SD/SNL3148               | 240 | 566            | 600 x 150 | 700 x 260 | 4 x M30 |
| 230       | 8 7/8   |                                    |                          |     |                |           |           |         |
|           | 9       |                                    |                          |     |                |           |           |         |
| 240       | 9 1/2   | SD36<br>SD36A                      | SD/SNL3152<br>SD/SNL3156 | 260 | 614            | 650 x 160 | 770 x 280 | 4 x M36 |
| 250       | 9 3/4   |                                    |                          |     |                |           |           |         |
| 260       | 10      |                                    |                          |     |                |           |           |         |

## MEDIUM SN/SD RANGE BEARING AND HOUSING 270 MM TO 400 MM (10 ½ IN. TO 16 IN.)

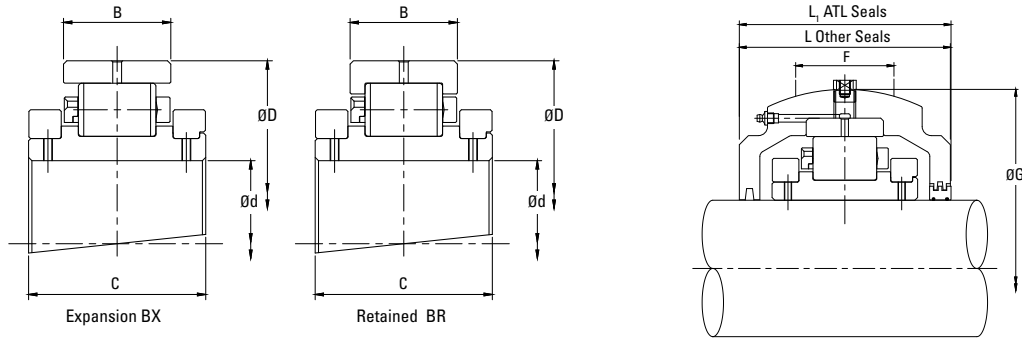

| Shaft (d)                                              |                                                            | Reference                                              |                    | Bearings Ratings       |                        |                      |        |                    |        | Housing Reference |                   |                            |                  |        |        |     |     |
|--------------------------------------------------------|------------------------------------------------------------|--------------------------------------------------------|--------------------|------------------------|------------------------|----------------------|--------|--------------------|--------|-------------------|-------------------|----------------------------|------------------|--------|--------|-----|-----|
|                                                        |                                                            |                                                        |                    | Dynamic C <sub>r</sub> | Static C <sub>or</sub> | Axial C <sub>a</sub> | Max    | D                  | B      | C                 | ATL Seals         |                            | Other Seal Types |        | G      | F   | L   |
| Add BR for Retained Add BX for Expansion e.g. MSE503BR | Add HRTL for Retained Add HXTL for Expansion e.g. MS30HRTL | Add HR for Retained Add HX for Expansion e.g. MSE503HR |                    |                        |                        |                      |        |                    |        |                   |                   |                            |                  |        |        |     |     |
| mm                                                     | in.                                                        |                                                        | kN lb.             | kN lb.                 | kN lb.                 | RPM                  | mm in. | mm in.             | mm in. |                   |                   | mm in.                     | mm in.           | mm in. | mm in. |     |     |
| 270<br>280                                             | 10 ½                                                       | MSM270<br>MSM280                                       | MSE1008            | 1476<br>331818         | 2357<br>529875         | 113.80<br>25583      | 670    | 463.55             | 101.60 | 186.00            | MS37              | MSM270<br>MSM280           | MSE1008          | 527.10 | 130    | 264 | 300 |
|                                                        | 10 ¾<br>11                                                 |                                                        | MSE1012<br>MSE1000 |                        |                        |                      |        | MSE1012<br>MSE1000 | 20.752 | 5.118             |                   |                            | 10.394           |        |        |     |     |
| 300<br>305                                             | 11 ½                                                       | MSM300<br>MSM305                                       | MSE1108            | 1587<br>356771         | 2644<br>594395         | 129.00<br>29000      | 610    | 495.30             | 103.20 | 193.00            | MS38              | MSM300<br>MSM305           | MSE1108          | 552.50 | 128    | 268 | 306 |
|                                                        | 12                                                         |                                                        | MSE1200            |                        |                        |                      |        | MSE1200            | 21.752 | 5.039             |                   |                            | 10.6             |        |        |     |     |
| 320<br>330                                             | 12 ½                                                       | MSM320<br>MSM330                                       | MSE1208            | 1851<br>416121         | 3214<br>722536         | 144.20<br>32417      | 550    | 527.05             | 106.40 | 192.00            | MS39              | MSM320<br>MSM330           | MSE1208          | 587.40 | 128    | 298 | -   |
|                                                        | 13                                                         |                                                        | MSE1300            |                        |                        |                      |        | MSE1300            | 23.126 | 5.039             |                   |                            | 11.732           |        |        |     |     |
| 340<br>350<br>360                                      | 13 ½                                                       | MSM340<br>MSM350<br>MSM360 <sup>(1)</sup>              | MSE1308            | 2029<br>456137         | 3449<br>775366         | 159.20<br>35790      | 500    | 565.15             | 115.90 | 200.00            | MS40<br>MS40E0548 | MSM340<br>MSM350<br>MSM360 | MSE1308          | 628.70 | 146    | 305 | -   |
|                                                        | 14                                                         |                                                        | MSE1400            |                        |                        |                      |        | MSE1400            | 24.752 | 5.748             |                   |                            | 12.008           |        |        |     |     |
| 380                                                    | 15                                                         | MSM380                                                 | MSE1500            | 1931                   | 3522                   | 174.40               | 460    | 584.20             | 111.10 | 200.00            | MS41              | MSM380                     | MSE1500          | 647.70 | 146    | 305 | -   |
|                                                        |                                                            |                                                        |                    | 434106                 | 791777                 | 39207                |        | 23.000             | 4.374  | 7.874             |                   |                            |                  | 25.500 |        |     |     |
| 400                                                    | 16                                                         | MSM400                                                 | MSE1600            | 2105                   | 3793                   | 188.40               | 430    | 615.95             | 115.90 | 200.00            | MS42              | MSM400                     | MSE1600          | 685.80 | 146    | 324 | -   |
|                                                        |                                                            |                                                        |                    | 473223                 | 852700                 | 42354                |        | 24.250             | 4.563  | 7.874             |                   |                            |                  | 27.000 |        |     |     |

<sup>(1)</sup>When ordering these bearings with ATL seals the housing must contain the E0548 suffix.

# MEDIUM SN/SD RANGE SUPPORT

## SD37 - SD42

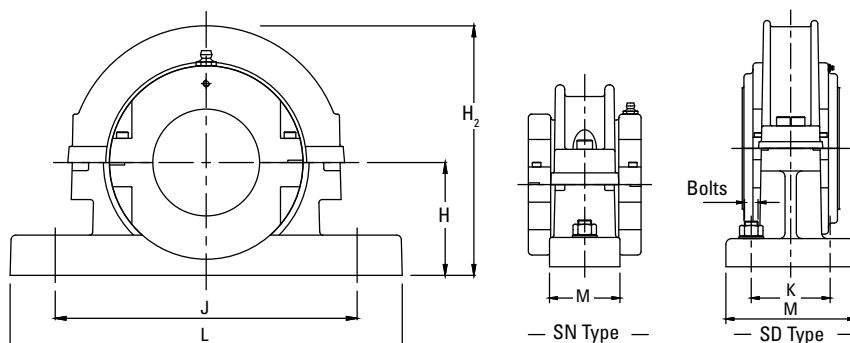

| Shaft (d)         |                    | Spherical Roller Bearing Reference | SN/SD Reference      | H          | H <sub>2</sub> | J x K                  | L x M                    | Bolts              |
|-------------------|--------------------|------------------------------------|----------------------|------------|----------------|------------------------|--------------------------|--------------------|
| mm                | in.                |                                    |                      |            |                |                        |                          |                    |
| 270<br>280        | 10 ½<br>10 ¾<br>11 | SD37                               | SD3160<br>SNL3160    | 300        | 682            | 710 x 190              | 830 x 310                | 4 x M36            |
| 300<br>305        | 11 ½<br>12         | SD38                               | SD3164<br>SNL3164    | 320        | 716            | 750 x 200              | 880 x 330                | 4 x M36            |
| 320<br>330        | 12 ½<br>13         | SD39                               | SNL3168L             | 340        | 761            | 810 x 220              | 950 x 360                | 4 x M36            |
| 340<br>350<br>360 | 13 ½<br>14         | SD40<br>SD40A                      | SNL3172L<br>SNL3176L | 350<br>360 | 799<br>809     | 840 x 220<br>870 x 220 | 1000 x 360<br>1040 x 360 | 4 x M36<br>4 x M36 |
| 380               | 15                 | SD41                               | SNL3180L             | 380        | 841            | 950 x 240              | 1120 x 390               | 4 x M42            |
| 400               | 16                 | SD42                               | SNL3184L             | 410        | 902            | 1000 x 260             | 1170 x 420               | 4 x M42            |













To view more Timken catalogs, go to [www.timken.com/catalogs](http://www.timken.com/catalogs) for interactive versions, or to download a catalog app for your smartphone or mobile device scan the QR code or go to [timkencatalogs.squawqr.com](http://timkencatalogs.squawqr.com).

# TIMKEN

The Timken team applies their know-how to improve the reliability and performance of machinery in diverse markets worldwide. The company designs, makes and markets bearings, gear drives, automated lubrication systems, belts, brakes, clutches, chain, couplings, linear motion products and related industrial motion rebuild and repair services.

**Stronger. By Design.**

[www.timken.com](http://www.timken.com)